

This document and process conversion measures necessary to comply with this change shall be completed by 16 March 2020.

**INCH - POUND**

**MIL-STD-883L  
16 September 2019  
~~SUPERSEDING~~  
MIL-STD-883K  
w/CHANGE 3  
3 May 2018**

**DEPARTMENT OF DEFENSE  
TEST METHOD STANDARD  
MICROCIRCUITS**



AMSC N/A

FSC 5962



DISTRIBUTION STATEMENT A. Approved for public release. Distribution is unlimited.

MIL-STD-883L

FOREWORD

1. This standard is approved for use by all Departments and Agencies of the Department of Defense.
2. This issue of MIL-STD-883 series establishes uniform test methods for testing the environmental, physical, and electrical characteristics semiconductor devices.
3. This entire test method standard has been revised. This revision has been issued in six parts; the basic test method standard (this document) and five numbered parts. This was done in order to provide flexibility in the use and the updating of the test methods. The six parts are listed as follows:
  - MIL-STD-883 – Test Methods For Microcircuits.
  - MIL-STD-883-1 – Environmental Test Methods For Microcircuits.
  - MIL-STD-883-2 – Mechanical Test Methods For Microcircuits.
  - MIL-STD-883-3 – Electrical Test (Digital) Methods For Microcircuits.
  - MIL-STD-883-4 – Electrical Test (Linear) Methods For Microcircuits.
  - MIL-STD-883-5 – Test Procedures For Microcircuits.
4. Comments, suggestions, or questions on this document should be addressed to: Commander, Defense Logistics Agency, DLA Land and Maritime, ATTN: VAC, P.O. Box 3990, Columbus, OH 43218-3990, or emailed to [STD883@dla.mil](mailto:STD883@dla.mil). Since contact information can change, you may want to verify the currency of this address information using the ASSIST Online database at <https://assist.dla.mil>.

## MIL-STD-883L

## CONTENTS

PARAGRAPH	<u>Page</u>
1. SCOPE.....	1
1.1 Purpose.....	1
1.2 Intended use of or reference to MIL-STD-883 .....	1
1.3 Numbering system. ....	2
1.4 Method of reference .....	3
2. APPLICABLE DOCUMENTS .....	4
2.1 General.....	4
2.2 Government documents .....	4
2.3 Non-Government publications .....	5
2.4 Order of precedence.....	7
3. DEFINITIONS.....	8
3.1 Abbreviations, symbols, and definitions.....	8
4. GENERAL REQUIREMENTS .....	10
4.1 Numbering system.....	10
4.2 Test results.....	11
4.3 Test sample disposition .....	11
4.4 Orientation.....	11
4.5 Test conditions .....	14
4.6 General precautions .....	16
4.7 Recycled, recovered, and environmentally preferable materials .....	17
5. DETAIL REQUIREMENTS.....	17
6. NOTES.....	18

## MIL-STD-883L

## TEST METHODS

The following test methods can be found in MIL-STD-883-1.

METHOD NO.	ENVIRONMENTAL TESTS
1001	Barometric pressure, reduced (altitude operation)
1002	Immersion
1003	Insulation resistance
1004.7	Moisture resistance
1005.11	Steady state life
1006	Intermittent life
1007.1	Agree life
1008.2	Stabilization bake
1009.8	Salt atmosphere (corrosion)
1010.9	Temperature cycling
1011.9	Thermal shock
1012.1	Thermal characteristics
1013	Dew point
1014.17	Seal
1015.12	Burn-in test
1016.2	Life/reliability characterization tests
1017.3	Neutron irradiation
1018.10	Internal gas analysis
1019.9	Ionizing radiation (total dose) test procedure
1020.1	Dose rate induced latchup test procedure
1021.3	Dose rate upset testing of digital microcircuits
1022	Mosfet threshold voltage
1023.3	Dose rate response of linear microcircuits
1030.2	Preseal burn-in
1031	Thin film corrosion test
1032.1	Package induced soft error test procedure (due to alpha particles)
1033	Endurance life test
1034.2	Die penetrant test (for plastic devices)

## MIL-STD-883L

## TEST METHODS

The following test methods can be found in MIL-STD-883-2.

METHOD NO.	MECHANICAL TESTS
2001.4	Constant acceleration
2002.5	Mechanical shock
2003.13	Solderability
2004.7	Lead integrity
2005.2	Vibration fatigue
2006.1	Vibration noise
2007.3	Vibration, variable frequency
2008.1	Visual and mechanical
2009.14	External visual
2010.14	Internal visual (monolithic)
2011.10	Bond strength (destructive bond pull test)
2012.11	Radiography
2013.1	Internal visual inspection for DPA
2014	Internal visual and mechanical
2015.14	Resistance to solvents
2016	Physical dimensions
2017.13	Internal visual (hybrid)
2018.6	Scanning electron microscope (SEM) inspection of metallization
2019.10	Die shear strength
2020.9	Particle impact noise detection test
2021.3	Glassivation layer integrity
2022.3	Wetting balance solderability
2023.7	Nondestructive bond pull
2024.2	Lid torque for glass-frit-sealed packages
2025.4	Adhesion of lead finish
2026	Random vibration
2027.2	Substrate attach strength
2028.4	Pin grid package destructive lead pull test
2029.1	Ceramic chip carrier bond strength
2030.2	Ultrasonic inspection of die attach
2031.1	Flip chip pull-off test
2032.3	Visual inspection of passive elements
2035	Ultrasonic inspection of TAB bonds
2036.1	Resistance to soldering heat
2037	X-Ray Fluorescence (XRF) Scan for Tin (Sn)-Lead (Pb) Content Analysis
2038	Solder Column Package Destructive Lead Pull Test

## MIL-STD-883L

## TEST METHODS

The following test methods can be found in MIL-STD-883-3.

METHOD NO.	ELECTRICAL TESTS (DIGITAL)
3001.1	Drive source, dynamic
3002.1	Load conditions
3003.1	Delay measurements
3004.1	Transition time measurements
3005.1	Power supply current
3006.1	High level output voltage
3007.1	Low level output voltage
3008.1	Breakdown voltage, input or output
3009.1	Input current, low level
3010.1	Input current, high level
3011.1	Output short circuit current
3012.1	Terminal capacitance
3013.2	Noise margin measurements for digital microelectronic devices
3014	Functional testing
3015.9	Electrostatic discharge sensitivity classification
3016.1	Activation time verification
3017	Microelectronics package digital signal transmission
3018	Crosstalk measurements for digital microelectronic device packages
3019.2	Ground and power supply impedance measurements for digital microelectronics device packages
3020	High impedance (off-state) low-level output leakage current
3021	High impedance (off-state) high-level output leakage current
3022	Input clamp voltage
3023.2	Static latch-up measurements for digital CMOS microelectronic devices
3024	Simultaneous switching noise measurements for digital microelectronic devices

## MIL-STD-883L

## TEST METHODS

The following test methods can be found in MIL-STD-883-4.

METHOD NO.	ELECTRICAL TESTS (LINEAR)
4001.1	Input offset voltage and current and bias current
4002.1	Phase margin and slew rate measurements
4003.2	Common mode input voltage range Common mode rejection ratio Supply voltage rejection ratio
4004.2	Open loop performance
4005.1	Output performance
4006.2	Power gain and noise figure
4007	Automatic gain control range

The following test methods can be found in MIL-STD-883-5.

	TEST PROCEDURES
5001	Parameter mean value control
5002.1	Parameter distribution control
5003	Failure analysis procedures for microcircuits
5004.13	Screening procedures
5005.17	Qualification and quality conformance procedures
5006	Limit testing
5007.8	Wafer lot acceptance
5008.9	Test procedures for hybrid and multichip microcircuits
5009.1	Destructive physical analysis
5010.4	Test procedures for custom monolithic microcircuits
5011.7	Evaluation and acceptance procedures for polymeric adhesives.
5012.1	Fault coverage measurement for digital microcircuits.
5013.1	Wafer fabrication control and wafer acceptance procedures for processed GaAs wafers

MIL-STD-883L

This page intentionally left blank



## MIL-STD-883L

### 1. SCOPE

1.1 Purpose. This standard establishes uniform methods, controls, and procedures for testing microelectronic devices suitable for use within Military and Aerospace electronic systems including basic environmental tests to determine resistance to deleterious effects of natural elements and conditions surrounding military and space operations; mechanical and electrical tests; workmanship and training procedures; and such other controls and constraints as have been deemed necessary to ensure a uniform level of quality and reliability suitable to the intended applications of those devices. For the purpose of this standard, the term "devices" includes such items as monolithic, multichip, film and hybrid microcircuits, microcircuit arrays, and the elements from which the circuits and arrays are formed. This standard is intended to apply only to microelectronic devices. The test methods, controls, and procedures described herein have been prepared to serve several purposes:

- a. To specify suitable conditions obtainable in the laboratory and at the device level which give test results equivalent to the actual service conditions existing in the field, and to obtain reproducibility of the results of tests. The tests described herein are not to be interpreted as an exact and conclusive representation of actual service operation in any one geographic or outer space location, since it is known that the only true test for operation in a specific application and location is an actual service test under the same conditions.
- b. To describe in one standard all of the test methods of a similar character which now appear in the various joint-services and NASA microelectronic device specifications, so that these methods may be kept uniform and thus result in conservation of equipment, manhours, and testing facilities. In achieving this objective, it is necessary to make each of the general tests adaptable to a broad range of devices.
- c. To provide for a level of uniformity of physical, electrical and environmental testing; manufacturing controls and workmanship; and materials to ensure consistent quality and reliability among all devices screened in accordance with this standard.

1.2 Intended use of or reference to MIL-STD-883. When this document is referenced or used in conjunction with the processing and testing of JAN devices in conformance with the requirements of appendix A of MIL-PRF-38535, QML devices in conformance with MIL-PRF-38535 or non-JAN devices in accordance with 1.2.1 or 1.2.2 herein, such processing and testing is required to be in full conformance with all the applicable general requirements and those of the specifically referenced test methods and procedures.

For contracts negotiated prior to 31 December 1984, device types that have been classified as manufacturer's 883 (B or S) product prior to 31 December 1984 are not required to meet 1.2.1 or 1.2.2.

Existing contracts as of the 31 December 1984, previously negotiated add-ons to these contracts, and future spares for these contracts may continue to use device types which were classified as manufacturer's 883 (B or S) prior to 31 December 1984.

New contracts, and any device types classified as compliant to MIL-STD-883 after 31 December 1984 are required to comply with 1.2.1. Any devices meeting only the provisions of 1.2.2 are noncompliant to MIL-STD-883.

## MIL-STD-883L

**1.2.1 Provisions for the use of MIL-STD-883 in conjunction with compliant non-JAN devices.** When any manufacturer, contractor, subcontractor, or original equipment manufacturer requires or claims a non-JAN part compliant with MIL-STD-883, all provisions of Appendix A of MIL-PRF-38535 are required to be met. In addition, manufacturers that have produced or are producing products in accordance with 1.2.1a are subject to a Government compliance validation audit on a drop-in basis with a minimum of notice. Such processing and testing are required to be in compliance with all of the applicable general controls and requirements defined herein and those of the specifically referenced test methods and procedures with no reinterpretations, deviations or omissions except as specifically allowed in the device specification or standard microcircuit drawing covering the same generic device. Deviations specifically granted in the device specification or standard microcircuit drawing may also be applied to devices manufactured in the same process, to the same design criteria, and using elements of the same microcircuit group as those used for devices covered by the device specification or standard microcircuit drawing. Such reference include the following:

Manufacturers who use MIL-STD-883 in device marking, or make statements in applicable certificates of conformance that parts are compliant with MIL-STD-883, or make statements in advertisements or in published brochures or other marketing documents that parts provided are compliant with MIL-STD-883.

Contractors, sub-contractors, or original equipment manufacturers who prepare vendor item drawings, (previously called Specification Control drawings), or Selected Item drawings which require compliance with MIL-STD-883, or invoke it in its entirety as the applicable standard (see 1.2.2 for noncompliant devices).

- a. Custom monolithic, non-JAN multichip and all other non-JAN microcircuits except non-JAN hybrids described or implied to be compliant with methods 5004 and 5005 or 5010 of MIL-STD-883 are required to meet all of the non-JAN requirements of Appendix A of MIL-PRF-38535.
- b. Hybrid microcircuits described as compliant or multichip microcircuits described as compliant to MIL-PRF-38534 are required to meet all the requirements of MIL-PRF-38534 (or equivalent procedures/ requirements of reciprocal listing provisions for product of other nations based on existing international agreements):

**1.2.2 Provisions for the use of MIL-STD-883 in conjunction with non-compliant non -JAN devices.** Any device that is processed with deviations and which is not processed in compliance with the provisions of 1.2.1 defined herein cannot be claimed to be compliant and cannot be marked "/883", "/883B", "/883S", or any variant thereof. All applicable documentation (including device specifications or manufacturer's data sheets and responses to RFQ's invoking MIL-STD-883) are required to clearly and specifically define any and all areas of nonconformance and identify them as deviations in language that is not subject to misinterpretation by the acquiring authority.

If the contract or order specifically requires compliance with, equivalence to, or a product that is equal to or better than MIL-STD-883 class B or class S, any exceptions taken to the requirements of the referenced quality level (i.e., 1.2.1 above) prohibit the manufacturer from claiming or implying equivalence to that level.

Specific reference to one or more MIL-STD-883 method(s) on a stand-alone basis requires compliance to only the specifically referenced method(s). Such devices are not considered compliant in accordance with 1.2.1 above. However, compliance with only the test procedures contained in test methods 5004, 5005, and 5010 on a stand-alone basis (without specifying compliance or noncompliance to 1.2.1) does not satisfy the requirement for form, fit, and function defined in MIL-PRF-38535 for configuration items, and any reference to these methods on a stand alone basis requires compliance to all the provisions of 1.2.1.

**1.3 Numbering system.** The test methods are designated by numbers assigned in accordance with the following system.

**1.3.1 Classification of tests.** The test methods are divided into five areas and are contained in five parts of this multipart test method standard. Test methods numbered 1000 to 1999 inclusive, cover environmental tests and are in MIL-STD-883-1. Test methods numbered 2000 to 2999 inclusive, cover mechanical- characteristics tests and are in MIL-STD-883-2. Electrical- characteristics tests are covered in two groups; 3000 to 3999 inclusive, cover digital test methods MIL-STD-883-3 and 4000 to 4999 inclusive, cover analog test methods MIL-STD-883-4. Test methods numbered 5000 to 5999 inclusive, are for high reliability space applications and are in MIL-STD-883-5.

MIL-STD-883L

1.3.2 Test method revisions. Test method revisions are numbered consecutively using a period to separate the test method number and the revision number. For example, test method 1001.1 is the first revision of test method 1001.

1.4 Method of reference. Test methods contained in this multipart test method standard should be referenced, when applicable, in the individual specification, specification sheet, or procurement documents by specifying the test method number and the details required in the summary of the applicable method. The basic standard shall be referenced and not the individual part or parts of this standard (see 5.3). To avoid the necessity for changing documents that refer to this standard, the revision number of a test method should not be used when referencing individual test methods. For example, use 1001 as a reference versus 1001.2.

## MIL-STD-883L

## 2. APPLICABLE DOCUMENTS

2.1 General. The documents listed in this section are specified in sections 3, 4, and 5 of this standard. This section does not include documents cited in other sections of this standard or recommended for additional information or as examples. While every effort has been made to ensure the completeness of this list, document users are cautioned that they must meet all specified requirements documents cited in sections 3, 4, and 5 of this standard, whether or not they are listed.

2.2 Government documents.

2.2.1 Specifications, standards, and handbooks. The following specifications, standards, and handbooks form a part of this document to the extent specified herein. Unless otherwise specified, the issues of these documents are those cited in the solicitation or contract.

## DEPARTMENT OF DEFENSE SPECIFICATIONS

- MIL-PRF-680 - Degreasing Solvent, Performance Specification For.
- MIL-PRF-19500 - Semiconductor Devices, General Specification For.
- MIL-PRF-38534 - Hybrid Microcircuits, General Specification For.
- MIL-PRF-38535 - Integrated Circuits (Microcircuits) Manufacturing, General Specification For.

## DEPARTMENT OF DEFENSE STANDARDS

- MIL-STD-202 - Electronic and Electrical Component Parts.
- MIL-STD-750 - Test Methods for Semiconductor Devices.
- MIL-STD-883-1 - Environmental Test Methods for Microcircuits.
- MIL-STD-883-2 - Mechanical Test Methods for Microcircuits.
- MIL-STD-883-3 - Electrical Tests (Digital) Methods for Microcircuits.
- MIL-STD-883-4 - Electrical Tests (Analog) Methods for Microcircuits.
- MIL-STD-883-5 - Test Procedures Microcircuits.
- MIL-STD-1686 - Electrostatic Discharge Control Program for Protection of Electrical and Electronic Parts, Assemblies and Equipment (Excluding Electrically Initiated Explosive Devices).
- MIL-STD-1835 - Electronic Component Case Outlines.
- MIL-STD-1916 - DOD Preferred Methods for Acceptance of Product.

## DEPARTMENT OF DEFENSE HANDBOOKS

- MIL-HDBK-217 - Reliability Prediction of Electronic Equipment.
- MIL-HDBK-505 - Definitions of Item Levels, Item Exchangeability, Models, and Related Terms.
- MIL-HDBK-781 - Reliability Test Methods, Plans, and Environments for Engineering, Development Qualification, and Production .
- MIL-HDBK-1331 - Parameters to be Controlled for the Specification of Microcircuits.

## FEDERAL STANDARDS

- SAE AMS-STD-595 - Colors Used in Government Procurement
- SAE AMS-STD-595/15102 - Blue, Gloss
- SAE AMS-STD-595/25102 - Blue, Semi-gloss

MIL-STD-883L

OTHER GOVERNMENT DOCUMENTS, DRAWINGS, AND PUBLICATIONS

- QML-38534 - Qualified Manufacturers Listing.
- QML-38535 - Qualified Manufacturers Listing.

COMMERCIAL ITEM DESCRIPTIONS

- A-A-58092 - Tape, Antiseize, Polytetrafluorethylene.

(Copies of these documents are available online at <https://quicksearch.dla.mil>.)

2.3 Non-Government publications. The following documents form a part of this document to the extent specified herein. Unless otherwise specified, the issues of these documents are those cited in the solicitation or contract.

INTERNATIONAL ORGANIZATION FOR STANDARDIZATION (ISO) STANDARDS

- ISO 14644-1 - Cleanrooms and Associated Controlled Environments – Part 1: Classification of Air Cleanliness.
- ISO 14644-2 - Cleanrooms and Associated Controlled Environments – Part 2: Specifications for Testing and Monitoring to Prove Continued Compliance with ISO 14644-1.
- ISO /ASTM 51275 - Standard Practice for Use of a Radiochromic Film Dosimetry System.

(Copies of these documents are available online at <https://www.iso.org> or from International Organization for Standardization (ISO), 1, ch. de la Voie-Creuse Case Postale 56, CH-1211 Geneva 20, Switzerland.)

AMERICAN NATIONAL STANDARDS INSTITUTE (ANSI)

- ANSI/NCSL Z540.3 - Requirements for the Calibration of Measuring and Test Equipment, General Requirements.

(Copies of these documents are available online at <https://ansi.org> or from the American National Standards International, 25 West 43<sup>RD</sup> Street, 4<sup>TH</sup> Floor, New York, NY 10036.)

IPC - ASSOCIATION CONNECTING ELECTRONICS INDUSTRIES (IPC)

- IPC J-STD-004 - Requirements for Soldering Fluxes.
- IPC J-STD-005 - Requirements for Soldering Pastes.
- IPC J-STD-006 - Requirements for Electronic Grade Solder Alloys and Fluxed and Non-fluxed Solid Solders for Electronic Soldering Applications.
- IPC J-STD-033 - Handling, Packing, Shipping and Use of Moisture/Reflow Sensitive Surface Mount Devices.
- IPC-T-50 - Terms and Definitions for Interconnecting and Packaging Electronic Circuits.

(Copies of these documents are available online at <http://www.ipc.org> or from the IPC-Association Connecting Electronic Industries, 3000 Lakeside Drive, 105 N, Bannockburn, IL 60015.)

## MIL-STD-883L

## JEDEC SOLID STATE TECHNOLOGY ASSOCIATION (JEDEC).

- JEDEC JESD22-B116 - Wire Bond Shear Test
- JEDEC JESD78 - IC Latch-up Test.
- JEDEC JESD213 - Common Test Method for Detection Component Surface Finish Material.
- JEDEC Standard 12 - Standard for Gate Array Benchmark Set
- JEDEC Standard 12-1 - Terms and Definitions for Gate Array Benchmark Set.
- JEDEC Standard 12-2 - Standard for Cell-Based Integrated Circuit Benchmark Set.
- JEDEC Standard 12-3 - CMOS Gate Array Macrocell Standard.

(Copies of these documents are available online at <https://www.jedec.org> or from JEDEC Solid State Technology Association, 33103 North 10<sup>th</sup> Street, Suite 240 S, Arlington, VA 22201.)

## NATIONAL COUNCIL ON RADIATION PROTECTION AND MEASUREMENT

- Report Number 40 - Protection Against Radiation from Brachytherapy Sources
- Report Number 102 - Medical X-ray, Electron Beam and Gamma Ray Protection

(Copies of these documents are available online at <http://www.NCRPPublications.org> or from National Council on Radiation Protection and Measurement, 7910 Woodmont Avenue, Suite 400, Bethesda, MD 20814-3095.)

## TECHSTREET THOMPSON REUTERS

- TechAmerica EIA-557 - Statistical Process Control Systems.

(Copies of these documents are available online at <https://www.techstreet.com> or from Techstreet Thompson Reuters, 3916 Ranchero Drive, Ann Arbor, MI 48108.)

## AMERICAN SOCIETY FOR TESTING AND MATERIALS (ASTM)

- ASTM C 177 - Standard Test Method for Steady-State Heat Flux Measurements and Thermal Transmission Properties by Means of the Guarded Hot-Plate Apparatus.
- ASTM C 518 - Standard Test Method for Steady-State Heat Flux Measurements and Thermal Transmission Properties by Means of the Heat Flow Meter Apparatus.
- ASTM D 150 - Standard Test Methods for A-C Loss Characteristics and Permittivity (Dielectric Constant) of Solid Electrical Insulating Materials.
- ASTM D 257 - Standard Test Methods for D-C Resistance or Conductance of Insulating Materials.
- ASTM D 877 - Standard Test Methods for Dielectric Breakdown Voltage of Insulating Liquids Using Disk Electrodes.
- ASTM D 971 - Interfacial Tension of Oil Against Water by the Ring Method.
- ASTM D 1002 - Standard Test Method for Strength Properties of Adhesives in Shear by Tension Loading (Metal-to-Metal).
- ASTM D 1120 - Engine Coolant, Boiling Point of.
- ASTM D 1331 - Standard Test Methods for Surface and Interfacial Tension of Solutions of Surface-Active Agents.
- ASTM D 2109 - Standard Test Methods for Nonvolatile Matter in Halogenated Organic Solvents and their Admixtures.
- ASTM D 3574 - Materials, Flexible Cellular-Slab, Bonded, and Molded Uretane Foam.
- ASTM D 3850 - Rapid Thermal Degradation of Solid Electrical Insulating Materials by Thermogravimetric Method, Test Method for.
- ASTM E 263 - Standard Test Method for Measuring Fast-Neutron Reaction Rates by Radioactivation of Iron.
- ASTM E 264 - Standard Test Method for Measuring Fast-Neutron Reaction Rates by Radioactivation of Nickel.

## MIL-STD-883L

## AMERICAN SOCIETY FOR TESTING AND MATERIALS (ASTM) (CONTINUED)

- |             |   |  |
|-------------|---|--|
| ASTM E 265  | - | Standard Test Method for Measuring Reaction Rates and Fast-Neutron Fluences by Radioactivation of Sulfur-32.   |
| ASTM E 666  | - | Standard Practice for Calculating Absorbed Dose from Gamma or X-Radiation.   |
| ASTM E 668  | - | Standard Practice for Application of Thermoluminescence-Dosimetry (TLD) Systems for Determining Absorbed Dose on Radiation Hardness Testing of Electronic Devices.                         |
| ASTM E 720  | - | Standard Guide for Selection and Use of Neutron Sensors for Determining Neutron Spectra Employed in Radiation-Hardness Testing of Electronics.   |
| ASTM E 721  | - | Standard Method for Determining Neutron Energy Spectra with Neutron-Activation Foils for Radiation-Hardness Testing of Electronics.  |
| ASTM E 722  | - | Standard Practice for Characterizing Neutron Energy Fluence Spectra in Terms of an equivalent Monoenergetic Neutron Fluence for Radiation-Hardness Testing of Electronics.                 |
| ASTM E 801  | - | Standard Practice for Controlling Quality of Radiological Examination of Electronic Devices.   |
| ASTM E 831  | - | Standard Test Method for Linear Thermal Expansion of Solid Materials by Thermomechanical Analysis  |
| ASTM E 1249 | - | Minimizing Dosimetry Errors in Radiation Hardness Testing of Silicon Electronic Devices.   |
| ASTM E 1250 | - | Standard Method for Application of Ionization Chambers to Assess the Low Energy Gamma Component of Cobalt 60 Irradiators Used in Radiation Hardness Testing of Silicon Electronic Devices. |
| ASTM E 2450 | - | Standard Practice for Application of CaF <sub>2</sub> (Mn) Thermoluminescence Dosimeters in Mixed Neutron-Photon Environments.   |
| ASTM F 458  | - | Standard Practice for Nondestructive Pull Testing of Wire Bonds.   |
| ASTM F 459  | - | Standard Test Methods for Measuring Pull Strength of Microelectronic Wire Bonds.   |
| ASTM F 526  | - | Standard Test Method for Measuring Dose for Use in Linear Accelerator Pulsed Radiation Effects Tests.  |
| ASTM F 1192 | - | Standard Guide for the Measurement of Single Event Phenomena (SEP).  |
| ASTM F 1892 | - | Standard Guide for Ionizing Radiation (Total Dose) Effects Testing of Semiconductor Devices.   |

(Copies of these documents are available online at <https://www.astm.org/> or from the American Society for Testing and Materials, P O Box C700, 100 Barr Harbor Drive, West Conshohocken, PA 19428-2959.)

(Non-Government standards and other publications are normally available from the organizations that prepare or distribute the documents. These documents also may be available in or through libraries or other informational services.)

2.4 Order of precedence. Unless otherwise noted herein or in the contract, in the event of a conflict between the text of this document and the references cited herein, the text of this document takes precedence. Nothing in this document, however, supersedes applicable laws and regulations unless a specific exemption has been obtained.

## MIL-STD-883L

## 3. DEFINITIONS

3.1 Abbreviations, symbols, and definitions. For the purpose of this standard, the abbreviations, symbols, and definitions specified in MIL-PRF-19500, MIL-PRF-38535, or MIL-HDBK-505 apply. The following definitions also apply:

3.1.1 Microelectronic device. A microcircuit, microcircuit module, or an element of a microcircuit as defined in appendix A of MIL-PRF-38535. For the purposes of this document, each type of microelectronic device will be identified by a unique type, or drawing number.

3.1.2 Mode of failure. The cause for rejection of any failed device or microcircuit as defined in terms of the specific electrical or physical requirement which it failed to meet (i.e., no failure analysis is required to identify the mode of failure, which should be obvious from the rejection criteria of the test method).

3.1.3 Mechanism of failure. The original defect which initiated the microcircuit or device failure or the physical process by which the degradation proceeded to the point of failure, identifying quality defects, internal, structural, or electrical weakness and, where applicable, the nature of externally applied stresses which led to failure.

3.1.4 Absolute maximum ratings. The values specified for ratings, maximum ratings, or absolute maximum ratings are based on the "absolute system" and are not to be exceeded under any measurable or known service or conditions. In testing microelectronic devices, limits may be exceeded in determining device performance or lot quality, provided the test has been determined to be nondestructive and precautions are taken to limit device breakdown and avoid conditions that could cause permanent degradation. These ratings are limiting values beyond which the serviceability of any individual microelectronic integrated circuit may be impaired. It follows that a combination of all the absolute maximum ratings cannot normally be attained simultaneously. Combinations of certain ratings are permissible only if no single maximum rating is exceeded under any service condition. Unless otherwise specified, the voltage, current, and power ratings are based on continuous dc power conditions at free air ambient temperature of  $25^{\circ}\text{C} \pm 3^{\circ}\text{C}$ . For pulsed or other conditions of operation of a similar nature, the current, voltage, and power dissipation ratings are a function of time and duty cycle. In order not to exceed absolute ratings, the equipment designer has the responsibility of determining an average design value, for each rating, below the absolute value of that rating by a safety factor, so that the absolute values will never be exceeded under any usual conditions of supply-voltage variations, load variations, or manufacturing variations in the equipment itself.

The values specified for "Testing Ratings" (methods 1005, 1008, 1015, 5004, and 5005) are intended to apply only to short-term, stress-accelerated storage, burn-in, and life tests and should not be used as basis for equipment design.



## MIL-STD-883L

3.1.5 Worst case condition. Worst case condition(s) consists of the simultaneous application of the most adverse (in terms of required function of the device) values (within the stated operating ranges) of bias(es), signal input(s), loading and environment to the device under test. Worst cases for different parameters may be different. If all the applied test conditions are not established at the most adverse values, the term "partial worst case condition" should be used to differentiate and should be accompanied by identification of the departure from worst case. For example, the lowest values of supply voltages, signal input levels, and ambient temperature and the highest value of loading may constitute "worst case conditions" for measurement of the output voltage of a gate. Use of the most adverse values of applied electrical conditions, at room temperature, would then constitute "partial worst case conditions" and should be so identified using a postscript "at room temperature."

3.1.5.1 Accelerated test condition. Accelerated test conditions are defined as test conditions using one or more applied stress levels which exceed the maximum rated operating or storage stress levels but are less than or equal to the "Testing Rating" values.

3.1.6 Static parameters. Static parameters are defined as dc voltages, dc currents, or ratios of dc voltages or dc currents, or both.

3.1.7 Dynamic parameters. Dynamic parameters are defined as those which are rms or time-varying values of voltages or currents, or ratios of rms or time-varying values of voltages or currents, or both.

3.1.8 Switching parameters. Switching parameters are defined as those which are associated with the transition of the output from one level to another or the response to a step input.

3.1.9 Functional tests. Functional tests are defined as those go, no-go tests which sequentially exercise a function (truth) table or in which the device is operated as part of an external circuit and total circuit operation is tested.

3.1.10 Acquiring activity. The acquiring activity is the organizational element of the Government which contracts for articles, supplies, or services; or it may be a contractor or subcontractor when the organizational element of the Government has given specific written authorization to such contractor or subcontractor to serve as agent of the acquiring activity. A contractor or subcontractor serving as agent of the acquiring activity does not have the authority to grant waivers, deviations, or exceptions unless specific written authorization to do so has also been given by the Government organization.

3.1.11 Accuracy. The quality of freedom from error. Accuracy is determined or assured by calibration, or reliance upon calibrated items.

3.1.12 Calibration. Comparison of measurement standard or instrument of known accuracy with another standard, instrument or device to detect, correlate, report or eliminate by adjustment, any variation in the accuracy of the item being compared. Use of calibrated items provide the basis for value traceability of product technical specifications to national standard values. Calibration is an activity related to measurement and test equipment performed in accordance with ANSI/NCSS Z540.3 or equivalent.

## MIL-STD-883L

3.1.13 Precision. The degree to which an instrument, device, assemblage, test, measurement or process exhibits repeatability. Expressed statistically or through various techniques of Statistical Process Control (SPC). Term is used interchangeably with "repeatability".

3.1.14 Resolution. The smallest unit of readability or indication of known value in an instrument, device or assemblage thereof.

3.1.15 Standard reference material (SRM). A device or artifact recognized and listed by the National Institute of Standards and Technology (NIST) as having known stability and characterization. SRM's used in product testing provide traceability for technical specifications. SRM's do not require calibration when used and stored in accordance with NIST accompanying instructions. They are used as "certified materials".

3.1.16 Tolerance. A documented range over which a specified value may vary.

3.1.17 Test accuracy ratio (TAR). A ratio of the tolerance of the device under test to the accuracy of the related measuring or test instrument or to the accuracy of the correlation device/SRM.

3.1.18 Uncertainty. An expression of the combined errors in a test measurement process. Stated as a range within which the subject quantity is expected to lie. Comprised of many components including: estimates of statistical distribution and results of measurement or engineering analysis. Uncertainty established with a suitable degree of confidence, may be used in assuring or determining product conformance and technical specifications.

3.1.19 Susceptibility. The point at which a device fails to meet the postirradiation end-point electrical parameter limits or fails functionally during radiation exposure (e.g., neutron irradiation).

3.1.20 Class M. Class M is defined as 1.2.1 compliant product or product built in compliance to Appendix A of MIL-PRF-38535 documented on a Standard Microcircuit Drawing where configuration control is provided by the Government preparing activity. Class M devices are required to use the conditions specified in the test methods herein for class level B product.

3.1.21 Class level B and class level S. 2 class levels are used in this document to define requirements for high reliability military applications (Class level B) and space applications (Class level S). Class level B requirements contained in this document are intended for use for Class Q, Class H, and Class M products, as well as Class B M38510 JAN slash sheet product. Class level B requirements are also intended for use for product claimed as 883 compliant or 1.2.1 compliant for high reliability military applications. Class level S requirements contained in this document are intended for use for Class V, Class K, as well as M38510 Class S JAN slash sheet product. Class level S requirements are also intended for use for product claimed as 883 compliant or 1.2.1 compliant for space level applications.

3.1.22 Acquisition documents. Acquisition documents consist of the acquisition order or contract, device specification (e.g. SMD's, SCD's) or specifications as applicable.

#### 4. GENERAL REQUIREMENTS

4.1 Numbering system. The test methods are designated by numbers assigned in accordance with the following system:

4.1.1 Classification of tests. The tests are divided into five classes:

1001 to 1999	Environmental tests
2001 to 2999	Mechanical tests
3001 to 3999	Electrical tests (digital)
4001 to 4999	Electrical tests (analog)
5001 to 5999	Test procedures

## MIL-STD-883L

4.1.2 Revisions. Revisions are numbered consecutively using a period to separate the test method number and the revision number. For example, 4001.1 is the first revision of test method 4001.

4.1.3 Method of reference. When applicable, test methods contained herein shall be referenced in the individual specification by specifying this standard, the method number, and the details required in the summary paragraph of the applicable method. To avoid the necessity for changing specifications which refer to this standard, the revision number should not be used when referencing test methods. For example, use 4001, not 4001.1.

4.2 Test results. The data resulting from application of any test method or procedure shall be reported in terms of the actual test conditions and results. "Equivalent" results (e.g., equivalent 25°C device hours or failure rate derived from 125°C test conditions) may be reported in addition to the actual results but shall not be acceptable as an alternative to actual results. Results of any test method or procedure shall be accompanied by information on the total quantity of devices in each lot being tested on a 100 percent or sampling basis, the associated quantity of devices in the sample for tests on a sampling basis, and the number of failures or devices rejected by test method and observed mode of failure. In cases where more than a single device type (part number) is involved in the makeup of a lot for inspection or delivery, the data shall be reported as above but with a further breakdown by part number.

4.3 Test sample disposition. Test sample disposition shall be in accordance with A.4.3.2.1 of Appendix A of MIL-PRF-38535.

#### 4.4 Orientation.

4.4.1 Identification of orientation and direction of forces applied. For those test methods which involve observation or the application of external forces which must be related to the orientation of the device, such orientation and direction of forces applied shall be identified in accordance with figures 1 and 2.

4.4.2 Orientation for other case configurations. For case configurations other than those shown in figures 1 and 2, the orientation of the device shall be as specified in the applicable acquisition document.

4.4.3 Orientation for packages with different size lateral dimensions. In flat packages where radial leads emanate from three or more sides, the X-direction shall be assigned to the larger and the Z-direction to the smaller of the two lateral dimensions.

MIL-STD-883L

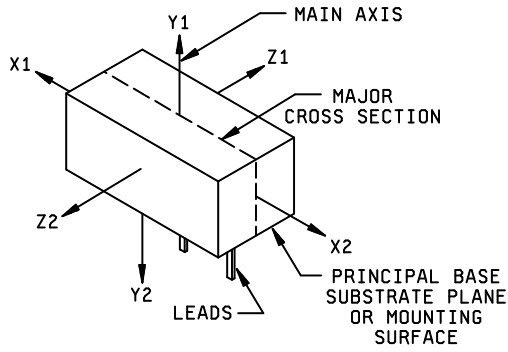

FIGURE 1a. Orientation of microelectronic device to direction of applied force.

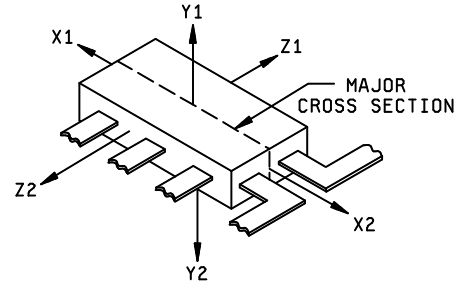

FIGURE 1b. Radial lead flat packages.

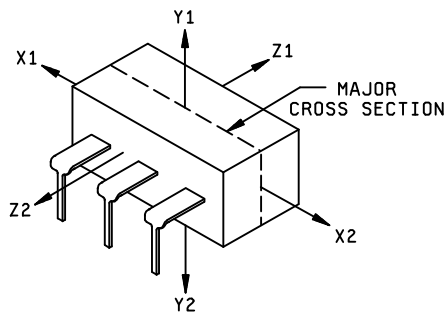

FIGURE 1c. Dual-in-line package.

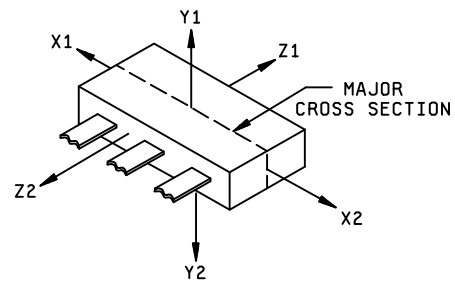
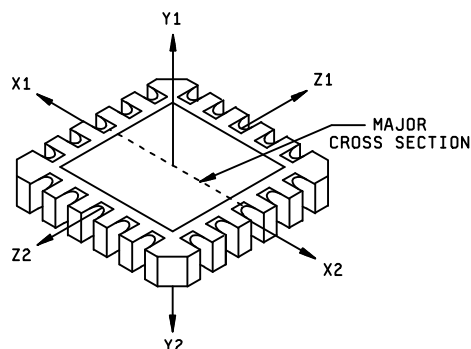

FIGURE 1d. Flat package with radial leads from one side only.

FIGURE 1. Orientation noncylindrical microelectronic devices to direction of applied forces.

## MIL-STD-883L

FIGURE 1e. Leadless chip carrier (top view).

NOTE: The Y1 force application is such that it will tend to lift the die off the substrate or the wires off the die. The reference to applied force actually refers to the force which operates on the device itself and may be the resultant of the primary forces applied in a different manner or direction to achieve the desired stress at the device (e.g., constant acceleration).

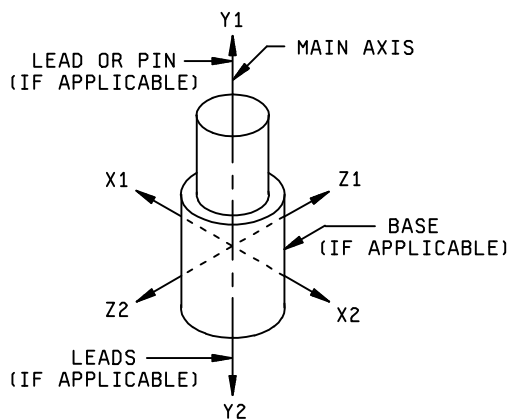
FIGURE 1. Orientation of noncylindrical microelectronic devices to direction of applied forces - Continued.

NOTE: The Y1 force application is such that it will tend to lift the die off the substrate or the wires off the die. The reference to applied force actually refers to the force which operates on the device itself and may be the resultant of the primary forces applied in a different manner or direction to achieve the desired stress at the device (e.g., constant acceleration).

FIGURE 2. Orientation of cylindrical microelectronic device to direction of applied forces.

## MIL-STD-883L

4.5 Test conditions. All newly designed device types shall meet the test conditions specified in 4.5.1 through 4.5.3.2.

4.5.1 Calibration requirements. Calibration shall be applied to those items of measuring and test equipment used to assure product delivery specifications or critical manufacturing elements. Calibration shall be performed in accordance with the requirements of ANSI/NCSL Z540.3 or equivalent. Calibrated items shall be controlled, used and stored in a manner suitable to protect calibration integrity. Test equipment requiring calibration (single items or assemblages) shall be identified and labeled in accordance with ANSI/NCSL Z540.3 or equivalent.

4.5.2 Electrical test equipment accuracy. Unless otherwise specified in the acquisition document, test conditions such as: voltage, resistive loads, capacitive loads, input switching parameters, input static parameters, currents and others shall be set to nominal values as defined in the acquisition document, with tolerances suitable for the test in which they are used.

4.5.3 Electrical test equipment capability. Using any or all of the following techniques, the manufacturer shall determine that the test set/system is suitable to ensure product conformance with the acquisition document. Alternate suitable techniques may be used when approved by the qualifying activity. The manufacturer shall define and document methods used. The test equipment accuracy should be better than the allowable device tolerance in accordance with the following ratios:

- a. Greater than or equal to 10:1 for routine processes.
- b. Greater than or equal to 4:1 for special processes (commercial equipment not readily available).

NOTE: State of the art requirements in which 4:1 can not be effectively achieved due to a lack of national standards shall be justified and documented.

4.5.3.1 Control based on uncertainty. Test processes that have complex characteristics are best performed and controlled by the application of uncertainty analysis. The overall uncertainty in a test or measurement process shall be determined and the impact of said uncertainty on the product parameter tolerance shall be taken into account. The methods used for determining uncertainty shall be defined and documented. The method selected may use any (or combinations) of the following forms:

- a. Arithmetic addition (linear), normally produces an overly conservative estimate and reflects a highly improbable situation in which contributing errors are at their maximum limit at the same time and same direction.
- b. Root Sum Square (RSS), normally applied where the errors tend to fit a normal distribution (gaussian) and are from independent sources.
- c. Partial Derivatives, used where complex relationships exist.
- d. Monte Carlo Simulation, used in very complex situations where other methods are not easily applied or do not fit.
- e. SRM (or controlled correlation device) testing providing observable data.

NOTE: Observable data, from a controlled device, may be relied upon to provide feedback that confirms process performance is within statistical limits.

- f. Analysis of systematic and random errors, applying corrections as applicable.
- g. Any other recognized method of combining errors into an expression of uncertainty substantiated by an engineering analysis.

## MIL-STD-883L

4.5.3.2 Use and control of correlation devices/SRM's. When a manufacturer elects to use correlation devices or SRM's, methods of use and control shall be in place and documented including parameters, type, quantity, description, identification, storage, handling and periodic verification requirements.

4.5.4 Electrical test frequency. Unless otherwise specified, the electrical test frequency shall be the specified operating frequency. Where a frequency range is specified, major functional parameters shall be tested at the maximum and minimum frequencies of the range in addition to those tests conducted at any specified frequency within the range. Whenever electrical tests are conducted on microelectronic devices for which a range of frequencies or more than a single operating frequency is specified, the frequency at which tests are conducted shall be recorded along with the parameters measured at those frequencies.

4.5.5 Testing of multiple input/output devices. Where any input or output parameter is specified for devices having more than a single input or output, the specified parameter shall be tested at all input or output terminations of the device.

4.5.6 Testing of complex devices. Where microelectronic devices being tested contain multiple circuits or functions, whether independently connected to the external device leads or whether internally connected in some arrangement to minimize the number of external leads, suitable test circuits and procedures shall be applied so as to test all circuits or functions contained in the device with all the applicable test methods specified in the applicable acquisition document. For example, if a device contains a pair of logic gates it shall not be acceptable to test only one of the gates for the specified parameters. Furthermore, multiple circuit devices should be tested to assure that no significant interaction exists between individual circuits (e.g., application of signal to one gate of a dual gate device should not cause a change in output of the other gate). The intent of this requirement is to assure that all circuit elements in a microelectronic device are exercised to the fullest extent allowed by their construction and connection provisions. For circuit arrays containing complex signal paths which vary depending on the nature of incoming signals or internal functions performed on the incoming signals, this requirement shall be met by programming the operation of the device to assure that all circuit elements are caused to function and thus provide the opportunity to observe or measure the levels of their performance in accordance with the specified test methods.

4.5.7 Test environment. Unless otherwise specified herein, or in the applicable acquisition documentation, all measurements and tests shall be made at ambient temperature of 25°C +3°C, -5°C and at ambient atmospheric pressure from 580 to 800 millimeters mercury.

4.5.8 Permissible temperature variation in environmental chambers. When chambers are used, specimens under test shall be located only within the working area defined as follows:

- a. Temperature variation within working area: The controls for the chamber shall be capable of maintaining the temperature of any single reference point within the working area within  $\pm 2^{\circ}\text{C}$  or  $\pm 4$  percent, whichever is greater.
- b. Space variation within working area: Chambers shall be so constructed that at any given time, the temperature of any point within the working area shall not deviate more than  $\pm 3^{\circ}\text{C}$  or  $\pm 3$  percent, whichever is greater, from the reference point, except for the immediate vicinity of specimens generating heat.
- c. Chambers with specified minimum temperatures (e.g., burn-in, life test, etc.): When test requirements involve a specified minimum test temperature, the controls and chamber construction shall be such that the temperature of any point within the working area shall not deviate more than  $+8^{\circ}\text{C}$ ,  $-0^{\circ}\text{C}$ ; or  $+8$ ,  $-0$  percent, whichever is greater, from the specified minimum temperature.

4.5.9 Control of test temperature during electrical measurements. Unless otherwise specified, the specified test temperature, case ( $T_C$ ), ambient ( $T_A$ ), or junction ( $T_J$ ) shall be controlled by the applicable procedure(s) specified herein. These are exclusively for the control of chambers, handlers, etc., used in electrical measurements of devices at specified temperatures and the provisions of 4.5.8 do not apply. Testing shall be conducted using either power-off condition followed by low duty cycle pulse testing or power stable temperature condition.

## MIL-STD-883L

4.5.9.1 Temperature control during testing for  $T_C$ ,  $T_A$ , or  $T_J$  above 25°C. Unless otherwise specified, the device (including its internal elements; e.g., die, capacitors, resistors, etc.) shall reach temperature and be stabilized in the power-off condition to within  $\pm 3$  °C (or  $+6$  °C  $-3$  °C for hybrids) of the specified temperature. Note: Hybrids may exceed the positive tolerance of  $+6$  °C if their construction dictates and providing the manufacturer can assure that the devices under test are not degraded. When an established temperature characterization profile is available for a device to be tested, this profile may be used in lieu of temperature measurements to determine the proper heat soak conditions for meeting this requirement. When using a temperature characterization profile, test apparatus monitoring will assure that the controls are providing the proper test environment for that profile. After stabilization, testing shall be performed and the  $T_C$ ,  $T_A$ , or  $T_J$  controlled to not fall more than 3 °C from the specified temperature. The temperature during test may exceed 3 °C of the specified  $T_C$ ,  $T_A$ , or  $T_J$  provided the manufacturer assures that the devices under test are not being degraded. The electrical test parameters shall be measured using low duty cycle pulse testing or, if specified, power stable conditions (see 4.5.9.4).

4.5.9.2 Temperature control during testing for  $T_C$ ,  $T_A$ , or  $T_J$  below 25°C. Unless otherwise specified, the device (including its internal elements; e.g., die, capacitors, resistors, etc.) shall reach temperature and be stabilized in the power-off condition to within  $\pm 3$  °C (or  $-6$   $+3$  °C for hybrids) of the specified temperature (see note below). Note: Hybrids may exceed the negative tolerance of  $-6$  °C if their construction dictates and providing the manufacturer can assure that the devices under test are not degraded. When an established temperature characterization profile is available for a device to be tested, this profile may be used in lieu of temperature measurements to determine the proper heat soak conditions for meeting this requirement. When using a temperature characterization profile, test apparatus monitoring will assure that the controls are providing the proper test environment for that profile. After stabilization, (this temperature shall be identified as the cold-start temperature) testing shall be performed and the  $T_C$ ,  $T_A$ , or  $T_J$  controlled to not exceed  $+5$  °C of the specified temperature throughout the test duration. The electrical test parameters shall be measured using low duty cycle pulse testing or, if specified, power stable conditions (see 4.5.9.4). When applicable, the detail specification shall specify those parameters or sequence of tests most sensitive to the cold-start temperature. These parameters, when specified, shall be measured at the start of the test sequence and shall be completed as soon as possible or within a specified time.

NOTE: Unless otherwise specified in the applicable detail specification, the set temperature shall be  $-55$ °C ( $T_C$ ,  $T_A$ , or  $T_J$ , as applicable) or colder if the device temperature ( $T_C$ ,  $T_A$ , or  $T_J$ , as applicable) increases by more than  $+5$ °C during the test duration.

4.5.9.3 Temperature control during testing for  $T_C$ ,  $T_A$ , or  $T_J$  at 25°C. Unless otherwise specified, the device (including its internal elements; e.g., die, capacitors, resistors, etc.) shall be stabilized in the power-off condition until the temperature is  $25$ °C  $+3$ °C,  $-5$ °C. The electrical test parameters shall be measured using low duty pulse testing or, if specified, power stable conditions (see 4.5.9.4).

4.5.9.4 Power stable temperature condition. When specified, the device shall be stabilized in the specified steady-state power-on condition at the specified test temperature,  $T_A$ ,  $T_C$ , or  $T_J$  as applicable, for temperatures at, above, or below 25°C for a minimum time period of 5 minutes or a specified time. The electrical parameters measurements shall be completed as soon as possible or within a specified period of time after temperature/power stabilization has occurred. Alternatively, when specified, the device temperature  $T_C$  or  $T_A$  may be stabilized within  $\pm 3$ °C of the junction temperature typically predicted for the specified steady-state power-on condition of 5 minutes or more and the testing conducted with low duty pulse techniques.

4.6 General precautions. The following precautions shall be observed in the testing of devices:

4.6.1 Transients. Devices shall not be subjected to conditions in which voltage or current transients cause the ratings to be exceeded.

4.6.2 Order of connection of leads. Care should be taken when connecting a microelectronic device to a power source. For MOS devices or other microelectronic circuits or devices where the order of connection of leads may be important, precautions cited in the applicable acquisition document shall be observed.



## MIL-STD-883L

4.6.3 Soldering and welding. Adequate precautions shall be taken to avoid damage to the device during soldering or welding required for tests.

4.6.4 Radiation precautions. Due precautions shall be used in storing or testing microelectronic devices in substantial fields of x-rays, neutrons, or other energy particles.

4.6.5 Handling precautions for microelectronic devices.

- a. Ground all equipment prior to insertion of the device for electrical test.
- b. Where applicable, keep devices in metal shields until they are inserted in the equipment or until necessary to remove for test.
- c. Where applicable, keep devices in carriers or other protective packages during test.

4.7 Recycled, recovered, environmentally preferable, or biobased materials. Recycled, recovered, environmentally preferable, or biobased materials should be used to the maximum extent possible, provided that the material meets or exceeds the operational and maintenance requirements, and promotes economically advantageous life cycle costs.

## 5. DETAILED REQUIREMENTS

5.1 Organization. This standard is comprised of six different parts, each of which is a separate publication with a unique identification number. This type of organization provides flexibility in referencing, and revising the test methods of the different parts of this standard. The complete standard consists of the basic standard and the five numbered parts.

5.2 Arrangement and contents. Each numbered part of this standard contains a series of test methods. Test methods covering similar tests are grouped together for ease of useability and referencing as follows:

a. Part 1 is identified as MIL-STD-883-1. This part contains all of the environmental test methods. These test methods are numbered 1001 Through 1034.

b. Part 2 is identified as MIL-STD-883-2. This part contains all of the mechanical test methods. These test methods are numbered 2001 through 2038.

c. Part 3 is identified as MIL-STD-883-3. This part contains electrical test methods (Digital). These test methods are numbered 3001 through 3024.

d. Part 4 is identified as MIL-STD-883-4. This part contains electrical test methods (Analog). These test methods are numbered 4001 through 4007.

e. Part 5 is identified as MIL-STD-883-5. This part contains the high reliability space application test methods. These test methods are numbered 5001 through 5013

5.3 References to MIL-STD-883. All the requirements of this standard, its five associated parts, and the individual test methods in those parts are interchangeable with those standards identified as MIL-STD-883. Therefore, existing specifications, specification sheets or OEM documents referencing MIL-STD-883 do not need to be revised, updated, or changed to make reference to any of the different parts of this revision of MIL-STD-883.

## MIL-STD-883L

## 6. NOTES

(This section contains information of a general or explanatory nature that may be helpful, but is not mandatory.)

6.1 Intended use. The intended use of this standard is to establish appropriate conditions for testing microcircuit devices to give test results that simulate the actual service conditions existing in the field. This standard has been prepared to provide uniform methods, controls, and procedures for determining with predictability the suitability of such devices within Military, Aerospace and special application equipment. This standard is applicable only to microelectronic devices, i.e. monolithic, multi-chip, film and hybrid microcircuits, microcircuit arrays, and the elements from which the circuits and arrays are formed.

6.2 Chemical listing. The following is a listing of chemicals identified for use in MIL-STD-883 test methods:

<u>Material</u>	<u>CAS listing</u>	<u>Test method</u>
Acetic Acid	64-19-7	2021
3,5-Dimethyl-1-hexyn-3-ol	4209-91-0	1002
Ethylbenzene	100-41-4	2015
Fluorescein	2321-07-5	1014
Freon-113 <sup>1/</sup>	76-13-1	2015,1014
Hydrochloric Acid	7647-01-0	1009
Isopropyl Alcohol	67-63-0	2015,2003
Kerosene	8008-20-6	2015
Morpholine	110-91-8	1002
Methanol	67-56-1	1002
Methylene Chloride <sup>1/</sup>	75-09-2	2015
Mineral Spirits	8032-32-4	2015
Monoethanolamine	141-43-5	2015
Nitric Acid	7697-37-2	2021
Phosphoric Acid	7664-38-2	2021
Propylene Glycol Monomethyl Ether	107-98-2	2015
Rhodamine B	81-88-9	1014
Sodium Chloride	7647-14-5	1009,1002
Sodium Hydroxide	1310-73-2	1009
Stannous Chloride	7772-99-8	1002
1,1,1-Trichloroethane <sup>1/</sup>	71-55-6	2015
Zyglon Dye	8002-05-9	1014

In the event of a chemical emergency (example: spill, leak, fire, or exposure) obtain additional help or information by calling the telephone number listed below and identify the chemical by the CAS number provided above.

Chem Trec: 1-800-424-9300

6.3 Subject term (key word) listing.

- Abbreviations
- Chemical listing
- Classification of tests
- Electrical test equipment accuracy
- General precautions
- Intended use
- Orientation
- Provisions for the use of MIL-STD-883
- Test environment

<sup>1/</sup> These chemicals are no longer required to be used in MIL-STD-883 test methods.

MIL-STD-883L

6.4 Change notations. The margins of this standard are marked with asterisks to indicate modifications generated by this change. This was done as a convenience only and the Government assumes no liability whatsoever for any inaccuracies in these notations. Bidders and contractors are cautioned to evaluate the requirements of this document based on the entire content irrespective of the marginal notations.

MIL-STD-883L

CONCLUDING MATERIAL

Custodians:  
Army - CR  
Navy - EC  
Air Force – 85  
NASA – NA  
DLA – CC

Preparing activity:  
DLA – CC

(Project 5962-2019-004)

Review activities:  
Army - AR, EA, MI, SM  
Navy – AS, CG, MC, SH  
Air Force – 03, 19

NOTE: The activities listed above were interested in this document as of the date of this document. Since organizations and responsibilities can change, you should verify the currency of the information above using the ASSIST Online database at <https://assist.dla.mil>.