

**MIL-STD-756B**

**18 NOVEMBER 1981**

**SUPERSEDING  
MIL-STD-756A  
15 MAY 1963**

# **MILITARY STANDARD**

**RELIABILITY MODELING AND PREDICTION**



**AMSC N3125**

**FSC RELI**

MIL-STD-756B

DEPARTMENT OF DEFENSE  
Washington, DC 20301

RELIABILITY MODELING AND PREDICTION

MIL-STD-756B

1. This Military Standard is approved for use by all Departments and Agencies of the Department of Defense.
2. Beneficial comments (recommendations, additions, deletions) and any pertinent data which may be of use in improving this document should be addressed to: Commanding Officer, Engineering Specifications and Standards Department (Code 93), Naval Air Engineering Center, Lakehurst, New Jersey 08733, by using the self-addressed Standardization Document Improvement Proposal (DD Form 1426) appearing at the end of this document or by letter.

## MIL-STD-756B

## FOREWORD

Reliability prediction is an essential function in evaluating a design from concept through development and in controlling changes during production. Prediction provides a rational basis for design decisions such as the choice between alternative concepts, choice of part quality levels, derating to be applied, use of proven versus state-of-the-art techniques, and other factors.

It is essential that common ground rules be established for techniques and data sources used in the formulation of reliability models and predictions so that they may be applied and interpreted uniformly. This standard establishes procedures and ground rules intended to achieve this purpose.

It must be recognized that reliability prediction is a best estimate of the reliability anticipated from a given design within data limitations and the extent of item definition. A properly performed reliability prediction is invaluable to those responsible for making program decisions regarding the feasibility and adequacy of a design approach.

Reliability predictions are generally based on experience data from similar items, or their components, used in a same or similar manner. Extreme caution must be exercised in ascertaining the similarity of other items and the degree of similarity in the conditions of use. This standard emphasizes verification and justification of the validity and applicability of data sources to the preparation of predictions.

The necessity for determining the costs of achieving and sustaining the reliability of an item requires that reliability be considered from two perspectives, reliability as a measure of operational effectiveness (Mission Reliability) and reliability as a measure of ownership cost (Basic Reliability). The incorporation of redundancies and alternate modes of operation to improve Mission Reliability invariably decreases Basic Reliability and increases procurement and logistic support costs. This standard addresses Mission Reliability prediction and Basic Reliability prediction as separate but companion predictions both of which are essential to adequately quantify the reliability of an item.

The need for updating a given prediction will vary from program to program and cannot be precisely established in a general standard. Updating will depend primarily on the degree to which the item has been defined, and the availability of pertinent data. Provisions should be made for reliability prediction updates at all design review points and other major program milestones.

## MIL-STD-756B

## CONTENTS

Paragraph		Page
1.	SCOPE . . . . .	1
1.1	Scope . . . . .	1
1.2	Application . . . . .	1
1.3	Purpose . . . . .	1
1.4	Numbering system . . . . .	1
1.4.1	Classification of task sections, tasks and methods . . . . .	1
1.5	Revisions . . . . .	2
1.5.1	Standard . . . . .	2
1.5.2	Task sections, tasks, and methods . . . . .	2
1.6	Method of reference . . . . .	2
2.	REFERENCED DOCUMENTS . . . . .	2
2.1	Issues of documents . . . . .	2
2.2	Other publications . . . . .	3
3.	DEFINITIONS . . . . .	4
3.1	Terms . . . . .	4
4.	GENERAL REQUIREMENTS . . . . .	4
4.1	General . . . . .	4
4.2	Implementation . . . . .	4
4.3	Ground rules and assumptions . . . . .	5
4.4	Indenture level . . . . .	5
4.5	Coding system . . . . .	5
4.6	Mission success definition . . . . .	5
4.7	Coordination of effort . . . . .	5
4.8	General procedures . . . . .	5
4.8.1	Item definition . . . . .	6
4.8.2	Service use profile . . . . .	6
4.8.2.1	Logistic cycle . . . . .	7
4.8.2.2	Operational cycle . . . . .	7
4.8.2.2.1	Mission profile . . . . .	7
4.8.2.3	Environmental profile . . . . .	7
4.9	Reliability modeling and prediction report . . . . .	7
4.9.1	Summary . . . . .	7
4.9.2	Reliability critical element lists . . . . .	9
5.	DETAILED REQUIREMENTS . . . . .	9
5.1	Task description and methods . . . . .	9
5.1.1	Details to be specified . . . . .	9

## CONTENTS (Continued)

Page

FIGURES

Figure 1.	Service use events in the logistic and operational cycles . . . . .	8
Figure 102.1	Performance parameters, limits and failure criteria . . . . .	102-3
Figure 2003.1	Failure-rate estimating chart for electronic analog function . . . . .	2003-3
Figure 2003.2	Failure-rate estimation chart for digital electronics functions . . . . .	2003-5
Figure 2003.3	Failure-rate estimation chart for mechanical devices . . . . .	2003-7

TASK SECTIONS

Task		
Section 100	Reliability modeling . . . . .	100-1
200	Reliability prediction . . . . .	200-1

TASKS

Task 101	Basic reliability model . . . . .	101-1
102	Mission reliability model . . . . .	102-1
201	Basic reliability prediction . . . . .	201-1
202	Mission reliability prediction . . . . .	202-1

METHODS

Method 1001	Conventional probability . . . . .	1001-1
1002	Boolean truth table . . . . .	1002-1
1003	Logic diagram . . . . .	1003-1
1004	Monte carlo simulation . . . . .	1004-1
2001	Similar item method . . . . .	2001-1
2002	Similar circuit method . . . . .	2002-1
2003	Active element group method . . . . .	2003-1
2004	Parts count method . . . . .	2004-1
2005	Parts stress analysis method . . . . .	2005-1

## CONTENTS (Continued)

APPENDIX A. APPLICATION AND TAILORING GUIDE

Paragraph		
10.	GENERAL . . . . .	A-1
10.1	Scope . . . . .	A-1
10.2	Tailoring requirements . . . . .	A-1
10.3	Duplication of effort . . . . .	A-1
10.4	Limitations . . . . .	A-1
20.	REFERENCED DOCUMENTS . . . . .	A-1
30.	DEFINITIONS . . . . .	A-1
40.	GENERAL . . . . .	A-2
40.1	Ordering data . . . . .	A-2
40.2	Data item descriptions . . . . .	A-2
50.	APPLICATION CRITERIA . . . . .	A-2
50.1	General considerations . . . . .	A-2
50.1.1	Level of detail . . . . .	A-2
50.1.2	Timing . . . . .	A-2
50.1.3	Intended use . . . . .	A-3

## 1. SCOPE

1.1 Scope. This standard establishes uniform procedures and ground rules for the preparation of Mission Reliability and Basic Reliability models and predictions for electronic, electrical, electro-mechanical, mechanical, and ordnance systems and equipments, hereinafter referred to as items. Item complexity may range from a complete weapon system to the simplest subdivision of a system. The primary value of Reliability Prediction is as a design tool to provide relative measures of item reliability to design decisions. Great caution must be used when applying and translating the absolute value of the Reliability Prediction to measures of Field Reliability.

1.2 Application. The requirements and procedures established by this standard may be applied to any Department of Defense procurement for item development and production. It is not intended that all the requirements herein will need to be applied to every program or program phase. Procuring activities shall tailor the requirements of this standard to the minimum needs of each procurement and shall encourage contractors to submit cost effective tailoring recommendations.

1.3 Purpose. Reliability modeling and prediction is a methodology for estimating an item's ability to meet specified reliability requirements. A Mission Reliability prediction estimates the probability that an item will perform its required functions during the mission. A Basic Reliability prediction estimates the demand for maintenance and logistic support caused by an item's unreliability. When used in combination, the two predictions provide a basis for identifying areas wherein special emphasis or attention is needed, and for comparing the ownership cost-effectiveness of various design configurations. The two predictions may also be used as a basis for the apportionment (allocation) of ownership cost and operational effectiveness requirements to various subdivisions.

1.4 Numbering system. Task sections, tasks, and methods are numbered sequentially as they are introduced into this standard in accordance with the following classification system.

### 1.4.1 Classification of task sections, tasks, and methods.

100	- Reliability modeling task section
101 to 199	- Reliability modeling tasks
1001 to 1999	- Reliability modeling methods
200	- Reliability prediction task section
201 to 299	- Reliability prediction tasks
2001 to 2999	- Reliability prediction methods

## 1.5 Revisions.

1.5.1 Standard. Any general revision of this standard which results in a revision of sections 1, 2, 3 or 4 will be indicated by a revision letter after this standard number, together with the date of revision.

1.5.2 Task sections, tasks, and methods. Revisions are numbered consecutively indicated by a letter following the number. For example, for task 101, the first revision is 101A, the second revision is 101B. When the Basic Document is revised, those requirements not affected by change retain their existing date.

1.6 Method of reference. The tasks and methods contained herein shall be referenced by specifying:

- a. This standard number
- b. Task number(s)
- c. Method number(s)
- d. Other data as called for in the individual task or method

## 2. REFERENCED DOCUMENTS

2.1 Issues of documents. The following documents of the issue in effect on date of invitation for bids or request for proposal, are referenced in this standard for information and guidance.

### STANDARDS

#### Military

MIL-STD-280	Definitions of Item Levels, Item Exchangeability, Models and Related Terms
MIL-STD-470	Maintainability Program Requirements
MIL-STD-721	Definitions of Terms for Reliability and Maintainability
MIL-STD-780	Work Unit Codes for Aeronautical Equipment; Uniform Numbering System
MIL-STD-785	Reliability Program for Systems and Equipment Development and Production
MIL-STD-881	Work Breakdown Structures for Defense Material Items
MIL-STD-882	System Safety Program Requirements



## MIL-STD-756B

## STANDARDS (Continued)

Military (Continued)

MIL-STD-1388	Logistics Support Analysis
MIL-STD-1591	On Aircraft, Fault Diagnosis, Subsystems, Analysis/Synthesis of
MIL-STD-1670	Environmental Criteria and Guidelines for Air-Launched Weapons
MIL-STD-2072	Survivability, Aircraft; Establishment and Conduct of Programs For
MIL-STD-2080	Maintenance Plan Analysis for Aircraft and Ground Support Equipments

## HANDBOOKS

Military

MIL-HDBK-217	Reliability Prediction of Electronic Equipment
MIL-HDBK-251	Reliability/Design Thermal Applications

(Copies of specifications, standards, drawings, and publications required by contractors in connection with specific procurement functions should be obtained from the procuring activity or as directed by the contracting officer.)

## PUBLICATIONS

Naval Sea Systems Command

NAVORD-OD 44622 Reliability Data Analysis and Interpretation  
Volume 4

(Application for copies should be addressed to: Commanding Officer, Naval Ship Weapon Systems Engineering Station (Code 5743), Port Hueneme, CA 93043.)

2.2 Other publications. The following documents are potential sources of reliability data that may be used in conjunction with this standard. Specific requirements for use of these or other data sources must be specified by the procuring activity.

## MIL-STD-756B

RADC-TR-73-248 (AD-768619)	Dormancy and Power On-Off Cycling Effects on Electronic Equipment and Part Reliability
RADC-TR-74-269 (AD/A-002838)	Effects of Dormancy on Nonelectronic Components and Materials
LC-78-1 (AD/A-053403)	Storage Reliability of Missile Material Program, Missile Material Reliability Handbook Parts Count Prediction

(Application for copies should be addressed to the National Technical Information Service, U.S. Department of Commerce, 5385 Port Royal Road, Springfield, VA 22161.)

GIDEP	Government Industry Data Exchange Program, Summaries of Failure Rates
-------	--

(Application for copies should be addressed to the Fleet Analysis Center, GIDEP Operations Center, Naval Weapons Station, Seal Beach, Corona Annex, Corona, CA 91720.)

NPRD-1	Nonelectronic Parts Reliability Data, 1978
--------	--

(Application for copies should be addressed to the Reliability Analysis Center, RADC/RBRAC, Griffiss AFB, NY 13441.)

### 3. DEFINITIONS

3.1 Terms. Terms used in this document are as defined in MIL-STD-280 and MIL-STD-721.

### 4. GENERAL REQUIREMENTS

4.1 General. Reliability modeling and prediction shall be planned and performed in accordance with the general requirements of this standard and the task(s) and method(s) specified by the procuring activity.

4.2 Implementation. Reliability modeling and prediction shall be initiated early in the configuration definition stage to aid in the evaluation of the design and to provide a basis for item reliability allocation (apportionment) and establishing corrective action priorities. Reliability models and predictions shall be updated when there is a significant change in the item design, availability of design details, environmental requirements, stress data, failure rate data, or service use profile. A planned schedule for updates shall be specified by the procuring activity.

## MIL-STD-756B

4.3 Ground rules and assumptions. The contractor shall develop ground rules and analysis assumptions. The ground rules shall identify the reliability modeling and prediction approach, the lowest indenture level to be analyzed, and include a definition of mission success for the item in terms of performance criteria and allowable limits. Ground rules and analysis assumptions are not inflexible and may be added, modified, or deleted if requirements change. Ground rules and analysis assumptions shall be documented and included in the reliability modeling and prediction report.

4.4 Indenture level. The indenture level applies to the item hardware or functional level at which the item configuration is defined. Unless otherwise specified, the contractor shall establish the lowest indenture level of analysis using the following guidelines:

- a. The lowest level specified for the Failure Mode, Effects, and Criticality Analysis (FMECA) to ensure consistency and allow cross referencing.
- b. The specified or intended maintenance and repair level for hardware elements of the item.

4.5 Coding system. For consistent identification of item functions and hardware elements, the contractor shall adhere to a coding system based upon the hardware breakdown structure, work unit code numbering system of MIL-STD-780, or other similar uniform numbering system. The coding system shall be consistent with the FMECA (if required) and functional block diagram numbering system to provide complete visibility of each modeled element and its relationship to the item.

4.6 Mission success definition. The contractor shall develop general statements of item mission success in terms of performance and allowable limits for each specified output. Mission success definitions shall be included in the ground rules discussed in 4.3.

4.7 Coordination of effort. Reliability and other organizational elements shall make coincident performance and use of the reliability models and predictions. Consideration shall be given to the requirements to perform and use the reliability models and predictions in support of a reliability program in accordance with MIL-STD-785, maintainability program in accordance with MIL-STD-470, safety program in accordance with MIL-STD-882, survivability and vulnerability program in accordance with MIL-STD-2072, logistics support analysis in accordance with MIL-STD-1388, maintenance plan analysis (MPA) in accordance with MIL-STD-2080, fault diagrams analysis in general accordance with MIL-STD-1591, and other contractual provisions.

4.8 General procedure. The steps set forth below define the procedure for developing a reliability model and performing a reliability prediction. Effort to develop the information for the steps below shall be closely coordinated with related program activities (such as design engineering, system engineering, maintainability, and logistics) to minimize duplications and to assure consistency and correctness.

## MIL-STD-756B

- a. Define the item for which the prediction is applicable (see 4.8.1).
- b. Define the service use (life cycle) for which item reliability will be modeled and predicted (see 4.8.2).
- c. Define the item reliability block diagrams (see 2.3 of Task Section 100).
- d. Define the mathematical models for computing item reliability (see 2.4 of Task Section 100).
- e. Define the parts of the item (see 2.2 of Task Section 200).
- f. Define the environmental data (see 2.3 of Task Section 200).
- g. Define the stress data (see 2.4 of Task Section 200).
- h. Define the failure distribution (see 2.5 of Task Section 200).
- i. Define the failure rates (see 2.6 of Task Section 200).
- j. Compute the item reliability (see 2.7 of Task Section 200).

4.8.1 Item definition. Item definition shall include performance requirements and hardware concept to the extent known at the time the model and prediction are prepared. Characteristics of the item shall be stated in terms of range, altitude, speed, maneuverability, environmental conditions, power, or such other parameters as may be applicable. The manner in which the item and its subdivision operate is usually expressed by means of functional diagrams which can become the basis for the reliability block diagrams (see 2.3 of Task Section 100). Normally, the initial item definition used for the feasibility prediction will be lacking several details and will require certain assumptions as to environmental conditions, design configuration, etc. The item definition shall be refined and updated as more information becomes available to support the preliminary design prediction, and subsequently, the detailed design prediction. As the item description is progressively updated, higher levels of accuracy will be attained for prediction results.

4.8.2 Service use profile. The service use (life cycle) profile or portion thereof to be used for reliability modeling and prediction shall either be provided by the procuring activity or specified for contractor preparation. The service use profile is a thorough description of all events and environments associated with an item from

## MIL-STD-756B

final factory acceptance through its terminal expenditure or removal from inventory. Each significant service use event, such as transportation, storage, test and checkout, operational deployment, etc., is addressed. Figure 1 illustrates the major service use events to be considered in the logistic and operational cycles. The profile depicts expected time spans, environments, operating modes (including standby and ready modes), etc., for each event. Information from logistic cycles, operational cycles, mission profiles, and environmental profiles is used to develop the service use profile.

4.8.2.1 Logistic cycle. The logistic cycle shall describe the expected duration and sequence of events which maintain, transport, and store an item to assure operational availability.

4.8.2.2 Operational cycle. The operational cycle shall describe the expected duration and sequence of events of the period from an item's assignment to an operational user through expenditure or return to some phase of the logistic cycle.

4.8.2.2.1 Mission profile. The mission profile shall describe events and conditions associated with a specific operational usage of an item. A mission profile is one segment of the operational cycle. The profile shall depict the time spans of the events and operational conditions to be anticipated. Multiple mission profiles may be required to adequately describe an item's multimission capabilities.

4.8.2.3 Environmental profile. The environmental profile shall describe the specific natural and induced environments (nominal and worst case) with the operations, events, and functions described by the logistic and operational cycles. Each mission profile shall have an associated environmental profile.

4.9 Reliability modeling and prediction report. The reliability models and reliability predictions shall be documented in a report that identifies the level of analysis, summarizes the results, documents the data sources and techniques used in performing the analysis, and includes the item definition narrative, resultant analysis data, worksheets, ground rules and assumptions. Interim reports shall be available at each design review to provide comparisons of alternative designs and to highlight high failure rate elements of the item design, potential mission reliability single failure points, and proposed design corrections or improvements. The final report shall reflect the final design and provide identification of high failure rate elements, overstressed parts, and mission reliability single failure points which could not be eliminated from the design. When submitting a report applicable for an Exploratory/Advanced Development Model, a simplified reliability modeling and prediction report is required.

4.9.1 Summary. The report shall contain a summary which provides the contractor's conclusions and recommendations based upon the analysis. Contractor interpretation and comments concerning the analysis and the initiated as recommended actions for the elimination or reduction

MIL-STD-756B

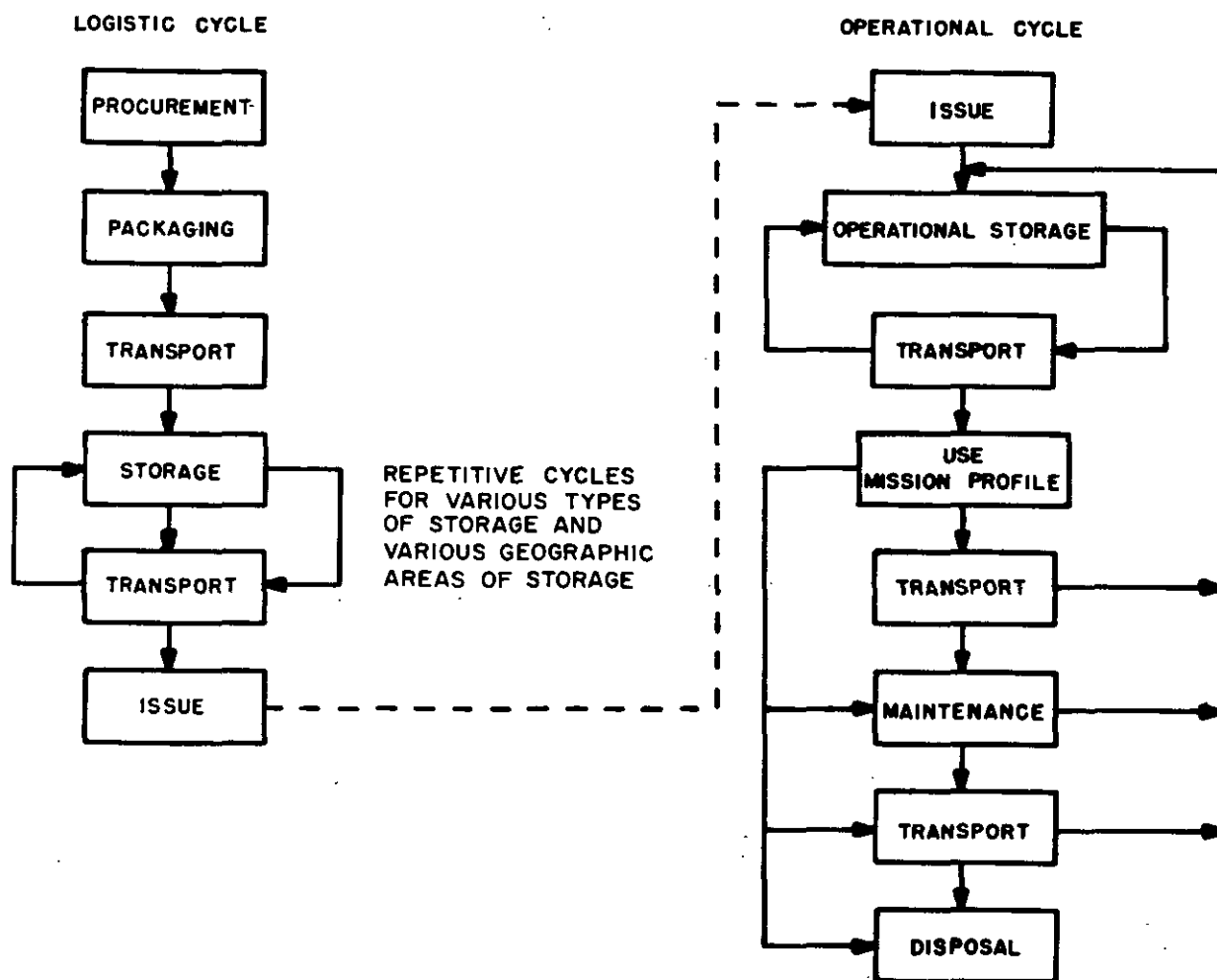

Figure 1. Service Use Events in the Logistic and Operational Cycles.

## MIL-STD-756B

of failure risks shall be included. A design evaluation summary of major problems detected during the analysis shall be provided in the final report. A list of hardware or functional elements of the item omitted from the reliability models and reliability predictions shall be included with rationale for each element's exclusion.

4.9.2 Reliability critical element lists. Reliability critical elements of the item extracted from the reliability modeling and reliability prediction effort shall be listed and included in the summary. Reliability critical elements include high failure rate elements, overstressed parts (i.e., exceed established parts derating criteria), and mission reliability single failure points.

## 5. DETAIL REQUIREMENTS

5.1 Task description and methods. The detail tasks and methods for preparing reliability models and performing reliability predictions follow. The task descriptions and methods are divided into two general sections: Section 100, Reliability Modeling; and Section 200, Reliability Prediction.

5.1.1 Details to be specified. The "Details to be Specified" paragraph under each Task Section is intended for listing the specific details, additions, modifications, deletions, or options to the requirements of the tasks covered by the section that should be considered by the Preparing Activity (PA) when tailoring the task description to fit program needs. "Details" annotated by an "(R)" ARE ESSENTIAL and shall be provided the contractor for proper implementation of the task.

### Custodians:

Army - CR  
Navy - AS  
Air Force - 17

### Preparing Activity:

Navy - AS  
Project No. RELI-0001

### Review Activities:

Army - EA, AR  
Navy - SH, OS

### Users:

Army - AM  
Navy - EC  
National Security Agency - NS  
Defense Mapping Agency - DMA

## MIL-STD-756B

## TASK SECTION 100

## RELIABILITY MODELING

## 1. DOCUMENTS REFERENCED IN TASK SECTION 100:

## STANDARDS

MILITARY

MIL-STD-780	Work Unit Codes for Aeronautical Equipment; Uniform Numbering System
MIL-STD-881	Work Breakdown Structures for Defense Material Items

## 2. REQUIREMENTS

2.1 Basic Reliability model. The Basic Reliability model shall consist of a reliability block diagram and an associated mathematical model. By definition, the Basic Reliability model is an all series model which includes elements of the item intended solely for redundancy and alternate modes of operation.

2.2 Mission Reliability model. The Mission Reliability model shall consist of a reliability block diagram and an associated mathematical model. The Mission Reliability model shall be constructed to depict the intended utilization of the elements of the item to achieve mission success. Elements of the item intended for redundancy or alternate modes of operation shall be modeled in a parallel configuration or similar construct appropriate to the mission phase and mission application.

2.3 Reliability block diagrams. Reliability block diagram shall be prepared to show interdependencies among all elements (subsystems, equipments, etc.) or functional groups of the item for item success in each service use event. The purpose of the reliability block diagram is to show by concise visual shorthand the various series-parallel block combinations (paths) that result in item success. A complete understanding of the item's mission definition, and service use profile is required to produce the reliability diagram.

2.3.1 Block diagram title. Each reliability block diagram shall have a title including identification of the item, the mission identification or portion of the service use profile addressed, and a description of the mode of operation for which the prediction is to be performed.

2.3.2 Statement of conditions. Each reliability block diagram shall include a statement of conditions listing all constraints which influence the choice of block presentation, the reliability parameters or reliability variables utilized in the analysis, and the assumptions or simplifications utilized to develop the diagram. Once established, these conditions shall be observed throughout the analysis.



## MIL-STD-756B

2.3.3 Statement of success. A statement of success shall be defined in specific terms stating exactly what the calculated reliability represents for the items as diagrammed and performing under the criteria presented in the statement of conditions.

2.3.4 Order of the diagram. The blocks in the diagram shall follow a logical order which relates the sequence of events during the prescribed operation of the item.

2.3.5 Block representation. The reliability block diagram shall be drawn so that each element or function employed in the item can be identified. Each block of the reliability block diagram shall represent one element of function contained in the item. All blocks of the reliability block diagram shall be configured in series, parallel, standby, or combinations thereof as appropriate.

2.3.6 Identification of blocks. Each block of the reliability block diagram shall be identified. Diagrams containing few blocks may have the full identification written in the block. Diagrams containing many blocks shall use a consistent and logical code identification written for each block. The coding system shall be based upon the work breakdown structure of MIL-STD-881, work unit code numbering system of MIL-STD-780, or other similar uniform identification system that will permit unambiguous traceability of the reliability block to its hardware (or functional) equivalent as defined in program documentation. The code shall be identified in a separate listing.

2.3.6.1 Non-modeled elements. Hardware or functional elements of the item which are not included in the reliability model shall be identified in a separate listing utilizing the coding system employed in 2.3.6 of Task Section 100. Rationale for each element's exclusion from the reliability model shall be provided.

2.3.7 Reliability variable. Reliability variables shall be determined for each block and presented in such a manner that the association between the block and its variable is apparent. The reliability variable is a number (time, cycles, events, etc.) used to describe the duration of operation required by each block to perform its stated function. This variable shall be used in calculating the reliability of the block.

2.3.8 Block diagram assumptions. Two types of assumptions shall be used in preparing reliability block diagrams: (1) technical and (2) general. Technical assumptions may be different for each item and for each mode of operation. The technical assumptions shall be set forth under the statement of conditions. The general assumptions are those applicable to all reliability block diagrams. It is not necessary to list the general assumptions stated in this standard on the reliability block diagrams, provided reference has been made to this paragraph. The following general assumptions shall apply to reliability block diagrams:

## MIL-STD-756B

- a. The blocks denote elements or functions of the items that are considered when evaluating reliability and which have reliability values associated with them.
- b. All lines connecting blocks have no reliability values. The lines serve only to give order and direction to the diagram and do not represent the wiring cables and connectors associated with the item. Cabling and connectors are incorporated into a single block or included as part of the block for an element or function.
- c. All inputs to the item are within specification limits.
- d. Failure of any element or function denoted by a block in the diagram will cause failure of the entire item, except where alternative modes of operation may be present.
- e. Each element or function denoted by a block in the diagram is independent, with regard to probability of failure, from all other blocks.

2.3.8.1 Software reliability assumption. The assumption that all software is completely reliable shall be stated in instances when software reliability is not incorporated in the item reliability prediction.

2.3.8.2 Human reliability assumption. The assumption that all human elements are completely reliable and that no interface problems occur between human elements and the item shall be stated in instances when human reliability is not incorporated in the item reliability prediction.

2.4 Mathematical models. Models shall be derived to mathematically relate reliability block diagrams to time-event relationships and failure rate data. The solution of the models will be the item predicted reliability. The mathematical model shall be capable of being readily updated with information resulting from reliability and other relevant tests as well as changes in item configuration, mission parameters and operational constraints.

3. Details to be specified by the Preparing Activity (PA) (See 5.1.1). The following are applicable when Task 101 or 102 are invoked:
  - a. Indenture level (4.4)
  - b. Software Reliability Applicability (2.3.8.1 of Task Section 100).
  - c. Human Reliability Applicability (2.3.8.2 of Task Section 100).

MIL-STD-756B

- (R) d. Modeling Method(s). An option is to allow contractor selection of the appropriate modeling method(s). Different prediction methods may be applicable to different system components.
- e. DI-R-7094 Reliability Mathematical Models should be specified when deliverable data is desired in conjunction with this task.
- (R) f. Item definition (4.8.1).
- (R) g. Service use profile (4.8.2).

## MIL-STD-756B

## TASK SECTION 200

## RELIABILITY PREDICTION

## 1. DOCUMENTS REFERENCED IN TASK SECTION 200:

## STANDARDS

Military

MIL-STD-1670 Environmental Criteria and Guidelines for Air-Launched Weapons

## HANDBOOKS

Military

MIL-HDBK-217 Reliability Prediction of Electronic Equipment

MIL-HDBK-251 Reliability/Design Thermal Applications

## OTHER PUBLICATIONS

RADC-TR-73-248 Dormancy and Power On-Off Cycling Effects on Electronic Equipment and Part Reliability

RADC-TR-74-269 Effects of Dormancy on Nonelectronic Components and Materials

LC-78-1 Storage Reliability of Missile Material Program, Missile Material Reliability Handbook Part Count Prediction

GIDEP Government Industry Data Exchange Program, Summaries of Failure Rates

NPRD-1 Nonelectronic Parts Reliability Data, 1978

## 2. GENERAL REQUIREMENTS

2.1 Classification. Reliability predictions, as defined herein, are classified as follows:

- Type I - Feasibility prediction
- Type II - Preliminary design prediction
- Type III - Detailed design prediction

## MIL-STD-756B

Generalized descriptions of predictions specified by this standard will be found in the following paragraphs. Examples of reliability prediction methods appropriate for the three types of predictions are provided by Methods 2001 through 2005. The applicability of individual requirements of Section 200 herein is a function of the type of prediction to be performed; the steps delineated will be performed to the extent permitted by the level of design configuration data available. Unless otherwise specified, the reliability prediction shall be for worst case operating and environmental conditions.

2.1.1 Feasibility prediction (Type I). Feasibility prediction is intended for use in the conceptual phase of item development. During this phase the level of detailed design information is generally restricted to overall aspects of the item. Detailed configuration data generally are limited to that which may be derived from existing items having functional and operational requirements similar to those of the item being developed. Methods 2001, 2002, and 2003 describe feasibility prediction methods.

2.1.2 Preliminary design prediction (Type II). Preliminary design prediction is intended for use in the early detailed design phase. During this phase design configuration data are documented by engineering sketches and preliminary drawings. The level of detailed information available may be restricted to part listings. Stress analysis data are not generally available. Method 2004 describes a preliminary design prediction method.

2.1.3 Detailed design prediction (Type III). Detailed design prediction is intended for use in and subsequent to the detailed design phase. This phase is characterized by drawings which identify all parts, materials, and processes needed to produce the item. Operating stress and temperature analysis data are necessary for each part in the item. The analysis data shall be based on design analysis and measurement techniques acceptable to the procuring activity. Method 2005 describes a detailed design prediction method.

2.2 Part description. Part and application descriptions shall be provided for any prediction based upon part failure rates. The part identification number from the schematic diagram, the applicable specification and the specification type number shall be included.

2.3 Environmental data. Environmental data affecting part failure rates must be defined. These data include the specific natural and induced environments (nominal and worst case) associated with the operations, events, and functions described by the logistic and operational cycles. Guidelines for determining the environmental conditions of use for air-launched weapons are found in MIL-STD-1670.

## MIL-STD-756B

2.3.1 Environmental categories. Environmental categories shall be defined for each service use event using Table 200-I as a guide of typical categories. Data sources, such as MIL-HDBK-217 and NPRD-1 which utilize environmental factors to adjust failure rates, shall apply the environmental factor which most closely matches the intended environment. Factors utilized shall be cited and substantiated.

2.3.2 Part operating temperature. Part temperatures used for prediction purposes shall include the item internal temperature rise as determined by thermal analysis or test data. For general guidance and detailed thermal analysis procedures, refer to MIL-HDBK-251.

2.4 Stress analysis. Analyses shall be performed to determine the operating stresses to be experienced by each part commensurate with the prediction classification and the design detail available. These analyses shall be based on techniques acceptable to the procuring activity. Failure rates shall be modified by appropriate factors to account for the effect of applied stress. Stress ratios cited in the prediction report shall be individually identified as Estimated (E), Calculated (C), or Measured (M).

2.5 Failure distributions. The failure distribution appropriate to the specific electronic, electrical, electromechanical, mechanical, and ordnance item shall be used in computation. In instances where the failure distribution for the item is not known, the exponential, binominal, weibull, or other failure distribution may be assumed. The failure distributions utilized shall be cited and any assumptions substantiated in the prediction report.

2.6 Failure rates. Failure rates for all electronic, electrical, electromechanical, mechanical, and ordnance items are required for each significant event and environment defined by the service use profile. All sources of failure data shall be approved by the procuring activity prior to use. Basic failure rates from most data sources must be modified with appropriate factors to account for the specific item application under consideration. Factors used shall be cited and substantiated in the prediction report.

2.6.1 Functional group failure rates. Functional group failure rates may be derived from failure rate data for functionally similar groups or items. The GIDEP Failure Rate Summaries are an available source for locating group and item failure rates.

2.6.2 Operating failure rates. Operating failure rates for electronic and electromechanical parts may be found in MIL-HDBK-217. Failure rates for other parts may be found in NPRD-1, the GIDEP Failure Rate Summaries, and other sources.

## MIL-STD-756B

2.6.3 Nonoperating failure rates. Nonoperating failure rates for parts take into consideration pertinent environmental influences or other stresses of the application. Data sources such as RADC-TR-73-248, RADC-TR-74-269, and LC-78-1 provide nonoperating failure rates.

2.6.4 Storage failure rates. Storage failure rates for parts may be found in data sources such as RADC-TR-73-248, RADC-TR-74-269, and LC-78-1.

2.7 Item reliability. Item reliability shall be computed using mathematical models and applicable failure rate data. The prediction results shall be expressed in terms consistent with the specified reliability requirements.

3. DETAILS TO BE SPECIFIED BY THE PA (SEE 5.1.1). The following are applicable when Tasks 201 or 202 are involved:

- a. Since reliability modeling tasks are normally prerequisite tasks to prediction tasks, elements in 3 of Task Section 100 apply.
- (R) b. Prediction Type (See 2.1 of Task Section 200).
- c. Worst Case Applicability (See 2.1 of Task Section 200).
- d. Environmental Categories (See 2.3.1 of Task Section 200).
- e. Stress Analysis Applicability (See 2.4 of Task Section 200).
- f. Failure Rate Data Sources (See 2.6 of Task Section 200).
- g. Item Reliability Requirements (See 2.7 of Task Section 200).
- h. DI-R-7095 (Reliability Prediction and Documentation of Supporting Data) should be specified when deliverable data is desired in conjunction with this task.
- (R) i. Prediction Method(s). An option is to allow contractor selection of the appropriate prediction method(s). Different prediction methods may be applicable to different system components.

## MIL-STD-756B

Table 200-I. Environmental Symbol Identification and Description.

Environment	Symbol	Nominal Environmental Conditions
Ground, Benign	G <sub>B</sub>	Nearly zero environmental stress.
Space, Flight	S <sub>F</sub>	Earth orbital. Approaches Ground, Benign conditions. Vehicle neither under powered flight nor in atmospheric reentry.
Ground, Fixed	G <sub>F</sub>	Conditions less than ideal to include installation in permanent racks with adequate cooling air and possible installation in unheated buildings.
Ground, Mobile	G <sub>M</sub>	Conditions more severe than those for G <sub>F</sub> , mostly for vibration and shock. Cooling air supply may also be more limited.
Naval, Sheltered	N <sub>S</sub>	Surface ship conditions similar to G <sub>F</sub> but subject to occasional high shock and vibration.
Naval, Unsheltered	N <sub>U</sub>	Nominal surface shipborne conditions but with repetitive high levels of shock and vibration.
Airborne, Inhabited, Transport	A <sub>IT</sub>	Typical conditions in transport or bomber compartments occupied by aircrew without environmental extremes of pressure, temperature, shock and vibration, and installed on long mission aircraft such as transports and bombers.
Airborne, Inhabited, Fighter	A <sub>IF</sub>	Same as A <sub>IT</sub> but installed on high performance aircraft such as fighters and interceptors.
Airborne, Inhabited, Helicopter	A <sub>IH</sub>	Same as A <sub>IT</sub> but installed on rotary wing aircraft such as helicopters.
Airborne, Uninhabited, Transport	A <sub>UT</sub>	Bomb bay, equipment bay, tail, or wing installations where extreme pressure, vibration and temperature cycling may be aggravated by contamination from oil, hydraulic fluid and engine exhaust. Installed on long mission aircraft such as transports and bombers.
Airborne, Uninhabited, Fighter	A <sub>UF</sub>	Same as A <sub>UT</sub> but installed on high performance aircraft such as fighters and interceptors.
Airborne, Uninhabited, Helicopter	A <sub>UH</sub>	Same as A <sub>UT</sub> but installed on rotary wing aircraft such as helicopters.
Missile, Launch	M <sub>L</sub>	Severe conditions of noise, vibration, and other environments related to missile launch, and space vehicle boost into orbit, vehicle re-entry and landing by parachute. Conditions may also apply to installation near main rocket engines during launch operations.
Missile, Captive Carry	M <sub>C</sub>	Same as A <sub>IT</sub> , A <sub>UF</sub> or A <sub>UH</sub> depending on the applicable aircraft platform.
Missile, Free Flight	M <sub>F</sub>	Typical conditions of pressure, vibration and temperature experienced in atmospheric flight to target.



MIL-STD-756B

TASK 101

BASIC RELIABILITY MODEL

1. PURPOSE/RATIONALE

1.1 A Basic Reliability model is a series model used for estimating the demand for maintenance and logistic support caused by an item and its component parts. Accordingly, all elements of the item provided for redundancy or alternate modes of operation are modeled in series. Except for those instances in which there is neither redundancy nor alternate modes of operation provided for the item, the Basic Reliability model cannot be used to estimate Mission Reliability. However, both the Basic Reliability model and the Mission Reliability model are used in combination to compare the ownership cost-effectiveness of various design configurations and as a basis for apportionment (allocation) of ownership cost and operational effectiveness requirements to various subdivisions of an item.

1.2 The basic information for the Basic Reliability model is derived from documentation identifying all equipments and associated quantities that comprise the item. As the proposed item design is firmed and comes under configuration control, the established configuration baseline should be the basis for the Basic Reliability model.

1.3 The Basic Reliability model should be developed to the level of detail (equipment, subassembly, or part level) for which information is available and for which failure rate, (or equivalent), data can be applied to evaluate the maintenance and logistic support impact of the item design.

1.4 Together with duty cycle and mission duration, information, the Basic Reliability model is used to develop mathematical expressions or computer programs which, with appropriate failure rate data, can provide apportionment, estimates and assessments of Basic Reliability.

2. REQUIREMENT

2.1 The contractor shall develop and maintain a Basic Reliability model based upon a defined item configuration. All equipments and associated quantities comprising the item shall be included in the model. All equipments, including those intended solely for item redundancy and alternate modes of operation, shall be modeled in series. A Basic Reliability block diagram shall be developed and maintained for the item with associated allocations and predictions in each reliability block. The Basic Reliability block diagram shall be keyed and traceable to the Mission Reliability model, functional block diagrams, schematics and drawings, and shall provide the basis for accurate mathematical representation of Basic Reliability. Nomenclature of elements of the item used in the Basic Reliability block diagrams shall be consistent with that used in the Mission Reliability model, functional block diagrams, drawings and schematics, weight statements, power budgets and specifications.

## MIL-STD-756B

## TASK 102

## MISSION RELIABILITY MODEL

## 1. PURPOSE/RATIONALE

1.1 A Mission Reliability model is used for evaluating complex series-parallel equipment arrangements which usually exist in weapon systems.

## 2. MISSION RELIABILITY MODELING

2.1 How to Define the Item for Modeling. A prerequisite for developing Mission Reliability models is understanding the definition of the item as related to the definition of reliability. For Basic Reliability modeling, the item definition is simple - all equipments comprising the item are modeled in series. "All" equipments includes any equipments provided solely for redundancy or for alternate modes of operation. However, for Mission Reliability modeling, the item reliability model and mission success definition can become elusive problems especially for complex multimodel systems incorporating redundancies and alternate modes of operation. In item definition, emphasis is placed on properly specifying reliability within the context of all other pressing requirements and restraints that comprise a functioning item. A proper definition is important in order to establish meaningful requirements and goals. An adequate item definition aids in determining when the item is being used as intended, when it sees its anticipated environment, when its configuration has been changed beyond its original concept, as well as when it is performing its specified function. Item reliability is defined as the probability of performing a specified function or mission under specified conditions for a specified time. Therefore, a reliability requirement for function or mission success must include:

- a. A definition of item performance such that every condition is defined as acceptable (success) or unacceptable (failure). Obviously, item modes of operation must be known to define success and failure. For example, simultaneous transmission of real time and stored data might be defined as success for one item, while another item may not require simultaneous transmission of real time and stored data. If the latter item had two transmitters for sending data they would be considered redundant, or provide an alternate mode of operation. In the former item, however, the requirement rules out this alternate mode of operation. Another item requirement might be that a certain data rate or amount of data be transmitted from a satellite to earth. Analysis of the item may show that if some channels in a multiplexer fail, the required data rate or amount of data is still achieved. This condition would be defined as success.

## MIL-STD-756B

- b. A definition of the conditions. This involves defining the environmental conditions which prevail on the various equipments of the item throughout the mission. In addition, duty cycle or periods of operation for the various equipments must be defined.
- c. A definition of mission time. A careful quantitative statement of the time during which the item must function is important. In complex items which operate in different functional modes at different stages of the mission or which use certain subsystems only if conditions require, the functioning-time requirements for each subordinate group should be established. If the time requirements cannot be specified definitely, it may be necessary to determine probabilities of successful functioning during a range of mission times.
- d. A definition of the reliability variable of the item elements. The reliability variable is a number (time, cycles, events, etc.) used to describe the duration required by each item element (and included in the Mission Reliability block diagram) to perform its stated function.

2.2 Developing the Item Definition. A complete definition of the item covers the use, performance, restraints, and failure definitions. Thus, it is necessary to define:

- a. Purpose, intended use, or mission.
- b. Performance parameters and allowable limits.
- c. Physical and functional boundaries.
- d. Conditions which constitute mission failure.
- e. Service use profile.

Step 1 - Define the purpose and intended use or mission of the item.

This includes:

- a. Defining mission functions and modes of operation. A particular item can be utilized for more than one type mission. For example, an aircraft may be used on a military reconnaissance mission, a bombing mission, an intercept mission, or a strafing mission. If separate aircraft were used for these missions, they would be treated independently, with a separate Mission Reliability model for each mission or aircraft. If the same aircraft were used to perform all these missions, they could be treated as functions and one item reliability model could be generated to cover all functions. It is also possible to have separate reliability requirements and models for each mission.

## MIL-STD-756B

- b. Defining the mission in terms of performing functions. For purpose of clarity, functional and alternate modes of operation have been defined below.
1. Functional Mode of Operation - Some versatile items perform multiple functions with different equipment or groups of equipment being required for each function. A function is a task to be performed by the hardware and therefore, a functional mode of operation consists of performing a specific function. For example, in a radar system, searching and tracking would be two functional modes of operation.
  2. Alternative Modes of Operation - When an item has more than one method of performing a particular function, it has alternative modes of operation. For example, a UHF transmitter may be used as an alternative method of communicating data sent normally via a VHF transmitter.

Before a model can be developed, requirements must be formulated. A word statement of what is required for mission success or a Mission Reliability block diagram must be generated. The Mission Reliability block diagram is a pictorial form of a statement of what is required for mission success. When requirements are not firm, it is possible to develop several Mission Reliability models assuming different requirements. In other words, a family of item reliability diagrams can be generated for various requirements for mission success.

Step 2 - Establish and specify the item and subsystem performance parameters and allowable limits.

It is desirable to construct a list or chart for convenience. The list of parameters should be all inclusive, completely defining the entire item under consideration. The allowable upper and lower limits for these parameters should be developed. Columns (1), (2), and (3) of Figure 102.1 illustrate a list of performance parameters and allowable limits.

Performance Parameter (1)	Units of Measure (2)	Specified Requirement (3)	Failure Classification in Terms of Performance Limits (4)
1. Power output (PO)	Horsepower, Kilowatts, etc.	PO=500±20%	Major: 200<PO<400 Critical: PO<200
2. Channel capacity (n)	Number of channels	n=48+0	Major: 24<n<40 Critical: n<24
3. Voltage gain (A)	Decibels	A=40±3db	Major: 30<A<37 Critical: A<30
4. Detection range (H)	Nautical miles	H=300+0 -50	Major: 150<H<250 Critical: H<150
5. Miss distance (d <sub>m</sub> )	Meters	d <sub>m</sub> =0+10 - 0	Major: 20>d <sub>m</sub> >10 Critical: d <sub>m</sub> >20

Figure 102.1. Performance Parameters, Limits, and Failure Criteria.

## MIL-STD-756B

Step 3 - Determine the physical and functional boundaries of the item.

Physical boundaries:

- a. Maximum dimensions.
- b. Maximum weight.
- c. Safety provisions.
- d. Human factors restraints.
- e. Materials capabilities.
- f. etc.

Functional boundaries:

- a. Whenever the item under consideration is contained in or depends upon another item, item interfaces must be coordinated for compatibility. Examples include man-machine interfaces, interface with ships central control, power sources, data requirements, etc.

Step 4 - Determine the conditions which constitute mission failure.

A failure is an inability to complete a stated mission within specific limits. Using the previous steps, identify and list the conditions that would constitute mission failure. For example, one condition of successful mission completion may be a requirement of a minimum 200 kilowatts (KW) for the power output of a transmitter. Hence, any single or combination of item hardware and software failure(s) that would result in less than 200 KW of transmitter power output would constitute a mission failure. Column (4) of Figure 102.1 illustrates a definition of failure criteria.

In certain instances where a failure condition exists, a mission can still be completed in a somewhat limited manner. In these instances it is usually worthwhile to identify the mission options available as a result of a prime mission failure condition.

Step 5 - Define the service use profile.

The service use profile is a thorough description of all events and environments associated with an item from final acceptance through its terminal expenditure or removal from inventory. The profile depicts expected time spans, environments, operating modes (including standby and ready modes), etc., for each event. Although the Mission Reliability model should, and often does, consider the complete logistic and operational cycles associated with the service use profile it is the mission profile and environmental profile that receives the most attention.

## MIL-STD-756B

- a. The mission profile describes events and conditions associated with a specific operational usage of an item. Multiple mission profiles may be required to adequately describe an item's multimission capabilities. The mission profile(s) needs to address the item duty cycles or periods of operation. The item should be subdivided into components or equipments and a plot of the intended use through time for each component or equipment should be developed. Duty cycle is the ratio of operating time to total time. The method to handle duty cycle in calculations is as follows:

1. If the component is considered to have a negligible failure rate during a non-operation period, the failure rate can be modified by a duty cycle factor. For example the equation  $P_s = e^{-\lambda t d}$  can be used for a constant failure rate component where  $d$ , the duty cycle factor, is the ratio of operating time to total mission time,  $t$ .
2. When a component has a failure rate during non-operating periods different from that experienced during operating periods, the following equation can be used:

$$P_s = P_s \text{ (operating)} \cdot P_s \text{ (nonoperating)}$$

For the constant figure rate component, this equation yields

$$P_s = e^{-[\lambda_1 t d + \lambda_2 t (1-d)]}$$

Where

$\lambda_1$  = failure rate during operation

$\lambda_2$  = failure rate during non-operation

- b. An environmental profile describes the specific natural and induced environments (nominal and worst case) associated with the operations, events, and functions described by the operational cycle.

Items can be utilized in more than one environment. For example, a given item might be used at a ground site, on shipboard, and in an airborne environment. In addition, a given mission may consist of several phases of operation. A phase of operation is a period of time during which a given environment prevails. For example, in a satellite, boost, orbit, reentry, and recovery with their associated environments are phases of operation.

## MIL-STD-756B

These environmental considerations are handled as follows in Mission Reliability models.

1. For items having more than one end use, each with a different environment, the Mission Reliability model would be the same for all environments except that the failure rates for the various equipments of the item would be different for the various environments.
2. For items having several phases of operation, separate Mission Reliability models can be generated and predictions made for each phase of operation. The results can then be combined into an overall item model and item prediction.

### 2.3 How To Construct a Mission Reliability Model

2.3.1 Fundamental rules for probability computations. This section discusses the fundamental rules for probability computations that provide the basis for the derivation of the probability of survival ( $P_S$ ) equations developed in Method 1001.

2.3.1.1 The addition rule (exclusive case). If A and B are two mutually exclusive events, i.e., occurrence of either event excludes the other, the probability of either of them happening is the sum of their respective probabilities:

$$P(A \text{ or } B) = P(A + B) = P(A) + P(B) \quad (1)$$

This rule can apply to any number of mutually exclusive events:

$$P(A + B \dots + N) = P(A) + P(B) \dots + P(N) \quad (2)$$

2.3.1.2 The addition rule (non-exclusive case). If A and B are two events not mutually exclusive, i.e., either or both can occur, the probability of at least one of them occurring is:

$$P(A \text{ or } B) = P(A + B) = P(A) + P(B) - P(AB) \quad (3)$$

The equation for three events becomes:

$$\begin{aligned} P(A + B + C) &= P(A) + P(B) + P(C) \\ &\quad - P(AB) - P(AC) - P(BC) \\ &\quad + P(ABC) \end{aligned} \quad (4)$$

This rule can be extended to any number of events.

## MIL-STD-756B

2.3.1.3 The multiplication rule. If events A and B are independent, i.e., the occurrence of one does not affect the probability of occurrence of the other, the probability that both will occur is equal to the product of their respective probabilities.

$$P(A \text{ and } B) = P(AB) = P(A) P(B) \quad (5)$$

Equation (5) may be extended to any number of independent events:

$$P(AB\dots N) = P(A) P(B)\dots P(N) \quad (6)$$

2.3.1.4 Conditional probabilities. If events A and B are not independent, i.e., the occurrence of one affects the probability of occurrence of the other, a conditional probability exists. The probability of A given that B has occurred is denoted by  $P(A|B)$ , and similarly B given A is denoted by  $P(B|A)$ . Thus, if A and B are not independent, then the probability of both occurring is:

$$P(AB) = P(A) P(B|A) = P(B) P(A|B) \quad (7)$$

If A and B are independent,  $P(A|B) = P(A)$  and  $P(B|A) = P(B)$  and Equation (7) reduces to Equation (5).

For three events, A, B and C

$$P(ABC) = P(A) P(B|A) P(C|AB) \quad (8)$$

### 2.3.2 Procedure for developing item models.

- Step 1 - Define what is required for mission success and translate this into a mission success diagram.
- Step 2 - Write the probability of success,  $P_S$ , equation for the item.
- Step 3 - Calculate  $P_S$  for each of the equipments of the item. This is done by utilizing one of the various reliability prediction techniques.
- Step 4 - The probability of success numbers for the various equipments derived in Step 3 are inserted in the formula derived in Step 2 for the item probability of success.
- Step 5 - A probability of success curve versus time can be plotted by taking several values of time for mission time, and evaluating the probability of item success by the above procedure for the several values of time chosen.
- Step 6 - Additional steps in the analysis will depend upon the decisions that the analysis is intended to optimize.



## MIL-STD-756B

2.4 Discussion of procedure. As described in 1.2 of Task 102 it is necessary to define the specific mission of interest (if more than one exists), the phases of operation, the functions and alternate modes of operation to perform these functions.

Defining mission success is tantamount to writing a word statement which describes what equipments or combinations of equipments are required for mission success and drawing a reliability block diagram for the statement. Several methods of going from a reliability block diagram to a probability of survival formula are shown in this section.

For example, a word statement might be:

Equipments A, B, and C, or D and E, and equipment F must work for mission success. The Mission Reliability block diagram would be as follows:

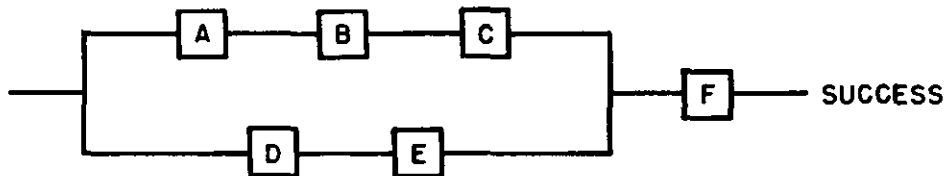

It is not convenient to go directly from this Mission Reliability diagram to a probability of success equation for the system. The correct probability of survival equation is:

$$P_S = P_A P_B P_C P_F + P_D P_E P_F - P_A P_B P_C P_D P_E P_F \quad (9)$$

At first it might appear that the probability of success equation could be written as

$$P_S = P_A P_B P_C P_F + P_D P_E P_F$$

where  $P_A$  = probability of equipment A working.

The event that A, B, C, and F works (represented by ABCF) and that the event D, E, and F works (represented by DEF) are not mutually exclusive. Consequently, adding the probabilities of these two events,  $P_A P_B P_C P_F + P_D P_E P_F$  does not yield the correct result.

Another word statement could be that any two of three generators A, B, and C must work for success. In other words, the generators are physically operating in parallel and any two have the capability to supply the needs of the system. Its mission success diagram may be shown in one of two ways:



## MIL-STD-756B

## TASK 201

## BASIC RELIABILITY PREDICTION

## 1. PURPOSE/RATIONALE

1.1 A Basic Reliability prediction utilizes a series model for estimating the demand for maintenance and logistic support caused by an item and its component parts.

1.2 The Basic Reliability prediction is used in conjunction with a Mission Reliability prediction. Whereas the Mission Reliability prediction indicates the capability of the item design to successfully accomplish mission objectives, the Basic Reliability prediction indicates the degree of maintenance and logistic support burden to be anticipated due to item unreliability. It would be expected that for alternative item design configurations with equivalent mission reliability and technical development risk, the item design configuration with the higher support reliability is the preferred design for enhancing operational readiness and minimizing the costs associated with maintenance and logistics support. In certain instances, a design configuration with less mission reliability than other design configurations may be preferred if the design's Basic reliability is significantly better than the competing design.

1.3 A Basic Reliability prediction should be prepared as soon as possible and updated whenever changes in design or data occur. While early predictions are inherently unrefined because of insufficient design detail, they provide useful feedback to designers and management in either establishing reliability requirements in the form of apportionments (allocations) or the feasibility of meeting reliability requirements.

1.4 As the item progresses from paper design to hardware stages, predictions evolve into assessments as actual program test data become available and are integrated into the calculations. The validity of both predictions and assessments is a function of data quality and assumptions. Valid, timely analyses projecting or indicating deficient reliability attainment provide the basis for corrective action, and the sooner that corrective action is identified, the less its implementation is impacted by program constraints, and the higher are the payoffs over the life of the item.

1.5 The prediction and assessment tasks, iterative and interrelated with activities such as reliability allocation and configuration analyses, should be specified by the procuring activity during the early acquisition phases to determine reliability feasibility and, during the development production phases, to determine reliability acceptability.

## 2. REQUIREMENT

2.1 The contractor shall prepare, and maintain a Basic Reliability prediction based upon a defined configuration and an associated Basic Reliability model. All equipments and associated quantities comprising

## MIL-STD-756B

the item shall be included in the model except for documented exclusions approved by the procuring activity. Failure rate data (or equivalent reliability parameters) shall be consistent with the level of detail of the Basic Reliability model and availability of procuring activity approved relevant data sources for a comprehensive prediction (e.g., software reliability, human reliability, storage reliability, etc.).

2.2 When required, predictions shall account for, and differentiate between, each mode of item operation as defined in the item specification. Predictions shall be made showing the capability of the item to meet all reliability requirements specified by the procuring activity. The prediction shall be based upon the worst-case service use profile unless otherwise specified.

2.3 All data sources for failure rates, failure distribution and failure rate adjustment factors (e.g., stress factors, duty cycle, etc.) shall be identified for each reliability block. Data sources shall be as specified or otherwise approved by the procuring activity.

MIL-STD-756B

TASK 202

MISSION RELIABILITY PREDICTION

1. PURPOSE/RATIONALE

1.1 A Mission Reliability prediction normally utilizes a complex series-parallel model for estimating an item's capability to successfully perform specified mission objectives.

1.2 The Mission Reliability prediction is used in conjunction with a Support Reliability prediction. Whereas the Mission Reliability prediction indicates the capability of the item design to successfully accomplish mission objectives, the Support Reliability prediction indicates the degree of maintenance and logistic support burden to be anticipated due to item unreliability. Obviously, for alternative item design configurations with equivalent mission reliability and technical development risk, the item design configurations with the higher support reliability is the preferred design for enhancing operational readiness and minimizing the costs associated with maintenance and logistics support. In certain instances, a design configuration with less mission reliability than other design configurations may be preferred if the design's support reliability is significantly better than the competing design.

1.3 A Mission Reliability prediction should be prepared as soon as possible and updated whenever changes in design or data occur. While early predictions are inherently unrefined because of insufficient design detail, they provide useful feedback to designers and management in either establishing reliability requirements in the form of apportionments (allocations) or the feasibility of meeting reliability requirements.

1.4 As the item progresses from paper design to hardware stages, predictions evolve into assessments as actual program test data become available and are integrated into the calculations. The validity of both predictions and assessments is a function of data quality and assumptions. Valid, timely analyses projecting or indicating deficient reliability attainment provide the basis for corrective action, and the sooner that corrective action is identified, the less its implementation is impacted by program constraints, and the higher are the payoffs over the life of the item.

1.5 The prediction and assessment tasks, iterative and interrelated with activities such as reliability allocation and configuration analyses, should be specified by the procuring activity during the early acquisition phases to determine reliability feasibility and, during the development and production phases, to determine reliability acceptability.

MIL-STD-756B

2. REQUIREMENT

2.1 The contractor shall prepare and maintain a Mission Reliability prediction based upon a defined configuration and an associated Mission Reliability model. All equipments and associated quantities comprising the item shall be included in the model except for documented exclusions approved by the procuring activity. The prediction shall reflect design provisions for item redundancies and alternate modes of operation intended to enhance mission success. Failure rate data (or equivalent reliability parameters) shall be consistent with the level of detail of the Mission Reliability model and availability of procuring activity approved relevant data sources for a comprehensive prediction (e.g., software reliability, human reliability, storage reliability, etc.).

2.2 When required, predictions shall account for, and differentiate between, each mode of item operation as defined in the item specification. Predictions shall be made showing the capability of the item to meet all reliability requirements specified by the procuring activity. The prediction shall be based upon the worst case service use profile unless otherwise specified.

2.3 All data sources for failure rates, failure distributions and failure rate adjustment factors (e.g., stress factors, duty cycle, etc.) shall be identified for each reliability block. Data sources shall be as specified or otherwise approved by the procuring activity.

## MIL-STD-756B

## METHOD 1001

## CONVENTIONAL PROBABILITY

1. **PURPOSE.** The purpose of the conventional probability method is to prepare a reliability mathematical model from a reliability block diagram by means of conventional probability relationships. The conventional probability method is applicable to single functioned and multifunctioned systems.

2. **PROCEDURE.**

2.1 **Single functioned systems.** Single functioned systems consist of equipments considered to have a single function associated with equipment performance. The single functioned system Mission Reliability diagram can take the form of equipments connected in series, parallel, series-parallel, or a complex configuration. Alternate modes of operation can be considered in single functioned system models. The single functioned system Basic Reliability diagram can only be a series configuration in which any equipments provided for redundancy or alternate modes of operation for mission success are modeled in series. The conventional probability method makes use of the equations developed for redundancy to handle series, parallel, and series-parallel combinations of equipments. For non-series parallel or complex configurations, use or repeated use of the following equation is required.

$$P_S = P_S \text{ (if X is good)} R_X + P_S \text{ (if X is bad)} Q_X \quad (1)$$

Where  $P_S$  = reliability of mission

$P_S$  (if X is good) = reliability of mission if X is good

$P_S$  (if X is bad) = reliability of mission if X is bad

$R_X$  = reliability of X

$Q_X$  = unreliability of X =  $1 - R_X$

In other words, the reliability of the mission is equal to the reliability of the mission given a specific portion of the system works times the probability that a portion of the system will work plus the reliability of the mission given that a specific portion of the system fails times the probability that that portion fails.

The above formula can also be used to generate probability of success equations for series-parallel configurations.

Formulas for probability of success,  $P_S$ , for various system configurations are derived as follows for various success diagrams. Each formula shown can be used as a building block to evaluate a more complex success diagram.

## MIL-STD-756B

## 2.1.1 Series model.

2.1.1.1 If there is only one equipment in the system and it is required, then the Mission Reliability (and Basic Reliability) diagram is:



The probability of success for the system is obviously the probability of success of equipment A, or

$$P_S = P_A \quad (2)$$

The probability of A failing would be  $1 - P_A$

2.1.1.2 For a two equipment serial system the Mission Reliability (and Basic Reliability) diagram is:



$$P_S = P(\text{success with A working}) P_A + \\ P(\text{success with A failure}) P(A \text{ failing})$$

$$P_S = (P_B) (P_A) + (0) (1 - P_A) \quad (3)$$

$$P_S = P_A P_B \quad \text{if A and B are identical}$$

$$P_S = (P_A)^2 \quad (4)$$

2.1.1.3 For a three equipment serial system the Mission Reliability (and Basic Reliability) diagram is:



$$P_S = P(\text{success with A working}) P_A + \\ P(\text{success with A failed}) (1 - P_A)$$

$$P_S = (P_B P_C) P_A + 0 (1 - P_A)$$

Where  $P_B P_C$  is derived as in (3) above.

$$P_S = P_A P_B P_C$$



## 2.1.2 Parallel models.

2.1.2.1 For a two equipment active parallel system the Mission Reliability diagram is:

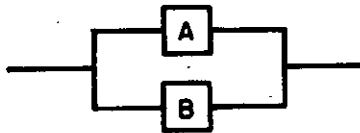

$$P_S = P(\text{mission success with A working}) P_A + P(\text{mission success with A failed}) (1 - P_A)$$

$$P_S = (1) P_A + P_B (1 - P_A)$$

$$P_S = P_A + P_B - P_A P_B \quad (6)$$

if A and B are identical

$$P_S = 2P_A - (P_A)^2 \quad (7)$$

The equivalent Basic Reliability mathematical model for this system is (3).

2.1.2.2 For a three equipment active parallel system the Mission Reliability diagram is:

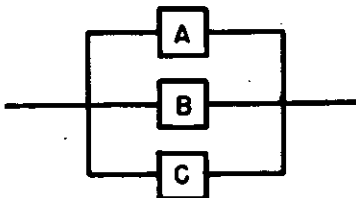

$$P_S = P_A + P_B + P_C - P_A P_B - P_A P_C - P_B P_C + P_A P_B P_C \quad (8)$$

if A, B, and C are identical

$$P_S = 3P_A - 3(P_A)^2 + (P_A)^3 \quad (9)$$

The equivalent Basic Reliability mathematical model for this system is (5).

## MIL-STD-756B

2.1.2.3 For a two equipment standby parallel system the Mission Reliability diagram is:



The switch, S, detects a failure of the operative element and instantaneously switches from the failed element to a standby element.

The switch may fail in two ways: (1) the switch may fail to operate when required,  $Q_1$  and (2) the switch may operate without command (i.e., prematurely),  $Q_2$ .

$$P_S = P(\text{mission success with A working}) P_A + \\ P(\text{mission success with A failed}) (1 - P_A)$$

$$P_S = P_2 P_A + (1 - P_2) P_B P_A + P_1 P_B (1 - P_A)$$

$$P_S = P_A P_B (1 - P_1 - P_2) + P_A P_2 + P_B P_1 \quad (10)$$

Where  $P_1$  = probability of no failure to switch when required

$P_2$  = probability of no premature switching.

The equivalent Basic Reliability mathematical model for this system is:

$$P_S = P_A P_B P_1 P_2$$

2.1.2.4 For a three element majority voting redundancy the Mission Reliability diagram is:

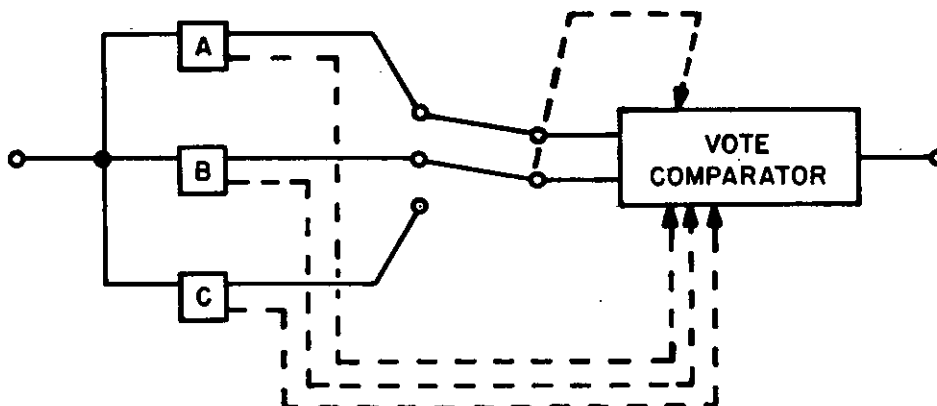

## MIL-STD-756B

In majority voting redundancy the proper output of the system is presumed to be the output of the majority of the individual elements which feed the vote comparator. The output is determined by the vote comparator, which decides what the majority of the elements indicates. In the three element case, at least two good elements are required for successful operation:

$$P_S = P_V (P_A P_B + P_A P_C + P_B P_C - 2 P_A P_B P_C) \quad (12)$$

Where  $P_V$  = reliability of the vote comparator.

The equivalent Basic Reliability mathematical model for this system is:

$$P_S = P_V P_A P_B P_C \quad (13)$$

### 2.1.3 Series-parallel models.

2.1.3.1 As one example of a complex series-parallel combination of equipments the Mission Reliability diagram is:

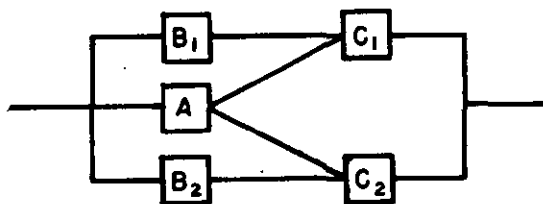

The system requirement would be that equipment A and either equipment  $C_1$  or  $C_2$  work, or that equipments  $B_1$  and  $C_1$  work, or that  $B_2$  and  $C_2$  work for success. Equipments with the same letter are identical, i.e.,  $C_1 = C_2$  and  $B_1 = B_2$ .

$$P_S = P(\text{mission success with A working}) P_A \\ + P(\text{mission success with A failed}) (1 - P_A) \\ P_S = (2P_C - P_C^2) P_A + [2P_B P_C - (P_B P_C)^2] (1 - P_A) \quad (14)$$

An example involving the above diagram follows:

Assuming

$$P_A = 0.3$$

$$P_{B_1} = P_{B_2} = 0.1$$

$$P_{C_1} = P_{C_2} = 0.2$$

## MIL-STD-756B

and therefore,

$$(1 - P_A) = 0.7$$

$$(1 - P_B) = 0.9$$

$$(1 - P_C) = 0.8$$

Evaluating the probability of success for a given mission as:

$$P_S = (.4 - .04) \cdot 3 + [.04 - .0004] (.7)$$

$$P_S = 0.13572$$

The equivalent Basic Reliability mathematical model for this system is:

$$P_S = P_A P_B^2 P_C^2$$

and the Basic Reliability is 0.00012.

2.1.3.2 The same procedure can be followed for any complex Mission Reliability diagram. As the Mission Reliability diagram becomes increasingly complex it could be broken down into parts as shown in the diagram below. Equipments with the same letter are identical.

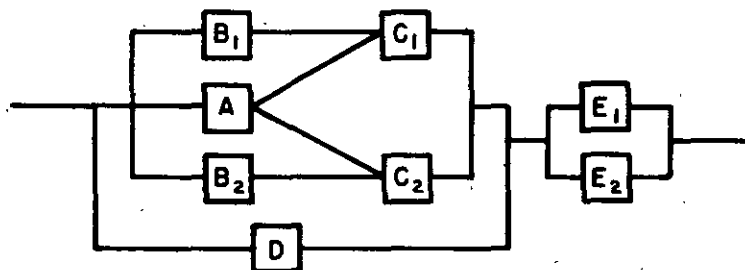

Reducing the mission success diagram using (14) and (7)

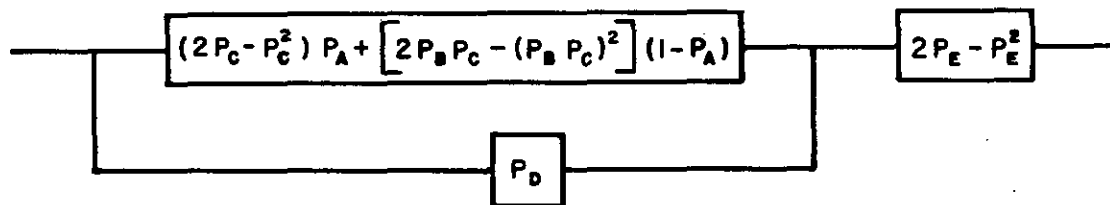

## MIL-STD-756B

And finally using 2.1.2.1 and 2.1.1.2 the equation becomes

$$P_S = \left[ (2P_C - P_C^2)P_A + [2P_B P_C - (P_B P_C)^2](1 - P_A) + P_D - P_D [(2P_C - P_C^2)P_A + \{2P_B P_C - (P_B P_C)^2\}(1 - P_A)] \right] (2P_E - P_E^2) \quad (16)$$

NOTE: This equation can be expanded and reduced.

The equivalent Basic Reliability mathematical model for this configuration is:

$$P_S = P_A P_B^2 P_C^2 P_D P_E^2 \quad (17)$$

2.1.3.3 A 2 out of 3 system Mission Reliability diagram is:

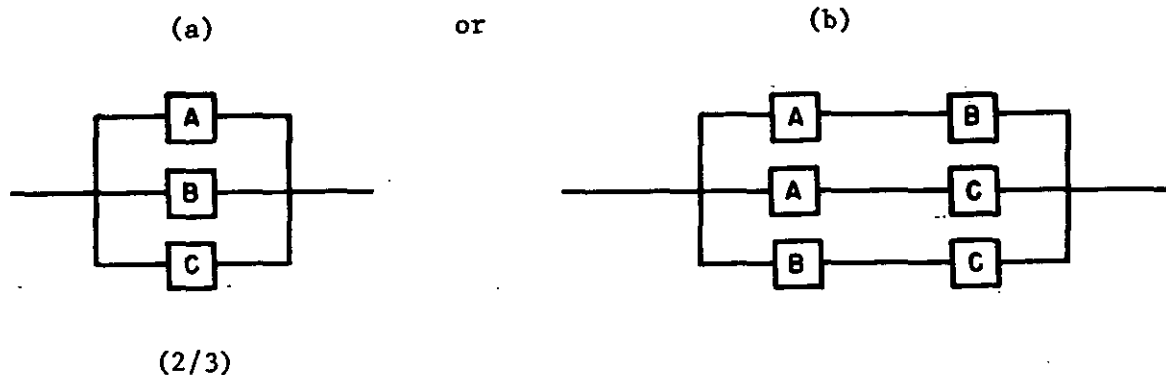

Using (3) and (6) the answer can be written directly from diagram (b)

$$P_S = P_A P_B + P_A P_C + P_B P_C - P_A P_B P_A P_C - P_A P_C P_B P_C - P_A P_B P_B P_C + P_A P_B P_A P_C P_B P_C \quad (18)$$

When the same equipment appears more than once in a diagram, the equations must be expanded into individual terms and all higher order factors must be reduced to single order factors before inserting equipment probabilities numbers into the equation. Thus,

$$P_A^2 = P_A, P_B^2 = P_B, \text{ and } P_C^2 = P_C$$

which results in

$$P_S = P_A P_B + P_A P_C + P_B P_C - 2P_A P_B P_C \quad (19)$$

The equivalent Basic Reliability mathematical model for this configuration is (5).

## MIL-STD-756B

2.1.3.4 Mixed series-parallel system Mission Reliability diagram is:

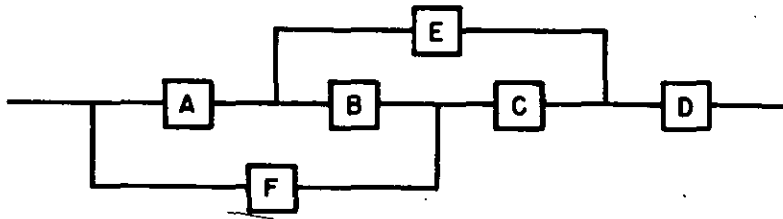

The example shows repeated use of the Mission Reliability formula.

$$P_S = P(\text{mission success with B working}) P_B + \\ P(\text{mission success with B failed}) (1 - P_B)$$

By selecting B and the X portion of the equation, the system does not reduce to a series parallel. (See 2.1 of Method 1001)

If B works Mission Reliability diagram reduces to:

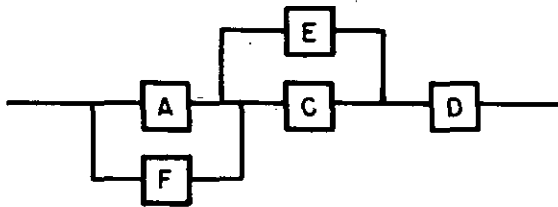

If B fails Mission Reliability diagram reduces to:

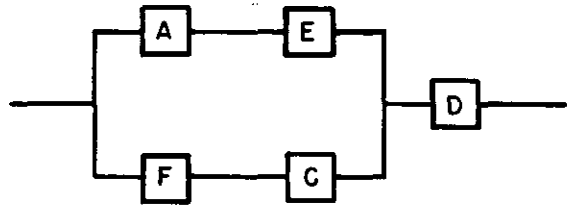

The first term of the Mission Reliability diagram has not been reduced to a series parallel configuration. Therefore, the process must be repeated as though this diagram were the new system.

$$P_S = P(\text{mission success with B working}) P_B + \\ [P_D (P_A P_E + P_F P_C - P_A P_E P_F P_C)] (1 - P_B)$$

$P(\text{mission success with B working}) = P(\text{success with B and C working}) P_C +$

$$P(\text{success with B working and C failed}) \\ (1 - P_C)$$

## MIL-STD-756B

$$P(\text{success with B working and C failed}) = P_A P_E P_D$$

$$P(\text{success with B and C working}) = (P_A + P_F - P_A P_F) P_D$$

$$\text{Substituting we get } P_S = \left[ (P_A + P_F - P_A P_F) P_D P_C + P_A P_D P_E (1 - P_C) \right] P_B + (P_A P_E + P_F P_C - P_A P_E P_F P_C) P_D (1 - P_B) \quad (20)$$

The equivalent Basic Reliability mathematical model for this system is:

$$P_S = P_A P_B P_C P_D P_E P_F \quad (21)$$

2.2 Multifunctioned systems. Multifunctioned systems can be treated similarly to single-functioned systems if one of the following applies:

- If no equipment appears in more than one function.
- If functions are time independent, i.e., they are either time sequenced functions or they are never used simultaneously.

If either (a) or (b) above applies, the procedure is as follows:

Treat each function separately as described under single functioned systems. For the system, the functions are treated as equipments and can be combined in series or parallel depending on the requirements. The resultant diagram is treated as a single functioned system. Each separate function can be compared with a reliability requirement for that function if desired.

When an equipment appears in several functions, the functions cannot be treated separately. The following example illustrates the point.

A system has two functions. The first function requires A or B for success and the second function requires B or C for success. Both functions are required for mission success. Mission Reliability diagrams for Function 1, Function 2, and the system are shown below.

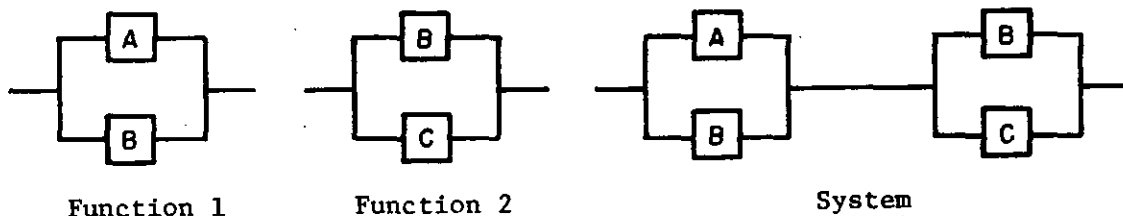

Assuming

$$P_A = 0.9$$

$$P_B = 0.8$$

$$P_C = 0.7$$

## MIL-STD-756B

Then the reliability of the function would be

$$\begin{aligned}\text{Function 1} &= 0.9 + 0.8 - (0.9)(0.8) \\ &= 0.98\end{aligned}$$

$$\begin{aligned}\text{Function 2} &= 0.8 + 0.7 - (0.8)(0.7) \\ &= 0.94\end{aligned}$$

Mission Reliability cannot be derived by multiplying function reliabilities because of the common element B.

$$\text{Mission Reliability} \neq (0.98)(0.94) = 0.9212$$

$$\begin{aligned}\text{Mission Reliability} &= P_B + P_A P_C - P_A P_B P_C \\ &= (0.8) + (0.9)(0.7) - (0.9)(0.8)(0.7) \quad (22) \\ &= 0.926\end{aligned}$$

The equivalent Basic Reliability mathematical model for this system is (5) and the Basic Reliability is 0.504.

### 2.2.1 Conventional probability method.

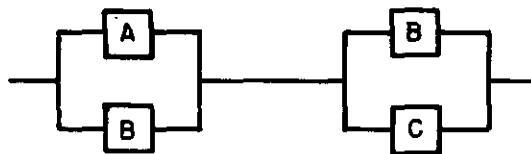

$P_S$  can be written directly

$$P_S = (P_A + P_B - P_A P_B) (P_B + P_C - P_B P_C) \quad (23)$$

This equation must be reduced before inserting the probabilities for the various equipments. This is the basic difference between using this method for single and multifunctioned systems.

Reduce the equation by multiplying terms

$$\begin{aligned}P_S &= P_A P_B + P_A P_C - P_A P_B P_C + P_B P_B + P_B P_C - P_B P_B P_C \quad (24) \\ &\quad - P_A P_B P_B - P_A P_B P_C + P_A P_B P_B P_C\end{aligned}$$

Where the same probability appears twice in a term delete one of the common factors.



## MIL-STD-756B

$$P_S = P_A P_B + P_A P_C - P_A P_B P_C + P_B + P_B P_C - P_B P_C \quad (25)$$

$$- P_A P_B - P_A P_B P_C + P_A P_B P_C$$

$$\text{simplifying } P_S = P_A P_C + P_B - P_A P_B P_C \quad (26)$$

The same result could be achieved using (1) as follows:

$$P_S = P(\text{mission success with B working}) P_B$$

$$+ P(\text{mission success with B failed}) (1 - P_B)$$

$$P_S = (1) P_B + P_A P_C (1 - P_B) \quad (27)$$

$$P_S = P_B + P_A P_C - P_A P_B P_C$$

## MIL-STD-756B

## METHOD 1002

## BOOLEAN TRUTH TABLE

1. **PURPOSE.** The purpose of the Boolean Truth Table method is to prepare a reliability mathematical model from a reliability block diagram by means of Boolean algebra. The Boolean Truth Table method is applicable to single functioned and multifunctioned systems. This method is more tedious than the conventional probability method but is useful when there is familiarity with Boolean algebra.

2. **PROCEDURE.**

2.1 Single functioned systems. Single functioned systems consist of equipments considered to have a single function associated with equipment performance. The single functioned system Mission Reliability diagram can take the form of equipments connected in series, parallel, series-parallel, or a complex configuration. Alternate modes of operation can be considered in single functioned system models. The single functioned system Basic Reliability diagram can only be a series configuration in which any equipments provided for redundancy or alternate modes of operation for mission success are modeled in series. The procedure for the Boolean Truth Table approach is illustrated by the following example. The Mission Reliability diagram is given as:

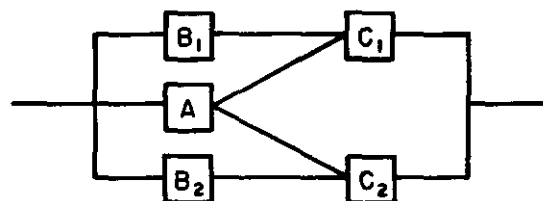

given:

$$P_A = 0.3$$

$$1 - P_A = 0.7$$

$$P_{B_1} = P_{B_2} = 0.1$$

and therefore

$$1 - P_B = 0.9$$

$$P_{C_1} = P_{C_2} = 0.2$$

$$1 - P_C = 0.8$$

The Boolean algebra approach lists all equipments in a truth table form (See Table 1002-I). The truth table has  $2^n$  entries where  $n$  is the number of equipments in the system. The table has a 1 or 0 entry in each column indicating success or failure respectively on each equipment. All possible combinations of all equipments working and failing are thus listed. The procedure is to examine each row of the truth table and decide whether the combination of equipments working and failed yields system success(S) or failure(F). Insert an S or F respectively in the next column in the table. For each S entry, multiply the respective probabilities for the indicated state of each equipment to yield a  $P_S$  for that entry.

## MIL-STD-756B

Entry number 4 is the entry with a success indicated and .03888 is obtained by multiplying

$$(1 - P_{B_1}) (1 - P_{B_2}) (1 - P_{C_1}) P_{C_2} P_A \quad \text{or}$$

$$(.9) (.9) (.8) (.2) (.3) = .03888$$

All figures in the  $P_S$  column are then added for a Mission Reliability probability or .13572 in this example.

The equivalent Basic Reliability mathematical model for this system is:

$$P_S = P_A P_{B_1} P_{B_2} P_{C_1} P_{C_2} \quad (1)$$

and the Basic Reliability probability is 0.00012.

Table 1002-I. Truth Table Calculation for the Mission Reliability Diagram.

Entry No.	$B_1$	$B_2$	$C_1$	$C_2$	A	Success or Failure	$P_S$
1	0	0	0	0	0	F	-
2	0	0	0	0	1	F	-
3	0	0	0	1	0	F	-
4	0	0	0	1	1	S	.03888
5	0	0	1	0	0	F	-
6	0	0	1	0	1	S	.03888
7	0	0	1	1	0	F	-
8	0	0	1	1	1	S	.00972
9	0	1	0	0	0	F	-
10	0	1	0	0	1	F	-
11	0	1	0	1	0	S	.01008
12	0	1	0	1	1	S	.00432
13	0	1	1	0	0	F	-
14	0	1	1	0	1	S	.00432
15	0	1	1	1	0	S	.00252
16	0	1	1	1	1	S	.00108
17	1	0	0	0	0	F	-
18	1	0	0	0	1	F	-
19	1	0	0	1	0	F	-
20	1	0	0	1	1	S	.00432
21	1	0	1	0	0	S	.01008
22	1	0	1	0	1	S	.00432
23	1	0	1	1	0	S	.00252
24	1	0	1	1	1	S	.00108
25	1	1	0	0	0	F	-
26	1	1	0	0	1	F	-
27	1	1	0	1	0	S	.00112
28	1	1	0	1	1	S	.00048
29	1	1	1	0	0	S	.00112
30	1	1	1	0	1	S	.00048
31	1	1	1	1	0	S	.00028
32	1	1	1	1	1	S	.00012

Σ All success paths = .13572

## MIL-STD-756B

2.1.1 Boolean algebra equation. A Mission Reliability equation can be written from the truth table (Table 1002-I) is desired. In this case it would look like the following:

$$\begin{aligned}
 P_S = & \bar{B}_1 \bar{B}_2 \bar{C}_1 C_2 A + \bar{B}_1 \bar{B}_2 C_1 \bar{C}_2 A + \bar{B}_1 \bar{B}_2 C_1 C_2 A + \bar{B}_1 B_2 \bar{C}_1 C_2 \bar{A} \\
 & + \bar{B}_1 B_2 \bar{C}_1 C_2 A + \bar{B}_1 B_2 C_1 \bar{C}_2 A + \bar{B}_1 B_2 C_1 C_2 \bar{A} + \bar{B}_1 B_2 C_1 C_2 A \\
 & + B_1 \bar{B}_2 \bar{C}_1 C_2 A + B_1 \bar{B}_2 C_1 \bar{C}_2 \bar{A} + B_1 \bar{B}_2 C_1 \bar{C}_2 A + B_1 \bar{B}_2 C_1 C_2 \bar{A} \\
 & + B_1 \bar{B}_2 C_1 C_2 A + B_1 B_2 \bar{C}_1 C_2 \bar{A} + B_1 B_2 \bar{C}_1 C_2 A + B_1 B_2 C_1 \bar{C}_2 \bar{A} \\
 & + B_1 B_2 C_1 \bar{C}_2 A + B_1 B_2 C_1 C_2 \bar{A} + B_1 B_2 C_1 C_2 A
 \end{aligned}$$

A bar above a letter indicates the complement or unreliability, e.g.,  $\bar{A} = (1 - A)$ .

With the aid of a reduction technique the nineteen terms of (2) can be reduced as follows:

- a. A reduction table (Table 1002-II) is constructed which allows the reduction of the 19 Boolean success terms to a simplified expression for the given Mission Reliability model. All 19 success paths are first listed in Column 1 of Table 1002-II. All letters represented by a zero (0) in Table 1002-I are indicated with a bar over the letter. This indicates unreliability. Any letter represented with a one (1) in Table 1002-I will be listed without a bar above it indicating reliability.
- b. By a comparative process, product pairs are formed for those terms in Column 1 of Table 1002-II which differ only by a letter inverse, thus forming a new product term which has this letter missing. For example, if Column 1 the two terms  $\bar{B}_1 \bar{B}_2 \bar{C}_1 C_2 A$  and  $\bar{B}_1 \bar{B}_2 C_1 C_2 A$  differ only in the letter  $C_1$  and therefore can be combined to form the product term  $A \bar{B}_1 \bar{B}_2 C_2$  entered in Column 2. Again, this process is repeated by comparing product terms in Column 2 which differ only by a letter inverse, thus forming a new product term which is then entered in Column 3. It should be noted that once a term is used in a comparison, it is eliminated from all further comparisons, thus ensuring that all remaining terms are still mutually exclusive. The order of terms selected for the comparison process in Table 1002-II is not a necessary consideration; the resulting disjoint group of Boolean terms can always be interpreted, on a one-for-one basis, as the simplified probability of success (reliability) expression. For the given model, the probability of Mission Reliability has been reduced to the following terms:

$$P_S = B_1 C_1 + \bar{B}_1 B_2 C_2 + A \bar{B}_1 \bar{B}_2 C_2 + A \bar{B}_1 C_1 \bar{C}_2 + B_1 B_2 \bar{C}_1 C_2 + B_1 \bar{B}_2 \bar{C}_1 C_2 A$$

MIL-STD-756B

Table 1002-II. Reduction Tabulation.

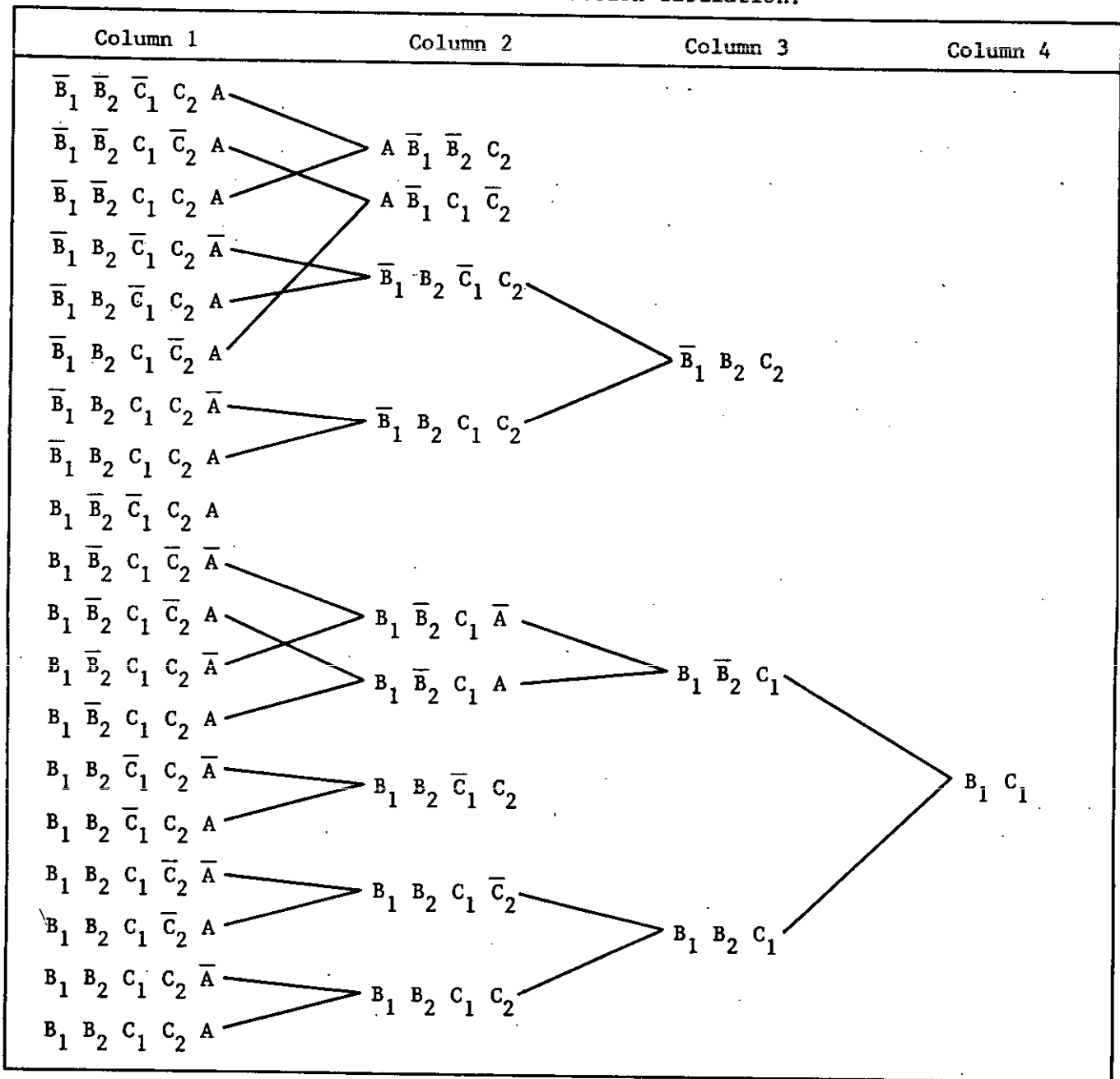

METHOD 1002  
18 November 1981

## MIL-STD-756B

- c. Substituting the reliabilities and unreliabilities used previously into (3), we obtain:

$$P_S = (.1) (.2) + (.9) (.1) (.2) + (.3) (.9) (.9) (.2) + (.3) (.9) (.2) (.8) + (.1) (.1) (.8) (.2) + (.1) (.9) (.8) (.2) (.3) = .13572 \text{ which is the same probability of success shown in the summation for Table 1002-I.}$$

2.2 Multifunctioned systems. Multifunctioned systems can be treated similarly to single functioned systems if one of the following applies:

- If no equipment appears in more than one function.
- If functions are time independent, i.e., they are either time sequenced functions or they are never used simultaneously.

If either (a) or (b) above applies, the procedure is as follows:

Treat each function separately as described under single functioned systems. For the system, the functions are treated as equipments and can be combined in series or parallel depending on the requirements. The resultant diagram is treated as a single functioned system. Each separate function can be compared with a reliability requirement for that function if desired.

When an equipment appears in several functions, the functions cannot be treated separately. The following example illustrates the point.

A system has two functions. The first function requires A or B for success and the second function requires B or C for success. Both functions are required for mission success. Mission Reliability diagrams for Function 1, Function 2, and the system are shown below:

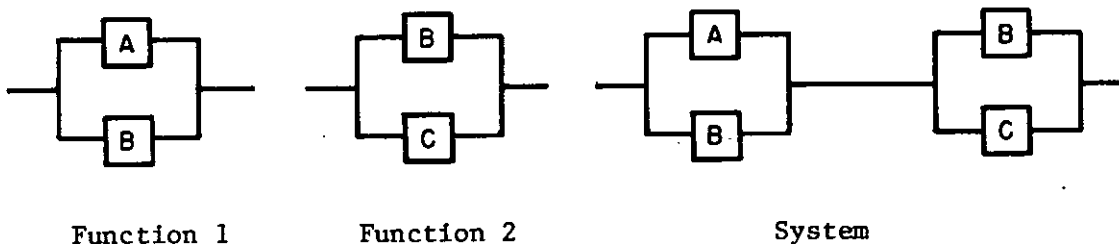

Assuming

$$P_A = 0.9$$

$$P_B = 0.8$$

$$P_C = 0.7$$

Then the reliability of the function would be

METHOD 1002  
18 November 1981

MIL-STD-756B

$$\begin{aligned} \text{Function 1} &= 0.9 + 0.8 - (0.9)(0.8) \\ &= 0.98 \end{aligned}$$

$$\begin{aligned} \text{Function 2} &= 0.8 + 0.7 - (0.8)(0.7) \\ &= 0.94 \end{aligned}$$

Mission Reliability cannot be derived by multiplying function reliabilities because of the common element B.

$$\text{Mission Reliability} \neq (0.98)(0.94) = 0.9212$$

$$\begin{aligned} \text{Mission Reliability} &= P_B + P_A P_C - P_A P_B P_C \\ &= (0.8) + (0.9)(0.7) - (0.9)(0.8)(0.7) \quad (4) \\ &= 0.926 \end{aligned}$$

The Boolean Truth Table solution is:

A	B	C	Success or Failure	P <sub>A</sub>
0	0	0	F	-
0	0	1	F	-
0	1	0	S	.024
0	1	1	S	.056
1	0	0	F	-
1	0	1	S	.126
1	1	0	S	.216
1	1	1	S	.504
TOTAL				.926

The equivalent Basic Reliability mathematical model for this system is:

$$P_S = P_A P_B P_C \quad (5)$$

The Basic Reliability is 0.504.

## MIL-STD-756B

## METHOD 1003

## LOGIC DIAGRAMS

1. **PURPOSE.** The purpose of the logic diagram method is to prepare a reliability mathematical model from a reliability block diagram by means of logic diagrams. The logic diagram method is applicable to single functioned and multifunctioned systems. This method is more tedious than the conventional probability method but is a short cut method for the Boolean truth table approach in combining terms to simplify the Mission Reliability equation.

2. **PROCEDURE.**

2.1 **Single functioned systems.** Single functioned systems consist of equipments considered to have a single function associated with equipment performance. The single functioned system Mission Reliability diagram can take the form of equipments connected in series, parallel, series-parallel, or a complex configuration. Alternate modes of operation can be considered in single functioned system models. The single functioned system Basic Reliability diagram can only be a series configuration in which any equipments provided for redundancy or alternate modes of operation for mission success are modeled in series. The logic diagram procedure is to translate the reliability block diagram into a switching network. A closed contact represents equipment success, an open contact equipment failure. Each complete path of contacts represents an alternate mode of operation. Each equipment that is required for each alternative mode of operation is identified by a contact along a path. All paths terminate at the same point (success). The logic diagram is developed so that all paths are mutually exclusive; by use of a few simple manipulations, the amount of effort involved over the Boolean truth table method can be shortened.

Logic diagrams for series, parallel, and series-parallel diagrams are easy to draw as shown in Table 1003-I.

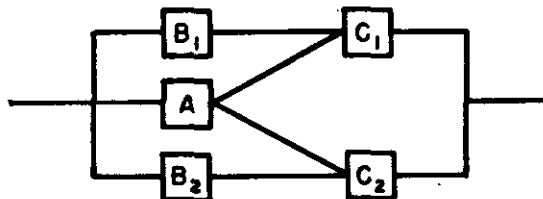

For complex configurations the procedure is to reduce the reliability diagram to a series-parallel configuration by successively splitting the diagram into subdiagrams by removing one equipment and replacing it with a short circuit and an open circuit. An example will clarify the procedure.





## MIL-STD-756B

Table 1003-I. Logic Diagram Examples

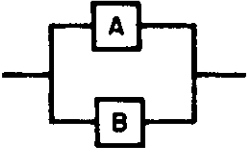
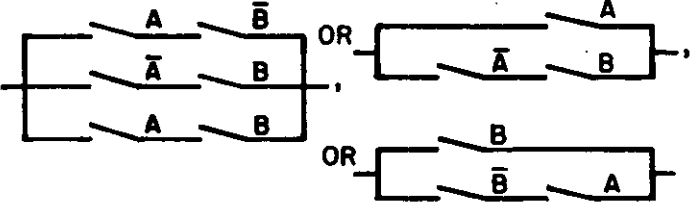
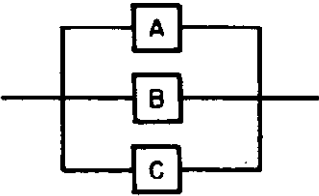
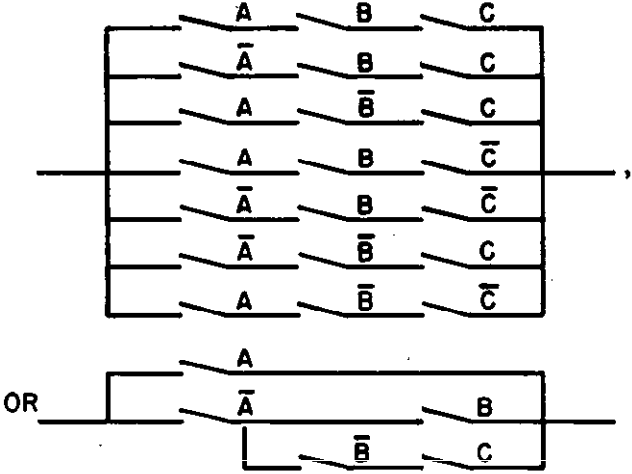
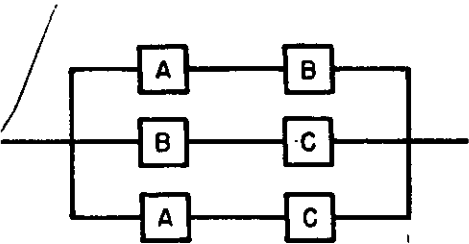
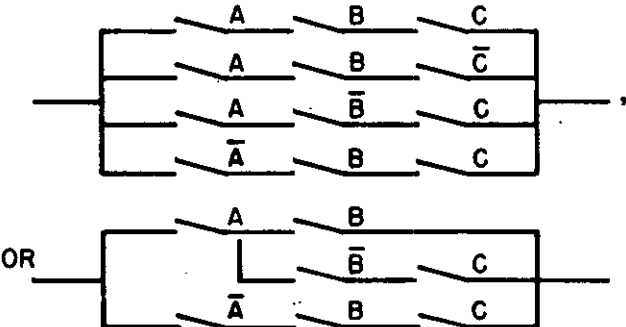
MISSION RELIABILITY DIAGRAM	LOGIC DIAGRAM
	
	
	
	
<p>OTHER SERIES PARALLEL COMBINATIONS CAN BE QUITE SIMPLY DRAWN.</p>	

NOTE: When one logic switch A is open, all must be open and all  $\bar{A}$  must be closed and similarly for B and C logic switches.

## MIL-STD-756B

Remove equipment A by splitting the diagram as follows:

(In the diagrams which follow, the term "short" indicates a circuit which is always operative; the term "open" indicates a circuit which is never operative).

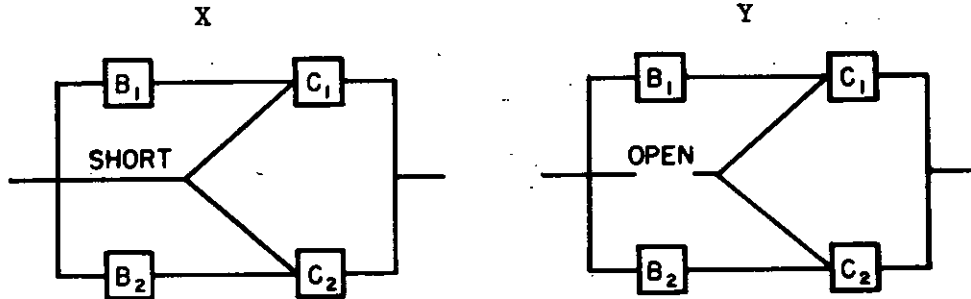

Now start the logic diagram

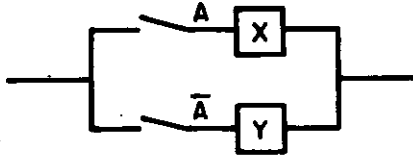

X and Y are now in series parallel form and can be drawn directly, therefore, the logic diagram would appear as follows:

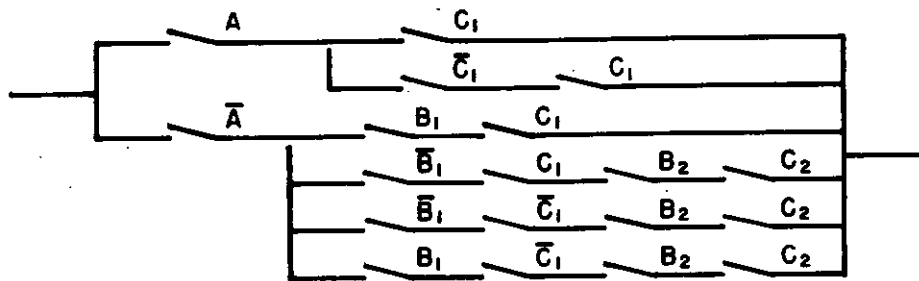

If removing one equipment by replacing it by an open and short circuit will not reduce the system to two series parallel diagrams, two equipments must be removed. The logic diagram would then look as follows:

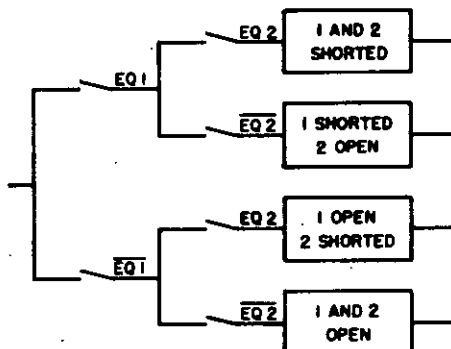

## MIL-STD-756B

After the logic diagram is drawn, two approaches are possible for a numerical answer. The first involves writing an equation for the probability of success,  $P_S$ , by writing down every path with an addition sign joining all paths. The second approach is to insert values for the various probabilities directly into the logic diagram and multiply series terms and add parallel terms until just one series term remains. This result is the answer. For the above example:

$$P_S = A [C_1 + \bar{C}_1 C_2] + \bar{A} [B_1 C_1 + \bar{B}_1 C_1 B_2 C_2 + \bar{B}_1 \bar{C}_1 B_2 C_2 + B_1 \bar{C}_1 B_2 C_2]$$

2.2 Multifunctioned systems. Multifunctioned systems can be treated similarly to single-functioned systems if one of the following applies:

- a. If no equipment appears in more than one function.
- b. If functions are time independent, i.e., they are either time sequenced functions or they are never used simultaneously.

If either (a) or (b) above applies, the procedure is as follows:

Treat each function separately as described under single functioned systems. For the system, the functions are treated as equipments and can be combined in series or parallel depending on the requirements. The resultant diagram is treated as a single functioned system. Each separate function can be compared with a reliability requirement for that function if desired.

When an equipment appears in several functions, the functions cannot be treated separately. The following example illustrates the point.

A system has two functions. The first function requires A or B for success and the second function requires B or C for success. Both functions are required for mission success. Mission Reliability diagrams for Function 1, Function 2, and the system are shown below.

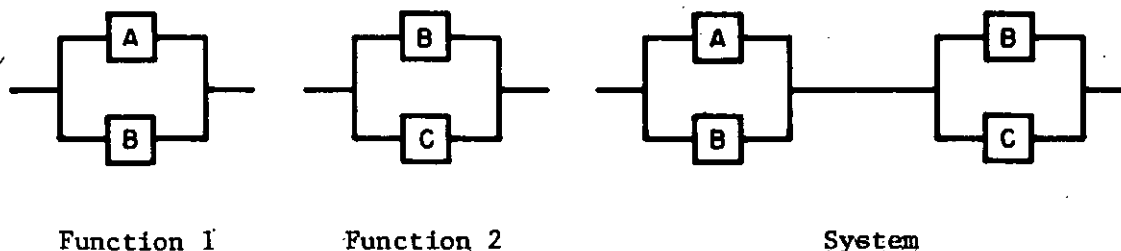

Assuming

$$P_A = 0.9$$

$$P_B = 0.8$$

$$P_C = 0.7$$

## MIL-STD-756B

Then the reliability of the function would be

$$\begin{aligned} \text{Function 1} &= 0.9 + 0.8 - (0.9)(0.8) \\ &= 0.98 \end{aligned}$$

$$\begin{aligned} \text{Function 2} &= 0.8 + 0.7 - (0.8)(0.7) \\ &= 0.94 \end{aligned}$$

Mission Reliability cannot be derived by multiplying function reliabilities because of the common element B.

$$\text{Mission Reliability} \neq (0.98)(0.94) = 0.9212$$

$$\begin{aligned} \text{Mission Reliability} &= P_B + P_A P_C - P_A P_B P_C \\ &= (0.8) + (0.9)(0.7) - (0.9)(0.8)(0.7) \\ &= 0.926 \end{aligned} \quad (2)$$

The equivalent Basic Reliability mathematical model for this system is:

$$P_S = P_A P_B P_C \quad (3)$$

and the Basic Reliability is 0.504.

2.2.1 Logic diagram method. The logic diagram would be as follows:

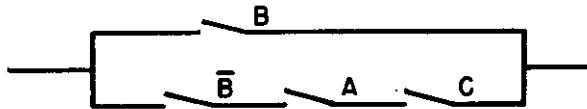

$$P_S = P_B + P_A \bar{P}_B P_C \quad (4)$$

$$P_S = 0.926$$

Using the logic diagram method, there must be no two similar items in any success path. This is the only difference for multiple functioned systems. If the system is a complex system and elements are taken out for conversion to a series-parallel system, an element must be shorted or opened every where it appears before reducing to a series parallel system.

## MIL-STD-756B

## METHOD 1004

## MONTE CARLO SIMULATION

1. **PURPOSE.** The purpose of the Monte Carlo simulation method is to synthesize a system reliability prediction from a reliability block diagram by means of random sampling. The Monte Carlo simulation method is employed in instances where individual equipment probabilities (or equivalent reliability parameter) are known but the mission reliability model is exceedingly complex to derive a general equation for solution. The Monte Carlo simulation method does not result in a general probability of success equation but computes the system probability of success from the individual equipment probabilities and the reliability block diagram. A Monte Carlo simulation can be performed manually but is invariably performed by computer due to the large number of repetitive trials and calculations required to obtain a significant result. The Monte Carlo simulation method is applicable to single functioned and multifunctioned systems.

2. **PROCEDURE.**

2.1 Single functioned systems. Single functioned systems consist of equipments considered to have a single function associated with equipment performance. The single functioned system Mission Reliability diagram can take the form of equipments connected in series, parallel, series-parallel, or a complex configuration. Alternate modes of operation can be considered in single functioned system models. The single functioned system Basic Reliability diagram can only be a series configuration in which any equipments provided for redundancy or alternate modes of operation for mission success are modeled in series.

The Monte Carlo simulation procedure is to determine the distribution of a function of one or more variables from the distribution of the individual variables. The method involves random sampling from the distributions of all variables and inserting the values so obtained in the equation for the function of interest. Suppose the function whose probability of success distribution is to be estimated is  $P(x_1, \dots, x_n)$  and that the  $X_1, X_2, \dots, X_n$  are independent random variables whose distributions are presumed to be known. The procedure is to pick a set of  $x$ 's randomly from the distributions of the  $X$ 's, calculate  $P$  for that set, and store that value of  $P$ . The procedure is repeated many times until enough values of  $P$  are obtained. From this sample of  $P$  values, its distribution and parameters can be estimated.

The Monte Carlo simulation method is based on several principles of probability and on the techniques of probability transformation. One of the underlying principles is the law of large numbers, which states that the larger the sample the more certainly the sample mean will be a good estimate of the population mean. The procedure for the Monte Carlo simulation method is illustrated by the following example. The Mission Reliability diagram is given as:

## MIL-STD-756B

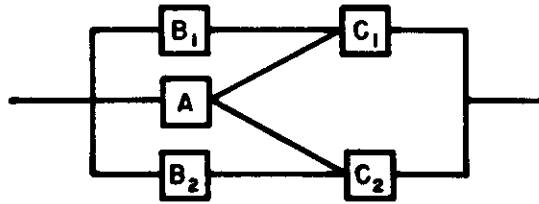

given:

$$P_A = 0.3$$

$$P_{B_1} = P_{B_2} = 0.1$$

$$P_{C_1} = P_{C_2} = 0.2$$

Select a random number between 0.01 and 1.00 from a table of random numbers or generated by a computer. Compare the random number with  $P_A$ . If the random number is equal to or less than 0.3 then equipment A is a success. Once success (S) or failure (F) is determined, it is recorded as in Table 1004-I and the procedure is repeated for equipments  $B_1$ ,  $B_2$ ,  $C_1$  and  $C_2$ . A new random number for each equipment is used to compare against that equipment and results are recorded. If a success path can be found among the failed and nonfailed equipments then the system function is determined to be a success.  $P_S$  is the ratio of system successes to trials.

Table 1004-I displays the outcome of ten trials of a typical Monte Carlo simulation. In this particular outcome, there was one system success for the ten trials (trial 8) resulting in  $P_S = 0.10$ . Depending upon the random numbers generated, the success/failure array may differ from simulation to simulation and the number of system successes may vary for any fixed number of trials. However, as the number of trials increase, the ratio of system successes to trials should approach the actual  $P_S$  of 0.13572. The degree of Monte Carlo precision is determined by the number of trials conducted. Typically, a minimum of 100 trials is required.

The equivalent Basic Reliability mathematical model for this system is:

$$P_S = P_A P_{B_1} P_{B_2} P_{C_1} P_{C_2} \quad (1)$$

and the Basic Reliability probability is 0.00012.

2.2 Multifunctioned systems. Multifunctioned systems can be treated similarly to single-functioned systems if one of the following applies:

- a. If no equipment appears in more than one function.
- b. If functions are time independent, i.e., they are either time sequenced functions or they are never used simultaneously.

## MIL-STD-756B

Table 1004-I. Success/Failure Array for the Mission Reliability Diagram.

<u>Trial No.</u>	<u>A</u>	<u>B<sub>1</sub></u>	<u>B<sub>2</sub></u>	<u>C<sub>1</sub></u>	<u>C<sub>2</sub></u>	<u>System</u>
1	S	F	S	F	F	F
2	F	F	F	F	S	F
3	S	F	F	F	F	F
4	F	F	F	F	F	F
5	S	F	F	F	F	F
6	F	F	F	F	F	F
7	F	F	F	F	S	F
8	S	F	S	F	S	S
9	F	F	F	F	F	F
10	F	S	F	F	F	F

$$\hat{P}_S = \frac{1}{10} = 0.10$$

NOTE: This is only one possible array and one possible outcome among many that can result from a Monte Carlo simulation of ten trials. Additional trials are required to obtain meaningful precision with which the Monte Carlo result will approximate the actual answer.

If either (a) or (b) applies, the procedure is as follows:

Treat each function separately as described under single functioned systems. For the system, the functions are treated as equipments and can be combined in series or parallel depending on the requirements. The resultant diagram is treated as a single functioned system. Each separate function can be compared with a reliability requirement for that function if desired.

When an equipment appears in several functions, the functions cannot be treated separately. The following example illustrates the point.

A system has two functions. The first function requires A or B for success and the second function requires B or C for success. Both functions are required for mission success. Mission Reliability diagrams for Function 1, Function 2, and the system are shown as follows.

## MIL-STD-756B

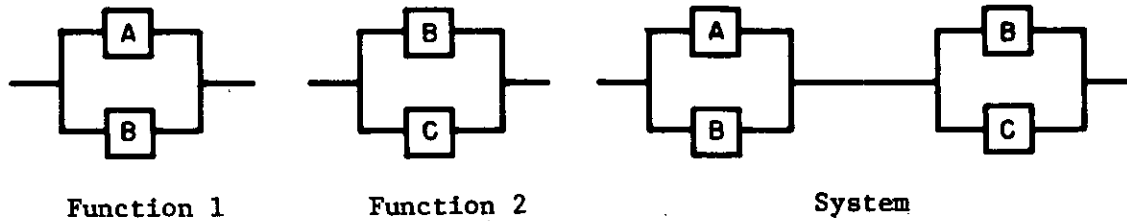

Assuming

$$P_A = 0.9$$

$$P_B = 0.8$$

$$P_C = 0.7$$

Then the reliability of the function would be

$$\begin{aligned} \text{Function 1} &= 0.9 + 0.8 - (0.9)(0.8) \\ &= 0.98 \end{aligned}$$

$$\begin{aligned} \text{Function 2} &= 0.8 + 0.7 - (0.8)(0.7) \\ &= 0.94 \end{aligned}$$

Mission Reliability cannot be derived by multiplying function reliabilities because of the common element B.

$$\text{Mission Reliability} \neq (0.98)(0.94) = 0.9212$$

$$\begin{aligned} \text{Mission Reliability} &= P_B + P_A P_C - P_A P_B P_C \\ &= (0.8) + (0.9)(0.7) - (0.9)(0.8)(0.7) \quad (2) \\ &= 0.926 \end{aligned}$$

The equivalent Basic Reliability mathematical model for this system is:

$$P_S = P_A P_B P_C \quad (3)$$

and the Basic Reliability is 0.504.

2.2.1 Monte Carlo simulation method. The Monte Carlo simulation solution based upon ten trials is shown in Table 1004-II. Additional trials are required to better approximate the actual answer of 0.926.



## MIL-STD-756B

Table 1004-II. Success/Failure Array for the Mission Reliability Diagram.

<u>Trial No.</u>	<u>A</u>	<u>B</u>	<u>C</u>	<u>System</u>
1	S	S	S	S
2	F	F	S	F
3	S	S	S	S
4	S	S	F	S
5	S	F	S	S
6	S	S	S	S
7	S	F	S	S
8	S	S	S	S
9	S	F	F	F
10	S	S	S	S

$$\hat{P}_S = \frac{8}{10} = 0.80$$

NOTE: This is only one possible array and one possible outcome among many that can result from a Monte Carlo simulation of ten trials. Additional trials are required to obtain meaningful precision with which the Monte Carlo result will approximate the actual answer.

## MIL-STD-756B

## METHOD 2001

## SIMILAR ITEM METHOD

1. PURPOSE. This prediction method utilizes specific experience on similar items. The most rapid way of estimating reliability is to compare the item under consideration with a similar item whose reliability has previously been determined by some means and has undergone field evaluation. This method has a continuing and meaningful application for items undergoing orderly evolution. Not only is the contemplated new design similar to the old design, but small differences can be easily isolated and evaluated. In addition, difficulties encountered in the old design are signposts to improvements in the new design. The similar circuit method should be considered if a similar item comparison cannot be made.

2. PROCEDURE.

2.1 Major factors for a direct comparison of similar items should include:

- a. Item physical and performance comparison
- b. Design similarity
- c. Manufacturing similarity
- d. Similarity of the service use profile (logistic, operational, and environmental)
- e. Program and project similarity
- f. Proof of reliability achievement

2.2 The validity of the similar item method is dependent upon the degree of equivalence between the items and not simply the generic term used to describe the items. For example, although both are power supplies (generic type), the achieved reliability of a ten watt power supply should not normally be used as a prediction method for a proposed one kilowatt power supply as the much higher power level of the proposed power supply may result in much lower reliability achievement due to design differences and stresses. A comparison may be made if there are scale factors to realistically relate reliability with item parameters such as power levels.

2.3 GIDEP Failure Rate Summaries are a data source for this method.

## MIL-STD-756B

## METHOD 2002

## SIMILAR CIRCUIT METHOD

1. PURPOSE. This prediction method utilizes specific experience on similar circuits such as oscillators, discriminator amplifiers, modulators, pulse transforming networks, etc. This method is employed either when only a circuit is being considered or the similar item method cannot be utilized. The most rapid way of estimating reliability is to compare the circuits of the item under consideration with similar circuits whose reliability has previously been determined by some means and has undergone field evaluation. Individual circuit reliabilities can be combined into an item reliability prediction. This method has a continuing and meaningful application for circuits undergoing orderly evolution. Not only is the contemplated new design similar to the old design, but small differences can be easily isolated and evaluated. In addition, difficulties encountered in the old design are signposts to improvements in the new design.

2. PROCEDURE

2.1 Major factors for a direct comparison of similar circuits should include:

- a. Circuit physical and performance comparison
- b. Design similarity
- c. Manufacturing similarity
- d. Similarity of the service use profile (logistic, operational, and environmental)
- e. Program and project similarity
- f. Proof of reliability achievement

2.2 Individual circuit reliabilities can be combined into an item reliability prediction. Circuit interconnect reliability factors should be considered when combining individual circuit reliabilities in order to determine a realistic item reliability prediction.

2.3 The validity of the similar circuit method is dependent upon the degree of equivalence between the circuits and not simply the generic term used to describe the items. For example, although both are amplifier circuits (generic term), the achieved reliability of a one milliwatt amplifier circuit should not normally be used as a prediction method for a proposed ten watt amplifier circuit as the much higher power level of the proposed amplifier circuit may result in much lower reliability achievement due to design differences and stresses. A comparison may be made if there are scale factors to realistically relate reliability with item parameters such as power levels.

MIL-STD-756B

2.4 Various equipment manufacturers and military agencies have preferred circuit manuals or documents with associated failure rates which may be utilized with this type prediction. GIDEP Failure Rate Summaries may be a data source for this method.

MIL-STD-756B

METHOD 2003

ACTIVE ELEMENT GROUP METHOD

1. PURPOSE. The Active Element Group (AEG) method is termed a feasibility estimating procedure because it is useful for gross estimates of a design in the concept formulation and preliminary design stages. Only an estimate of the number of series AEGs required to perform the design function is needed. The AEG method relates item functional complexity (active element groups) and application environment to failure rates experienced in fleet usage. Available data for this method is currently limited to ships and ships' missiles.

2. DOCUMENTS REFERENCED IN METHOD 2003:

PUBLICATIONS

Naval Sea Systems Command

NAVORD OD 44622 Reliability Data Analysis and Interpretation  
Volume 4

3. DEFINITIONS

3.1 Active element. A part that converts or controls energy; e.g., transistor, diode, electron tube, relay, valve, motor, hydraulic pump.

3.2 Active element group. An active element and its associated supporting (passive) parts; e.g., an amplifier circuit, a relay circuit, a pump and its plumbing and fittings.

3.3 Passive element. Any part, not itself an active element, used in conjunction with an active element to perform a desired function; e.g., capacitor, resistor, fitting.

4. PROCEDURE.

4.1 General considerations. In the AEG method enough is known about the design so that the number and types of active elements are known or can be estimates. Consideration must be given to the item reliability model in the application of AEG failure rates used to derive an item reliability prediction as AEGs may be utilized in redundant as alternate mode hardware configurations. The AEG method is based on several generalized assumptions which can be summarized as follows:

- a. All active elements can be defined and classified as representative types, and the quantity of supporting passive elements is effectively constant for each type, regardless of the end use item.

METHOD 2003  
18 November 1981

## MIL-STD-756B

- b. The inaccuracy inherent in assigning a single failure rate to each of the active element types is acceptable.
- c. A single failure rate can be used for each generic passive element type.
- d. The change in failure rate with environmental severity is identical for all part types.

The shaded areas in Figures 2003-1, 2003-2, and 2003-3 represent upper and lower failure rate bounds for the data upon which the figures were prepared.

4.2 Detailed Procedure. For each reliability block determine if the block's function is primarily analog, digital, or mechanical. Once the nature of the function is determined, proceed with one of the following steps.

4.2.1 Electronic Analog Function Failure Rate Estimation.

4.2.1.1 For each electronic analog reliability block, determine the number of series analog active elements necessary to perform the block's function. Use Table 2003-I to convert different classes of electronic AEGs to equivalent analog AEGs.

4.2.1.2 Determine the block's failure rate from Figure 2003-1 based upon the number of series equivalent analog AEGs and mission application.

Table 2003-I. Weighting Factors for Different Classes of Electronic AEGs Used in Estimating Analog Complexity for Figure 2003-1.

AEG Type	Analog Electronic AEGs
Analog signal functions:	
Transistor	1.0
Electron tube	1.0
Integrated circuit	1.0
Diode	0.1
Power supply functions:	
Transistor	2.0
Electron tube	2.0
Diode (rectifier)	1.0
Microwave power tube	100.0
Digital Functions:	
Transistor	0.1
Integrated circuit	0.1
Diode	0.01
Relays (general)	1.0

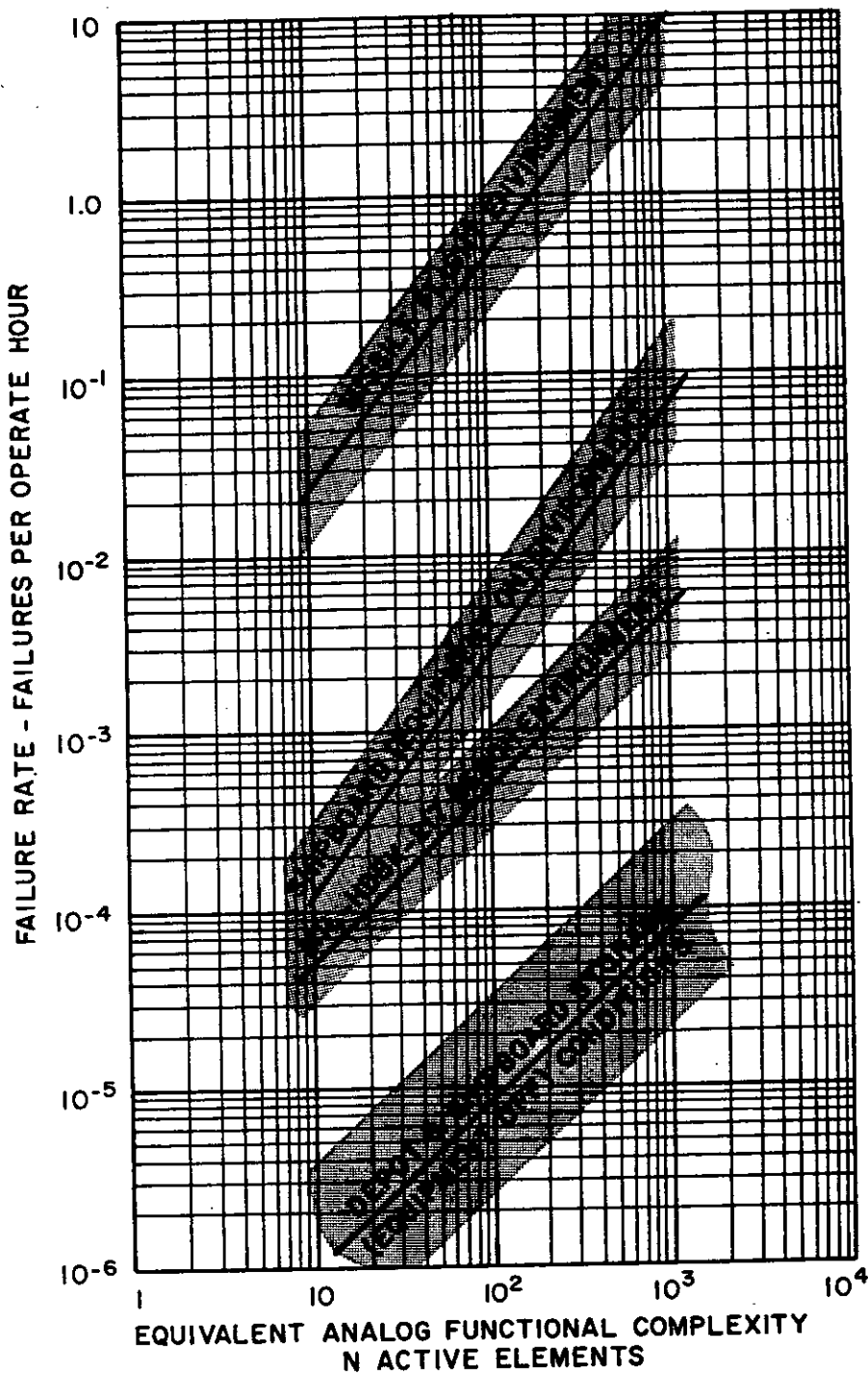

Figure 2003.1. Failure-Rate Estimating Chart for Electronic Analog Function.

## MIL-STD-756B

**4.2.2 Electronic Digital Function Failure Rate Estimation**

4.2.2.1 For each electronic digital reliability block, determine the number of series digital active elements necessary to perform the block's function. Use Table 2003-II to convert different classes of electronic AEGs to equivalent digital AEGs.

4.2.2.2 Determine the block's failure rate from Figure 2003-2 based upon the number of series equivalent digital AEGs and mission application.

**4.2.3 Mechanical Devices Function Failure Rate Estimation**

4.2.3.1 For each mechanical device reliability block, determine the number of series mechanical active elements necessary to perform the block's function. Use Table 2003-III to convert different classes of mechanical AEGs to equivalent analog AEGs.

4.2.3.2 Determine the block's failure rate from Figure 2003-3 based upon the number of series equivalent mechanical analog AEGs and mission application.

4.2.4 Reference. Additional details on the AEG method are provided in NAVORD OD 44622, Volume 4.



MIL-STD-756B

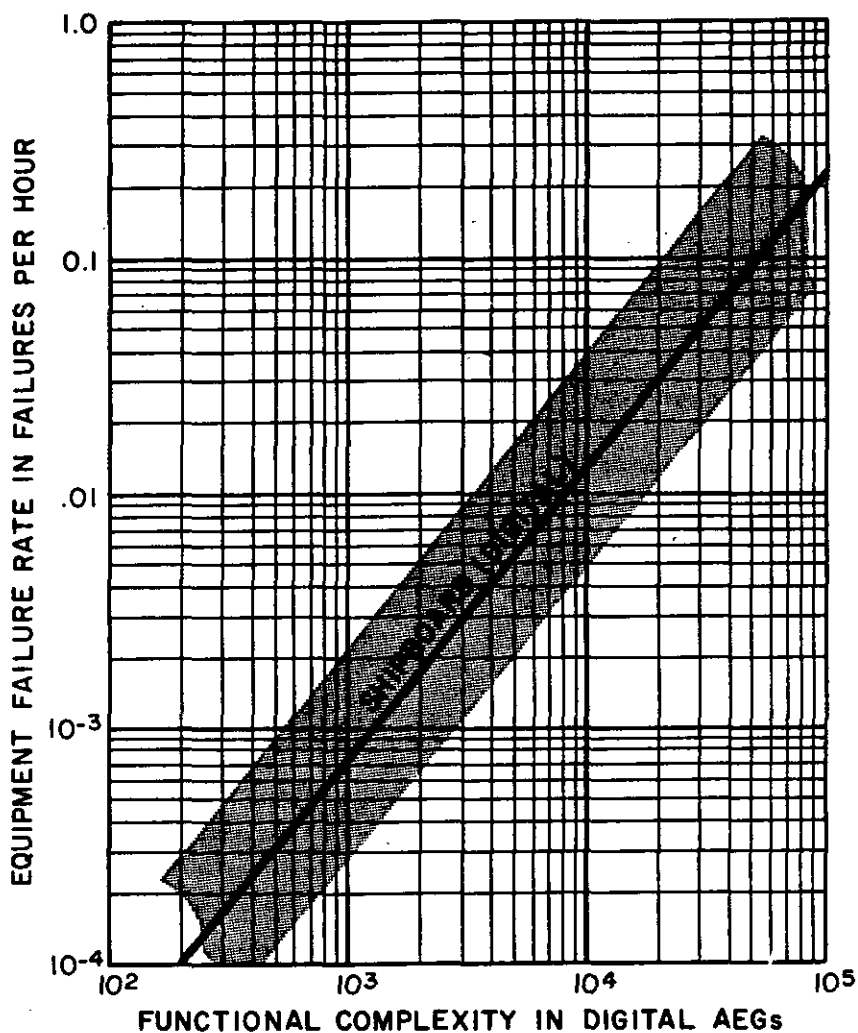

Figure 2003.2. Failure-Rate Estimation Chart for Digital Electronic Functions.

Table 2003-II. Weighting Factors for Estimating Digital Electronics AEG Complexity for Use With Figure 2003-2.

AEG Type	Digital Electronic AEGs
Transistor	1.0
Integrated circuit	1.0
Diode	0.1

## MIL-STD-756B

Table 2003-III. Weighting Factors for Shipboard  
Mechanical Elements for Use in Conjunction  
With Figure 2003-3.

AEG Type	Analog Mechanical AEGs
Actuator - hydraulic	2
Bearing	1
Clutch	1
Cylinder and piston - hydraulic, pneumatic	1
Gear train (per gear)	1
Governor - speed regulating	2
Gyro	3
Limiter - hydraulic flow	1
Link mechanism - mechanical drive	1
Motor - hydraulic, vacuum, turbo, pneumatic, electric	1
Pump - hydraulic, pneumatic, vacuum	1
Quick disconnect	1
Regulator - pneumatic, hydraulic, flow, pressure	1
Relay - thermal, pressure, electromechanical	1
Safety and arming device	4
Sensor - pressure, temperature	1
Switch - cam, interlock, pressure, thermal	1
Switch - sensitive, micro, etc.	2
Transducer - pressure, feedback	1
Valve - bleed, diaphragm, gate, needle, relief	1
Valve - servo	2

MIL-STD-756B

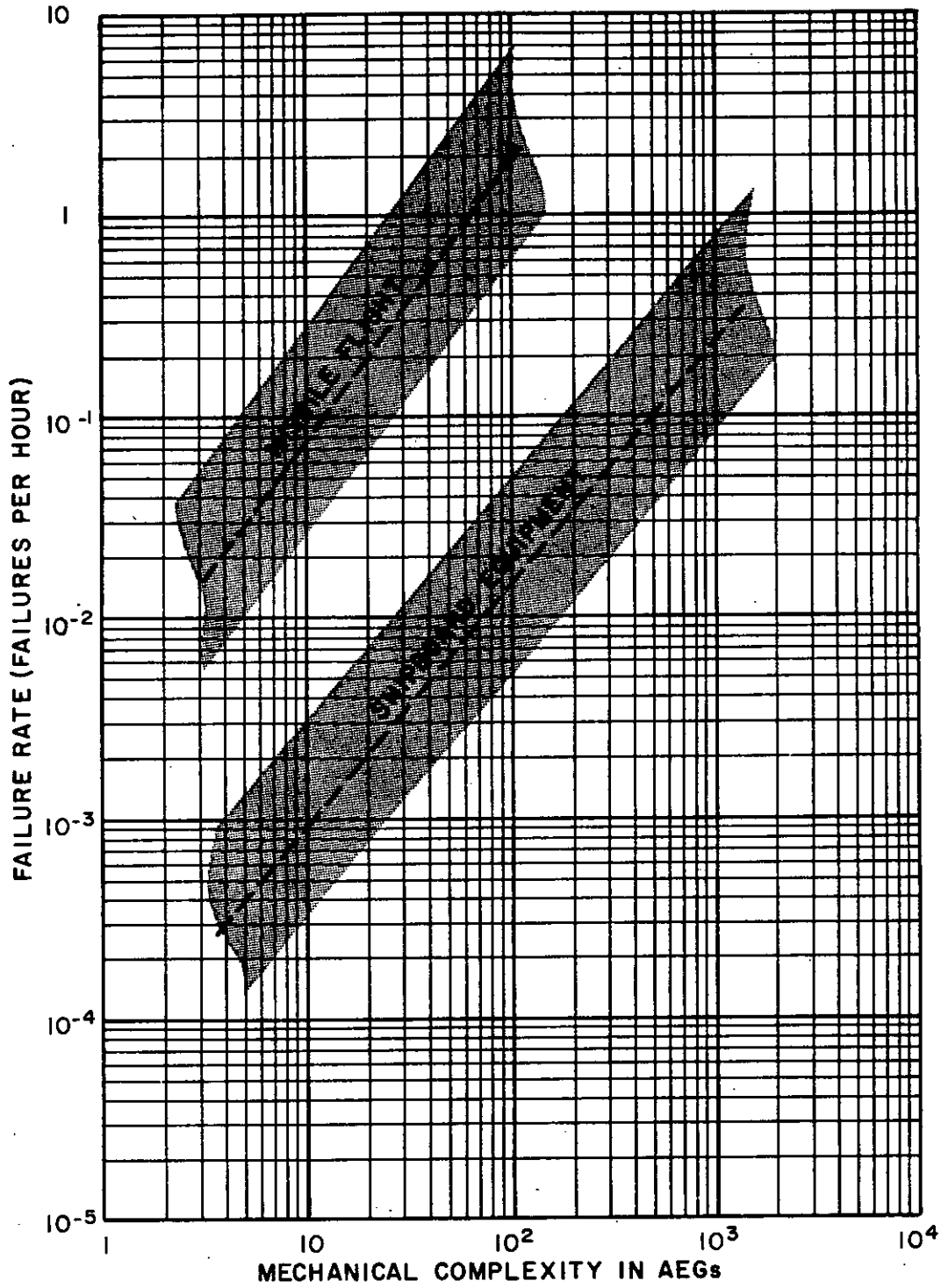

Figure 2003.3. Failure-Rate Estimation Chart for Mechanical Devices.

2003-7

METHOD 2003  
18 November 1981

## MIL-STD-756B

## METHOD 2004

## PARTS COUNT METHOD

1. PURPOSE. The parts count method is a prediction method used in the preliminary design stage when the number of parts in each generic type class such as capacitors, resistors, etc., are reasonably fixed and the overall design complexity is not expected to change appreciably during later stages of development and production. The parts count method assumes the time to failure of the parts is exponentially distributed (i.e., a constant failure rate).

2. DOCUMENTS REFERENCED IN METHOD 2004:

## HANDBOOKS

Military

MIL-HDBK-217 Reliability Prediction of Electronic Equipment

## OTHER PUBLICATIONS

RADC-TR-73-248 Dormancy and Power On-Off Cycling Effects on Electronic Equipment and Part Reliability

RADC-TR-74-269 Effects of Dormancy on Nonelectronic Components and Materials

LC-78-1 Storage Reliability of Missile Material Program, Missile Material Reliability Handbook Parts Count Prediction

GIDEP Government Industry Data Exchange Program, Summaries of Failure Rates

NPRD-1 Nonelectronic Parts Reliability Data, 1978

3. PROCEDURE.

3.1 The item failure rate can be determined directly by the summation of part failure rates if all elements of the item reliability model are in series or can be assumed in series for purposes of an approximation. In the event the item reliability model consists of non-series elements (e.g., redundancies, alternate modes of operation), item reliability can be determined either by considering only the series elements of the model as an approximation or by summing part failure rates for the individual elements and calculating an equivalent series failure rate for the non-series elements of the model.

## MIL-STD-756B

3.2 The information needed to support the parts count method includes:

- a. Generic part types (including complexity for microelectronics),
- b. part quantity,
- c. part quality levels (when known or can be assumed), and
- d. item environment.

3.3 The general expression for item failure rate with this method is:

$$\lambda_{\text{ITEM}} = \sum_{i=1}^{i=n} N_i (\lambda_G \pi_Q)_i$$

for a given item environment where:

$\lambda_{\text{ITEM}}$  = total failure rate

$\lambda_{G_i}$  = generic failure rate for the  $i^{\text{th}}$  generic part

$\pi_{Q_i}$  = quality factor for the  $i^{\text{th}}$  generic part

$N_i$  = quantity of  $i^{\text{th}}$  generic part

$n$  = number of different generic part categories

Equation (1) applies to an entire item being used in one environment. If the item comprises several units operating in different environments (such as avionics with units in airborne, inhabited, fighter (A<sub>IF</sub>) and uninhabited, fighter (A<sub>UF</sub>) environment), then equation (1) should be applied to the portions of the item in each environment. These "environment-item" failure rates should be added to determine total item failure rate.

3.4 Quality factors are to be applied to each part type where quality level data exists or can be reasonably assumed. Multi-quality levels and data exist for parts, such as microelectronics, discrete semiconductors, and for established reliability (ER) resistors and capacitors. For other parts such as nonelectronics,  $\pi_Q = 1$  providing that parts are procured in accordance with applicable parts specifications.

3.5 Failure rate data sources such as MIL-HDBK-217, NPRD-1, GIDEP, RADC-TR-73-248, RADC-TR-74-269 and LC-78-1 should be used with this method. However, GIDEP should only be used if the part of interest is not included in the other stated failure rate sources. Other failure rate data sources, including contractor in-house data, shall require procuring activity approval.

## MIL-STD-756B

## METHOD 2005

## PARTS STRESS ANALYSIS METHOD

1. PURPOSE. The parts stress analysis method is a prediction method used in the detailed design stage when there are few or no assumptions necessary about the parts used, their stress derating, their quality factors, their operating stresses or their environment in order to determine part failure rates. These should be all known factors or capable of being determined based upon the state of hardware definition for which the parts stress analysis method is applicable. Where unique parts are used, any assumptions regarding their failure rate factors should be identified and justified. The parts stress analysis method is the most accurate method of reliability prediction prior to measurement of reliability under actual or simulated use conditions. The parts stress analysis method assumes the time to failure of the parts is exponentially distributed (i.e., a constant failure rate).

2. DOCUMENTS REFERENCED IN METHOD 2005.

## HANDBOOKS

Military

MIL-HDBK-217 Reliability Prediction of Electronic Equipment

## OTHER PUBLICATIONS

RADC-TR-73-248 Dormancy and Power On-Off Cycling Effects on Electronic Equipment and Part Reliability

RADC-TR-74-269 Effects of Dormancy on Nonelectronic Components and Materials

LC-78-1 Storage Reliability of Missile Material Program, Missile Material Reliability Handbook Parts Count Prediction.

GIDEP Government Industry Data Exchange Program, Summaries of Failure Rates

NPRD-1 Nonelectronic Parts Reliability Data, 1978

## MIL-STD-756B

## 3. PROCEDURE

3.1 The item failure rate can be determined directly by the summation of part failure rates if all elements of the item reliability model are in series or can be assumed in series for purposes of an approximation. In the event the item reliability model consists of non-series elements (e.g., redundancies, alternate modes of operation), item reliability can be determined either by considering only the series elements of the model as an approximation or by summing part failure rates for the individual elements and calculating an equivalent series failure rate for the non-series elements of the model.

3.2 The information needed to support the parts stress analysis method included:

- a. Specific part types (including complexity for microelectronics),
- b. part quantity,
- c. part quality levels,
- d. item environment, and
- e. part operating stresses.

3.3 The general expression for item failure rate with this method is:

$$\lambda_{\text{ITEM}} = \sum_{i=1}^{i=n} N_i (\lambda_S \pi_Q)_i$$

for a given item environment where:

$\lambda_{\text{ITEM}}$  = total failure rate

$\lambda_{S_i}$  = specific failure rate for the  $i^{\text{th}}$  specific part

$\pi_{Q_i}$  = quality factor for the  $i^{\text{th}}$  specific part

$N_i$  = quantity of  $i^{\text{th}}$  specific part

$n$  = number of different specific part categories

## MIL-STD-756B

Equation (1) applies to an entire item being used in one environment. If the item comprises several units operating in different environments (such as avionics with units in airborne, inhabited, fighter ( $A_{IF}$ ) and uninhabited, fighter ( $A_{UF}$ ) environment), then equation (1) should be applied to the portions of the item in each environment. These "environment-item" failure rates should be added to determine total item failure rate.

3.4 Quality factors are to be applied to each part type where quality level data exists or can be reasonably assumed. Multi-quality levels and data exist for parts, such as microelectronics, discrete semiconductors, and for established reliability (ER) resistors and capacitors. For other parts such as nonelectronics,  $\pi_Q = 1$  providing that parts are procured in accordance with applicable parts specifications.

3.5 Failure rate data sources such as MIL-HDBK-217, NRPD-1, GIDEP, RADC-TR-73-248, RADC-TR-74-269 and LC-78-1 should be used with this method. However, GIDEP should only be used if the part of interest is not included in the other stated failure rate sources. Other failure rate data sources, including contractor in-house data, shall require procuring activity approval.



## MIL-STD-756B

## APPENDIX A

## Application and Tailoring Guide

## 10. GENERAL

10.1 Scope. This appendix provides notes for the guidance of the procuring activity in generating the contractual requirements for reliability modeling and a reliability prediction.

10.2 Tailoring requirements. Each provision of this standard should be reviewed to determine the extent of applicability. Tailoring of requirements may take the form of deletion, addition, or alteration to the statements in sections 3, 4, and 5 and any specified tasks or methods to adapt the requirements to specific item characteristics, procuring activity options, contractual structure, or acquisition phase. Due to the number of possible reliability modeling and reliability prediction methods, methods other than those identified in this standard may and should be used if another method is more suitable for the evaluation of the specific item and is cost effective in its implementation. The tailored reliability modeling and prediction requirements are specified in the contractual provisions to include input to the statement of work, contract data requirements list (CDRL), and other contractual means. The depth and detail of the reliability modeling and prediction effort will be defined in appropriate contractual and other program documentation.

10.3 Duplication of effort. A review of the contractual requirements is necessary to avoid duplication of effort between the reliability program and other program efforts such as maintainability, human engineering, safety, survivability, vulnerability, and integrated logistics support. Identification of the coincident generation of reliability modeling and prediction tasks or use of such tasks by the reliability program and other disciplinary areas is required in the reliability plan or other appropriate program documentation to avoid duplication of effort by the procuring activity and the contractor.

10.4 Limitations. Reliability modeling and prediction is only as accurate as the assumptions and data sources used in its preparation, and to the extent all pertinent influences are considered. The primary value of the reliability prediction is as a design tool for comparison of alternative approaches. Although the absolute value of item reliability derived by the prediction may be used in the deviation of expected field use reliability, it must be used with great caution and with full disclosure of the data sources and assumptions used. As an example, when field experience data for similar items in a like environment are utilized, the prediction reflects anticipated field performance after design maturity has been achieved. Conversely, when laboratory data are utilized, the prediction reflects expected performance under laboratory conditions.

20. REFERENCED DOCUMENTS (not applicable)

30. DEFINITIONS (not applicable)

## 40. GENERAL

40.1 Ordering data. The procuring activity shall specify information as indicated in the "Details to be specified" following each Task Section.

40.2 Data item descriptions. Data items generated in accordance with this standard are not deliverable unless specified on the Contract Data Requirements List (DD Form 1423) or the contract schedule. Format and content requirements shall be as specified by the procuring activity and in accordance with one of the following data requirements.

<u>Source</u>	<u>Data Requirements</u>	
Paragraph 4.9 and Task Section 100	Reliability Block Diagrams and Mathematical Models Report	DI-R-7094
Paragraph 4.9 and Task Section 200	Reliability Prediction and Documentation of Supporting Data	DI-R-7095
Paragraph 4.9	Reliability Report for Exploratory Advanced Development Model	DI-R-7100

## 50. APPLICATION CRITERIA

50.1 General considerations. This standard has been structured to facilitate the tailoring of reliability modeling and prediction requirements based upon individual program needs. Program variables such as item complexity, funding, and schedule influence the level of detail and timing of the reliability modeling and prediction effort and must be considered when tailoring the requirements. Not all programs require the same level of detail and the level of detail will also vary depending on the acquisition phase.

50.1.1 Level of detail. The level of detail applies to the level of indenture for which failure rate data can be applied. The reliability modeling and prediction effort can be accomplished at various levels of indenture from system to part level depending upon the information available and the needs of the program. The lower the indenture level, the greater the level of detail since more elements of the item will be considered. The choice of the level of indenture must be compatible with the program cost, schedule constraints and the item reliability requirements. A less detailed model and prediction which is available in time to contribute to item reliability is more valuable than a more detailed effort which is late and makes changes costly or unfeasible.

50.1.2 Timing. The objective of the reliability modeling and prediction effort is to support the decision making process in establishing numerical reliability requirements, assessing the adequacy of a design in meeting numerical requirements, and as a basis for selection among design alternatives. If the effort fails to provide usable information at or before a project decision point, then it has made no contribution and is untimely. The

## MIL-STD-756B

time-phasing of the reliability modeling and prediction effort is of paramount importance and should be identified in appropriate contractual and program documentation. Since program cost and schedule constraints require that available resources be used where they are most cost effective, the earliest possible availability of reliability modeling and prediction results is important so that the impact on cost and schedule be minimized.

50.1.3 Intended use. Reliability modeling and prediction is a beneficial and productive task in a well structured reliability program. Reliability modeling and prediction serves to help verify design integrity, identify and quantify sources of undesirable failure frequency, and document the reliability risks. Reliability modeling and prediction results can be used to provide the rationale for design changes to either improve item reliability or decrease item cost with little or no effect on item reliability. The reliability modeling and prediction results are not only used to provide design guidance, but they are used advantageously in and for maintenance planning analysis, logistics support analysis, survivability and vulnerability assessments, safety and hazards analyses, and for fault detection and isolation design. This coincident use of reliability modeling and prediction must be considered in program planning and every endeavor made to prevent duplication of effort by the program elements which utilize reliability modeling and prediction results.

**INSTRUCTIONS:** In a continuing effort to make our standardization documents better, the DoD provides this form for use in submitting comments and suggestions for improvements. All users of military standardization documents are invited to provide suggestions. This form may be detached, folded along the lines indicated, taped along the loose edge (*DO NOT STAPLE*), and mailed. In block 5, be as specific as possible about particular problem areas such as wording which required interpretation, was too rigid, restrictive, loose, ambiguous, or was incompatible, and give proposed wording changes which would alleviate the problems. Enter in block 6 any remarks not related to a specific paragraph of the document. If block 7 is filled out, an acknowledgement will be mailed to you within 30 days to let you know that your comments were received and are being considered.

**NOTE:** This form may not be used to request copies of documents, nor to request waivers, deviations, or clarification of specification requirements on current contracts. Comments submitted on this form do not constitute or imply authorization to waive any portion of the referenced document(s) or to amend contractual requirements.

(Fold along this line)

(Fold along this line)

DEPARTMENT OF THE NAVY  
Commanding Officer  
Naval Air Engineering Center  
Systems Engineering Standardization Department  
(SESD), Code 93  
Lakehurst, NJ 08733

OFFICIAL BUSINESS  
PENALTY FOR PRIVATE USE \$300



NO POSTAGE  
NECESSARY  
IF MAILED  
IN THE  
UNITED STATES

**BUSINESS REPLY MAIL**  
FIRST CLASS PERMIT NO. 12503 WASHINGTON D. C.

POSTAGE WILL BE PAID BY THE DEPARTMENT OF THE NAVY

Commanding Officer  
Naval Air Engineering Center  
Systems Engineering Standardization Department  
(SESD). Code 93  
Lakehurst, NJ 08733

ATTN: TJM (9322)



**STANDARDIZATION DOCUMENT IMPROVEMENT PROPOSAL***(See Instructions – Reverse Side)*

1. DOCUMENT NUMBER

2. DOCUMENT TITLE

3a. NAME OF SUBMITTING ORGANIZATION

4. TYPE OF ORGANIZATION *(Mark one)* VENDOR USER MANUFACTURER OTHER *(Specify):* \_\_\_\_\_b. ADDRESS *(Street, City, State, ZIP Code)***5. PROBLEM AREAS**

a. Paragraph Number and Wording:

b. Recommended Wording:

c. Reason/Rationale for Recommendation:

**6. REMARKS**7a. NAME OF SUBMITTER *(Last, First, MI) – Optional*b. WORK TELEPHONE NUMBER *(Include Area Code) – Optional*c. MAILING ADDRESS *(Street, City, State, ZIP Code) – Optional*8. DATE OF SUBMISSION *(YYMMDD)*