

NOTE: The cover page of this standard has been changed for administrative reasons. There are no changes to this document.

NOTICE OF  
CHANGE

**MIL-STD-348A**  
**20 April 1988**  
**SUPERSEDING**  
**MIL-STD-348**  
**25 MAR 1986**

**DEPARTMENT OF DEFENSE**  
**INTERFACE STANDARD**

**RADIO FREQUENCY CONNECTOR INTERFACES FOR**

**MIL-C-3643, MIL-C-3650, MIL-C-3655, MIL-C-25516,**  
**MIL-C-26637, MIL-C-39012, MIL-C-49142,**  
**MIL-A-55339, MIL-C-83517**



AMSC N/A

FSC 5935

DISTRIBUTION STATEMENT A. Approved for public release; distribution is unlimited.

MIL-STD-348A

DEPARTMENT OF DEFENSE  
WASHINGTON, DC 20402

Radio Frequency Connector Interfaces

1. This military standard is approved for use by all Departments and Agencies of the Department of Defense.

2. Beneficial comments (recommendations, additions, deletions) and any pertinent data which may be of use in improving this document should be addressed to: US Army Communications-Electronics Command, ATTN: AMSEL-ED-TD, Fort Monmouth, NJ 07703-5016, by using the self-addressed Standardization Document Improvement Proposal (DD Form 1426) appearing at the end of this document or by letter.

## MIL-STD-348A

## CONTENTS

	<u>Page</u>
1.	SCOPE - - - - - 1
1.1	Purpose - - - - - 1
1.2	Scope - - - - - 1
2.	REFERENCED DOCUMENTS- - - - - 2
2.1	Government documents- - - - - 2
2.1.1	Specification, and standard - - - - - 2
2.2	Order of precedence - - - - - 2
3.	DEFINITIONS - - - - - 3
3.1	Terms - - - - - 3
4.	GENERAL REQUIREMENTS- - - - - 4
5.	DETAILED REQUIREMENTS - - - - - 5
5.1	Gauge tests - - - - - 5
5.2	Marking - - - - - 5
5.3	Drawing notes - - - - - 5
6.	NOTES - - - - - 6
6.1	Subject term (key word) listing - - - - - 6
6.2	Changes from previous issue - - - - - 6

## FIGURES

Figure

101-1.	Interface, series TWTNC, coupling nut - - - - -	101.1
101-2.	Interface, series TWTNC, no coupling nut- - - - -	101.2
102-1.	Interface, series TWBNC, with coupling nut- - - - -	102.1
102-2.	Interface, series TWBNC, coupling nut - - - - -	102.2
102-3.	Interface, series TWBNC, without coupling nut - - - - -	102.3
103-1.	Interface, series TWSMC, with coupling nut- - - - -	103.1
103-2.	Interface, series TWSMC, without coupling nut - - - - -	103.2
104-1.	Interface, series TWSMB, with coupling mechanism- - - - -	104.1
104-2.	Interface, series TWSMB, without coupling mechanism - - - - -	104.2
201-1.	Interface, series TRB, pin contact- - - - -	201.1
201-2.	Interface, series TRB, socket contact - - - - -	201.2
202-1.	Interface, series TRT, pin contact- - - - -	202.1
202-2.	Interface, series TRT, socket contact - - - - -	202.2
301-1.	Interface, series BNC, pin contact- - - - -	301.1
301-2.	Interface, series BNC, socket contact - - - - -	301.2
302-1.	Interface, series C, pin contact- - - - -	302.1
302-2.	Interface, series C, socket contact - - - - -	302.2
303-1.	Interface, series MHV, pin contact- - - - -	303.1
303-2.	Interface, series MHV, socket contact - - - - -	303.2
304-1.	Interface, series N, pin contact- - - - -	304.1
304-2.	Interface, series N, socket contact - - - - -	304.2
305-1.	Interface, series QL, pin contact - - - - -	305.1
305-2.	Interface, series QL, socket contact- - - - -	305.2
306-1.	Interface, series QM, pin contact - - - - -	306.1
306-2.	Interface, series QM, socket contact- - - - -	306.2
307-1.	Interface, series QNC, pin contact- - - - -	307.1
307-2.	Interface, series QNC, socket contact - - - - -	307.2
308-1.	Interface, series QSC, pin contact- - - - -	308.1
308-2.	Interface, series QSC, socket contact - - - - -	308.2
309-1.	Interface, series SC, pin contact - - - - -	309.1
309-2.	Interface, series SC, socket contact- - - - -	309.2
310-1.	Interface, series SMA, pin contact- - - - -	310.1
310-2.	Interface, series SMA, socket contact - - - - -	310.2

## MIL-STD-348A

## CONTENTS - Continued

	<u>Page</u>
310-3. Interface, series SMA, no contact - - - - -	310.3
311-1. Interface, series SMB, pin contact - - - - -	311.1
311-2. Interface, series SMB, socket contact - - - - -	311.2
312-1. Interface, series SMC, pin contact - - - - -	312.1
312-2. Interface, series SMC, socket contact - - - - -	312.2
313-1. Interface, series TNC, pin contact - - - - -	313.1
313-2. Interface, series TNC, socket contact - - - - -	313.2
314-1. Interface, series SHV, pin contact - - - - -	314.1
314-2. Interface, series SHV, socket contact - - - - -	314.2
315-1. Interface, series LC, pin contact - - - - -	315.1
315-2. Interface, series LC, socket contact - - - - -	315.2
315-3. Interface, series LC, pin contact - - - - -	315.3
315-4. Interface, series LC, socket contact - - - - -	315.4
315-5. Interface, series LC, pin contact - - - - -	315.5
315-6. Interface, series LC, socket contact - - - - -	315.6
316-1. Interface, coaxial environment resistant - - - - -	316.1
316-2. Interface, coaxial environment resistant - - - - -	316.2
316-3. Interface, coaxial environment resistant - - - - -	316.3
316-4. Interface, coaxial environment resistant - - - - -	316.4
317-1. Interface, series HN, pin contact - - - - -	317.1
317-2. Interface, series HN, socket contact - - - - -	317.2
318-1. Interface, series LT, no contact - - - - -	318.1
318-2. Interface, series LT, socket contact - - - - -	318.2
319-1. Interface, series SSMA, pin contact - - - - -	319.1
319-2. Interface, series SSMA, socket contact - - - - -	319.2
401-1. Interface, test connector, series C, pin contact - - - - -	401.1
401-2. Interface, test connector, series C, socket contact - - - - -	401.2
401-3. Interface, mated test connector, series C - - - - -	401.3
402-1. Interface, test connector, series N, pin contact - - - - -	402.1
402-2. Interface, test connector, series N, socket contact - - - - -	402.2
402-3. Interface, mated test connector, series N - - - - -	402.3
403-1. Interface, test connector, series SC, pin contact - - - - -	403.1
403-2. Interface, test connector, series SC, socket contact - - - - -	403.2
403-3. Interface, mated test connector, series SC - - - - -	403.3
404-1. Interface, test connector, series BNC, pin contact - - - - -	404.1
404-2. Interface, test connector, series BNC, socket contact - - - - -	404.2
404-3. Interface, mated test connector, series BNC - - - - -	404.3
405-1. Interface, series SMA, pin contact - - - - -	405.1
405-2. Interface, test connector, series SMA, socket contact - - - - -	405.2
405-3. Interface, mated test connector, series SMA - - - - -	405.3
406-1. Interface, test connector, series TNC, pin contact - - - - -	406.1
406-2. Interface, test connector, series TNC, socket contact - - - - -	406.2
406-3. Interface, mated test connector, series TNC - - - - -	406.3
407-1. Interface, test connector, series SMB, pin contact - - - - -	407.1
407-2. Interface, test connector, series SMB, socket contact - - - - -	407.2
407-3. Interface, mated test connector, series SMB - - - - -	407.3
408-1. Interface, test connector, series SMC, pin contact - - - - -	408.1
408-2. Interface, test connector, series SMC, socket contact - - - - -	408.2
408-3. Interface, mated test connector, series SMC - - - - -	408.3
409-1. Interface, test connector, series QNC, pin contact - - - - -	409.1
409-2. Interface, test connector, series QNC, socket contact - - - - -	409.2
409-3. Gap of mated standard test connector, series QNC - - - - -	409.3
410-1. Interface, test connector, series QSC, pin contact - - - - -	410.1
410-2. Interface, test connector, series QSC, socket contact - - - - -	410.2
410-3. Gap of mated standard test connector, series QSC - - - - -	410.3

MIL-STD-348A

1. SCOPE

1.1 Purpose. The purpose of this standard is to standardize radio frequency connector interfaces and to ensure the inclusion of essential design requirements.

1.2 Scope. This standard specifies the dimensional requirements for radio frequency connector interfaces referenced in MIL-C-3643, MIL-C-3650, MIL-C-3655, MIL-C-25516, MIL-C-26637, MIL-C-39012, MIL-C-49142, MIL-A-55339, and MIL-C-83517.

## MIL-STD-348A

## 2. REFERENCED DOCUMENTS

2.1 Government documents.

2.1.1 Specifications and standard. The following specifications and standard form a part of this standard to the extent specified herein. Unless otherwise specified, the issues of these documents shall be those listed in the issue of the Department of Defense Index of Specifications and Standards (DODISS) and supplement thereto, cited in the solicitation.

## SPECIFICATIONS

## MILITARY

- MIL-C-3643 - Connectors, Coaxial, Radio Frequency, Series HN, and Associated Fittings, General Specification For.
- MIL-C-3650 - Connectors, Coaxial, Radio Frequency, Series LC.
- MIL-C-3655 - Connectors, Plug and Receptacle, Electrical (Coaxial, Series Twin), and Associated Fittings, General Specification For.
- MIL-C-25516 - Connectors, Electrical, Miniature, Coaxial, Environment Resistant Type, General Specification For.
- MIL-C-26637 - Connectors, Coaxial, Radio Frequency Series LT, General Specification For.
- MIL-C-39012 - Connectors, Coaxial, Radio Frequency; General Specification For.
- MIL-C-49142 - Connector, Triaxial, Radio Frequency, General Specification For.
- MIL-A-55339 - Adapters, Connector, Coaxial, Radio Frequency, (Between Series and Within Series), General Specification For.
- MIL-C-83517 - Connector, Coaxial, Radio Frequency For Coaxial, Strip or Microstrip Transmission Line.

## STANDARD

## MILITARY

- MIL-STD-1373 - Screw-Thread, Modified, 60 Degree Stub, Double.

(Copies of the specifications and standard, required by contractors in connection with specific acquisition functions should be obtained from the contracting activity or as directed by the contracting activity.)

2.2 Order of precedence. In the event of a conflict between the text of this standard and the references cited herein, the text of this standard shall take precedence.

**MIL-STD-348A**

**3. DEFINITIONS**

**3.1 Terms.** The terms used in this standard are generally accepted by the electrical and electronics industries and commonly used in electrical connector engineering practice.

MIL-STD-348A

4. GENERAL REQUIREMENTS Not applicable



## MIL-STD-348A

## 5. DETAILED REQUIREMENTS

5.1 Gauge tests. Applicable gauge tests shall be as specified in the associated connector specification sheet.

5.2 Marking. Not applicable.

5.3 Drawing notes. Unless otherwise specified, the following information is applicable to all figures of this military standard.

- a. Dimensions are in inches.
- b. Metric equivalents are given for general information only.
- c. All undimensioned, pictorial configurations are for reference purposes only.
- d. Applicable to section 400 only. The construction, material, and finish of the standard socket connector shall result in satisfactory electrical and mechanical performance and provide the following minimum life cycles when mated with the same series pin standard test connector.

<u>Series</u>	<u>Life cycles</u>
C, N, SC, TNC	10,000
BNC	5,000
SMA, SMB, SMC	2,000

- e. Applicable to section 400 only. Dimensions shown are for the standard test connector only.

MIL-STD-348A

6. NOTES

6.1 Subject term (key word) listing.

Connector interfaces  
Connector, radio frequency  
Interfaces, radio frequency connector

6.2 Changes from previous issue. Asterisks are not used in this revision to identify changes with respect to the previous issue due to the extensiveness of the changes.

MIL-STD-348A

Custodians:

Army - CR  
Navy - EC  
Air Force - 85

Review activities:

Army - AT, AV, MI  
Navy - AS, SH  
Air Force - 10, 11, 17, 99  
DLA - ES

User activities:

Navy - CG, MC  
Air Force - 11

Preparing activity:  
Army - CR

Agent:  
DLA - ES

(Project 5935-3555)

**MIL-STD-348A**

**SECTION 100**

**Interface Dimensions for MIL-C-3655**

<b>Section 101</b>	<b>Series TWTNC</b>
<b>Section 102</b>	<b>Series TWBNC</b>
<b>Section 103</b>	<b>Series TWSMC</b>
<b>Section 104</b>	<b>Series TWSMB</b>

MIL-STD-348A

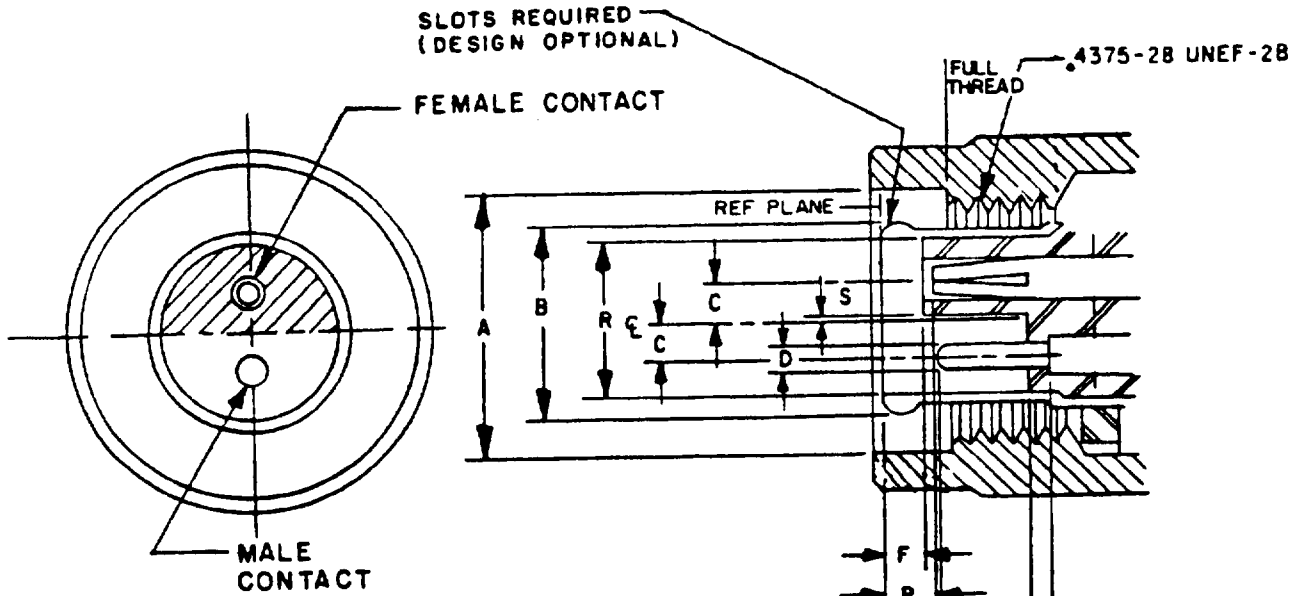

Dim Ltr	Inches		Millimeters	
	Min	Max	Min	Max
A	.440	-	11.18	-
B	Mating	test		
C	.062	.064	1.57	1.63
D	.037	.039	0.94	0.99
E	.228	.260	5.79	6.60
F	.028	.042	0.71	1.07
G	.206	.228	5.23	5.79
J	.035	.065	0.89	1.65
P	.032	.062	0.81	1.57
R	.264	-	6.71	-
S	.001	.004	0.03	0.10

Inches	mm
.010	0.25
.015	0.38
.037	0.94
.039	0.99
.061	1.55
.064	1.63
.180	4.57
.4375	11.112

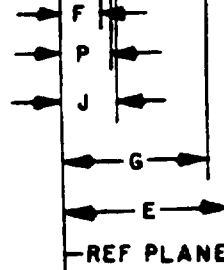

DIM TO MEET MATING TEST AND DURABILITY

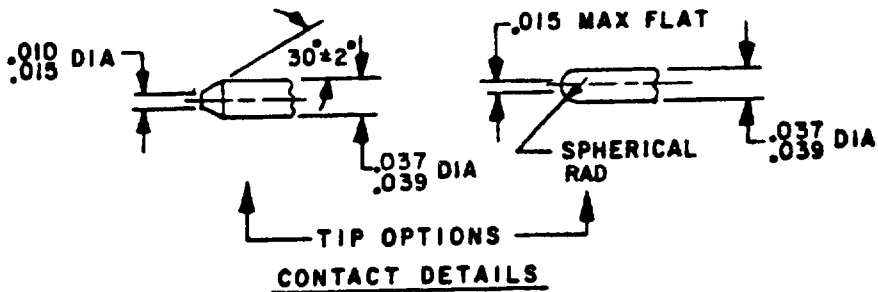
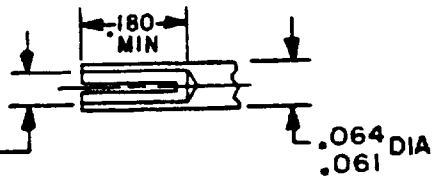

NOTES:

1. Three holes equally spaced, .027 (0.69 mm) minimum diameter for safety wiring. Location on coupling nut optional.
2. This interface shall meet the gauge requirements as specified in MIL-C-3655/14.

FIGURE 101-1. Interface, series TWNC, coupling nut.

MIL-STD-348A

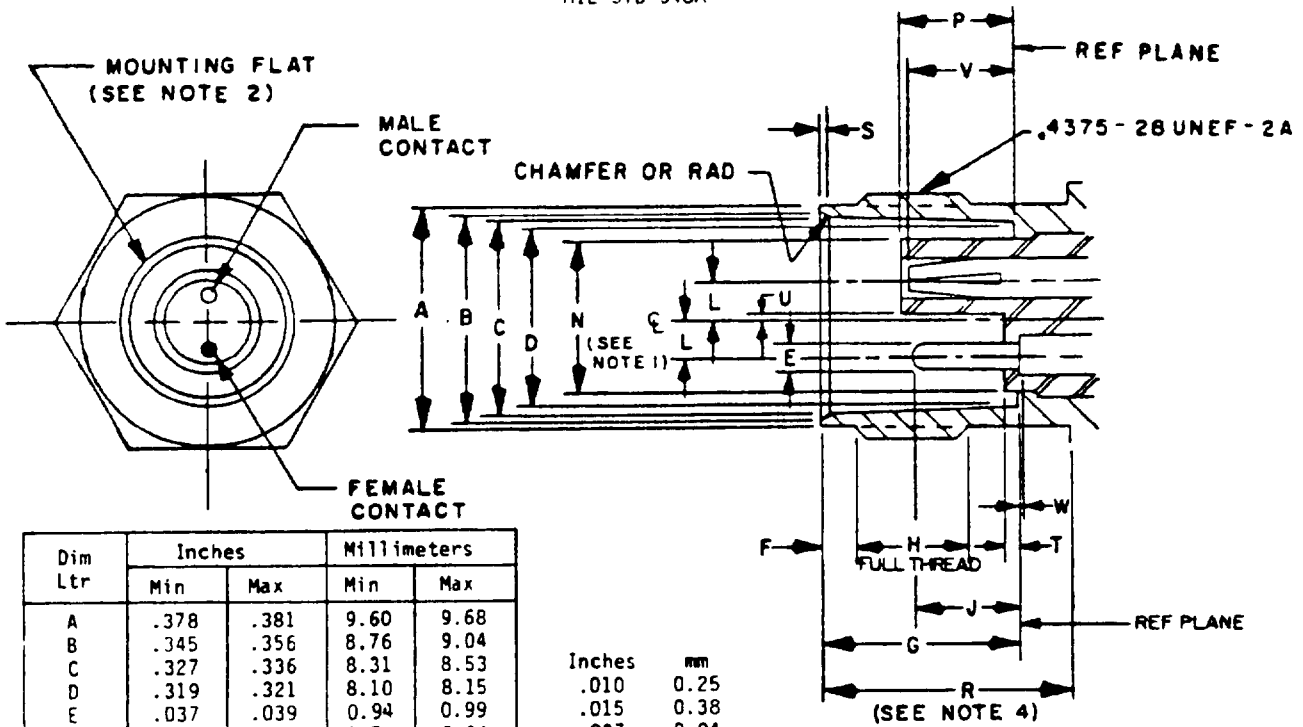

Inches	mm
.010	0.25
.015	0.38
.037	0.94
.039	0.99
.061	1.55
.064	1.63
.180	4.57
.4375	11.112

DIM TO MEET MATING TEST AND DURABILITY

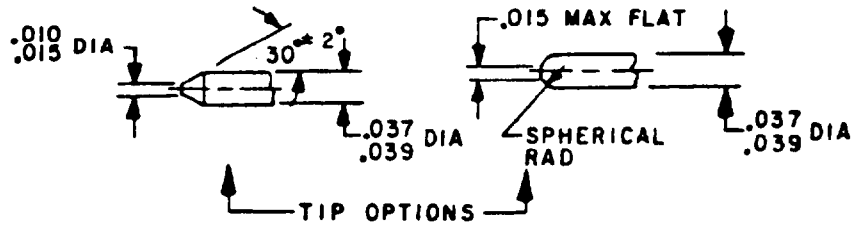
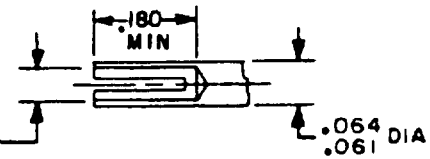

**CONTACT DETAILS**

**NOTES:**

1. N dimension applies to portion of dielectric protruding beyond reference plane.
2. Contacts, insulator, and mounting flat shall be oriented within  $\pm 3^\circ$  of orientation shown.
3. This interface shall meet the gauge requirements as specified in MIL-C-3655/13.
4. Clearance for mating connector coupling nut.

FIGURE 101-2. Interface, series TWNC, no coupling nut.

MIL-STD-348A

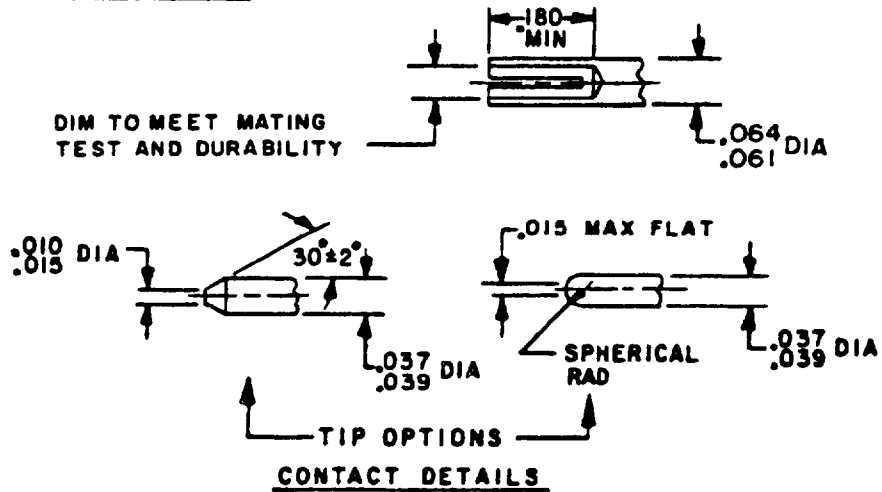
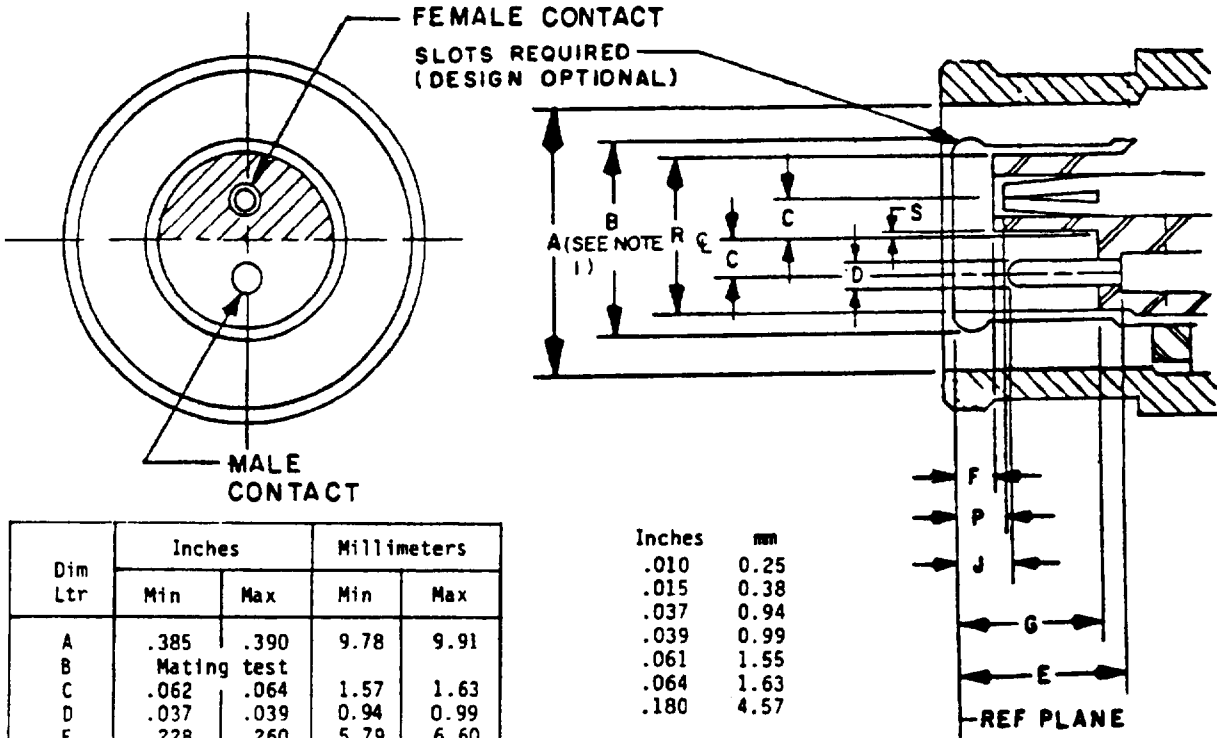

NOTES:

1. Flare to meet gauge test.
2. This interface shall meet the gauge requirements as specified in MIL-C-3655/15.

FIGURE 102-1. Interface, series TWBNC, with coupling nut.

MIL-STD-348A

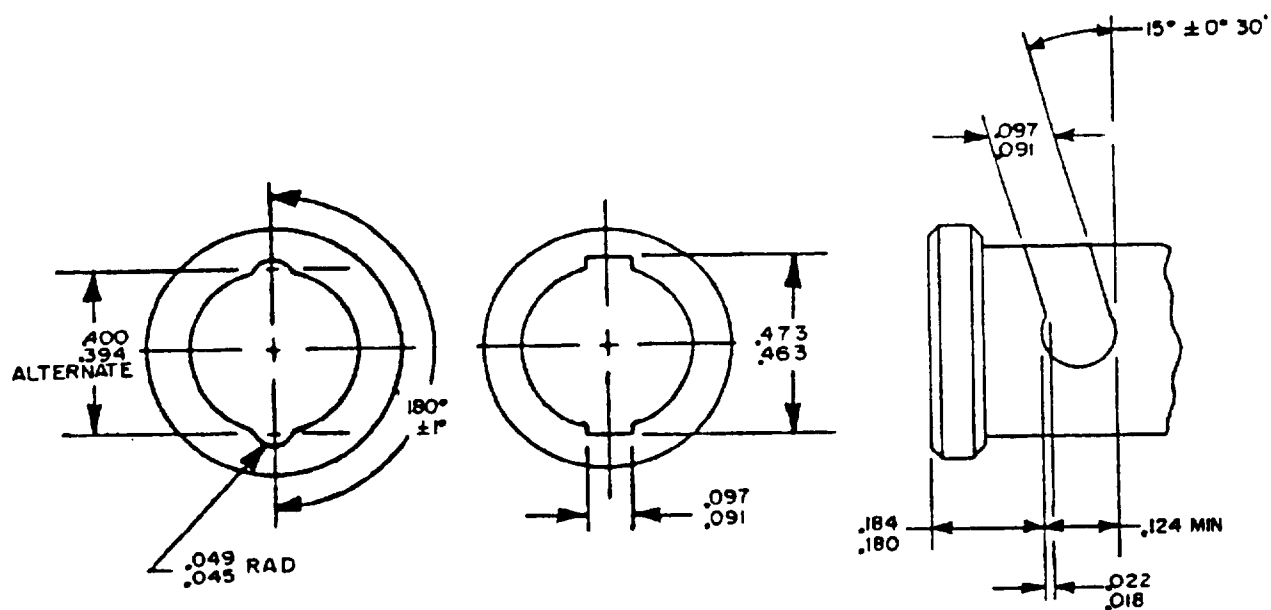

Inches	mm	Inches	mm
.018	0.46	.180	4.57
.022	0.56	.184	4.67
.045	1.14	.394	10.01
.049	1.24	.400	10.16
.091	2.31	.463	11.76
.097	2.46	.473	12.01
.124	3.15		

FIGURE 102-2. Interface, series TWBNC, coupling nut.



MIL-STD-348A

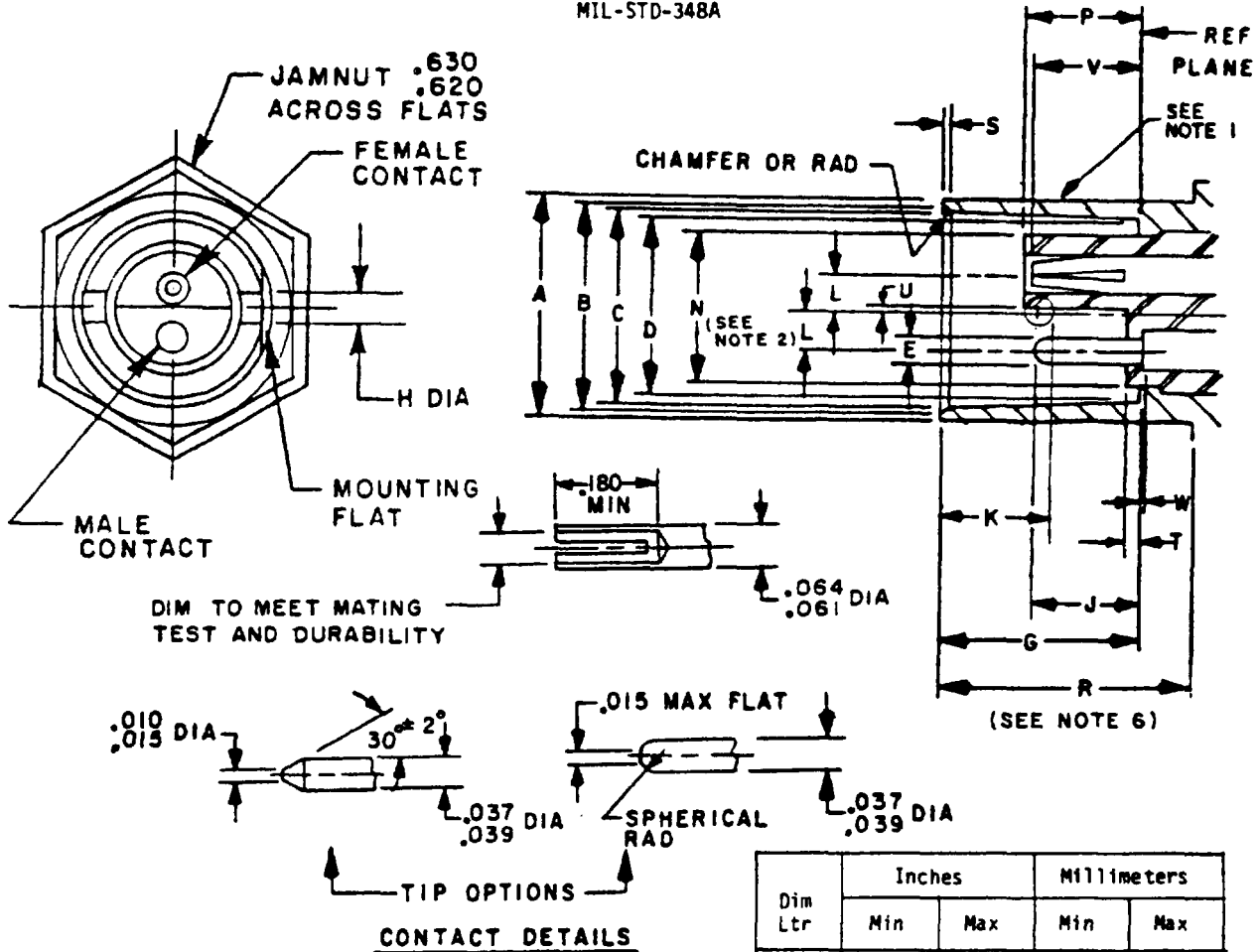

Inches	mm
.005	0.13
.010	0.25
.015	0.38
.037	0.94
.039	0.99
.061	1.55
.064	1.63
.100	2.54
.180	4.57
.620	15.75
.630	16.00

Dim Ltr	Inches		Millimeters	
	Min	Max	Min	Max
A	.378	.381	9.60	9.68
B	.345	.356	8.76	9.04
C	.327	.336	8.31	8.53
D	.319	.321	8.10	8.15
E	.037	.039	0.94	0.99
F	.432	.436	10.97	10.07
G	.329	.333	8.36	8.46
H	.075	.081	1.90	2.06
J	.171	.200	4.34	5.08
K	.204	.208	5.18	7.11
L	.062	.064	1.57	1.63
N	-	.262	-	6.65
P	.188	.206	4.78	5.23
R	.415	-	10.54	-
S	.015	.030	0.38	0.76
T	0	.028	0.0	0.71
U	.001	.004	0.03	0.10
V	.170	.200	4.32	5.08
W	0	.040	0.0	1.02

- NOTES:
1. Concave depression .100 x .005 deep between studs permitted.
  2. N dimension applies to portion of dielectric protruding beyond reference plane.
  3. Bayonet studs and plane of contacts shall be within  $\pm 3^\circ$  of orientation shown.
  4. Contacts, insulator and mounting flat shall be oriented within  $\pm 3^\circ$  of orientation shown.
  5. This interface shall meet the gauge requirements as specified in MIL-C-3655/16.
  6. Clearance for mating connector coupling nut.

FIGURE 102-3. Interface, series TWBNC, without coupling nut.

MIL-STD-348A

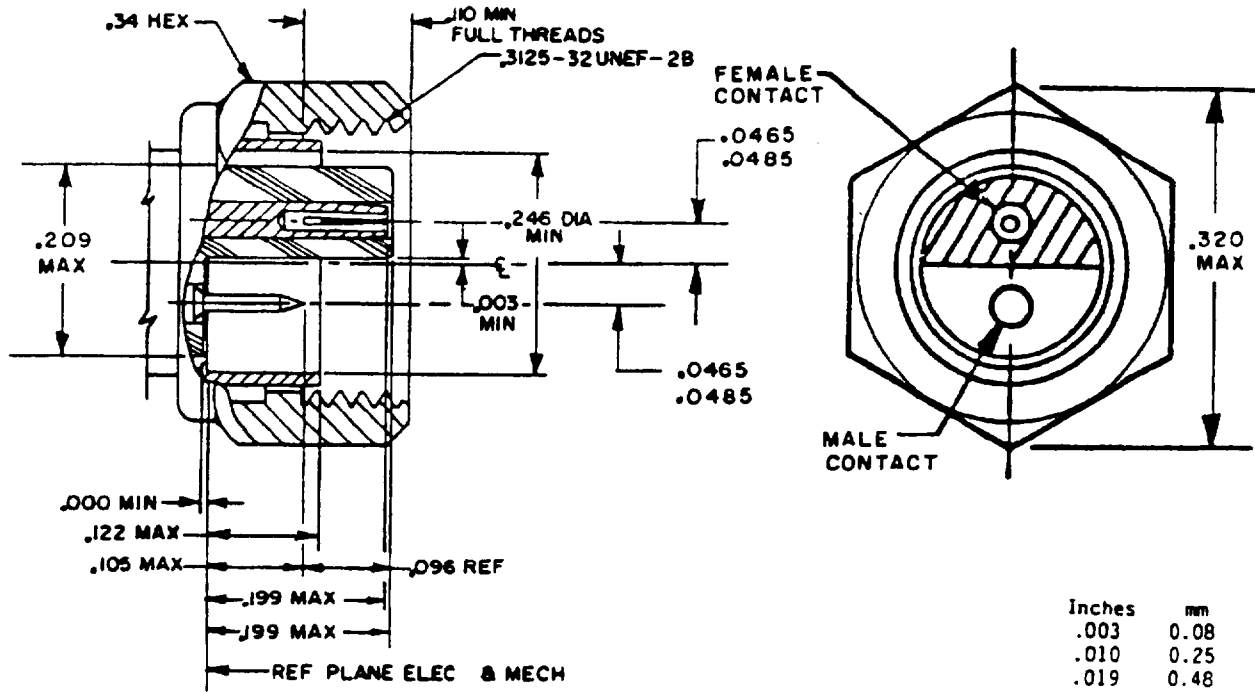

Inches	mm
.003	0.08
.010	0.25
.019	0.48
.021	0.53
.0465	1.180
.0485	1.230
.096	2.43
.105	2.67
.110	2.79
.122	3.00
.199	5.05
.209	5.31
.246	6.25
.3125	7.94
.320	8.13
.340	8.63

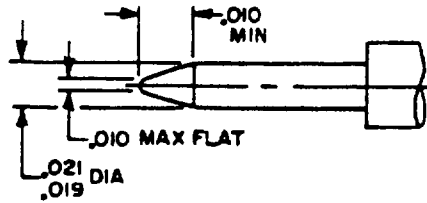
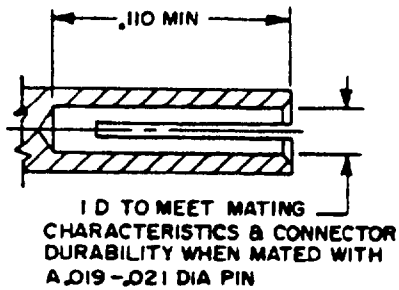

NOTES:

1. This interface shall meet the gauge requirements as specified in MIL-C-3655/18.
2. Thread gauge must go .234 (5.94 mm) minimum from reference plane.

FIGURE 103-1. Interface, series TWSMC, with coupling nut.

MIL-STD-348A

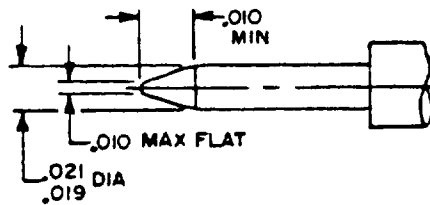
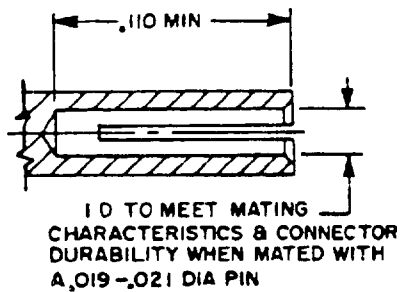
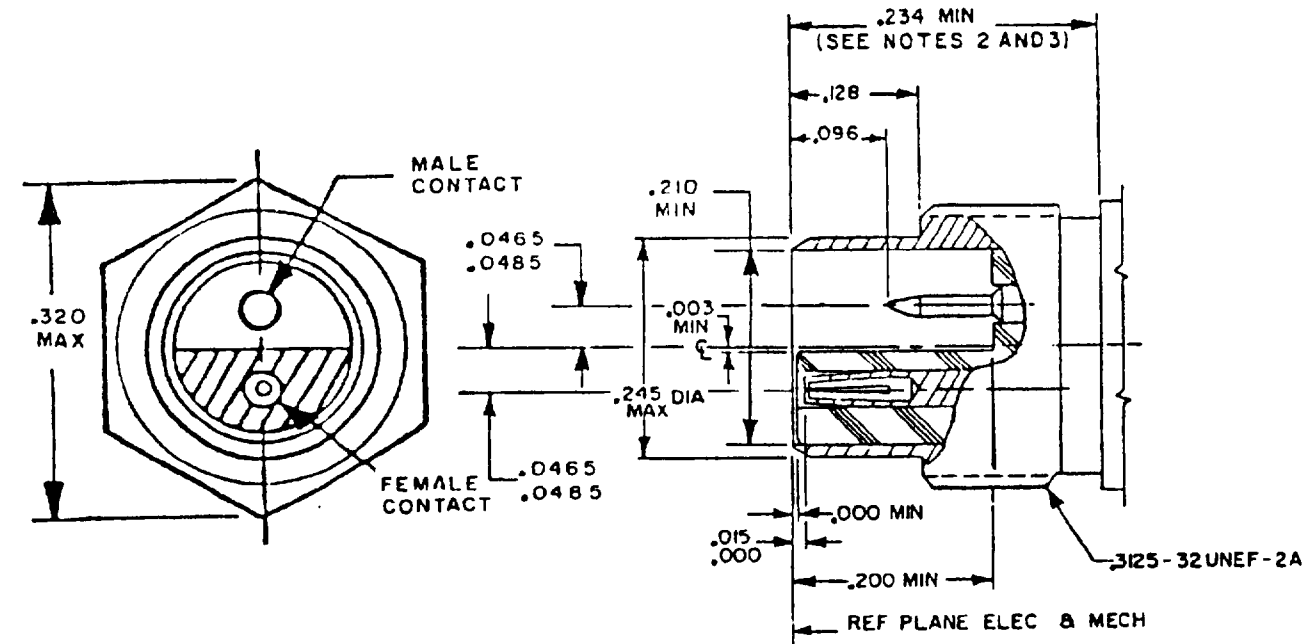

Inches	mm
.003	0.08
.010	0.25
.015	0.38
.019	0.48
.021	0.53
.0465	1.18
.0485	1.23
.096	2.44
.110	2.79
.128	3.25
.200	5.08
.210	5.33
.234	5.94
.245	6.22
.3125	7.94
.320	8.13

## NOTES:

1. This interface shall meet mating requirements as specified in MIL-C-3655/19.
2. Thread gauge must go .234 (5.94 mm) minimum from reference plane.
3. Clearance for mating connector coupling nut.

FIGURE 103-2. Interface, series TWSMC, without coupling nut.

## MIL-STD-348A

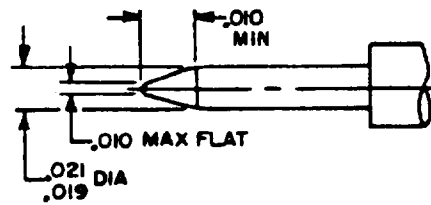
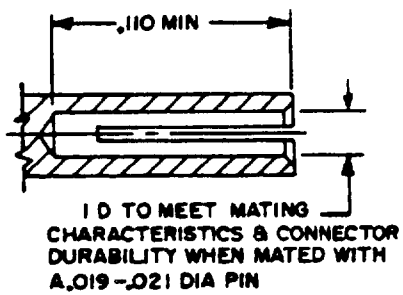
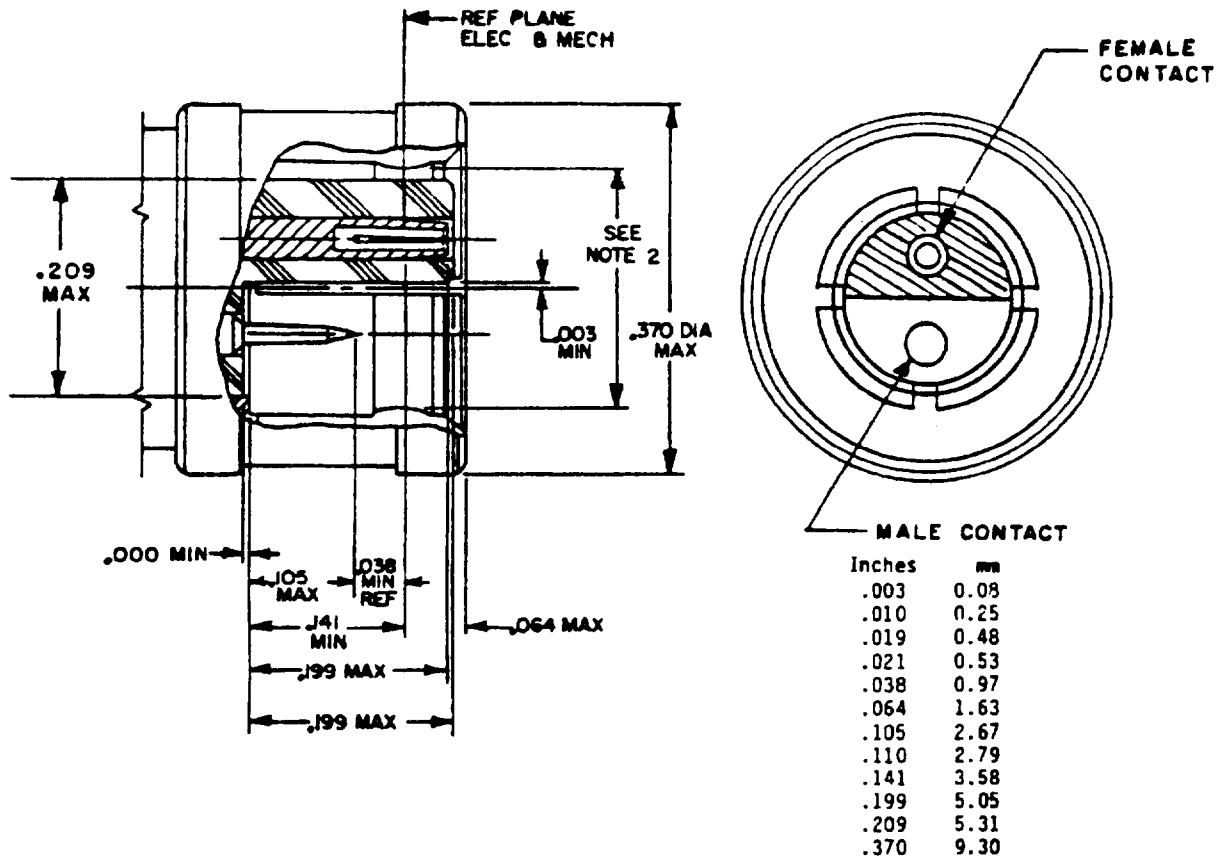

## NOTES:

1. This interface shall meet the gauge requirements as specified in MIL-C-3655/20.
2. This interface shall meet the force to engage/disengage as specified in MIL-C-39012/20.

FIGURE 104-1. Interface, series TWS<sup>MC</sup>, with coupling mechanism.

MIL-STD-348A

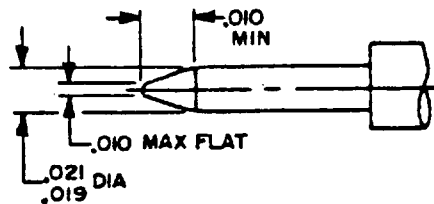
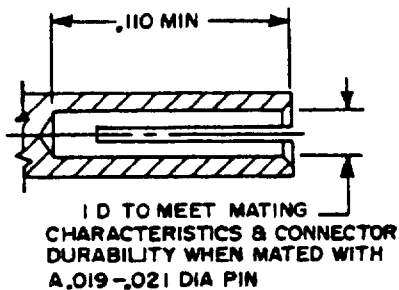
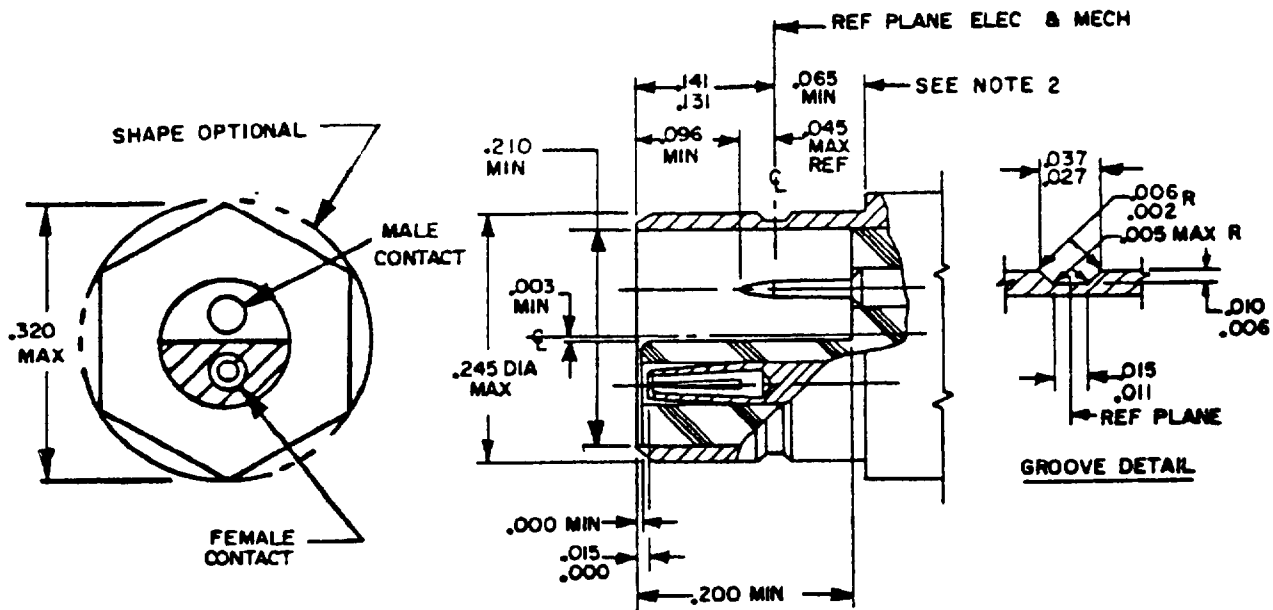

Inches	mm	Inches	mm
.002	0.05	.037	0.94
.003	0.08	.045	1.14
.005	0.13	.065	1.65
.006	0.15	.110	2.79
.010	0.25	.131	3.33
.011	0.28	.141	3.58
.015	0.38	.200	5.08
.019	0.48	.210	5.33
.021	0.53	.245	6.22
.027	0.69	.320	8.13

NOTES:

1. This interface shall meet the mating requirements as specified in MIL-C-3655/21.
2. Clearance for mating connector coupling nut.

FIGURE 104-2. Interface, series TWSMB, without coupling mechanism.

**MIL-STD-348A**

**SECTION 200**

**Interface Dimensions for MIL-C-49142**

**Section 201                      Series TRB**

**Section 202                      Series TRT**

MIL-STD-348A

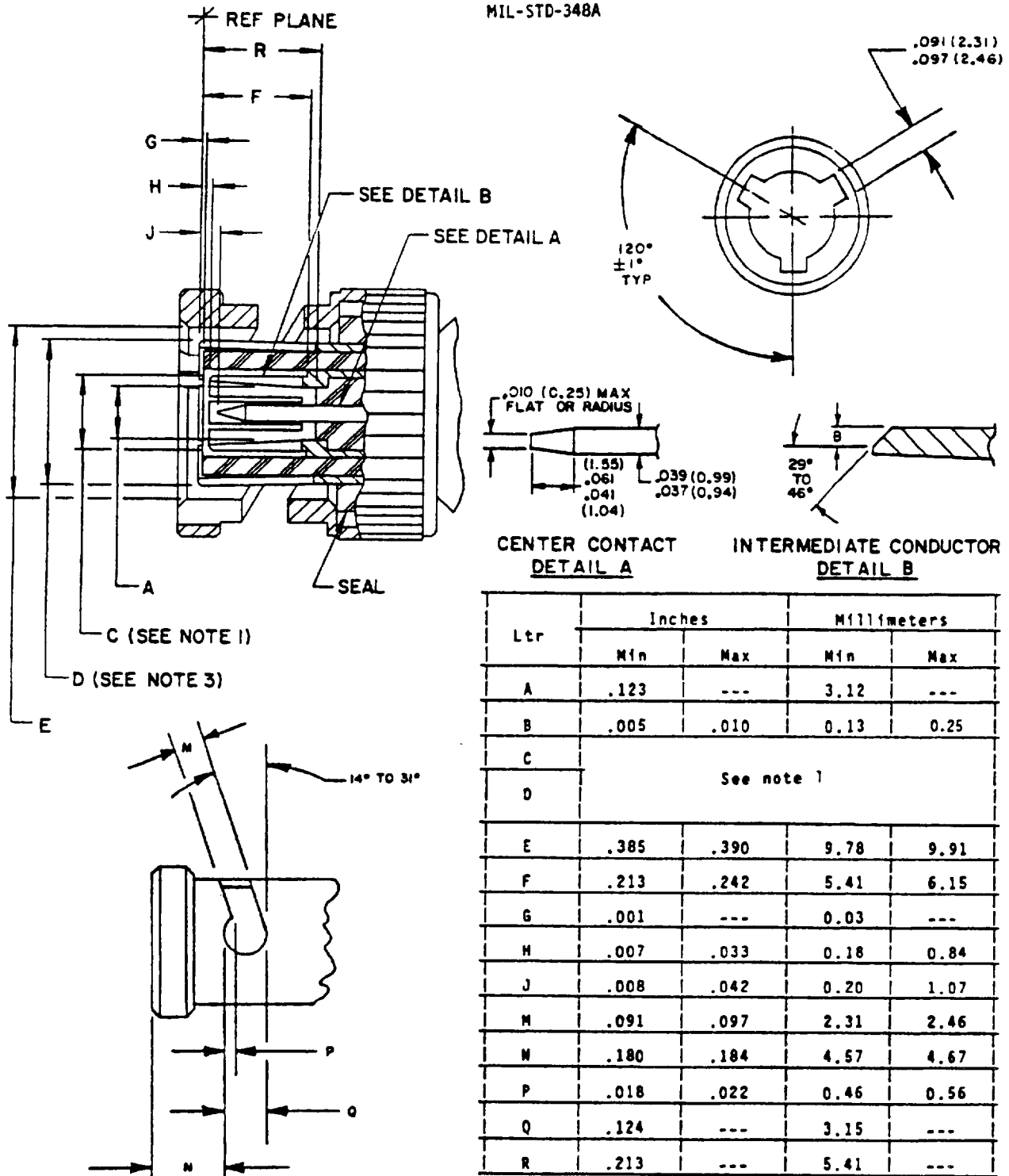

NOTES:

1. Flared to meet mating characteristic test.
2. Metric equivalents are in parentheses or tabulated.
3. This interface shall meet the gauge requirements of MIL-C-49142.

FIGURE 201-1. Interface, series, TRB, pin contact.

MIL-STD-348A

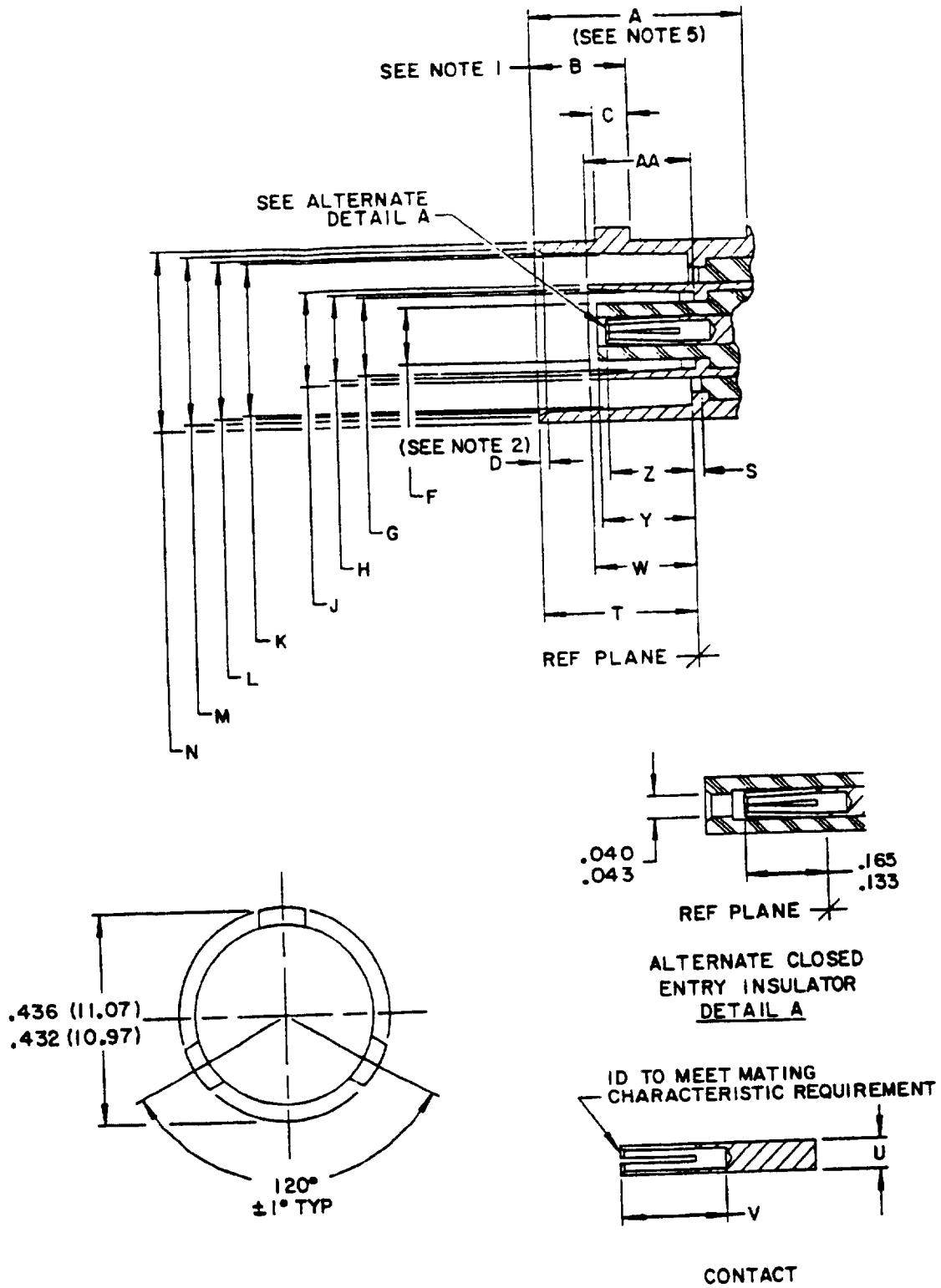

FIGURE 201-2. Interface, series TRB, socket contact.



## MIL-STD-348A

Ltr	Inches		Millimeters	
	Min	Max	Min	Max
A	.414	---	10.52	---
AA	.206	.213	5.23	5.41
B	.204	.208	5.18	5.28
C	.075	.081	1.90	2.06
D	.015	.030	0.38	0.76
F	.117	.122	2.97	3.10
G	.169	.171	4.29	4.34
H	.178	.182	4.52	4.62
J	.195	.199	4.95	5.05
K	.319	.321	8.10	8.15
L	.327	.333	8.31	8.46
M	.346	.356	8.79	9.04
N	.378	.382	9.60	9.70
S	.001	---	0.03	---
T	.327	.335	8.31	8.51
U	.062	.064	1.57	1.63
V	.213	---	5.41	---
W	.187	.213	4.75	5.41
Y	---	.213	---	5.41
Z	.165	.203	4.19	5.16

## NOTES:

1. .005 (0.13 mm) flat permissible to meet dimension B.
2. Chamfer or radius.
3. Metric equivalents are in parentheses or tabulated.
4. This interface shall meet the gauge requirements of MIL-C-49142.
5. Clearance for mating connector coupling nut.

FIGURE 201-2. Interface, series TRB, socket contact - Continued.

MIL-STD-348A

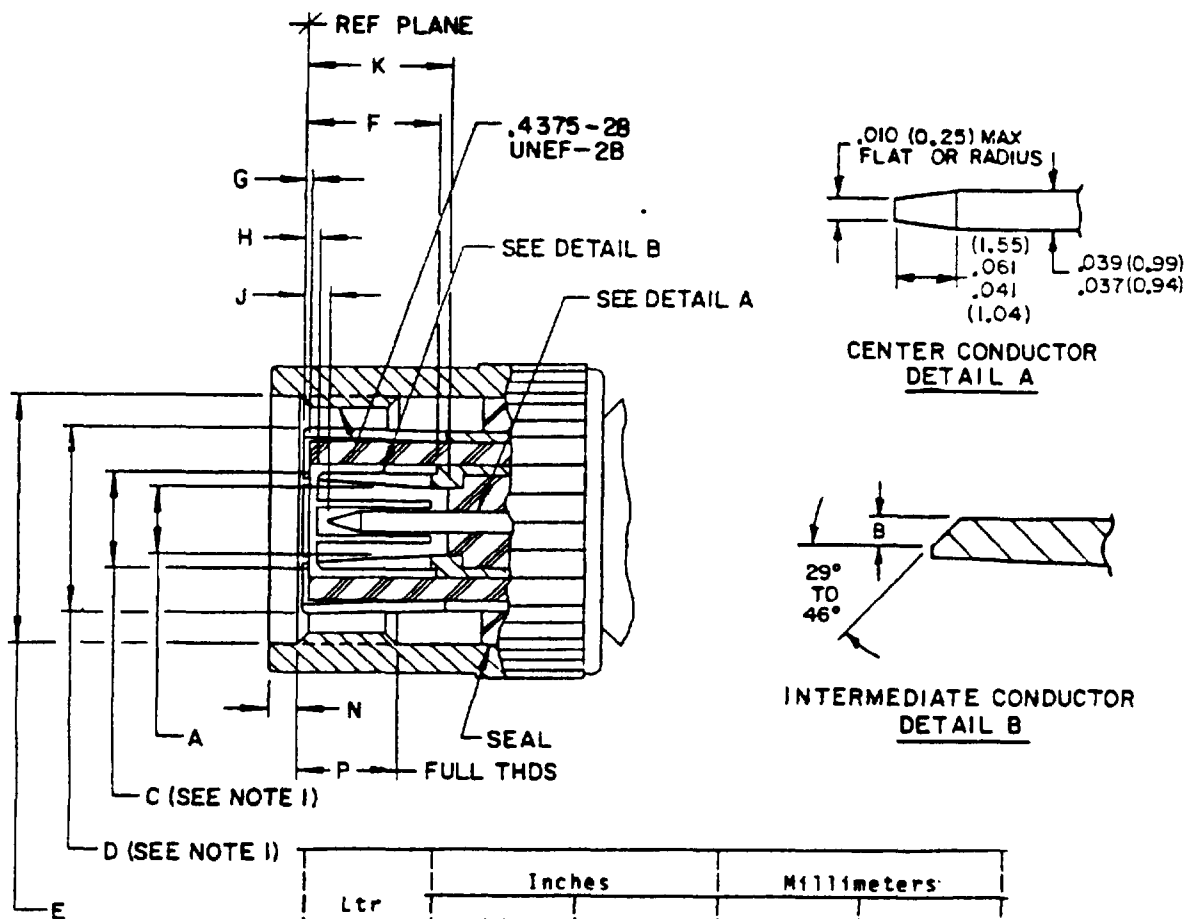

Ltr	Inches		Millimeters	
	Min	Max	Min	Max
A	.123	---	3.12	---
B	.005	.010	0.13	0.25
C	.172	.178	4.37	4.52
D	See note 1			
E	.440	---	11.18	---
F	.213	.242	5.41	6.15
G	.001	---	0.03	---
H	.007	.033	0.18	0.84
J	.008	.042	0.20	1.07
K	.213	---	5.41	---
N	.063	---	1.60	---
P	.156	---	3.96	---

NOTES:

1. Flared to meet mating characteristic test.
2. Metric equivalents are in parentheses or tabulated.
3. This interface shall meet the gauge requirements of MIL-C-49142.

FIGURE 202-1. Interface, series TRT, pin contact.

MIL-STD-348A

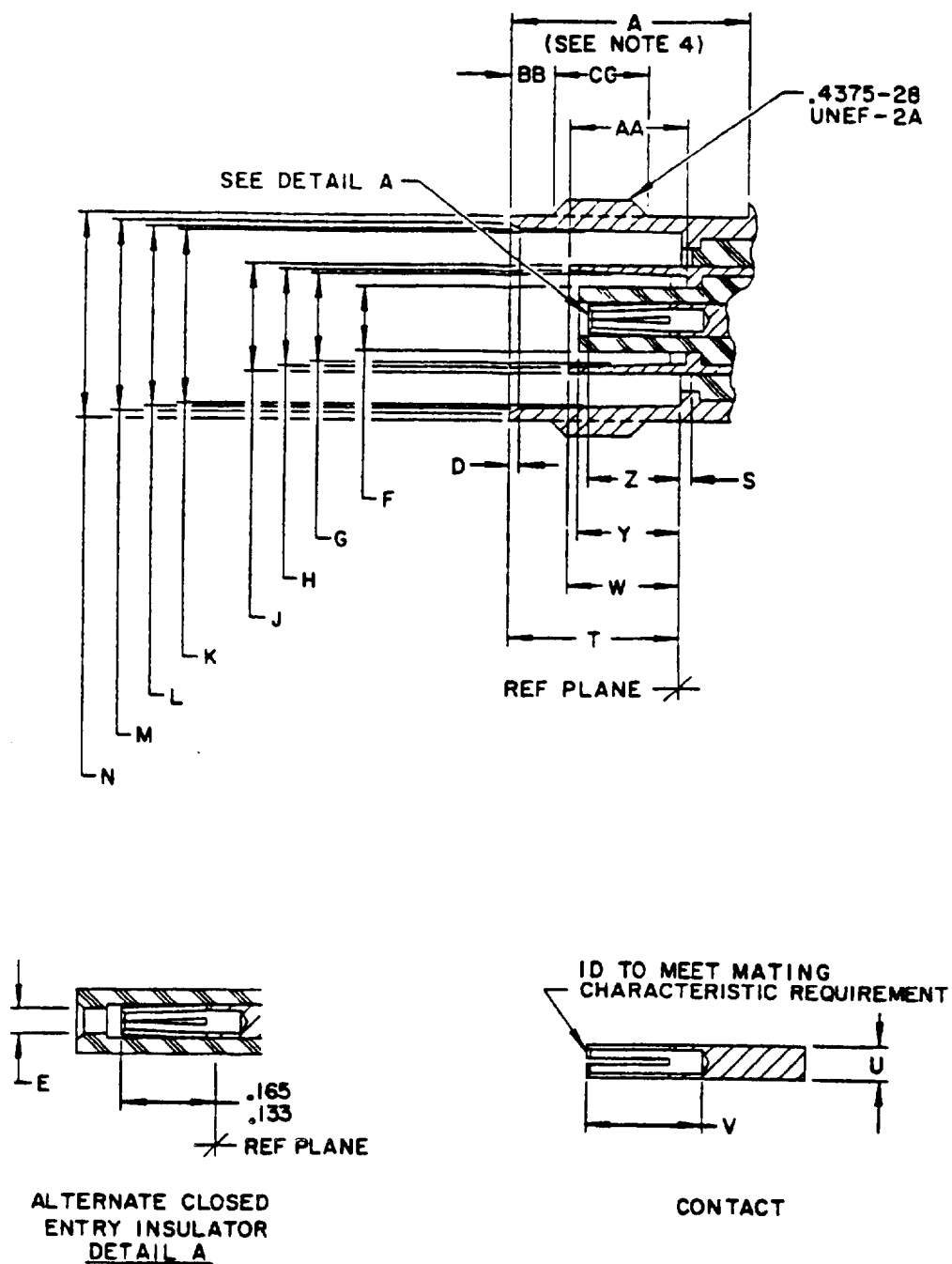

FIGURE 202-2. Interface, series TRT, socket contact.

## MIL-STD-348A

Ltr	Inches		Millimeters	
	Min	Max	Min	Max
A	.414	---	10.52	---
D	.015	.030	0.38	0.76
E	.040	.043	1.02	1.09
F	.117	.122	2.97	3.10
G	.169	.171	4.29	4.34
H	.178	.182	4.52	4.62
J	.195	.199	4.95	5.05
K	.319	.321	8.10	8.15
L	.327	.333	8.31	8.46
M	.346	.356	8.79	9.04
N	.378	.382	9.60	9.70
S	.001	---	0.03	---
T	.327	.335	8.31	8.51
U	.062	.064	1.57	1.63
V	.213	---	5.41	---
W	.187	.213	4.75	5.41
Y	---	.213	---	5.41
Z	.165	.263	4.19	5.16
AA	.201	.213	5.23	5.41
BB	.068	.088	1.73	2.24
CC	.187	---	4.75	---

## NOTES:

1. Metric equivalents are tabulated.
2. Chamfer or radius.
3. This interface shall meet the gauge requirements of MIL-C-49142.
4. Clearance for mating connector coupling nut.

FIGURE 202-2. Interface, series TRT, socket contact - Continued.

## MIL-STD-348A

## SECTION 300

Interface Dimensions for MIL-C-3643, MIL-C-3650, MIL-C-26637,  
MIL-C-39012, MIL-A-55339, and MIL-C-83517

Section 301	Series BNC
Section 302	Series C
Section 303	Series MHV
Section 304	Series N
Section 305	Series QL
Section 306	Series QM
Section 307	Series QNC
Section 308	Series QSC
Section 309	Series SC
Section 310	Series SMA
Section 311	Series SMB
Section 312	Series SMC
Section 313	Series TNC
Section 314	Series SHV
Section 315	Series LC
Section 316	Environment resistant
Section 317	Series HN
Section 318	Series LT
Section 319	Series SSMA

MIL-STD-348A

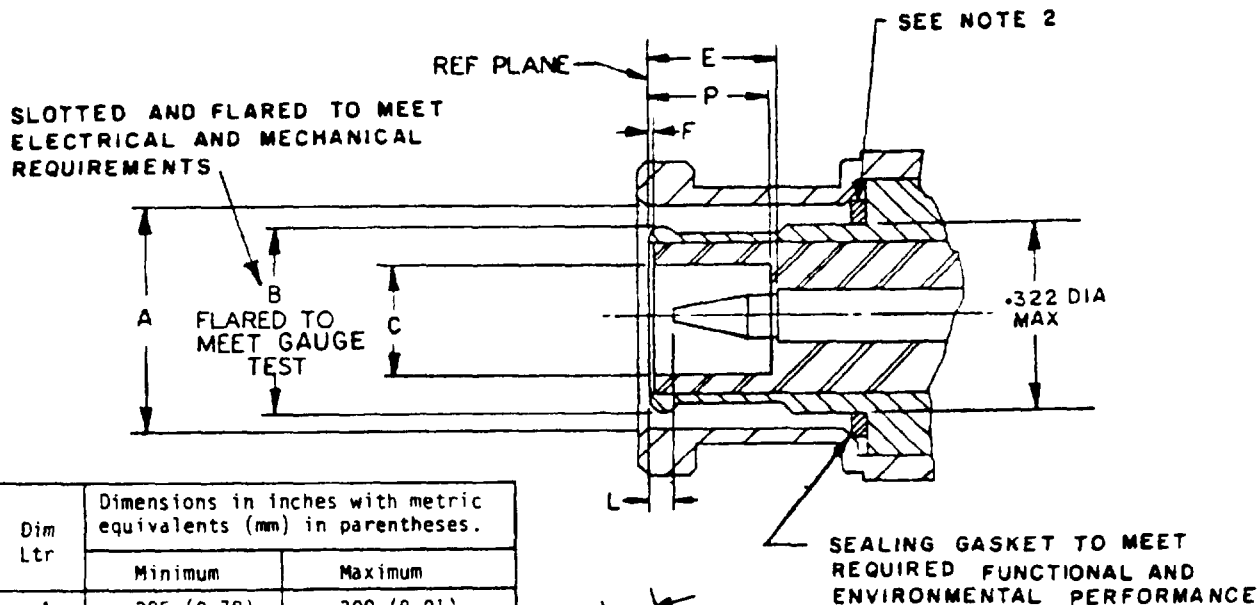

Dim Ltr	Dimensions in inches with metric equivalents (mm) in parentheses.	
	Minimum	Maximum
A	.385 (9.78)	.390 (9.91)
B	Gauge test	
C	.190 (4.83)	
D	.052 (1.32)	.054 (1.37)
E	.210 (5.33)	.230 (5.84)
F	.006 (0.15)	
G	.091 (2.31)	.097 (2.46)
H	.463 (11.76)	.473 (12.01)
H*	.394 (10.01)	.400 (10.16)
J	.124 (3.15)	
K	.091 (2.31)	.097 (2.46)
L	.003 (0.08)	
M	.018 (0.46)	.022 (0.56)
N		.025 (0.64)
P	.208 (5.28)	.228 (5.79)
Q	.078 (1.98)	
R	.081 (2.06)	.087 (2.21)
T	.045 (1.14)	.049 (1.24)
U	.180 (4.57)	.184 (4.67)

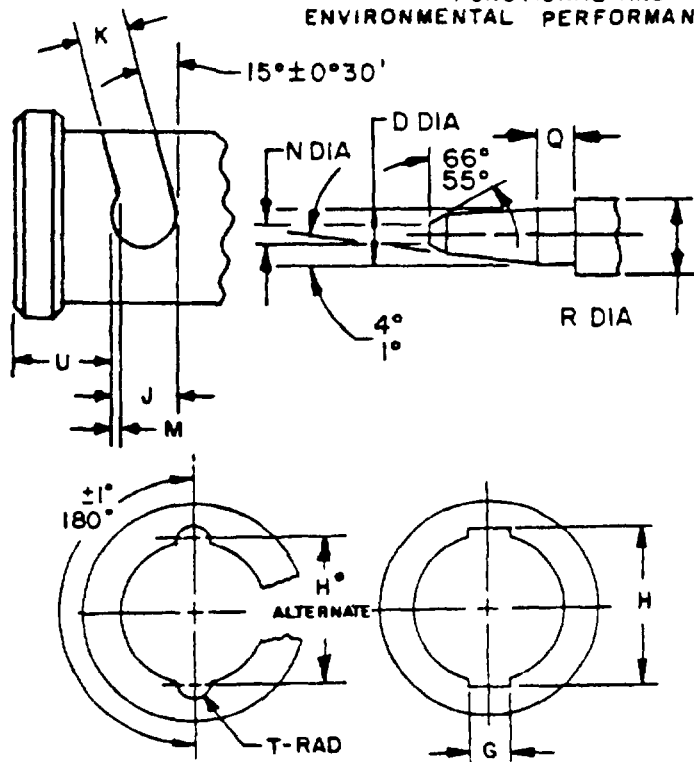

NOTES:

1. In the mated condition, the longitudinal force of the spring of the coupling mechanism shall exceed the pressure exerted by the sealing gasket by an amount necessary to insure butting of the outer contacts at the reference plane.
2. This interface shall meet the gauge requirements as specified in MIL-C-39012/16.

FIGURE 301-1. Interface, series BNC, pin contact.

MIL-STD-348A

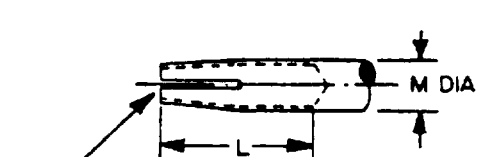
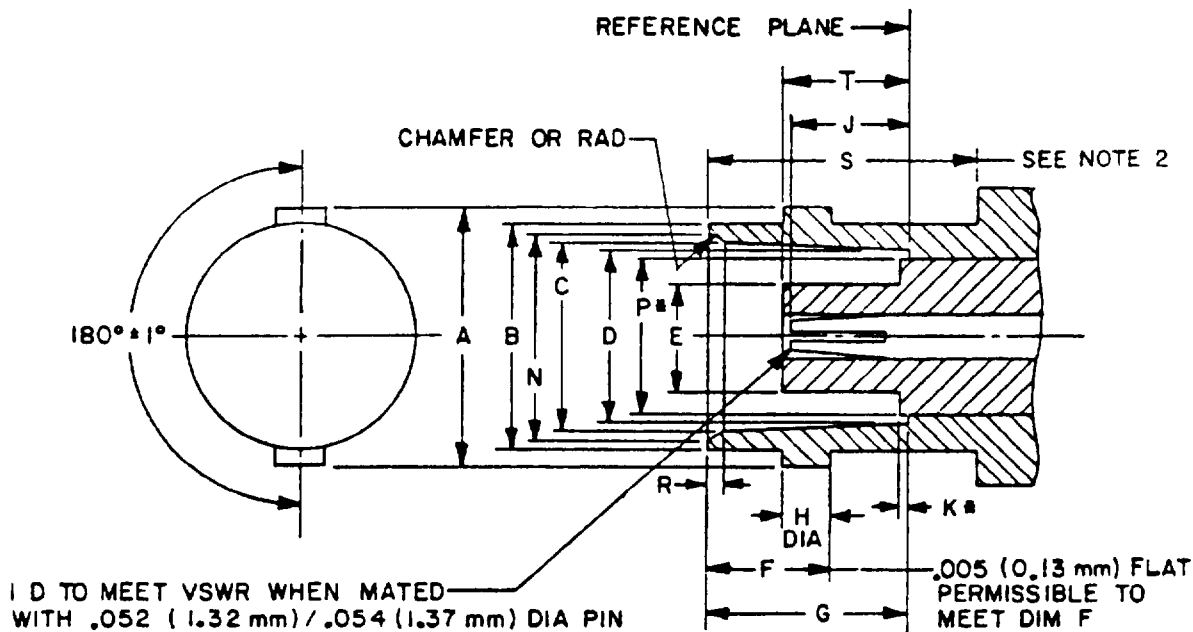

Dim Ltr	Dimensions in inches with metric equivalents (mm) in parentheses	
	Minimum	Maximum
A	.432 (10.97)	.436 (11.07)
B	.378 (9.60)	.382 (9.70)
C	.327 (8.31)	.333 (8.46)
D	.319 (8.10)	.321 (8.15)
E		.186 (4.72)
F	.204 (5.18)	.208 (5.28)
G	.327 (8.31)	.335 (8.51)
H	.075 (1.91)	.081 (2.06)
J	.186 (4.72)	.206 (5.23)
* K		.006 (0.15)
L	.195 (4.95)	
M	.081 (2.06)	.087 (2.21)
N	.346 (8.79)	.356 (9.04)
P		.256 (6.50)
R	.015 (0.38)	.030 (0.76)
S	.414 (10.52)	
T	.188 (4.78)	.208 (5.28)

\*P dimension applies to that portion (if applicable) of dielectric which extends beyond reference plane by dimension K\*.

## NOTES:

1. This interface shall meet the gauge requirements as specified in MIL-C-39012/17.
2. Clearance for mating connector coupling nut.

FIGURE 301-2. Interface, series BNC, socket contact.

MIL-STD-348A

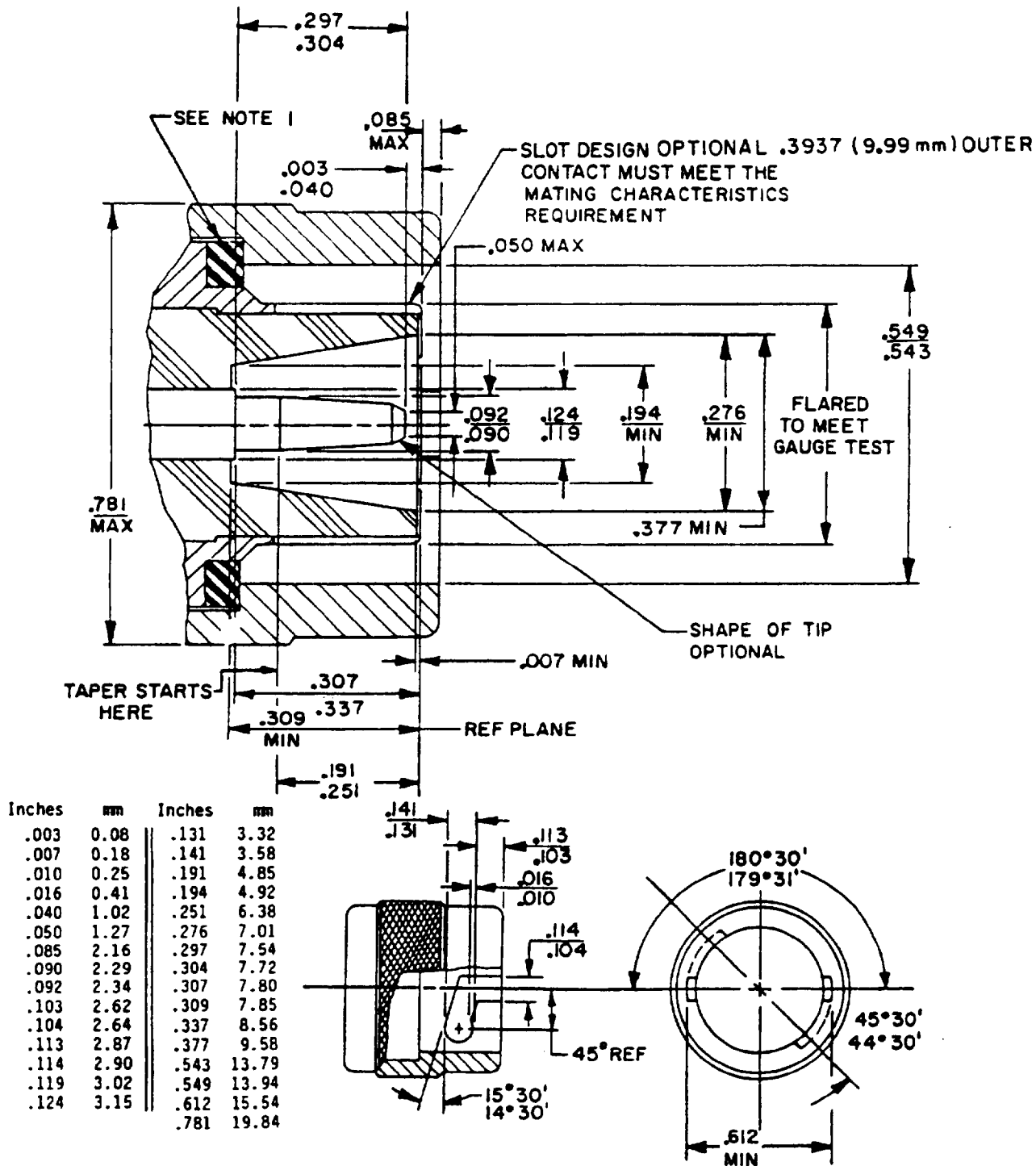

NOTES:

1. In the mated condition, the longitudinal force of the spring of the coupling mechanism shall exceed the pressure exerted by the sealing gasket by an amount necessary to insure butting of the outer contacts at the reference plane.
2. This interface shall meet the gauge requirements as specified in MIL-C-39012/6.
3. The I.D. of outer contact when inserted into a .411 (10.44 mm) maximum ring gauge shall be .377 (9.58 mm) minimum.

FIGURE 302-1. Interface, series C, pin contact.



302.2

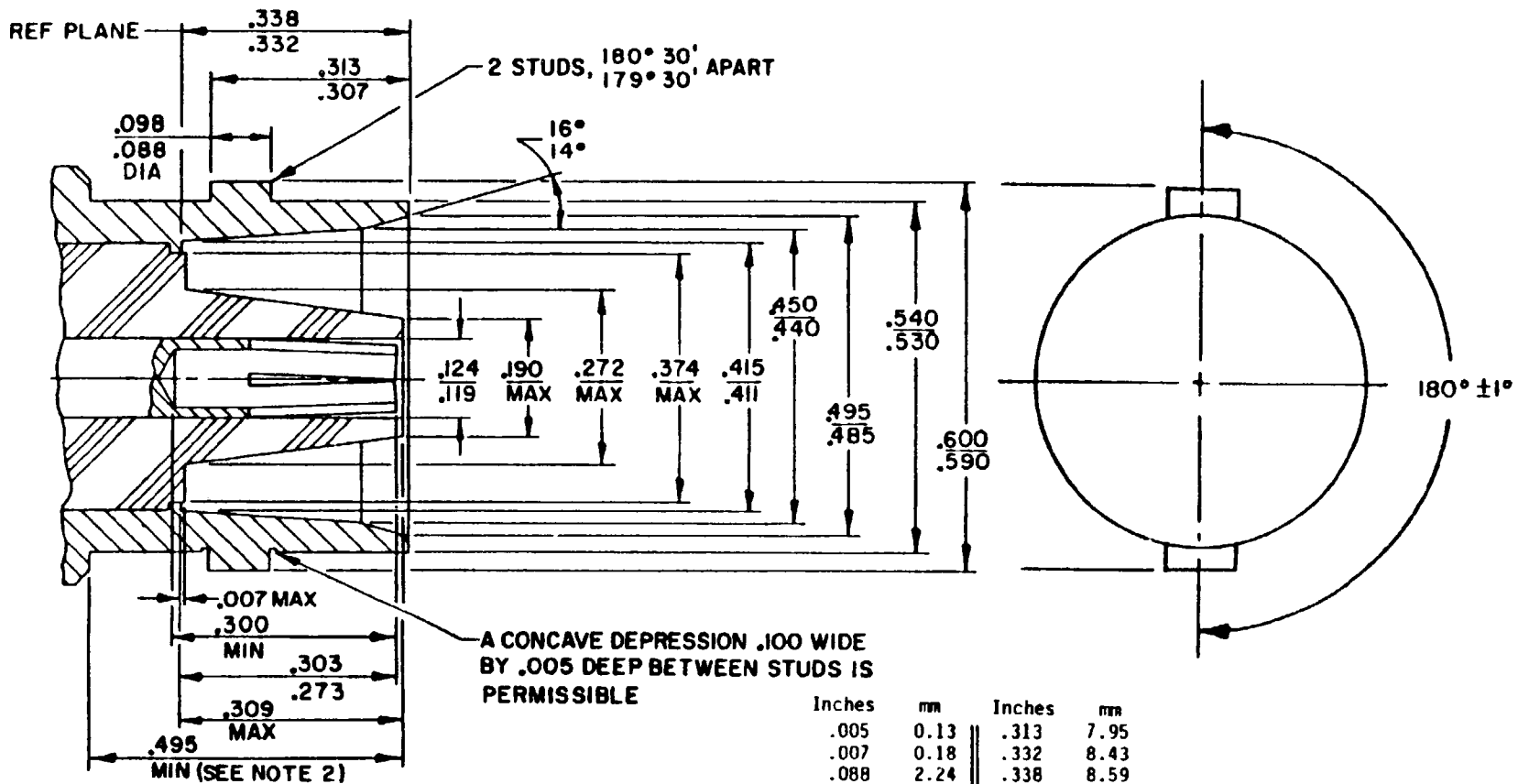

MIL-STD-348A

NOTES:

1. This interface shall meet the gauge requirements as specified in MIL-C-39012/7.
2. Clearance for mating connector coupling nut.

FIGURE 302-2. Interface, series C, socket contact.

MIL-STD-348A

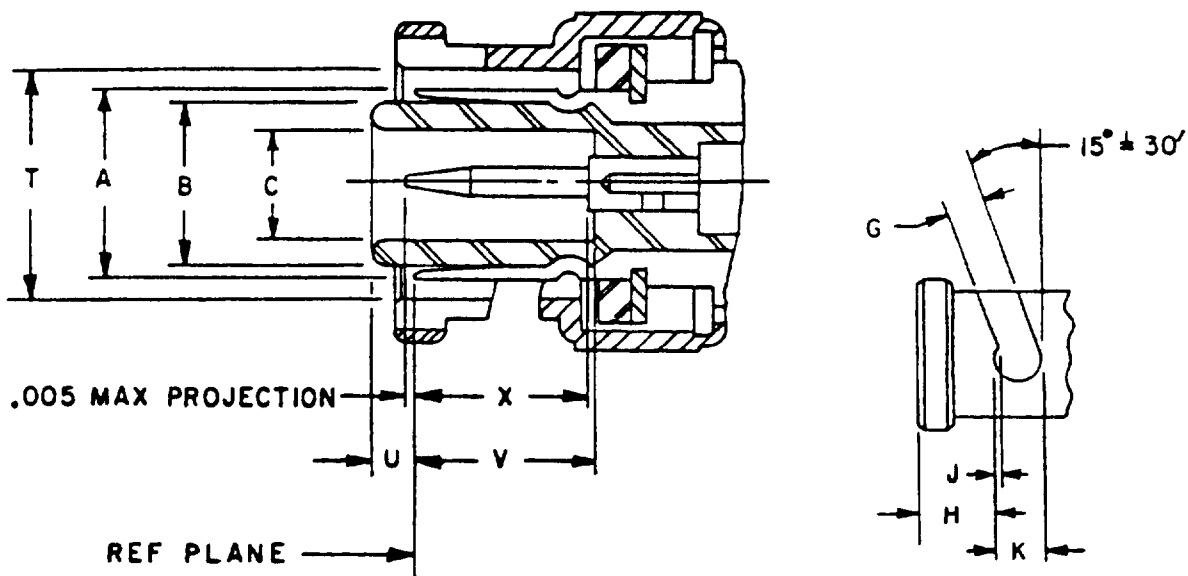

Dfm Ltr	Dimensions in inches with metric equivalents (mm) in parentheses	
	Minimum	Maximum
A	Gauge test	
B	.278 (7.06)	.282 (7.16)
C	.190 (4.83)	.194 (4.93)
G	.091 (2.31)	.097 (2.46)
H	.180 (4.57)	.184 (4.67)
J	.018 (0.46)	.022 (0.56)
K	.124 (3.15)	
L	.463 (11.76)	.473 (12.01)
M	.394 (10.01)	.400 (10.16)
N	.091 (2.31)	.097 (2.46)
P	.089 (2.26)	.091 (2.31)
Q	.207 (5.26)	
R		.025 (0.64)
S	.052 (1.32)	.054 (1.37)
T	.385 (9.78)	.390 (9.91)
U		.086 (2.18)
V	.302 (7.67)	
X	.300 (7.62)	
Z	.045 (1.14)	.049 (1.24)

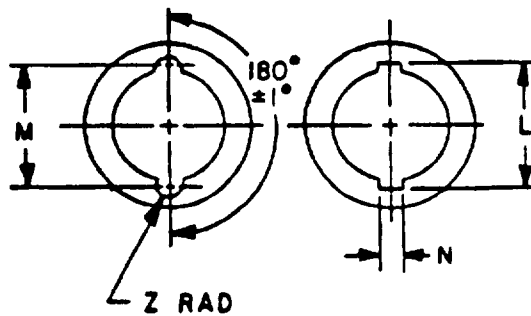
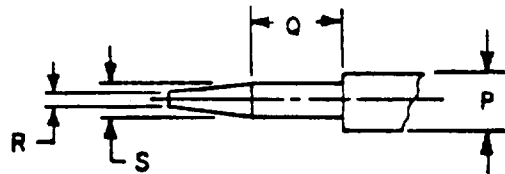

NOTE: This interface shall meet the gauge requirements as specified in MIL-C-39012/100.

FIGURE 303-1. Interface, series MHV, pin contact.

MIL-STD-348A

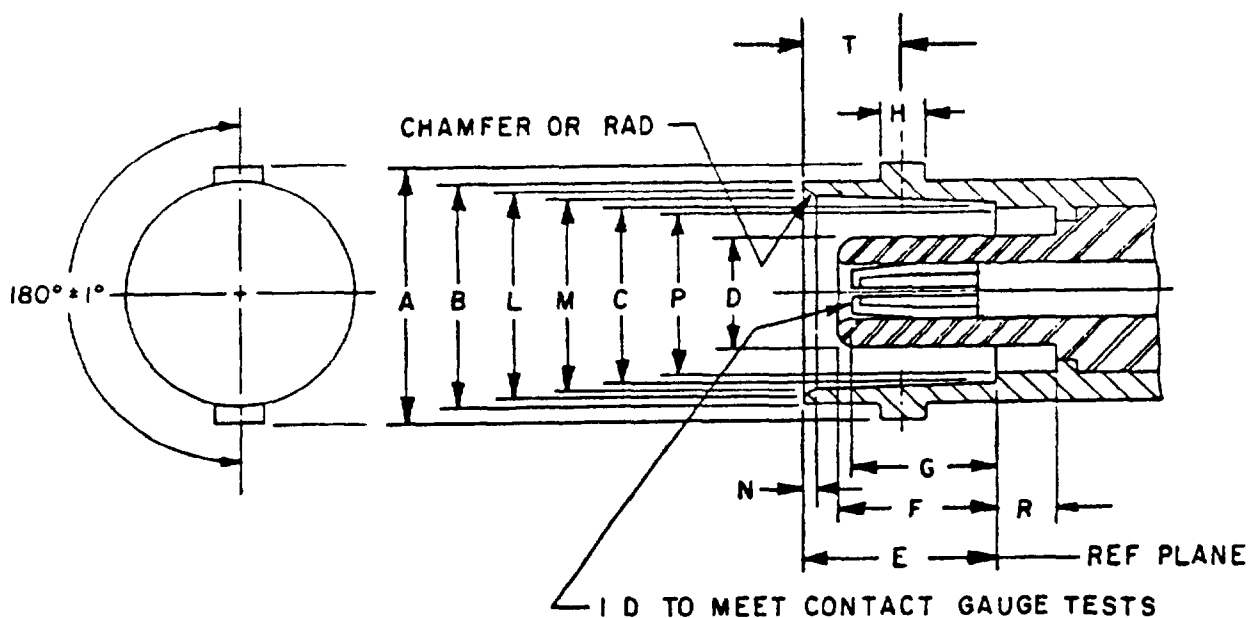

Dim Ltr	Dimensions in inches with metric equivalents (mm) in parentheses.	
	Minimum	Maximum
A	.432 (10.97)	.436 (11.07)
B	.378 (9.60)	.382 (9.70)
C	.319 (8.10)	.321 (8.15)
D		.186 (4.72)
E	.327 (8.31)	.335 (8.51)
F	.289 (7.34)	.311 (7.90)
G	.253 (6.43)	.280 (7.11)
H	.075 (1.91)	.081 (2.06)
J	.270 (6.86)	
K	.081 (2.06)	.091 (2.31)
L	.346 (8.79)	.356 (9.04)
M	.327 (8.31)	.333 (8.46)
N	.015 (0.38)	.030 (0.76)
P	.284 (7.21)	.290 (7.37)
R	.086 (2.18)	
T	.165 (4.19)	.169 (4.29)

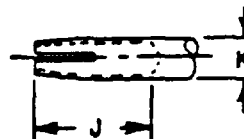

NOTE: This interface shall meet the gauge requirements as specified in MIL-C-39012/101.

FIGURE 303-2. Interface, series MHV, socket contact.

MIL-STD-348A

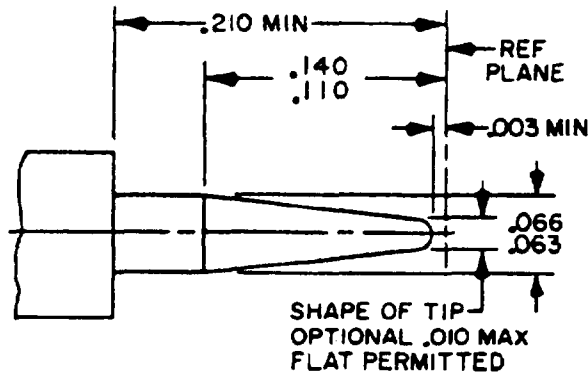
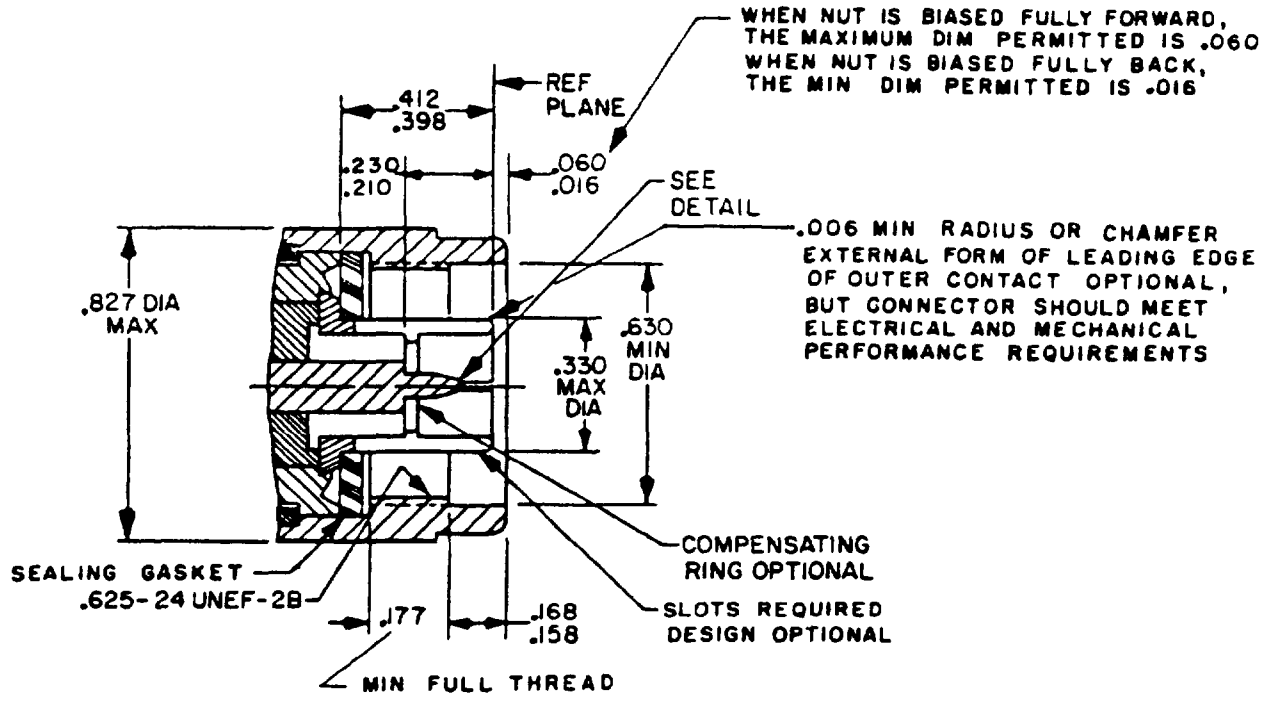

Inches	MM	Inches	MM
.003	0.08	.177	4.50
.010	0.25	.210	5.33
.016	0.41	.230	5.84
.060	1.52	.330	8.38
.063	1.60	.398	10.11
.066	1.68	.412	10.46
.110	2.79	.625	15.88
.140	3.56	.630	16.00
.158	4.01	.827	21.01
.168	4.27		

NOTE: This interface shall meet the gauge requirements as specified in MIL-C-39012/1.

FIGURE 304-1. Interface, series N, pin contact.

MIL-STD-348A

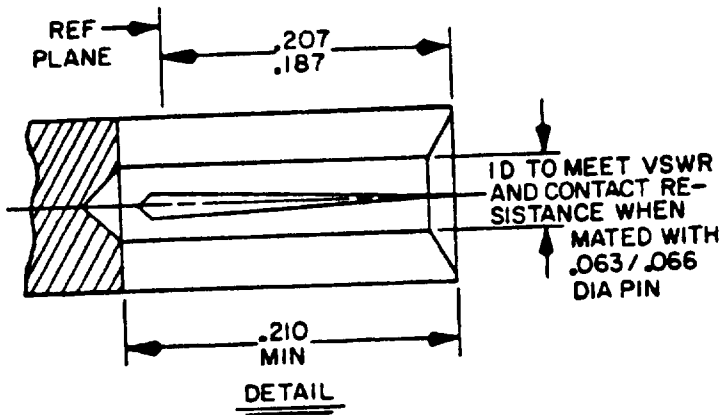
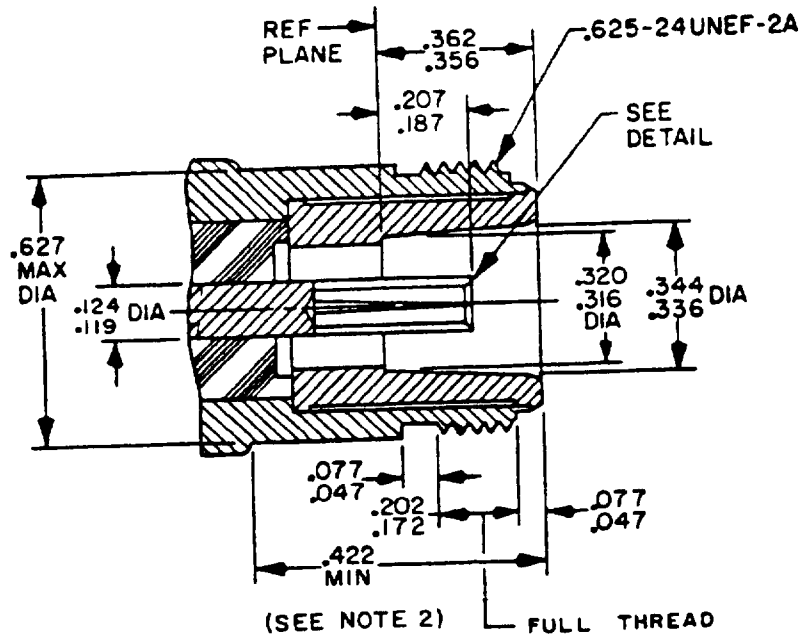

Inches	mm
.047	1.19
.063	1.60
.066	1.68
.077	1.96
.119	3.02
.124	3.15
.172	4.37
.187	4.75
.202	5.13
.207	5.26
.210	5.33
.316	8.03
.320	8.13
.336	8.53
.344	8.74
.356	9.04
.362	9.19
.422	10.72
.625	15.88
.627	15.93

NOTES:

1. This interface shall meet the gauge requirements as specified in MIL-C-39012/2.
2. Clearance for mating connector coupling nut.

FIGURE 304-2. Interface, series N, socket contact.

## MIL-STD-348A

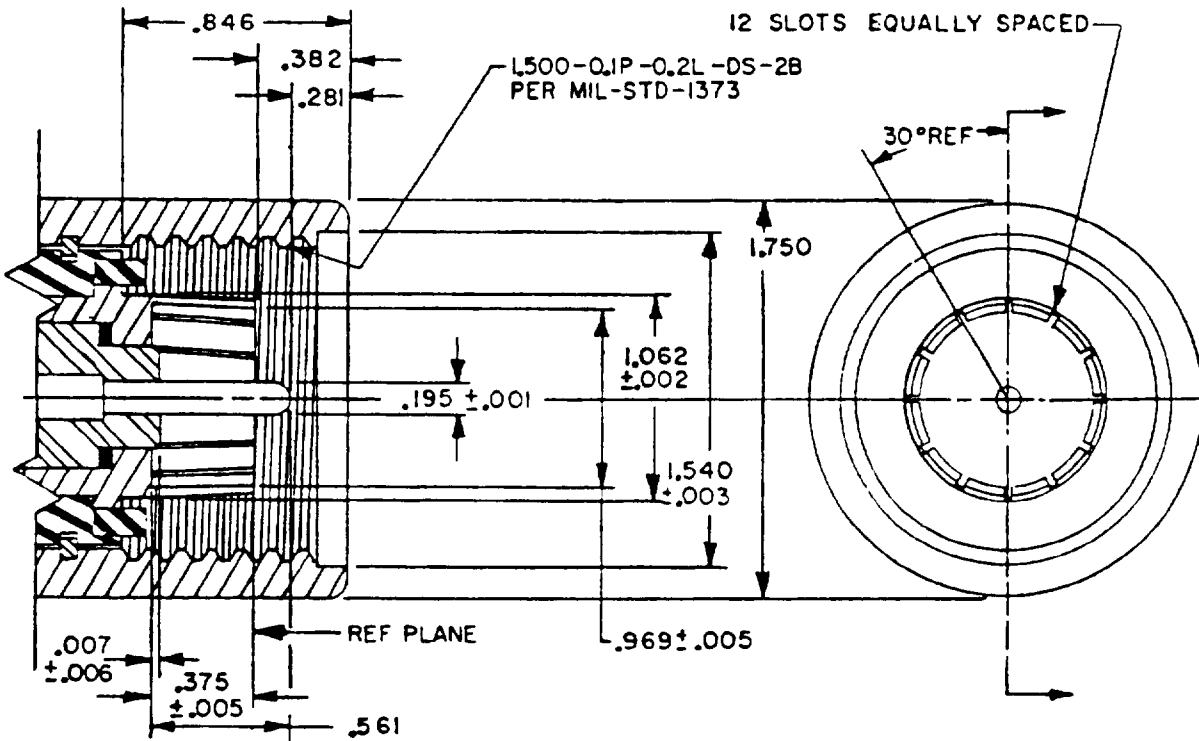

Inches	mm	Inches	mm
.001	0.03	.375	9.53
.002	0.05	.382	9.70
.003	0.08	.561	14.25
.005	0.13	.846	21.49
.006	0.15	.969	24.61
.007	0.18	1.062	27.03
.195	4.95	1.500	38.10
.281	7.14	1.540	39.12
		1.750	44.45

## NOTES:

1. This interface shall meet the gauge requirements as specified in MIL-C-39012/44.
2. Unless otherwise specified, tolerances are  $\pm .010$  (0.25 mm).

FIGURE 305-1. Interface, series QL, pin contact.

## MIL-STD-348A

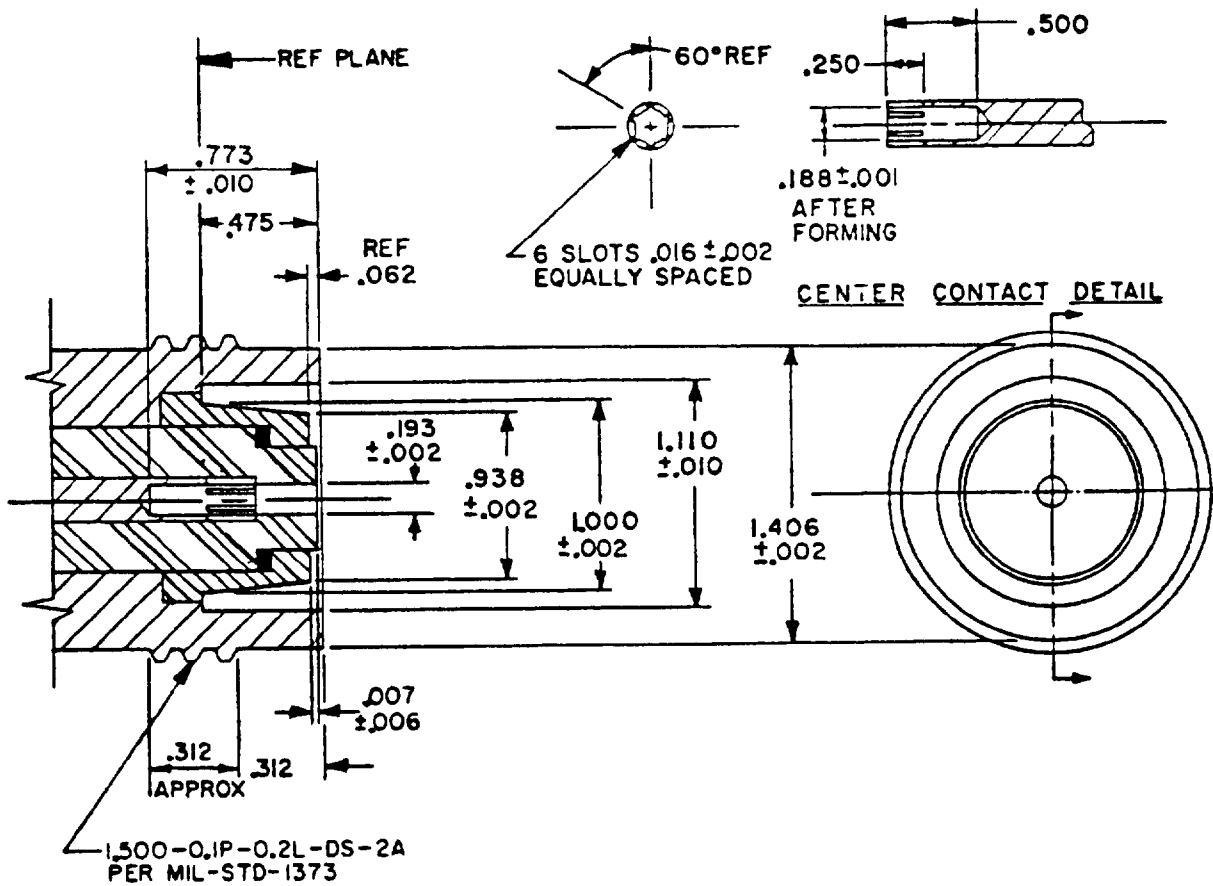

## NOTES:

1. This interface shall meet the gauge requirements as specified in MIL-C-39012/45.
2. Unless otherwise specified, tolerances are ±.010 (0.25 mm).

FIGURE 305-2. Interface, series QL, socket contact.

MIL-STD-348A

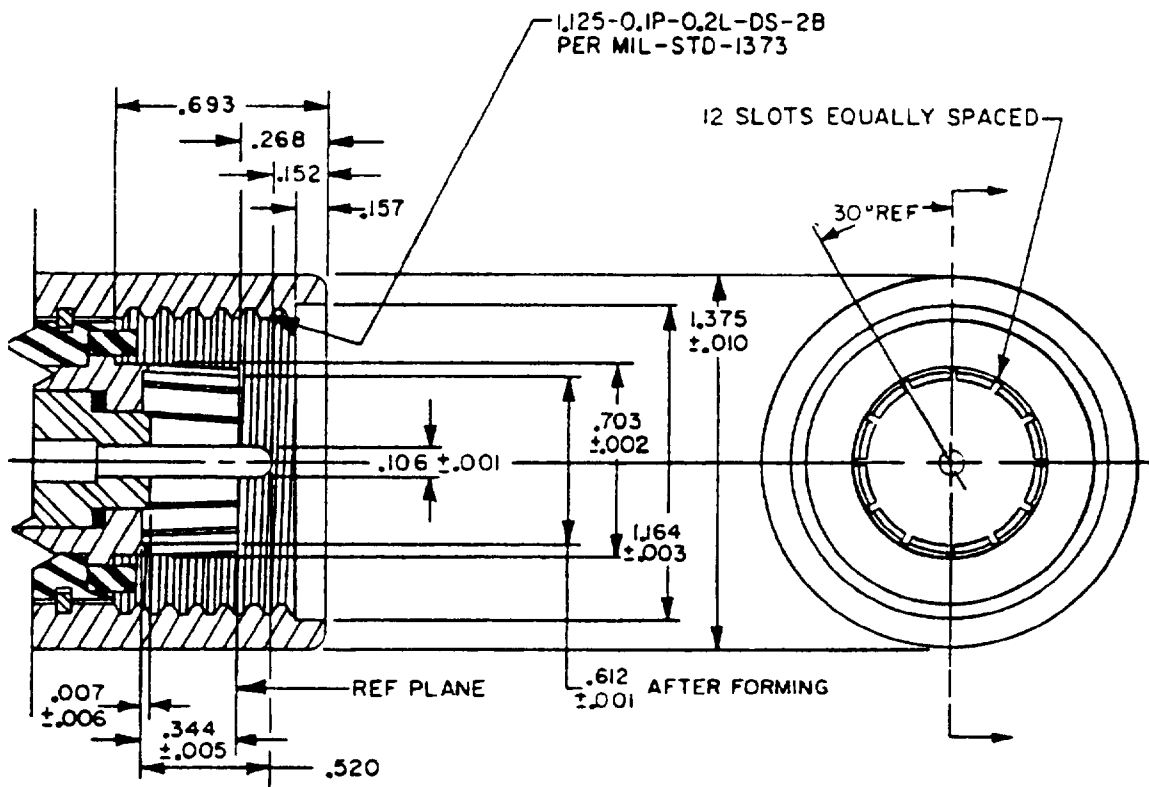

Inches	mm	Inches	mm
.001	0.03	.157	3.99
.002	0.05	.268	6.81
.003	0.08	.344	8.74
.005	0.13	.520	13.21
.006	0.15	.612	15.54
.007	0.18	.693	17.60
.010	0.25	.703	17.86
.106	2.69	1.125	28.58
.152	3.86	1.164	29.57
		1.375	34.93

NOTES:

1. This interface shall meet the gauge requirements as specified in MIL-C-39012/48.
2. Unless otherwise specified, tolerances are  $\pm .010$  (0.25 mm).

FIGURE 306-1. Interface, series OM, pin contact.



MIL-STD-348A

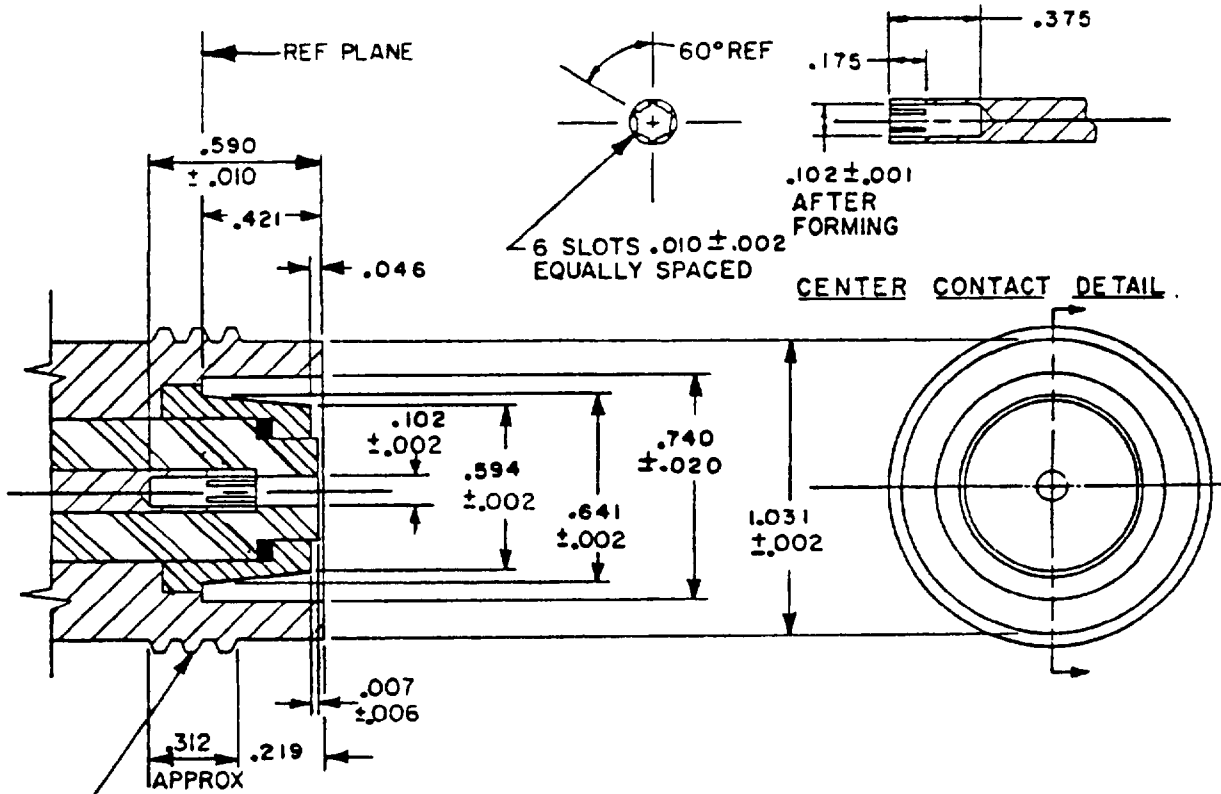

1.125 -0.1P-0.2L-DS-2A  
PER MIL-STD-1373

Inches	mm	Inches	mm
.001	0.03	.312	7.92
.002	0.05	.375	9.53
.006	0.15	.421	10.69
.007	0.18	.590	14.99
.010	0.25	.594	15.09
.020	0.51	.641	16.28
.046	1.17	.740	18.80
.102	2.59	1.031	26.19
.175	4.45	1.125	28.58
.219	5.56		

NOTES:

1. This interface shall meet the gauge requirements as specified in MIL-C-39012/49.
2. Unless otherwise specified, tolerances are  $\pm .010$  (0.25 mm).

FIGURE 306-2. Interface, series QM, socket contact.

MIL-STD-348A

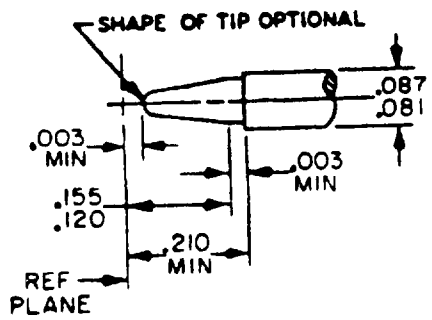
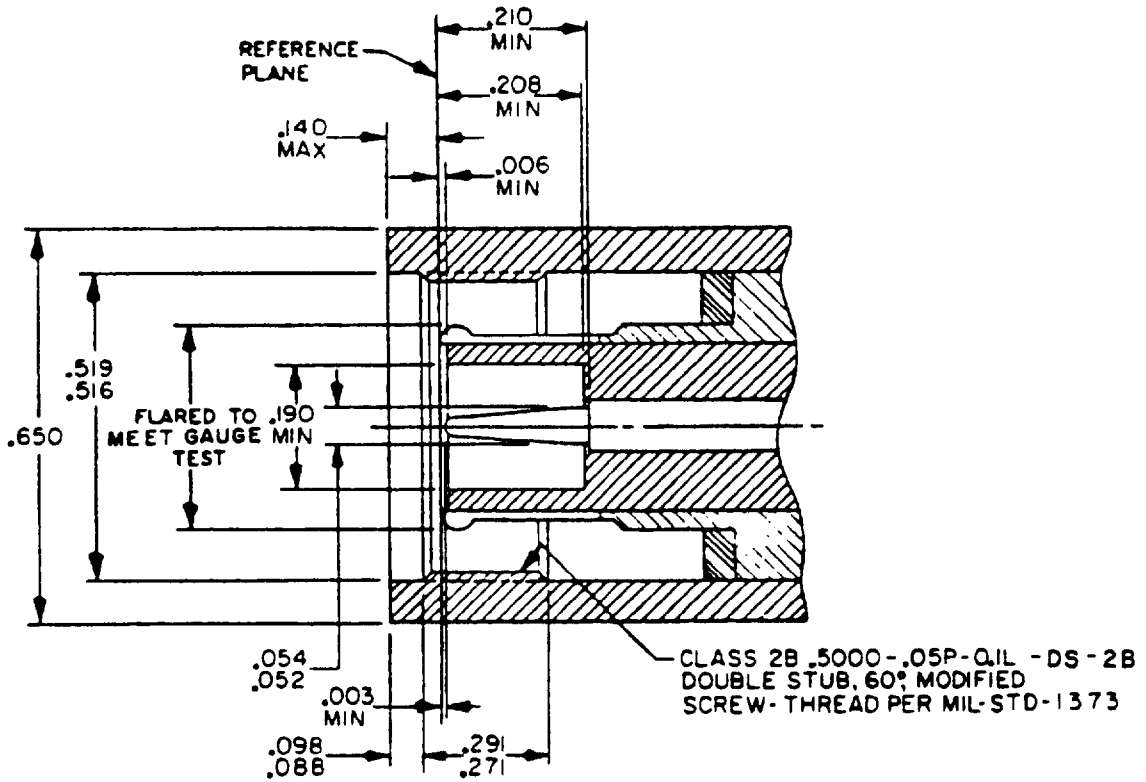

Inches	mm	Inches	mm
.003	0.08	.155	3.94
.006	0.15	.190	4.83
.052	1.32	.208	5.28
.054	1.37	.210	5.33
.081	2.06	.271	6.88
.087	2.21	.291	7.39
.088	2.24	.5000	12.70
.098	2.50	.516	13.11
.120	3.04	.519	13.18
.140	3.56	.650	16.51

NOTE: This connector shall meet the gauge requirements as specified in MIL-C-39012/65.

FIGURE 307-1. Interface, series QNC, pin contact.

MIL-STD-348A

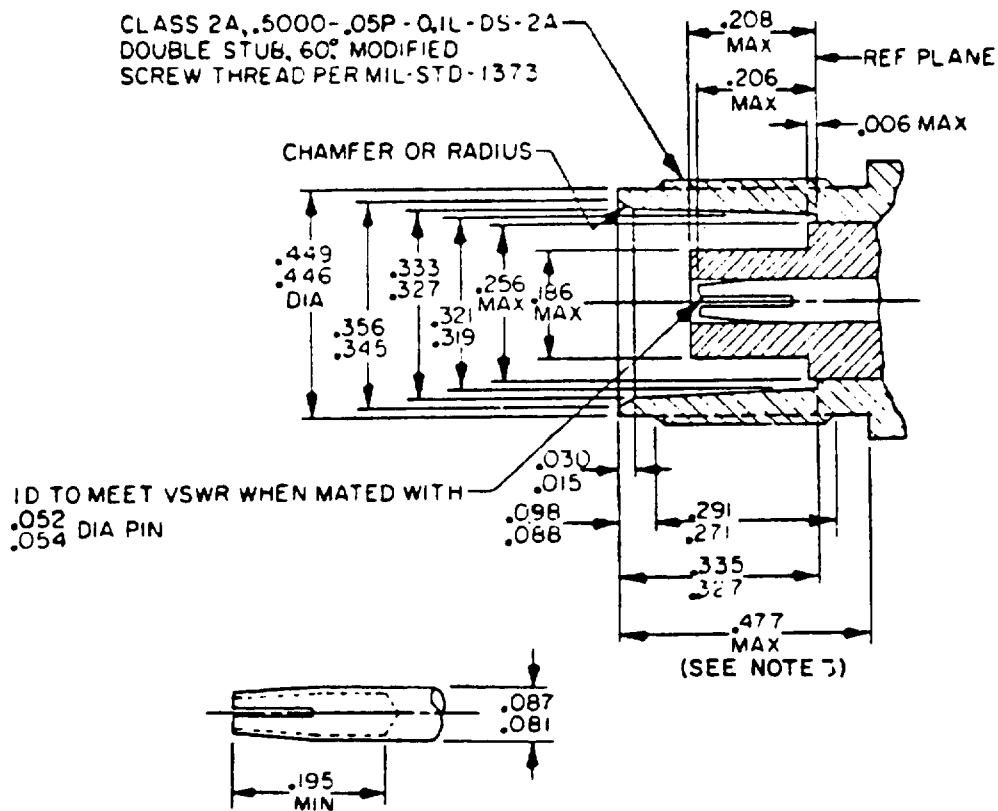

Inches	mm	Inches	mm	Inches	mm
.006	0.15	.186	4.72	.327	8.31
.015	0.38	.195	4.95	.333	8.46
.030	0.76	.206	5.23	.335	8.51
.052	1.32	.208	5.28	.345	8.76
.054	1.37	.256	6.50	.356	9.06
.081	2.06	.271	6.88	.446	11.32
.087	2.21	.291	7.39	.449	11.40
.088	2.24	.319	8.10	.477	12.12
.098	2.50	.321	8.15	.5000	12.70

## NOTES:

1. This interface shall meet the gauge requirements as specified in MIL-C-39012/89.
2. The .256 dimension applies to that portion (if applicable) of the dielectric which protrudes beyond the metal shoulder (or reference plane) by dimension .006.
3. Clearance for mating connector coupling nut.

FIGURE 307-2. Interface, series QNC, socket contact.

## MIL-STD-348A

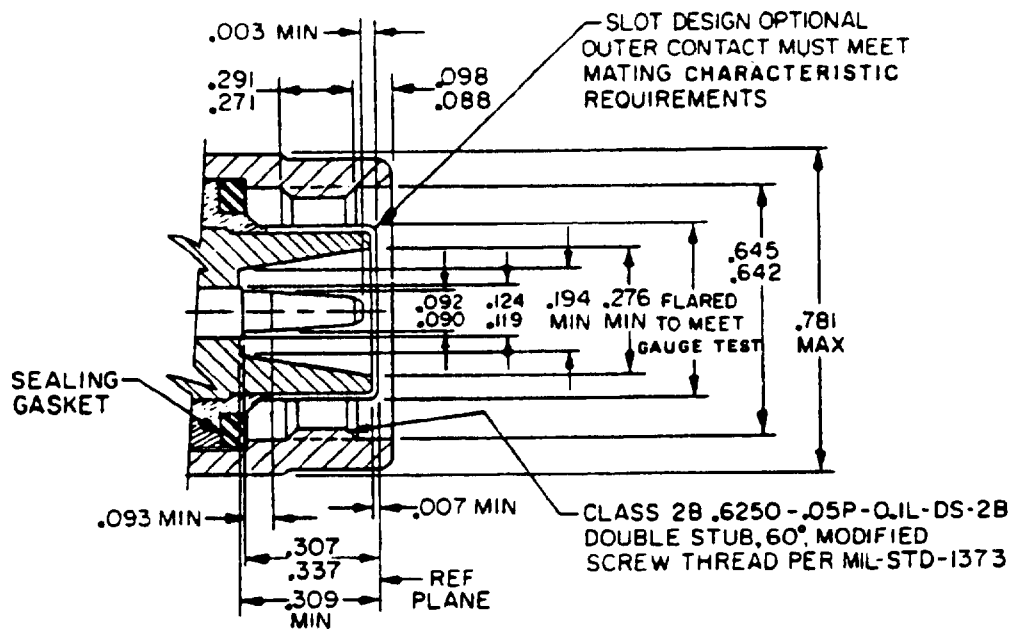

Inches	mm	Inches	mm
.003	0.08	.271	6.88
.007	0.18	.276	7.01
.088	2.24	.291	7.39
.090	2.29	.307	7.80
.092	2.34	.309	7.85
.093	2.36	.337	8.56
.098	2.50	.6250	15.88
.119	3.02	.642	16.31
.124	3.15	.645	16.38
.194	4.93	.781	19.84

NOTE: This interface shall meet the gauge requirements as specified in MIL-C-39012/84.

FIGURE 308-1. Interface, series QSC, pin contact.

MIL-STD-348A

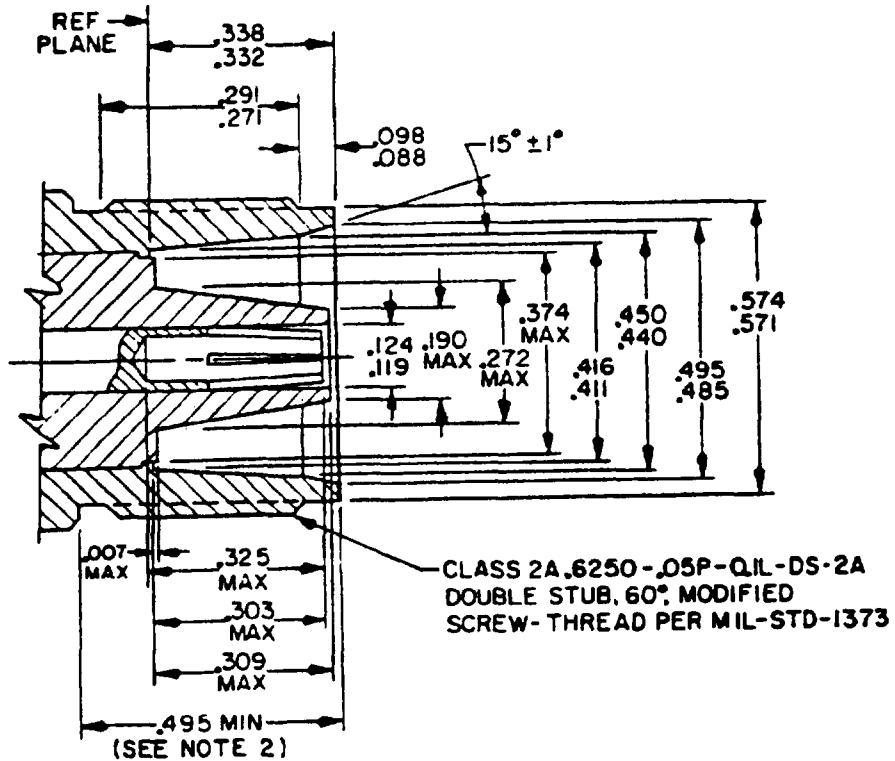

Inches	mm	Inches	mm	Inches	mm
.007	0.18	.291	7.39	.416	10.56
.088	2.24	.303	7.70	.440	11.18
.098	2.50	.309	7.85	.450	11.43
.119	3.02	.325	8.26	.485	12.32
.124	3.15	.332	8.43	.495	12.57
.190	4.83	.338	8.59	.571	14.50
.271	6.88	.374	9.50	.574	14.58
.272	6.91	.411	10.44	.6250	15.88

NOTES:

1. This interface shall meet the gauge requirements as specified in MIL-C-39012/85.
2. Clearance for mating connector coupling nut.

FIGURE 308-2. Interface, series OSC, socket contact.

## MIL-STD-348A

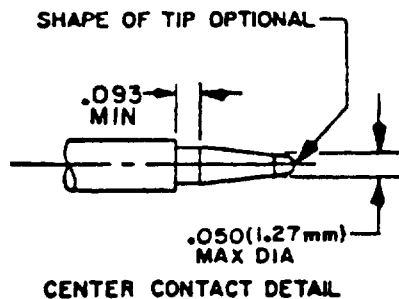
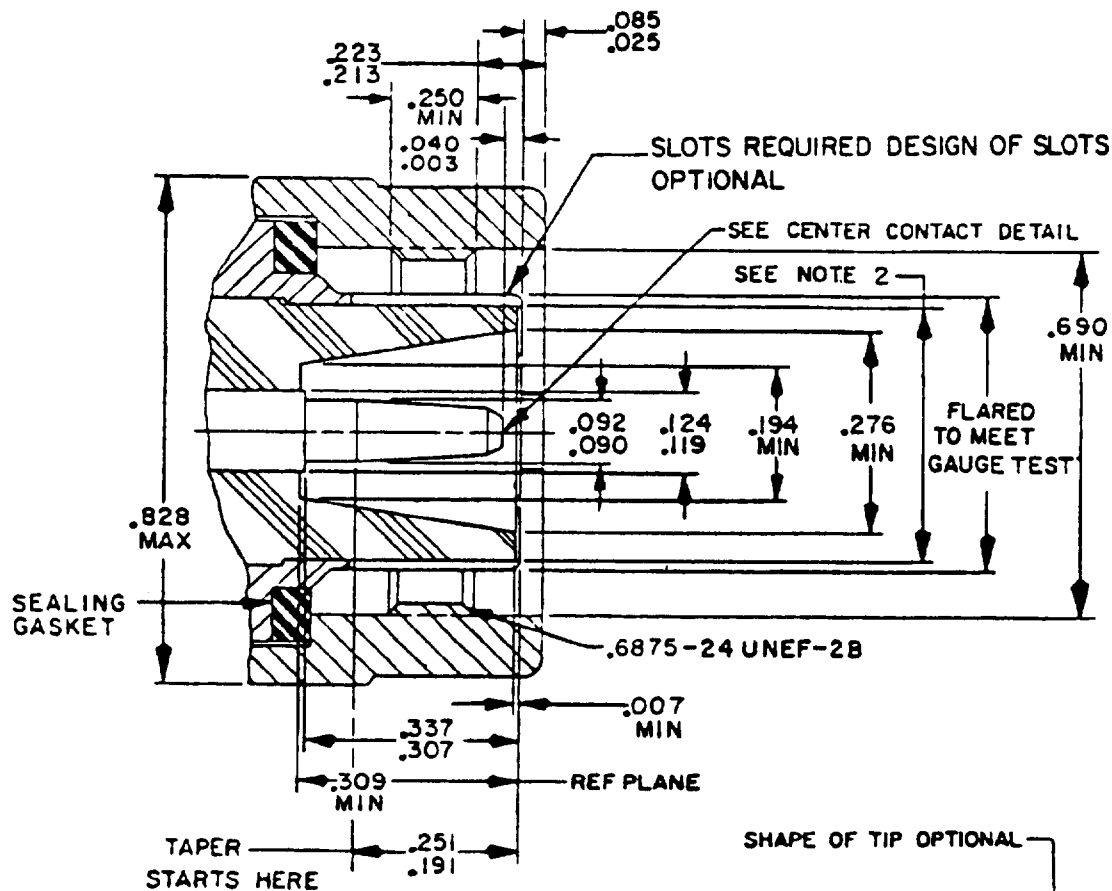

Inches	mm	Inches	mm
.003	0.08	.194	4.93
.007	0.18	.213	5.41
.025	0.64	.223	5.66
.040	1.02	.250	6.35
.050	1.27	.251	6.38
.085	2.16	.276	7.01
.090	2.29	.307	7.80
.092	2.34	.309	7.85
.093	2.36	.337	8.56
.119	3.02	.6875	17.460
.124	3.23	.690	17.53
.191	4.85	.828	21.03

## NOTES:

1. This interface shall meet the gauge requirements as specified in MIL-C-39012/35.
2. The I.D. of outer contact when inserted into a .411 (10.44 mm) maximum ring gauge shall be .377 (9.58 mm) minimum.

FIGURE 309-1. Interface, series SC, pin contact.

MIL-STD-348A

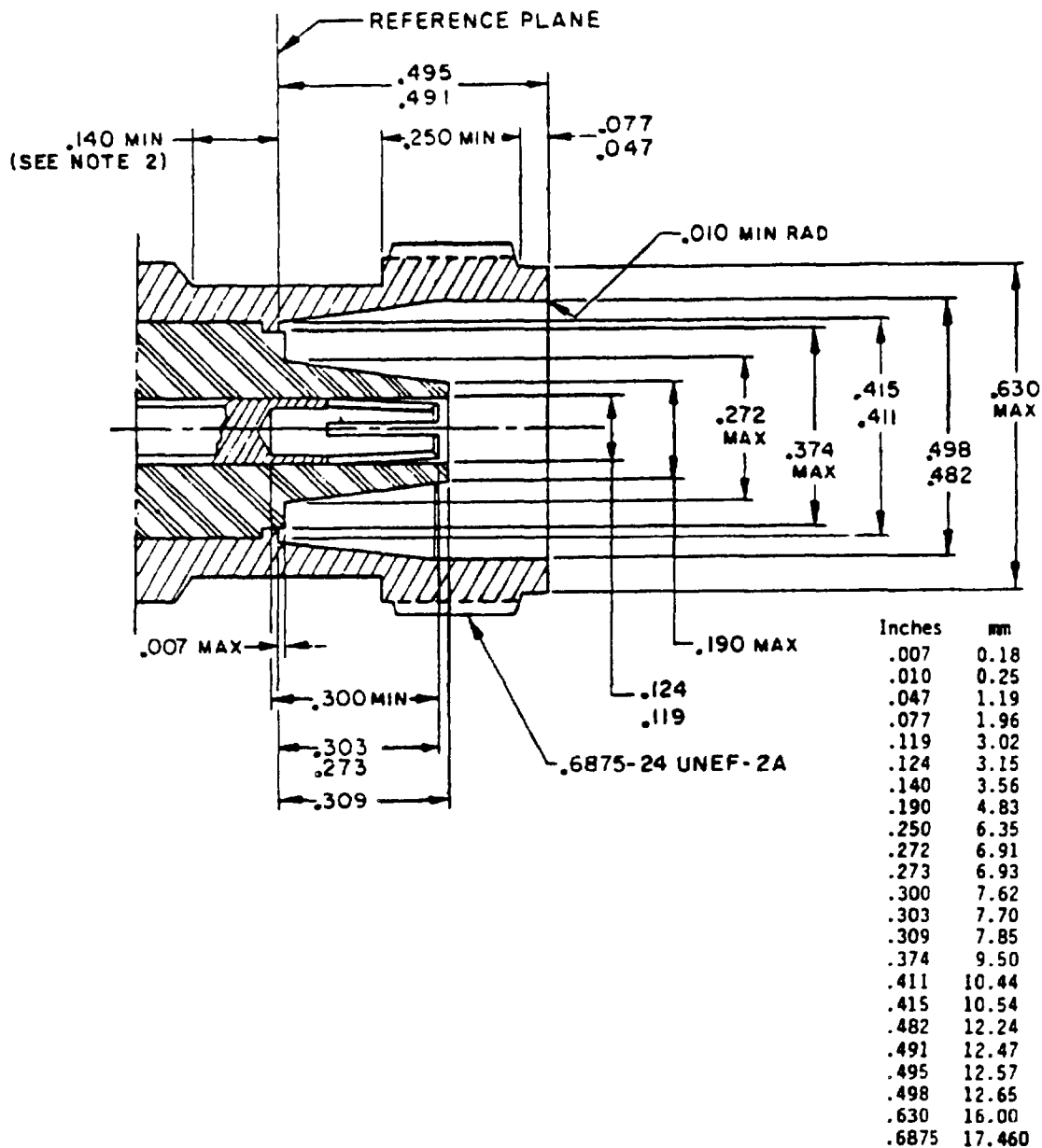

## NOTES:

1. This interface shall meet the gauge requirements as specified in MIL-C-39012/40.
2. Clearance for mating connector coupling nut.

FIGURE 309-2. Interface, series SC, socket contact.

MIL-STD-348A

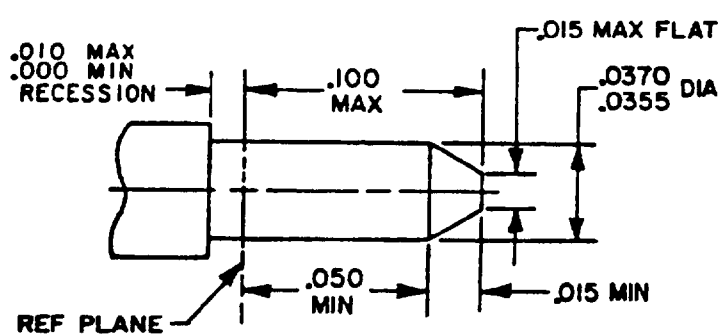
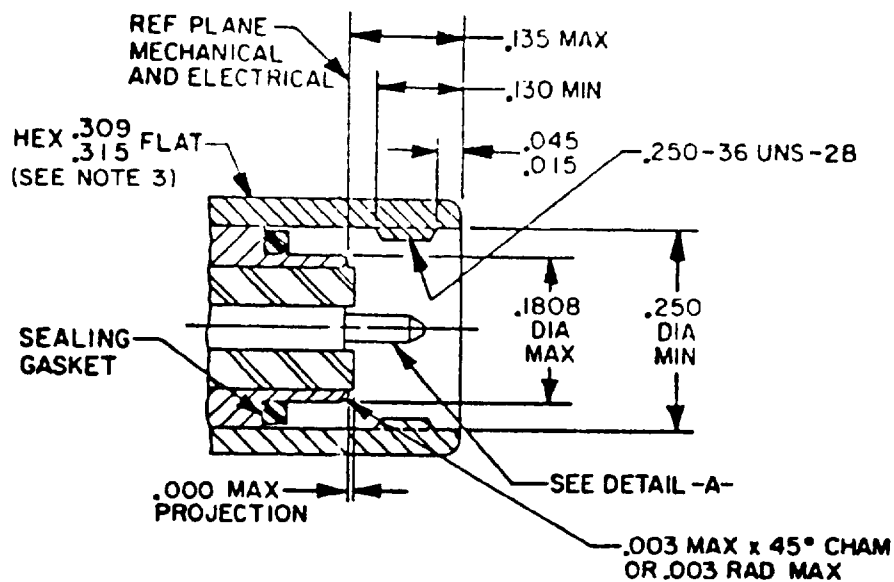

Inches	mm
.003	0.08
.010	0.25
.015	0.38
.0355	0.900
.0370	0.940
.045	1.14
.050	1.27
.100	2.54
.130	3.30
.135	3.43
.1808	4.590
.250	6.35
.309	7.85
.315	8.00

DETAIL -A-

## NOTES:

1. This interface shall meet the gauge requirements as specified in MIL-C-39012/79.
2. Connector interfaces (after connector mating) shall be kept free from dust and moisture.
3. May extend throughout the full length of the coupling nut.

FIGURE 310-1. Interface, series SMA, pin contact.



MIL-STD-348A

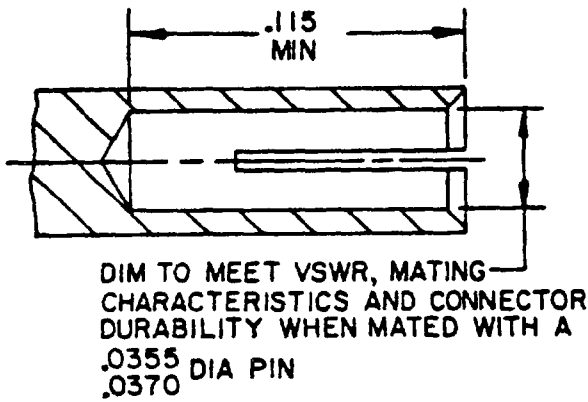
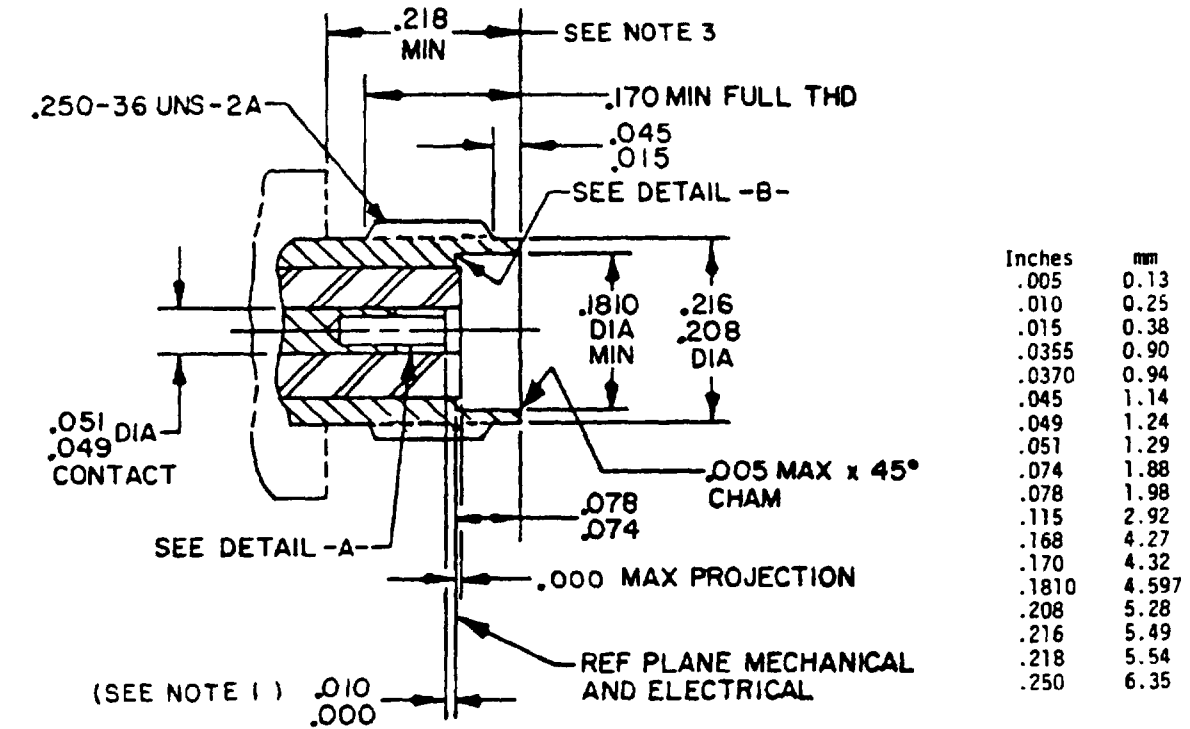

DETAIL -A-

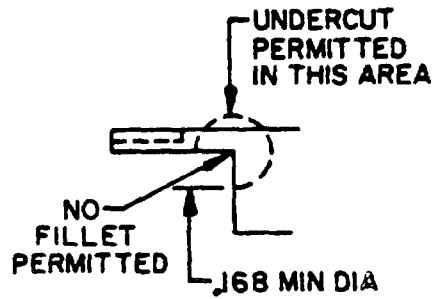

DETAIL -B-

NOTES:

1. A .030 inch (0.76 mm) maximum contact recession is permissible for thick wall designs only.
2. This interface shall meet the gauge requirements as specified in MIL-C-39012/83.
3. Clearance for mating connector coupling nut.

FIGURE 310-2. Interface, series SMA, socket contact.

## MIL-STD-348A

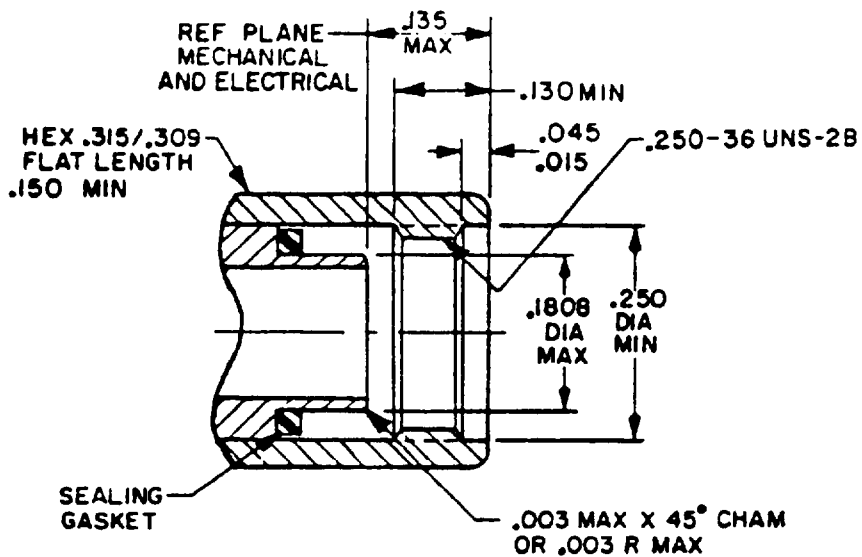

Inches	mm
.003	0.08
.015	0.38
.045	1.14
.130	3.30
.135	3.43
.150	3.81
.1808	4.59
.250	6.35
.309	7.85
.315	8.00

## NOTES:

1. This interface shall meet the gauge requirements as specified in MIL-C-39012/92.
2. Reference MIL-C-39012/92 for cable stripping dimensions.

FIGURE 310-3. Interface, series SMA, no contact.

MIL-STD-348A

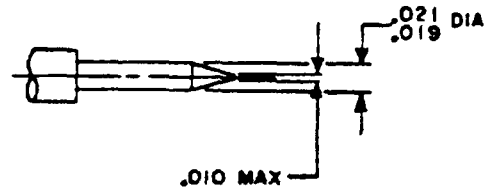
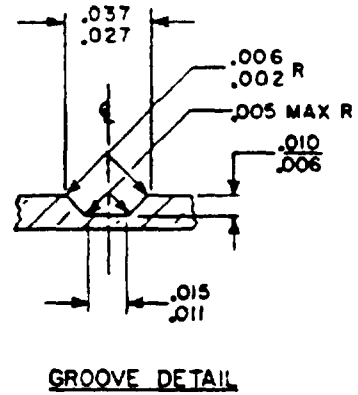
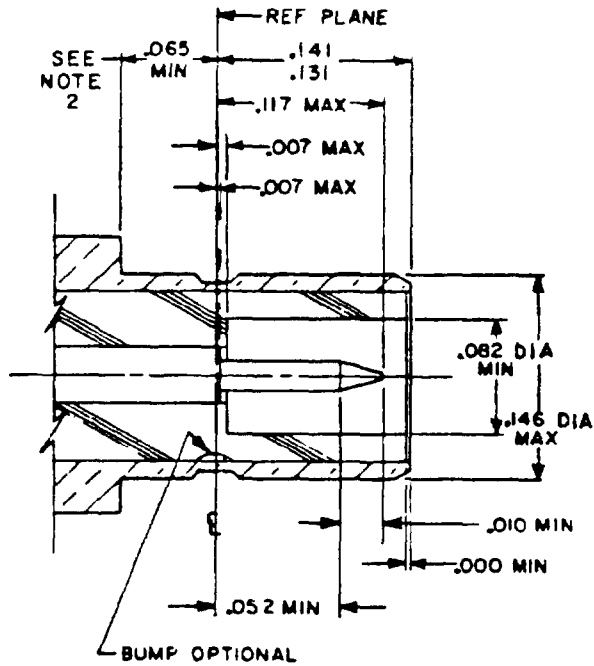

Inches	mm	Inches	mm
.002	0.05	.027	0.69
.005	0.13	.037	0.94
.006	0.15	.052	1.32
.007	0.18	.065	1.65
.010	0.25	.082	2.08
.011	0.28	.117	2.97
.015	0.38	.131	3.33
.019	0.48	.141	3.58
.021	0.53	.146	3.71

NOTES:

1. This interface shall meet the gauge requirements as specified in MIL-C-39012/68.
2. Clearance for mating connector coupling nut.

FIGURE 311-1. Interface, series SMB, pin contact.

## MIL-STD-348A

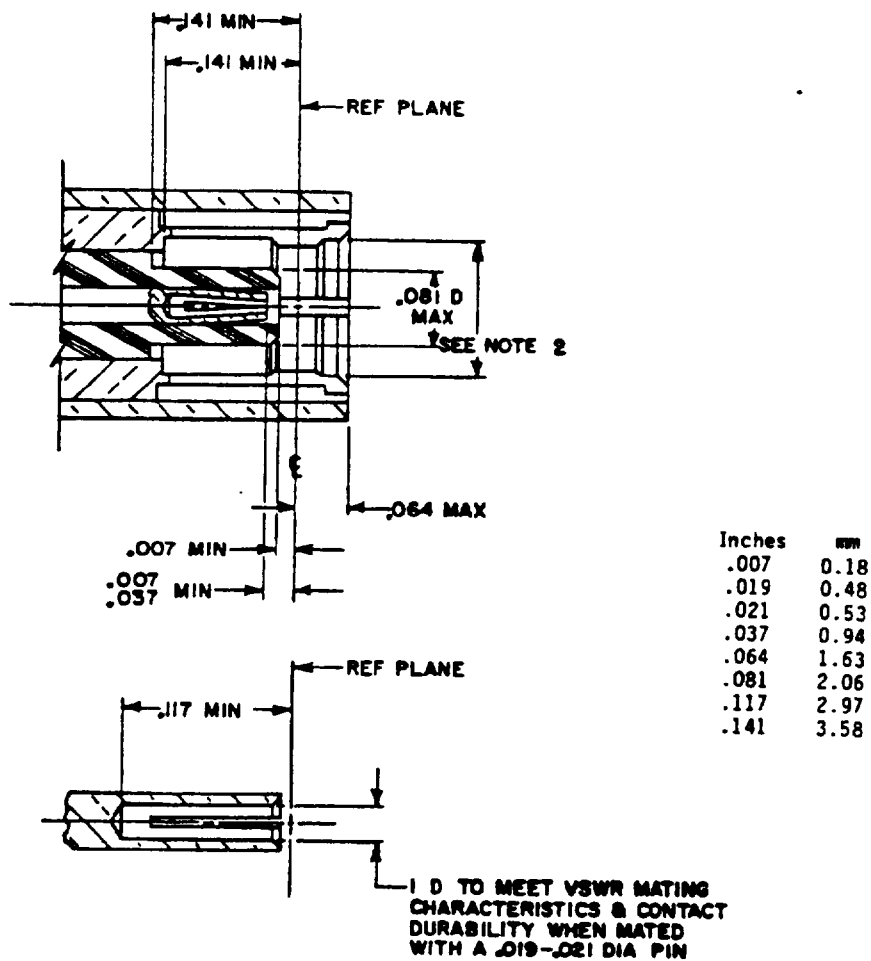

## NOTES:

1. Method of slotting of inner contact optional.
2. Must meet the longitudinal force requirements of force to engage and disengage when mated with its mating gauge.
3. This interface shall meet the gauge requirements as specified in MIL-C-39012/67.

FIGURE 311-2. Interface, series SMB, socket contact.

## MIL-STD-348A

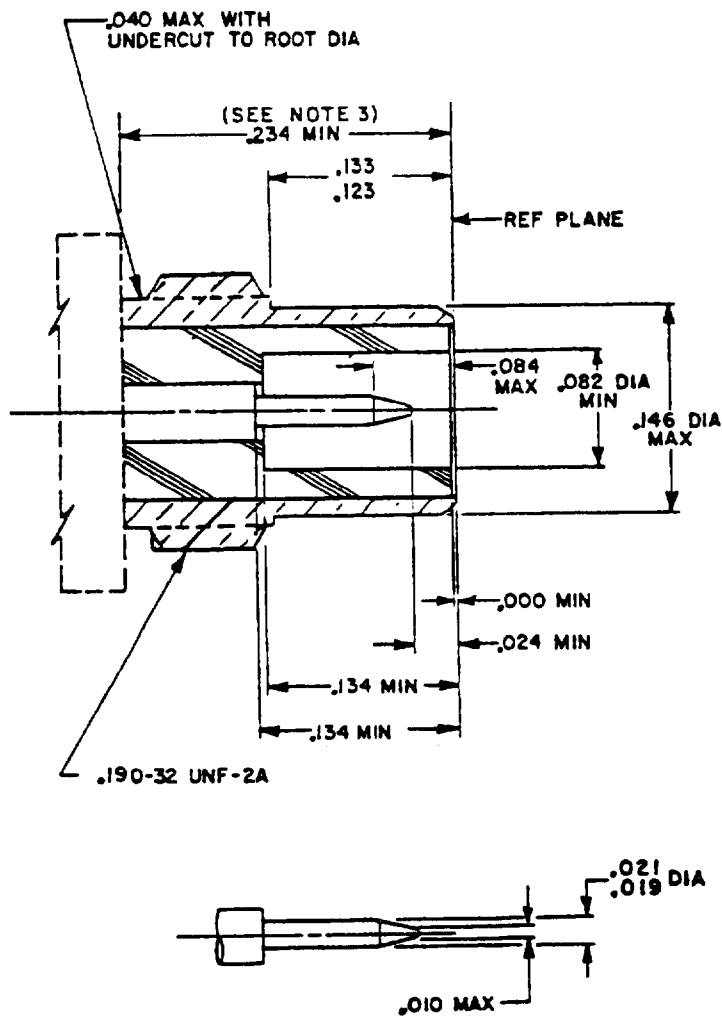

## NOTES:

1. This interface shall meet the gauge requirements as specified in MIL-C-39012/74.
2. Thread gauge must go  $.234$  (5.94 mm) minimum from reference plane.
3. Clearance for mating connector coupling nut.

FIGURE 312-1. Interface, series SMC, pin contact.

## MIL-STD-348A

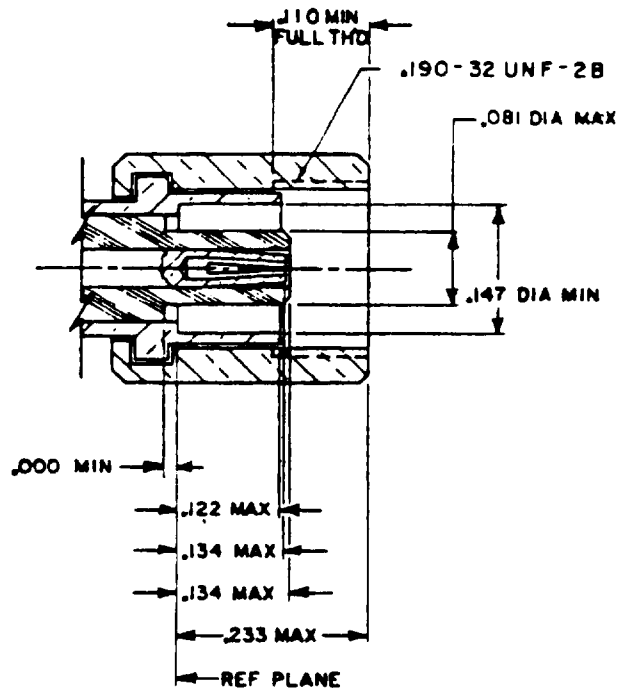

Inches	mm
.019	0.48
.021	0.53
.081	2.06
.110	2.79
.122	3.10
.134	3.40
.147	3.73
.190	4.83
.233	5.92

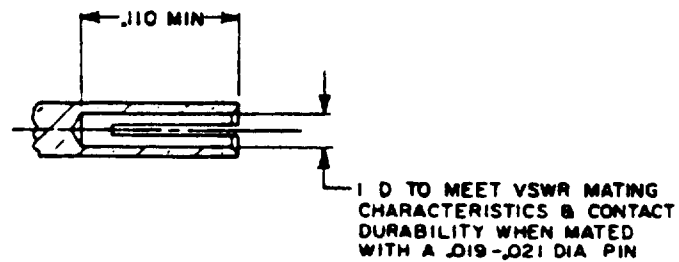

## NOTES:

1. Method of slotting of inner contact optional.
2. This interface shall meet the gauge requirements as specified in MIL-C-39012/73.

FIGURE 312-2. Interface, series SMC, socket contact.

MIL-STD-348A

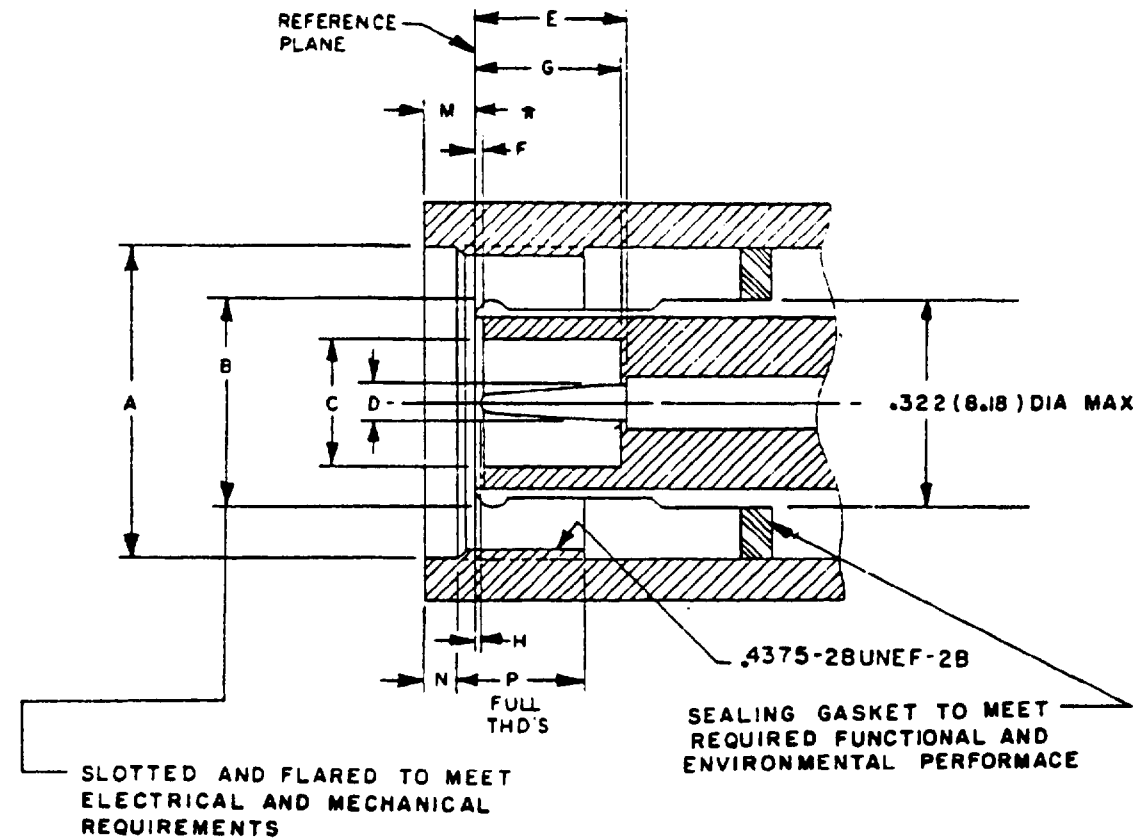

Dim Ltr	Dimensions in inches with metric equivalents (mm) in parentheses.	
	Minimum	Maximum
A	.440 (11.18)	
B	Gauge test	
C	.190 (4.83)	
D	.052 (1.32)	.054 (1.37)
E	.210 (5.33)	.230 (5.84)
F	.006 (0.15)	
G	.208 (5.28)	.228 (5.79)
H	.003 (0.08)	.040 (1.02)
J	.081 (2.06)	.087 (2.21)
K	.078 (1.98)	
M		.078 (1.98)
N	.063 (1.60)	
P	.156 (3.96)	
R		.025 (0.64)

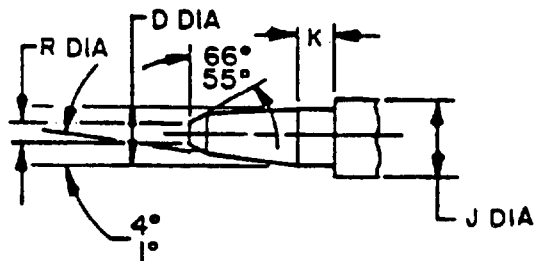

\* THIS DIMENSION SHOWS THE POSITION WITH NUT BIASED FULLY FORWARD

NOTE: This interface shall meet the gauge requirements as specified in MIL-C-39012/26.

FIGURE 313-1. Interface, series TNC, pin contact.

## MIL-STD-348A

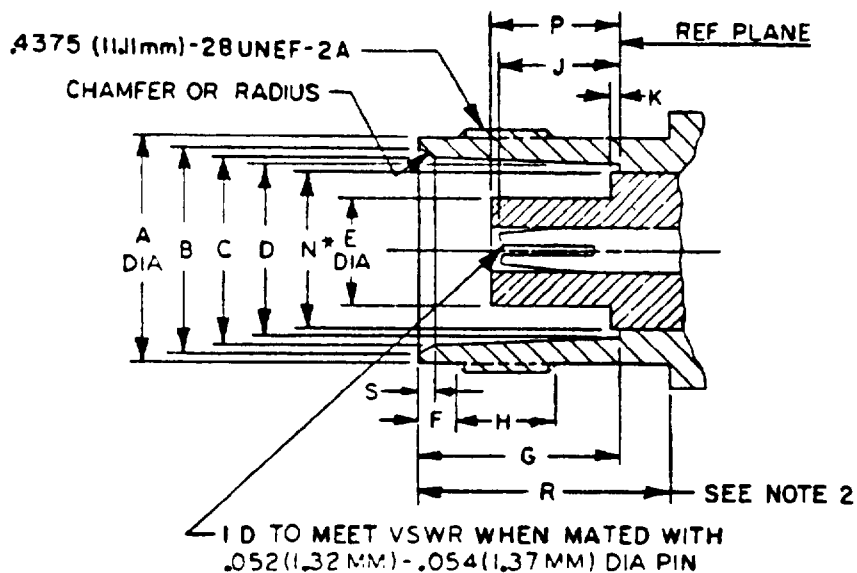

Dim Ltr	Dimensions in inches with metric equivalents (mm) in parentheses (see note)	
	Minimum	Maximum
A	.378 (9.60)	.381 (9.68)
B	.346 (8.79)	.356 (9.04)
C	.327 (8.31)	.333 (8.46)
D	.319 (8.10)	.321 (8.15)
E		.186 (4.72)
F	.068 (1.73)	.088 (2.24)
G	.327 (8.31)	.335 (8.51)
H	.187 (4.75)	
J	.186 (4.72)	.206 (5.23)
K		.006 (0.15)
L	.195 (4.95)	
M	.081 (2.06)	.087 (2.21)
N		.256 (6.50)
P	.188 (4.78)	.208 (5.28)
R	.414 (10.52)	
S	.015 (0.38)	.030 (0.76)

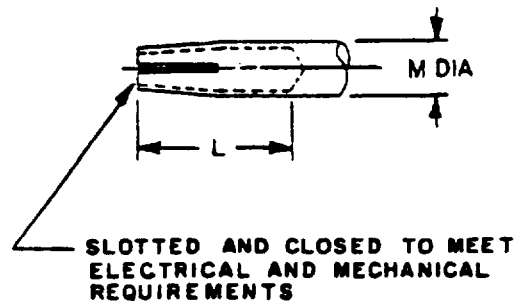

\*N dimension applies to that portion (if applicable) of the dielectric which protrudes beyond the metal shoulder (or reference plane) by dimension K.

## NOTES:

1. This interface shall meet the gauge requirements as specified in MIL-C-39012/28.
2. Clearance for mating connector coupling nut.

FIGURE 313-2. Interface, series TNC, socket contact.



MIL-STD-348A

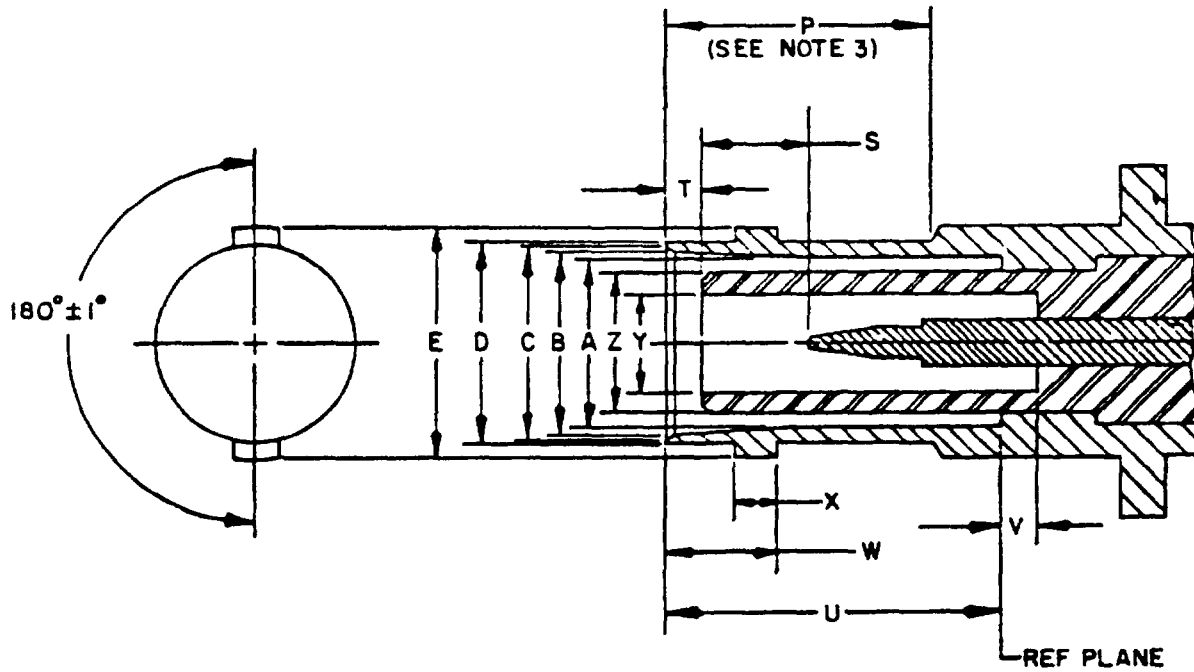

Dim Ltr	Inches		Millimeters	
	Min	Max	Min	Max
A	.319	.321	8.10	8.15
B	.328	.333	8.33	8.46
C	.347	.357	8.81	9.07
D	.378	.382	9.60	9.70
E	.432	.436	10.97	11.07
F	.207	.214	5.26	5.44
G	.130		3.30	
H	.052	.054	1.32	1.37
J	.015	.025	0.38	0.64
K	.081	.083	2.06	2.11
P	.427		10.85	
S	.188	.208	4.78	5.28
T	.061	.078	1.55	1.98
U	.626	.630	15.90	16.00
V	.064	.086	1.63	2.18
W	.204	.208	5.18	5.28
X	.075	.081	1.90	2.06
Y	.190	.196	4.83	4.98
Z		.260		6.60

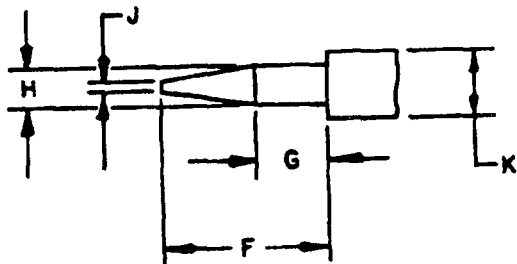

NOTES:

1. This interface shall meet the gauge requirements as specified in MIL-C-39012/107.
2. .005 (0.13 mm) flat permissible to meet dimension W.
3. Clearance for mating connector coupling nut.

FIGURE 314-1. Interface, series SHV, pin contact.

MIL-STD-348A

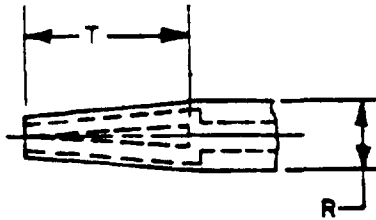
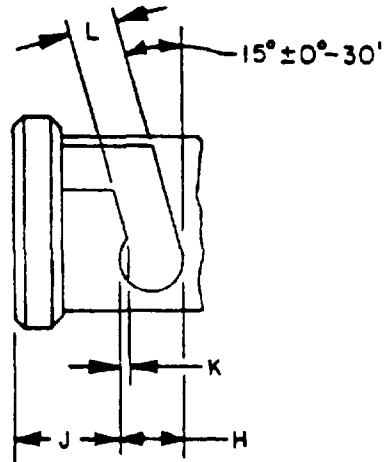
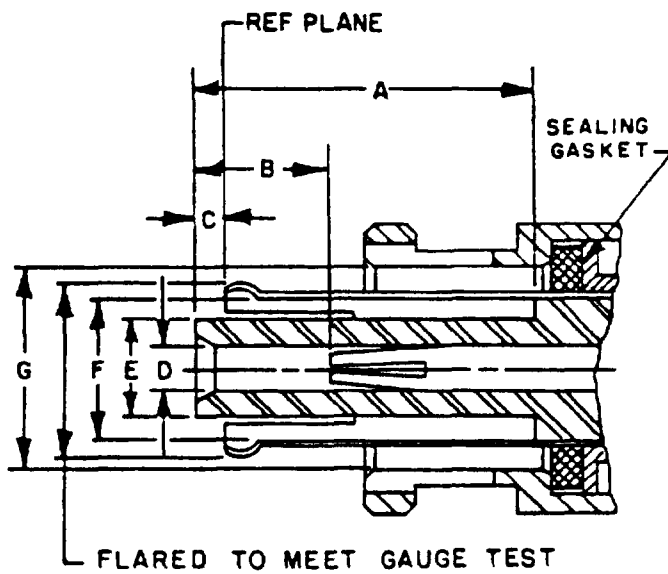

Dim Ltr	Inches		Millimeters	
	Min	Max	Min	Max
A	.628	.632	15.95	16.05
B	.238	.262	6.05	6.65
C	.046	.064	1.17	1.63
D	.002		2.08	
E	.180	.186	4.57	4.72
F	.264		6.71	
G	.385	.390	9.78	9.91
H	.124		3.15	
J	.180	.184	4.57	4.67
K	.018	.022	0.46	0.56
L	.091	.097	2.31	2.46
M	.463	.473	11.76	12.01
N	.091	.094	2.31	2.46
P	.394	.400	10.01	10.16
R	.081	.083	2.06	2.11
S	.045	.049	1.14	1.24
T	.214		5.44	

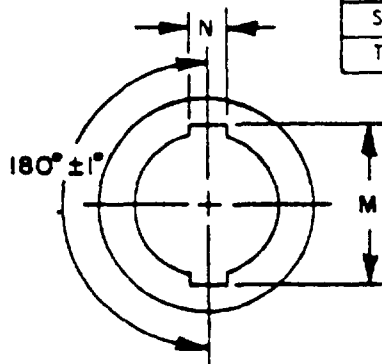
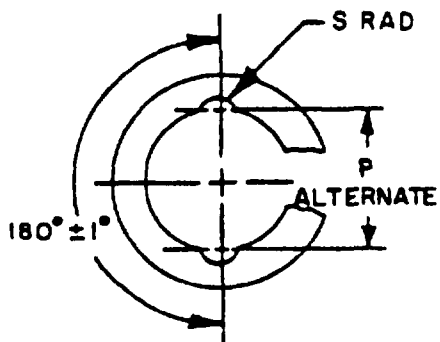

NOTE: This interface shall meet the gauge requirements as specified in MIL-C-39012/106.

FIGURE 314-2. Interface, series SHV, socket contact.

MIL-STD-348A

SECTION 300

INTERFACE DIMENSIONS FOR MIL-C-3650

FIGURE 315-1. Interface, series LC, pin contact.

## MIL-STD-348A

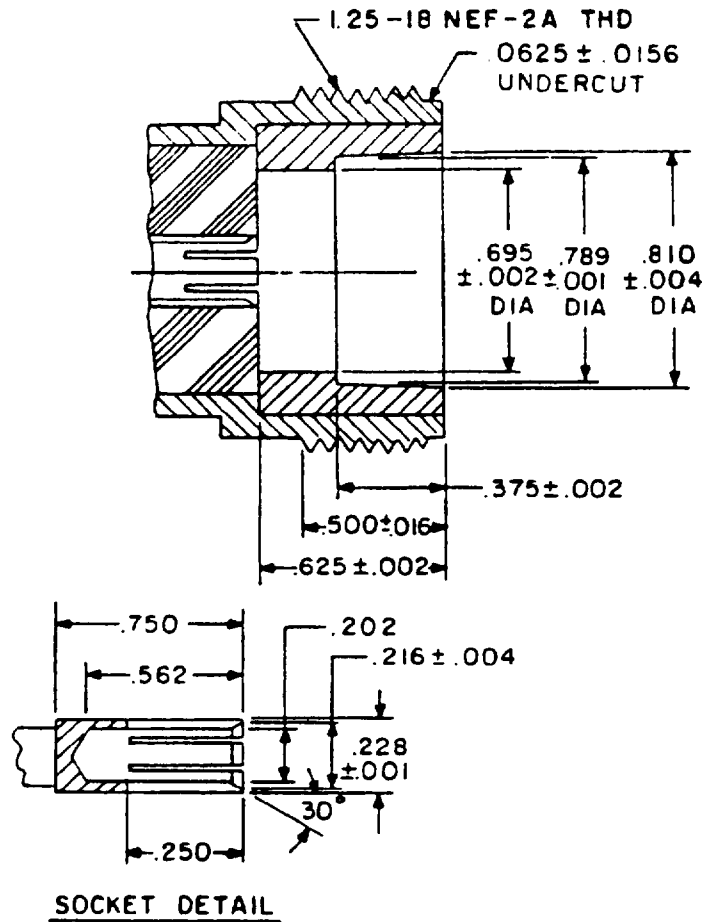

Inches	mm	Inches	mm	Inches	mm
.001	0.03	.216	5.49	.625	15.88
.002	0.05	.228	5.79	.695	17.65
.004	0.10	.250	6.35	.750	19.05
.0156	0.40	.375	9.52	.789	20.04
.016	0.41	.500	12.70	.810	20.57
.0625	1.59	.562	14.28	1.25	31.75
.202	5.13				

## NOTES:

1. Dimensions are in inches.
2. Metric equivalents are given for general information only.
3. This interface shall meet the gauge requirements as specified in MIL-C-3650.

FIGURE 315-2. Interface, series LC, socket contact.

MIL-STD-348A

SECTION 300

INTERFACE DIMENSIONS FOR MIL-C-3650

FIGURE 315-3. Interface, series LC, pin contact.

MIL-STD-348A

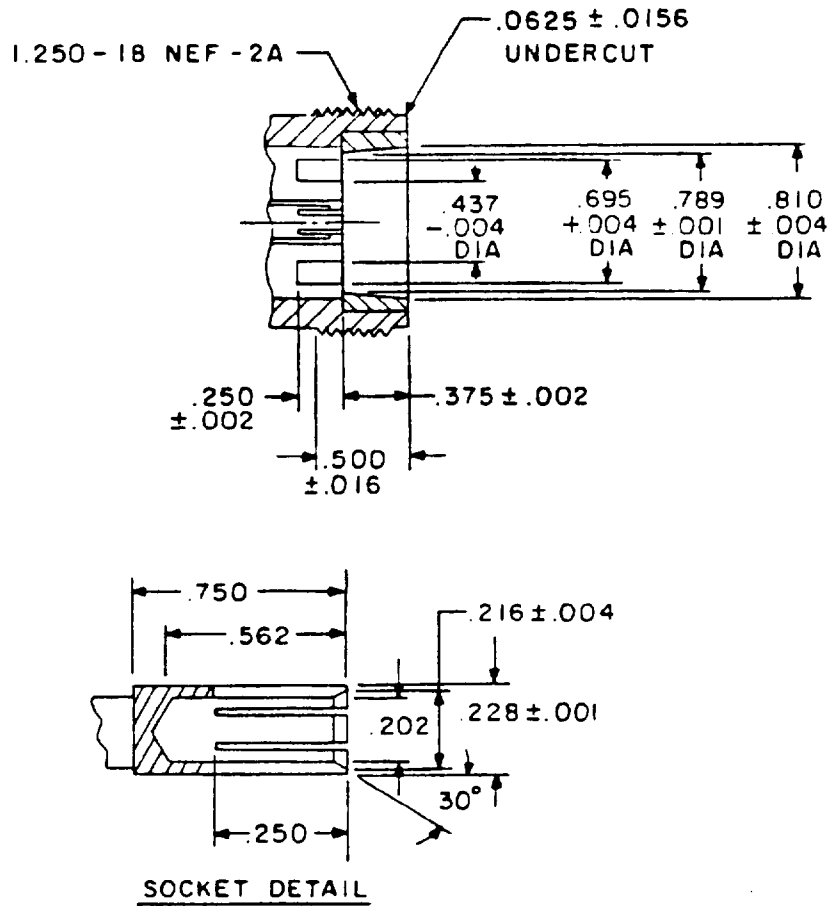

Inches	mm	Inches	mm	Inches	mm
.001	0.03	.216	5.49	.625	15.88
.002	0.05	.228	5.79	.695	17.65
.004	0.10	.250	6.35	.750	19.05
.0156	0.40	.375	9.52	.789	20.04
.016	0.41	.437	11.10	.810	20.57
.0625	1.59	.500	12.70	1.25	31.75
.202	5.13	.562	14.28		

## NOTES:

1. Dimensions are in inches.
2. Metric equivalents are given for general information only.
3. This interface shall meet the gauge requirements as specified in MIL-C-3650.

FIGURE 315-4. Interface, series LC, socket contact.

MIL-STD-348A

SECTION 300

INTERFACE DIMENSIONS FOR MIL-C-3650

FIGURE 315-5. Interface, series LC, pin contact.

## MIL-STD-348A

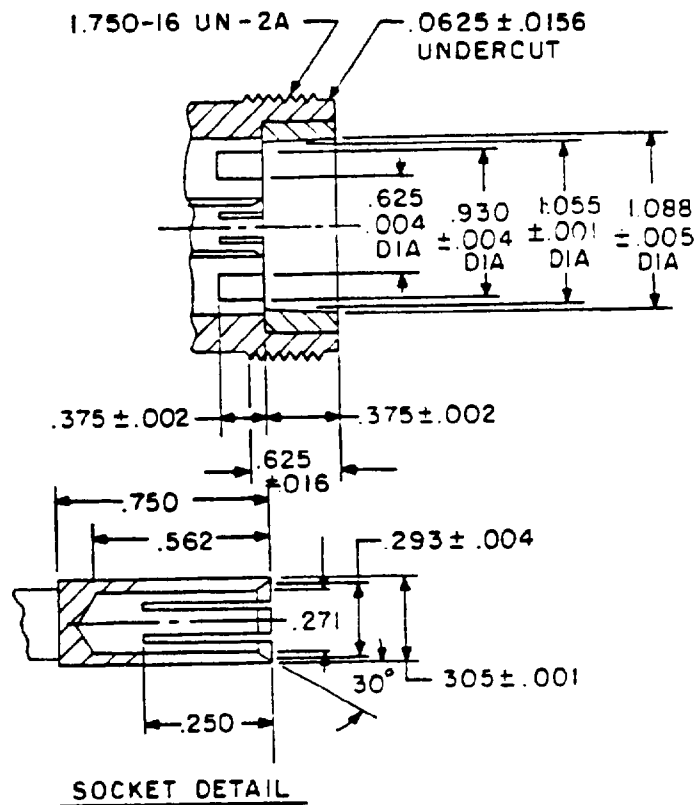

Inches	mm	Inches	mm	Inches	mm
.001	0.03	.250	6.35	.625	15.88
.002	0.05	.271	6.88	.750	19.05
.004	0.10	.293	7.44	.930	23.62
.0156	0.40	.305	7.45	1.055	26.84
.016	0.41	.375	9.52	1.088	27.64
.0625	1.59	.562	14.28	1.750	44.45

## NOTES:

1. Dimensions are in inches.
2. Metric equivalents are given for general information only.
3. This interface shall meet the gauge requirements as specified in MIL-C-3650.

FIGURE 315-6. Interface, series LC, socket contact.

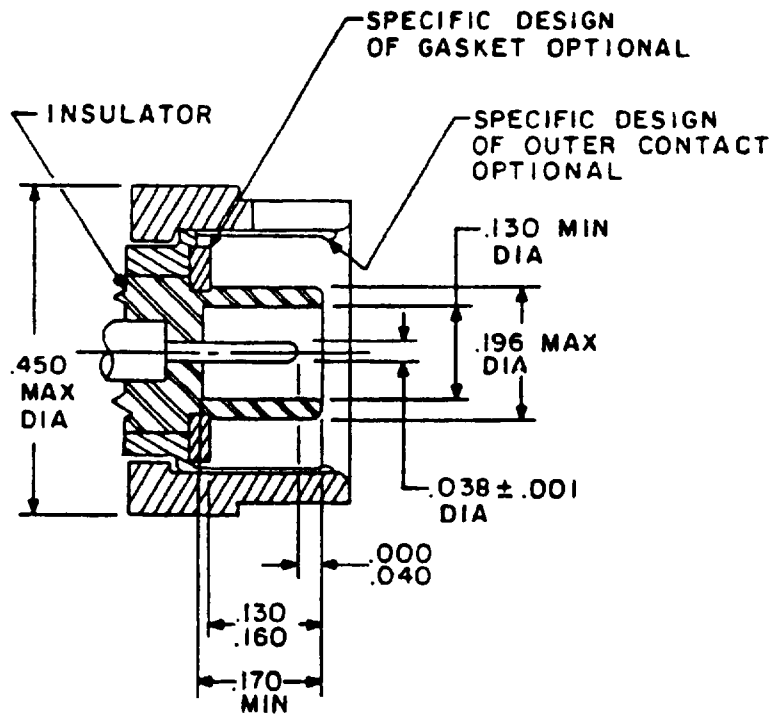

## MIL-STD-348A

PLUG WITH PIN CONTACT

Inches	mm	Inches	mm	Inches	mm
.001	0.03	.042	1.07	.170	4.32
.020	0.51	.055	1.40	.180	4.57
.027	0.69	.128	3.25	.250	6.35
.030	0.76	.130	3.30	.286	7.26
.038	0.97	.151	3.84	.450	11.43
.040	1.02	.160	4.06		

## NOTES:

1. Dimensions are in inches.
2. Metric equivalents are given for general information only.
3. This interface shall meet the gauge requirements as specified in MIL-C-25516

FIGURE 316-1. Interface, coaxial, environment resistant.

MIL-STD-348A

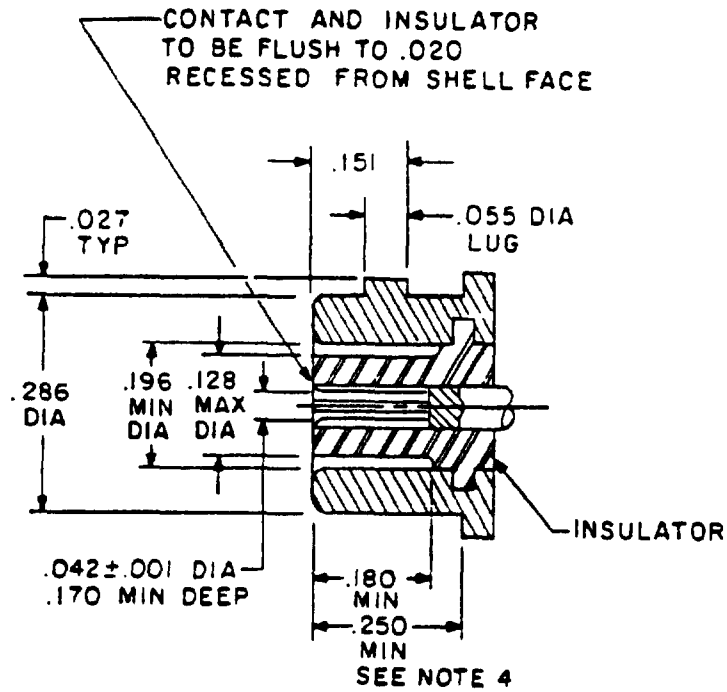

RECEPTACLE WITH SOCKET CONTACT

Inches	mm	Inches	mm	Inches	mm
.001	0.03	.055	1.40	.180	4.57
.020	0.51	.100	2.54	.196	4.98
.027	0.69	.128	3.25	.250	6.35
.038	0.97	.130	3.30	.286	7.26
.040	1.02	.151	3.84	.450	11.43
.042	1.07	.170	4.32		

NOTES:

1. Dimensions are in inches.
2. Metric equivalents are given for general information only.
3. This interface shall meet the gauge requirements as specified in MIL-C-25516
4. Clearance for mating connector coupling nut.

FIGURE 316-2. Interface, coaxial, environment resistant.

MIL-STD-348A

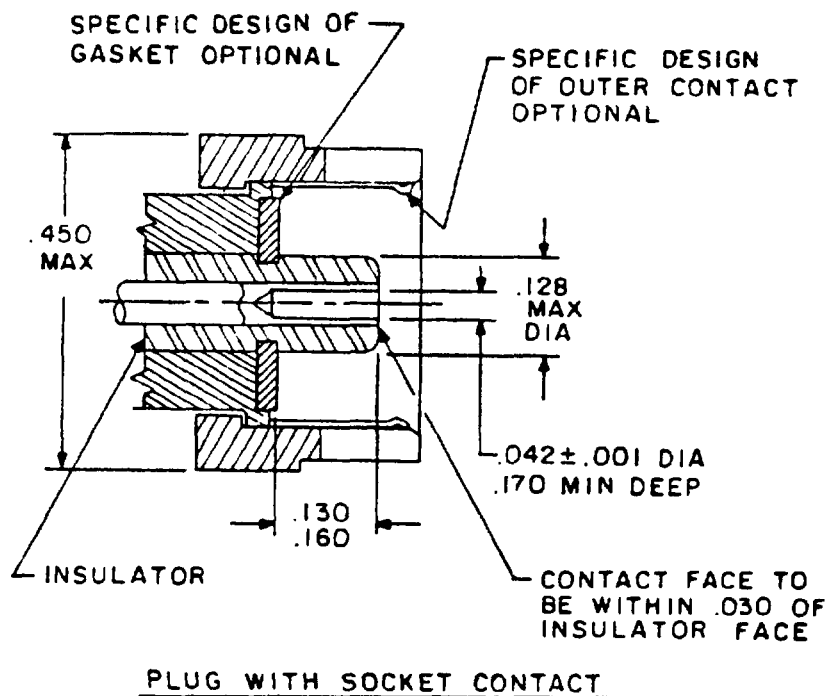

Inches	mm	Inches	mm	Inches	mm
.001	0.03	.055	1.40	.180	4.57
.020	0.51	.100	2.54	.196	4.98
.027	0.69	.128	3.25	.250	6.35
.038	0.97	.130	3.30	.286	7.26
.040	1.02	.151	3.84	.450	11.43
.042	1.07	.170	4.32		

## NOTES:

1. Dimensions are in inches.
2. Metric equivalents are given for general information only.
3. This interface shall meet the gauge requirements as specified in MIL-C-25516

FIGURE 316-3. Interface, coaxial, environment resistant.

MIL-STD-348A

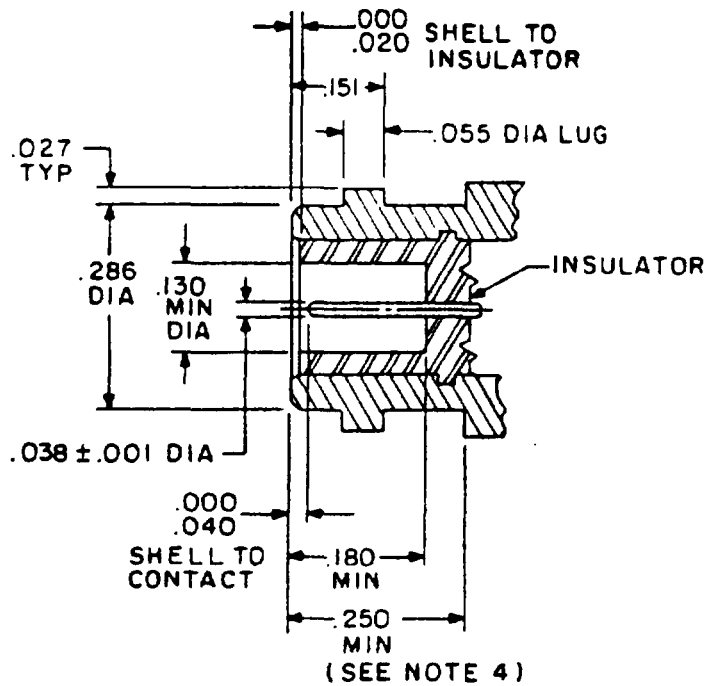

RECEPTACLE WITH PIN CONTACT

Inches	mm	Inches	mm	Inches	mm
.001	0.03	.042	1.07	.170	4.32
.020	0.51	.055	1.40	.180	4.57
.027	0.69	.128	3.25	.250	6.35
.030	0.76	.130	3.30	.286	7.26
.038	0.97	.151	3.84	.450	11.43
.040	1.02	.160	4.06		

NOTES:

1. Dimensions are in inches.
2. Metric equivalents are given for general information only.
3. This interface shall meet the gauge requirements as specified in MIL-C-25516
4. Clearance for mating connector coupling nut.

FIGURE 316-4. Interface, coaxial, environment resistant.

MIL-STD-348A

SECTION 300

INTERFACE DIMENSIONS FOR MIL-C-3643

FIGURE 315-3. Interface, series MN, pin contact.

MIL-STD-348A

SECTION 300

INTERFACE DIMENSIONS FOR MIL-C-3643

FIGURE 317-2. Interface, series MN, socket contact.

MIL-STD-348A

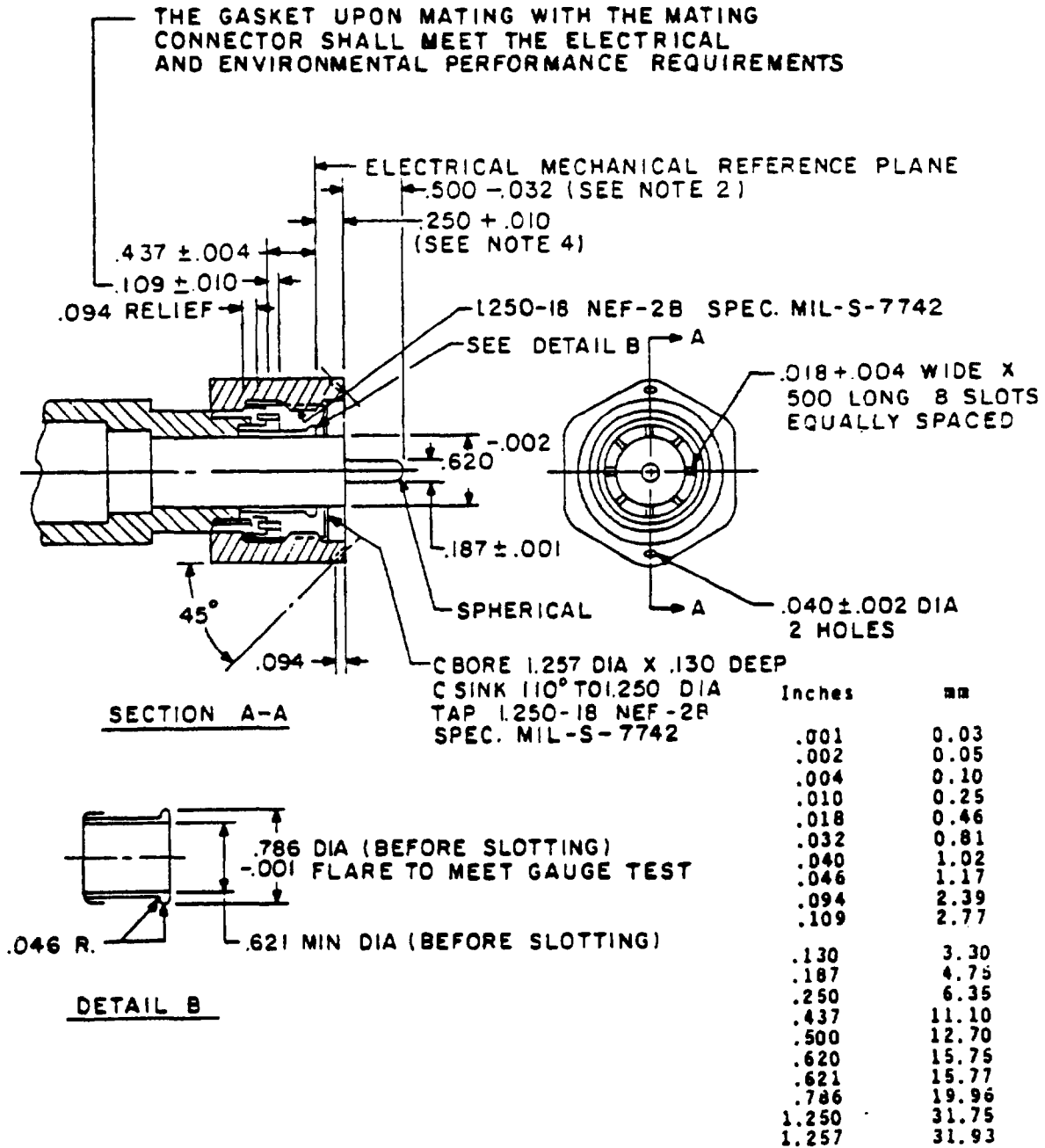

NOTES:

1. Dimensions are in inches.
2. This dimension is from the tip of the center contact to the end of the dielectric.
3. Unless otherwise specified, all tolerances shall be  $\pm .005$  inch.
4. This dimension is from the end of the outer contact to the end of the dielectric.
5. This connector shall meet the gauge requirements as specified in MIL-C-26637.

FIGURE 318-1. Interface, series LT, no contact.

MIL-STD-348A

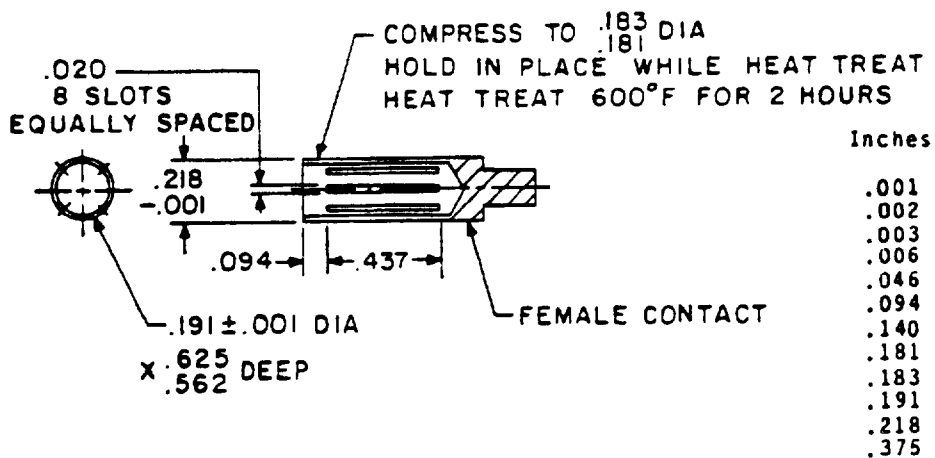
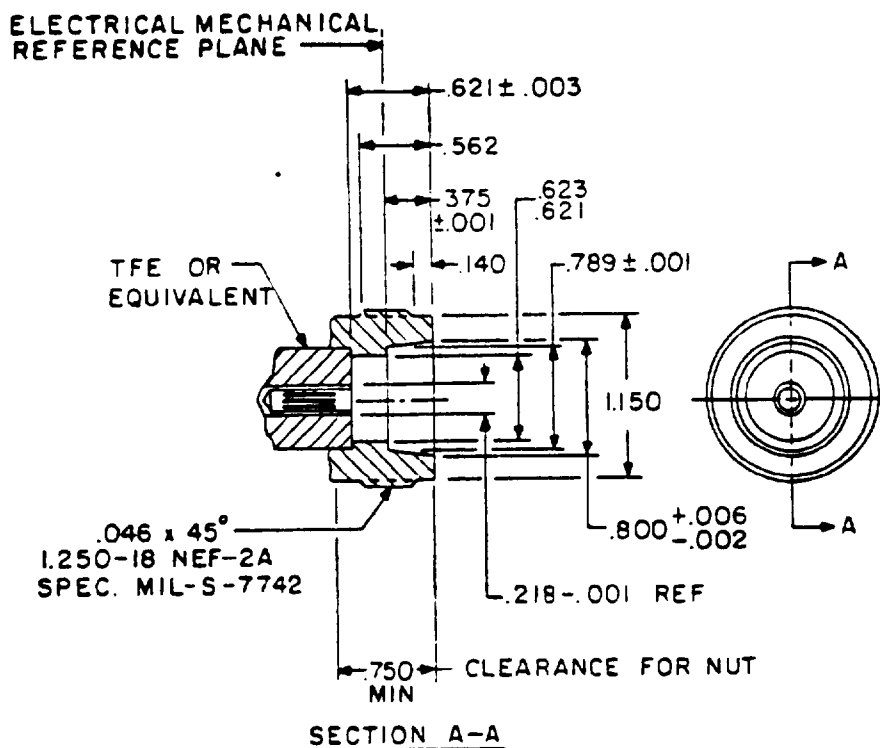

Inches	mm
.001	0.03
.002	0.05
.003	0.08
.006	0.15
.046	1.17
.094	2.39
.140	3.56
.181	4.60
.183	4.65
.191	4.85
.218	5.54
.375	9.53
.437	11.10
.562	14.27
.621	15.77
.623	15.82
.625	15.88
.750	19.05
.789	20.04
.800	20.32
1.150	29.21
1.250	31.75

NOTES:

1. Dimensions are in inches.
2. All tolerances are ±.005 unless otherwise specified.
3. This connector shall meet the gauge requirements as specified in MIL-C-26637.

FIGURE 318-2. Interface, series LT, socket contact.



## MIL-STD-348A

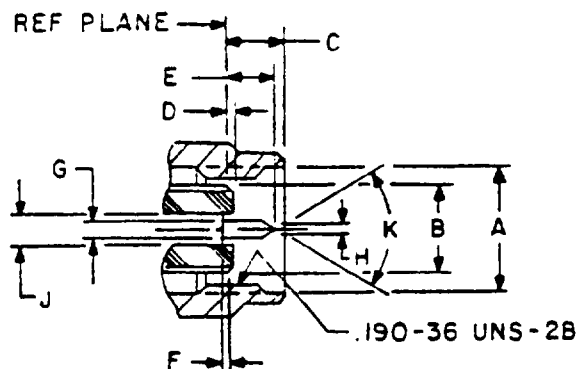

Ltr	Minimum		Maximum	
	Inches	mm*	Inches	mm*
A dia	.196	4.98	.202	5.13
B dia	.124	3.15	.1258	3.221
C	.100	2.54	.133	3.38
D	-.005	-0.13	.002	0.05
E	.060	1.27	.065	1.65
F	.000	0.00	.010	0.25
G dia	.0195	0.495	.0208	0.523
H dia	.000	0.00	.010	0.25
J dia	.0335	0.851	.0348	0.884
K	70°		95°	

## NOTES:

1. Dimensions are in inches.
2. Metric equivalents are given for general information only.

FIGURE 319-1. Interface, series SSMA, pin contact.

## MIL-STD-348A

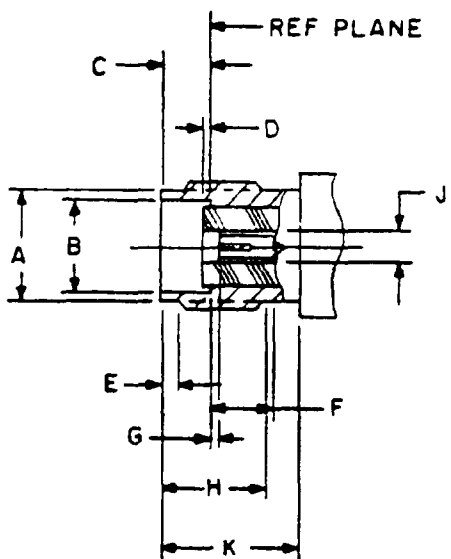

(SEE NOTE 3)

Ltr	Inches		Millimeters	
	Min	Max	Min	Max
A	.153	3.89	.160	4.06
B	.127	3.23	.130	3.30
C	.075	1.90	.077	1.96
D	-.005	-0.13	.002	0.05
E	.020	0.51	.040	1.02
F	.115	2.92	---	---
G	.000	0.00	.010	0.25
H	.190	4.83	.210	5.33
J	.0335	0.851	.0348	0.884
K	.230	5.84	---	---

## NOTES:

1. Dimensions are in inches.
2. Metric equivalents are given for general information only.
3. Clearance for mating connector coupling nut.

FIGURE 319-2. Interface, series SSMA, socket contact.

**MIL-STD-348A**

**SECTION 400  
TEST CONNECTOR**

**Interface Dimensions for MIL-C-39012, MIL-A-55339, and MIL-C-83517**

<b>Section 401</b>	<b>Series C</b>
<b>Section 402</b>	<b>Series N</b>
<b>Section 403</b>	<b>Series SC</b>
<b>Section 404</b>	<b>Series BNC</b>
<b>Section 405</b>	<b>Series SMA</b>
<b>Section 406</b>	<b>Series TNC</b>
<b>Section 407</b>	<b>Series SMB</b>
<b>Section 408</b>	<b>Series SMC</b>
<b>Section 409</b>	<b>Series QMC</b>
<b>Section 410</b>	<b>Series QSC</b>

MIL-STD-34BA

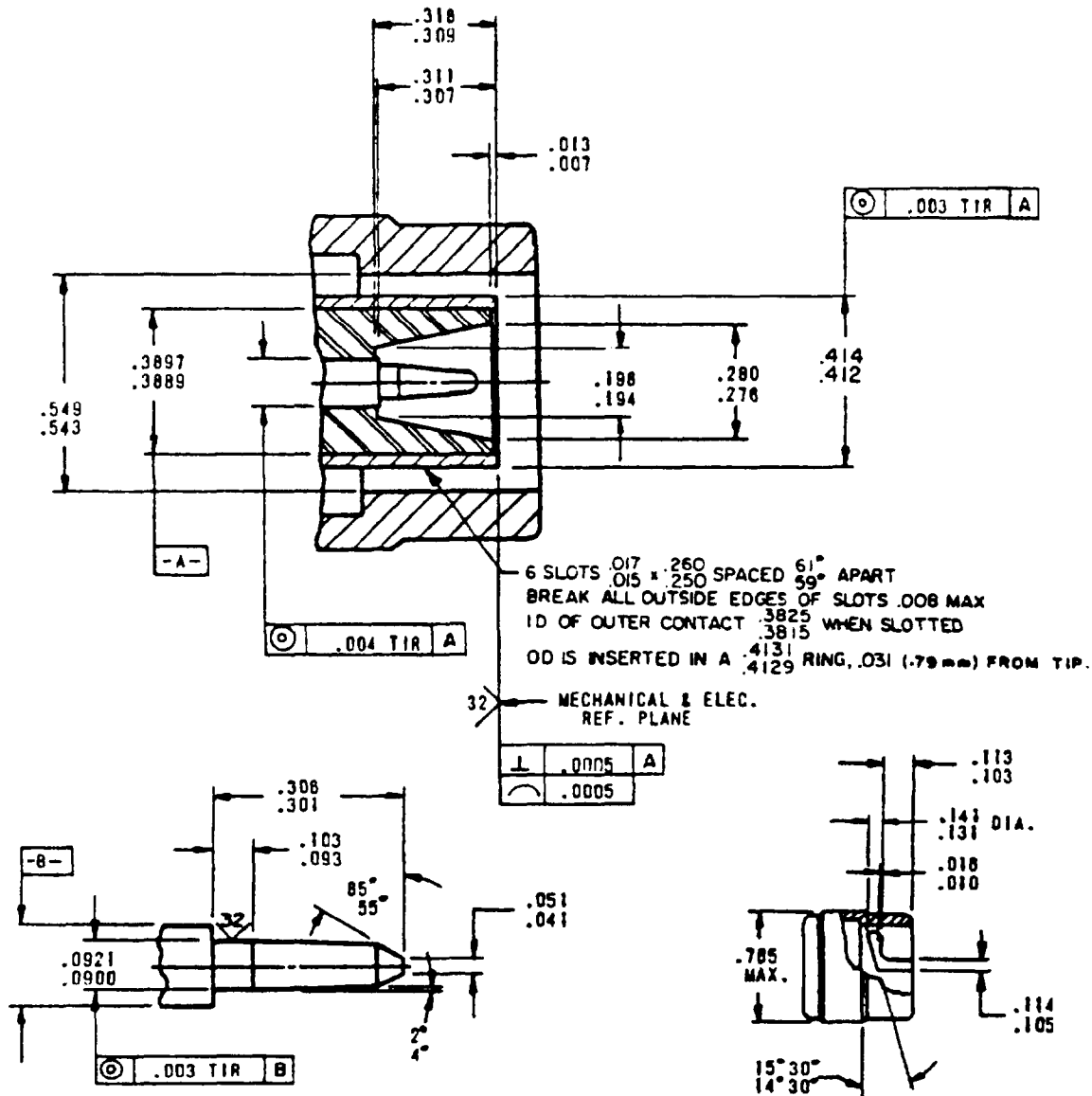

PIN DETAIL

SLOT DETAIL

Inches	mm	Inches	mm	Inches	mm	Inches	mm
.0005	0.01	.051	1.30	.198	5.03	.3815	9.69
.003	0.08	.0900	2.29	.250	6.35	.3825	9.72
.004	0.10	.0921	2.34	.260	6.60	.3889	9.88
.007	0.18	.093	2.36	.276	7.01	.3897	9.90
.008	0.20	.103	2.62	.280	7.11	.412	10.46
.010	0.25	.105	2.67	.301	7.65	.4129	10.49
.013	0.33	.113	2.87	.306	7.77	.4131	10.49
.015	0.38	.114	2.90	.307	7.80	.414	10.52
.016	0.41	.131	3.33	.309	7.85	.543	13.79
.017	0.43	.141	3.58	.311	7.90	.549	13.94
.041	1.04	.194	4.93	.318	8.08	.765	19.43

FIGURE 401-1. Interface test connector, series C, pin contact.

MIL-STD-348A

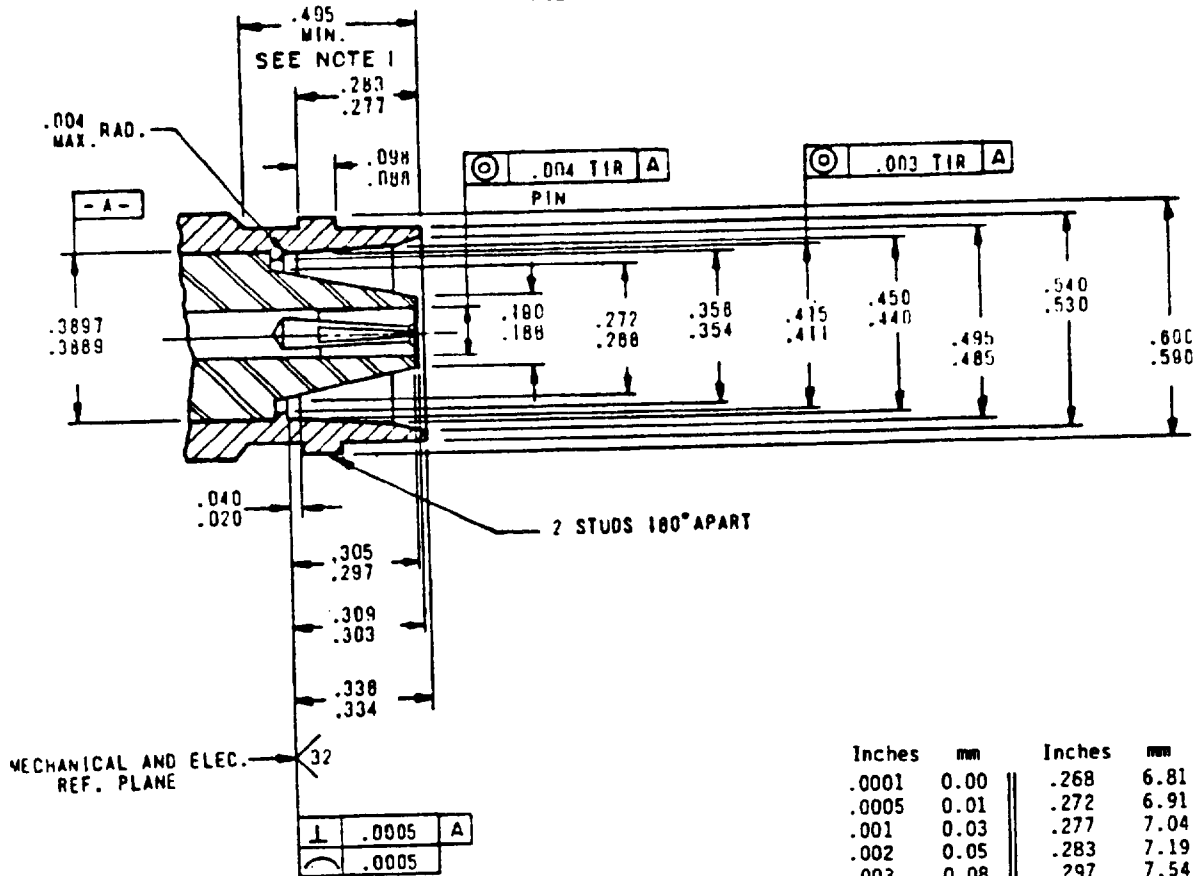

Inches	mm	Inches	mm
.0001	0.00	.268	6.81
.0005	0.01	.272	6.91
.001	0.03	.277	7.04
.002	0.05	.283	7.19
.003	0.08	.297	7.54
.004	0.10	.303	7.70
.0095	0.24	.305	7.75
.010	0.25	.306	7.77
.011	0.28	.309	7.85
.0125	0.32	.334	8.48
.020	0.51	.336	8.53
.040	1.02	.354	8.99
.087	2.21	.356	9.04
.088	2.24	.3889	9.88
.0910	2.31	.3897	9.89
.0969	2.46	.411	10.44
.098	2.49	.415	10.54
.0991	2.52	.440	11.18
.1232	3.13	.450	11.43
.1268	3.22	.485	12.32
.1314	3.34	.495	12.57
.1326	3.37	.530	13.46
.186	4.72	.540	13.72
.190	4.83	.590	14.99
.250	6.35	.600	15.24

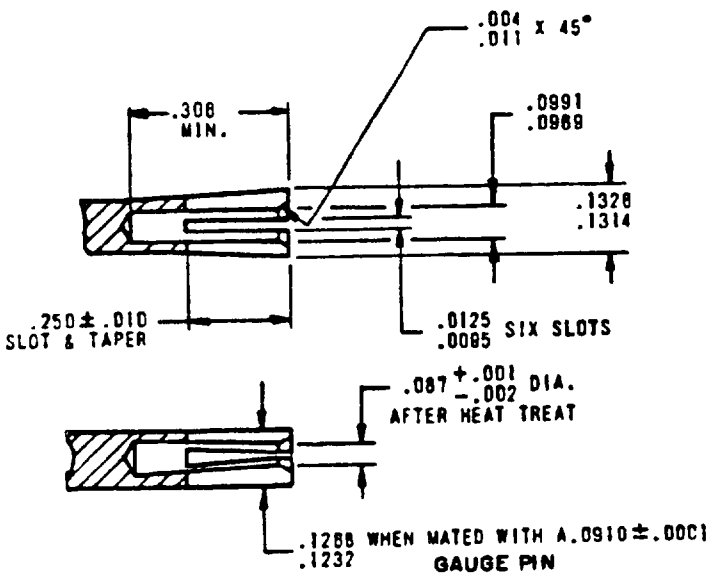

DETAIL OF INNER CONTACT

NOTE: Clearance for mating connector coupling nut.

FIGURE 401-2. Interface test connector, series C, socket contact.

MIL-STD-348A

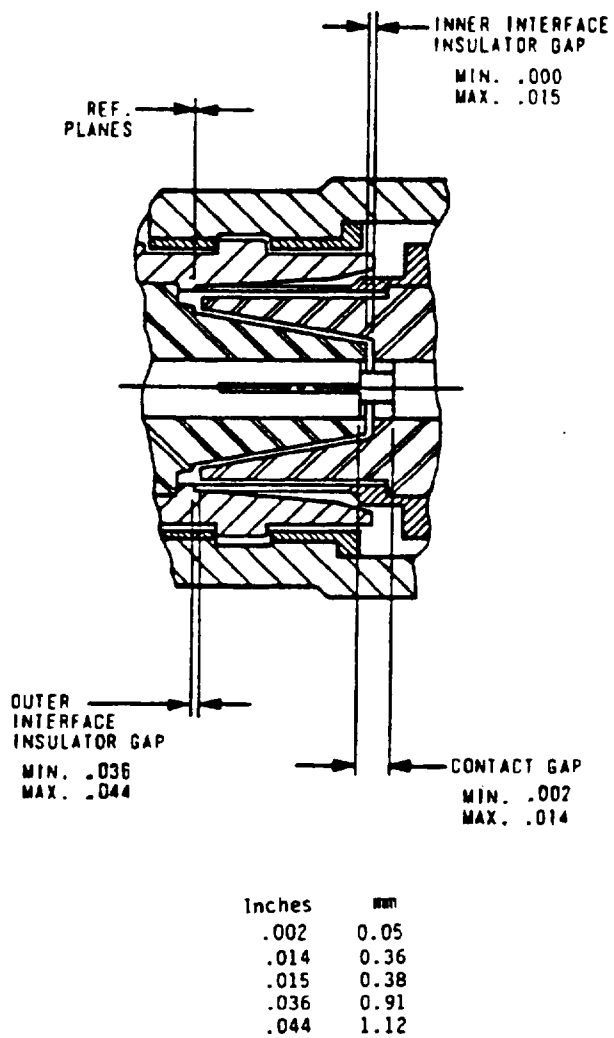

FIGURE 401-3. Interface, mated test connector, series C.

MIL-STD-348A

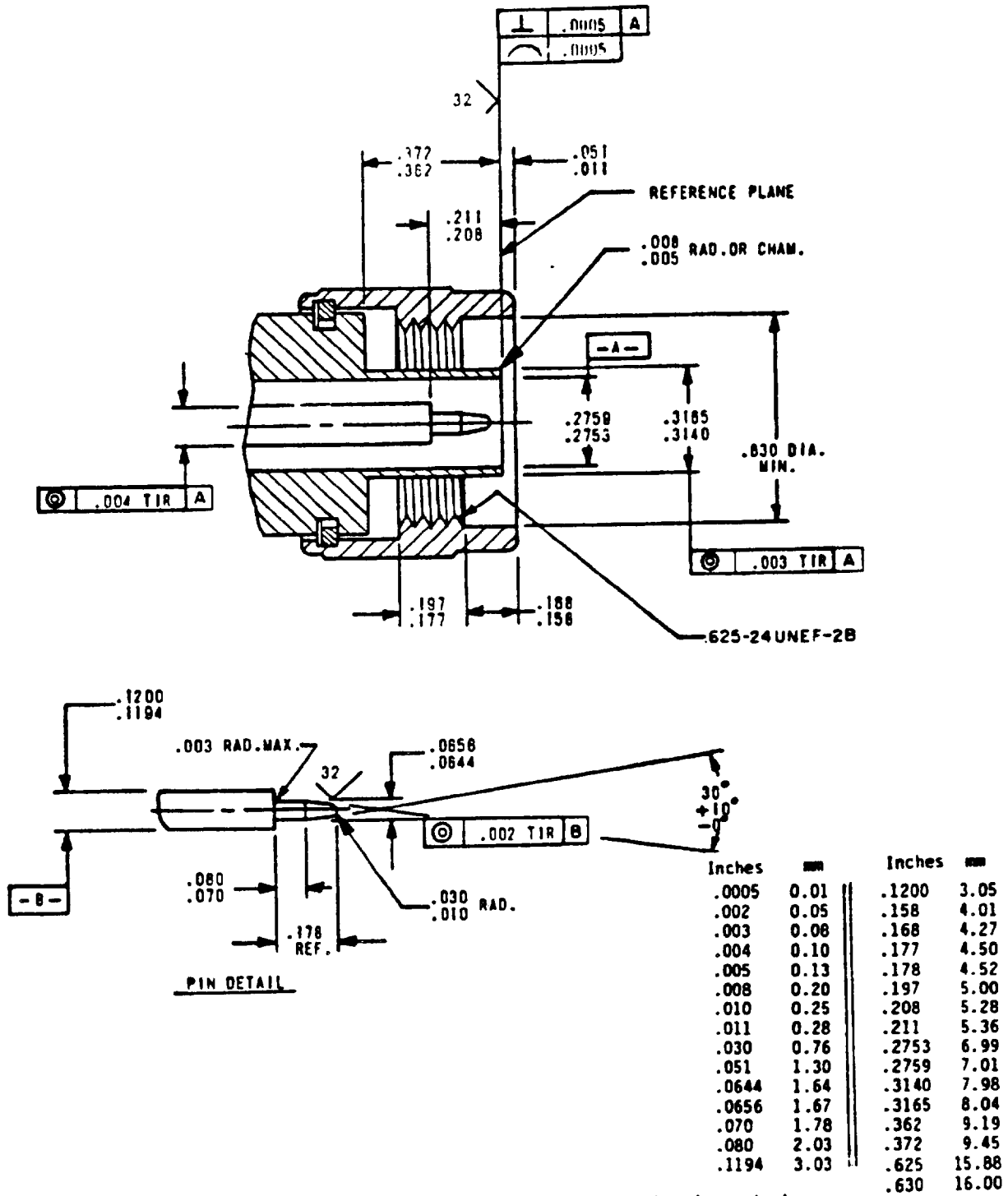
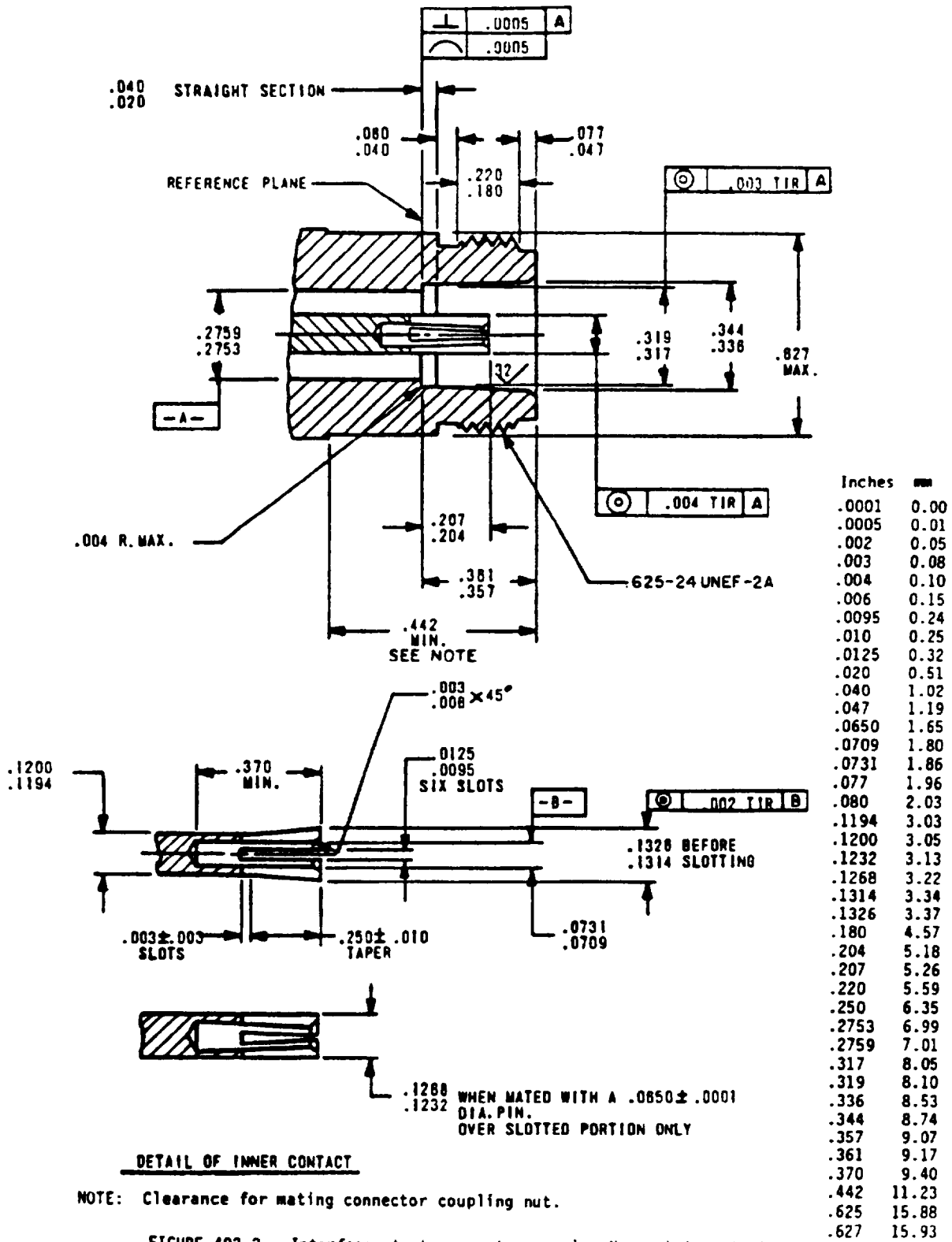

FIGURE 402-1. Interface, test connector, series M. pin contact.

MIL-STD-348A





MIL-STD-348A

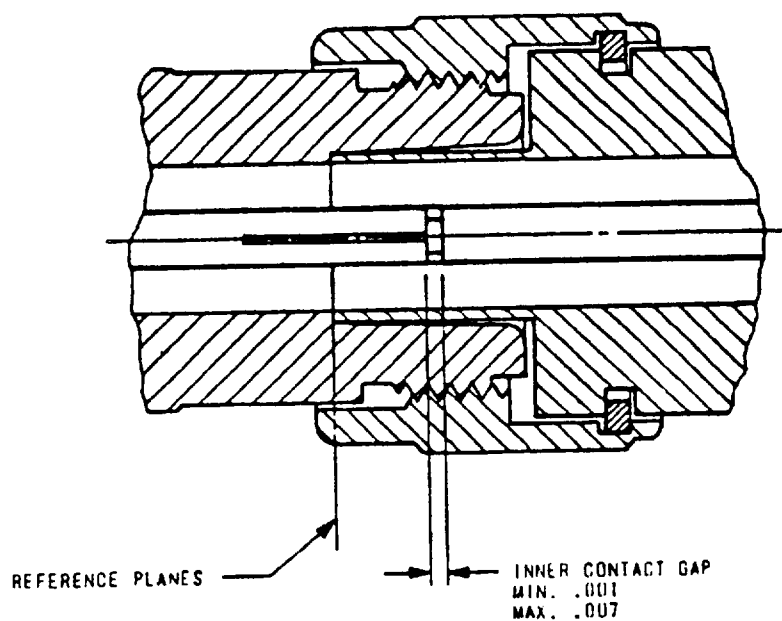

Inches	mm
.001	0.03
.007	0.18

FIGURE 402-3. Interface, mated test connector, series N.

MIL-STD-348A

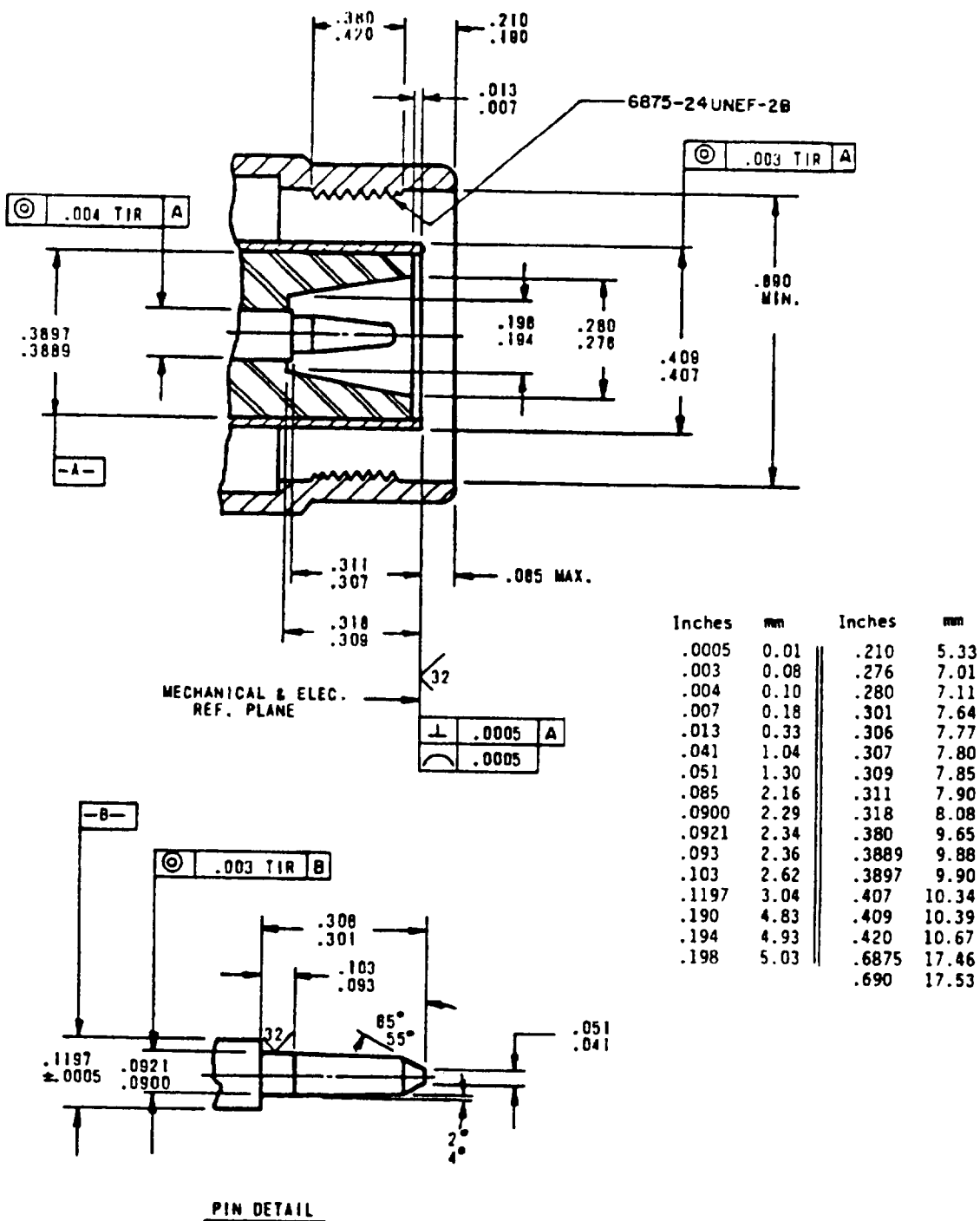

FIGURE 403-1. Interface, test connector, series SC, pin contact.

MIL-STD-348A

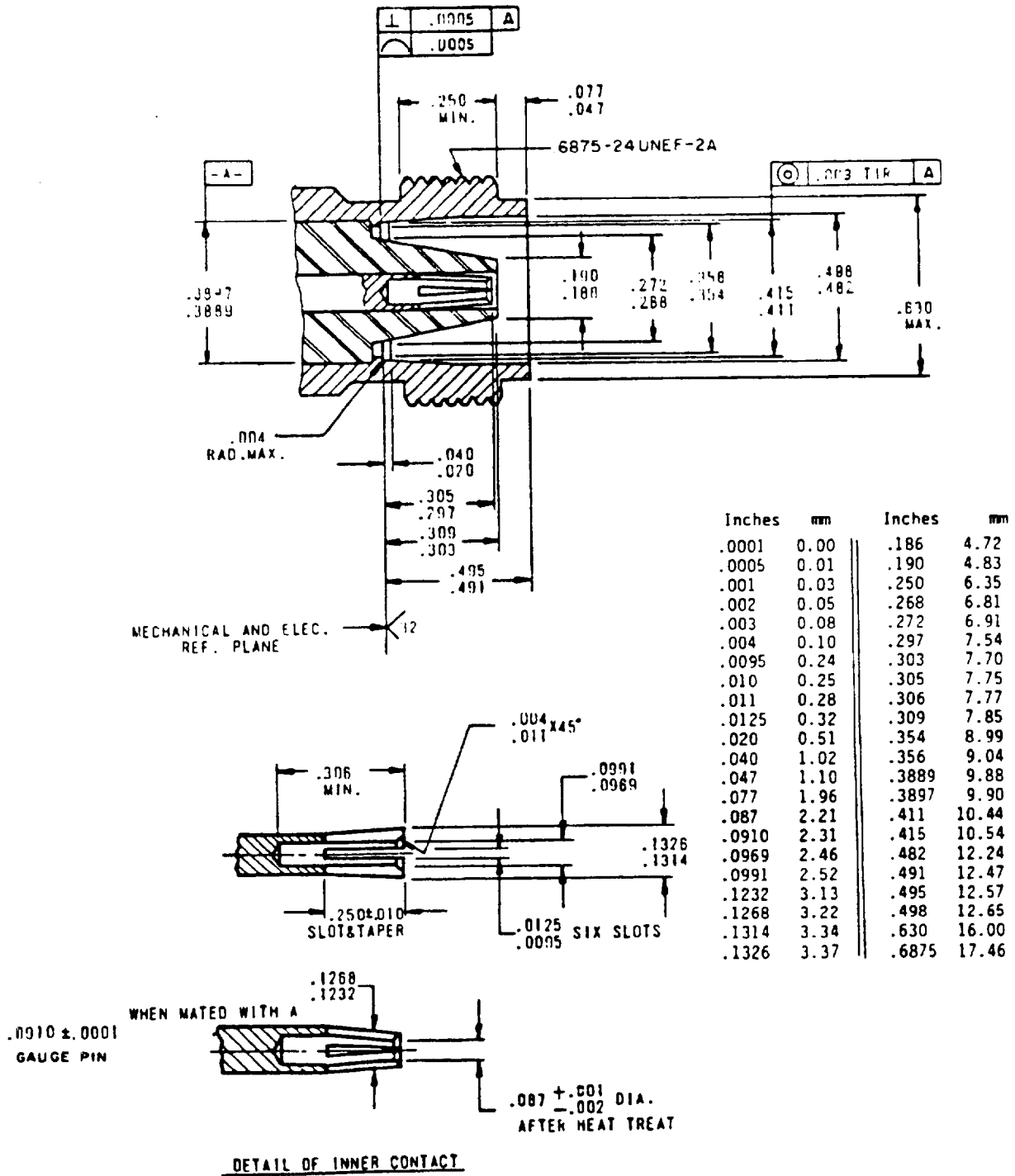
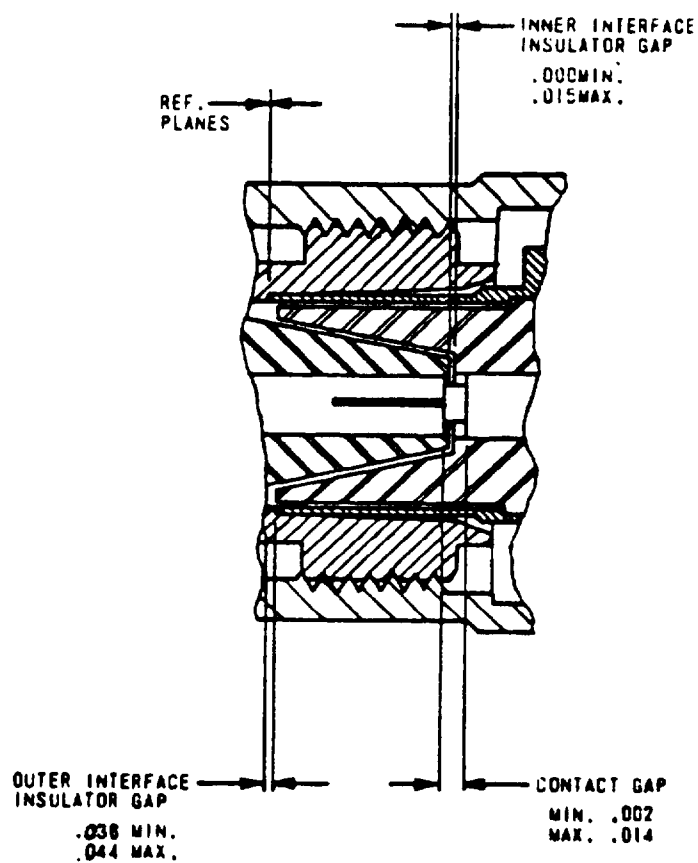

FIGURE 403-2. Interface, test connector, series SC, socket contact.

MIL-STD-348A



Inches	mm
.002	0.05
.014	0.36
.015	0.38
.036	0.91
.044	1.12

FIGURE 403-3. Interface, mated test connector, series SC.

MIL-STD-348A

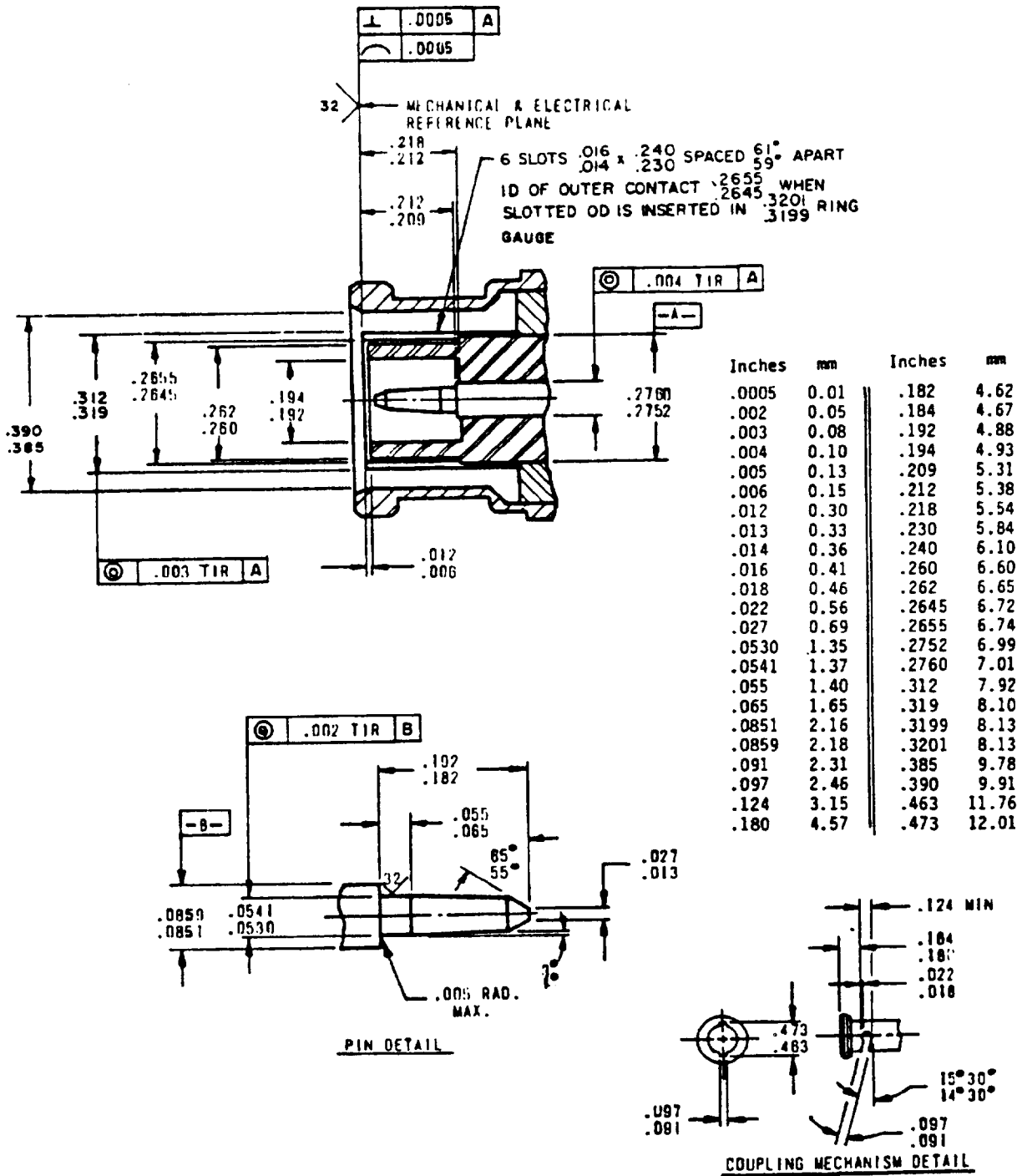

FIGURE 404-1. Interface, test connector, series BNC, pin contact.

MIL-STD-348A

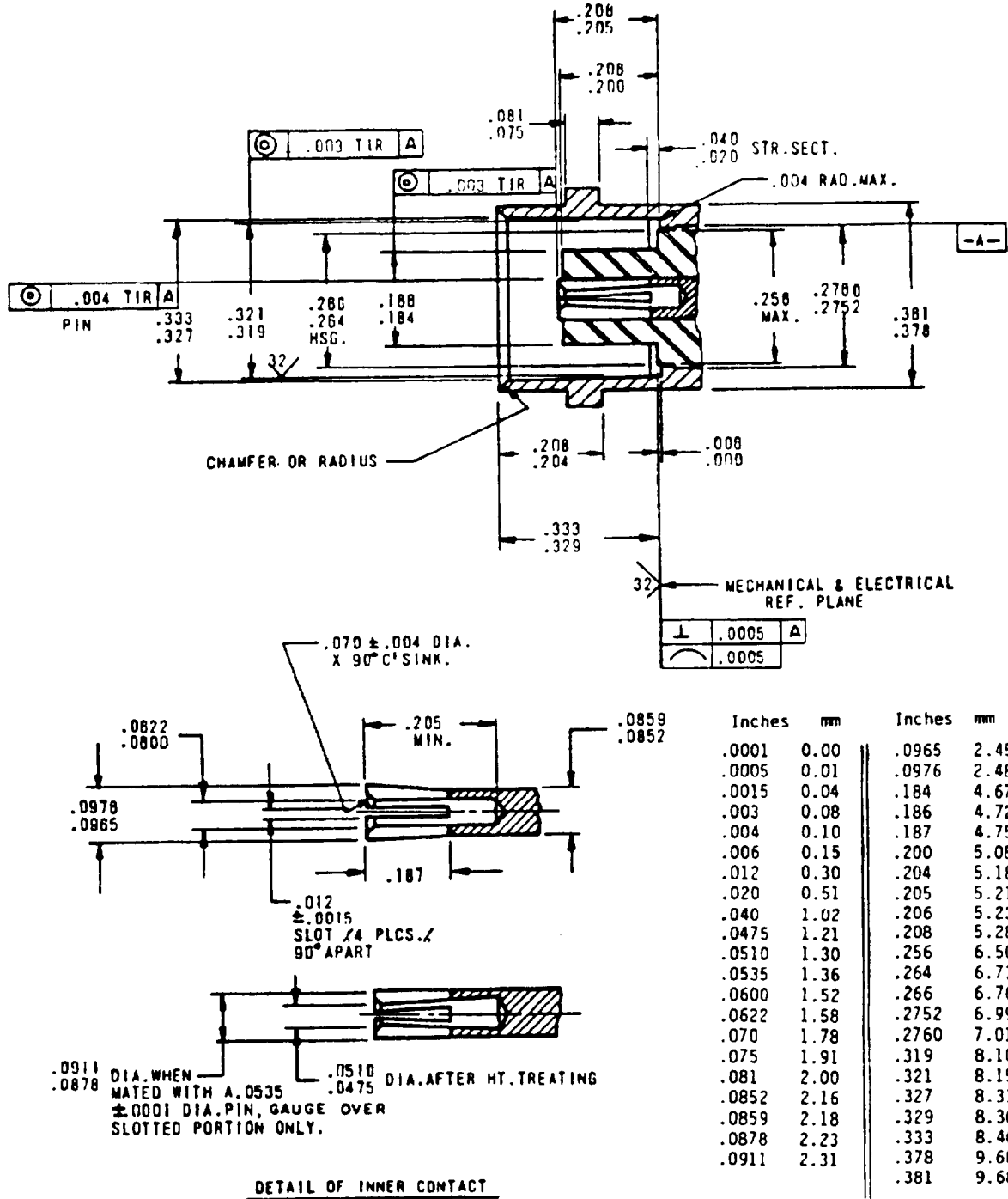

FIGURE 404-2. Interface, test connector, series BNC, socket contact.

MIL-STD-348A

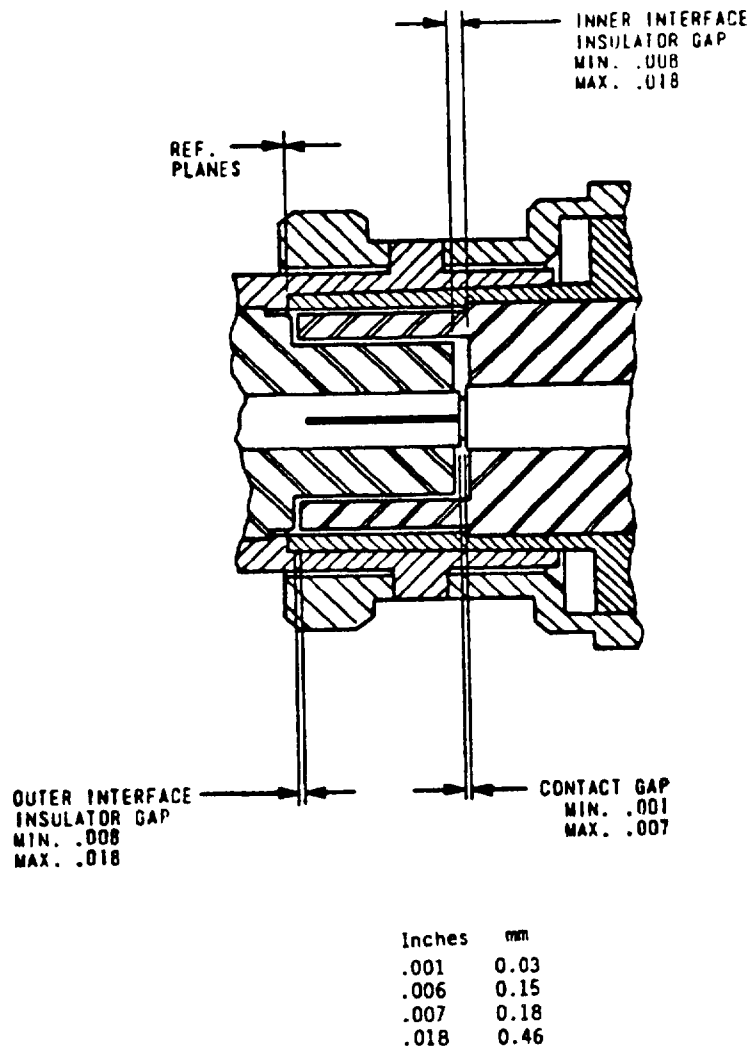

FIGURE 404-3. Interface, mated test connector, series BNC.

MIL-STD-348A

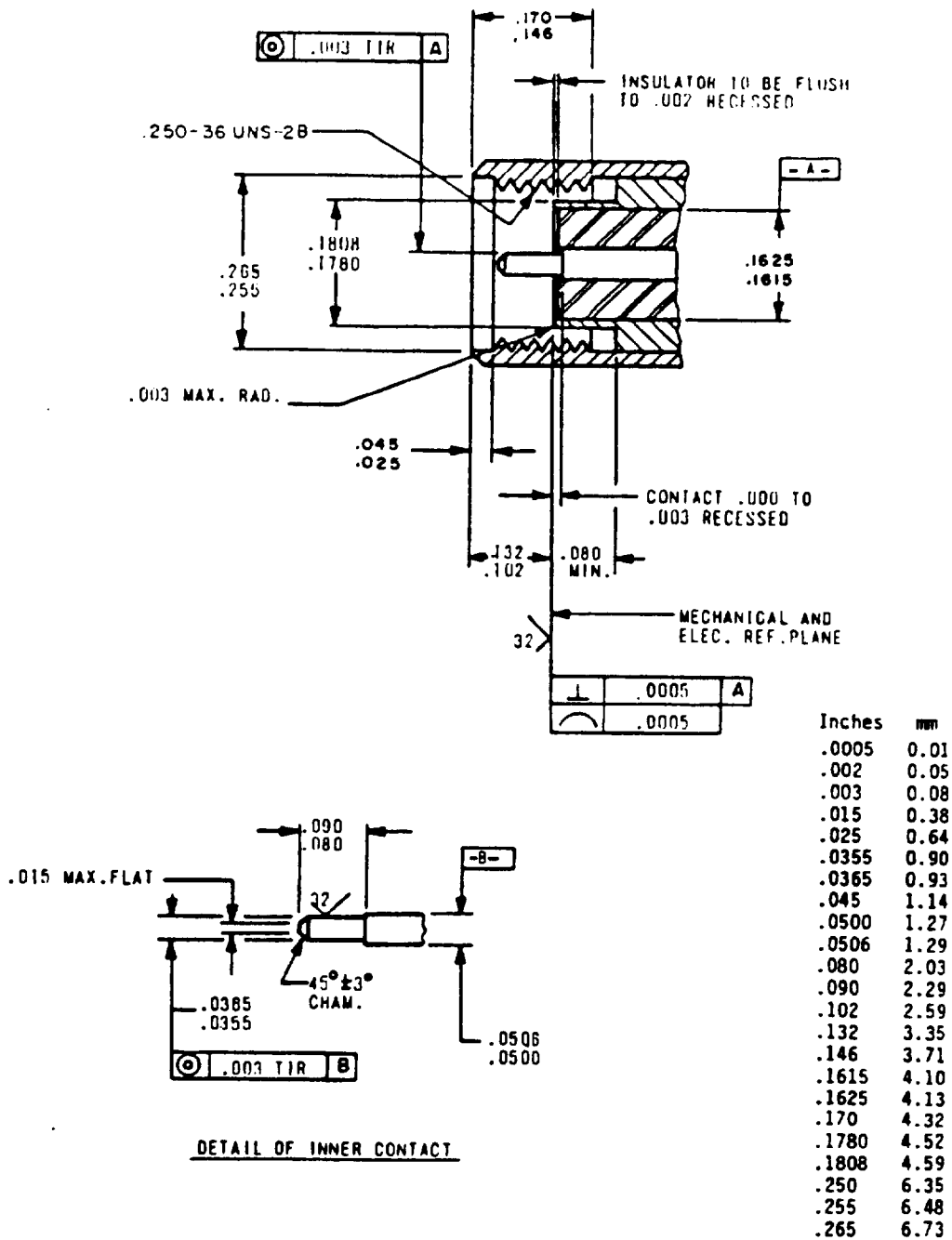

FIGURE 405-1. Interface, series SMA, pin contact.



MIL-STD-348A

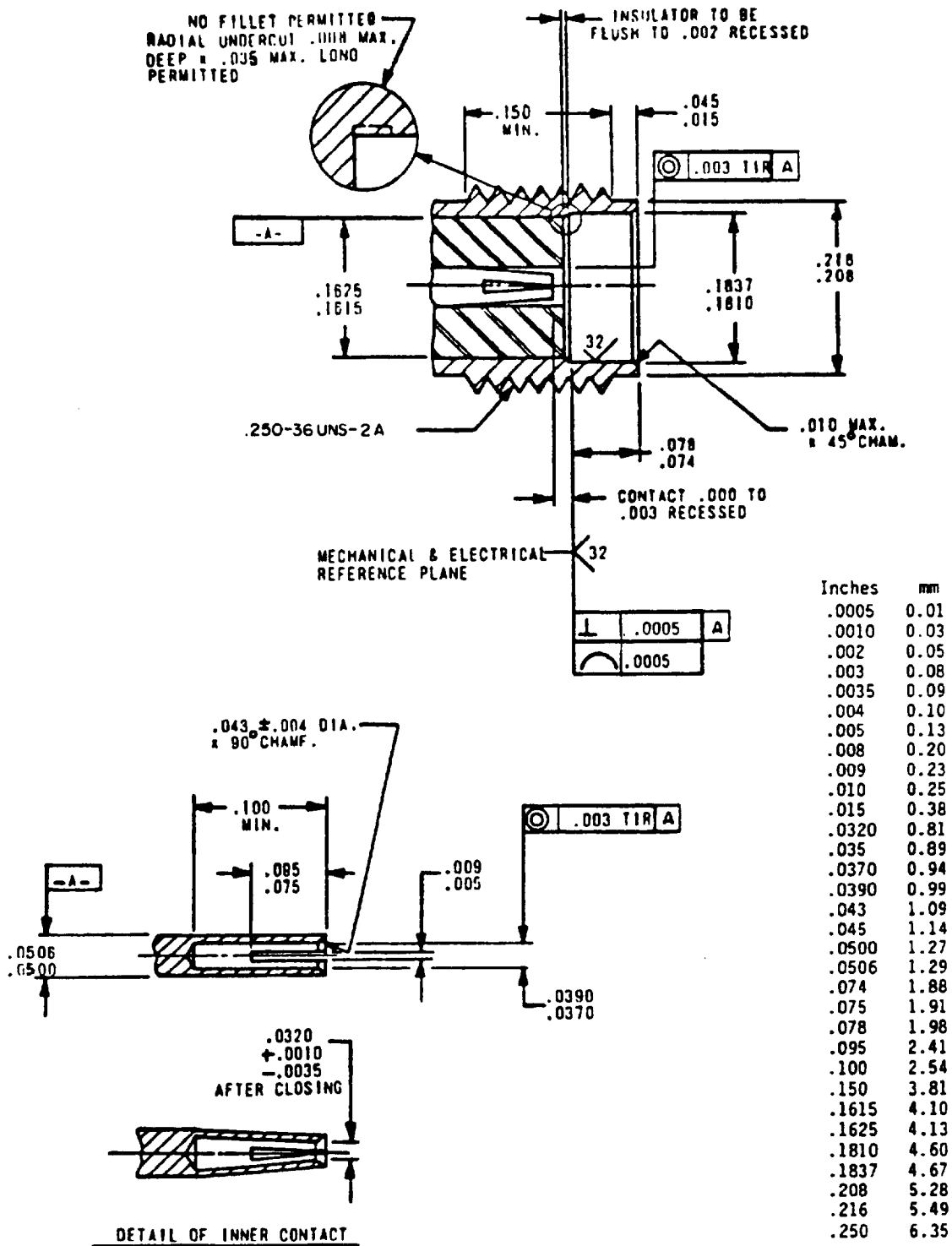
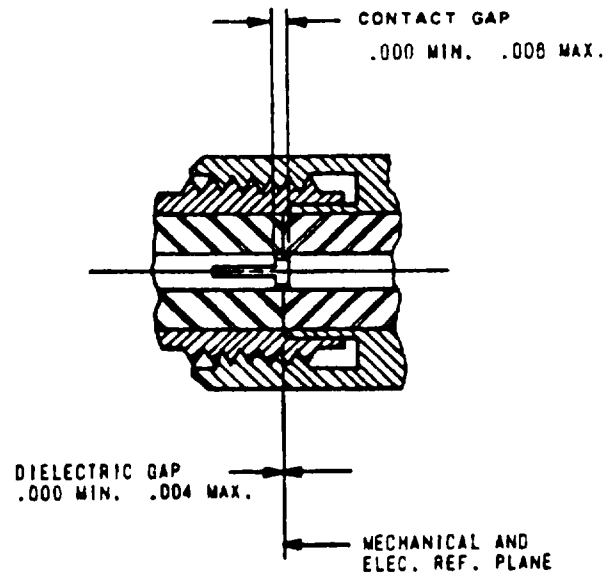

FIGURE 405-2. Interface, test connector, series SMA, socket contact.

MIL-STD-348A



Inches	mm
.004	0.10
.006	0.15

FIGURE 405-3. Interface, mated test connector, series SMA.

MIL-STD-348A

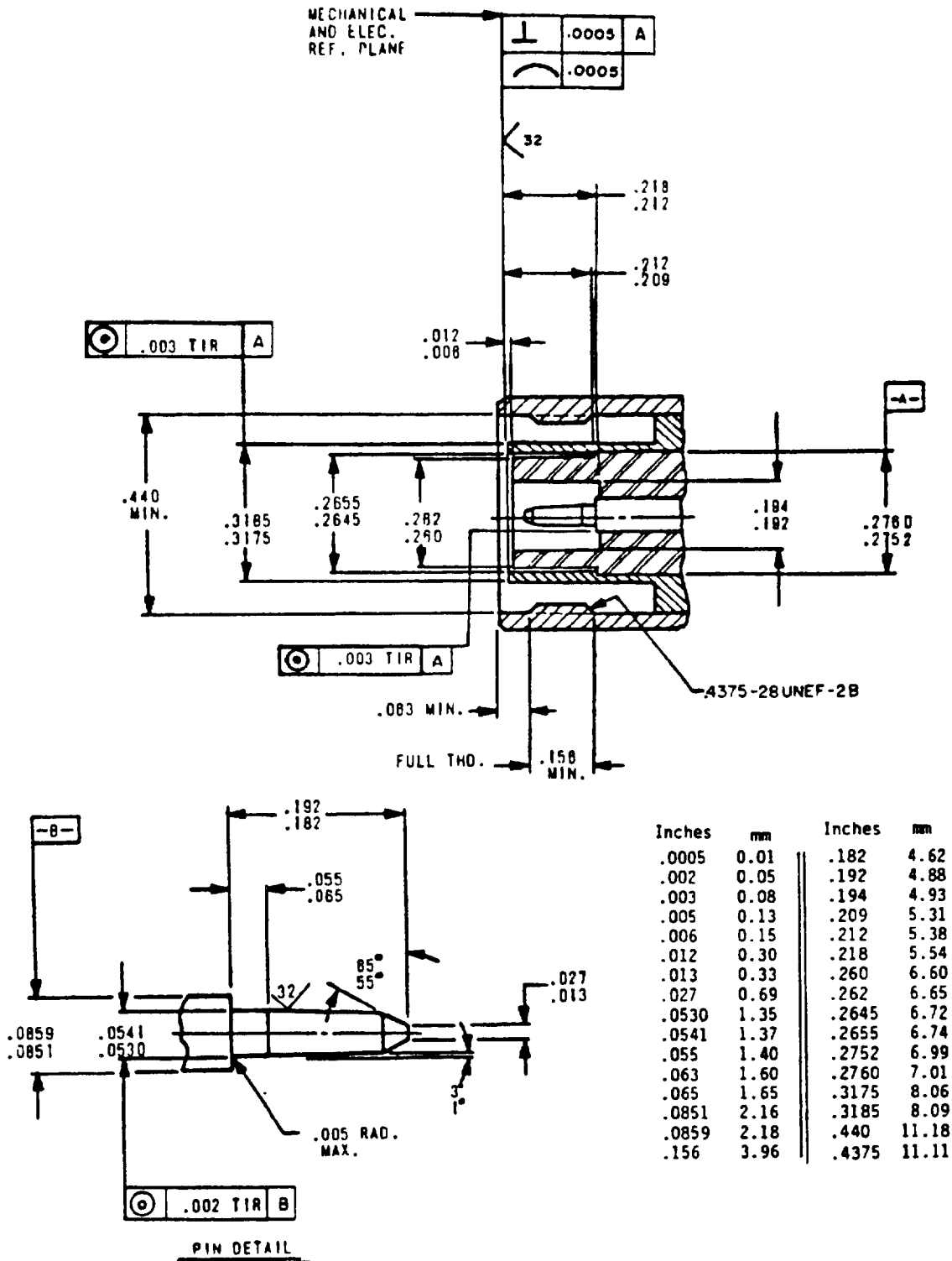

FIGURE 406-1. Interface, test connector, series TNC, pin contact.

MIL-STD-348A

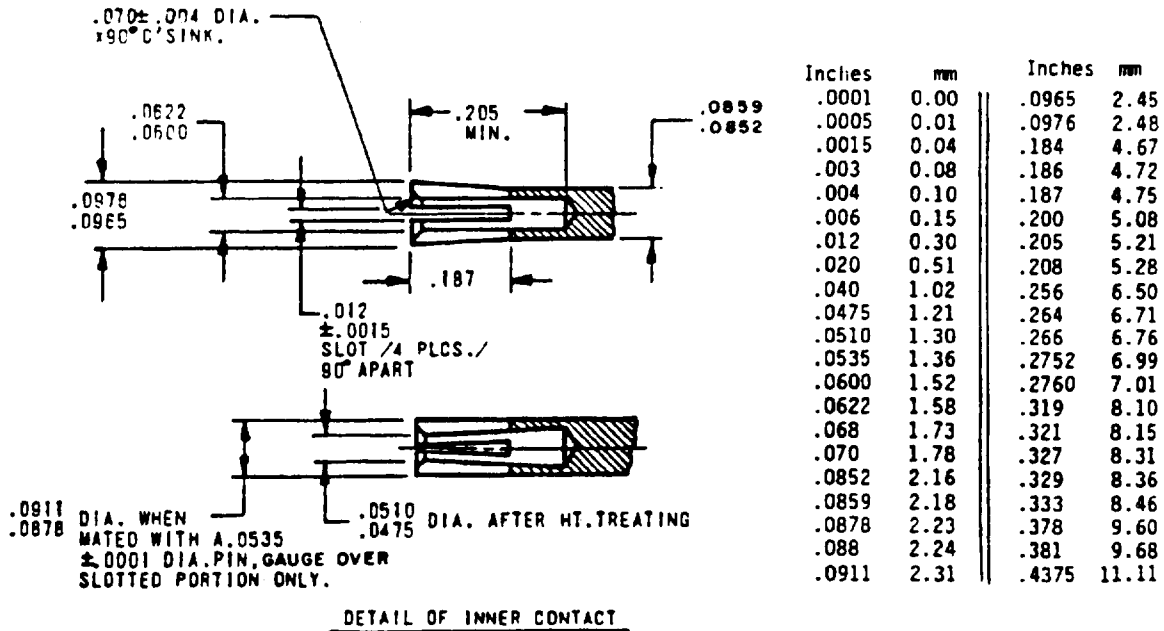
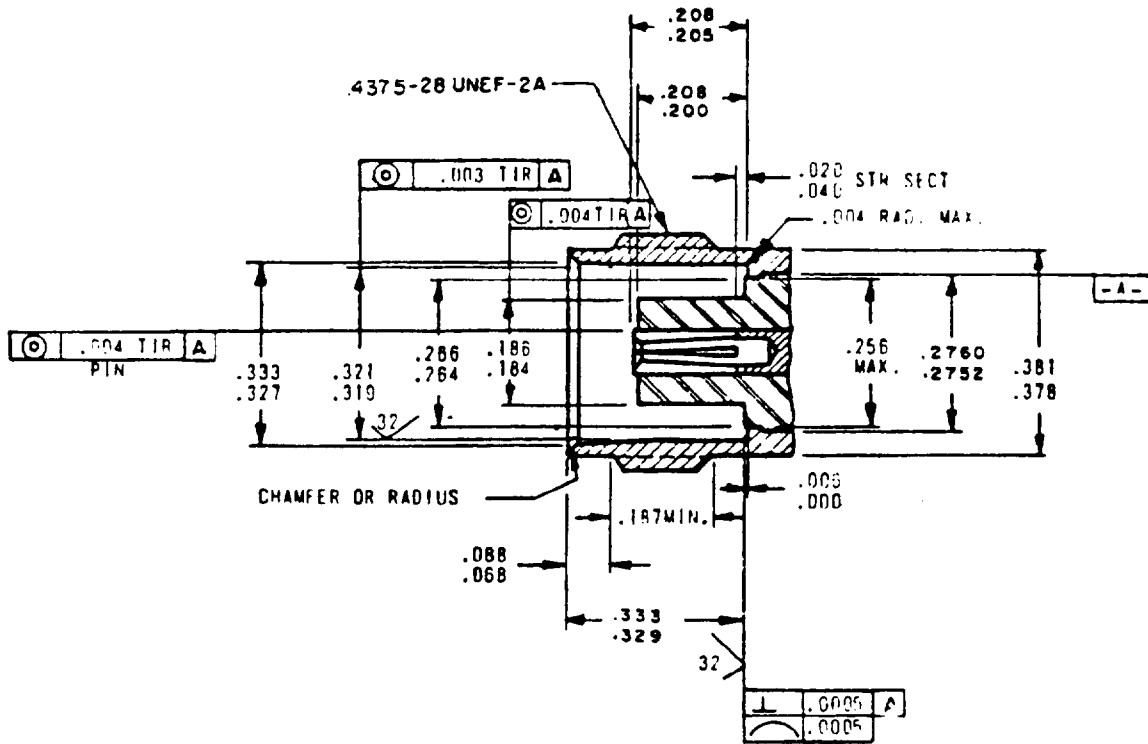
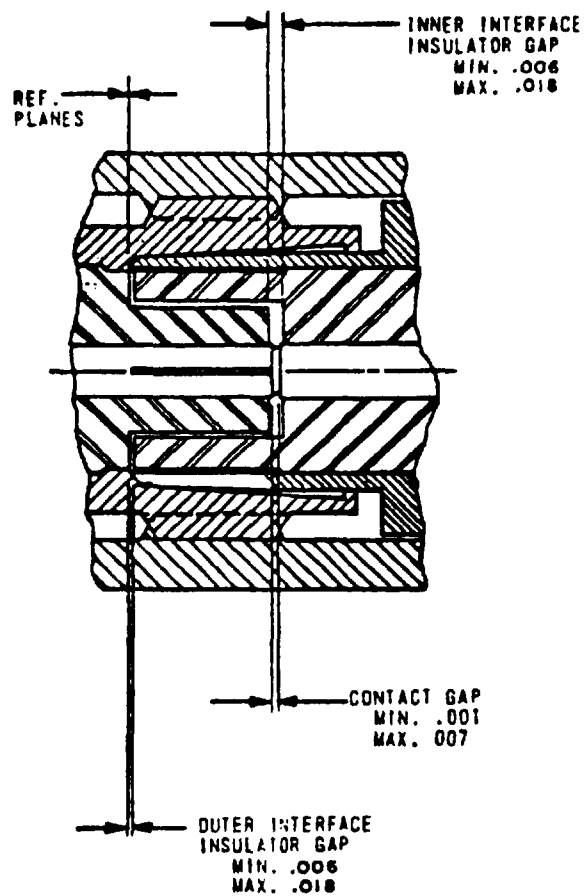

FIGURE 406-2. Interface, test connector, series TNC, socket contact.

MIL-STD-348A



Inches	mm
.001	0.03
.006	0.15
.007	0.18
.018	0.46

FIGURE 406-3. Interface, mated test connector, series TNC.

MIL-STD-348A

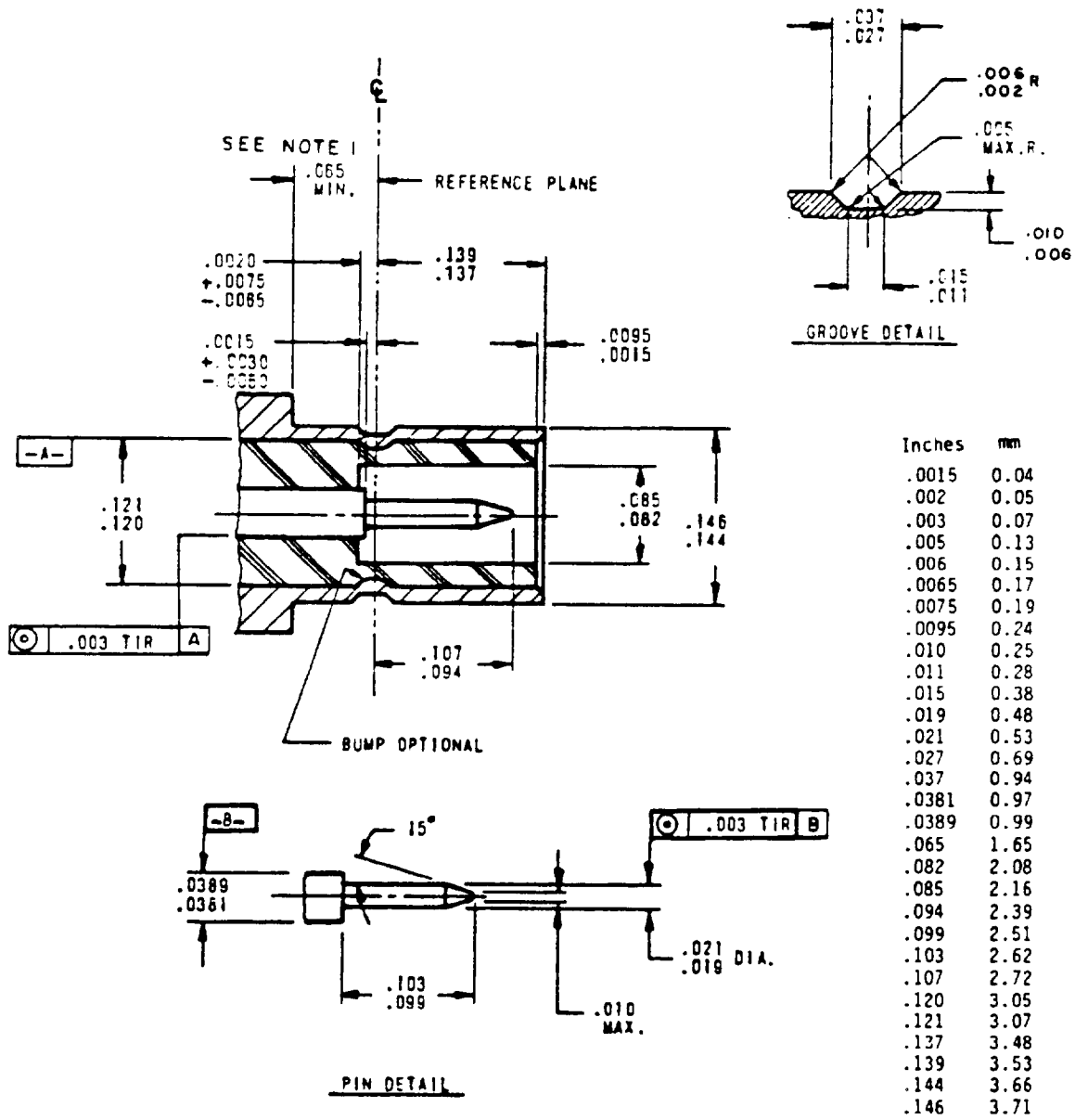

NOTE: Clearance for mating connector coupling nut.

FIGURE 407-1. Interface, test connector, series SMB, pin contact.

MIL-STD-348A

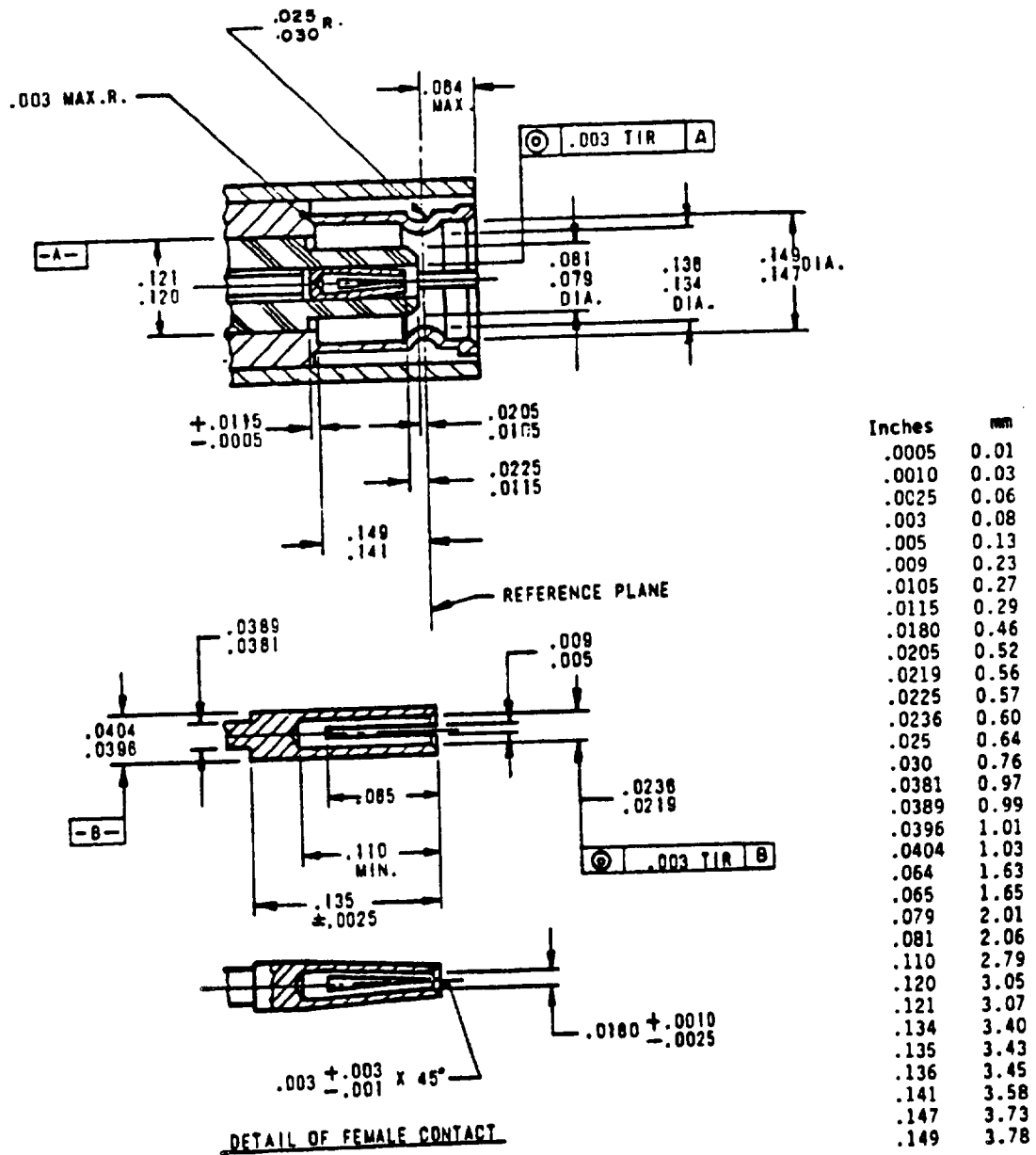
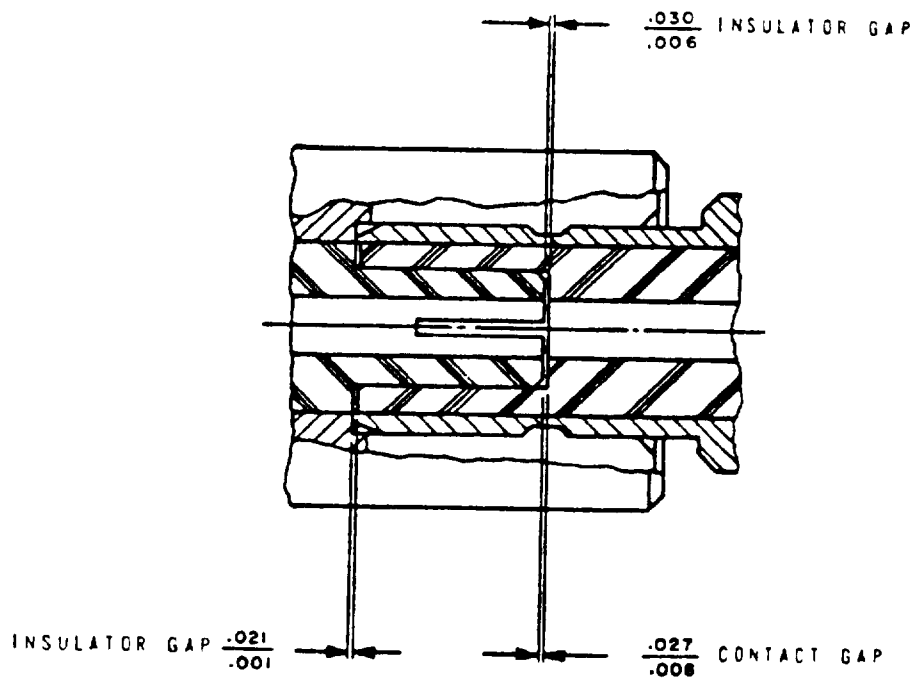

FIGURE 407-2. Interface, test connector, series SMB, socket contact.

MIL-STD-348A



Inches	MM
.001	0.03
.006	0.15
.008	0.20
.021	0.53
.027	0.69
.030	0.76

FIGURE 407-3. Interface, mated test connector, series SMB.



MIL-STD-348A

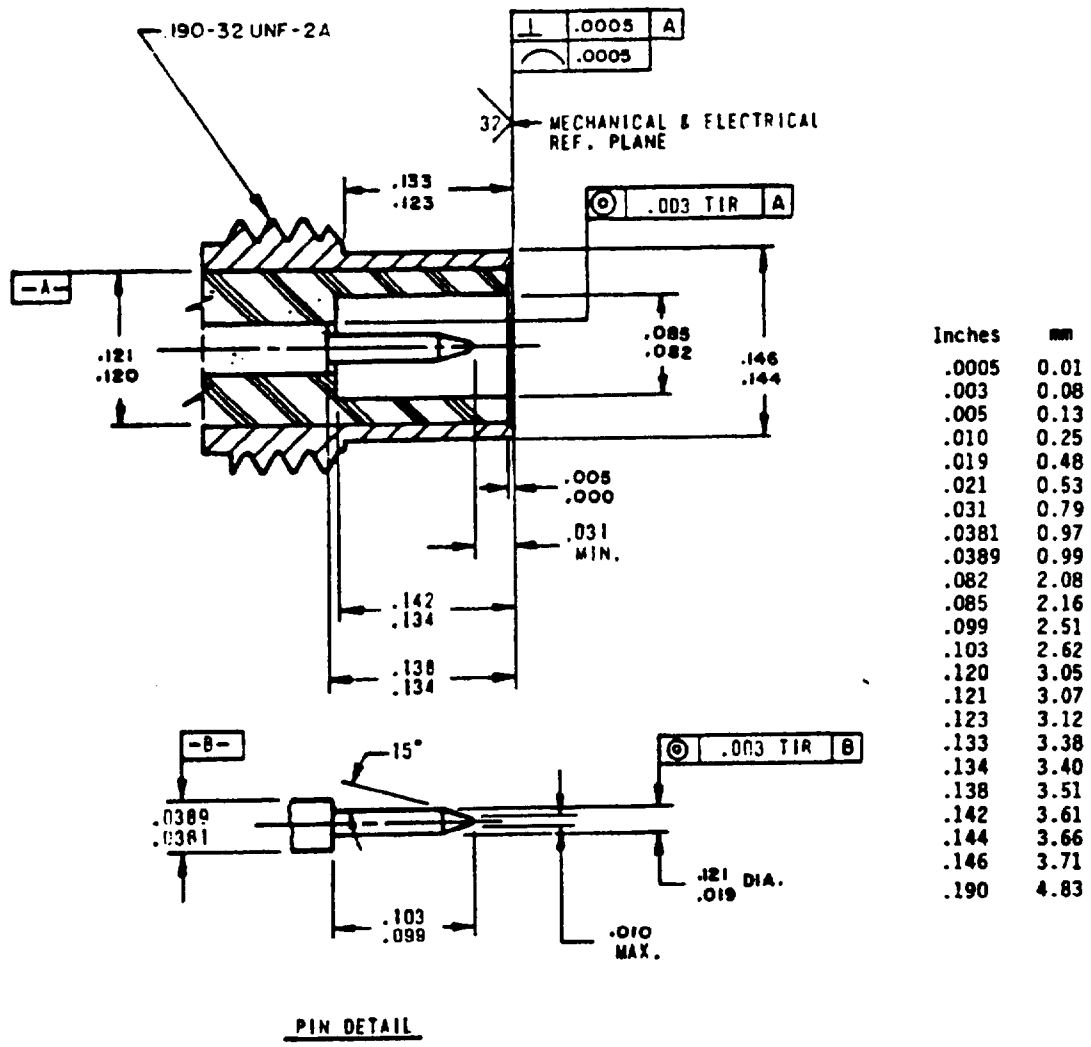

FIGURE 408-1. Interface, test connector, series SMC, pin contact.

MIL-STD-348A

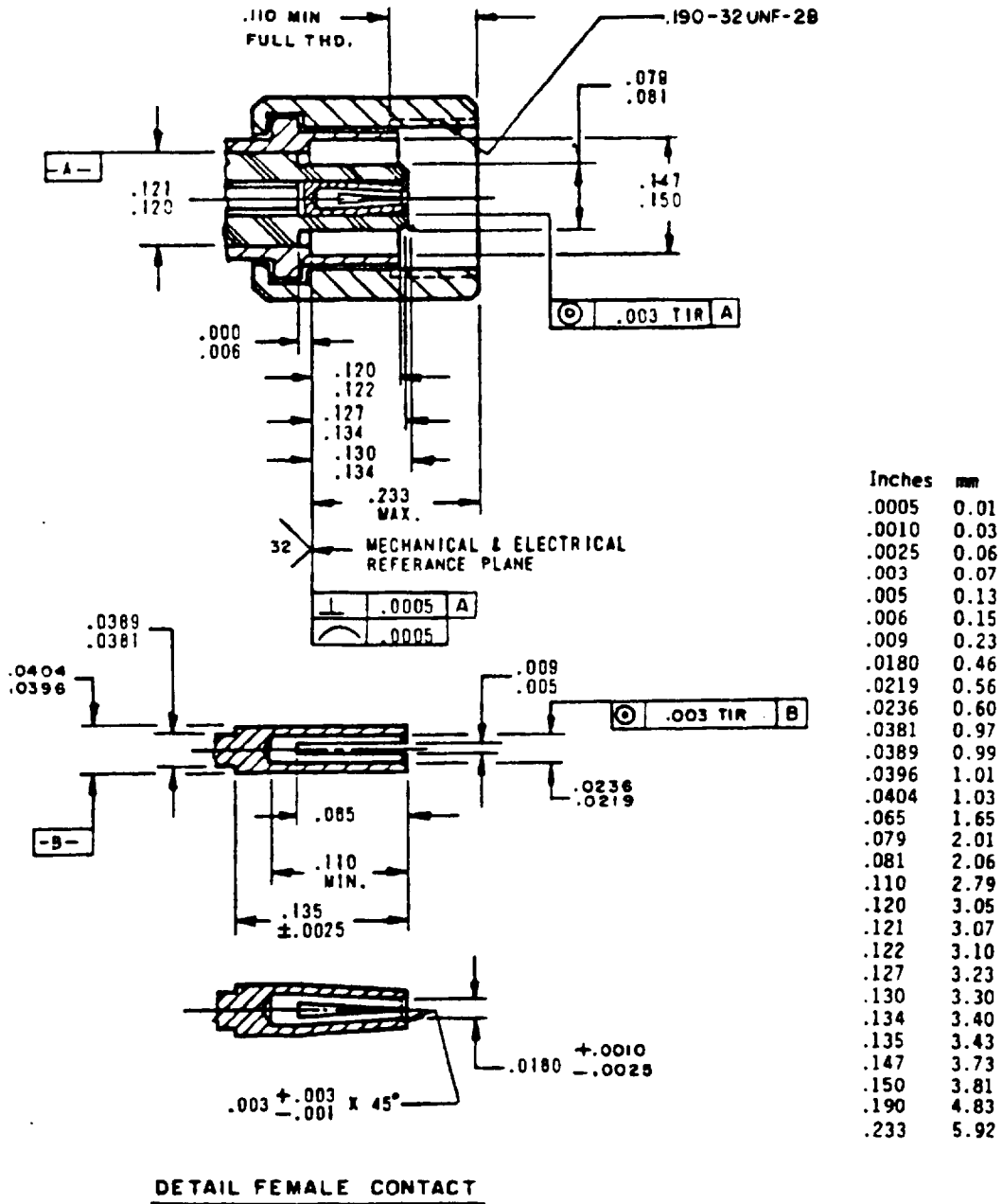
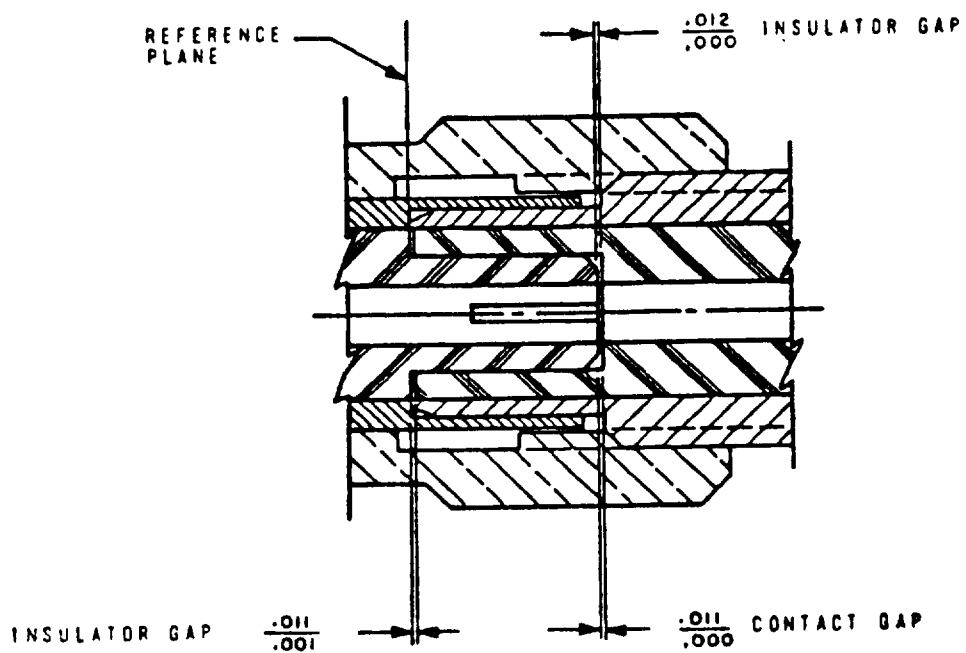

FIGURE 408-2. Interface, test connector, series SMC, socket contact.

MIL-STD-348A



Inches	mm
.001	0.03
.011	0.28
.012	0.30

FIGURE 408-3. Interface, mated test connector, series SMC.

MIL-STD-348A

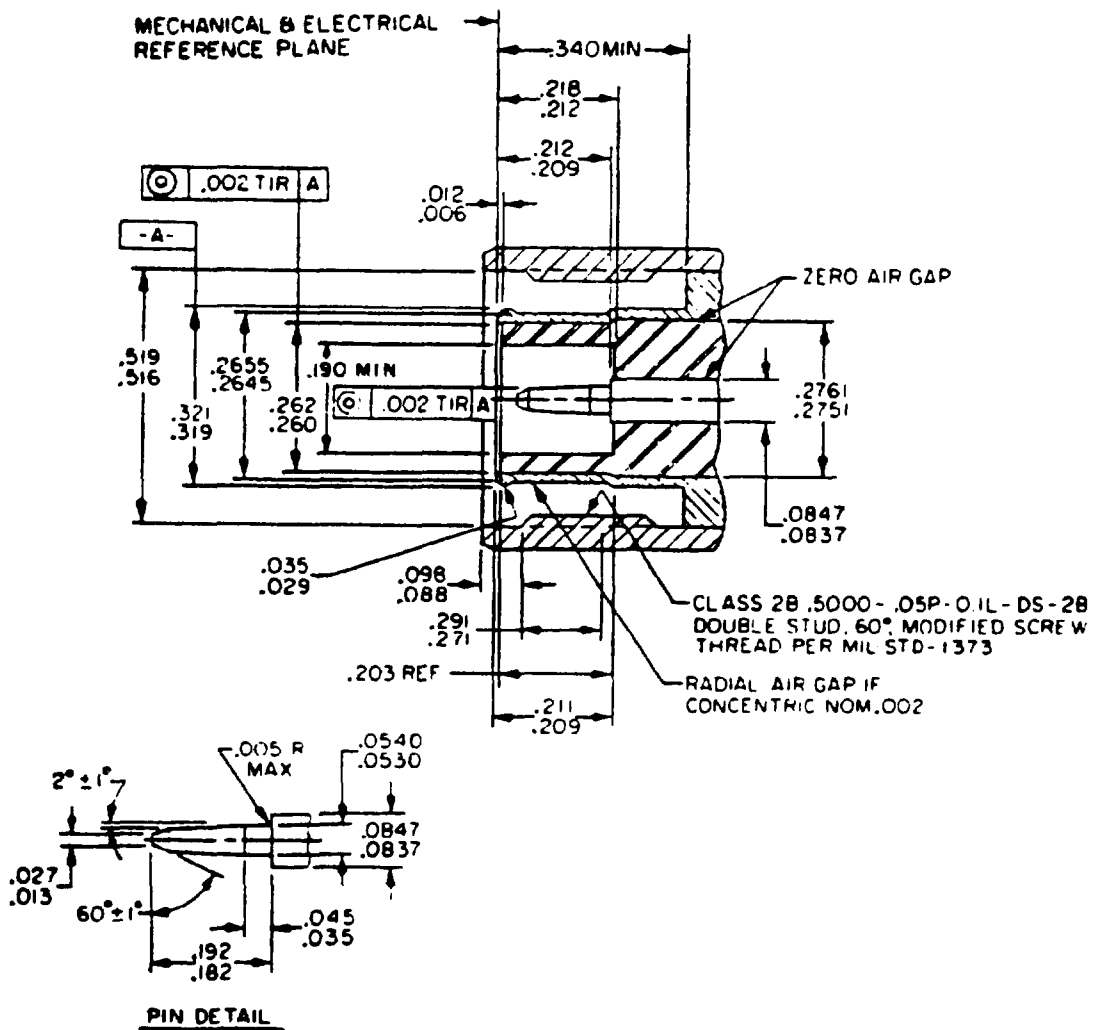

Inches	mm	Inches	mm	Inches	mm	Inches	mm
.002	0.05	.0530	1.346	.209	5.31	.2751	6.987
.005	0.13	.0540	1.371	.211	5.36	.2761	7.012
.006	0.15	.0837	2.125	.212	5.38	.291	7.39
.012	0.30	.0847	2.151	.218	5.54	.319	8.10
.013	0.33	.088	2.24	.260	6.60	.321	8.15
.027	0.69	.098	2.49	.262	6.65	.340	8.64
.029	0.74	.182	4.62	.2645	6.718	.5000	12.700
.035	0.89	.192	4.88	.2655	6.743	.516	13.11
.045	1.14	.203	5.16	.271	6.88	.519	13.18

FIGURE 409-1. Interface test connector, series QNC, pin contact.

MIL-STD-348A

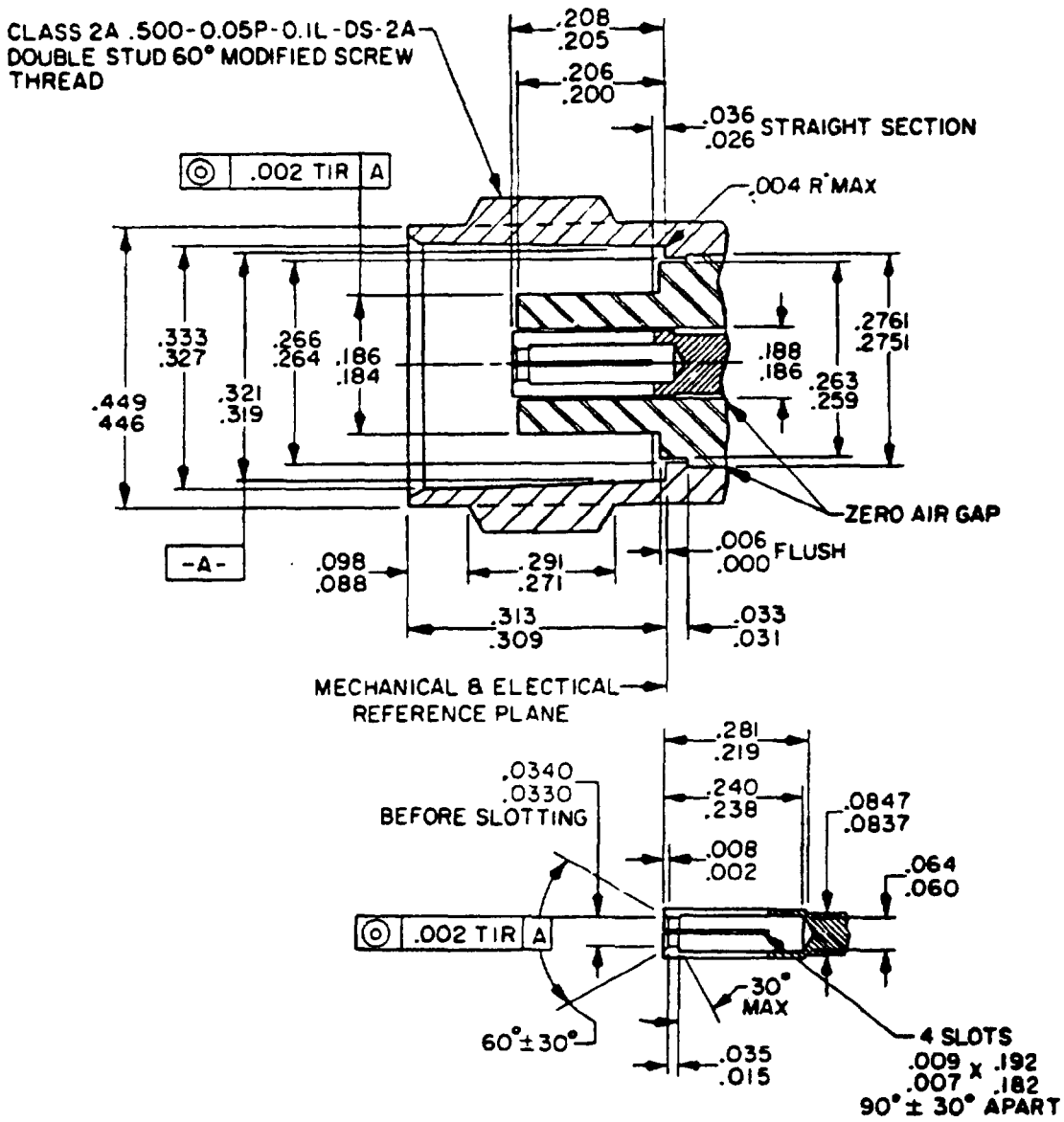

Inches	mm	Inches	mm	Inches	mm	Inches	mm	Inches	mm
.002	0.05	.034	0.86	.184	4.67	.240	6.10	.313	7.95
.004	0.10	.035	0.89	.186	4.72	.259	6.58	.319	8.10
.006	0.15	.036	0.91	.188	4.78	.263	6.68	.321	8.15
.007	0.18	.060	1.52	.192	4.88	.264	6.71	.327	8.31
.008	0.20	.064	1.63	.200	5.08	.271	6.88	.333	8.46
.009	0.23	.0837	2.13	.205	5.21	.2751	6.987	.446	11.33
.015	0.38	.0847	2.15	.206	5.23	.2761	7.012	.449	11.40
.026	0.66	.088	2.24	.208	5.28	.281	7.14	.500	12.70
.031	0.79	.098	2.49	.219	5.56	.291	7.39		
.033	0.84	.182	4.62	.238	6.05	.309	7.85		

FIGURE 409-2. Interface test connector, series QNC, socket contact.

MIL-STD-348A

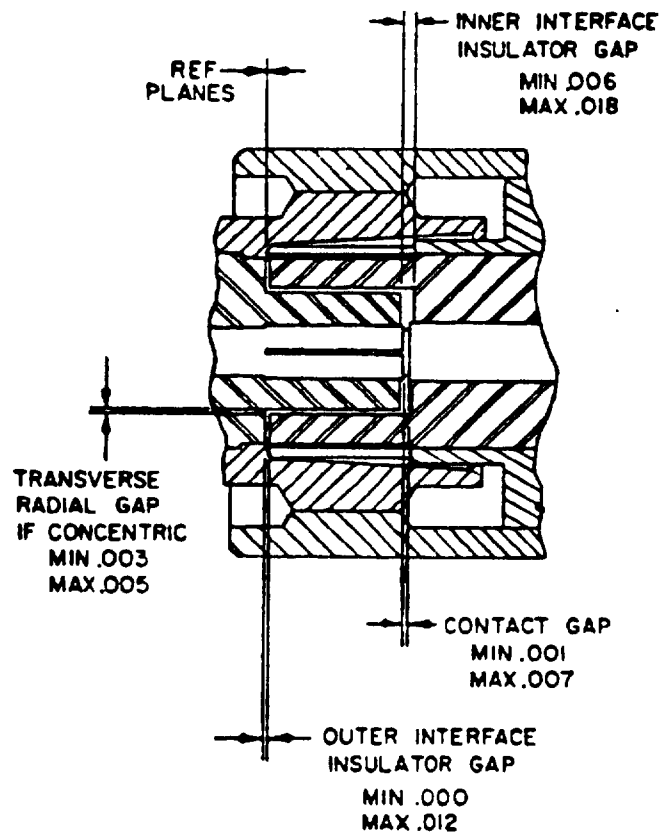

Inches	mm
.001	0.03
.003	0.08
.005	0.13
.006	0.15
.007	0.18
.012	0.30
.018	0.46

FIGURE 409-3. Gap of mated standard test connector, series QNC.

MIL-STD-348A

CLASS 2B, .6250-0.05P-Q.IL-DS-2B  
 DOUBLE STUB, 60°, MODIFIED SCREW  
 THREAD PER MIL-STD-1373

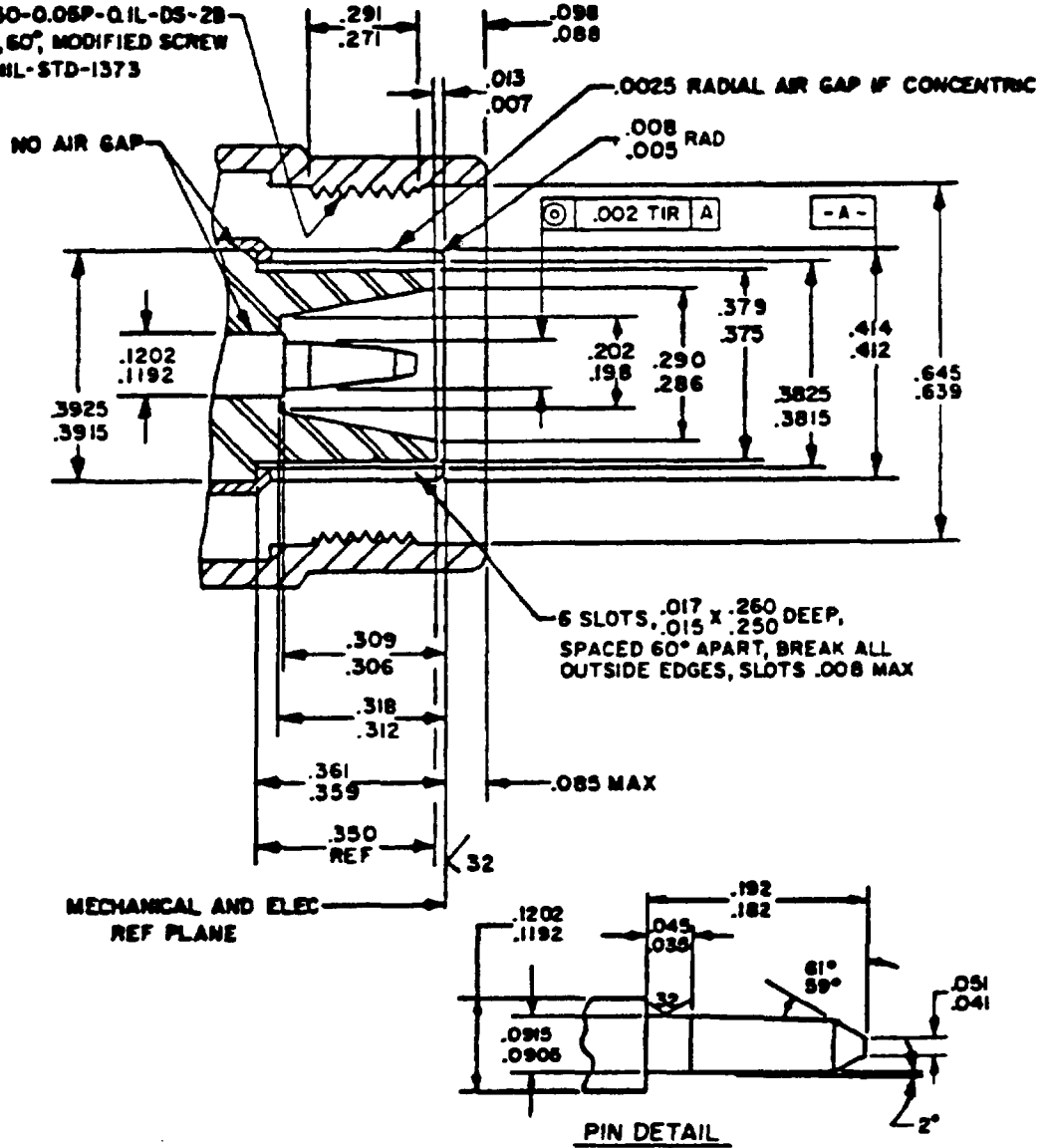
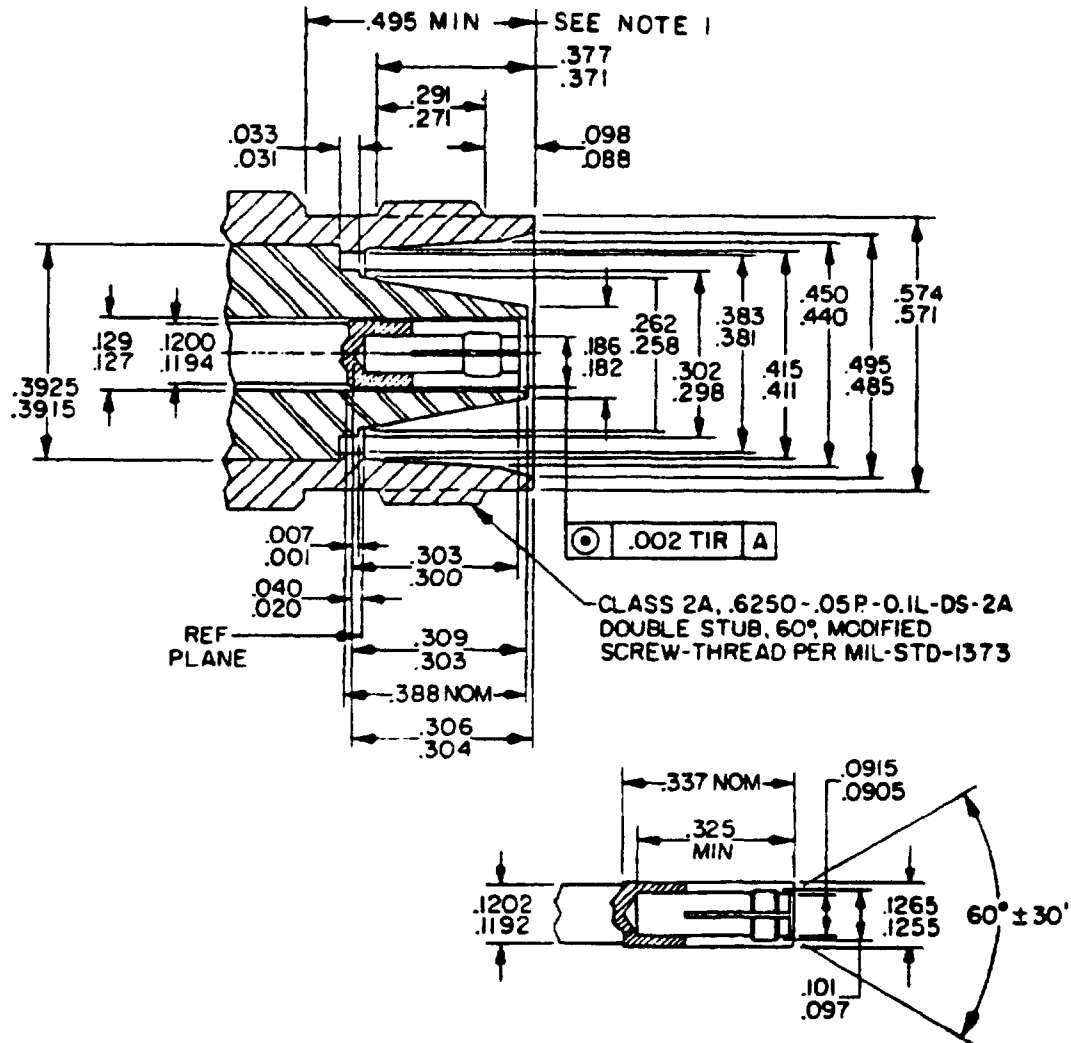

FIGURE 410-1. Interface test connector, series QSC, pin contact.

MIL-STD-348A



**SERIES QSC**

Inches	mm	Inches	mm	Inches	mm	Inches	mm	Inches	mm
.001	0.03	.098	2.49	.186	4.72	.309	7.85	.415	10.54
.002	0.05	.101	2.57	.258	6.55	.325	8.26	.440	11.18
.007	0.18	.1192	3.027	.262	6.65	.337	8.56	.450	11.43
.020	0.51	.1194	3.032	.271	6.88	.371	9.42	.485	12.32
.031	0.79	.1200	3.048	.291	7.39	.377	9.58	.495	12.57
.033	0.84	.1202	3.053	.298	7.57	.381	9.68	.571	14.50
.040	1.02	.1255	3.187	.300	7.62	.383	9.73	.574	14.58
.088	2.24	.1265	3.213	.302	7.67	.388	9.86	.6250	15.875
.0905	2.298	.127	3.23	.303	7.70	.3915	9.944		
.0915	2.324	.129	3.28	.304	7.72	.3925	9.969		
.097	2.46	.182	4.62	.306	7.77	.411	10.44		

NOTE: Clearance for mating connector coupling nut.

FIGURE 410-2. Interface test connector, series QSC, socket contact.

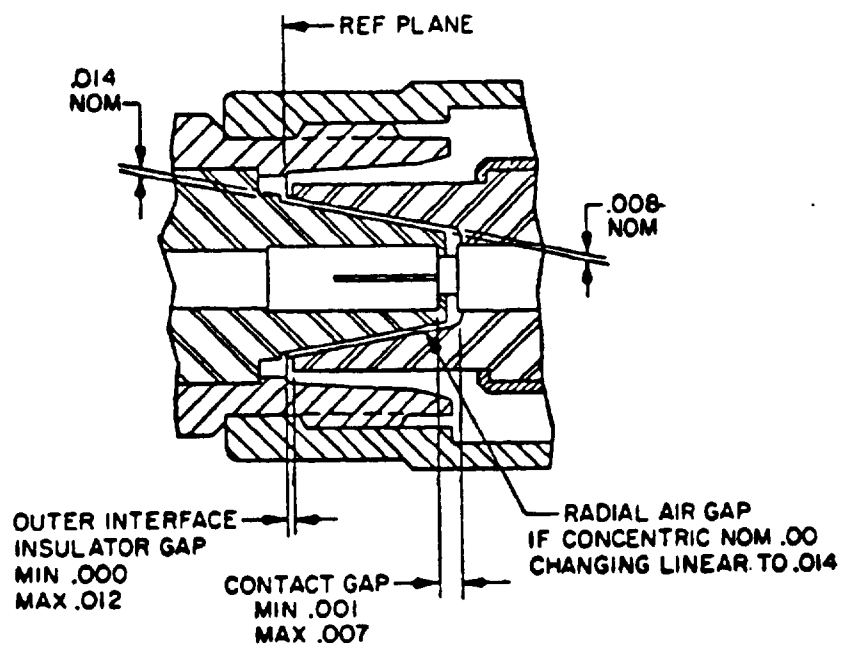

MIL-STD-348A

**SERIES QSC**

Inches	mm
.001	0.03
.007	0.18
.008	0.20
.012	0.30
.014	0.36

FIGURE 410-3. Gap of mated standard test connector, series QSC.