

INCH-POUND

MIL-STD-202-203

w/CHANGE 1

28 April 2020

---

SUPERSEDING

MIL-STD-202-203

18 April 2015

**DEPARTMENT OF DEFENSE  
TEST METHOD STANDARD  
METHOD 203, RANDOM DROP**



AMSC N/A

FSC 59GP



MIL-STD-202-203  
w/CHANGE 1

FOREWORD

1. This standard is approved for use by all Departments and Agencies of the Department of Defense.
2. This entire standard has been revised. This revision has resulted in many changes to the format, but the most significant one is the splitting the document into test methods. See MIL-STD-202 for the change summary.
3. Comments, suggestions, or questions on this document should be emailed to [std202@dla.mil](mailto:std202@dla.mil) or addressed to: Commander, Defense Logistics Agency, DLA Land and Maritime, ATTN: VAT, P.O. Box 3990, Columbus, OH 43218-3990. Since contact information can change, you may want to verify the currency of this address information using the ASSIST Online database at <https://assist.dla.mil>.

MIL-STD-202-203  
w/CHANGE 1

SUMMARY OF CHANGE 1 MODIFICATIONS

1. Modified Figure 4, Note 3, to current version of ASTM-A519/A519M.

MIL-STD-202-203  
w/CHANGE 1

## CONTENTS

<u>PARAGRAPH</u>		<u>PAGE</u>
	<u>FOREWORD</u> .....	ii
1.	<u>SCOPE</u>	1
1.1	<u>Purpose</u> .....	1
2.	<u>APPLICABLE DOCUMENTS</u>	1
3.	<u>DEFINITIONS</u>	1
4.	<u>GENERAL REQUIREMENTS</u>	1
4.1	<u>Apparatus</u> .....	1
4.2.	<u>Procedure</u> .....	1
5.	<u>DETAILED REQUIREMENTS</u>	2
5.1	<u>Measurements</u> .....	2
6.	<u>NOTES</u>	7
6.1	<u>Supersession data</u> .....	7
<u>FIGURE</u>		<u>PAGE</u>
1.	<u>Typical assembly of four-cage random-drop-test machine</u> .....	2
2.	<u>Cage assembly</u> .....	3
3.	<u>Cage (interior)</u> .....	4
4.	<u>Sleeve</u> .....	6

MIL-STD-202-203  
w/CHANGE 1

METHOD 203  
RANDOM DROP

1. SCOPE

1.1 Purpose. The random-drop test is used to determine the effects on component parts of random, repeated impact due to handling, shipping, and other field service conditions. The test is an accelerated test designed to indicate structural and mechanical weaknesses of types not necessarily detected in shock and vibration tests.

2. APPLICABLE DOCUMENTS

2.1 General. The documents listed in this section are specified in sections 4 and 5. While every effort has been made to ensure the completeness of this list, document users are cautioned that they must meet all specified requirements documents cited in sections 4 and 5, and the individual test methods of this standard, whether or not they are listed.

2.2.1 Specifications, standards, and handbooks. The following specifications, standards, and handbooks form a part of this document to the extent specified herein. Unless otherwise specified, the issues of these documents are those cited in the solicitation or contract.

FEDERAL SPECIFICATIONS

[QQ-B-654](#) - Brazing Alloys, Silver  
[QQ-S-698](#) - Steel, Sheet and Strip, Low Carbon

(Copies of these documents are available online at <https://quicksearch.dla.mil>)

2.3 Non-Government publications. The following documents form a part of this document to the extent specified herein. Unless otherwise specified, the issues of these documents are those cited in the solicitation or contract.

ASTM INTERNATIONAL (ASTM)

[ASTM A519/A519M](#) - Standard Specification For Seamless Carbon and Alloy Steel Mechanical Tubing

(Copies of this document are available online at [www.astm.org](http://www.astm.org))

3. DEFINITIONS

This section not applicable to this standard.

4. GENERAL REQUIREMENTS

4.1 Apparatus. The random-drop test machine consists of an assembly of either two or four steel cages as shown on figure 2, with provisions for rotation about a common axis. The interior of each cage shall be as shown on figure 3. A typical 4-cage machine is shown on figure 1. Steel sleeves as shown on figure 4 shall be used to mount the specimen.

4.2 Procedure. The specimen shall be rigidly mounted by the normal mounting means in the steel sleeve so that no part of the specimen, including terminals or external hardware of the component, will extend beyond the sleeve. When necessary, a suitable adapter may be used within the sleeve. End caps shall not be used on the sleeves. Through bolts may be employed as needed to mount the specimens in the sleeve. Only one sleeve shall be placed in each cage during test. The number of specimens mounted in each sleeve shall be limited only by the available space. Specimens shall be subjected to the random-drop test for a period of 45 minutes at a speed of four to six (4 – 6) revolutions per minute. The machine shall be rotated in the direction shown on figure 3.

MIL-STD-202-203  
w/CHANGE 1

5. DETAILED REQUIREMENTS

5.1 MEASUREMENTS. Upon completion of the test, measurements shall be made as specified in the individual specification.

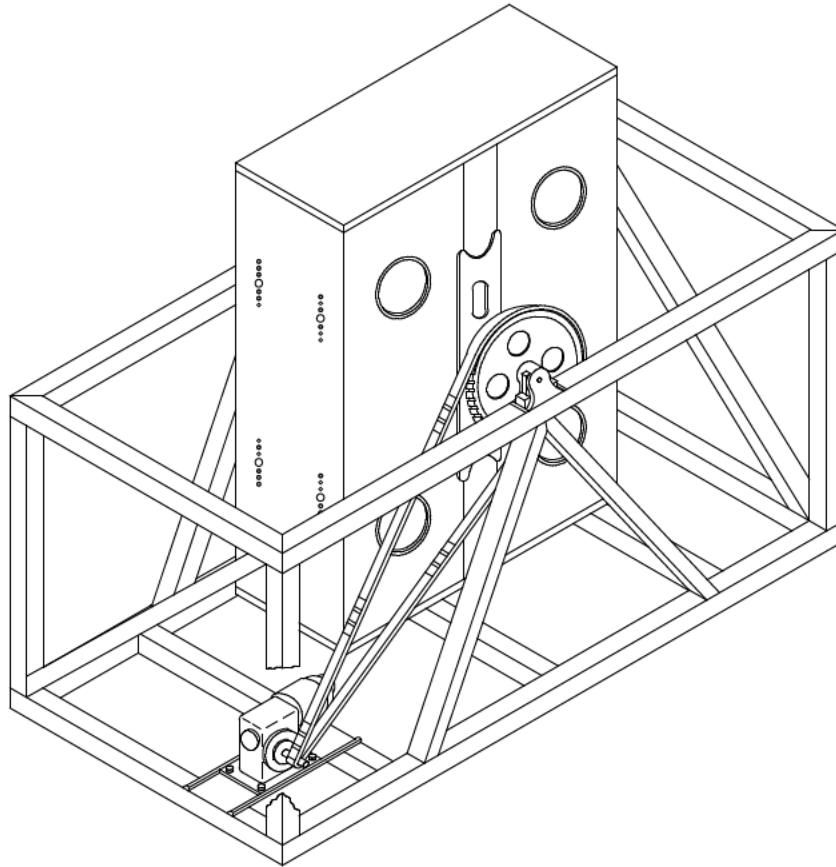

FIGURE 1. Typical assembly of four-cage random-drop-test machine.

MIL-STD-202-203  
w/CHANGE 1

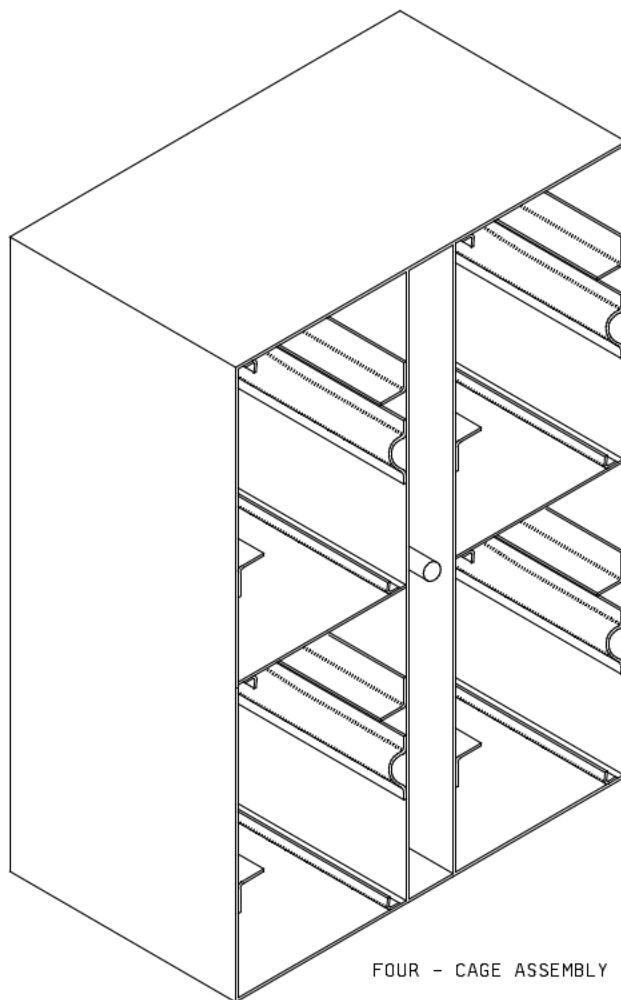

FIGURE 2. Cage assembly.

MIL-STD-202-203  
w/CHANGE 1

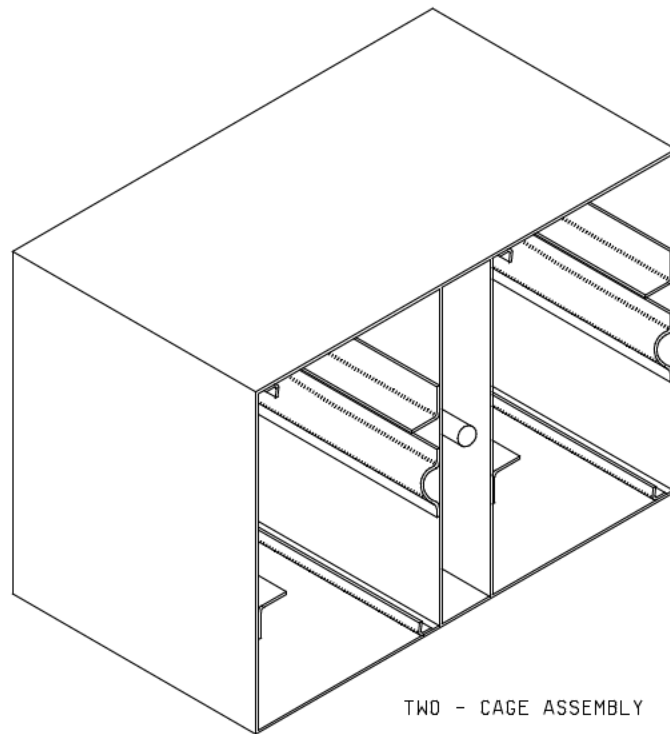
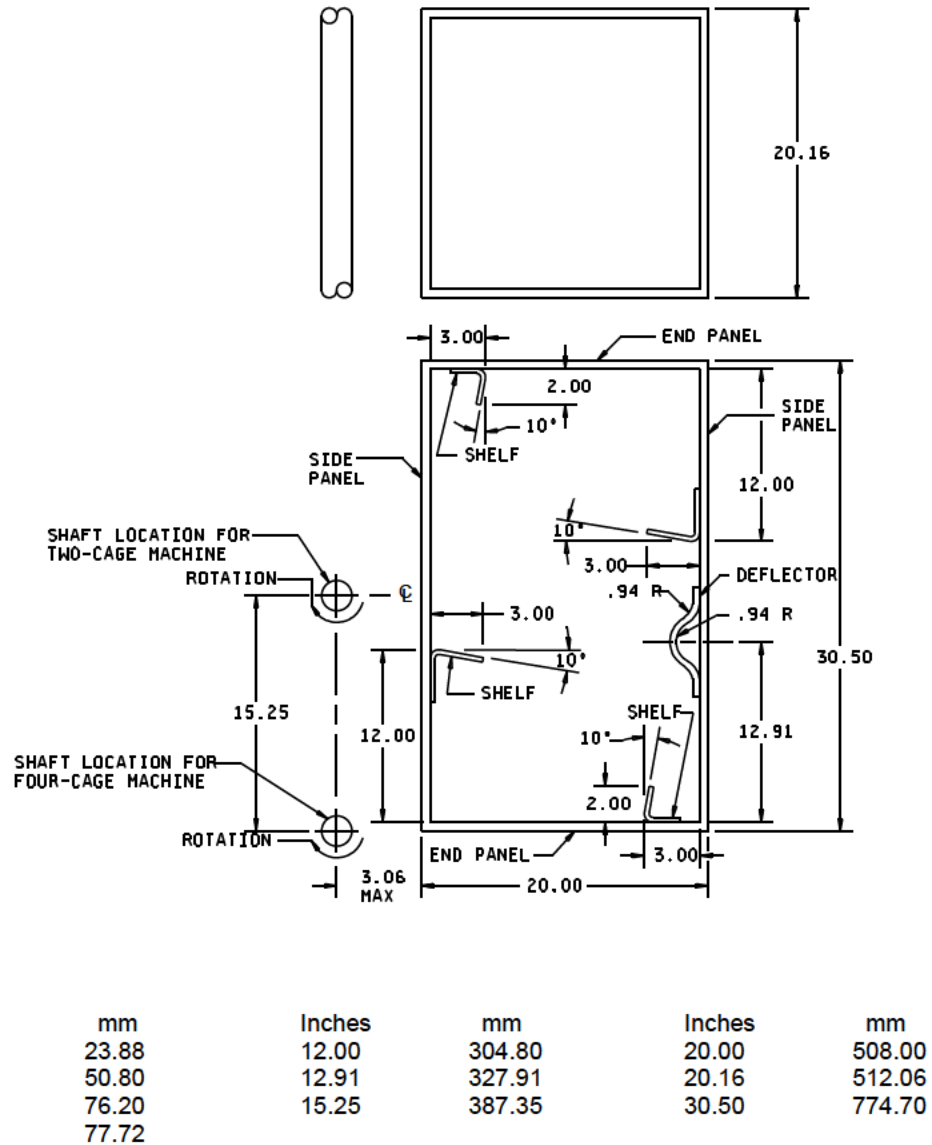

FIGURE 2. Cage assembly - Continued.



MIL-STD-202-203  
w/CHANGE 1



NOTES:

1. Unless otherwise specified, tolerances are  $\pm 0.06$  (1.52 mm) on decimals and  $\pm 0^\circ 30'$  on angles.
2. Material for end and side panels shall be steel .0747 (1.90 mm) nominal thickness.
3. Material for shelves and deflectors shall be steel .083 (2.11 mm) nominal thickness.

FIGURE 3. Cage (interior).

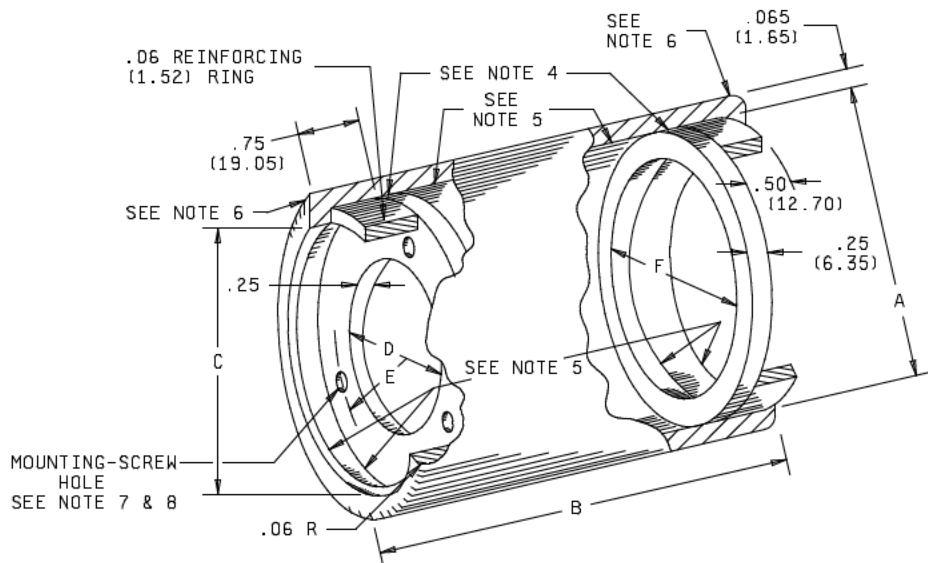
MIL-STD-202-203  
w/CHANGE 1

Dimensions					
A	B ±.06 (1.52)	C ±.06 (1.52)	D	E (Rad)	F ±.06 (1.52)
3.870 (98.30)	4.03 (102.36)	3.75 (95.25)	2.220 (56.39)	<u>7</u> / 1.220 (30.99)	3.370 (85.60)
3.870 (98.30)	4.03 (102.36)	3.75 (95.25)	2.820 (71.63)	<u>7</u> / 1.580 (40.13)	3.370 (85.60)
4.870 (123.70)	5.03 (127.76)	4.75 (120.65)	3.820 (97.03)	<u>8</u> / 2.062 (52.37)	4.370 (111.00)

## NOTES:

1. Dimensions are given in inches. Metric equivalents are in parentheses and are given for general information only.
2. Unless otherwise specified, tolerances are ±.005 inch (0.13 mm) for three place decimals, and ±.02 inch (0.51 mm) for two place decimals.
3. Material for sleeve and reinforcing rings shall be carbon steel, condition CWSR, grade MT1015 or 1015, conforming to [ASTM A519/A519M](#).
4. Material shall be hot-rolled steel strip, annealed condition, annealed finish, conforming to [QQ-S-698](#).
5. Silver solder all around. Silver solder shall conform to class 1 of [QQ-B-654](#).
6. End of cylinder to be spun-over after insertion of reinforcing ring.
7. Radius of 3 holes equally spaced.
8. Radius of 6 holes equally spaced.

FIGURE 4. Sleeve.

MIL-STD-202-203  
w/CHANGE 1

6. NOTES

(This section contains information of a general or explanatory nature that may be helpful, but is not mandatory.)

6.1 Supersession data. The main body and 38 parts of this revision of MIL-STD-202 replace superseded MIL-STD-202.

6.2 Change notations. The margins of this standard are marked with vertical lines to indicate modifications generated by this change. This was done as a convenience only and the Government assumes no liability whatsoever for any inaccuracies in these notations. Bidders and contractors are cautioned to evaluate the requirements of this document based on the entire content irrespective of the marginal notations.

Custodians:

Army - CR  
Navy - EC  
Air Force - 85  
DLA - CC

Preparing activity:  
DLA – CC

(Project 59GP-2020-003)

Review activities:

Army - AR, AT, AV, CR4, MI, SM, TE  
Navy - AS, OS, SH  
Air Force - 19  
NSA - NS

NOTE: The activities listed above were interested in this document as of the date of this document. Since organizations and responsibilities can change, you should verify the currency of the information above using the ASSIST Online database at <https://assist.dla.mil/>