

MIL-STD-188-161A
4 JULY 1988

SUPERSEDING
MIL-STD-188-161
30 JANUARY 1981

MILITARY STANDARD

INTEROPERABILITY AND PERFORMANCE

STANDARDS FOR

DIGITAL FACSIMILE EQUIPMENT



AREA SLHC/TCTS

NO DELIVERABLE DATA
REQUIRED BY THIS DOCUMENT

DISTRIBUTION STATEMENT A. Approved for
public release; distribution is unlimited.

MIL-STD-188-161A

DEPARTMENT OF DEFENSE
WASHINGTON, DC 20301

Interoperability and Performance Standards for
Digital Facsimile Equipment
MIL-STD-188-161A

1. This military standard is approved and mandatory for use by all Departments and Agencies of the Department of Defense in accordance with the Under Secretary of Defense for Research and Engineering memorandum dated 15 August 1983
2. Beneficial comments (recommendations, additions, deletions) and any pertinent data which may be of use in improving this document should be addressed to: Joint Tactical Command, Control, and Communications Agency, Washington Office, ATTN: Technical Standards Office, C3A-DWS, 11440 Isaac Newton Square, North, Reston, VA. 22090-5006, by using the self-addressed Standardization Document Improvement Proposal (DD Form 1426) appearing at the end of this document, or by letter.

MIL-STD-188-161A

FOREWORD

1. Originally, Military Standard 188 (MIL-STD-188) covered tactical and long haul communications system technical standards, but later evolved through divisions (MIL-STD-188A, MIL-STD-188B), into a document applicable to tactical communications only (MIL-STD-188C).
2. The Defense Communications Agency (DCA) published DCA Circulars promulgating standards and engineering criteria applicable to the long haul Defense Communications System (DCS) and to the technical support of the National Military Command System (NMCS).
3. As a result of a Joint Chiefs of Staff (JCS) action, standards for all military communications are now being published in a MIL-STD-188-100 series covering common standards for tactical and long haul communications, a MIL-STD-188-200 series covering standards for tactical communications only, and a MIL-STD-188-300 series covering standards for long haul communications only. Emphasis is being placed on developing common standards for tactical and long haul communications published in the MIL-STD-188-100 series.
4. This standard contains technical parameters for digital facsimile equipment -used in tactical and long haul communications. The parameters contained herein are compatible with the mandatory parameters of Standardization Agreement (STANAG) 5000 and CCITT Group 3 equipment.
5. This document provides mandatory system standards for planning, engineering, procurement and use of digital facsimile equipment capabilities for DOD digital communication systems.

MIL-STD-188-161A

INTERNATIONAL STANDARDIZATION AGREEMENT.

Certain provisions of this standard are the subject of international standardization agreement STANAG 5000. When amendment, revision, or cancellation of this standard is proposed which will modify the international agreement concerned, the preparing activity will take appropriate action through international standardization channels including departmental standardization offices to change the agreement or make other appropriate accommodation.

MIL-STD-188-161A

CONTENTS

Paragraph		Page
1	SCOPE.....	1
1.1	Purpose.....	1
1.2	Contents.....	1
1.3	Applications.....	1
1.4	Objective.....	1
1.5	System standards and design objective.....	1
2	REFERENCE DOCUMENTS.....	3
2.1	Government documents.....	3
2.1.1	Standards.....	3
2.1.2	Other government documents and publications.....	3
2.2	Other publications.....	3
2.3	Order of precedence.....	4
3	DEFINITIONS.....	5
3.1	Facsimile equipment type definitions.....	5
3.1.1	Type I facsimile equipment.....	5
3.1.2	Type II facsimile equipment.....	5
3.1.3	CCITT Group 3 equipment.....	5
3.2	Facsimile mode definitions.....	5
3.2.1	Basic mode.....	5
3.2.2	Handshake mode.....	5
3.3	Synchronization code words and signaling sequences.....	5
3.4	Other definitions.....	5
4	GENERAL REQUIREMENTS.....	7
4.1	Interoperability.....	7
4.2	TEMPEST.....	7
5	DETAILED REQUIREMENTS.....	8
5.1	Interface.....	8
5.1.1	Transmission rates.....	8
5.1.2	Digital interfaces.....	8
5.1.3	Interchange circuits.....	8
5.2	Type I facsimile equipment.....	8
5.2.1	Image parameters.....	8
5.2.1.1	Tolerance.....	8
5.2.1.2	Scan line length.....	8
5.2.1.3	Resolution.....	8
5.2.1.4	Scanning direction.....	9
5.2.1.5	Scanned line transmission time.....	9
5.2.1.6	Contrast levels.....	9

MIL-STD-188-161A

CONTENTS (Continued)

Paragraph		Page
5.2.2	Document dimensions.....	9
5.2.3	Image coding modes.....	9
5.2.3.1	Uncompressed mode.....	9
5.2.3.2	Compressed mode.....	9
5.2.3.2.1	Short runs.....	10
5.2.3.2.2	Long runs.....	10
5.2.3.2.3	End of line (EOL).....	10
5.2.3.2.4	Fill.....	10
5.2.3.2.5	Return to control (RTC).....	10
5.2.3.3	Compressed with forward error correction.....	10
5.2.3.3.1	Encoder.....	13
5.2.3.3.2	Decoder.....	13
5.2.3.3.3	Interleaving buffer.....	13
5.2.3.3.4	Synchronization.....	13
5.2.4	Loss of facsimile synchronization.....	17
5.2.5	Signaling protocols.....	17
5.2.5.1	Protocol elements and frames.....	17
5.2.5.1.1	Synchronization code words.....	17
5.2.5.1.2	Start of message (SOM).....	19
5.2.5.1.3	End of message (EOM).....	19
5.2.5.2	Signaling sequence and timing.....	19
5.2.5.2.1	Compressed, forward error correction (FEC) not used.....	19
5.2.5.2.2	Compressed, FEC used.....	23
5.2.5.2.3	Uncompressed.....	23
5.2.5.3	Handshake mode protocols.....	23
5.2.5.3.1	Timing.....	25
5.2.5.3.2	Format.....	25
5.2.5.3.3	Acknowledgment.....	25
5.2.5.3.4	Response.....	25
5.2.5.3.5	End of message.....	25
5.2.5.3.6	Full duplex.....	25
5.2.5.4	Extended protocols.....	25
5.3	Type II facsimile equipment.....	29
5.3.1	Image parameters.....	29
5.3.2	Black and white operation.....	29
5.3.3	Gray scale operation.....	29
5.3.3.1	Gray-coding the gray scale.....	29
5.3.3.2	Bit plane encoding the gray scale.....	29
5.3.3.3	Gray scale transmission.....	31
5.3.3.3.1	Uncompressed.....	31
5.3.3.3.2	Compressed.....	31
5.3.3.3.2.1	Compressed data format.....	31

MIL-STD-188-161A

CONTENTS (Continued)

Paragraph		Page
5.3.3.3.2.2	Scan line pair.....	31
5.3.3.3.2.3	Wobbled scan lines.....	32
5.3.3.3.2.4	Variable length code words.....	32
5.3.3.3.2.5	Run-length representation.....	32
5.3.3.3.3	Auto resolution.....	32
5.3.3.3.3.1	Auto resolution algorithm.....	35
5.3.3.3.3.2	Transmitter.....	35
5.3.3.3.3.3	Receiver.....	35
5.3.3.3.3.4	Signaling the auto resolution mode.....	35
5.3.3.3.3.5	Beginning of line pair (BOLP).....	35
5.3.3.3.3.6	Begining of intermediate line pair (BILP).....	35
5.3.3.3.3.7	Fill.....	37
5.3.3.3.3.8	Return to control (RTC).....	37
5.3.3.3.4	Compressed with forward error correction(FEC).....	37
5.3.4	Loss of facsimile synchronization.....	37
5.3.5	Signaling protocols.....	37
5.3.5.1	Synchronization code words.....	37
5.3.5.1.1	Start of message (SOM)	37
5.3.5.1.2	End of message (EOM).....	37
5.3.5.2	Signaling sequence and timing.....	38
5.3.5.3	Handshake mode protocol.....	38
5.3.5.4	Extended protocols.....	38
6	KEY WORDS.....	39
6.1	Key word list.....	39

FIGURES

Figure		Page
1	Interleaving buffer at the transmitter.....	15
2	Interleaving buffer at the receiver.....	15
3	Synchronization SOM sequence for BCH coder and interleaver.....	16
4	Value allocations for the command SOM frame.....	20
5	Signal timing, compressed mode, FEC not used.....	21
6	Signal timing, compressed mode, FEC used.....	24
7	Signal timing, uncompressed mode.....	24
8	Signal timing, handshake mode, FEC used.....	24
9	Signal timing, handshake mode, FEC not used.....	26

MIL-STD-188-161A

CONTENTS (Continued)

Figure		Page
10	Transmission of HSOM within a line of uncompressed data.....	27
11	Transmission of the HSOM within a line of gray scale compressed data.....	27
12	Value allocations for response SOM frame.....	28
13	Encoded scan line pair of 16 gray shades starting at the beginning of a page.....	30
14	Example of an encoded scan line pair showing the last scan line pair of a page.....	33
15	Bit plane wobble data format.....	34

TABLES

Table		Page
I	Code words and signaling sequences.....	6
II	Functional interchange circuits.....	8
III	Terminating codes.....	11
IV	Make-up codes.....	12
V	Syndromes of the BCH decoder.....	14
VI	Protocol elements.....	18
VII	X values with corresponding binary descriptor....	22
VIII	Normalized gray scale shades.....	28
IX	Gray-codes for 4, 8, and 16 gray shades.....	30
X	Bit plane vs auto resolution function.....	36
XI	Auto resolution - signaling codes.....	36

MIL-STD-188-161A

CONTENTS (Continued)

APPENDIXES

Appendix		Page
A.	Memorandum from Under Secretary of Defense, Research and Engineering, 16 August 1983, Subject: Mandatory Use of Military Tele- communications Standards in the MIL-STD-188 Series.....	41
B.	Abbreviations and Acronyms.....	43
C.	Suggested Implementations for Digital Facsimile..	47

MIL-STD-188-161A

This page intentionally left blank.

MIL-STD-188-161A

1. SCOPE

1.1 Purpose. The purpose of this document is to promulgate technical interoperability and performance parameters in the form of mandatory system standards and optional design objectives that are considered necessary to ensure compatibility and commonality among digital facsimile equipment. It is also the purpose of this document to establish a level of performance for digital facsimile equipment considered necessary to satisfy the requirements of a majority of users. The technical parameters promulgated by this document represent, in general, minimum interoperability and performance characteristics which may be exceeded in order to satisfy specific requirements.

It is not the purpose of this document to serve as a stand-alone, comprehensive reference containing all technical parameters and other details required for the design of new equipment or the preparation of specifications. Therefore, parameters for such items as size and weight limitations, connectors, cable assemblies, or power supplies are not contained in this document. These parameters and other design details have to be established, based on specific requirements, and have to be carefully tailored in accordance with the policies of Department of Defense Directive (DODD) 4120.21 and MIL-STD-188-100.

This document is not intended to be an engineering textbook for a reference for digital facsimile equipment. It is assumed that users of this document have a basic technical background in the design and engineering of digital facsimile systems.

It is not the purpose of this document to inhibit advances in communications technology. Such advances are facilitated by not specifying the technology that should be used in the design and development of digital facsimile systems to meet the required standards.

1.2 Content. This standard provides technical interoperability and performance parameters for two types of digital facsimile equipment. These types are designated Type I and Type II, which are compatible with Type I and Type II NATO tactical digital facsimile equipment, respectively. This standard also includes requirements for CCITT Group 3 facsimile equipment in accordance with FED-STD-1062 and FED-STD-1063.

1.3 Applications. This document applies to the design and development of new facsimile equipment.

MIL-STD-188-161A

1.4 Objective. The main objectives of this document are to ensure interoperability of digital facsimile equipment consistent with DOD requirements, to provide a degree of performance acceptable to a majority of users of digital facsimile equipment, and to achieve the necessary degree of interoperability, performance and compatibility in the most economical way.

1.5 System standards and design objective. The parameters and other requirements specified in this document are mandatory system standards if the word "shall" is used in connection with the parameter value or requirement under consideration. Nonmandatory design objectives are indicated by parenthesis after a standardized parameter value or by the word "should" in connection with the parameter value or requirement under consideration. For a definition of the terms "system standard" and "design objective" see Federal Standard (FED-STD) 1037A.

MIL-STD-188-161A

2. REFERENCE DOCUMENTS

2.1 Government documents.

2.1.1 Standards. Unless otherwise specified, the following standards of the issue listed in that issue of the Department of Defense Index of Specifications and Standards (DODISS) specified in the solicitation form a part of this standard to the extent specified herein.

Federal standards

FED-STD-1037A	Glossary of Telecommunication Terms
FED-STD-1062	Adoption of EIA-465
FED-STD-1063	Adoption of EIA-466

Military standards

MIL-STD-188-100	Common Long Haul and Tactical Communications Systems Technical Standards
MIL-STD-188-114	Electrical Characteristics of Digital Interface Circuits
MIL-STD-461B	Electromagnetic Emission and Susceptibility Requirements for the Control of Electromagnetic Interference

2.1.2 Other government documents and publications. The following government documents, drawings, and publications form a part of this standard to the extent specified herein.

NACSIM 5100 (CURRENT EDITION)	Compromising Emanations Laboratory Test Standard, Electromagnetics (U)
DODD 4120.21	Application and Specifications Standards and Related Documents in the Acquisition Process

(Copies of specifications, standards, drawings, and publications required by contractors in connection with specific procurement functions should be obtained from the procuring activity or as directed by the contracting officer.)

2.2 Other publications. The following documents form a part of this standard to the extent specified herein. Unless otherwise specified, the issues of the documents which are DOD adopted shall be those listed in the issue of the DODISS specified in the solicitation. The issues

MIL-STD-188-161A

of documents which have not been adopted shall be those in effect on the date of the cited DODISS.

STANAG 5000	Interoperability of Tactical Digital Facsimile Equipment
CCITT RED BOOK VOL. VII	
Recommendation T.4	Standardization of Group 3 Facsimile Apparatus for Document Transmission
Recommendation T.30	Procedures for Document Facsimile Transmission in the General Switched Telephone Network

(Applications for copies should be addressed to the U.S. Department of Commerce, National Technical Information Service, 5285 Port Royal Road, Springfield, VA 22161.)

(Nongovernment standards are generally available for reference from libraries. They are also distributed among nongovernment standards bodies and using Federal agencies.)

2.3 Order of precedence. In the event of a conflict between the text of this standard and the references cited herein, the text of this standard shall take precedence.

MIL-STD-188-161A

3. DEFINITIONS

3.1 Facsimile equipment type definitions.

3.1.1 Type I facsimile equipment. Facsimile equipment which provides for the transmission and reception of an image with black and white information only is called Type I facsimile equipment. This equipment is compatible with Type I NATO facsimile equipment as defined in STANAG 5000.

3.1.2 Type II facsimile equipment. Facsimile equipment which provides for the transmission and reception of an image in shades of gray, as well as black and white, is called Type II facsimile equipment. This equipment is compatible with Type II NATO Facsimile equipment as defined in STANAG 5000.

3.1.3 CCITT Group 3 equipment. Facsimile equipment which provides for the transmission and reception of an image with black and white information as defined in CCITT Recommendations T.4 and T.30 (FED-STD-1062 and FED-STD-1063), which incorporate means for reducing the redundant information in the document signal using the coding scheme defined in CCITT Recommendation T.4 prior to the modulation process.

3.2 Facsimile mode definitions.

3.2.1 Basic mode. In the basic mode the transmitter for Type I and Type II does not pause after calling the receiving unit to wait for an acknowledgment before transmitting an image in the simplex and broadcast mode of operation.

3.2.2 Handshake mode. In the handshake mode the transmitter for Type I, Type II, and CCITT Group 3 pauses after calling the receiving unit to wait for an acknowledgment before transmitting an image in the duplex mode of operation.

NOTE: This is a normal method of operation for CCITT Group 3 facsimile equipment.

3.3 Synchronization code words and signaling sequences. The code words and signaling sequences used in Type I and Type II facsimile are defined in table I.

3.4 Other definitions. Other telecommunication terms used in this document are defined in FED-STD-1037A.

MIL-STD-188-161A

TABLE I. Code words and signaling sequences.

Name	Make Up
Beginning of Intermediate Line Pair (BILP)	0000000000000011
Beginning of Line Pair (BOLP)	0000000000000010
End of Line (EOL)	000000000001
End of Message (EOM)	16 consecutive S_1 code words
Not End of Message (EOM)	16 consecutive inverted S_1 code words
Return to Control (RTC)	EOL EOL EOL EOL EOL EOL
Start of Message (SOM)	S_1 S_0 X clock periods S_0 S_1 (Where X is the number of clock periods between the pairs of code words)
S_0	111100010011010
S_1	111101011001000
Fill	Variable length string of 0s
Stuffing	Variable length string of 1s
Preamble	Variable length string of all 1s or all 0s

MIL-STD-188-161A

4. GENERAL REQUIREMENTS

4.1 Interoperability. The overriding requirement is for interoperability within DOD, among all Services and Agencies and with our NATO allies. The facsimile equipment shall be compatible with NATO facsimile equipment that follows STANAG 5000. All facsimile equipment shall also include CCITT Group 3 interoperability signaling protocols (T.30) to ensure interoperability. The facsimile equipment shall be compatible with the requirements documented in FED-STD-1062 and FED-STD-1063. (Note: MIL-STD-188-161A is compatible with STANAG 5000 requirements.)

4.1.1. Protocols. STANAG 5000 protocols shall always be used between terminals implementing both CCITT Group 3 and STANAG 5000 protocols. (Note: There is no requirement for the CCITT Group 3 T.30 protocols and STANAG 5000 protocols to interoperate.)

4.2 TEMPEST. The facsimile equipment, when provided for secure operations, shall be designed to meet all applicable requirements of the current version of NACSIM 5100.

MIL-STD-188-161A

5. DETAILED REQUIREMENTS

5.1 Interface.

5.1.1 Transmission rates. The facsimile equipment shall be able to operate bit-by-bit asynchronously at data rates of 2400 bits per second, 4800 bits per second, 9600 bits per second, 16000 bits per second and 32 kilobits per second (kb/s) with timing provided by an external clock.

5.1.2 Digital interfaces. The electrical characteristics of all digital interfaces for data, control, and timing signals shall comply with the applicable requirements as stated in MIL-STD-188-114.

5.1.3 Interchange circuits. The interchange circuits shown in table II are mandatory. Other circuits may be provided for specific applications.

TABLE II. Functional interchange circuits.

CIRCUIT	DIRECTION
REQUEST TO SEND	FROM DTE TO DCE
CLEAR TO SEND	FROM DCE TO DTE
RECEIVE INPUT CONTROL	FROM DTE TO DCE
SEND DATA	FROM DTE TO DCE
RECEIVE DATA	FROM DCE TO DTE
SEND TIMING	FROM DCE TO DTE
RECEIVE TIMING	FROM DCE TO DTE
SEND COMMON	RETURN
RECEIVE COMMON	RETURN
SIGNAL GROUND	GROUND

5.2 Type I facsimile equipment.5.2.1 Image parameters.

5.2.1.1 Tolerance. The tolerance for the image parameters listed in subparagraphs 5.2.1.2 and 5.2.1.3, shall be ± 1 percent.

5.2.1.2 Scan line length. The scan line length shall be 215 millimeters (mm), left justified.

5.2.1.3 Resolution. The facsimile equipment shall have three switch selectable standards for vertical and horizontal resolution. They are:

MIL-STD-188-161A

a. 3.85 lines per mm (vertical) by 1728 black and white picture elements (pels) along the horizontal scan line. (Note: This is a nominal medium resolution of 100 by 200 lines per inch.)

b. 3.85 lines per mm (vertical) by 864 black and white pels along the horizontal scan line. (Note: This is a nominal low resolution of 100 by 100 lines per inch.)

c. 7.7 lines per mm by 1728 pels along the horizontal scan line. (Note: This is a nominal high resolution of 200 by 200 lines per inch.)

5.2.1.4 Scanning direction. Scanning direction shall be from left to right and from top to bottom.

5.2.1.5 Scanned line transmission time. The minimum scanned line transmission time shall be 20 milliseconds (msec).

5.2.1.6 Contrast levels. The contrast levels shall be black and white.

5.2.2 Document dimensions. Input of documents up to a maximum of 215 mm wide by 1000 mm long shall be accepted. Documents up to 230 mm wide may be accepted into the scanner but only 215 mm of the document shall be scanned.

5.2.3 Image coding modes. The facsimile equipment shall be capable of operating in three modes: uncompressed, compressed, and compressed with forward error correction. (Note: Simplified block diagrams of the facsimile transmitter and receiver are shown in Appendix C.) Subparagraphs 5.2.3.1 through 5.2.3.3 apply to resolutions of x 200 (1728 pels). The same principles apply to the resolutions of x 100 (864 pels).

5.2.3.1 Uncompressed mode. In the uncompressed mode, facsimile data shall be transmitted pel by pel, with logic 1 representing black. Each line of the output data shall consist of a synchronization code followed by a number of pels as specified in subparagraph 5.2.1.3. The synchronization code shall be a sequence of two S_0 code words.

5.2.3.2 Compressed mode. In the compressed mode, facsimile data shall be transmitted after compression by the redundancy reduction algorithm. A line of data shall be composed of a series of variable length code words. Each code word represents a run-length of either all white or all black. White runs and black runs shall alternate. All data lines shall begin with a white run-length code word to ensure that the

MIL-STD-188-161A

receiver maintains color synchronization. A white run-length of zero shall be sent if the actual scan line begins with a black run. Black or white run-lengths, up to a maximum length of one scanning line (1728 pels), are defined by the code words in tables III and IV. The code words are of two types: terminating code words and make-up code words. Each run-length shall be represented by either one terminating code word, or one make-up code word followed by a terminating code word.

5.2.3.2.1 Short runs. Run-lengths in the range of 0 through 63 pels shall be encoded with the appropriate terminating code word. (Note: The black run-length code words and the white run-length code words are in separate lists.

5.2.3.2.2 Long runs. Run-lengths in the range of 64 through 1728 pels shall be encoded first by the make-up code word representing the run-length which is equal to or shorter than that required. The make-up code word shall be followed by the terminating code word representing the difference between the required run-length and the run-length represented by the make-up code word.

5.2.3.2.3 End of line (EOL). The EOL code word shall follow each line of facsimile data. (Note: This is a unique code word that can never be found within a valid line of data. Therefore, resynchronization after an error burst is possible.) In addition, the EOL code word shall also be sent prior to the first data line of a page.

5.2.3.2.4 Fill. Fill may be placed in the data flow to generate a pause. Fill may be inserted between a line of data and an EOL, but never within a line of data. Fill shall be added to ensure that the transmission time of each total coded scan line is not less than the minimum. To prevent premature disconnects, the maximum transmission time of any total coded scan line should be less than the interval specified in the loss of synchronization specifications. (Note: Fill format is a variable length string of 0s.)

5.2.3.2.5 Return to control (RTC). A minimum of two RTC signals shall be sent to indicate the end of document transmission. (Note: Each RTC consists of six consecutive EOLs.) Following the RTC signals, the transmitter shall send the post-message commands.

5.2.3.3 Compressed with forward error correction. In the compressed with forward error correction mode, facsimile data shall be further processed by a channel coder and bit interleaving buffer to provide forward error correction (FEC). The channel coder shall use a Bose Chandhuri Hocquenghem (BCH) forward error correction code with the

MIL-STD-188-161A

TABLE III. Terminating codes.

White run length	Code word	Black run length	Code word
0	00110101	0	0000110111
1	000111	1	010
2	0111	2	11
3	1000	3	10
4	1011	4	011
5	1100	5	0011
6	1110	6	0010
7	1111	7	00011
8	10011	8	000101
9	10100	9	000100
10	00111	10	0000100
11	01000	11	0000101
12	001000	12	0000111
13	000011	13	00000100
14	110100	14	00000111
15	110101	15	000011000
16	101010	16	0000010111
17	101011	17	0000011000
18	0100111	18	0000001000
19	0001100	19	00001100111
20	0001000	20	00001101000
21	0010111	21	00001101100
22	0000011	22	00000110111
23	0000100	23	00000101000
24	0101000	24	00000010111
25	0101011	25	00000011000
26	0010011	26	000011001010
27	0100100	27	000011001011
28	0011000	28	000011001100
29	00000010	29	000011001101
30	00000011	30	000001101000
31	00011010	31	000001101001
32	00011011	32	000001101010
33	00010010	33	000001101011
34	00010011	34	000011010010
35	00010100	35	000011010011
36	00010101	36	000011010100
37	00010110	37	000011010101
38	00010111	38	000011010110
39	00101000	39	000011010111
40	00101001	40	000001101100
41	00101010	41	000001101101
42	00101011	42	000011011010
43	00101100	43	000011011011
44	00101101	44	000001010100
45	00000100	45	000001010101
46	00000101	46	000001010110
47	00001010	47	000001010111
48	00001011	48	000001100100
49	01010010	49	000001100101
50	01010011	50	000001010010
51	01010100	51	000001010011
52	01010101	52	000000100100
53	00100100	53	000000110111
54	00100101	54	000000111000
55	01011000	55	000000100111
56	01011001	56	000000101000
57	01011010	57	000001011000
58	01011011	58	000001011001
59	01001010	59	000000101011
60	01001011	60	000000101100
61	00110010	61	000001011010
62	00110011	62	000001100110
63	00110100	63	000001100111

Note: These codes are identical to those of CCITT Recommendation T.4 of the Red Book.

MIL-STD-188-161A

TABLE IV. Make-up codes.

White run length	Code word	Black run length	Code word
64	11011	64	0000001111
128	10010	128	000011001000
192	010111	192	000011001001
256	0110111	256	000001011011
320	00110110	320	000000110011
384	00110111	384	000000110100
448	01100100	448	000000110101
512	01100101	512	0000001101100
576	01101000	576	0000001101101
640	01100111	640	0000001001010
704	011001100	704	0000001001011
768	011001101	768	0000001001100
832	011010010	832	0000001001101
896	011010011	896	0000001110010
960	011010100	960	0000001110011
1024	011010101	1024	0000001110100
1088	011010110	1088	0000001110101
1152	011010111	1152	0000001110110
1216	011011000	1216	0000001110111
1280	011011001	1280	0000001010010
1344	011011010	1344	0000001010011
1408	011011011	1408	0000001010100
1472	010011000	1472	0000001010101
1536	010011001	1536	0000001011010
1600	010011010	1600	0000001011011
1664	011000	1664	0000001100100
1728	010011011	1728	0000001100101
E O L	000000000001	E O L	000000000001

Note: These codes are identical to those of CCITT Recommendation T.4 of the Red Book.

MIL-STD-188-161A

capability of correcting two errored bits per block. Table V lists the syndromes of the BCH code that shall be used.

5.2.3.3.1 Encoder. An encoder shall be provided in the facsimile transmitter to encipher the facsimile data using the BCH code. For information on possible implementation of the encoder see Appendix C.

5.2.3.3.2 Decoder. A decoder shall be provided in the facsimile receiver to decode the enciphered facsimile data. For information on possible implementation of the decoder see Appendix C.

5.2.3.3.3 Interleaving buffer. An interleaving buffer shall be used to improve the error correcting capability of the channel encoder, especially considering transmission bit errors clustered in bursts. The buffer shall be a matrix of $63 \times 5 = 315$ bits. Figure 1 shows the interleaving buffer configuration on the transmitting side. (Note: The figure labeling follows STANAG 5000 format, hence the long side of the matrix is designated N ($N = 63$) and the short side is designated W ($W = 5$.) Data input shall be line-by-line, data output shall be column-by-column. The data input sequence shall be

$$D_0, D_1, \dots, D_{313}, D_{314}.$$

Accordingly, the data output sequence shall be:

$$D_0, D_{63}, D_{126}, D_{189}, D_{252}, D_1, D_{64}, \dots, D_{188}, D_{251}, D_{314}.$$

At the receiving side, the data input and data output sequence shall be the reverse of the transmitting side (as shown in figure 2).

5.2.3.3.4 Synchronization. The transmitting BCH-encoder and interleaving buffer respectively shall be synchronized with the receiving BCH-decoder and interleaving buffer, before starting the transmission of encoded facsimile data. The FEC control block shall be the synchronization SOM sequence when the BCH-encoder and interleaving buffer are used. Figure 3 illustrates the format for the synchronization SOM sequence. The synchronization process shall be as follows:

a. The transmitter shall send the synchronization SOM sequence without using the BCH-encoder and interleaving buffer. Immediately after the synchronization SOM sequence, the transmitter uses the BCH-encoder and interleaving buffer to send encoded facsimile data.

b. At the receiver, the incoming signal shall be initially monitored bit-by-bit without using the BCH-decoder and interleaving buffer. When the first synchronization SOM sequence is detected,

MIL-STD-188-161A

TABLE V. Syndromes of the BCH decoder.

	r11	r10	r9	r8	r7	r6	r5	r4	r3	r2	r1	r0
R1	1	0	0	0	0	0	0	0	0	0	0	0
R2	1	1	0	0	0	0	0	0	0	0	0	0
R3	1	0	1	0	0	0	0	0	0	0	0	0
R4	1	0	0	1	0	0	0	0	0	0	0	0
R5	1	0	0	0	1	0	0	0	0	0	0	0
R6	1	0	0	0	0	1	0	0	0	0	0	0
R7	1	0	0	0	0	0	1	0	0	0	0	0
R8	1	0	0	0	0	0	0	1	0	0	0	0
R9	1	0	0	0	0	0	0	0	1	0	0	0
R10	1	0	0	0	0	0	0	0	0	1	0	0
R11	1	0	0	0	0	0	0	0	0	0	1	0
R12	1	0	0	0	0	0	0	0	0	0	0	1
R13	0	0	1	0	1	0	0	1	1	1	0	0
R14	1	1	0	1	0	1	0	0	1	1	1	0
R15	1	0	1	0	1	0	1	0	0	1	1	1
R16	0	0	1	1	1	1	0	0	1	1	1	1
R17	0	1	1	1	0	1	1	1	1	0	1	1
R18	0	1	0	1	0	0	1	0	0	0	0	1
R19	0	1	0	0	0	0	0	0	1	1	0	0
R20	1	1	1	0	0	0	0	0	0	1	1	0
R21	1	0	1	1	0	0	0	0	0	0	1	1
R22	0	0	1	1	0	0	0	1	1	1	0	1
R23	0	1	1	1	0	0	0	1	0	0	1	0
R24	1	1	1	1	1	0	0	0	1	0	0	1
R25	0	0	0	1	0	1	0	1	1	0	0	0
R26	1	1	0	0	1	0	1	0	1	1	0	0
R27	1	0	1	0	0	1	0	1	0	1	1	0
R28	1	0	0	1	0	0	1	0	1	0	1	1
R29	0	0	1	0	0	0	0	0	1	0	0	1
R30	0	1	1	1	1	0	0	1	1	0	0	0
R31	1	1	1	1	1	1	0	0	1	1	0	0
R32	1	0	1	1	1	1	1	0	0	1	1	0
R33	1	0	0	1	1	1	1	1	0	0	1	1
R34	0	0	1	0	0	1	1	0	0	1	0	1
R35	0	1	1	1	1	0	1	0	1	1	1	0
R36	1	1	1	1	1	1	0	1	0	1	1	1
R37	0	0	0	1	0	1	1	1	0	1	1	1
R38	0	1	1	0	0	0	1	0	0	1	1	1
R39	0	1	0	1	1	0	0	0	1	1	1	1
R40	0	1	0	0	0	1	0	1	1	0	1	1
R41	0	1	0	0	1	0	1	1	0	0	0	1
R42	0	1	0	0	1	1	0	0	0	1	0	0
R43	1	1	1	0	0	1	1	0	0	0	1	0
R44	1	0	1	1	0	0	1	1	0	0	0	1
R45	0	0	1	1	0	0	0	0	0	1	0	0
R46	1	1	0	1	1	0	0	0	0	0	1	0
R47	1	0	1	0	1	1	0	0	0	0	0	1
R48	0	0	1	0	1	1	1	1	1	1	0	0
R49	1	1	0	1	1	1	1	1	1	1	1	0
R50	1	0	1	0	1	1	1	1	1	1	1	1
R51	0	0	1	1	1	1	1	0	0	0	1	1
R52	0	1	1	1	0	1	1	0	1	1	0	1
R53	0	1	0	1	0	0	1	0	1	0	1	0
R54	1	1	1	0	1	0	0	1	0	1	0	1
R55	0	0	0	1	1	1	0	1	0	1	1	0
R56	1	1	0	0	1	1	1	0	1	0	1	1
R57	0	0	0	0	1	1	1	0	1	0	0	1
R58	0	1	1	0	1	1	1	0	1	0	0	0
R59	1	1	1	1	0	1	1	1	0	1	0	0
R60	1	0	1	1	1	0	1	1	1	0	1	0
R61	1	0	0	1	1	1	0	1	1	1	0	1
R62	0	0	1	0	0	1	1	1	0	0	1	0
R63	1	1	0	1	0	0	1	1	1	0	0	1

MIL-STD-188-161A

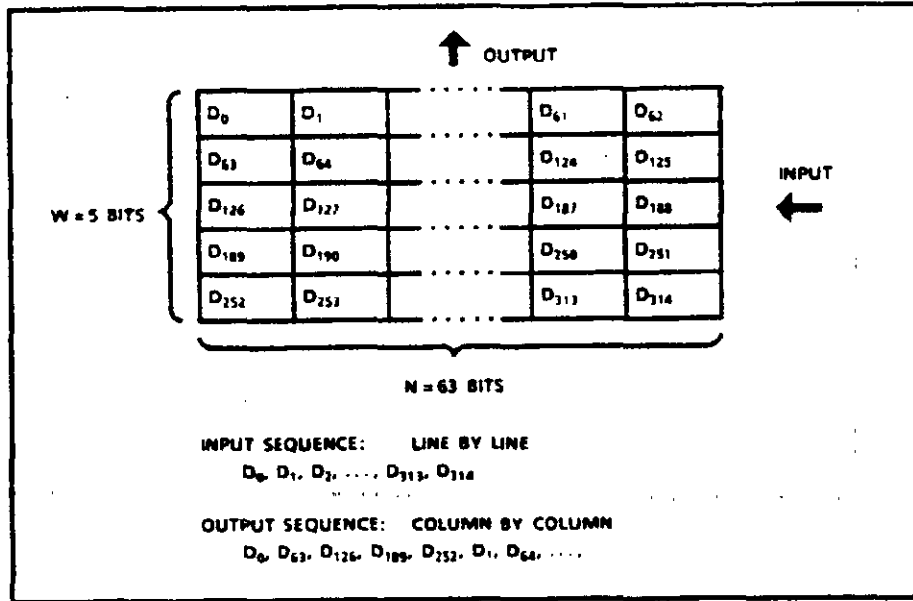

FIGURE 1. Interleaving buffer at the transmitter.

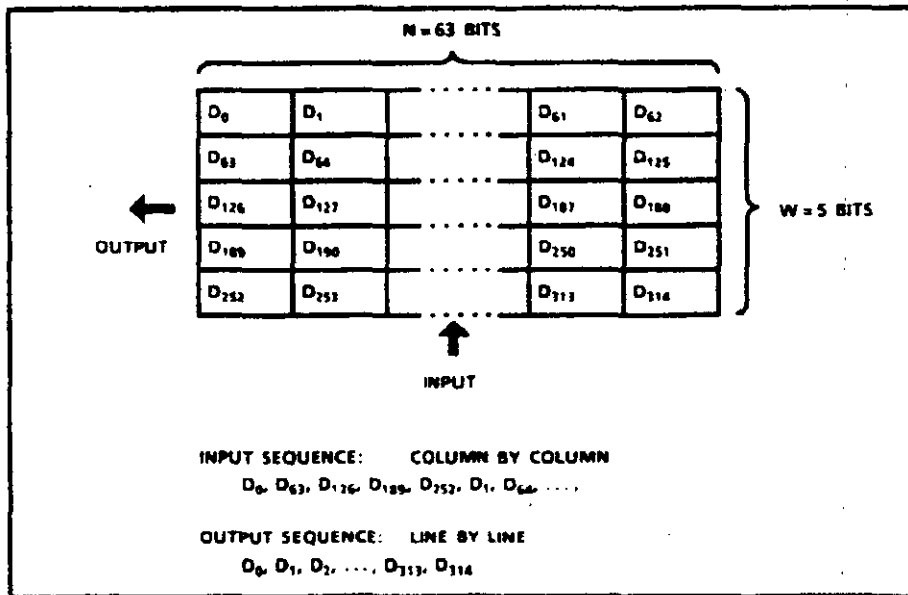
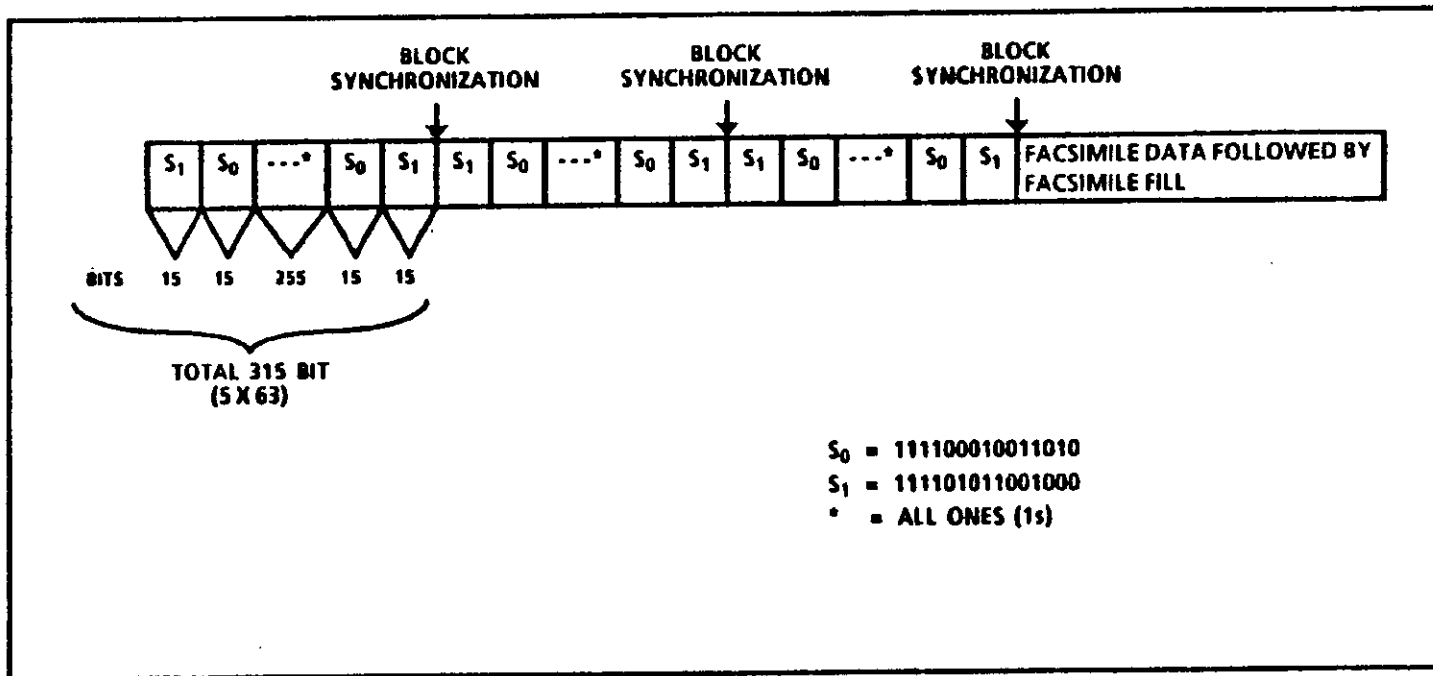

FIGURE 2. Interleaving buffer at the receiver.



MIL-STD-188-161A

FIGURE 3. Synchronization SOM sequence for BCH coder and interleaver.

MIL-STD-188-161A

synchronization is achieved and, thereafter, the BCH-encoder and interleaving buffer shall be used. Block synchronization can be achieved at any of the three points illustrated in figure 3. After the detection of any block synchronization point, incoming data shall pass through the BCH-decoder and interleaving buffer to the source decoder.

5.2.4 Loss of facsimile synchronization. In the event of the loss of the synchronization signal, the receiver shall be capable of detecting loss of synchronization. At any time following detection of the first synchronization signal, the receiver shall declare a loss of synchronization if a line synchronization code or an EOM has not been detected within a time-out period. This period shall be sufficiently long to preclude false declaration of loss of synchronization. The signal indicating the loss shall be an "on" state, as defined by MIL-STD-188-114, applied to the loss of synchronization interchange circuit. (Note: Implementation of this feature is a performance factor and does not bear directly on interoperability.)

5.2.5 Signaling protocols. Signaling protocol frames shall be used to coordinate message transmission. The parameters to be used for each transmission shall be signaled to the receiver using SOM frames and the termination of the facsimile transmission shall be signaled by an EOM sequence. STANAG 5000 protocols shall always be used for digital secure operation. (Note: The protocol signals have been specifically designed to provide extremely high assurance of correct receiver operation (automatic start, mode setup, and automatic stop) in error environments as high as a 10^{-2} bit error rate (BER). This means that a return acknowledgment is not necessary for the basic mode.)

5.2.5.1 Protocol elements and frames.

5.2.5.1.1 Synchronization code words. Two special synchronization code words shall be used, in various combinations, to generate all protocol requirements. The code words are designated as S_0 and S_1 . Each code word shall be made up of a 15-bit pseudorandom noise (PN) sequence as shown in table I. The composition of the protocol elements in terms of the synchronization code words shall be as shown in table VI. (Note: This lists the probability of detection, P_d , of each protocol element in a noise environment of 10^{-2} BER. All elements have detection probabilities in excess of 99.99 percent in this environment.)

(Note: If either of the PN sequences (code words) are compared, bit-by-bit, with any cyclical shift of the sequence, the number of agreements differs from the number of disagreements by one, except at the autocorrelation peak where there are 15 agreements. Consequently, the correlation improvement for exact synchronization is 15 to 1 for noise-free operation and is reduced by one for every bit perturbed by noise.

MIL-STD-188-161A

TABLE VI. Protocol elements.

Protocol Element	Composition	P_d at 10^{-2} BER	Transmissions Required	Detections Required
SOM	$S_1 S_0 X S_0 S_1$	0.999945	3	1
EOM	S_1	0.99995	16 minimum	4 in sequence

MIL-STD-188-161A

A significant correlation improvement is achieved, even in extremely noisy environments.)

5.2.5.1.2 Start of message (SOM). Each SOM frame shall consist of two pairs of synchronization code words, S_0 and S_1 , separated by an interval measured in clock periods as shown in figure 4. The mode shall be indicated by the number of clock periods (X) between two pairs of code words. The data bit corresponding to each of these clock periods clock shall be logic 1. The binary value allocations for the command SOM frame shall be as shown in figure 4. The value of X to denote the interoperability modes and the corresponding eight-bit binary designators shall be as shown in table VII. The SOM frame shall be transmitted three times but detection by the receiver of any one frame shall be sufficient. Use of these signals is described in paragraph 5.2.5.2.

Note: The value of X can be calculated from the binary value allocations. For example, to obtain the X value corresponding to black and white operation, a resolution of 3.85 lines/mm times 1728 pels/scanline, and compressed mode, assemble the binary designator from the following binary value allocation:

00---001	black and white
00-01---	3.85 lines/mm x 1728 pels/scanline
000-----	compressed mode

The binary designator 001001 is then converted to its decimal equivalent, 9, to get the X value.

5.2.5.1.3 End of message (EOM). The EOM frame shall consist of at least 16 S_1 code words transmitted in sequence. When four consecutive S_1 code words have been detected by the receiver, EOM shall be declared.

5.2.5.2 Signaling sequence and timing.

5.2.5.2.1 Compressed, forward error correction (FEC) not used. Figure 5 illustrates the signaling sequence for the compressed mode without forward error correction. At the start of a document transmission, a short pattern of data shall be sent for the purpose of establishing the data channel (modem training, encryption synchronization, etc.). No constraint shall be placed upon the duration of this phase, but the data transmitted shall conform with the definition of stuffing. With the data communication channel established, the signaling sequence shall begin with at least 16 inverted S_1 code words.

MIL-STD-188-161A

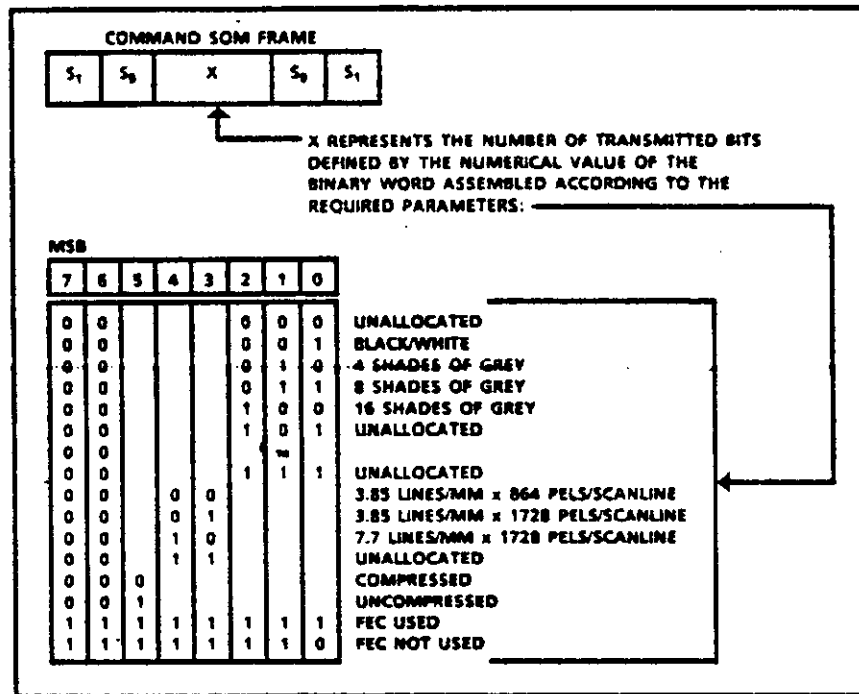

FIGURE 4. Value allocations for the command SOM frame.

MIL-STD-188-161A

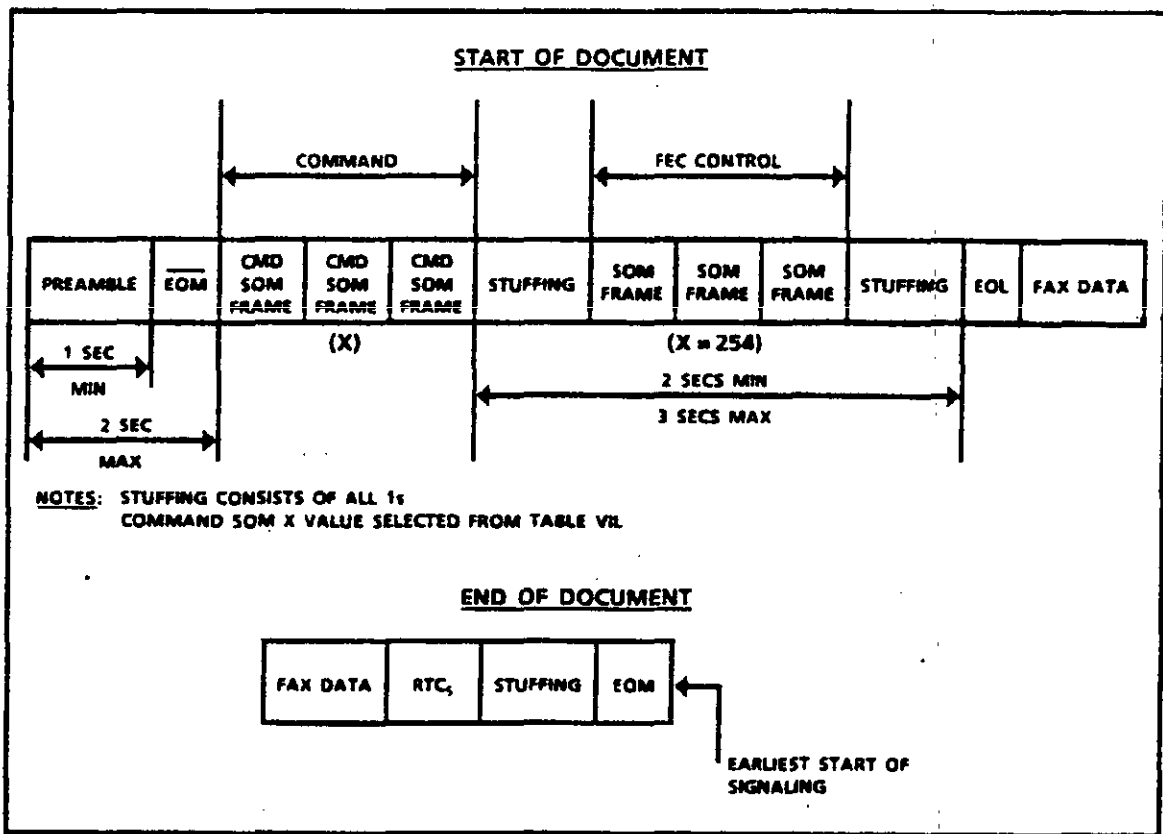

FIGURE 5. Signal timing, compressed mode, FEC not used.

MIL-STD-188-161A

TABLE VII. X values with corresponding binary designator.

COMMAND SOM FRAME PARAMETERS			NO. OF CLOCK PERIODS (X)	BINARY DESIGNATOR							
SHADES OF GRAY	RESOLUTION	COMPRESSION		7	6	5	4	3	2	1	0
BLK/WHT	3.85 x 864 (100 x 100)	C	1	0	0	0	0	0	0	0	1
4			2	0	0	0	0	0	0	1	0
8			3	0	0	0	0	0	0	1	1
16			4	0	0	0	0	0	1	0	0
BLK/WHT	3.85 x 1728 (100 x 200)		9	0	0	0	0	1	0	0	1
4			10	0	0	0	0	1	0	1	0
8			11	0	0	0	0	1	0	1	1
16			12	0	0	0	0	1	1	0	0
BLK/WHT	7.7 x 1728 (200 x 200)		17	0	0	0	1	0	0	0	1
4			18	0	0	0	1	0	0	1	0
8			19	0	0	0	1	0	0	1	1
16			20	0	0	0	1	0	1	0	0
BLK/WHT	3.85 x 864 (100 x 100)	U	33	0	0	1	0	0	0	0	1
4			34	0	0	1	0	0	0	1	0
8			35	0	0	1	0	0	0	1	1
16			36	0	0	1	0	0	1	0	0
BLK/WHT	3.85 x 1728 (100 x 200)		41	0	0	1	0	1	0	0	1
4			42	0	0	1	0	1	0	1	0
8			43	0	0	1	0	1	0	1	1
16			44	0	0	1	0	1	1	0	0
BLK/WHT	7.7 x 1728 (200 x 200)		49	0	0	1	1	0	0	0	1
4			50	0	0	1	1	0	0	1	0
8			51	0	0	1	1	0	0	1	1
16			52	0	0	1	1	0	1	0	0
FEC CONTROL SOM FRAME PARAMETERS			NO. OF CLOCK PERIODS (X)	BINARY DESIGNATOR							
FEC USED				255	1	1	1	1	1	1	1
FEC NOT USED			254	1	1	1	1	1	1	1	0
RESPONSE SOM FRAME PARAMETERS			NO. OF CLOCK PERIODS (X)	BINARY DESIGNATOR							
ACK - EQUIPMENT READY TO RECEIVE				129	1	0	0	0	0	0	0
NAK - EQUIPMENT IS NOT READY			130	1	0	0	0	0	0	1	0
ILL - AN ILLEGAL SOM WAS RECEIVED			131	1	0	0	0	0	0	1	1

MIL-STD-188-161A

(Note: This enables the receiver to correct a channel inversion.) Three command SOM frames with an X value of nine (compressed mode, nominal resolution, black and white), shall be sent next, followed by three FEC control SOM frames with an X value of 254 signifying that FEC will not be used. Stuffing shall be inserted as needed, before and after the FEC control SOM frames. The facsimile data shall start with an EOL code word no less than two seconds and no more than three seconds after the end of the third control SOM frame. At the end of the document, the facsimile data stream shall end with at least two RTC signals. Following RTC, an EOM shall signify the end of the current transmission. Stuffing should be inserted as required between RTC and EOM.

5.2.5.2.2 Compressed, FEC used. Figure 6 illustrates the signaling sequence for the compressed mode with FEC. The data communications channel should be established as described in paragraph 5.2.5.2.1. Inverted S_1 code words shall be sent as defined in paragraph 5.2.5.2.1. Three command SOM frames with an X value of nine shall then be sent followed by three FEC control SOM frames with an X value of 255 to synchronize the FEC system. The insertion and timing of the start of facsimile data shall be as in paragraph 5.2.5.2.1. At the end of the document, the facsimile data shall end with at least two RTC signals. To allow freedom of implementation, EOM shall be sent both before the end and after the end of FEC coding. To ensure that the first EOM can be decoded correctly, the FEC block containing the final bit shall be transmitted in full. Stuffing bits should be inserted as required between RTC and EOM. The second EOM (outside of FEC) shall not commence earlier than 500 msec after the end of the FEC block containing the final bit of RTC. Further signaling may then commence immediately after the second EOM.

5.2.5.2.3 Uncompressed. Figure 7 illustrates the signaling for the uncompressed mode. The data communications channel shall be established as described in paragraph 5.2.5.2.1. Sixteen inverted S_1 code words shall be sent followed by three command SOM frames with an X value of 41. Facsimile data shall follow no less than two seconds and no more than three seconds after the end of the last command SOM. At the end of the document, the facsimile data stream shall end with two seconds of S_1 code words. Further signaling may commence immediately after the S_1 code words. Whenever the receiver does not detect EOM within fifteen seconds after the last line synchronization code, the receiver shall assume that the transmission has terminated and proceed as if it had received an EOM.

5.2.5.3 Handshake mode protocols. This subparagraph provides the details of the handshaking protocols needed for interoperation in the

MIL-STD-188-161A

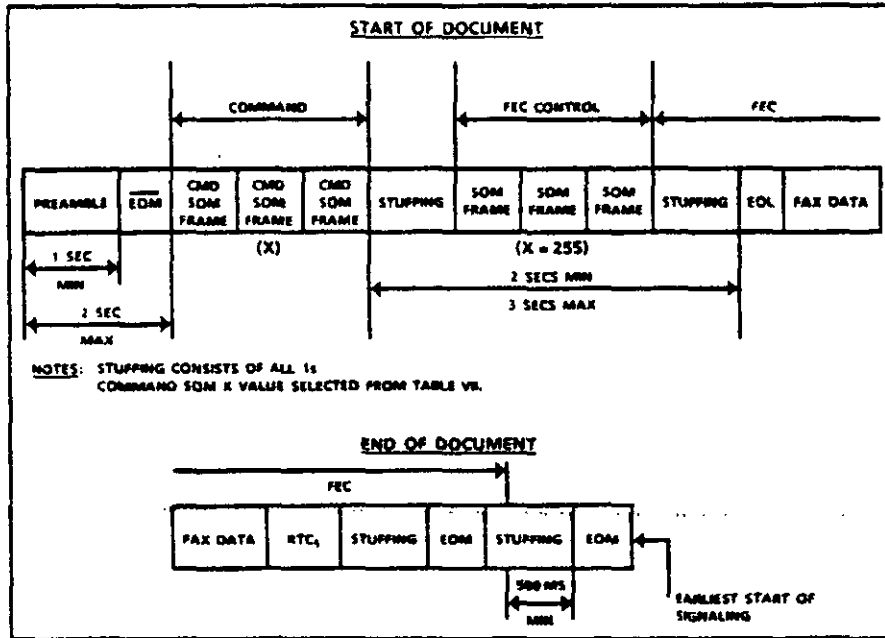

FIGURE 6. Signal timing, compressed mode, FEC used.

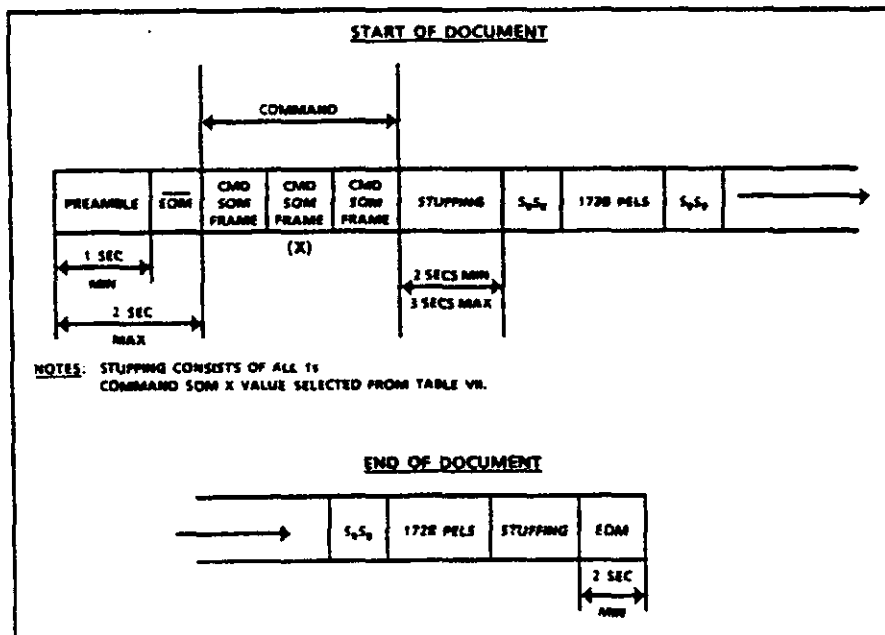

FIGURE 7. Signal timing, uncompressed mode.

MIL-STD-188-161A

handshake mode. Figure 4 shows the X value assignments for the handshake SOM (HSOM) frame.

5.2.5.3.1 Timing. Timing in the handshake mode is more complicated because the sending station shall interrupt transmission after sending the command SOM frames to listen for an acknowledgment. The FEC control SOM frames shall be sent after the receipt of acknowledgment. Figures 8 and 9 illustrate the timing required to transmit HSOM (with FEC enabled or disabled, respectively) when the receiving equipment's transmitter is in the standby mode. Figures 10 and 11 illustrate the timing required to insert the HSOM within a line of facsimile data when the receiving unit is also transmitting data.

5.2.5.3.2 Format. The signal format for the handshake mode shall be the same as described in subparagraph 5.2.5.2.1 up to the end of the third command SOM frame. At this point the transmitter shall prepare to receive an acknowledgment. The signal format of the receiver response acknowledging HSOM shall be the same as the command SOM except for the X values defined in table VII. The binary value allocations for the response SOM frame shall be as shown in figure 12.

5.2.5.3.3 Acknowledgment. When satisfactory acknowledgment is received in a period extending from two to fifteen seconds from the end of the first command SOM frame, then the transmission of facsimile data, including the FEC control SOM frames, shall commence no less than two seconds after the detection of a response SOM frame or no more than three seconds from the last response SOM frame.

5.2.5.3.4 Response. When a response SOM frame is not received within the defined period (see subparagraph 5.2.5.3.3), the equipment shall return to a mode in which it is ready to respond to command SOM frames. Similarly, if a facsimile line synchronization code has not been received within six seconds after transmitting the final response SOM frame, the receiver shall return to the mode where it can respond to command SOM frames.

5.2.5.3.5 End of message. The end of document signal format is the same as in subparagraph 5.2.5.2.3.

5.2.5.3.6 Full duplex. When in full duplex and a transmission is being sent in the opposite direction, the response SOM shall be inserted in the data stream at the end of a line (or a line pair) of data, prior to fill and the line synchronization code word.

5.2.5.4 Extended protocols. Some equipment may require additional protocols for the exchange of status and capabilities in excess of

MIL-STD-188-161A

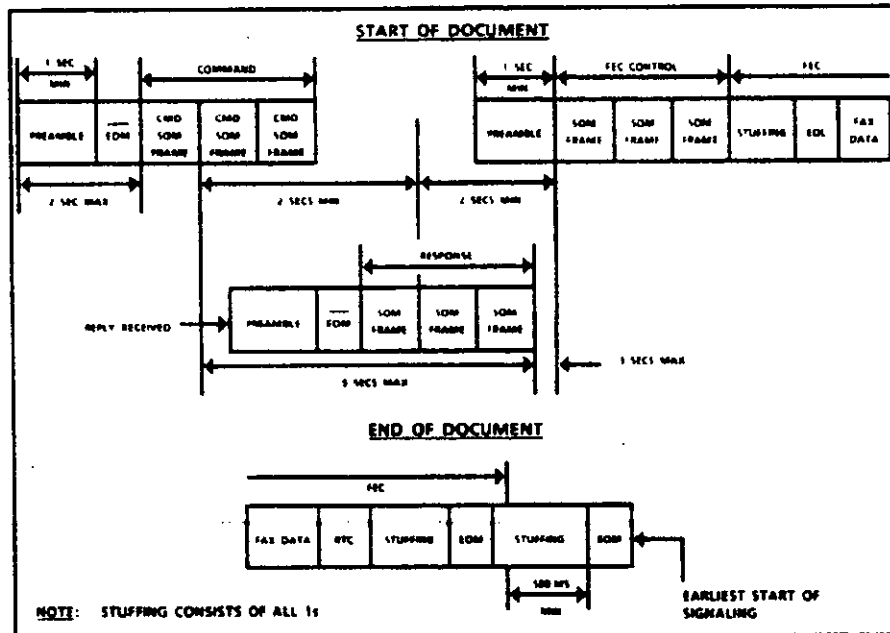

FIGURE 8. Signal timing, handshake mode, FEC used.

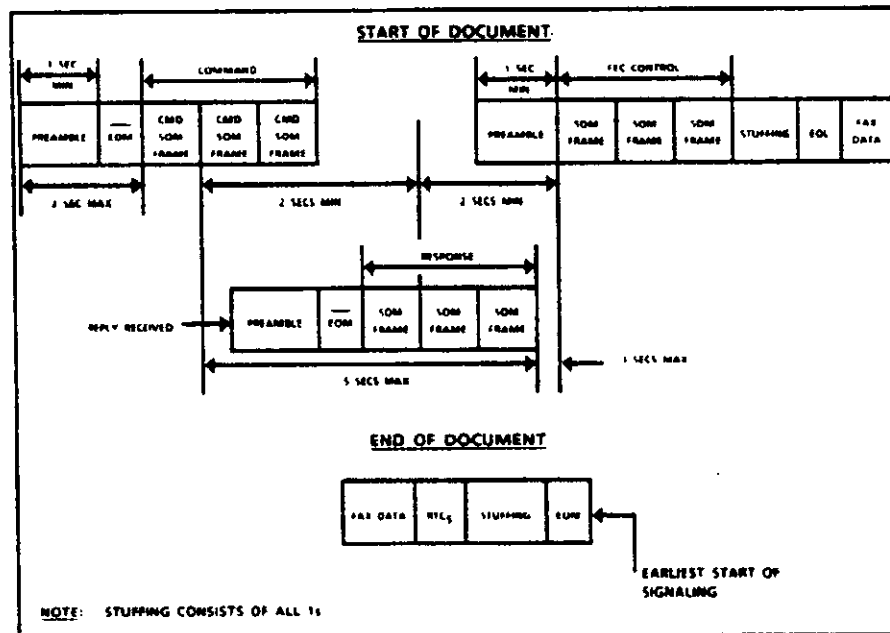

FIGURE 9. Signal timing, handshake mode, FEC not used.

MIL-STD-188-161A

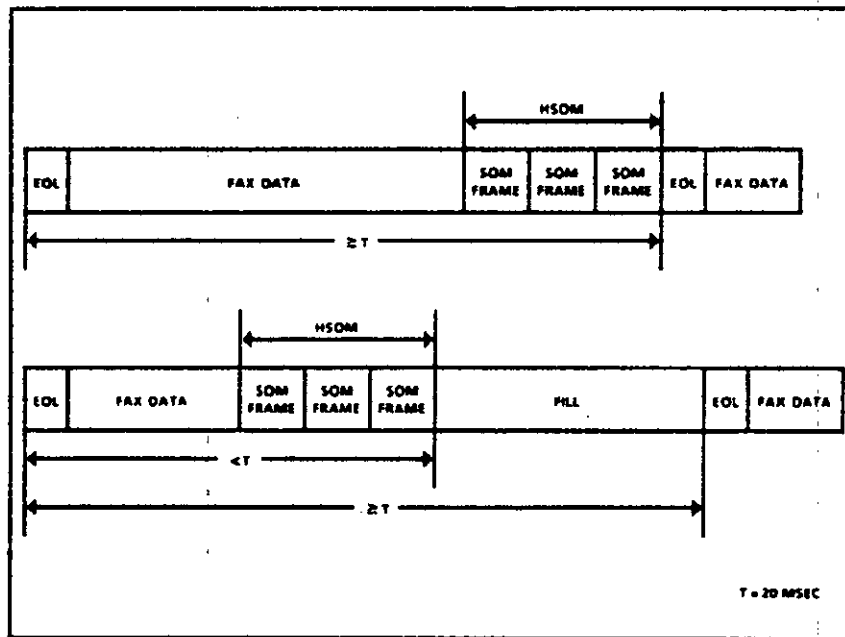

FIGURE 10. Transmission of the HSOM within a line of uncompressed data.

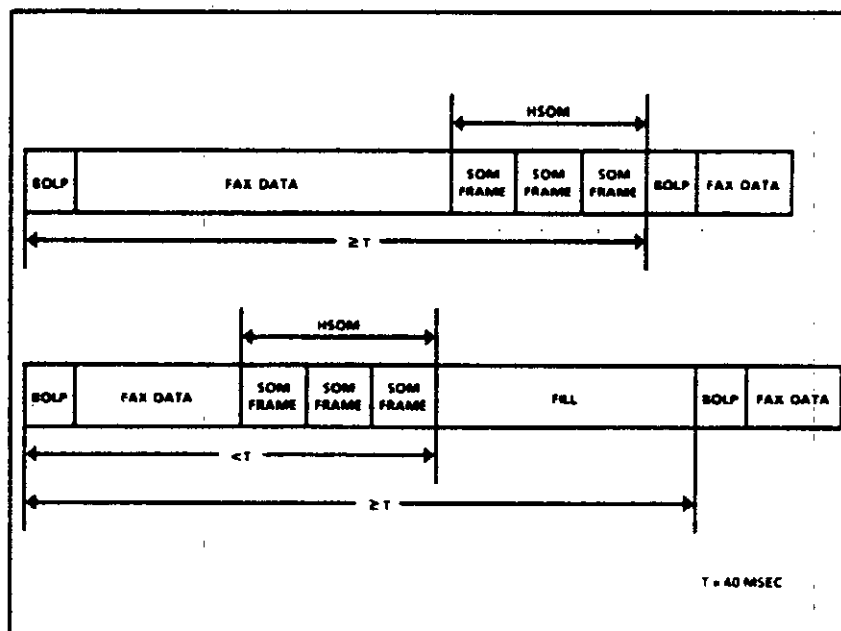

FIGURE 11. Transmission of the HSOM within a line of gray scale compressed data.

MIL-STD-188-161A

TABLE VIII. Normalized gray scale shades.

	STEP NUMBER	NORMALIZED DENSITY
PAPER WHITE	1	0.000
	2	0.067
	3	0.133
	4	0.200
	5	0.267
	6	0.333
	7	0.400
	8	0.467
	9	0.533
	10	0.600
	11	0.667
	12	0.733
	13	0.800
	14	0.867
	15	0.933
D MAXIMUM	16	1.000

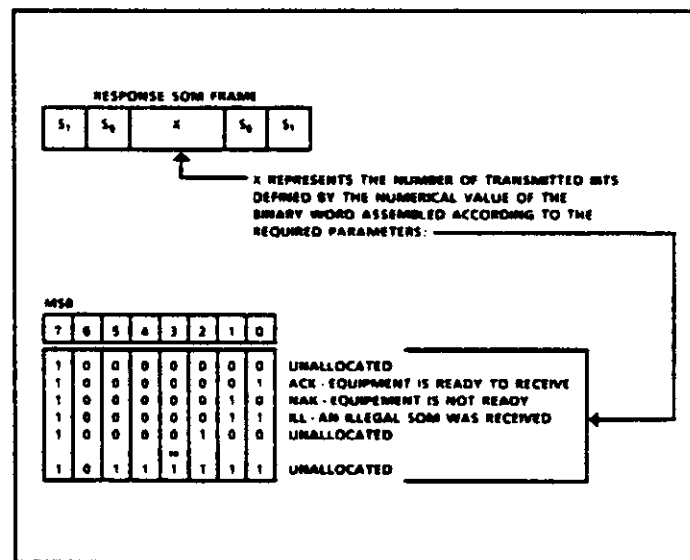

FIGURE 12. Value allocations for the response SOM frame.

MIL-STD-188-161A

those covered by this standard. Such equipment shall use unassigned X values for command SOM frames to convey this information.

5.3 Type II facsimile equipment.

5.3.1 Image parameters. The image parameters listed in subparagraph 5.2.1 apply to the Type II facsimile equipment. The minimum transmission time of any scanned line pair shall be 40 msec for all compressed gray scale modes; and 20 msec per line for all black and white, and uncompressed gray scale modes.

5.3.2 Black and white operation. All Type II facsimile equipment shall be capable of being operated as Type I black and white facsimile equipment. All of the requirements of paragraph 5.2 shall apply.

5.3.3 Gray scale operation. In addition to black and white operation, Type II facsimile equipments shall be capable of transmitting and receiving documents in 4, 8, and 16 shades of gray. The scanned dynamic range ($D_{max}/\text{Step 16}$ to Paper White/Step 1) shall be selected and the linear distribution of steps between these two shall be determined by the fractional values of table VIII. The recorded dynamic range ($D_{max}/\text{Step 16}$ to Paper White/Step 1) shall be determined by the reprographic process capability. The distribution of steps over the dynamic range is determined by the fractional values of table VIII. Recorded gray shade values shall be in accordance with table IX. (Note: The separation of this specification for the scanner and recorder allows a different dynamic range capability for each.)

5.3.3.1 Gray-coding the gray scale. Gray scale shall be processed by initial conversion of each picture element of the scanned signal to a four bit, Gray-code data unit (image data) representating one of the 16 shades of gray. A Gray-code in accordance with table IX shall be used so that a minimum number of transitions occur between adjacent gray levels. Gray-coding applies to all three image coding modes (uncompressed, compressed, and compressed with forward error correction).

5.3.3.2 Bit plane encoding the gray scale. After Gray-coding the data shall be processed as bit planes. The most significant bit (MSB) plane contains the MSB of each Gray-coded pel. Similarly, plane two shall contain the next most significant bit of each Gray-coded pel. (Note: Each plane, consisting of black and white pels, can be treated as a black and white image.) For 16 gray shades, the four bit planes shall be passed directly to the transmission process. For eight gray shades, bit plane four shall be discarded by discarding bit four and the remaining three bit codes representing eight gray shades shall be passed to the transmission process. Similarly, for four gray shades,

MIL-STD-188-161A

TABLE IX. Gray-codes for 4, 8, and 16 gray shades.

16 SHADES		8 SHADES		4 SHADES	
STEPS	GRAY CODE	STEPS	GRAY CODE	STEPS	GRAY CODE
1	0000	1	000	1	00
2	0001				
3	0011				
4	0010	4	001		
5	0110				
6	0111	6	011	6	01
7	0101				
8	0100	8	010		
9	1100				
10	1101	10	110		
11	1111				
12	1110	12	111	12	11
13	1010				
14	1011	14	101		
15	1001				
16	1000	16	100	16	10

MIL-STD-188-161A

plane three shall be discarded in addition to plane four. The remaining two bit codes represent four gray shades as shown in table IX.

5.3.3.3 Gray scale transmission. See Appendix C for general information (including block diagrams) relating to the modular make-up of the facsimile transmitter and receiver. Three output modes shall be available: (1) Uncompressed facsimile data with line synchronization codes added; (2) Compressed facsimile data using a two-dimensional algorithm; and (3) Compressed as in (2) with the addition of FEC using a BCH code and bit interleaving buffer. The scheme selected for a given transmission shall be signaled to the receiver. This signaling protocol shall be the same as covered in subparagraph 5.2.5.3.

5.3.3.3.1 Uncompressed. Uncompressed facsimile data shall be transmitted pel-by-pel per bit plane, with logic 1 representing black. Each scan line of the output data shall consist of a synchronization code followed by 1728 pels of the MSB plane followed by the 1728 pels of the next MSB planes in order until all bit planes of the line have been transmitted. (Note: Each bit plane is made up of black and white pels. The first bit plane contains the most significant bits of each gray encoded pel, the second bit plane contains the second MSB of each gray encoded pel, and the following bit planes are made up in a corresponding manner.) The synchronization codes shall consist of a sequence of two code words designated S_0 , and are identical to the codes utilized for Type I facsimile uncompressed transmission. See Appendix C for examples of the format used to transmit facsimile data with multiple gray shades.

5.3.3.3.2 Compressed. Compressed facsimile data shall be transmitted after compression by using a two-dimensional procedure.

5.3.3.3.2.1 Compressed data format. A line pair of compressed data (shown in figure 13) shall be composed of a series of variable length code words forming the bit planes (designated P1 through P4) representing the first 864 picture elements of each of the two adjacent horizontal scan lines of the original document (1728 total), followed by the second 864 elements of the two adjacent horizontal scan lines of the original document. Each half line pair of the output data shall consist of the bit planes in order (MSB plane first), each bit plane separated by a synchronization code word, EOL (000000000001). (Note: It is a unique code word that can never be found within a valid line pair of data. Therefore, resynchronization after an error burst is possible.)

5.3.3.3.2.2 Scan line pair. Each half line pair of output data shall be preceded by a three bit auto resolution code word (see subparagraph 5.3.3.3.3). The relative placement of the B0LP and B1LP code

MIL-STD-188-161A

words, auto resolution signaling bits, encoded data, EOL, RTC, and fill shall be as illustrated in figures 13 and 14. (Note: Transmission of 16 gray shades is shown. For the transmission of fewer gray shades, the appropriate bit planes and preceding EOL are not present.)

5.3.3.3.2.3 Wobbled scan lines. The two adjacent scan lines of data shall be "wobbled" on a bit plane by bit plane basis prior to variable-length encoding, by combining the spatially related data bits per bit plane in a wobble fashion as illustrated in figure 15. (Note: L₁₁, L₁₂, L₁₃, etc., represent the sequentially scanned bits derived from line N; and L₂₁, L₂₂, L₂₃, etc., represent the sequentially scanned bits derived from line N + 1. This produces a combined output of:

L₁₁, L₂₁, L₂₂, L₁₂, L₁₃, L₂₃, L₂₄, L₁₄, etc.

The purpose of this wobble pattern is to take advantage of both horizontal and vertical correlations of adjacent pels. This leads to a higher compression than can be achieved when one scan line (thus one dimensional coding) is processed at a time.)

5.3.3.3.2.4 Variable length code words. Each of the variable length code words shall represent a run-length of either all white or all black in a bit plane. White and black runs shall alternate. In order to ensure that the receiver maintains color (black and white) synchronization, each of the bit planes for each half of the data line pair shall begin with a white run-length code word. If an actual half data line of a bit plane begins with a black run, a white run-length of zero shall be sent first. Black or white run-lengths, up to a maximum length of one half scan line pair (1728 bits) shall be defined by the table III terminating codes and table IV make-up codes for each bit plane presentation of the image.

5.3.3.3.2.5 Run-length representation. Each run-length shall be represented by either one terminating code word, or one make-up code word followed by a terminating code word. (Note: Each bit plane represents a black and white image and four images comprise a total gray shade image.) Run-lengths in a range of 0 through 63 pels shall be encoded with their appropriate terminating code word. Run-lengths in the range of 64 through 1728 pels shall be encoded first by the make-up code word representing the run-length which is equal to or shorter than that required. This shall be followed by the terminating code word representing the difference between the required run-length and the run-length represented by the make-up code.

5.3.3.3.3 Auto resolution. Means shall be provided to implement a half (low) resolution function, on a selected bit plane basis to

MIL-STD-188-161A

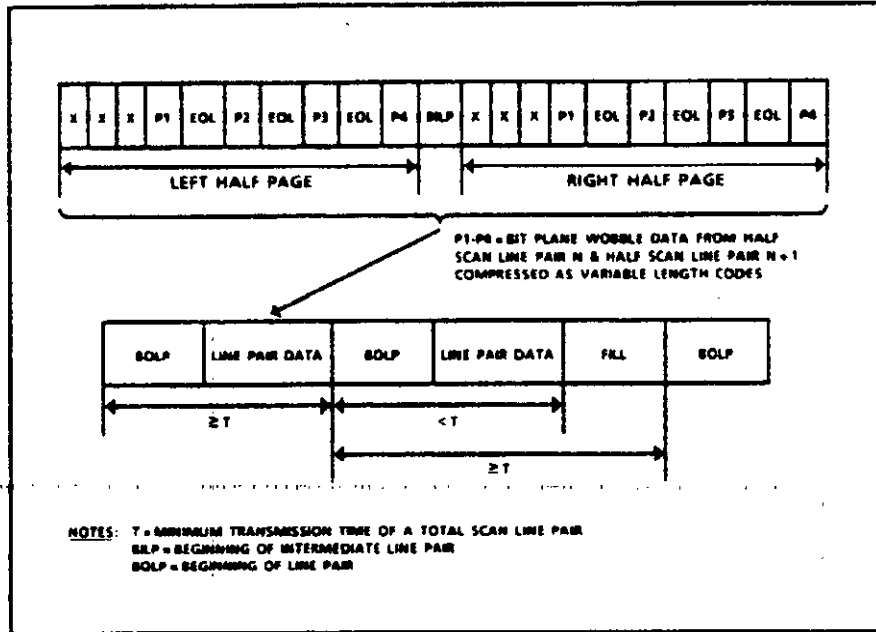

Figure 13. Encoded scan line pair of 16 gray shades starting at the beginning of a page.

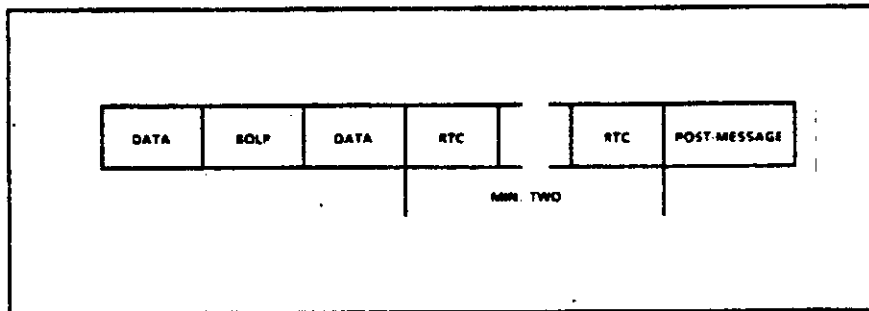

FIGURE 14. Example of an encoded scan line pair showing the last scan line pair of a page.

MIL-STD-188-161A

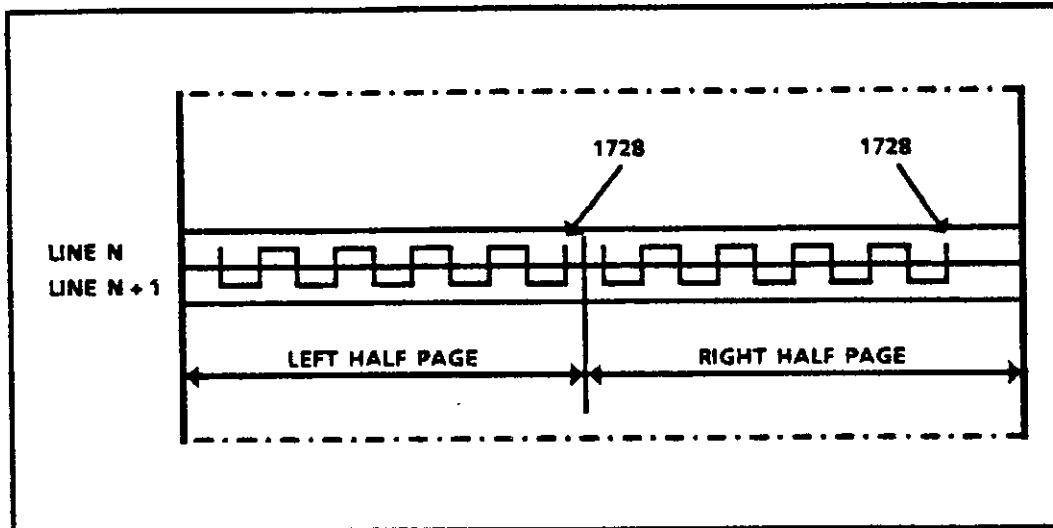

FIGURE 15. Bit plane wobble data format.

MIL-STD-188-161A

increase the achievable compression. (Note: This takes advantage of the fact that not all regions of a gray scale image contain high resolution information. Lower order bit planes have little effect on the perceived resolution and, as a consequence, may be transmitted at a lower resolution in regions of slow intensity variations.) Bit-plane activity shall be determined and low resolution operation shall be automatically applied on a half scan line pair (bit plane) basis when the number of transitions of a given bit plane is less than 60. (Note: The number of transitions is not an issue of interoperability and a threshold of sixty is a suggested implementation number.)

5.3.3.3.3.1 Auto resolution algorithm. The auto resolution algorithm is illustrated in table X. When half resolution processing is applied, a majority logic decision shall take place for each bit-plane group of four bits (L₁₁, L₁₂, L₁₃, etc.) being read in prior to run-length encoding. The process shall create a single bit which represents the average of the four bits.

5.3.3.3.3.2 Transmitter. The transmitter performs a majority logic decision such that if three or four bits are black, a black bit shall be substituted for the group of four. If zero, one, or two bits are black, a white bit shall be substituted for the group of four.

5.3.3.3.3.3 Receiver. The receiver shall expand each black data bit, or white data bit, received into four identical bits prior to processing the data stream for use by the recorder.

5.3.3.3.3.4 Signaling the auto resolution mode. Auto resolution processing shall be signaled to the receiving unit on a half scan line pair basis by preceding each half scan line pair, as shown in figure 13, with one of the three bit codes of table XI. If the first bit (as a consequence of majority logic decision) of a half scan line pair bit plane is black, a white run-length of zero shall be sent prior to the coded half line pair of bit plane data.

5.3.3.3.3.5 Beginning of line pair (BOLP). The BOLP code word shall precede each line pair of coded data (see figure 11). (Note: This is a unique code word than can never be found within a valid half line pair of coded data. Therefore, resynchronization after an error burst is possible (BOLP = 0000000000000010).)

5.3.3.3.3.6 Beginning of intermediate line pair (BILP). The BILP code word shall precede each (right half page) half line pair of data (see figure 13). (Note: This is a unique code word that can never be found within a valid half line pair of coded data. Therefore, resynchronization after an error burst is possible (BILP = 0000000000000011).)

MIL-STD-188-161A

TABLE X. Bit plane vs auto resolution function.

Bit Plane	Auto Resolution Algorithm		
	16 Gray Shades	8 Gray Shades	4 Gray Shades
1 (MSBP)	Not invoked	Not invoked	Not invoked
2	Automatic decision	Automatic decision	Automatic decision
3	Automatic decision	Automatic decision	Discard
4 (LSBP)	Low resolution Always invoked	Discard	Discard

TABLE XI. Auto resolution - signaling codes.

16 Gray Shades		8 Gray Shades		4 Gray Shades	
Code	Meaning	Code	Meaning	Code	Meaning
110	HHHL	110	HHH	---	---
100	HHLL	100	HHL	100	HH
000	HLLL	000	HLL	000	HL

MIL-STD-188-161A

5.3.3.3.3.7 Fill. A pause may be placed in the message flow by transmitting fill. Fill shall be inserted between a line pair of data and a BOLP but never within the bit planes. Fill shall be added to ensure that each line pair of data, fill, BOLP, and HSOM (when sent) exceeds the minimum transmission time of a total scan line pair. The minimum scan line transmission time shall be 40 msec for all compressed gray-scale modes and 20 msec for all black/white and uncompressed gray-scale modes (see figure 13). (Note: The maximum transmission time for a single line pair is bounded by the limits set for the loss of synchronization check. See subparagraph 5.3.4.)

5.3.3.3.3.8 Return to control (RTC). The end of a document transmission shall be indicated by sending at least two RTC code words. Each RTC shall consist of six consecutive EOLs. Following the RTC signals, the transmitter shall send the post-message commands. (RTC = EOL code word 00000000001 repeated six times.)

5.3.3.3.4 Compressed with forward error correction (FEC). Since each bit plane of a gray-scale image is in itself a black and white image, the requirements for channel coder and decoder, bit interleaving buffer, and synchronization techniques described in subparagraph 5.2.3.3 shall apply.

5.3.4 Loss of facsimile synchronization. The Type II facsimile shall be capable of detecting loss of synchronization. The technique used shall be the same as for Type I facsimile (see paragraph 5.2.4).

5.3.5 Signaling protocols. The protocol signal structure shall be identical to the protocol signal structure used for Type I facsimile equipment (see paragraph 5.2.5).

5.3.5.1 Synchronization code words. The synchronization code words to be used for Type II facsimile equipment shall be identical to the words used for Type I facsimile equipment (see subparagraph 5.2.5.1.1).

5.3.5.1.1 Start of message (SOM). Each SOM frame shall consist of two pairs of synchronization code words $S_1 S_0$ and $S_0 S_1$, the pairs separated by several (X) clock periods. The mode shall be indicated by the number of clock periods (X) between the two pairs of synchronization code words. The 15 values of X that shall be used are shown in figure 4. (Note: The polarity of the bits in the X interval is irrelevant as it is the count of clock intervals between pairs of synchronization code words which designates the mode.) The data bits transmitted in this interval shall be all 1s. The SOM frame shall be transmitted three times, but detecting any one frame at the receiver shall be sufficient. Uses of these signals are covered in subparagraph 5.2.5.2.

MIL-STD-188-161A

5.3.5.1.2 End of message (EOM). EOM shall consist of at least 16 S₁ code words transmitted in sequence. When four consecutive S₁ code words have been detected at the receiver, EOM shall be declared. This procedure shall be identical to Type I facsimile equipment as covered in subparagraph 5.2.5.1.3.

5.3.5.2 Signaling sequence and timing. The signaling sequences and timing procedures for compressed mode, with and without FEC, and the uncompressed mode shall be identical to signaling sequences and timing procedures described in subparagraph 5.2.5.2.

5.3.5.3 Handshake mode protocol. The handshake mode protocol shall be identical to the protocol presented in subparagraph 5.2.5.3.

5.3.5.4 Extended protocols. See subparagraph 5.2.5.4 for methods that may be used when an exchange of status signal not covered in this standard needs to be implemented for Type II facsimile equipment.

MIL-STD-188-161A

6. KEY WORDS

6.1 Key word list. The following key words and phrases apply to MIL-STD-188-161A.

- basic mode
- bit plane
- code word
- compressed mode
- digital facsimile
- facsimile
- facsimile synchronization
- gray code
- gray scale
- group three facsimile
- handshake mode
- image coding
- military standard
- scan line
- signaling protocols
- STANAG 5000
- type I facsimile
- type II facsimile
- uncompressed mode
- wobbled scan

MIL-STD-188-161A

Custodians:

Army - CR
Navy - EC
Air Force - 90
DCA - DC

Preparing Activity
JTC3A - JT

(Project SLHC-1611)

Review activities:

Army - SC
Navy - OM, NOSC, MC
Air Force - XOKC
NSA - NS

User Activities:

Navy - MCLB
Air Force - 11

Other Interest:

Applicable International Organizations
North Atlantic Treaty Organization

MIL-STD-188-161A

APPENDIX A

**MEMORANDUM FROM UNDER SECRETARY
OF DEFENSE, RESEARCH AND ENGINEERING,
16 AUGUST 1983, SUBJECT:
MANDATORY USE OF MILITARY TELECOMMUNICATIONS
STANDARDS IN THE MIL-STD-188 SERIES**

This appendix contains information related to MIL-STD-188-161A. Appendix A is a mandatory part of the standard.



RESEARCH AND
ENGINEERING

THE UNDER SECRETARY OF DEFENSE
WASHINGTON, D.C. 20301

16 AUG 1983

MEMORANDUM FOR ASSISTANT SECRETARY OF THE ARMY (INSTALLATIONS, LOGISTICS &
FINANCIAL MANAGEMENT)
ASSISTANT SECRETARY OF THE NAVY (SHIPBUILDING & LOGISTICS)
ASSISTANT SECRETARY OF THE AIR FORCE (RESEARCH DEVELOPMENT
& LOGISTICS)
COMMANDANT OF THE MARINE CORPS
DIRECTOR, DEFENSE COMMUNICATIONS AGENCY
DIRECTOR, NATIONAL SECURITY AGENCY

SUBJECT: Mandatory Use of Military Telecommunications Standards in the
MIL-STD-188 Series

On May 10, 1977, Dr. Gerald Dinneen, then Assistant Secretary of Defense (C3I), issued the following policy statement regarding the mandatory nature of the MIL-STD-188 series telecommunications standards:

"...standards as a general rule are now cited as 'approved for use' rather than 'mandatory for use' in the Department of Defense.

This deference to the judgment of the designing and procuring agencies is clearly appropriate to standards dealing with process, component ruggedness and reliability, paint finishes, and the like. It is clearly not appropriate to standards such as those in the MIL-STD-188 series which address telecommunication design parameters. These influence the functional integrity of telecommunication systems and their ability to efficiently interoperate with other functionally similar Government and commercial systems. Therefore, relevant military standards in the 188 series will continue to be mandatory for use within the Department of Defense.

To minimize the probability of misapplication of these standards, it is incumbent upon the developers of the MIL-STD-188 series to insure that each standard is not only essential but of uniformly high quality, clear and concise as to application, and wherever possible compatible with existing or proposed national, international and Federal telecommunication standards. It is also incumbent upon the users of these standards to cite in their procurement specifications only those standards which are clearly necessary to the proper functioning of the device or systems over its projected lifetime."

This statement has been reviewed by this office and continues to be the policy of the Department of Defense.

A handwritten signature in dark ink, appearing to read "R. D. DeLoach".

MIL-STD-188-161A

APPENDIX B
ABBREVIATIONS AND ACRONYMS

This appendix contains general information in support of MIL-STD-188-161A. Appendix B is not a mandatory part of this standard.

MIL-STD-188-161A**Abbreviations and Acronyms**

BCH	-	Bose Chandhuri Hocquenghem code, a cyclic code
BER	-	Bit Error Rate
BILP	-	Beginning of Intermediate Line Pair
BOLP	-	Beginning of Line Pair
CCITT	-	International Telegraph and Telephone Consultative Committee
COMSEC	-	Communications Security
DCA	-	Defense Communications Agency
DCE	-	Data Circuit-terminating Equipment
DCS	-	Defense Communications System
DOD	-	Department of Defense
DODD	-	Department of Defense Directive
DODISS	-	Department of Defense Index of Specifications and Standards
DTE	-	Data Terminal Equipment
EMSEC	-	Emanations Security
EIA	-	Electronic Industries Association
EOL	-	End of Line
EOM	-	End of Message
FAX	-	Facsimile
FEC	-	Forward Error Correction
HSOM	-	Handshake Start of Message
JCS	-	Joint Chiefs of Staff
LSB	-	Least Significant Bit

MIL-STD-188-161A

MSB	-	Most Significant Bit
MODEM	-	Modulator-Demodulator
NACSIM	-	National COMSEC/EMSEC Information Memorandum
NATO	-	North Atlantic Treaty Organization
NMCS	-	National Military Command System
PN	-	Pseudorandom Noise
RTC	-	Return to Control
SOM	-	Start of Message
STANAG	-	Standardization Agreement (NATO)

MIL-STD-188-161A

This page intentionally left blank.

MIL-STD-188-161A

APPENDIX C

**SUGGESTED IMPLEMENTATIONS FOR
DIGITAL FACSIMILE**

This appendix contains general information
in support of MIL-STD-188-161A. Appendix C is
not a mandatory part of this standard

MIL-STD-188-161A

10 GENERAL

10.1 Scope. Tutorial information related to digital facsimile.

20 REFERENCE DOCUMENTS

STANAG 5000, Interoperability of Tactical Digital Facsimile Equipment.

30 DEFINITIONS

Not applicable.

40 GENERAL REQUIREMENTS

40.1 The facsimile shall be implemented with the latest technology that is available within reasonable cost and time constraints.

50 SPECIFIC REQUIREMENTS

50.1 Transmitter. The general make up of the facsimile transmitter is shown in block diagram form in figure 1-C. Illustrated are the three outputs: lead A for the uncompressed mode, lead B for the compressed mode, and lead C for the compressed with forward error correction mode. These outputs are in agreement with the NATO needs as covered in STANAG 5000.

50.2 Receiver. The general make up of the facsimile receiver is illustrated in block diagram form in figure 2-C. The uncompressed mode, compressed mode, and compressed with forward error correction mode are shown. The mode inputs are depicted by points A, B and C respectively.

50.3 Encoder. Figure 3-C illustrates an implementation of the BCH-encoder using a feedback-shift-register. The length of the feedback-shift-register is 12 bits according to the generator polynomial shown in the figure. During one cycle of 63 clocks, one block of data is sent at the output of the BCH-encoder. At the beginning of the cycle the contents of the feedback-shift-register (r_0, \dots, r_{11}) are equal to 0. Initially 51 information bits are transmitted from the data input to the output. At the same time the information bits are running into the feedback loop of the shift register ($C_0 = 1$). After 51 clocks the contents of the feedback-shift-register (r_0, \dots, r_{11}) are transmitted with 12 clocks $C_0 = 0$. These 12 bits are the check bits for the block of 63 data bits. After every cycle of 63 clocks, the contents of the feedback-shift-register should be zero ($r_0, \dots, r_{11} = 0$). The next 51 information bits can then be encoded.

MIL-STD-188-161A

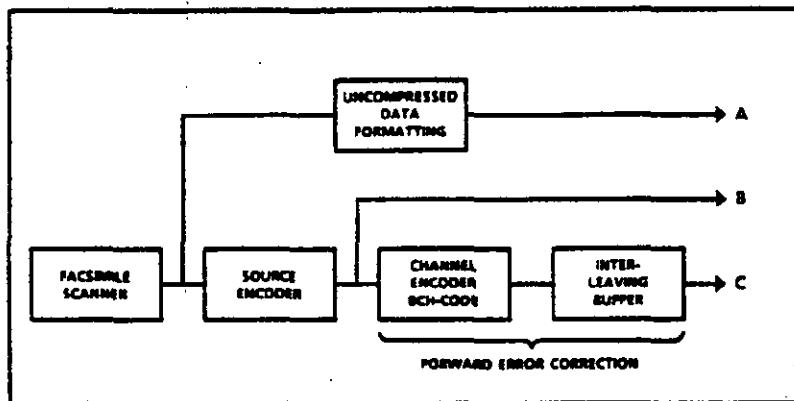

FIGURE 1-C. Block diagram of the encoder.

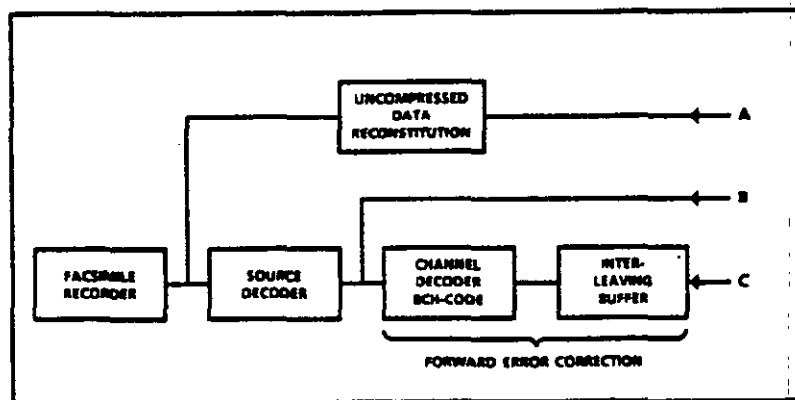
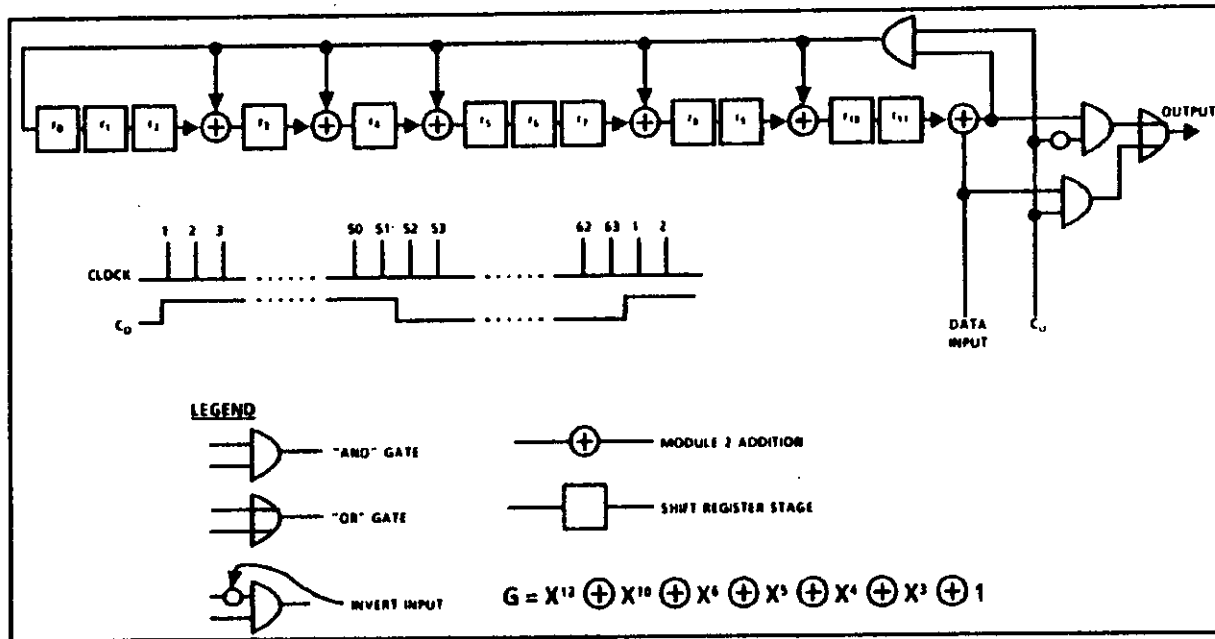

FIGURE 2-C. Block diagram of the decoder.



MIL-STD-188-161A

FIGURE 3-C. Block diagram of the BCH encoder.

MIL-STD-188-161A

50.4 Decoder. Figure 4-C illustrates an implementation of the BCH-decoder. The BCH-decoder uses the same feedback-shift-register as the BCH-encoder, plus a 63 bit buffer memory (shift register) and a network. One complete decoding cycle consists of 126 clocks (2×63). At the beginning of every cycle the contents of the feedback-shift-register (r_0, \dots, r_{11}) must be equal to 0. The clock appears at the same time to the feedback-shift-register and the 63 bit buffer memory. During the first 63 clocks, the block of 63 data bits are written into the 63 bit buffer memory and at the same time run into the feedback loop of the shift-register ($C_1 = 0$). During the next 63 clocks ($C_1 = 1$) the transmission bit errors are corrected, if there are any. The contents of the feedback-shift-register (r_0, \dots, r_{11}) are analyzed after every clock by the error detection network. If the network detects any one of the 12 bit patterns (syndromes) listed in table V (see subparagraph 5.2.3.3) as the contents of the feedback-shift-register, when the position of a transmission bit error is found to be at the output of the 63 bit buffer memory. At that time the output of the network will correct the transmission bit error by sending a 1 to the modulo 2-adder at the output of the 63 bit buffer memory. Note that only the first 51 bits are information bits. After every cycle of 126 clocks the feedback-shift-register must be reset to zero ($r_0, \dots, r_{11} = 0$) and the next block of 63 data bits can be encoded.

50.4 Scan line data format. The scan line data format (code words plus data) for 16 gray shades, in the uncompressed mode is:

	Plane 1	Plane 2	Plane 3	Plane 4
$S_0 \ S_0$	1728 bits	1728 bits	1728 bits	1728 bits

The scan line data format for 8 gray shades (uncompressed) is:

	Plane 1	Plane 2	Plane 3
$S_0 \ S_0$	1728 bits	1728 bits	1728 bits

The scan line data format for 4 gray shades (uncompressed) is:

	Plane 1	Plane 2
$S_0 \ S_0$	1728 bits	1728 bits

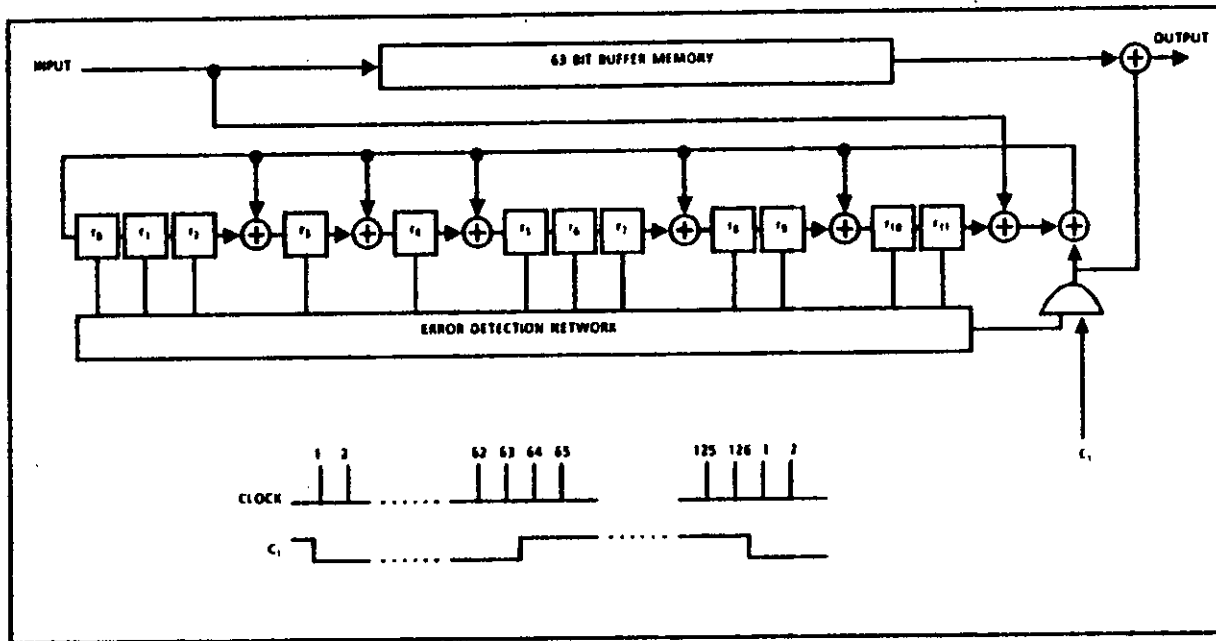

MIL-STD-188-161A

FIGURE 4-C. Block diagram of a BCH decoder.

MIL-STD-188-161A

The general format for scan line data is a pair of S_0 code words followed by the number of bit planes needed to convey each gray shade being used. Table I-C presents examples of the information makeup of uncompressed, medium resolution scan line data?

TABLE I-C. Examples of the information makeup for uncompressed, medium resolution scan line data.

Gray Shades	Bit Planes	Information Bits
16	4	4 x 1728 = 6912
8	3	3 x 1728 = 5184
4	2	2 x 1728 = 3456
Black/White	1	1 x 1728 = 1728

NOTE: For uncompressed facsimile data, the number of bits in a bit plane corresponds to the number of pels in the scan line.

MIL-STD-188-161A

This page intentionally left blank.

STANDARDIZATION DOCUMENT IMPROVEMENT PROPOSAL

(See Instructions - Reverse Side)

1. DOCUMENT NUMBER MIL-STD-188-161A	2. DOCUMENT TITLE Interop and Performance Standards for Digital Facsimile Equip
---	---

3. NAME OF SUBMITTING ORGANIZATION

4. TYPE OF ORGANIZATION (Select one)

VENDOR

USER

MANUFACTURER

OTHER (Specify) _____

5. ADDRESS (Street, City, State, ZIP Code)

6. PROBLEM AREAS

a. Paragraph Number and Wording

b. Recommended Wording

c. Reason/Reasons for Recommendation

7. REMARKS

7a. NAME OF SUBMITTER (Last First MI) - Optional

7b. WORK TELEPHONE NUMBER (Include Area Code) - Optional

8. MAILING ADDRESS (Street, City, State, ZIP Code) - Optional

9. DATE OF SUBMISSION (YYMMDD)