

NOTE: The cover page of this standard has been changed for administrative reasons. There are no other changes to this document

NOT  
MEASUREMENT  
SENSITIVE

MIL-STD-188-141A  
15 SEPTEMBER 1988  
SUPERSEDING  
MIL-STD-188-141  
28 MARCH 1966

# DEPARTMENT OF DEFENSE INTERFACE STANDARD

## INTEROPERABILITY AND PERFORMANCE STANDARDS FOR MEDIUM AND HIGH FREQUENCY RADIO EQUIPMENT



AMSC N/A

AREA SLHC

DISTRIBUTION STATEMENT A. Approved for public release; distribution is unlimited

## MIL-STD-188-141A

### FOREWORD

1. This military standard is approved and is mandatory for use by all Departments and Agencies of the Department of Defense in accordance with DoD Directive 4640.11, dated 21 December 1987.

2. Beneficial comments (recommendations, additions, deletions) and any pertinent data which may be of use in improving this document should be addressed to: Commander, U.S. Army Information Systems Engineering Command, ATTN: ASB-SET-T, Fort Huachuca, AZ 85613-5300, by using the self-addressed Standardization Document Improvement Proposal (DD Form 1426) appearing at the end of this document, or by letter.

3. Originally, Military Standard 188 (MIL-STD-188) covered technical standards for tactical and long-haul communications, but later evolved through revisions (MIL-STD-188A, MIL-STD-188B) into a document applicable to tactical communications only (MIL-STD-188C).

4. The Defense Communications Agency (DCA) published DCA Circulars (DCACs) promulgating standards and engineering criteria applicable to the long-haul Defense Communications System (DCS) and to the technical support of the National Military Command System (NMCS).

5. As a result of a Joint Chiefs of Staff (JCS) action, standards for all military communications are now being published in a MIL-STD-188 series of documents. The MIL-STD-188 series is subdivided into a MIL-STD-188-100 series covering common standards for tactical and long-haul communications, a MIL-STD-188-200 series covering standards for tactical communications only, and a MIL-STD-188-300 series covering standards for long-haul communications only. Emphasis is being placed on developing common standards for tactical and long-haul communications published in the MIL-STD-188-100 series.

6. This document contains technical standards and design objectives for medium and high frequency radio equipment. Automatic and adaptive features have been considered throughout and included when considered applicable across the full range of possible HF equipment employment and operational configurations.

## MIL-STD-188-141A

## CONTENTS

<u>PARAGRAPH</u>		<u>PAGE</u>
1.	SCOPE . . . . .	1
1.1	Scope . . . . .	1
1.2	Applicability . . . . .	1
1.3	Application guidance. . . . .	1
2.	APPLICABLE DOCUMENTS. . . . .	3
2.1	Government documents. . . . .	3
2.1.1	Specifications, standards, and handbooks. . . . .	3
2.1.2	Other Government documents, drawings, and publications. . . . .	3
2.2	Non-Government publications . . . . .	4
2.3	Order of precedence . . . . .	5
3.	DEFINITIONS . . . . .	7
3.1	Terms . . . . .	7
3.2	Abbreviations and acronyms. . . . .	9
4.	GENERAL REQUIREMENTS. . . . .	13
4.1	General . . . . .	13
4.2	Equipment operation modes . . . . .	13
4.2.1	Baseline mode . . . . .	13
4.2.1.1	Single-channel. . . . .	13
4.2.1.2	Multichannel. . . . .	14
4.2.2	Automatic link establishment (ALE) mode . . . . .	14
4.2.3	Anti-jam (AJ) mode. . . . .	14
4.3	Interface parameters. . . . .	14
4.3.1	Electrical characteristics of digital interfaces. . . . .	14
4.3.2	Electrical characteristics of analog interfaces . . . . .	14
4.3.3	Modulation and data signaling rates . . . . .	14
4.4	North Atlantic Treaty Organization (NATO) and Quadripartite interoperability requirements . . . . .	14
4.4.1	Single-channel communications systems . . . . .	14
4.4.2	Maritime air communications systems . . . . .	16
4.4.3	High performance HF data modems . . . . .	16
4.4.4	Quadripartite Standardization Agreements (QSTAGs) . . . . .	16
4.5	Adaptive communications . . . . .	16
5.	DETAILED REQUIREMENTS . . . . .	17
5.1	General . . . . .	17
5.1.1	Introduction. . . . .	17
5.1.2	Signal and noise relationships. . . . .	17
5.2	Common equipment characteristics. . . . .	17
5.2.1	Displayed frequency . . . . .	17
5.2.2	Frequency coverage. . . . .	17
5.2.3	Frequency accuracy. . . . .	17
5.2.4	Phase stability . . . . .	17
5.2.5	Phase noise . . . . .	17

## MIL-STD-188-141A

## CONTENTS

<u>PARAGRAPH</u>		<u>PAGE</u>
5.2.6	Bandwidths. . . . .	20
5.2.7	Overall channel responses . . . . .	20
5.2.7.1	Single-channel or dual-channel operation. . . . .	20
5.2.7.2	Four-channel operation. . . . .	23
5.2.8	Absolute delay. . . . .	23
5.2.9	Lincompex . . . . .	23
5.3	Transmitter characteristics . . . . .	23
5.3.1	Noise and distortion. . . . .	23
5.3.1.1	In-band noise . . . . .	23
5.3.1.2	Intermodulation distortion (IMD). . . . .	25
5.3.2	Spectral purity . . . . .	25
5.3.2.1	Broadband emissions . . . . .	25
5.3.2.2	Discrete frequency spurious emissions . . . . .	27
5.3.3	Carrier suppression . . . . .	27
5.3.4	Automatic level control (ALC) . . . . .	27
5.3.5	Attack and release time delays. . . . .	27
5.3.5.1	Attack-time delay . . . . .	27
5.3.5.2	Release-time delay. . . . .	27
5.3.6	Signal input interface characteristics. . . . .	27
5.3.6.1	Input signal power. . . . .	27
5.3.6.2	Input audio signal interface. . . . .	27
5.3.6.2.1	Unbalanced interface. . . . .	27
5.3.6.2.2	Balanced interface. . . . .	27
5.3.7	Transmitter output load impedance . . . . .	29
5.4	Receiver characteristics. . . . .	29
5.4.1	Receiver rf characteristics . . . . .	29
5.4.1.1	Image rejection . . . . .	29
5.4.1.2	Intermediate-frequency (IF) rejection . . . . .	29
5.4.1.3	Adjacent-channel rejection. . . . .	29
5.4.1.4	Other single-frequency external spurious responses. . . . .	29
5.4.1.5	Receiver protection . . . . .	29
5.4.1.6	Desensitization dynamic range . . . . .	31
5.4.1.7	Receiver sensitivity. . . . .	31
5.4.1.8	Receiver out-of-band IMD. . . . .	31
5.4.1.9	Third-order intercept point . . . . .	31
5.4.2	Receiver distortion and internally generated spurious outputs. . . . .	31
5.4.2.1	Overall IMD (in-channel). . . . .	31
5.4.2.2	Adjacent-channel IMD. . . . .	32
5.4.2.3	Audio frequency total harmonic distortion . . . . .	32
5.4.2.4	Internally generated spurious outputs . . . . .	32
5.4.3	Automatic gain control (AGC) characteristic . . . . .	32
5.4.3.1	AGC attack time (nondata modes) . . . . .	32
5.4.3.2	AGC release time (nondata modes). . . . .	32
5.4.3.3	AGC requirements for data service . . . . .	32
5.4.4	Receiver linearity. . . . .	32
5.4.5	Interface characteristics . . . . .	32



## MIL-STD-188-141A

## CONTENTS

<u>PARAGRAPH</u>		<u>PAGE</u>
5.4.5.1	Input impedance . . . . .	32
5.4.5.2	Output impedance and power. . . . .	33
5.5	Automatic link establishment (ALE). . . . .	33
6.	NOTES . . . . .	35
6.1	Intended use. . . . .	35
6.2	Issue of DODISS . . . . .	35
6.3	Subject term (key word) listing . . . . .	35
6.4	International standardization agreements. . . . .	35
6.5	Changes from previous issue . . . . .	35
 <u>FIGURES</u>		
1	Radio subsystem interface points. . . . .	15
2	Phase noise limit mask for fixed site and transportable long-haul radio transmitters with temperature-controlled frequency-determining elements. . . . .	18
3	Phase noise limit mask for tactical radio transmitters without temperature-controlled frequency-determining elements. . . . .	19
4	Overall channel response for single-channel or dual-channel equipment. . . . .	21
5	Overall channel characteristics (four-channel equipment). . . . .	22
6	Lincomplex calibration sequence. . . . .	24
7	Out-of-band power spectral density for HF transmitters. . . . .	26
8	Discrete spurious emissions limit for HF transmitters . . . . .	28
9	Output power vs. VSWR for transmitters with broadband output impedance networks . . . . .	30
 <u>TABLES</u>		
I	Bandwidths. . . . .	20
II	Out-of-band power spectral density limits for radio transmitters. . . . .	25
 <u>APPENDIXES</u>		
APPENDIX A	AUTOMATIC LINK ESTABLISHMENT SYSTEM . . . . .	37
10.	GENERAL . . . . .	37
10.1	Scope . . . . .	37
10.2	Applicability . . . . .	37

## MIL-STD-188-141A

## CONTENTS

<u>APPENDIXES</u>		<u>PAGE</u>
APPENDIX A		
20.	APPLICABLE DOCUMENTS. . . . .	37
20.1	Government documents. . . . .	37
20.2	Non-Government publications . . . . .	37
30.	DEFINITIONS . . . . .	38
30.1	Standard definitions and acronyms . . . . .	38
30.2	Definitions of timing symbols . . . . .	38
40.	GENERAL REQUIREMENTS. . . . .	38
40.1	System test performance . . . . .	38
40.2	Channel memory. . . . .	40
40.3	Scanning. . . . .	42
40.4	Self address memory . . . . .	42
40.5	Other address memory. . . . .	44
40.6	Connectivity and LQA memory . . . . .	44
50.	WAVEFORM. . . . .	47
50.1	Introduction. . . . .	47
50.2	Tones . . . . .	47
50.3	Timing. . . . .	47
50.4	Accuracy. . . . .	47
60.	SIGNAL STRUCTURE. . . . .	49
60.1	Introduction. . . . .	49
60.2	Word format . . . . .	49
60.2.1	Structure . . . . .	49
60.2.2	Word types. . . . .	49
60.2.3	Preambles . . . . .	49
60.2.3.1	THRU. . . . .	49
60.2.3.2	TO. . . . .	49
60.2.3.3	COMMAND . . . . .	52
60.2.3.4	FROM. . . . .	52
60.2.3.5	THIS IS . . . . .	52
60.2.3.6	THIS WAS. . . . .	53
60.2.3.7	DATA. . . . .	53
60.2.3.8	REPEAT. . . . .	53
60.2.3.9	Valid sequences . . . . .	53
60.2.4	Characters. . . . .	53
60.2.4.1	General . . . . .	53
60.2.4.2	Basic 38 ASCII subset . . . . .	58
60.2.4.3	Expanded 64 ASCII subset. . . . .	58
60.2.4.4	Full 128 ASCII set and binary data. . . . .	61
60.3	Coding. . . . .	61
60.3.1	Introduction. . . . .	61
60.3.2	Forward error correction (FEC). . . . .	61

## MIL-STD-188-141A

## CONTENTS

<u>APPENDIXES</u>	<u>PAGE</u>
APPENDIX A	
60.3.2.1	Encoding. . . . . 61
60.3.2.2	Decoding. . . . . 61
60.3.3	Interleaving and deinterleaving . . . . . 67
60.3.4	Redundant words . . . . . 67
60.4	Word framing and synchronization. . . . . 67
60.4.1	General . . . . . 67
60.4.2	Framing . . . . . 67
60.4.2.1	Calling cycle . . . . . 71
60.4.2.2	Message . . . . . 71
60.4.2.3	Conclusion. . . . . 76
60.4.2.4	Basic frame structure examples. . . . . 76
60.4.3	Synchronization . . . . . 76
60.4.3.1	Transmit modulator. . . . . 76
60.4.3.2	Receive demodulator . . . . . 76
60.4.3.3	Synchronization criteria. . . . . 76
60.5	Addressing. . . . . 80
60.5.1	Introduction. . . . . 80
60.5.2	Individual station. . . . . 81
60.5.2.1	Basic . . . . . 81
60.5.2.2	Extended. . . . . 82
60.5.3	Multiple stations . . . . . 82
60.5.3.1	Net . . . . . 82
60.5.3.2	Group . . . . . 84
60.5.4	Special modes "@" and "?" . . . . . 84
60.5.4.1	General . . . . . 84
60.5.4.2	Stuffing. . . . . 84
60.5.4.3	Allcalls. . . . . 86
60.5.4.4	Anycalls. . . . . 87
60.5.4.5	Wildcards . . . . . 89
60.5.4.6	Self address. . . . . 89
60.5.4.7	Null address. . . . . 89
60.6	Link quality analysis (LQA) . . . . . 91
60.6.1	General . . . . . 91
60.6.2	Basic bit error ratio (BER) . . . . . 91
60.6.3	Signal plus noise plus distortion to noise plus distortion ratio (SINAD). . . . . 92
60.6.4	Multipath (MP). . . . . 92
60.7	Channel selection . . . . . 92
60.7.1	General . . . . . 92
60.7.2	Single-station channel selection. . . . . 92
60.7.3	Multiple-station channel selection. . . . . 95
70.	PROTOCOLS . . . . . 97
70.1	Introduction. . . . . 97
70.2	Manual operation. . . . . 97

## MIL-STD-188-141A

## CONTENTS

<u>APPENDIXES</u>	<u>PAGE</u>
<u>APPENDIX A</u>	
70.2.1	Operator control. . . . . 97
70.2.2	Push-to-talk operation. . . . . 97
70.3	ALE operational rules . . . . . 97
70.4	Individual calling. . . . . 97
70.4.1	Introduction. . . . . 97
70.4.2	Single channel. . . . . 100
70.4.3	Multiple channels . . . . . 103
70.4.4	Timing. . . . . 107
70.5	Sounding. . . . . 111
70.5.1	Introduction. . . . . 111
70.5.2	Single channel. . . . . 112
70.5.3	Multiple channels . . . . . 112
70.5.4	Optional handshake. . . . . 117
70.6	Multiple stations operations. . . . . 117
70.6.1	General . . . . . 117
70.6.2	Star net. . . . . 119
70.6.3	Star group. . . . . 124
80.	ORDERWIRE MESSAGES. . . . . 129
80.1	Introduction. . . . . 129
80.2	Link quality analysis (LQA) . . . . . 129
80.2.1	Bit error ratio (BER) . . . . . 129
80.2.2	Signal plus noise plus distortion to noise plus distortion ratio (SINAD). . . . . 129
80.2.3	Multipath (MP). . . . . 129
80.3	Automatic message display (AMD) mode. . . . . 132
80.4	Data text message (DTM) mode. . . . . 133
80.5	Data block message (DBM) mode . . . . . 144
80.6	Cyclic redundancy check (CRC) . . . . . 156
80.7	Tune and wait . . . . . 158
80.8	Time-related special functions of all <u>COMMANDS</u> . . . . . 158
80.9	User unique functions (UUF) . . . . . 162
90.	LINK PROTECTION . . . . . 165
90.1	General . . . . . 165
90.2	Description . . . . . 165
90.3	Synchronization . . . . . 165
90.4	Location. . . . . 165
90.5	Implementation. . . . . 165
<u>FIGURES</u>	
A-1	System performance measurements test setup. . . . . 39
A-2	Connectivity and LQA memory example . . . . . 46
A-3	ALE symbol library. . . . . 48

## MIL-STD-188-141A

## CONTENTS

<u>FIGURES</u>		<u>PAGE</u>
A-4	ALE basic word structure. . . . .	50
A-5	Valid word sequences. . . . .	54
A-6	Basic 38 ASCII subset. . . . .	59
A-7	Expanded 64 ASCII subset. . . . .	60
A-8	Full 128 ASCII set. . . . .	62
A-9	Generator matrix for (24, 12) extended Golay code . . . .	63
A-10	Golay word encoding example . . . . .	64
A-11	Golay FEC coding examples . . . . .	65
A-12	Parity-check matrix for (24, 12) extended Golay code. . .	66
A-13	Word bit coding and interleaving. . . . .	68
A-14	Bit and word decoding . . . . .	69
A-15	Calling cycle sequences . . . . .	72
A-16	Message sequences . . . . .	74
A-17	Conclusion (terminator) sequences . . . . .	77
A-18	Basic frame structure examples. . . . .	79
A-19	LQA memory example. . . . .	94
A-20	Basic call structure. . . . .	99
A-21	Individual call protocol. . . . .	101
A-22	Individual scanning calling protocol. . . . .	104
A-23	Basic sounding structure. . . . .	113
A-24	Call rejection scanning sounding protocol . . . . .	114
A-25	Call acceptance scanning sounding protocol. . . . .	115
A-26	Scanning sounding with optional handshake protocol. . . .	118
A-27	Star net scanning calling protocol. . . . .	120
A-28	Star group scanning calling protocol. . . . .	126
A-29	Data text message structure example . . . . .	138
A-30	Data text message reconstruction (overlay). . . . .	141
A-31	Data block message structure and ARQ example. . . . .	147
A-32	Data block message interleaver and deinterleaver. . . . .	148
A-33	Data block message example. . . . .	149
A-34	Data link layer with link protection sublayer . . . . .	166
<u>TABLES</u>		
A-I	Probability of linking. . . . .	38
A-II	Channel memory example. . . . .	41
A-III	Self address memory example . . . . .	43
A-IV	Other address memory example. . . . .	45
A-V	ALE word types (preambles). . . . .	51
A-VI	Limits to calls . . . . .	58
A-VII	2/3 Majority vote decoding. . . . .	70
A-VIII	Majority word construction. . . . .	70
A-IX	Basic (38) address structures . . . . .	83
A-X	Use of "@" utility symbol . . . . .	85
A-XI	Use of "?" wildcard symbol. . . . .	90
A-XII	Basic bit-error-ratio (BER) values. . . . .	93

## MIL-STD-188-141A

## CONTENTS

<u>TABLES</u>		<u>PAGE</u>
A-XIII	ALE operational rules . . . . .	98
A-XIV	Timing. . . . .	107
A-XV	Summary of <u>COMMAND</u> functions. . . . .	130
A-XVI	Link quality analysis structure . . . . .	131
A-XVII	Data text message characteristics . . . . .	135
A-XVIII	Data text message structure . . . . .	136
A-XIX	Data block message characteristics. . . . .	146
A-XX	Data block message structure. . . . .	151
A-XXI	Cyclic redundancy check structure . . . . .	157
A-XXII	Tune and wait structure . . . . .	159
A-XXIII	Time values . . . . .	160
A-XXIV	Time-related <u>COMMAND</u> functions. . . . .	161
A-XXV	User unique <u>functions</u> structure . . . . .	164
 <u>ANNEXES</u>		
ANNEX A	DEFINITIONS OF TIMING SYMBOLS . . . . .	169
ANNEX B	TIMING. . . . .	173
ANNEX C	SUMMARY OF ALE SIGNAL PARAMETERS. . . . .	183

## MIL-STD-188-141A

## 1. SCOPE.

1.1 Scope. The purpose of this document is to establish technical parameters, in the form of mandatory standards and optional design objectives (DOs), that are considered necessary to ensure interoperability of new long-haul and tactical radio equipment in the medium frequency (MF) band and in the high frequency (HF) band. It is also the purpose of this document to establish a level of performance for new radio equipment as is considered necessary to satisfy the requirements of the majority of users. These technical parameters, therefore, represent a minimum set of interoperability and performance standards. The technical parameters of this document may be exceeded in order to satisfy certain specific requirements, provided that interoperability is maintained. That is, the capability to incorporate features such as additional standard and nonstandard interfaces is not precluded.

1.2 Applicability. This standard is mandatory within the Department of Defense (DoD) in the design and development of new MF and HF radio equipment. It is not intended that existing equipment and systems be immediately converted to comply with the provisions of this standard. New equipment and systems and those undergoing major modification or rehabilitation shall conform to this standard. If deviation from this standard is required, see the waiver procedures contained in DoD 4640.11.

1.3 Application guidance. The terms "system standard" and "design objective" (DO) are defined in FED-STD-1037. In this document, the word "shall" identifies mandatory system standards. The word "should" identifies design objectives which are desirable but not mandatory.

## MIL-STD-188-141A

## 2. APPLICABLE DOCUMENTS.

2.1 Government documents.

2.1.1 Specifications, standards, and handbooks. The following specifications, standards, and handbooks form a part of this document to the extent specified herein. Unless otherwise specified, the issues of these documents are those listed in the issue of the Department of Defense Index of Specifications and Standards (DODISS) and supplement thereto, cited in the solicitation (see 6.2).

## STANDARDS

## FEDERAL

FED-STD-1003	Telecommunications, Synchronous Bit Oriented Data Link Control Procedures (Advanced Data Communication Control Procedures)
FED-STD-1037	Glossary of Telecommunication Terms

## MILITARY

MIL-STD-188-100	Common Long Haul and Tactical Communication System Technical Standards
MIL-STD-188-110	Equipment Technical Design Standards for Common Long Haul/Tactical Data Modems
MIL-STD-188-114	Electrical Characteristics of Digital Interface Circuits
MIL-STD-188-148	(S) Interoperability Standard for Anti-Jam (AJ) Communications in the High Frequency Band (2-30 MHz) (U)

(Unless otherwise indicated, copies of Federal and military specifications, standards, and handbooks are available from the Naval Publications and Forms Center (ATTN: NPODS), 5801 Tabor Avenue, Philadelphia, PA 19120-5099.)

2.1.2 Other Government documents, drawings, and publications. The following other Government documents, drawings, and publications form a part of this document to the extent specified herein. Unless otherwise specified, the issues are those cited in the solicitation.

## U.S. DEPARTMENT OF COMMERCE

## National Telecommunications and Information Administration (NTIA)

NTIA Manual of Regulations and Procedures  
for Federal Radio Frequency Management



## MIL-STD-188-141A

(Application for copies should be addressed to the U.S. Department of Commerce, NTIA, Room 4890, 14th and Constitution Ave N.W., Washington, DC 20230.)

2.2 Non-Government publications. The following documents form a part of this document to the extent specified herein. Unless otherwise specified, the issues of the documents which are DoD adopted are those listed in the issue of the DODISS cited in the solicitation. Unless otherwise specified, the issues of documents not listed in the DODISS are the issues of the documents cited in the solicitation (see 6.2).

## INTERNATIONAL STANDARDIZATION DOCUMENTS

## North Atlantic Treaty Organization (NATO) Standardization Agreements (STANAGs)

STANAG 4203	Technical Standards for Single Channel HF Radio Equipment
STANAG 5035	Introduction of an Improved System for Maritime Air Communications on HF, LF, and UHF

(Application for copies should be addressed to: Commanding Officer, Naval Publications and Forms Center, ATTN: NPFC 106, 5801 Tabor Avenue, Philadelphia, PA 19120-5099.)

## Quadripartite Standardization Agreements (QSTAGs)

QSTAG 733	Technical Standards for Single Channel High Frequency Radio Equipment
-----------	-----------------------------------------------------------------------

(Application for copies should be addressed to: Commanding Officer, Naval Publications and Forms Center, ATTN: NPFC 106, 5801 Tabor Avenue, Philadelphia, PA 19120-5099.)

## International Telecommunications Union (ITU), Radio Regulations

CCIR Recommendation 455-1	Improved Transmission System for HF Radiotelephone Circuits
---------------------------	-------------------------------------------------------------

(Application for copies should be addressed to the General Secretariat, International Telecommunications Union, Place des Nations, CH-1211 Geneva 20, Switzerland.)

(Non-Government standards and other publications are normally available from the organizations that prepare or distribute the documents. These documents also may be available in or through libraries or other informational services.)

MIL-STD-188-141A

2.3 Order of precedence. In the event of a conflict between the text of this document and the references cited herein, the text of this document takes precedence. Nothing in this document, however, supersedes applicable laws and regulations unless a specific exemption has been obtained.

## MIL-STD-188-141A

## 3. DEFINITIONS.

3.1 Terms. Definitions of terms used in this document shall be as specified in the current edition of FED-STD-1037. In addition, the following definitions are applicable for the purposes of this standard.

Automatic link establishment (ALE). The method of automatic station contact initiation as described in appendix A of this standard.

Automatic sounding. Sounding is the ability to empirically test selected channels (and propagation paths) by providing a very brief beacon-like identifying broadcast which may be utilized by other stations to evaluate connectivity, propagation, and availability, and to select known working channels for possible later use for communications or calling. Such soundings are primarily intended to increase the efficiency of the ALE function, thereby increasing system throughput. Sounding information shall be used for reducing the set of assigned channels to be used for a particular ALE connectivity attempt.

High-performance HF data modem. High-speed (capable of at least 1200 bps) or robust data modems which incorporate sophisticated techniques for correcting or reducing the number of raw (over-the-air induced) errors.

Linked compressor and expander (Lincompex). A speech processing system consisting of a compressor and expander linked by a control channel separate from the audio (speech) channel.

Link quality analysis (LQA). The overall process by which relative measurements of signal quality are performed. This signal quality is characterized by such parameter assessments as BER, SINAD, and MP. Such assessments are stored and/or exchanged between stations for ALE decision use.

Multipath (MP). The propagation phenomenon that results in radio signals reaching the receiving antenna by two or more paths, especially when this results in signal distortion due to differential time delay.

Phase noise (dBc/Hz). The amount of single-sided phase noise, contained in a one-hertz bandwidth, produced by a carrier (signal generation) source, and referenced in decibels below the full (unsuppressed) carrier output power.

Signal plus noise plus distortion to noise plus distortion ratio (SINAD). The ratio expressed in decibels (dB) consisting of (a) the recovered audio power (original modulating audio signal plus noise plus distortion) from a modulated radio frequency carrier, and (b) any residual audio power (noise plus distortion) remaining after the original modulating audio signal is removed.

MIL-STD-188-141A

Third-order intercept point. The third-order intercept point is a standard measure of how well a receiver performs in the presence of strong nearby signals. The receiver third-order intercept point is an extrapolated convergence (not directly measureable) of a desired output (two test signals) and receiver mixer-produced third-order intermodulation distortion products.

NOTE: Testing is conducted using two frequencies,  $f_1$  and  $f_2$ , which fall within the first intermediate frequency mixer passband. (In general, the test frequencies will be about 20-30 kHz apart.)

## MIL-STD-188-141A

3.2 Abbreviations and acronyms. The abbreviations and acronyms used in this document are defined below. Those listed in the current edition of FED-STD-1037 have been included for the convenience of the reader.

ABCA	American, British, Canadian, and Australian (Armies)
ACK	acknowledgement
AGC	automatic gain control
ALC	automatic level control
ALE	automatic link establishment
AMD	automatic message display
ANSI	American National Standards Institute
ARQ	automatic repeat request
ASCII	American Standard Code for Information Interchange
BER	bit error ratio
CCEP	Commercial COMSEC Endorsement Program
CCIR	International Radio Consultative Committee
COMSEC	Communications Security
CRC	cyclic redundancy check
DBM	data block message
DCA	Defense Communications Agency
DCAC	Defense Communications Agency Circular
DCE	data circuit-terminating equipment
DCS	Defense Communications System
DoD	Department of Defense
DODISS	Department of Defense Index of Specifications and Standards
DTE	data terminal equipment
DTM	data text message
EDC	error detection and correction

## MIL-STD-188-141A

FCS	frame check sequence
FDM	frequency-division multiplexing
FEC	forward error correction
FIPS	Federal Information Processing Standards
FSK	frequency-shift keying
ICW	interrupted continuous wave
IMD	intermodulation distortion
ISB	independent sideband (transmission)
ISDN	Integrated Services Digital Network
ISO	International Organization for Standardization
ITU	International Telecommunications Union
JCS	Joint Chiefs of Staff
LQA	link quality analysis
LSB	(1) lower sideband (radio); (2) least significant bit (data)
MSB	most significant bit
NAK	nonacknowledgement (request for repeat)
NATO	North Atlantic Treaty Organization
NBFM	narrowband frequency modulation
NMCS	National Military Command System
NSA	National Security Agency
NTIA	National Telecommunications and Information Administration
OSI	Open Systems Interconnection
PEP	peak envelope power
PTT	push to talk
QSTAG	Quadripartite Standardization Agreement
RTTY	radio teletypewriter

MIL-STD-188-141A

SINAD	signal plus noise plus distortion to noise plus distortion ratio
SNR	signal-to-noise ratio
SSB	single sideband
STANAG	Standardization Agreement (NATO)
USB	upper sideband
UUF	user unique function
VFCT	voice frequency carrier telegraph
VSWR	voltage standing wave ratio

## MIL-STD-188-141A

## 4. GENERAL REQUIREMENTS.

4.1 General. By convention, frequency band allocation for the MF band is from 0.3 megahertz (MHz) to 3 MHz and the HF band is from 3 MHz to 30 MHz. However, for military purposes, equipment designed for HF band use has historically been designed with frequency coverage extending into the MF band. For new HF equipment, HF band standard parameters shall apply to any portion of the MF band included as extended coverage. Currently there are no known military requirements below 1.5 MHz. Consequently, this portion of the MF band is not standardized.

Equipment parameters will be categorized using functional use groups for radio assemblages/sets. Historically, these groups have been fixed (long-haul) installations and tactical sets. The tactical sets are subgrouped further into vehicle transportable and manpack versions. Although these distinctions still exist in principle, the former lines of distinction have become somewhat blurred. The mobility of current military forces dictates that a significant number of long-haul requirements will be met with transportable systems, and in some cases, such systems are implemented with design components shared with manpack radios. When such "tactical" equipment is used to meet a long-haul requirement, the equipment shall meet long-haul minimum performance standards. Accordingly, within this standard, tactical use groups may contain dual-value parameters. One parameter reflects usage wherein the frequency-determining elements are temperature controlled. The other usage is deployment related, wherein the frequency-determining elements are not temperature controlled (the usual condition for manpack equipment in tactical operations).

4.2 Equipment operation modes.

4.2.1 Baseline mode. Frequency control of all new HF equipment shall be capable of being stabilized by an external standard. Should multiple-frequency (channel) storage be incorporated, it shall be of the programmable-memory type and be capable of storing/initializing the operational mode (see 4.2.1.1 and 4.2.1.2 below, and 40.2 of appendix A) associated with each particular channel.

4.2.1.1 Single-channel. All new single-channel HF equipment shall provide, as a minimum, the capability for the following one-at-a-time selectable operational modes:

- a. One nominal 3-kHz channel upper sideband (USB) or lower sideband (LSB)(selectable).
- b. One (rate-dependent bandwidth) interrupted continuous wave (ICW) channel.
- c. A narrowband frequency modulation (NBFM) channel capability should be included as a design objective (DO).



## MIL-STD-188-141A

4.2.1.2 Multichannel. All new multichannel HF equipment shall provide, as a minimum, the capability for single-channel operation as set forth in 4.2.1.1 above and the following one-at-a-time selectable operational modes:

- a. Two nominal 3-kHz channels in the USB or LSB (two independent channels in the same sideband--sideband selectable).
- b. One nominal 6-kHz channel in the USB or LSB (selectable).
- c. Two nominal 3-kHz channels in the USB and two in the LSB (four independent 3-kHz channels--two in each sideband).
- d. One nominal 6-kHz channel in the USB and one in the LSB (two independent 6-kHz channels--one in each sideband).
- e. One nominal 3-kHz channel in the USB and one in the LSB (two independent 3-kHz channels--one in each sideband).

4.2.2 Automatic link establishment (ALE) mode. Should an ALE capability be included, it shall be of the channel-scanning type and shall provide for contact initiation by either or both manual and automated control. See 4.5 for the list of features required to support this operational mode.

4.2.3 Anti-jam (AJ) mode. If AJ is to be implemented, the AJ capabilities and features for HF radios shall be in accordance with MIL-STD-188-148.

#### 4.3 Interface parameters.

4.3.1 Electrical characteristics of digital interfaces. As a minimum, any incorporated interfaces for serial binary data shall be in accordance with the provisions of MIL-STD-188-114. Such interfaces shall also include provisions for request-to-send and clear-to-send signaling. The capability to accept additional standard interfaces is not precluded.

4.3.2 Electrical characteristics of analog interfaces. See 5.3.6 and 5.4.5.

4.3.3 Modulation and data signaling rates. The modulation rate (expressed in baud (Bd)) or the data signaling rate (expressed in bits per second (bps)) at interface points A and A' on figure 1 shall include those contained in the HF modem portion of MIL-STD-188-110.

#### 4.4 North Atlantic Treaty Organization (NATO) and Quadripartite interoperability requirements.

4.4.1 Single-channel communications systems. For interoperation with NATO member nations, land, air, and maritime, single-channel HF radio equipment shall comply with the applicable requirements of the current edition of STANAG 4203.

MIL-STD-188-141A

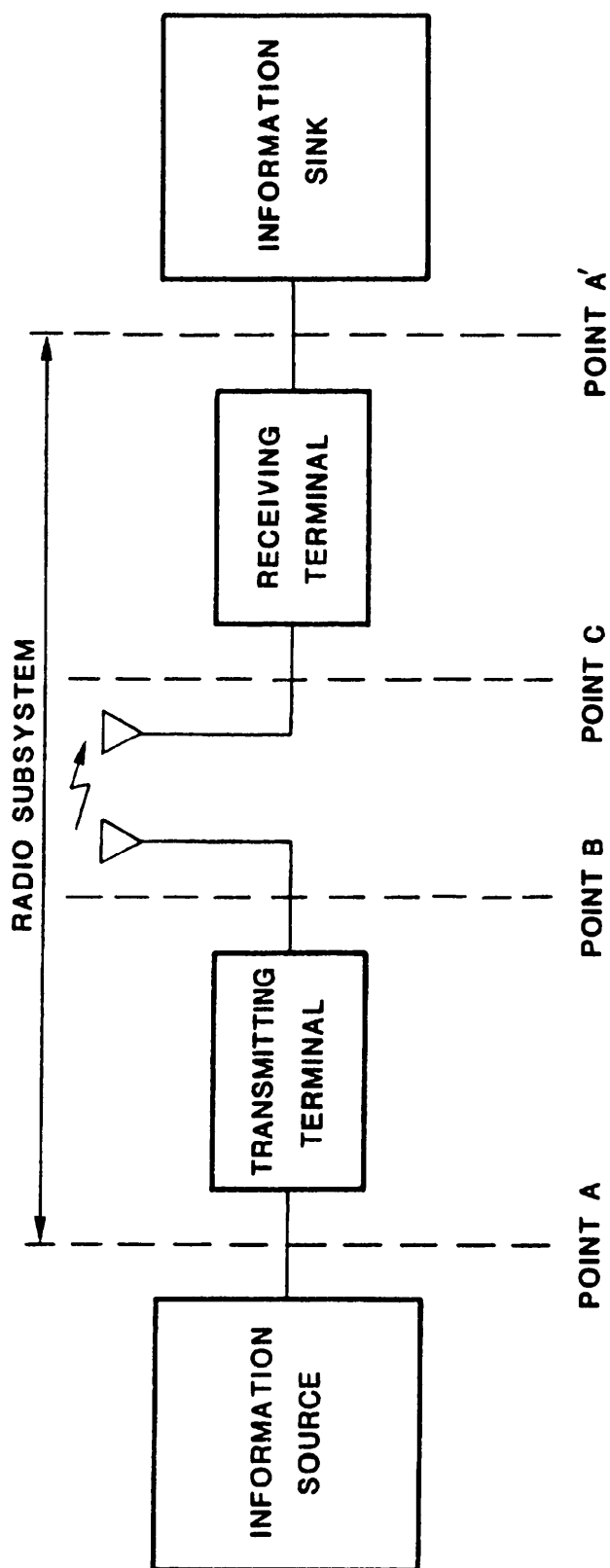

FIGURE 1. Radio subsystem interface points.

## MIL-STD-188-141A

4.4.2 Maritime air communications systems. For interoperation with NATO member nations, HF maritime air communications systems shall comply with the applicable requirements of the current edition of STANAG 5035.

4.4.3 High-performance HF data modems. For interoperation with NATO member nations, land, air, and maritime, single-channel HF radio equipment shall comply with the applicable requirements of the appropriate STANAG.

4.4.4 Quadripartite Standardization Agreements (QSTAGs). For interoperation among American, British, Canadian, and Australian (ABCA) Armies, HF combat net radio equipment shall comply with the applicable requirements of the current edition of QSTAG 733.

4.5 Adaptive communications. Adaptive HF describes any HF communications system that has the ability to sense its communications environment, and, if required, to automatically adjust operations to improve communications performance. Should the user elect to incorporate adaptive features, they shall be in accordance with the requirements for those features stated in this document.

The essential adaptive features are:

- a. Channel (frequency) scanning capability.
- b. Automatic link establishment (ALE) using an embedded selective calling capability. A disabling capability and an option to inhibit responses shall be included.
- c. Automatic sounding (station-identifiable transmissions). A capability to disable sounding and an option to inhibit responses shall be included.
- d. Limited link quality analysis (LQA) for assisting the ALE function:
  - (1) Relative data error assessment.
  - (2) Relative SINAD (optional).
  - (3) Multipath/distortion assessment (DO).

## MIL-STD-188-141A

## 5. DETAILED REQUIREMENTS.

5.1 General.

5.1.1 Introduction. This section provides detailed performance standards for ~~MF~~ and ~~HF~~ radio equipment. These performance standards shall apply over the appropriate frequency range from 2.0 MHz to 29.9999 MHz (DO: 1.5 MHz to 30.0 MHz).

5.1.2 Signal and noise relationships. The signal and noise relationships are expressed as signal plus noise plus distortion to noise plus distortion ratio (SINAD), unless otherwise identified. Unless otherwise specified, when the ratio is stated, the noise bandwidth is 3 kHz.

5.2 Common equipment characteristics. These characteristics shall apply to each transmitter and to each receiver unless otherwise specified.

5.2.1 Displayed frequency. The displayed frequency shall be that of the carrier, whether suppressed or not.

5.2.2 Frequency coverage. The radio equipment shall be capable of operation over the frequency range of 2.0 MHz to 29.9999 MHz in a maximum of 100-Hz frequency increments (DO: 10-Hz) for single-channel equipment, and 10-Hz frequency increments (DO: 1-Hz) for multichannel equipment.

5.2.3 Frequency accuracy. The accuracy of the radio carrier frequency, including tolerance and long-term stability but not any variation due to doppler shift, shall be within +30 Hz for manpack equipment and within +10 Hz for all others, measured during a period of not less than 30 days.

5.2.4 Phase stability. The phase stability shall be such that the probability that the phase difference will exceed 5 degrees over any two successive 10 millisecond (ms) periods (13.33-ms periods may also be used) shall be less than one percent. Measurements shall be performed over a sufficient number of adjacent periods to establish the specified probability with a confidence of at least 95 percent.

5.2.5 Phase noise. The synthesizer and mixer phase-noise spectrum at the transmitter output shall not exceed those limits as depicted on figures 2 and 3 under continuous carrier single-tone output conditions. Figure 2 depicts the limits of phase noise for fixed-site and transportable long-haul radio transmitters. Figure 3 depicts the limits for tactical radio transmitters. See 4.1 for application statements on dual parameters.

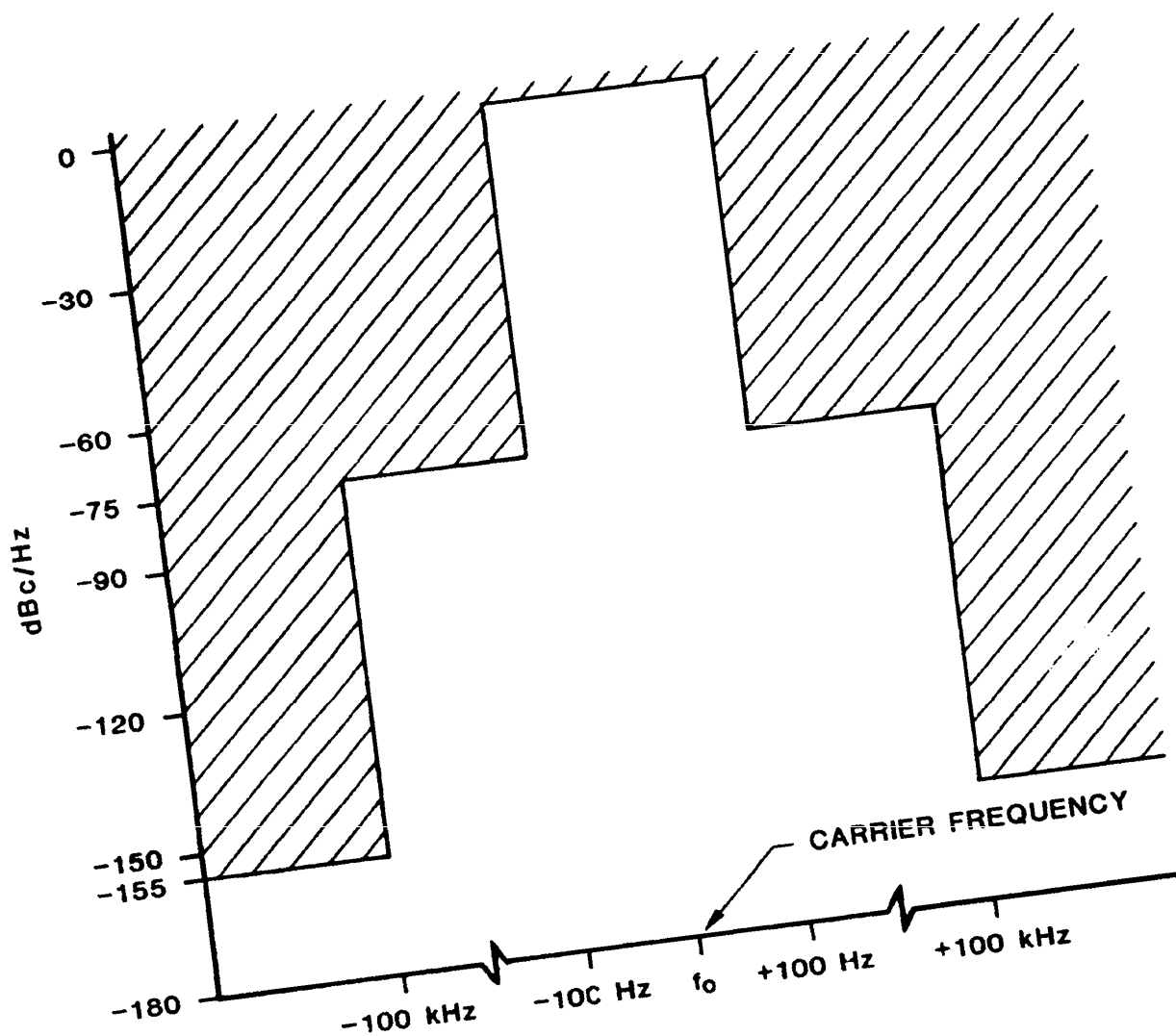

**NOTE:**  
dBc = DECIBELS REFERENCED TO A FULL-RATED PEP CARRIER OUTPUT.

FIGURE 2. Phase noise limit mask for fixed site and transportable long-haul radio transmitters with temperature-controlled frequency-determining elements.

## MIL-STD-188-141A

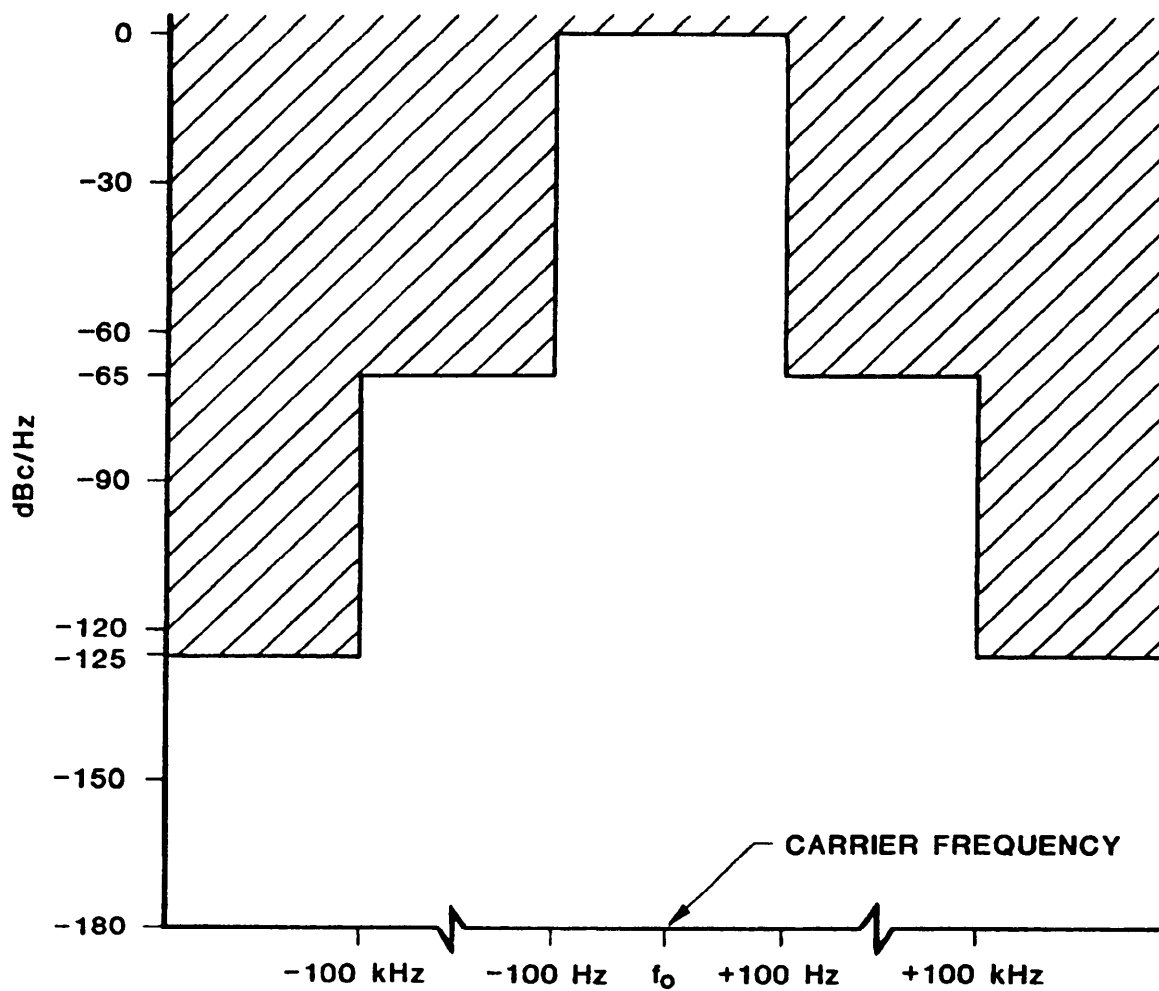
**NOTE:**

**dBc = DECIBELS REFERENCED TO A FULL-RATED PEP CARRIER OUTPUT.**

FIGURE 3. Phase noise limit mask for tactical radio transmitters without temperature-controlled frequency-determining elements.

## MIL-STD-188-141A

5.2.6 Bandwidths. The bandwidths for high frequency band emissions shall be as shown in table I and on figures 4 and 5. Other high frequency band emissions which may be required to satisfy specific user requirements can be found in the NTIA Manual of Regulations and Procedures for Federal Radio Frequency Management.

TABLE I. Bandwidths.

Emissions type	Maximum allowable bandwidth (kHz)
Interrupted continuous wave (ICW)	0.5
Frequency-shift keying (FSK) (85-Hz shift)	0.3
Frequency-shift keying (FSK) (850-Hz shift)	1.1
Single-sideband modulation (SSB), single-channel	2.8
Independent-sideband modulation (ISB),	
two channels	6.1
four channels	12.4

5.2.7 Overall channel responses.

5.2.7.1 Single-channel or dual-channel operation. The amplitude vs. frequency response between ( $f_0 + 300$  Hz) and ( $f_0 + 3050$  Hz) shall be within 2 dB (total) where  $f_0$  is the carrier frequency. The attenuation shall be at least 20 dB from  $f_0$  to ( $f_0 - 415$  Hz), at least 40 dB from ( $f_0 - 415$  Hz) to ( $f_0 - 1000$  Hz), and at least 60 dB below ( $f_0 - 1000$  Hz). Attenuation shall be at least 30 dB from ( $f_0 + 4000$  Hz) to ( $f_0 + 5000$  Hz) and at least 60 dB above ( $f_0 + 5000$  Hz). See figure 4. Group delay time shall not vary by more than 0.5 ms over the passband of 300 Hz to 3050 Hz. Measurements shall be performed end-to-end (transmitter audio input to receiver audio output) with the radio equipment configured in a back-to-back test setup.

NOTE: Although the response values given are for single-channel USB operation, an identical shape, but inverted channel response, is required for LSB or the inverted channel of a dual-channel independent sideband operation.

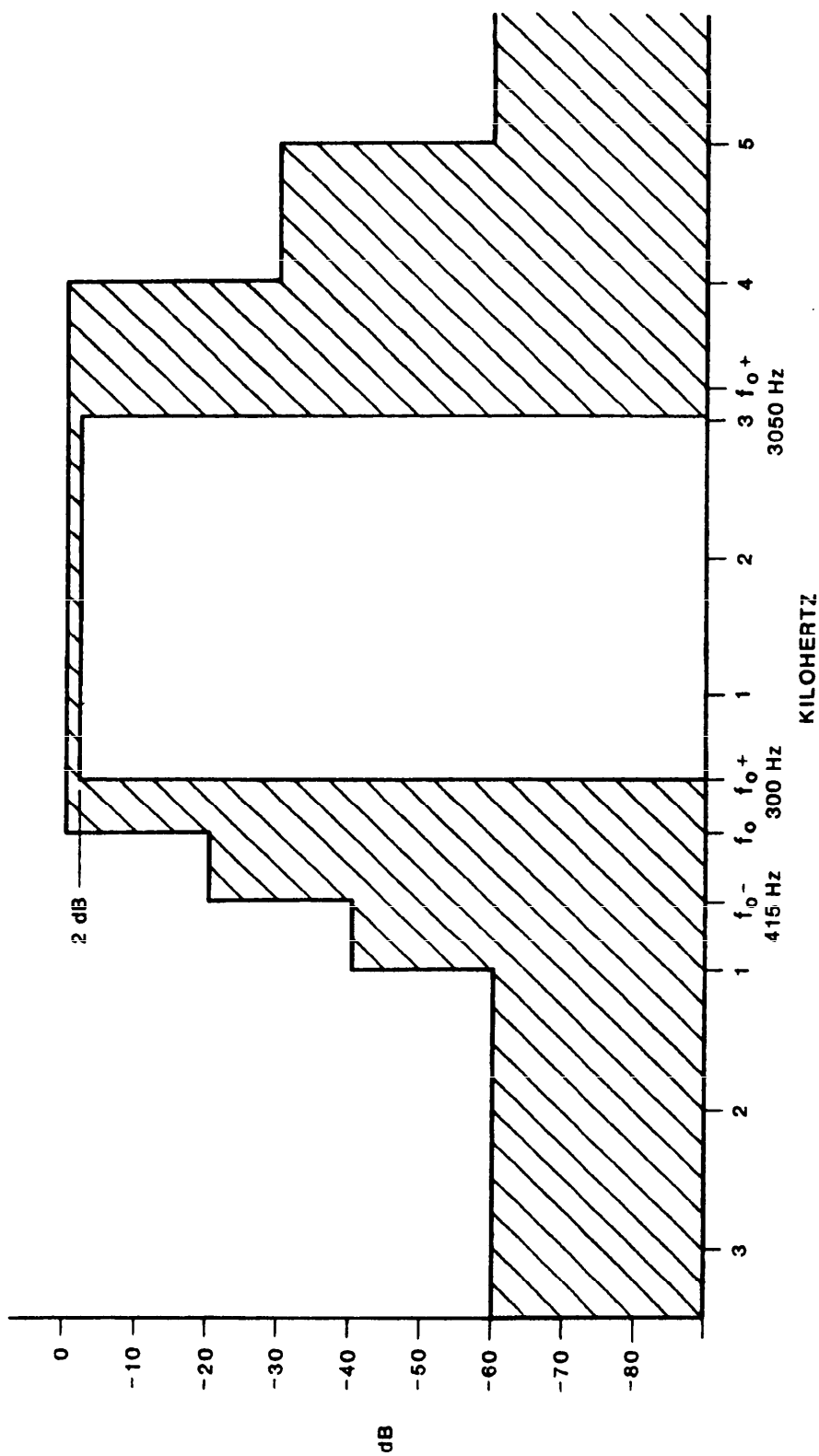

**NOTES:**

1. CHANNEL RESPONSE SHALL BE WITHIN SHADED PORTION OF CURVE (A1 SHOWN).
2.  $f_0$  FOR A SINGLE CHANNEL IS THE CARRIER FREQUENCY.
3.  $f_0$  FOR 2 CHANNEL ISB IS THE CENTER FREQUENCY.

FIGURE 4. Overall channel response for single-channel or dual-channel equipment.



MIL-STD-188-141A

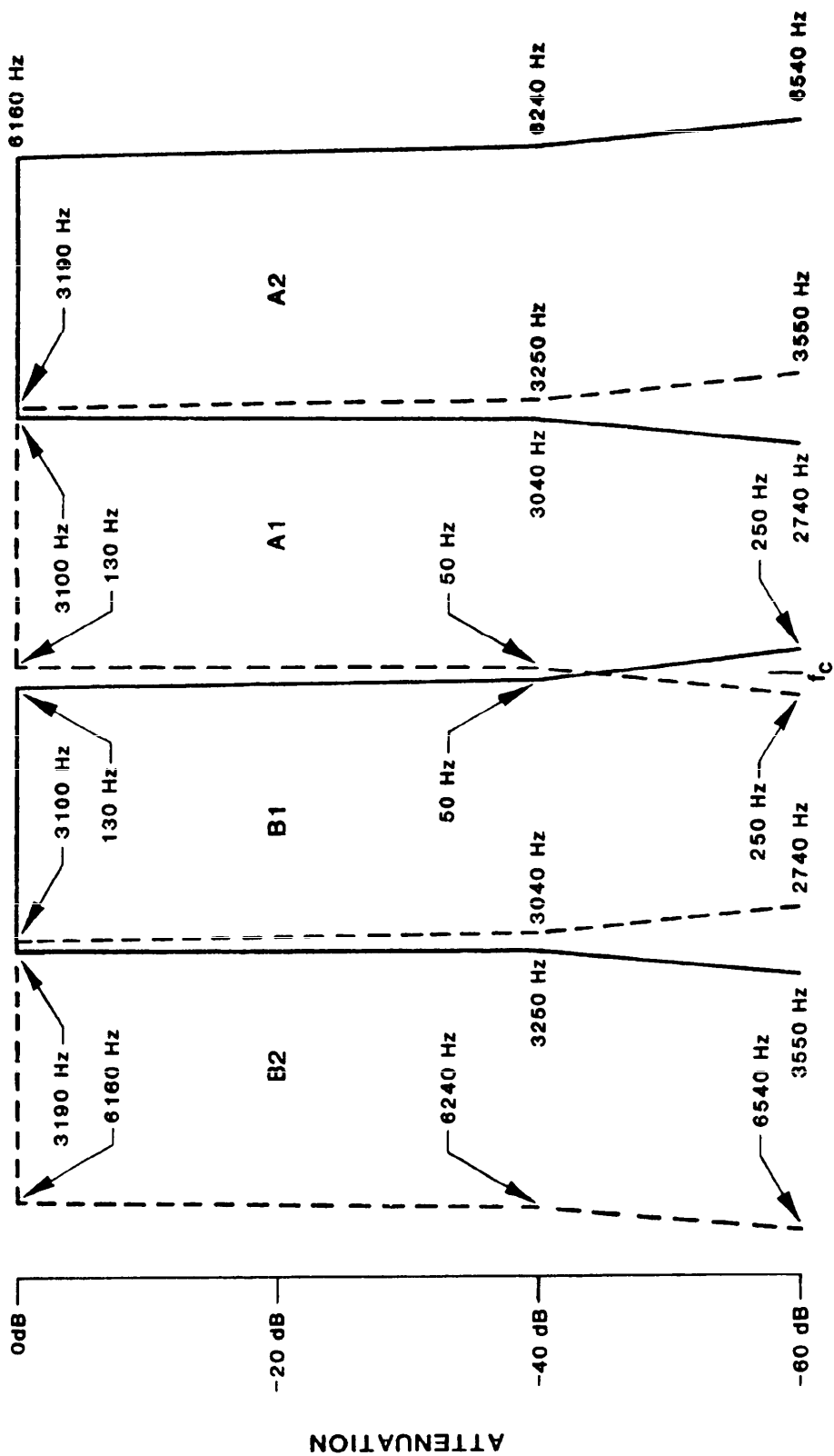

NOTES:

1. THE VIRTUAL SUBCARRIER FOR THE A2 AND B2 INVERTED CHANNELS SHALL BE  $f_c \pm 6290$  Hz.
2. FREQUENCIES SHOWN ARE AT THE FILTER dB (BREAK POINT) LEVELS NOTED.

FIGURE 5. Overall channel characteristics (four-channel equipment).

## MIL-STD-188-141A

5.2.7.2 Four-channel operation. When four-channel independent sideband operation is employed, the four individual 3-kHz channels shall be configured as shown on figure 5, which also shows the amplitude response for these four channels. Channels A2 and B2 shall be inverted and displaced with respect to channels A1 and B1 as shown on the figure. This can be accomplished by using subcarrier frequencies of 6290 Hz above and below the center carrier frequency, or by other suitable techniques which produce the required channel displacements and inversions. The suppression of any subcarriers used shall be at least 40 dB (DO: 50 dB) below the level of a single tone in the A2 or B2 channel modulating the transmitter to 25 percent of peak envelope power (PEP). See figure 5. The rf amplitude versus frequency response for each individual ISB channel shall be within 2 dB (DO: 1 dB) between 250 Hz and 3100 Hz, referenced to each channel's carrier (either actual or virtual). Referenced from each channel's carrier, the channel attenuation shall be at least 40 dB at 50 Hz and 3250 Hz, and at least 60 dB at -250 Hz and 3550 Hz. Group delay distortion shall not exceed 1500 microseconds over the ranges 370 Hz to 750 Hz and 3000 Hz to 3100 Hz. The distortion shall not exceed 500 microseconds over the range 750 Hz to 3000 Hz. Group delay distortion shall not exceed 150 microseconds for any 100-Hz frequency increment between 750 Hz and 3000 Hz. Measurements shall be performed end-to-end (transmitter audio input to receiver audio output) with the radio equipment configured in a back-to-back test setup.

NOTE 1: For voice operations, each independent sideband channel audio input requires a low-pass filter with at least 40-dB attenuation at 2740 Hz.

NOTE 2: When using multichannel voice frequency carrier telegraph (VFCT) modulation, as specified in table 5.2-1 of MIL-STD-188-100, do not use channel 16 (frequencies of 2932.5 Hz, 2975 Hz, and 3017.5 Hz).

5.2.8 Absolute delay. The absolute delay shall not exceed 10 milliseconds (ms) (DO: 5 ms) over the frequency range of 300 Hz to 3050 Hz. The delay shall not vary by more than +0.5 ms from the measured initial value. Measurements shall be performed end-to-end and back-to-back as in 5.2.7.1.

5.2.9 Lincompex. Should a voice compression and expansion capability be included, it shall meet CCIR 455-1 Lincompex requirements. In addition, such a device shall incorporate calibration techniques that automatically remove radio-link frequency errors for the receiver expander function with the start of reception of each Lincompex transmission. The calibration sequence is shown on figure 6.

### 5.3 Transmitter characteristics.

#### 5.3.1 Noise and distortion.

5.3.1.1 In-band noise. Broadband noise in a 1-Hz bandwidth within the selected sideband shall be at least 85 dBc below the level of the rated peak envelope power (PEP) of the HF transmitter.

MIL-STD-188-141A

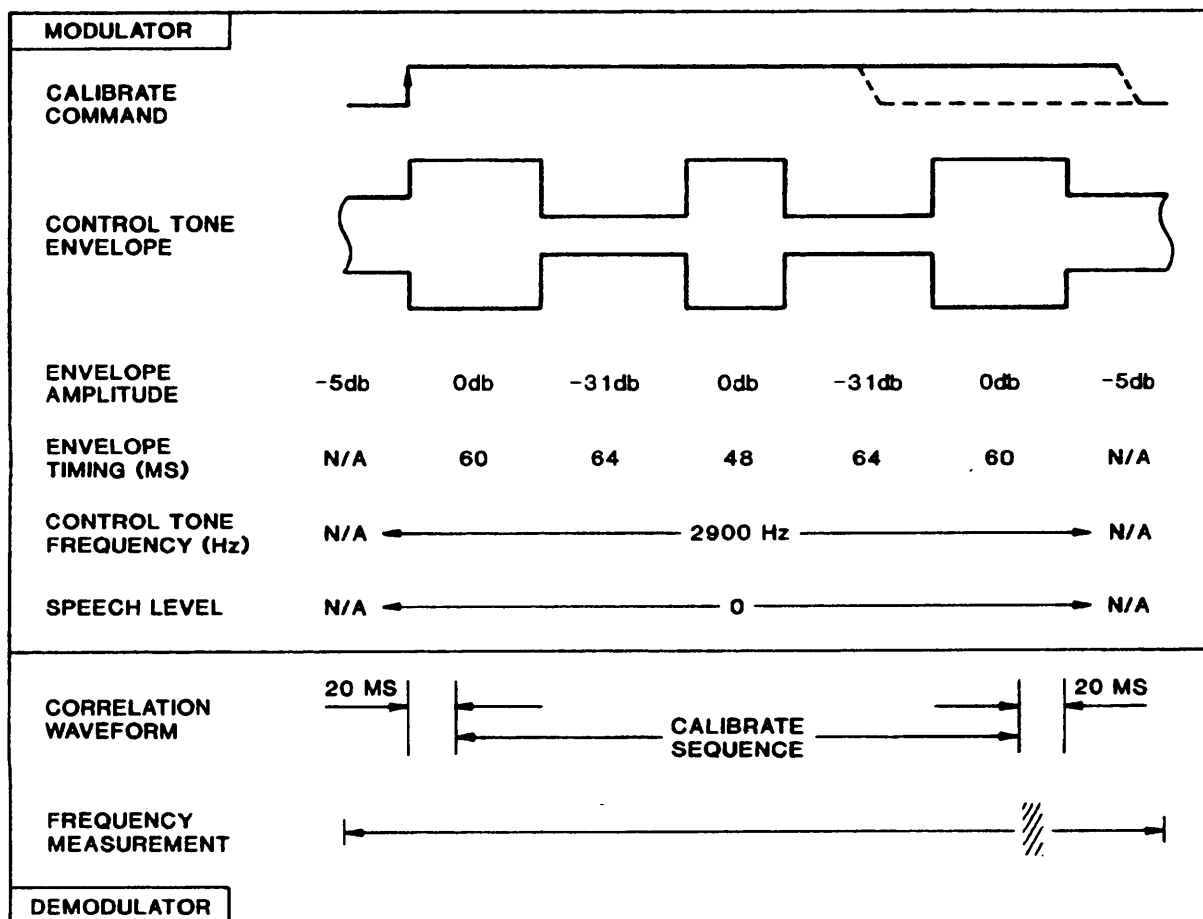

FIGURE 6. Lincompex calibration sequence.

## MIL-STD-188-141A

5.3.1.2 Intermodulation distortion (IMD). The IMD products of HF transmitters produced by any two equal-level, single-frequency audio test signals between 300 Hz and 3050 Hz, shall be at least 30 dB below each reference tone when the transmitter is operating at rated PEP. The frequencies of the two audio test signals shall not be harmonically or subharmonically related and shall have a minimum separation of 300 Hz.

5.3.2 Spectral purity.

5.3.2.1 Broadband emissions. When the transmitter is driven with a single tone to the rated PEP, the power spectral density of the transmitter broadband emission shall not exceed the level established in table II and as shown on figure 7. Discrete spurs shall be excluded from the measurement, and the measurement bandwidth shall be 1 Hz.

TABLE II. Out-of-band power spectral density limits for radio transmitters.

Frequency (Hz)	Attenuation below in-band power density (dB)
$f_m = f_c \pm (0.5 B + 500)$	40 (D0: 43)
$f_m = f_c \pm 1.0 B$	45 (D0: 48)
$f_m = f_c \pm 2.5 B$	60 (D0: 80)
$(f_c + 4.0 B) \leq f_m \leq 1.05 f_c$ $0.95 f_c \leq f_m \leq (f_c - 4.0 B)$	70 (D0: 80)
$f_m \leq 0.95 f_c$ $f_m \geq 1.05 f_c$	90 (D0: 120)

where:  $f_m$  = frequency of measurement (Hz)  
 $f_c$  = center frequency of bandwidth (Hz)  
 $B$  = bandwidth (Hz)

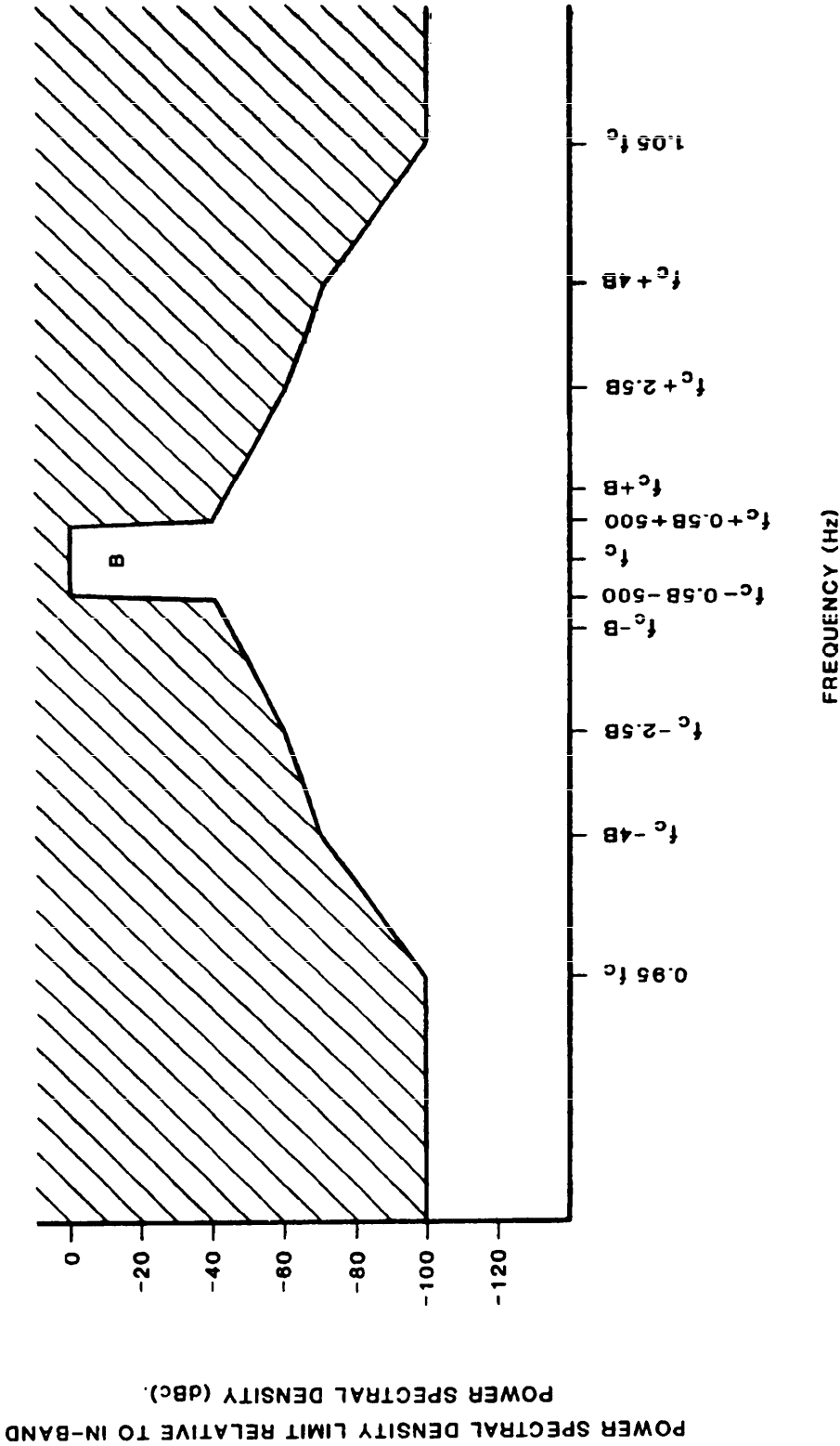

**NOTES:**

1. B = NECESSARY BANDWIDTH (Hz).
2.  $f_c$  = CENTER FREQUENCY OF BANDWIDTH (Hz).
3. EMISSIONS SHALL FALL WITHIN THE UNSHADED PORTION OF THE CURVE.

FIGURE 7. Out-of-band power spectral density for HF transmitters.

## MIL-STD-188-141A

5.3.2.2 Discrete frequency spurious emissions. For HF transmitters, when driven with a single tone to produce an rf output of 25-percent rated PEP, all discrete frequency spurious emissions shall be suppressed as follows:

- o Between the carrier frequency and  $4B$  (where  $B$  = bandwidth), at least 40 dBc.
- o Between  $4B$  and +5 percent of  $f_c$  removed from the carrier frequency, at least 60 dBc.
- o Beyond +5 percent removed from the carrier frequency, at least 80 dBc. See figure 8.

5.3.3 Carrier suppression. The suppressed carrier shall be at least 50 dBc (D0: 60 dBc) below the output level of a single tone modulating the transmitter to rated PEP.

5.3.4 Automatic level control (ALC). Starting at ALC threshold, an increase of 20 dB in audio input shall result in less than a 1-dB increase in average rf power output.

5.3.5 Attack and release time delays.

5.3.5.1 Attack-time delay. The time interval from keying-on a transmitter until the transmitted rf signal amplitude has increased to 90 percent of its steady-state value shall not exceed 25 ms (D0: 10 ms). This delay excludes any necessary time for automatic antenna tuning.

5.3.5.2 Release-time delay. The time interval from keying-off a transmitter until the transmitted rf signal amplitude has decreased to 10 percent of its key-on steady-state value shall be 10 ms or less.

5.3.6 Signal input interface characteristics.

5.3.6.1 Input signal power. Input signal power for microphone or handset input is not standardized. Where provided, the line input signal power range shall be such that the transmitter rated PEP is obtained without manual adjustment or gain controls. For any two-tone signal input, the amplitude can vary from -23 dBm to 0 dBm per tone. For single-tone input, the amplitude can vary from -17 dBm to +6 dBm.

5.3.6.2 Input audio signal interface.

5.3.6.2.1 Unbalanced interface. An unbalanced interface shall be provided with an audio input impedance of a nominal 150 ohms, unbalanced with respect to ground, with a minimum return loss of 20 dB against a 150-ohm resistance over the frequency range of 300 Hz to 3050 Hz.

5.3.6.2.2 Balanced interface. When a balanced interface is provided, the audio input impedance shall be a nominal 600 ohms, balanced with respect to ground, with a minimum return loss of 26 dB against a 600-ohm resistance over the frequency range of 300 Hz to 3050 Hz. The electrical symmetry shall be sufficient to suppress longitudinal currents at least 40 dB below the reference signal level.

MIL-STD-188-141A

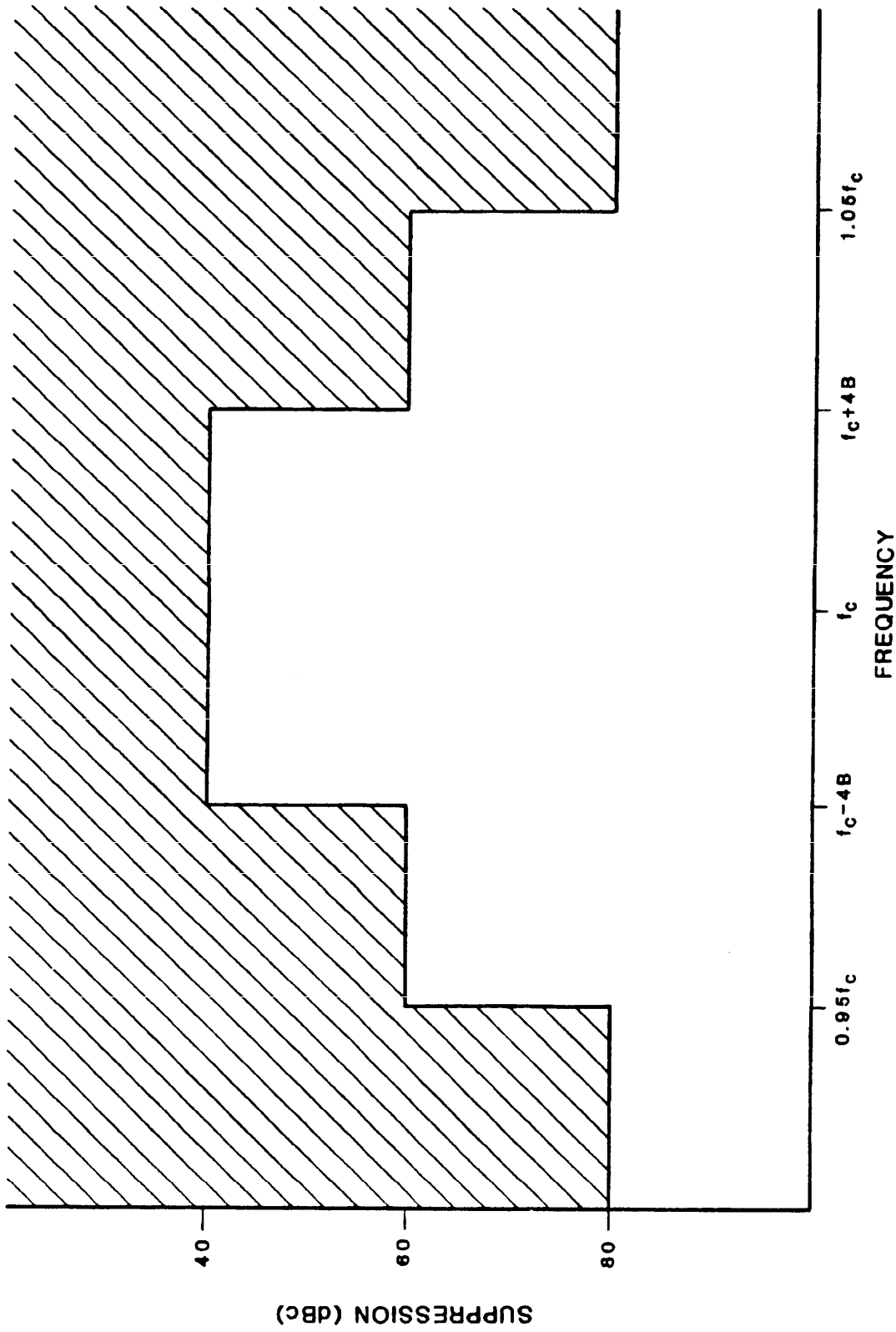

**NOTE:**

EMISSIONS SHALL FALL WITHIN THE UNSHADED PORTION OF THE CURVE.

FIGURE 8. Discrete spurious emissions limit for HF transmitters.

## MIL-STD-188-141A

5.3.7 Transmitter output load impedance. The nominal rf output load impedance at interface point B on figure 1 shall be 50 ohms, unbalanced with respect to ground. Transmitters with power output ratings equal to or less than 600 watts shall provide: (a) full-rated output power for VSWRs of 2:1 or less, and (b) power output derated by a factor not greater than 1.5/VSWR for VSWRs above 2:1. See figure 9a. Transmitters with power output ratings of greater than 600 watts shall derate their output power by a factor of not greater than 1/VSWR. See figure 9b. On transmitters using separate exciters, the interface between the exciter and amplifier shall be a nominal 50 ohms, unbalanced, with a maximum VSWR of 1.5:1 over the operating frequency range.

NOTE: The full-rated output power of a transmitter, over the operating frequency range, is defined to be (a) the rated PEP when the transmitter is driven by a two-tone signal consisting of equal amplitude tones, and (b) the rated average power when driven by a single tone. The output rating shall be determined with the transmitter operating into a 50-ohm load.

#### 5.4 Receiver characteristics.

5.4.1 Receiver rf characteristics. All receiver input amplitudes are in terms of available power in dBm from a 50-ohm source impedance signal generator.

5.4.1.1 Image rejection. The rejection of image signals shall be at least 80 dB for HF receivers (D0: 100 dB).

5.4.1.2 Intermediate-frequency (IF) rejection. Signals at the intermediate frequency (frequencies) shall be rejected by at least 80 dB (D0: 100 dB).

5.4.1.3 Adjacent-channel rejection. The receiver shall reject any signal in the undesired sideband and adjacent channel in accordance with figure 4.

5.4.1.4 Other single-frequency external spurious responses. Receiver rejection of spurious frequencies, other than IF and image, shall be at least 65 dB for frequencies from +2.5 percent to +30 percent, and from -2.5 percent to -30 percent of the center frequency, and at least 80 dB for frequencies beyond +30 percent of the center frequency.

5.4.1.5 Receiver protection. The receiver, with primary power on or off, shall be capable of survival without damage with continuously applied signals of up to +43 dBm (D0: +53 dBm) available power delivered from a 50-ohm source.



MIL-STD-188-141A

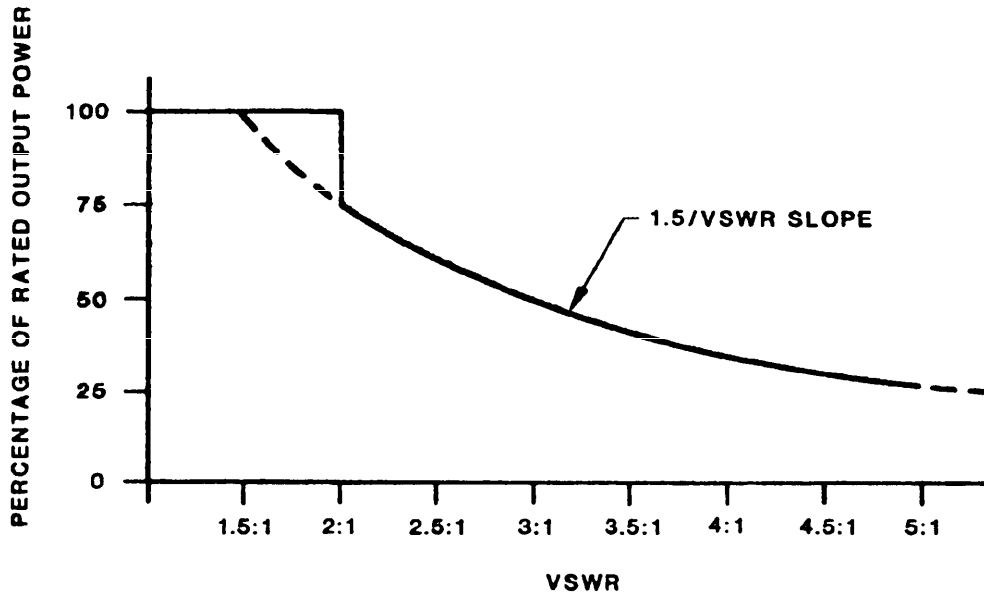

A. 600 WATTS OR LESS

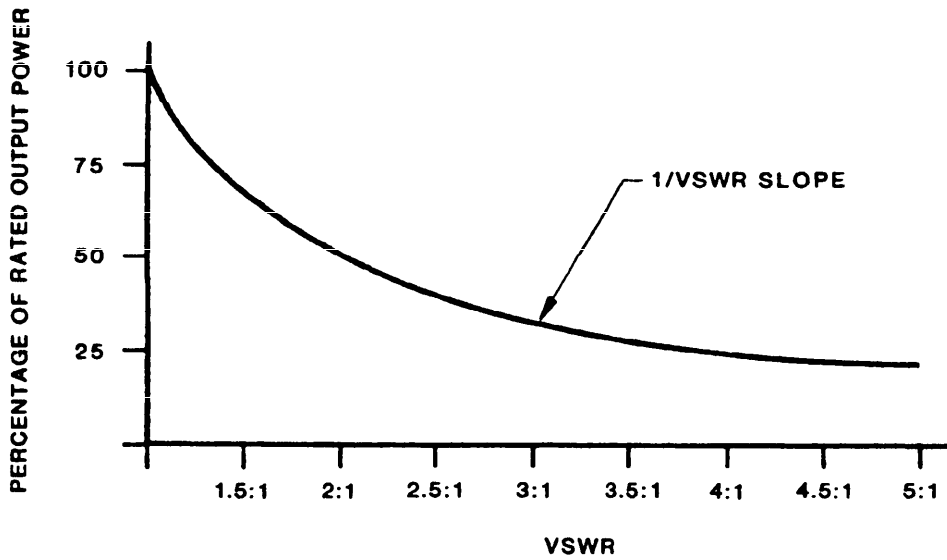

B. GREATER THAN 600 WATTS

FIGURE 9. Output power vs. VSWR for transmitters with broadband output impedance networks.

## MIL-STD-188-141A

5.4.1.6 Desensitization dynamic range. The following requirement shall apply to the receiver in an SSB mode of operation with an IF passband setting providing at least 2750 Hz (300 Hz to 3050 Hz) of bandwidth at the 2-dB points. With the receiver tuning centered on a sinusoidal input test signal and with the test signal level adjusted to produce an output SINAD of 10 dB, a single interfering sinusoidal signal, offset from the test signal by an amount equal to +5 percent of the carrier frequency, is injected into the receiver input. The output SINAD shall not be degraded by more than 1 dB as follows:

- a. For radios whose frequency-determining elements are temperature controlled, the interfering signal is equal to or less than 100 dB above the test signal level.
- b. For radios whose frequency-determining elements are not temperature controlled, the interfering signal is equal to or less than 90 dB above the test signal level.

5.4.1.7 Receiver sensitivity. The sensitivity of the receiver over the operating frequency range, in the sideband mode of operation (3-kHz bandwidth), shall be such that a -111 dBm (DO: -121 dBm) unmodulated signal at the antenna terminal, adjusted for a 1000-Hz audio output, produces an audio output with a SINAD of at least 10 dB over the operating frequency range.

5.4.1.8 Receiver out-of-band IMD. Second-order and higher-order responses shall require a two-tone signal amplitude with each tone at least 80 dB greater than that required for a single-tone input to produce an output SINAD of 10 dB. This requirement is applicable for equal-amplitude input signals with the closest signal spaced 30 kHz or more from the operating frequency.

5.4.1.9 Third-order intercept point. Using test signals within the first IF passband, the worst-case third-order intercept point shall not be less than +10 dBm.

#### 5.4.2 Receiver distortion and internally generated spurious outputs.

5.4.2.1 Overall IMD (in-channel). The total of IMD products, with two equal-amplitude, in-channel tones spaced 110 Hz apart, present at the receiver rf input, shall meet the following requirements. For frequency division multiplex (FDM) service, the receiver shall meet the requirements for any tone spacing equal to or greater than the minimum between adjacent tones in any FDM library. The requirements shall be met for any rf input amplitude of 0 dBm PEP (-6 dBm/tone) and for any audio output of +12 dBm PEP (+6 dBm/tone) or less. All IMD products shall be at least 35 dB (DO: 45 dB) below the output level of either of the two tones.

## MIL-STD-188-141A

5.4.2.2 Adjacent-channel IMD. For multiple-channel equipment, the overall adjacent-channel IMD in each 3-kHz channel being measured shall not be greater than -35 dBm at the 3-kHz channel output with all other channels equally loaded with 0 dBm unweighted white noise.

5.4.2.3 Audio frequency total harmonic distortion. The total harmonic distortion produced by any single-frequency rf test signal, which produces a frequency within the frequency bandwidth of 300 Hz to 3050 Hz, shall be at least 25 dB (DO: 35 dB) below the reference tone level with the receiver at rated output level. The rf test signal shall be at least 35 dB above the receiver noise threshold.

5.4.2.4 Internally generated spurious outputs. Spurious signals at the output of the receiver, produced in the absence of rf signals by mixing of signals that are generated internally in the receiver, shall not exceed -112 dBm (DO: -122 dBm).

5.4.3 Automatic gain control (AGC) characteristic. The steady-state output level of the receiver (for a single tone) shall not vary by more than 3 dB over an rf input range from -103 dBm to +13 dBm.

5.4.3.1 AGC attack time (nondata modes). The receiver AGC attack time shall not exceed 30 ms.

5.4.3.2 AGC release time (nondata modes). The receiver AGC release time shall be between 800 and 1200 ms for SSB voice and ICW operation. This shall be the period from rf signal downward transition until audio output is within 3 dB of the steady-state output. The final steady-state audio output is simply receiver noise being amplified in the absence of any rf input signal.

5.4.3.3 AGC requirements for data service. In data service, the receiver AGC attack time shall not exceed 10 ms. The AGC release time shall not exceed 25 ms.

5.4.4 Receiver linearity. The following shall apply with the receiver operating at maximum sensitivity, and with a reference input signal that produces a SINAD of 10 dB at the receiver output. The output SINAD shall increase monotonically and linearly within + 10 percent for a linear increase in input signal level until the output SINAD is equal to at least 40 dB (DO: 60 dB). This requirement shall apply over the operating frequency range of the receiver.

5.4.5 Interface characteristics.

5.4.5.1 Input impedance. The receiver rf input impedance shall be nominally 50 ohms, unbalanced with respect to ground. The input voltage standing wave ratio (VSWR), with respect to 50 ohms, shall not exceed 2.5:1 over the operating frequency range.

## MIL-STD-188-141A

5.4.5.2 Output impedance and power. The receiver output impedance shall be a nominal 600 ohms, balanced with respect to ground, and designed to drive a minimum of six paralleled 600-ohm loads without decrease in output power greater than 2.5 dB relative to a single matched-load output. Electrical symmetry shall be sufficient to suppress longitudinal currents at least 40 dB below reference signal level. The receiver output signal power for operation with a headset or handset shall be adjustable at least over the range from -30 dBm to 0 dBm. For operation with a speaker, the output level shall be adjustable at least over the range from 0 dBm to +30 dBm. As a DO, an additional interface which can accommodate speakers ranging from 4 to 16 ohms impedance should be provided.

5.5 Automatic link establishment (ALE). If ALE is to be implemented, it shall be in accordance with appendix A. The ALE requirements include selective calling and handshake, link quality analysis and channel selection, scanning, and sounding. These requirements are organized in appendix A as follows:

- a. Requirements for ALE implementation are given in sections 10 through 40.
- b. Detailed requirements on ALE waveform, signal structure protocols, and orderwire messages are contained in sections 50 through 90.

## MIL-STD-188-141A

## 6. NOTES.

(This section contains information of a general or explanatory nature that may be helpful, but is not mandatory.)

6.1 Intended use. This standard contains requirements to ensure interoperability of new long-haul and tactical radio equipment in the medium frequency (MF) band and in the high frequency (HF) band.

6.2 Issue of DODISS. When this standard is used in acquisition, the applicable issue of the DODISS must be cited in the solicitation (see 2.1.1 and 2.2).

6.3 Subject term (key word) listing.

Adaptive communications  
 AJ mode  
 ALE  
 ALE mode  
 Automatic link establishment (ALE)  
 Automatic sounding  
 Baseline mode  
 Deep interleaving  
 Forward error correction  
 Golay coding  
 Leading redundant word  
 Lincompex  
 Link protection  
 Link quality analysis (LQA)  
 LQA  
 Orderwire data messages  
 Radio frequency scanning  
 Selective calling  
 Slotted responses  
 Star net and group  
 Triple redundant words  
 Word phase

6.4 International standardization agreements. Certain provisions of this standard in 4.2, 4.4, 5.2, 5.3, and 5.4 are the subject of international standardization agreements, STANAGs 4203 and 5035, and QSTAG 733. When change notice, revision, or cancellation of this standard is proposed that will modify the international agreement concerned, the preparing activity will take appropriate action through international standardization channels, including departmental standardization offices, to change the agreement or make other appropriate accommodations.

6.5 Changes from previous issue. Marginal notations are not used in this revision to identify changes with respect to the previous issue due to the extensiveness of the changes.

## MIL-STD-188-141A

## APPENDIX A

## AUTOMATIC LINK ESTABLISHMENT SYSTEM

## 10. GENERAL.

10.1 Scope. This appendix provides details of the prescribed waveform, signal structures, protocols, and performance for the automatic link establishment (ALE) system.

10.2 Applicability. This appendix is a mandatory part of MIL-STD-188-141A. The functional capability described herein includes automatic signaling, selective calling, automatic answering, and radio frequency (rf) scanning with link quality analysis (LQA). The capability for manual operation of the radio in order to conduct communications with existing, older generation, nonautomated manual radios, shall not be impaired by implementation of these automated features.

## 20. APPLICABLE DOCUMENTS.

20.1 Government documents. The following document forms a part of this appendix to the extent specified:

## STANDARDS

## FEDERAL

## Federal Information Processing Standards

FIPS PUB 1-1

Publication Code: for Information  
Interchange

(Copies of Federal Information Processing Standards (FIPS) are available to Department of Defense activities from the Commanding Officer, Naval Publications and Forms Center, 5801 Tabor Avenue, Philadelphia, PA 19120-5099. Others must request copies of FIPS from the National Technical Information Service, 5285 Port Royal Road, Springfield, VA 22161-2171.)

20.2 Non-Government publications. The following documents form a part of this appendix to the extent specified:

## INTERNATIONAL STANDARDIZATION DOCUMENTS

International Telecommunications Union (ITU),  
Radio RegulationsCCIR  
Recommendation 520Use of High Frequency Ionospheric  
Channel Simulators

(Application for copies should be addressed to the General Secretariat, International Telecommunications Union, Place des Nations, CH-1211 Geneva 20, Switzerland.)

## MIL-STD-188-141A

## APPENDIX A

## International Organization for Standardization (ISO)

International Standard 7498-1984      Open Systems Interconnection (OSI) Reference Model

(Application for copies should be addressed to the Central Secretariat, International Organization for Standardization (ISO) 1, Rue de Varembe, CH-1211, Geneva, 20, Switzerland.)

(Non-Government standards and other publications are normally available from the organizations that prepare or distribute the documents. These documents also may be available in or through libraries or other informational services.)

## 30. DEFINITIONS.

30.1 Standard definitions and acronyms. See Section 3.

30.2 Definitions of timing symbols. The abbreviations and acronyms used for timing symbols are contained in annex A to this appendix.

## 40. GENERAL REQUIREMENTS.

40.1 System test performance. Stations designed to this standard shall demonstrate an overall system performance equal to or exceeding the following requirements. Linking attempts made with a test setup configured as shown on figure A-1, using the specified ALE signal created in accordance with this appendix, shall produce a probability of linking as shown in table A-I.

TABLE A-I. Probability of linking.

Probability of linking	Signal-to-noise ratio (dB)		
	Gaussian noise channel	CCIR good channel	CCIR poor channel
≥ 25%	-2.5	+0.5	+1.0
≥ 50%	-1.5	+2.5	+3.0
≥ 85%	-0.5	+5.5	+6.0
≥ 95%	0.0	+8.5	+11.0

MIL-STD-188-141A

APPENDIX A

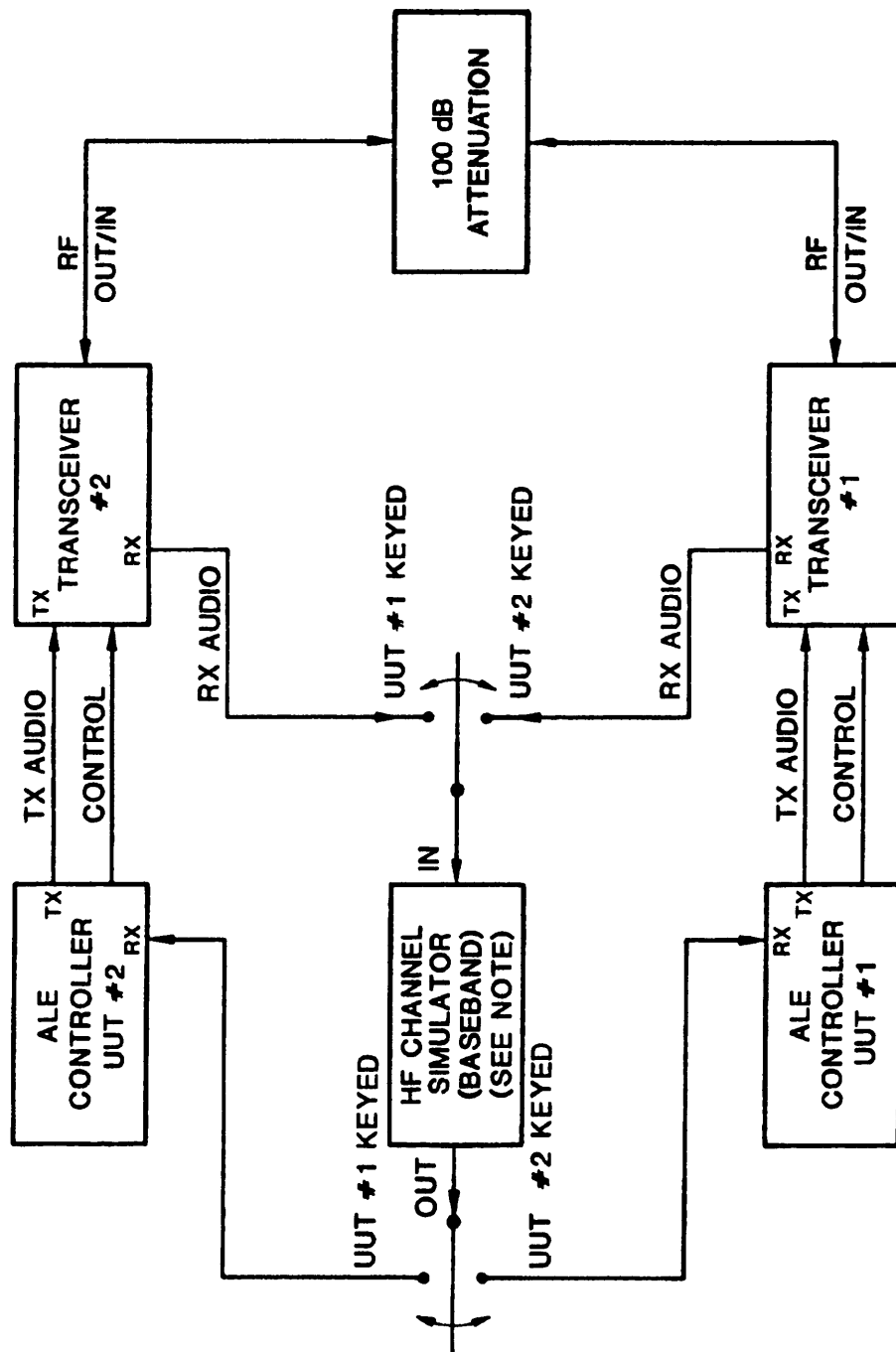

**NOTE:**  
 THE SIMULATOR INCLUDES EITHER INTERNAL OR EXTERNAL CAPABILITY TO ADJUST /  
 MONITOR SIGNAL/NOISE/DOPPLER-OFFSET SETTINGS AND SHALL INCORPORATE  
 APPROPRIATE FILTERING TO LIMIT THE AUDIO PASSBAND TO 300 - 3050 Hz.

FIGURE A-1. System performance measurements test setup.



## MIL-STD-188-141A

## APPENDIX A

The receive audio input to the ALE controller shall be used to simulate the three channel conditions. The CCIR good channel shall be characterized as having 0.5 ms multipath delay and a fading (two sigma) bandwidth of 0.1 Hz. The CCIR poor channel, normally characterized as consisting of a circuit having 2.0 ms multipath delay with a fading (two sigma) bandwidth of 1.0 Hz, shall be modified to have 2.2 ms multipath delay and a fading (two sigma) bandwidth of 1.0 Hz. Doppler shifts of -60 Hz for the CCIR good and poor channels (see table A-I) shall produce no more than a 1.0 dB performance degradation.

NOTE: This modification is necessary due to the fact that the constant 2-ms multipath delay (an unrealistic fixed condition) of the CCIR poor channel results in a constant nulling of certain tones of the ALE tone library. Other tone libraries would also have some particular multipath value which would result in continuous tone cancellation during simulator testing.

Each of the signal-to-noise ratio (SNR) values shall be measured in a nominal 3-kHz bandwidth. Performance tests of this capability shall be conducted in accordance with CCIR Recommendation 520 "Use of High Frequency Ionospheric Channel Simulators", employing the C.C. Watterson Model. This test shall use the individual scanning calling protocol described in 70.4.3. The time for performance of each link attempt shall be measured from the initiation of the calling transmission until the successful establishment of the link. Performance testing shall include the following additional criteria:

- a. The protocol used shall be the individual scanning calling protocol with only TO and THIS IS preambles.
- b. Addresses used shall be alphanumeric, one word (3 characters) in length from the 38-character basic ASCII subset.
- c. Units under test (UUTs) shall be scanning 10 channels at 2 channels per second.
- d. Call initiation shall be performed with the UUT transmitter stopped and tuned to the calling frequency.
- e. Maximum time from call initiation (measured from the start of UUT rf transmission -- not from activation of the ALE protocol) to link establishment shall not exceed 13.000 seconds, plus simulator delay time.

NOTE: Performance at the higher scan rates shall also meet the foregoing requirements and shall produce the same probability of linking as shown in table A-I.

40.2 Channel memory. The equipment shall be capable of storing, retrieving, and employing at least 100 different sets of information concerning channel data to include receive and transmit frequencies with associated mode information. See table A-II. The channel data storage shall be nonvolatile.

MIL-STD-188-141A

APPENDIX A

TABLE A-II. Channel memory example.

Channel	Frequency (MHz)		Mode	TX	RX	T/R	Y	C	S	T	S	C	C	(3) Next Sound	Sound interval	A	P	U	Example comments
	TX	RX																	
C-1	17,777.7	17,777.7	USB	USB	T/R	Y	C	14	min	40	min	1	LO	V					Typical simplex channel, low power, voice, clear
C-2	22,222.2	22,222.2	USB	USB	R	Y	C	--		--		1	LO	V					Same, but receive only at this time
C-3	10,333.0	10,333.0	USB	LSB	T/R	Y	CS	1	min	60	min	2	HI	V					Half-duplex, uses another antenna, high power, clear and secure
C-4	13,111.0	13,999.0	LSB	LSB	T/R	Y	CS	22	min	60	min	1	HI	V,D					Typical voice or data, half-duplex, high power, clear and secure
C-5	9,900.0	9,900.0	USB	LSB	T/R	N	S	--		--		2	LO	D					Typical simplex, non- scan, data only, secure
C-100	0.0	5,000.0	--	AM	R	N	C	--		--		1	-	V,D					Receive only, non- scan, clear

NOTE: 1. (\*) Optional storage of antenna selection(s) "ANT"; power output "PMR"; and usage "USE".  
 2. Y=yes, N=no, C-clear, S-secure, V-voice, D-data.  
 3. "Next sound" indicates time until next sounding on channel and is periodically decremented until "zero" value triggers sounding. It is reset to "sound interval" value by any identifiable transmission (sound or call).  
 4. Values shown for example only.

## MIL-STD-188-141A

## APPENDIX A

The mode information shall include:

- o sounding data
- o group/net association
- o modulation type (associated with frequency)
- o transmit/receive modes
- o filter width (DO)
- o AGC setting (DO)
- o input/output antenna port selection (DO)
- o input/output information port selection (DO)
- o noise blanker setting (DO)
- o transmit power level (DO)
- o traffic or channel use (voice, data, etc.) (DO)
- o security (DO)

Any channel (a) shall be capable of being recalled manually or under the direction of any associated automated controller, and (b) shall be capable of having its information altered after recall without affecting the original stored information settings.

40.3 Scanning. The radio shall be capable of repeatedly scanning selected channels stored in memory (in the radio or controller) under either manual control or under the direction of any associated automated controller. The scanned channels should be selectable by groups (such as 10 groups of 10 channels) and also individually within the groups, to enable flexibility in channel and network scan management. The design shall incorporate selectable scan rates of 2 channels per second (chps) and 5 chps (DO: 2, 5, and 10 chps). Performance shall meet the requirements of 40.1. The radio shall stop scanning and wait on the most recent channel during the advent of any of the following selectable events:

- o Automatic controller input of stop scan (the normal mode of operation)
- o Manual input of stop scan
- o Activation of push-to-talk (PTT) line (DO)
- o Activation of external stop-scan line (DO)

40.4 Self address memory. The radio shall be capable of storing, retrieving, and employing at least twenty different sets of information concerning self addressing. The self address information storage shall be nonvolatile. These sets of information include self (its own personal) address(es), valid channels which are associated for use, and net addressing. Net addressing information shall include (for each "net member" self address, as necessary) the net address and the present slot wait time (in multiples of  $T_w$ ). See table A-III. The slot wait time values are  $T_{swt}(SN)$  from the formula in 70.6.2. Stations called by their net call address shall respond with their associated self (net member) address with the specified delay ( $T_{swt}(SN)$ ). For example, the call is "GUY", thus the response is "BEN". Stations called individually by one of their self addresses (even if a net member address) shall respond immediately, and with that address, as specified in the individual scanning calling protocol. Stations called by one of their self addresses (even if a net member

## MIL-STD-188-141A

## APPENDIX A

TABLE A-III. Self address memory example.

Index	Self (or net member) address	Net address	Tswt(SN)= slot wait time (Tw)	(4) Valid channels	Example comments
SA1	SAM	--	--	All	simple individual address, 1-word, all channels
SA2	BOBBIE	--	--	C1,2,3	simple individual address, 2-word, limited channels
SA3	JIM	--	--	C7	simple individual address, 1-word, single channel
SA4	BEN	GUY	14	All	net and individual addresses, 1-word, all channels, preset slot unit time (slot 1)
SA5	CLAUDETTE	GAL	80	C3-C7	net and 3-word individual addresses, limited channels, preset slot wait-time (slot 4)
SA6	JOE	PEOPLE	17	C1-C9	2-word net and 1-word individual addresses, limited channels preset slot wait-time
.	.	.	.	.	
:	:	:	:	:	
.	.	.	.	.	
SA20	--	PARTY	--	C5-C12	2-word net only address, therefore receive only if called

## NOTES:

1. The self address number "SA#" index is included for clarity. Indexes may be useful for efficient memory management.
2. If a net address is associated with a self address, the self address should be referred to as a "net member" address.
3. Addresses and values shown for example only.
4. Valid channels are the channels on which this address is planned, or permitted, to be used.

## MIL-STD-188-141A

## APPENDIX A

address) within a group call shall respond in the derived slot, and with that address, as specified in the star group scanning calling protocol. If a station is called by one of its net addresses and has no associated net member address, it shall pause and listen to the entire transmission but shall not respond (unless subsequently called separately with an available self or net member address).

40.5 Other address memory. The radio shall be capable of storing, retrieving, and employing at least 100 different sets of information concerning the addresses of other stations and nets. The other address information storage shall be nonvolatile. Individual addresses shall be stored individually, and shall be associated with a specific wait for reply time (Twr) if not the default value. Net information shall include own net and net member associations, relative slot sequences, and own net wait for reply times (Twrn) for use when calling. See table A-IV.

As a DO, any excess capacity which is not programmed with preplanned other address information should be automatically filled with any addresses heard on any of the scanned or monitored channels. When the excess capacity is filled, it should be kept current by replacing the oldest heard addresses with the latest ones heard. This fortuitous information should be used for calling initiation to those stations (if needed), and for activity evaluation.

40.6 Connectivity and LQA memory. The radio shall be capable of storing, retrieving, and employing at least 4000 (DO: 10,000) sets of connectivity and LQA information associated with the channels and the other addresses in an LQA memory. The connectivity and LQA information storage shall be nonvolatile. The information in each address/channel "cell" shall include as a minimum, the bilateral (two-way) BER values of (a) the signals received at the station, and (b) the station's signals received at, and reported by, the other station. It shall also include either an indicator of the age of the information (for discounting old data), or an algorithm for automatically reducing the weight of data with time, to compensate for changing propagation conditions. As a DO, the cells of the LQA memory should also include bilateral SINAD values and MP information derived by suitably equipped units. The information within the LQA memory shall be used to select channels and manage networks as stated in this document. See figure A-2.

## MIL-STD-188-141A

## APPENDIX A

TABLE A-IV. Other address memory example.

Other or net address	Individual (net member) address and slots				Valid channels	(Net) wait for reply time (Tw)	Example comments
	slot 1	slot 2	slot 3	slot 4			
IRA	NA	NA	NA	NA	A11	Twr	Individual address
BAB	NA	NA	NA	NA	C1-C12	Twr	Same
GUY	BEN*	DOC	DAD	ABE	A11	Twrn(5)	own net 4 members
GAL	AMY	LIZ	JANE	CLAUDETTE*	C3-C7	Twrn(5)	own net 4 members
PEOPLE	JOE*	BILL	SUE	NA	C1-C9	Twrn(4)	own net 3 members
PARTY	* *	NA	NA	NA	C5-C12	0	one way broadcast net, no responses
CLUSTER	ALFA	BRAVO	CHARLIE	NA	C2-C10	Twrn(4)	other net 3 members

## NOTES:

1. Total number of addresses shall be at least 100.
2. \* Indicates a self (net member) address in this example for the assigned slot; i.e., station is a member of listed net.
3. \*\* Indicates that the station is a member of the listed net, but does not respond when called.
4. Excess capacity should (DO) be filled with any other addresses heard (DO).
5. Addresses for example only.

APPENDIX A

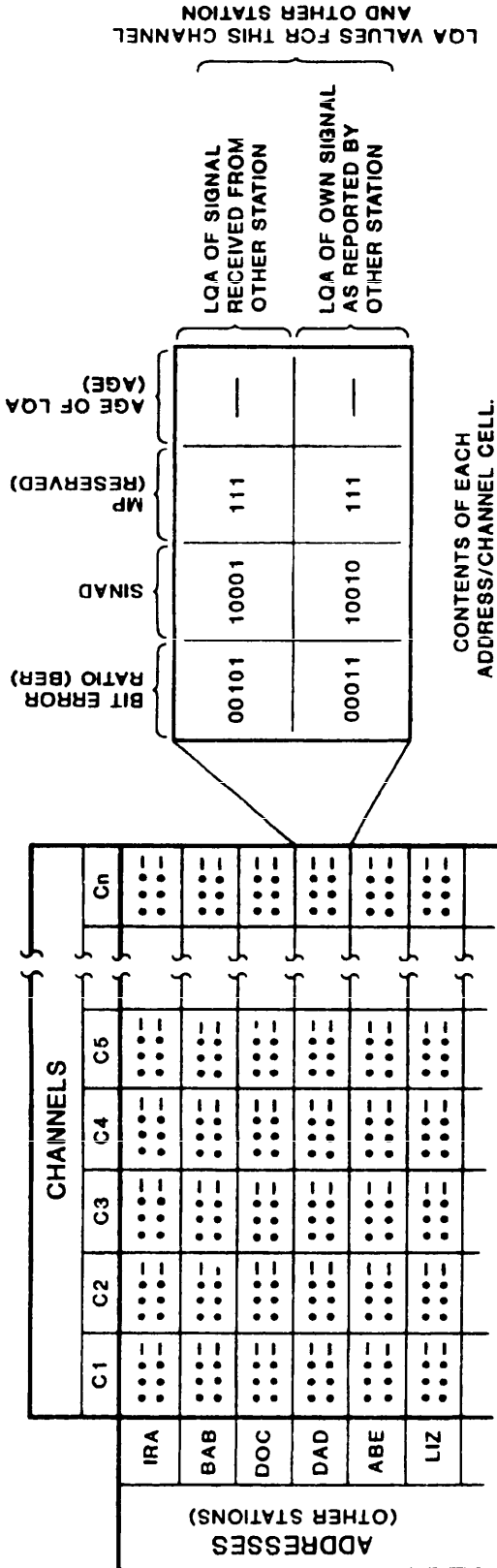

NOTES:

1. MEMORY STRUCTURE SHOWN IN MATRIX EXAMPLE FOR CLARITY, AND MORE EFFICIENT MEMORY MANAGEMENT TECHNIQUES ARE ENCOURAGED, BECAUSE NOT ALL CHANNELS WILL BE USED BY ALL ADDRESSES (IN MANY SITUATIONS).
2. EXCESS MEMORY CAPACITY SHOULD (DO) BE USED TO RETAIN THE LATEST OTHER STATIONS HEARD (THAT ARE NOT IN THE PREPROGRAMMED SET) AND THEIR LQA CHARACTERISTICS ON THE CHANNELS ON WHICH THE STATIONS WERE HEARD.
3. VALUES FOR EXAMPLE ONLY.
4. MULTIPATH (MP) TRIBITS RESERVED IN LQA WORD TRANSMISSION (BITS SHALL BE SET TO '111').

FIGURE A-2. Connectivity and LQA memory example.

## MIL-STD-188-141A

## APPENDIX A

## 50. WAVEFORM.

50.1 Introduction. The ALE waveform is designed to pass through the audio passband of standard SSB radio equipment. This waveform shall provide for a robust, low-speed, digital modem capability used for multiple purposes to include selective calling and data transmission. This section defines the waveform including the tones, their meanings, the timing and rates, and their accuracy.

50.2 Tones. The waveform shall be an 8-ary frequency shift-keying (FSK) modulation with eight orthogonal tones, one tone (or symbol) at a time. Each tone shall represent three bits of data as follows (least significant bit (LSB) to the right):

o	750 Hz	000
o	1000 Hz	001
o	1250 Hz	011
o	1500 Hz	010
o	1750 Hz	110
o	2000 Hz	111
o	2250 Hz	101
o	2500 Hz	100

The transmitted bits shall be the encoded and interleaved data bits constituting a word, as described in 60.2 and 60.3. The transitions between tones shall be phase continuous and should be at waveform maxima or minima (slope zero).

50.3 Timing. The tones shall be transmitted at a rate of 125 tones (symbols) per second, with a resultant period of 8 milliseconds (ms) per tone. Figure A-3 shows the frequency and time relationships. The transmitted bit rate shall be 375 bps. The transitions between adjacent redundant (tripled) transmitted words shall coincide with the transitions between tones, resulting in an integral 49 symbols (or tones) per redundant (tripled) word. The resultant single word period ( $T_w$ ) shall be 130.66... ms (or 16.33... symbols), and the triple word (basic redundant format) period ( $3T_w$ ) shall be 392 ms.

50.4 Accuracy. At baseband audio, the generated tones shall be within  $\pm 1.0$  Hz. At rf, all transmitted tones shall be within a range of 1.0 dB in amplitude. Transmitted symbol timing, and therefore the bit and word rates, shall be within ten parts per million.



MIL-STD-188-141A

APPENDIX A

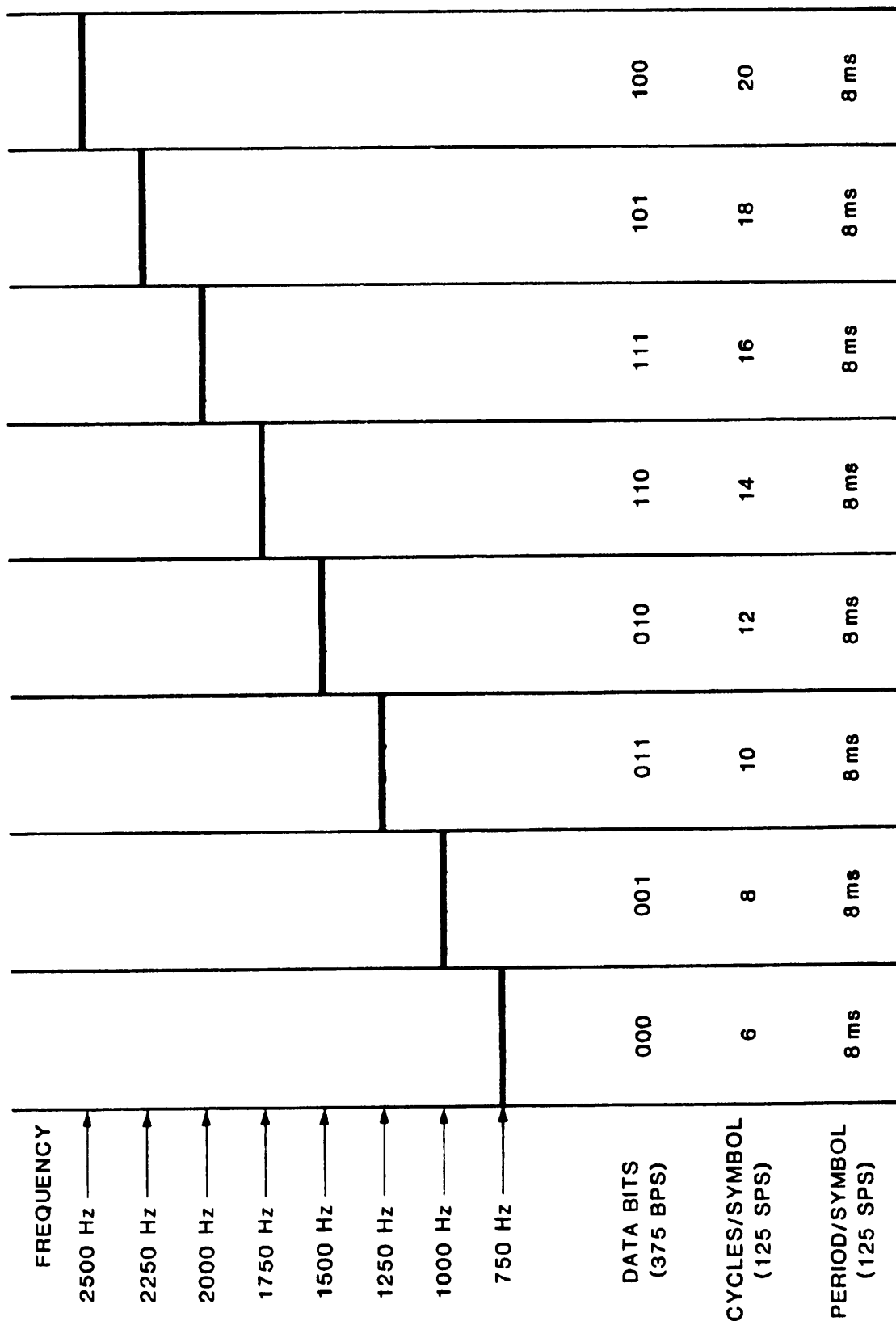

**NOTE:**  
SYMBOL TRANSITIONS SHALL BE PHASE CONTINUOUS.

FIGURE A-3. ALE symbol library.

## MIL-STD-188-141A

## APPENDIX A

## 60. SIGNAL STRUCTURE.

60.1 Introduction. This section provides definition of the ALE signal structure. Included are: bit and word format and structure, coding, forward error correction (FEC), framing, and synchronization. Also described in this section are: addressing, signal quality analysis, and the functions of the standard word preambles associated with the signal structure.

60.2 Word format. The basic ALE word shall consist of 24 bits of information, designated W1 (most significant bit (MSB)) through W24 (LSB). The bits shall be designated as shown on figure A-4.

60.2.1 Structure. The word shall be divided into four parts: a 3-bit preamble and three individual 7-bit characters. The MSB for all parts, and the word, is to the left on figure A-4 and is sent earliest. Before transmission, the word shall be divided into two 12-bit halves (Golay codec A and B) for FEC encoding as described in 60.3.

60.2.2 Word types. The leading three bits W1 through W3 are designated preamble bits P3 through P1, respectively. These preamble bits shall be used to identify one of eight possible word types.

60.2.3 Preambles. The word types (and preambles) shall be as shown in table A-V and as described herein.

60.2.3.1 THRU. The THRU word (001) shall be used in the scanning call section of the calling cycle only with group call protocols. The THRU word shall be used alternately with REPEAT, as routing designators, to indicate the address first word of stations that are to be directly called. Each address first word shall be limited to one basic address word (3 characters) in length. A maximum of five different address first words shall be permitted in a group call. The sequence shall only be alternations of THRU, REPEAT. The THRU shall not be used for extended addresses, as it will not be used within the leading call section of the calling cycle. When the leading call starts in the group call, the entire group of called stations shall be called with their whole addresses, which shall be sent using the TO preambles and structures, as described in 60.2.3.2.

NOTE: The THRU word is also reserved for future implementation of indirect and relay protocols, in which cases it may be used elsewhere in the ALE frame and with whole addresses and other information. Stations designed in compliance with this nonrelay standard should ignore calls to them which employ their address in a THRU word in other than the scanning call.

60.2.3.2 TO. The TO word (010) shall be used as a routing designator which shall indicate the address of the present destination station(s) which is (are) to directly receive the call. TO shall be used in the individual call protocols for single stations and in the net call protocols for multiple net-member stations which are called using a single net address. The TO word itself shall contain an address, one basic address word (3 characters) in length. For extended addresses, the additional address words (and characters) shall be contained in alternating DATA and REPEAT words, which

MIL-STD-188-141A

APPENDIX A

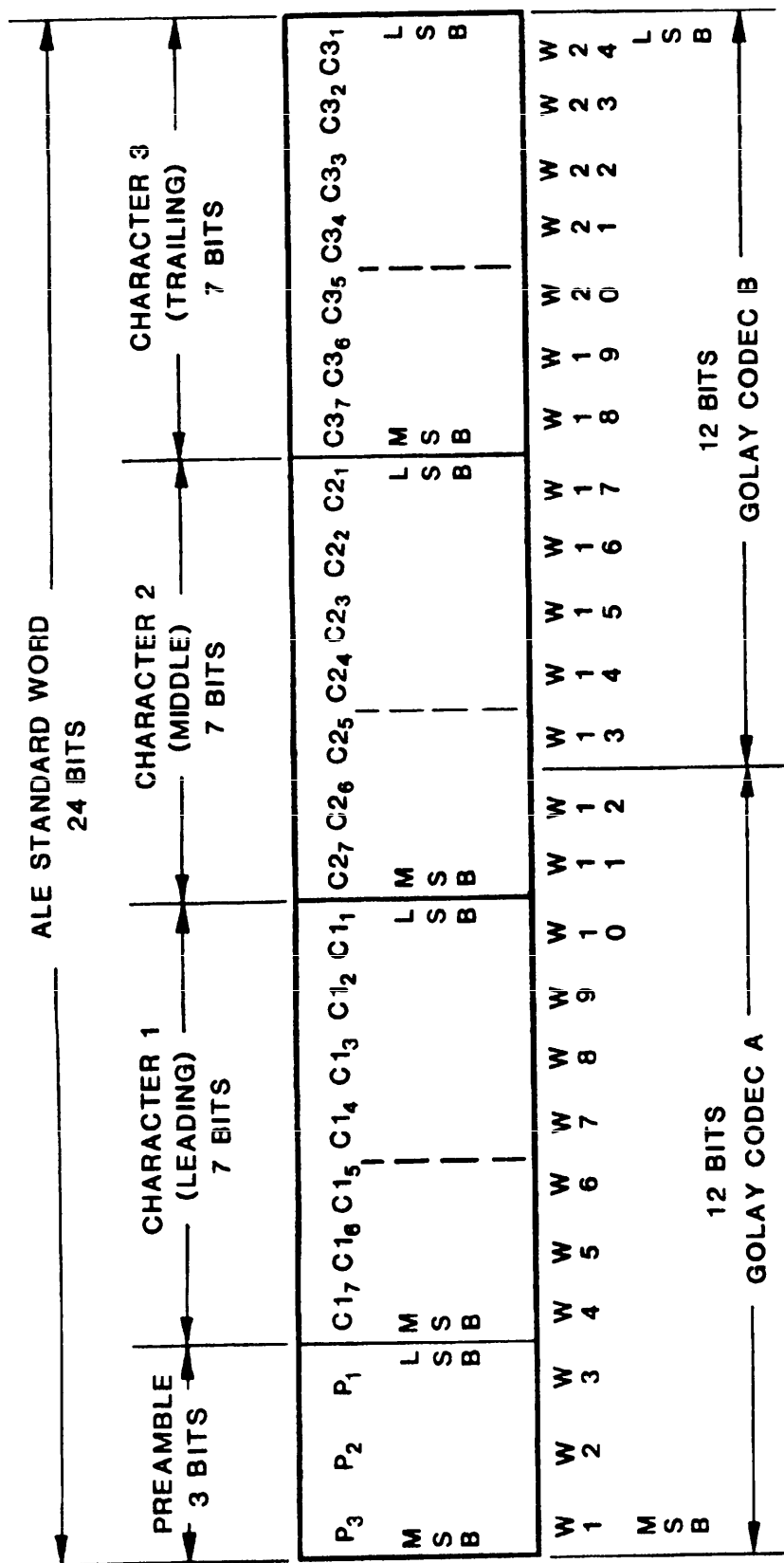

**NOTE:**  
THREE 7-BIT ASCII CHARACTERS PER WORD IN DATA FIELD (W<sub>4</sub>-W<sub>10</sub>, W<sub>11</sub>-W<sub>17</sub>, W<sub>18</sub>-W<sub>24</sub>).  
OPTIONAL 21-BIT UNFORMATTED DATA FIELD (W<sub>4</sub>-W<sub>24</sub>). MSB (W<sub>1</sub>) TRANSMITTED FIRST.

FIGURE A-4. ALE basic word structure.

## MIL-STD-188-141A

## APPENDIX A

TABLE A-V. ALE word types (preambles).

Word type	Code bits	Functions	Significance
<u>THRU</u>	001	multiple (and indirect) routing	present multiple direct destinations for group calls (and future indirect relays, reserved)
<u>TO</u>	010	direct routing	present direct destination for individual and net calls
<u>COMMAND</u>	110	orderwire control and status	ALE system-wide station (and operator) orderwire for coordination, control, status, and special functions
<u>FROM</u>	100	identification (and indirect routing)	identification of present transmitter without termination (and past originator and relayers, reserved)
<u>THIS IS</u>	101	terminator and identification, continuing	identification of present transmitter, signal terminations, protocol continuation
<u>THIS WAS</u>	011	terminator and identification, quitting	identification of present transmitter, signal and protocol termination
<u>DATA</u>	000	extension and information	extension of data field of the previous ALE word, or information defined by the previous <u>COMMAND</u>
<u>REPEAT</u>	111	duplication and information	duplication of the previous preamble, with new data field, or information defined by the previous <u>COMMAND</u>

```

      111
     /  |  \
    P3  P2  P1
  MSB  W2  LSB
  W1   W2  W3

```

## MIL-STD-188-141A

## APPENDIX A

shall immediately follow. The sequence shall be TO, DATA, REPEAT, DATA, and REPEAT, and shall be only long enough to contain the address, up to a maximum capacity of five address first words (15 characters). The entire address (and the required portion of the TO, DATA, REPEAT, DATA, REPEAT, sequence, as necessary) shall be used in the leading call section of the ALE calling cycle. However, in the immediately preceding scanning call section of the calling cycle, only the first word of the destination address (and using only the TO) shall be used, to speed scanning and linking.

60.2.3.3 COMMAND. The COMMAND word (110) is a special orderwire designator which shall be used for system-wide coordination, command, control, status, information, interoperation, and other special purposes. COMMAND shall be used in any combination between ALE stations and operators. COMMAND is an optional designator which is used only within the message section of the ALE frame, and it shall have (at some time in the frame) a preceding call and a following conclusion, to ensure designation of the intended receivers and identification of the sender. The first COMMAND terminates the calling cycle and indicates the start of the message section of the ALE frame. The orderwire functions are directed with the COMMAND itself, or when combined with the REPEAT and DATA words. See section 80 for orderwire messages and functions.

60.2.3.4 FROM. The FROM word (100) is an optional designator which shall be used to identify the transmitting station without using an ALE frame termination, such as THIS IS or THIS WAS. It shall contain the whole address of the transmitting station, using the FROM, and if required, the DATA and REPEAT words, exactly as described in the TO address structure in 60.2.3.2. It should be used only once in each ALE frame, and it shall be used only immediately preceding a COMMAND in the message section. Under direction of the operator or controller, it should be used to provide a "quick ID" of the transmitting station when the normal conclusion may be delayed, such as when a long message section is to be used in an ALE frame.

NOTE: The FROM word is also reserved for future implementation of indirect and relay protocols, in which cases it may be used elsewhere in the ALE frame and with multiple addresses and other information. Stations designed in compliance with this nonrelay standard should ignore sections of calls to them which employ FROM words in any other sequence than immediately before the COMMAND word.

60.2.3.5 THIS IS. The THIS IS word (101) shall be used as a routing designator which shall indicate the address of the present calling (or sounding) station which is directly transmitting the call (or sound). Except for the use of THIS WAS, THIS IS shall be used in all ALE protocols to terminate the ALE frame and transmission. It shall indicate the continuation of the protocol or handshake, and shall direct, request, or invite (depending on the specific protocol) responses or acknowledgements from other called or receiving stations. The THIS IS shall be used to designate the call acceptance sound. The THIS IS word itself shall contain at least the first

## MIL-STD-188-141A

## APPENDIX A

word of the calling station's address, which shall be up to one basic address word (3 characters) in length. For extended addresses, the additional address words (and characters) shall be contained in alternating DATA and REPEAT words which shall immediately follow, exactly as described for whole addresses using the TO word and sequence. The entire address (and the required portion of the THIS IS, DATA, REPEAT, DATA, REPEAT sequence, as necessary) shall be used only in the conclusion section of the ALE frame (or shall constitute an entire sound). THIS WAS shall not be used in the same frame as THIS IS, as they are mutually exclusive.

60.2.3.6 THIS WAS. The THIS WAS word (011) shall be used as a routing designator exactly as the THIS IS, with the following variations. It shall indicate the termination of the ALE protocol or handshake, and shall reject, discourage, or not invite (depending on the specific protocol) responses or acknowledgements from other called or receiving stations. The THIS WAS shall be used to designate the call rejection sound. THIS IS shall not be used in the same frame as THIS WAS, as they are mutually exclusive.

60.2.3.7 DATA. The DATA word (000) is a special designator which shall be used to extend the data field of any previous word type (except DATA itself) or to convey information in a message. When used with the routing designators TO, FROM, THIS IS, or THIS WAS, DATA shall perform address extension from the basic three characters to six, nine, or more (in multiples of three) when alternated with REPEAT words. The selected limit for address extension is a total of fifteen characters. When used with COMMAND, its function is predefined as specified in section 80.

60.2.3.8 REPEAT. The REPEAT word (111) is a special designator which shall be used to duplicate any previous preamble function or word meaning while changing the data field contents (bits W4 through W24). See table A-V. Any change of words or data field bits requires a change of preamble bits (P<sub>3</sub> through P<sub>1</sub>) to preclude uncertainty and errors. If a word is to change, even if the data field is identical to that in the previous word, the preamble shall be changed, thereby clearly designating a word change. When used with the routing designator TO, REPEAT performs address expansion, which enables more than one address to be specified. See 70.6. See 60.2.3.1 for use with THRU. With DATA, REPEAT may be used to extend and expand address, message, command, and status fields. REPEAT shall be used to perform these functions, and it may directly follow any other word type except for itself, and except for THIS IS or THIS WAS, as there cannot be more than one transmitter for a specific call at a given time.

60.2.3.9 Valid sequences. The eight ALE word types which have been described shall be used to construct calls and messages only as permitted on figure A-5. The size and duration of ALE calls, and their parts, shall be limited as described in table A-VI.

#### 60.2.4 Characters.

60.2.4.1 General. The ALE system provides and supports three compatible sets of characters, all of which are based on Federal Information Processing Standard (FIPS) Pub 1-1.

MIL-STD-188-141A

APPENDIX A

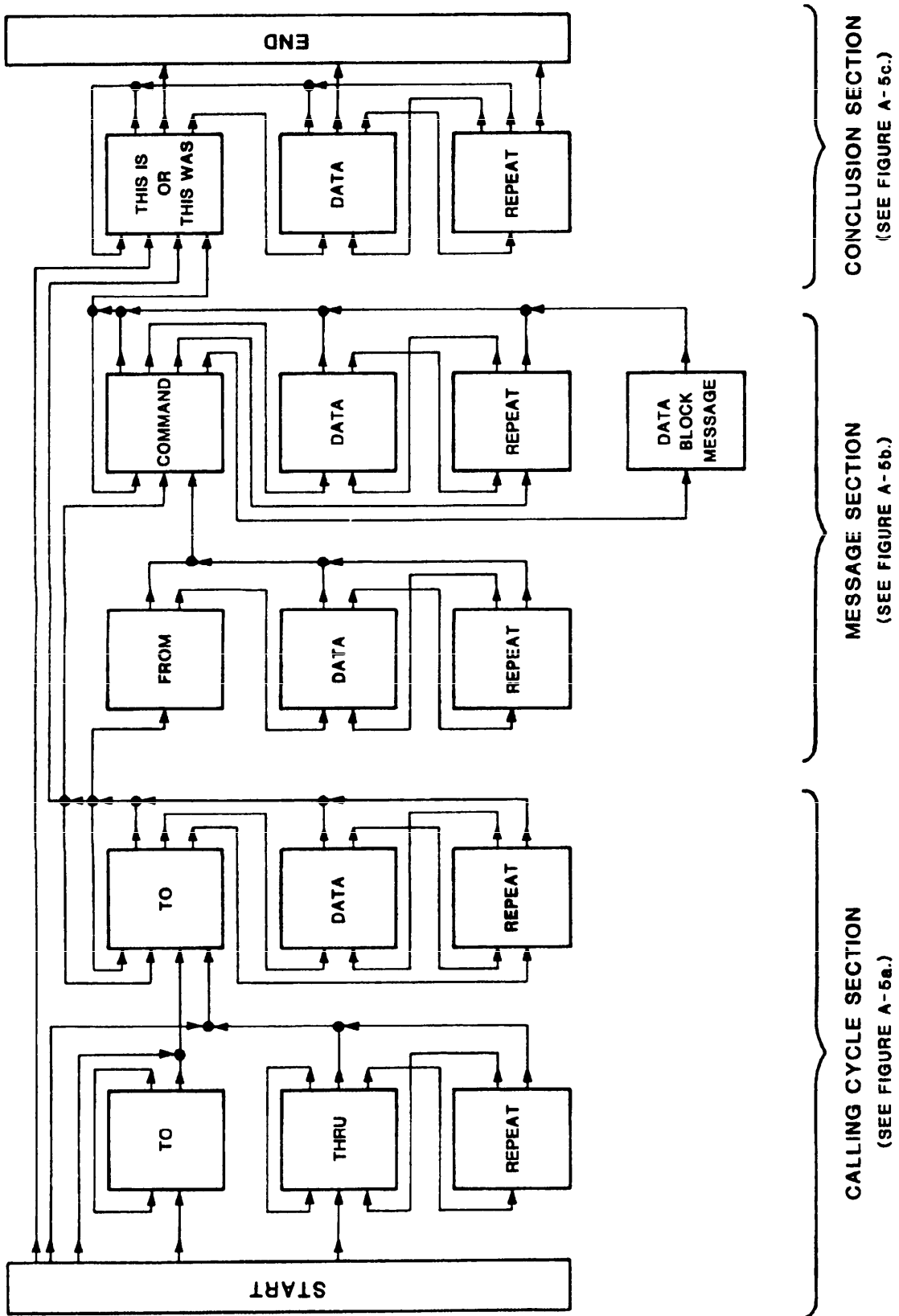

FIGURE A-5. Valid word sequences.

MIL-STD-188-141A

APPENDIX A

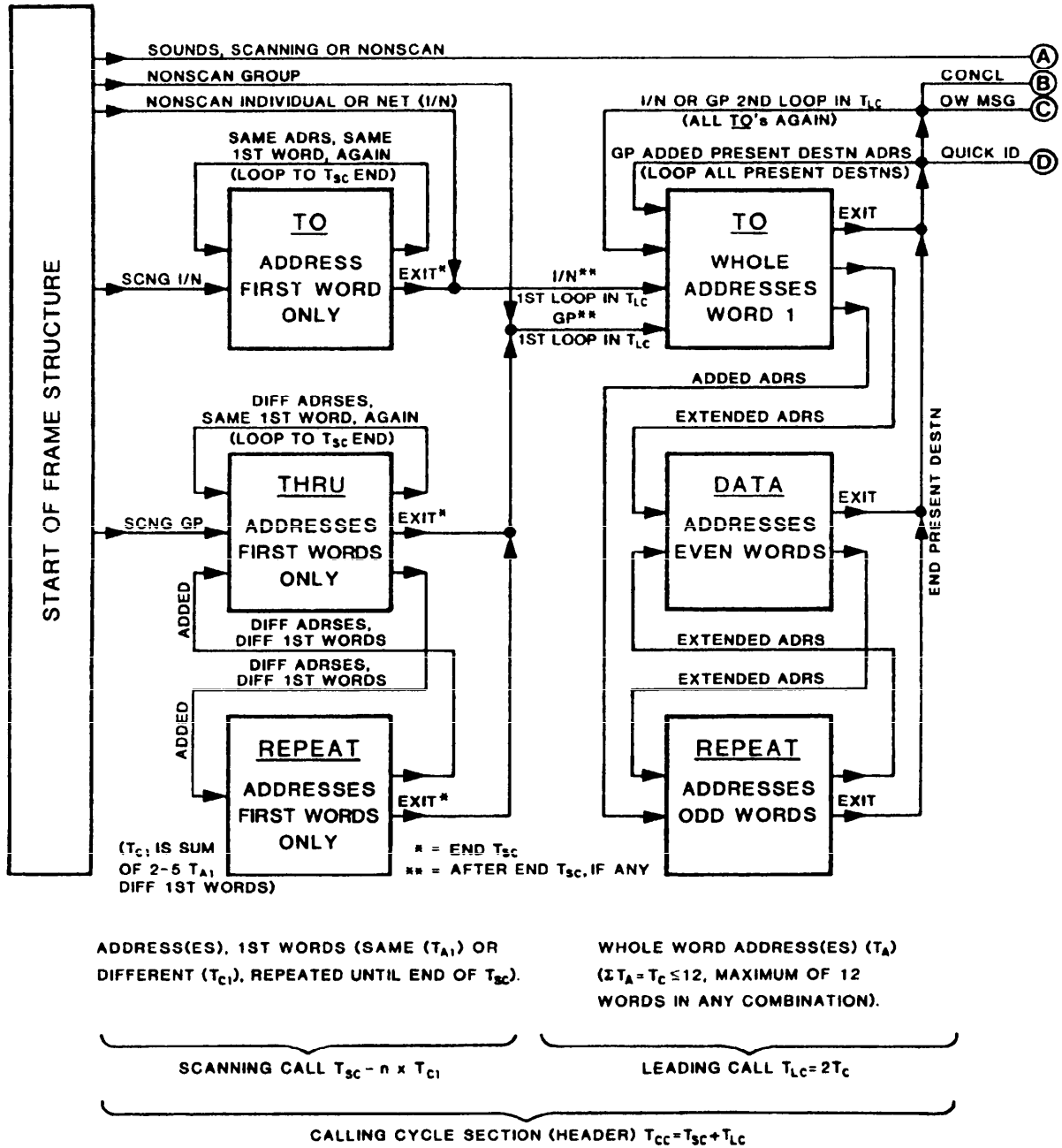

FIGURE A-5a. Valid word sequences -- Continued: (calling cycle section).



MIL-STD-188-141A

APPENDIX A

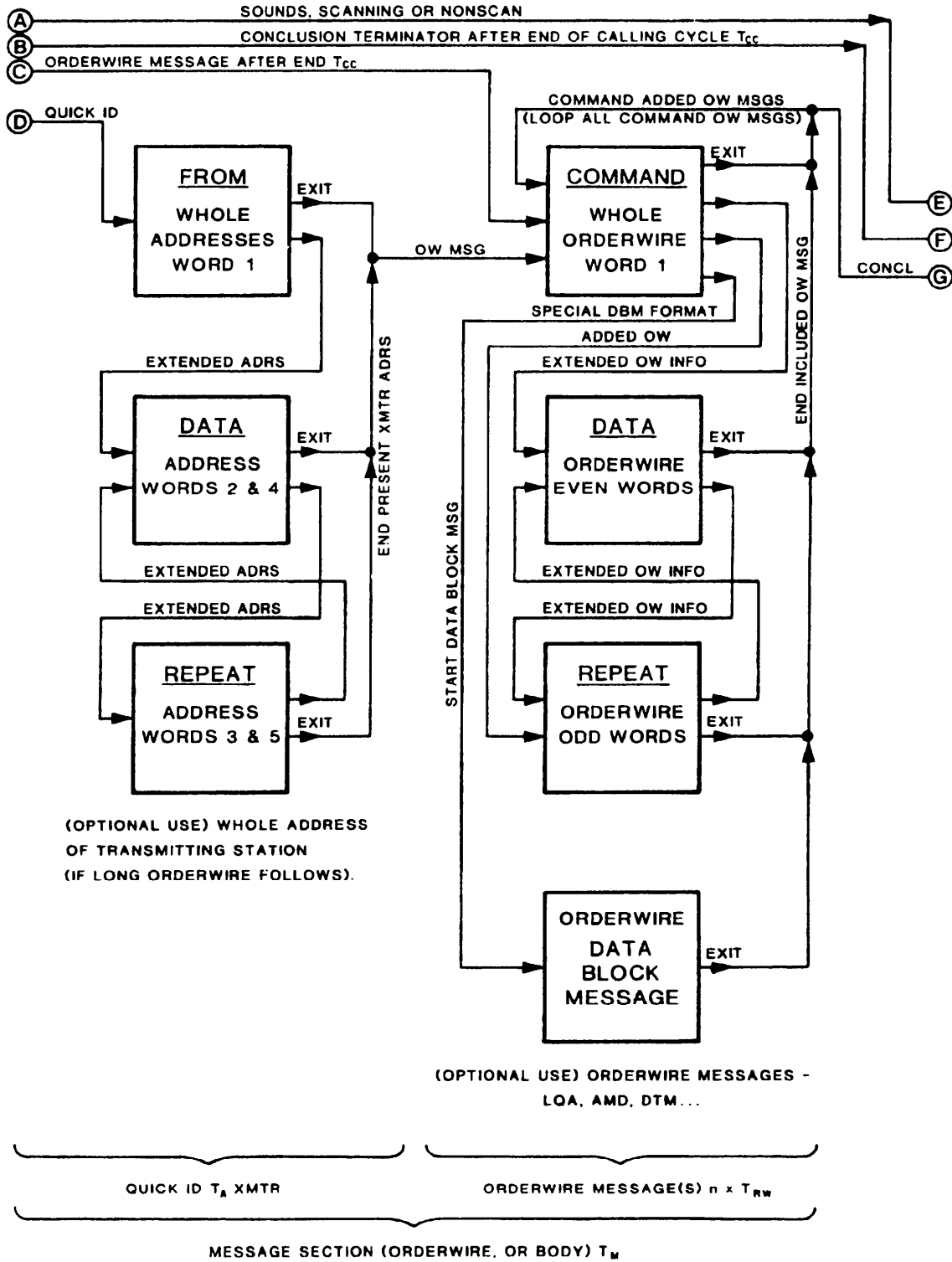

FIGURE A-5b. Valid word sequences -- Continued: (message section).

MIL-STD-188-141A

APPENDIX A

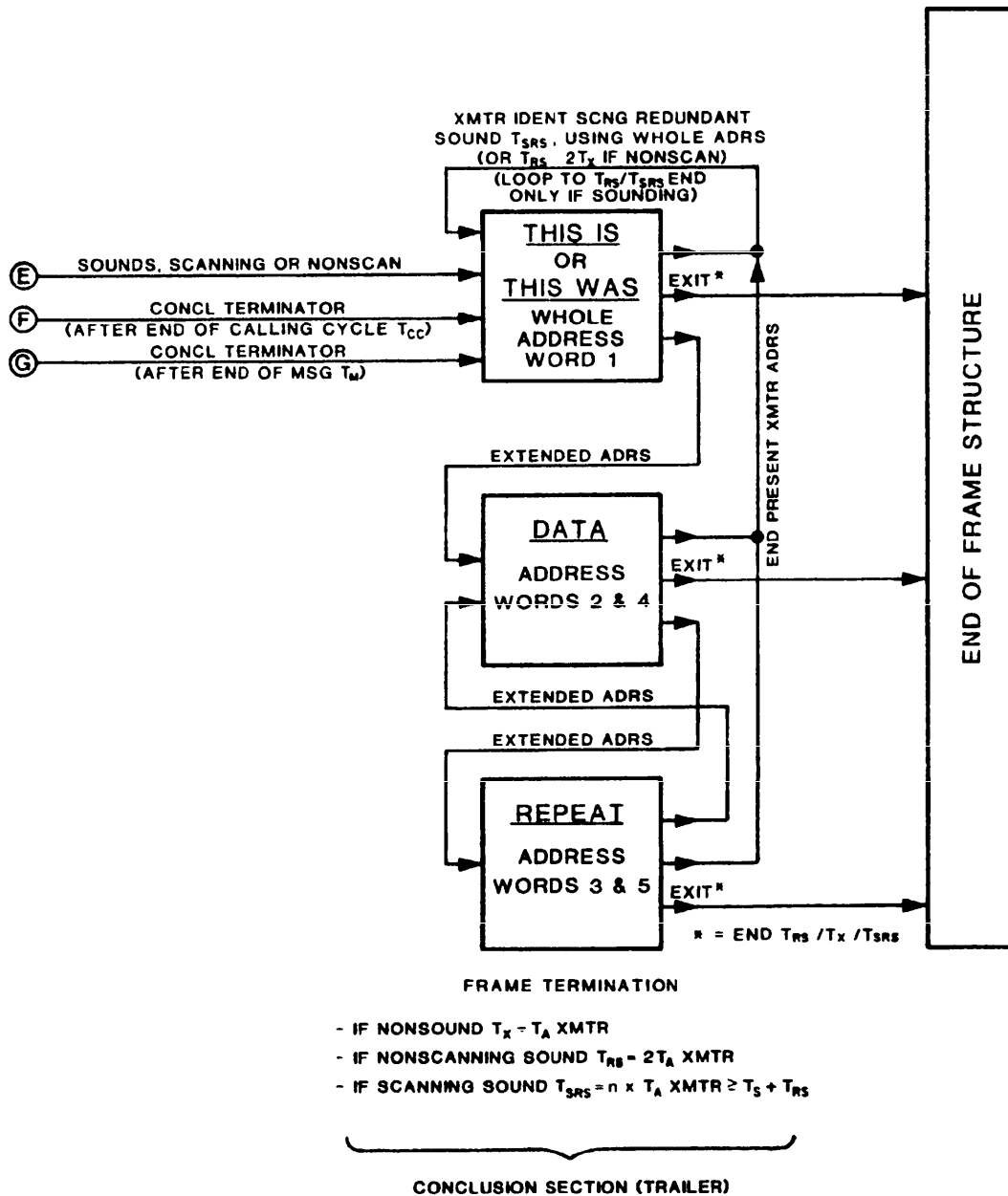

FIGURE A-5c. Valid word sequences -- Continued:  
(conclusion section).

## MIL-STD-188-141A

## APPENDIX A

TABLE A-VI. Limits to calls.

Calls	Limit
Address size (5 words) (Ta max)	1960 ms
Call time (12 words) (Tc max)	4704 ms
Scan period (Ts max)	50 s
Message section time, AMD (90 characters), or DTM (84 characters, unless modified by <u>COMMAND</u> )	11.76 s
Message section time, DTM (1053 characters) (Tm max DTM)	2.29 min (entire data block)
Message section time, DBM (37545 characters) (Tm max DBM)	23.36 min (entire deeply interleaved block)

60.2.4.2 Basic 38 ASCII subset. The basic 38 ASCII subset shall include all capital alphabets (A-Z) and all digits (0-9), plus designated utility and wildcard symbols "@" and "?", as shown on figure A-6. The basic 38 subset shall be used for all basic addressing functions as described in 60.5. To be a valid basic address, the word shall contain a routing preamble (such as TO...), plus three alphanumeric characters (A-Z, 0-9) from the basic 38 subset in any combination. In addition, the "@" and "?" symbols shall be used for special functions only as described in 60.5.4. Digital discrimination of the basic 38 subset shall not be limited to examination of only the three MSBs (b7 through b5), as a total of 48 digital bit combinations would be possible (including ten invalid symbols which would be improperly accepted).

60.2.4.3 Expanded 64 ASCII subset. The expanded 64 ASCII subset shall include all capital alphabets (A-Z), all digits (0-9), the utility symbols "@" and "?", plus 26 other commonly used symbols. See figure A-7. The expanded 64 subset shall be used for all basic orderwire message functions, as described in section 80, plus special functions as may be standardized. For orderwire message use, the subset members shall be enclosed within a sequence of DATA (and REPEAT) words and shall be preceded by an associated COMMAND (such as data text message). This COMMAND designates the usage of the information which follows, and shall also be preceded by a valid and appropriate calling cycle using the basic 38 subset addressing. Digital discrimination of the expanded 64 subset may be accomplished by examination of the two MSBs (b7 and b6), as all of the members within the "01" and "10" MSBs are acceptable. No parity bits are transmitted, because the integrity of the information is protected by the basic ALE FEC and redundancy and may be ensured by optional use of the COMMAND CRC (cyclic redundancy check), as described in section 80.

MIL-STD-188-141A

APPENDIX A

				0 0 0 1					0 1 0					1 0 0					1 1 0					1 1 1																																																																								
				0	1	0	1	0	0	1	0	0	1	1	0	1	0	0	1	1	0	1	0	0	1																																																																							
b <sub>7</sub> ↑	b <sub>6</sub> ↑	b <sub>5</sub> ↑	b <sub>4</sub> ↑	b <sub>3</sub> ↑	b <sub>2</sub> ↑	b <sub>1</sub> ↑	COLUMNS					COLUMNS					COLUMNS					COLUMNS																																																																										
							0					1					2					3					4					5					6					7																																																						
NUJL							DLE					SP										@					P					Y					p																																																											
SOH							DC1					!					"					#					\$					%					&					'					(					)					*					+					,					.					-					.					/					?				
STX							DC2					"					#					\$					%					&					'					(					)					*					+					,					.					-					.					/					?									
ETX							DC3					#					\$					%					&					'					(					)					*					+					,					.					-					.					/					?														
EOT							DC4					\$					%					&					'					(					)					*					+					,					.					-					.					/					?																			
ENG							NAK					%					&					'					(					)					*					+					,					.					-					.					/					?																								
ACK							SYN					&					'					(					)					*					+					,					.					-					.					/					?																													
BEL							ETB					'					(					)					*					+					,					.					-					.					/					?																																		
BS							CAN					(					)					*					+					,					.					-					.					/					?																																							
HT							EM					)					*					+					,					.					-					.					/					?																																												
LF							SUB					*					+					,					.					-					.					/					?																																																	
VT							ESC					+					,					.					-					.					/					?																																																						
FF							FS					,					.					-					.					/					?																																																											
CR							GS					-					.					/					?																																																																					
SO							RS					.					/					?																																																																										
SI							US					/					?																																																																															
DEL							DEL					DEL					DEL					DEL					DEL					DEL					DEL																																																											

FIGURE A-6. Basic 38 ASCII subset.

## MIL-STD-188-141A

## APPENDIX A

BITS					0 0 0 0 1					0 1 0 1 1					1 0 0 0 1					1 1 0 1 1				
b <sub>7</sub>	b <sub>6</sub>	b <sub>5</sub>	b <sub>4</sub>	b <sub>3</sub>	b <sub>2</sub>	b <sub>1</sub>	COLUMN	0	1	2	3	4	5	6	7	8	9	10	11	12	13	14	15	
							ROW	0	1	2	3	4	5	6	7	8	9	10	11	12	13	14	15	
0	0	0	0	0	0	0	0	0	0	0	0	0	0	0	0	0	0	0	0	0	0	0	0	
0	0	0	0	0	0	0	0	0	1	0	0	0	0	0	0	0	0	0	0	0	0	0	0	
0	0	0	0	1	0	0	0	1	0	0	0	0	0	0	0	0	0	0	0	0	0	0	0	
0	0	1	0	0	0	0	0	1	0	0	0	0	0	0	0	0	0	0	0	0	0	0	0	
0	0	1	1	0	0	0	0	1	0	0	0	0	0	0	0	0	0	0	0	0	0	0	0	
0	1	0	0	0	0	0	0	1	0	0	0	0	0	0	0	0	0	0	0	0	0	0	0	
0	1	0	1	0	0	0	0	1	0	0	0	0	0	0	0	0	0	0	0	0	0	0	0	
0	1	1	0	0	0	0	0	1	0	0	0	0	0	0	0	0	0	0	0	0	0	0	0	
0	1	1	1	0	0	0	0	1	0	0	0	0	0	0	0	0	0	0	0	0	0	0	0	
1	0	0	0	0	0	0	1	0	0	0	0	0	0	0	0	0	0	0	0	0	0	0	0	
1	0	0	1	0	0	0	1	0	0	0	0	0	0	0	0	0	0	0	0	0	0	0	0	
1	0	1	0	0	0	0	1	0	1	0	0	0	0	0	0	0	0	0	0	0	0	0	0	
1	0	1	1	0	0	0	1	0	1	0	0	0	0	0	0	0	0	0	0	0	0	0	0	
1	1	0	0	0	0	0	1	1	0	0	0	0	0	0	0	0	0	0	0	0	0	0	0	
1	1	0	1	0	0	0	1	1	0	1	0	0	0	0	0	0	0	0	0	0	0	0	0	
1	1	1	0	0	0	0	1	1	1	0	0	0	0	0	0	0	0	0	0	0	0	0	0	
1	1	1	1	0	0	0	1	1	1	1	0	0	0	0	0	0	0	0	0	0	0	0	0	

FIGURE A-7. Expanded 64 ASCII subset.

## MIL-STD-188-141A

## APPENDIX A

60.2.4.4 Full 128 ASCII set and binary data. The full 128 ASCII set shall include all characters, symbols, and functions available within the ASCII code. In addition, all 7-bit combinations are acceptable. See figure A-8. For digital data communications, even that using ASCII characters and binary bits, the information: (a) shall be enclosed within a sequence of DATA (and REPEAT) words; (b) shall be preceded by an associated COMMAND (such as data text message) which designates the usage of information which follows; and (c) shall be preceded by a valid and appropriate calling cycle using the basic 38 subset addressing. No parity bits are transmitted, because the integrity of the information is protected by the basic ALE FEC and redundancy and may be ensured by optional use of the COMMAND CRC as described in section 80.

60.3 Coding.

60.3.1 Introduction. The effective performance of stations, while communicating over adverse rf channels, relies on the combined use of forward error correction, interleaving, and redundancy. These functions shall be performed within the transmit encoder and receive decoder.

60.3.2 Forward error correction (FEC). The Golay (24, 12, 3) FEC code is prescribed for this standard. The FEC code generator polynomial shall be:

$$g(x) = x^{11} + x^9 + x^7 + x^6 + x^5 + x + 1$$

The generator matrix G, derived from g(x), shall contain an identity matrix I<sub>12</sub> and a parity matrix P as shown on figure A-9. The corresponding parity check matrix H shall contain a transposed matrix p<sup>T</sup> and an identity matrix I<sub>12</sub> as shown on figure A-12.

60.3.2.1 Encoding. Encoding shall use the fundamental formula  $\underline{x} = \underline{u}G$ , where the code word  $\underline{x}$  shall be derived from the data word  $\underline{u}$  and the generator matrix G. Encoding is performed using the G matrix by summing (modulo-2) the rows of G for which the corresponding information bit is a "1". See figures A-9, A-10, and A-11.

60.3.2.2 Decoding. Decoding will implement the equation

$$\underline{s} = \underline{y} H^T$$

where  $\underline{y} = \underline{x} + \underline{e}$  is a received vector which is the modulo-2 sum of a code word  $\underline{x}$  and an error vector  $\underline{e}$ ,  $\underline{s}$  is a vector of "n - k" bits called the syndrome. See figure A-11B. See figure A-12 for the value of H. Each correctable/detectable error vector  $\underline{e}$  results in a unique vector  $\underline{s}$ . Because of this,  $\underline{s}$  is computed according to the equation above and is used to index a look-up of the corresponding  $\underline{e}$ , which is then added modulo-2 to  $\underline{y}$  to give the original code word  $\underline{x}$ . Flags are set according to the number of errors being corrected. The uses of the flags are described in 60.4. If  $\underline{s}$  is not equal to 0 and  $\underline{e}$  contains more ones than the number of errors being corrected by the decoding mode, a detected error is indicated and the appropriate flag is set.

MIL-STD-188-141A

APPENDIX A

BITS					0	0	0	0	0	1	0	1	0	0	1	0	0	1	0	1	0	0	1	0	1	0	1	1	1	1	1
b <sub>7</sub>	b <sub>6</sub>	b <sub>5</sub>	b <sub>4</sub>	b <sub>3</sub>	b <sub>2</sub>	b <sub>1</sub>	0	1	2	3	4	5	6	7	8	9	10	11	12	13	14	15	16	17	18	19	20	21	22	23	24
COLUMNS							0	1	2	3	4	5	6	7	8	9	10	11	12	13	14	15	16	17	18	19	20	21	22	23	24
ROWS							0	1	2	3	4	5	6	7	8	9	10	11	12	13	14	15	16	17	18	19	20	21	22	23	24
0	0	0	0	0	0	0	NUL	DLE	SP	!	"	#	\$	%	&	'	(	)	*	+	,	-	.	/							
0	0	0	0	1	0	0	SOH	DC1	!	"	#	\$	%	&	'	(	)	*	+	,	-	.	/								
0	0	1	0	0	0	0	STX	DC2	"	#	\$	%	&	'	(	)	*	+	,	-	.	/									
0	0	1	1	0	0	0	ETX	DC3	#	\$	%	&	'	(	)	*	+	,	-	.	/										
0	1	0	0	0	0	0	EOT	DC4	\$	%	&	'	(	)	*	+	,	-	.	/											
0	1	0	1	0	0	0	ENQ	NAK	%	&	'	(	)	*	+	,	-	.	/												
0	1	1	0	0	0	0	ACK	SYN	&	'	(	)	*	+	,	-	.	/													
0	1	1	1	0	0	0	BEL	ETB	'	(	)	*	+	,	-	.	/														
1	0	0	0	0	0	0	BS	CAN	(	)	*	+	,	-	.	/															
1	0	0	1	0	0	0	HT	EM	)	*	+	,	-	.	/																
1	0	1	0	0	0	0	LF	SUB	*	+	,	-	.	/																	
1	0	1	1	0	0	0	VT	ESC	+	,	-	.	/																		
1	1	0	0	0	0	0	FF	FS	,	-	.	/																			
1	1	0	1	0	0	0	CR	GS	-	.	/																				
1	1	1	0	0	0	0	SO	RS	.	/																					
1	1	1	1	0	0	0	SI	US	/																						
1	1	1	1	1	0	0	DEL																								

FIGURE A-8. Full 128 ASCII set.

## MIL-STD-188-141A

## APPENDIX A

	$I_{12}$	P
$G =$	100 000 000 000	: 101 011 100 011
	010 000 000 000	: 111 110 010 010
	001 000 000 000	: 110 100 101 011
	000 100 000 000	: 110 001 110 110
	000 010 000 000	: 110 011 011 001
	000 001 000 000	: 011 001 101 101
	000 000 100 000	: 001 100 110 111
	000 000 010 000	: 101 101 111 000
	000 000 001 000	: 010 110 111 100
	000 000 000 100	: 001 011 011 110
	000 000 000 010	: 101 110 001 101
	000 000 000 001	: 010 111 000 111

FIGURE A-9. Generator matrix for (24, 12) extended Golay code.



## MIL-STD-188-141A

## APPENDIX A

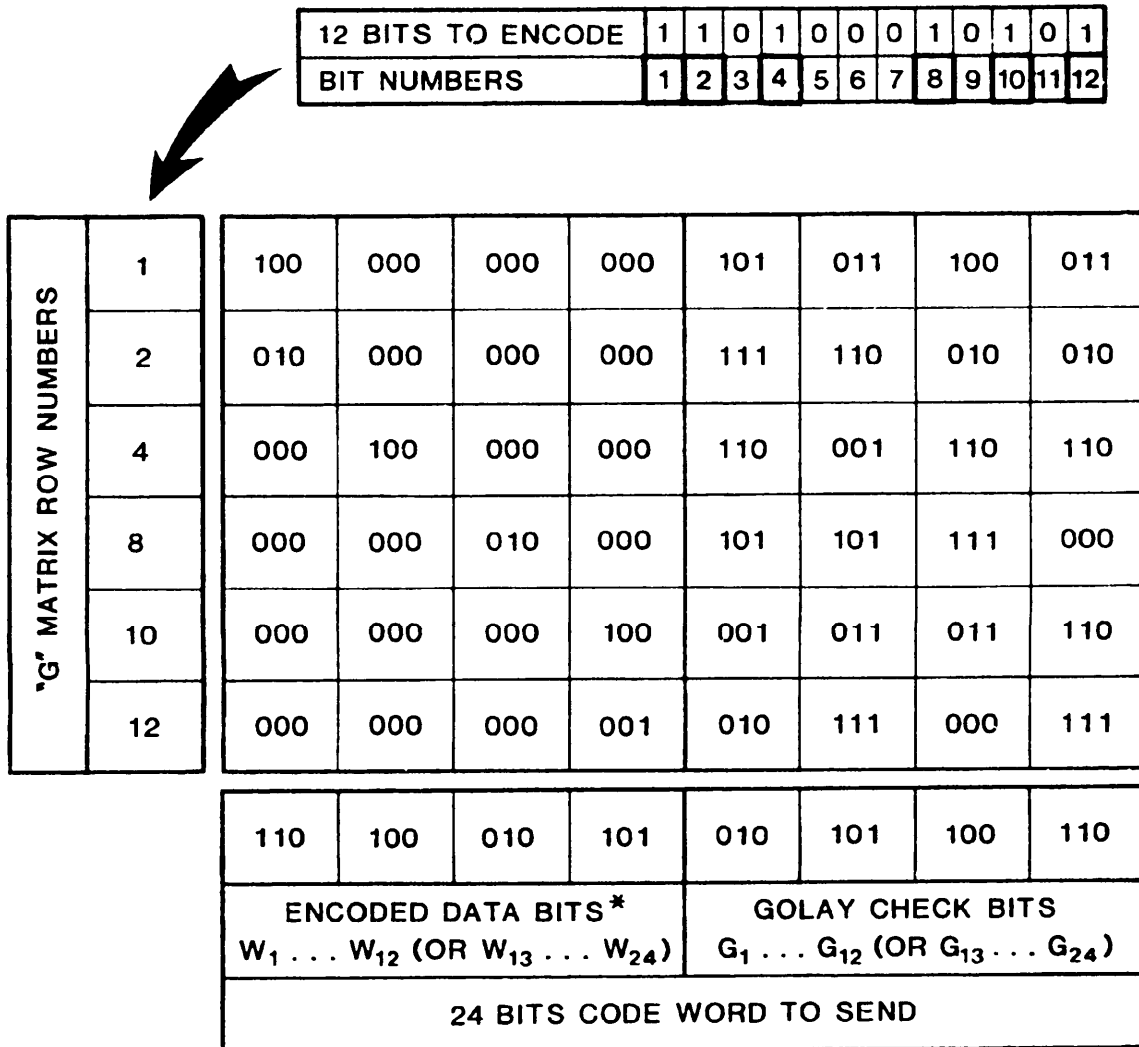

\*SEE NOTE 2

**NOTES:**

1. THE "1" BITS TO BE ENCODED DETERMINE WHICH ROWS OF THE "G" GENERATOR MATRIX ARE TO BE "MODULO-2" SUMMED. IN THIS EXAMPLE, BITS 1, 2, 4, 8, 10, AND 12 ARE "1", SO ROWS 1, 2, 4, 8, 10, AND 12 ARE SUMMED.
2. SINCE THIS IS A "SYSTEMATIC" CODE, THE ORIGINAL 12 DATA BITS ALSO APPEAR IN THE OUTPUT ENCODED 24 BITS.

FIGURE A-10. Golay word encoding example.

## MIL-STD-188-141A

## APPENDIX A

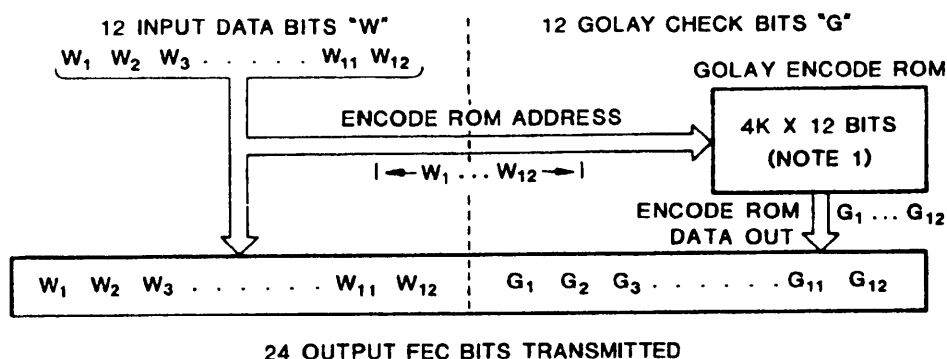

## A. GOLAY FEC ENCODING EXAMPLE

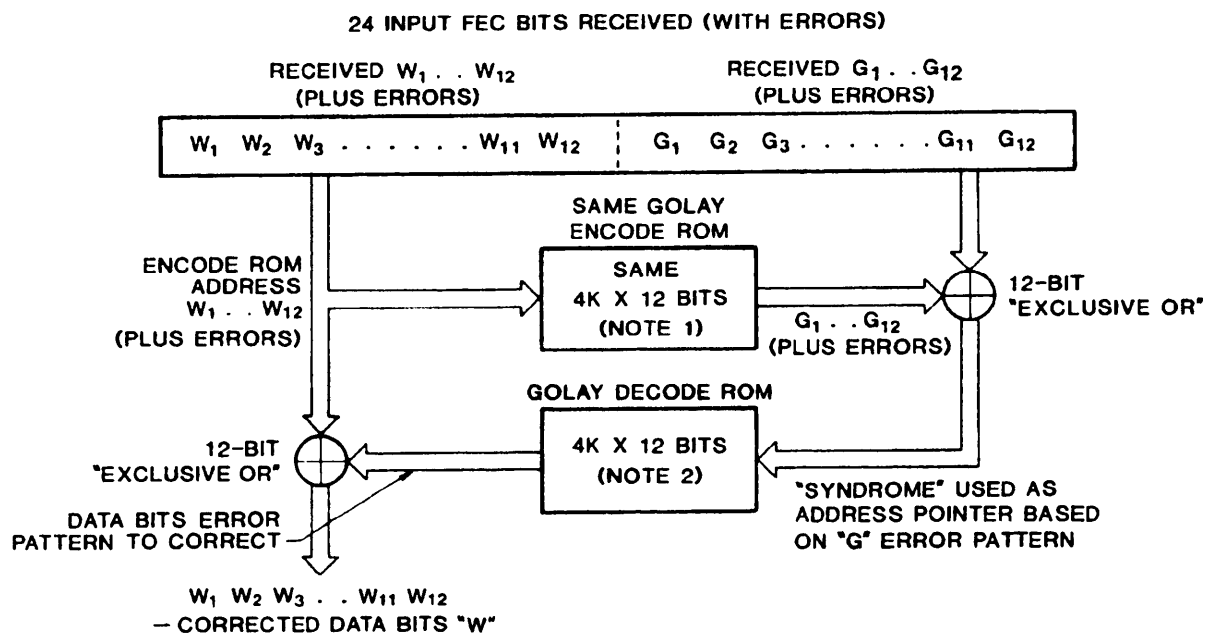

## B. GOLAY FEC DECODING EXAMPLE

## NOTES:

1. ENCODE ROM CONTAINS GOLAY CHECK BITS " $G_1 \dots G_{12}$ " AT EACH ADDRESS, BASED ON DATA BITS " $W_1 \dots W_{12}$ " PREVIOUSLY COMPUTED FROM GENERATOR MATRIX "G" AND STORED.
2. DECODE ROM MAY INCLUDE ADDITIONAL BITS (OVER THE BASIC 12 TO CORRECT "W" BITS) TO INDICATE QUANTITY OF DATA ERRORS DETECTED AND CORRECTABILITY.
3. ROM "LOOK UP" HARDWARE FOR EXAMPLE ONLY. SOFTWARE IMPLEMENTATIONS MAY BE PREFERRED.

FIGURE A-11. Golay FEC coding examples.

## MIL-STD-188-141A

## APPENDIX A

$$\begin{array}{c}
 \text{H} = \left( \begin{array}{cccc|cccc}
 & & p^T & & & & I_{12} & \\
 & & & & & & & \\
 111 & 110 & 010 & 010 & : & 100 & 000 & 000 & 000 \\
 011 & 111 & 001 & 001 & : & 010 & 000 & 000 & 000 \\
 110 & 001 & 110 & 110 & : & 001 & 000 & 000 & 000 \\
 011 & 000 & 111 & 011 & : & 000 & 100 & 000 & 000 \\
 110 & 010 & 001 & 111 & : & 000 & 010 & 000 & 000 \\
 100 & 111 & 010 & 101 & : & 000 & 001 & 000 & 000 \\
 101 & 101 & 111 & 000 & : & 000 & 000 & 100 & 000 \\
 010 & 110 & 111 & 100 & : & 000 & 000 & 010 & 000 \\
 001 & 011 & 011 & 110 & : & 000 & 000 & 001 & 000 \\
 000 & 101 & 101 & 111 & : & 000 & 000 & 000 & 100 \\
 111 & 100 & 100 & 101 & : & 000 & 000 & 000 & 010 \\
 101 & 011 & 100 & 011 & : & 000 & 000 & 000 & 001
 \end{array} \right)
 \end{array}$$

FIGURE A-12. Parity-check matrix for (24, 12) extended Golay code.

## MIL-STD-188-141A

## APPENDIX A

60.3.3 Interleaving and deinterleaving. The basic word bits W1 (MSB) through W24 (LSB), and resultant Golay FEC bits G1 through G24 (with G13 through G24 inverted), shall be interleaved, before transmission using the pattern shown on figure A-13. The 48 interleaved bits plus a 49th stuff bit S49, (value = 0) shall constitute a transmitted word and they shall be transmitted A1, B1, A2, B2... A24, B24, S49 using 16-1/3 symbols (tones) per word (Tw) as described in 50.3. At the receiver, and after 2/3 voting (see 60.3.4), the first 48 received bits of the majority word (including remaining errors) shall be deinterleaved as shown on figure A-13 and then Golay FEC decoded to produce a correct(ed) 24-bit basic word (or an uncorrected error flag). The 49th stuff bit (S49) is ignored.

60.3.4 Redundant words. Each of the transmitted 49-bit (or 16-1/3 symbol) (Tw) words shall be sent redundantly (times 3) to reduce the effects of fading, interference, and noise. An individual (or net) routing word (TO...), used for calling a scanning (multichannel) station (or net), shall be sent redundantly as long as required in the scan call (Tsc) to ensure receipt, as described in 70.4. However, when the call is a non-net call to multiple scanning stations (a group call, using THRU and REPEAT alternately), the first individual routing word (THRU) and all the subsequent individual routing words (REPEAT, THRU, REPEAT,...) shall be sent three adjacent times (Trw). These triple words for the individual stations shall be rotated in group sequence as described in 70.6. See figure A-14. At bit time intervals (approximately Tw/49), the receiver shall examine the present bit and past bit stream and perform a 2/3 majority vote, on a bit-by-bit basis, over a span of three words. See tables A-VII and A-VIII. The resultant 48 (ignoring the 49th bit) most recent majority bits constitute the latest majority word and shall be delivered to the deinterleaver and FEC decoder. In addition, the number of unanimous votes of the 48 possible votes associated with this majority word are temporarily retained for use as described in 60.4.

60.4 Word framing and synchronization.

60.4.1 General. The ALE system is inherently asynchronous and does not require any additional forms of system synchronization, although it is compatible with such techniques. However, the imbedded timing and structure of the system provide specific synchronous benefits in linking, orderwire, and anti-interference functions, as described herein.

60.4.2 Framing. All ALE transmissions, commonly referred to herein as "calls," are based on the tones, timing, bit, and word structures described in sections 50 and 60.2. All calls shall be composed of a "frame," which shall be constructed of contiguous redundant words in valid sequence(s) as described on figure A-5, as limited in table A-VI, and in formats as described in section 70. There are three basic frame sections: calling cycle, message, and conclusion. See 60.4.2.4 for basic frame structure examples.

MIL-STD-188-141A

APPENDIX A

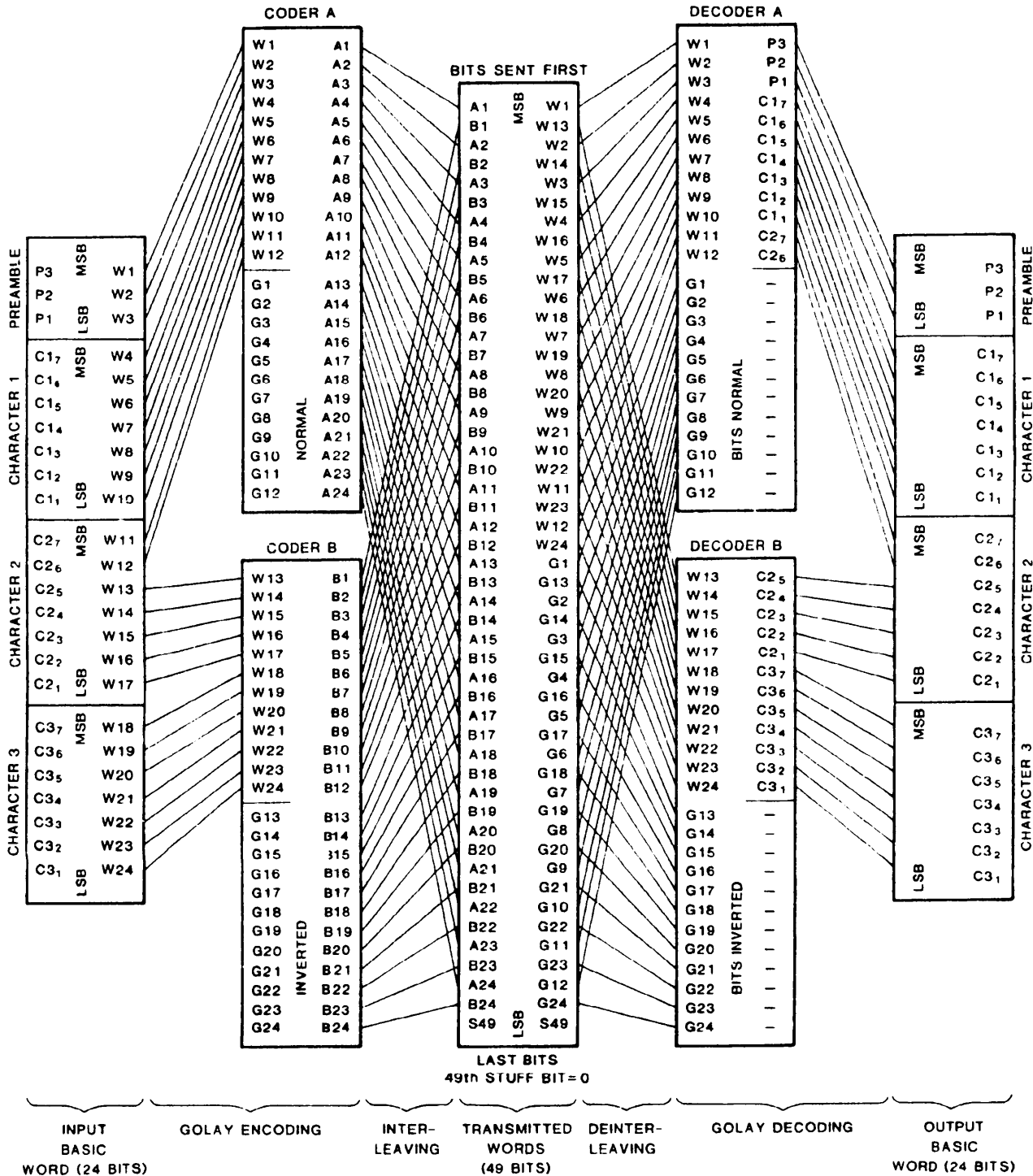
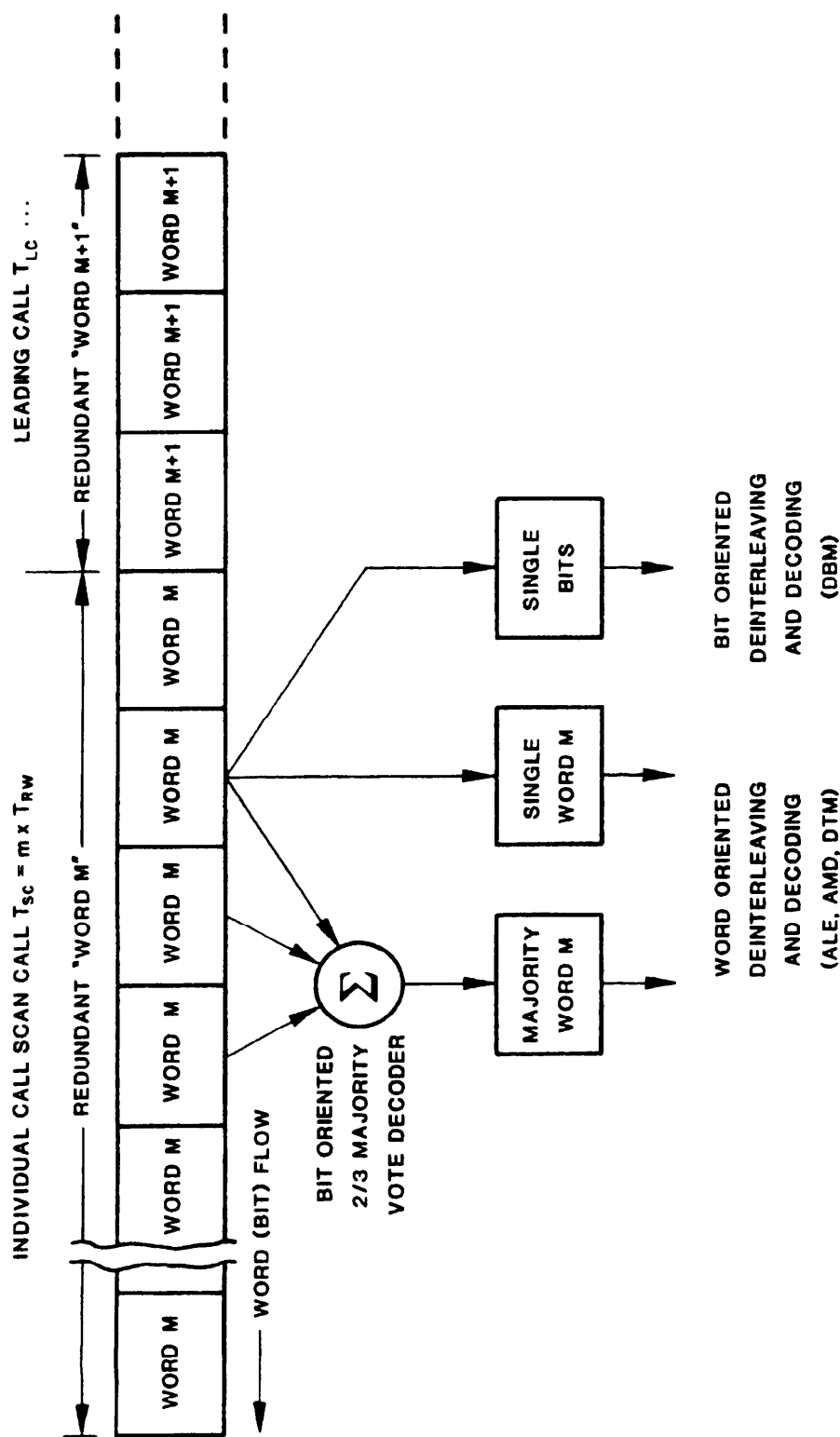

FIGURE A-13. Word bit coding and interleaving.

MIL-STD-188-141A

APPENDIX A



NOTES:

1. USE OF 2/3 VOTING REQUIRES EACH WORD M TO BE TRANSMITTED AT LEAST THREE ADJACENT TIMES.
2. DBM IS DATA BLOCK MESSAGE;  
AMD IS AUTOMATIC MESSAGE DISPLAY;  
DTM IS DATA TEXT MESSAGE.

FIGURE A-14. Bit and word decoding.

## MIL-STD-188-141A

## APPENDIX A

TABLE A-VII. 2/3 Majority vote decoding.

Received bit R	Received time	Eight possible bit combinations							
R(n) (now)	T	0	0	0	0	1	1	1	1
R(n-49) (Tw old)	T-130.66... ms	0	0	1	1	0	0	1	1
R(n-98) (2 Tw old)	T-261.33... ms	0	1	0	1	0	1	0	1
Resultant majority bit M:		0	0	0	1	0	1	1	1
Possible error flag:		0	1	1	1	1	1	1	0
0 = error unlikely 1 = error likely									

TABLE A-VIII. Majority word construction.

Relative time	Received bits R (time) for 2/3 voting			Majority words bit M	Used as decoder bits
Stuff bits	R(n)	R(n-49)	R(n-98)	M(n)	S49 ignored
Recent (LSB)	R(n-1)	R(n-50)	R(n-99)	M(n-1)	B24 (LSB)
	R(n-2)	R(n-51)	R(n-100)	M(n-2)	A24
	R(n-3)	R(n-52)	R(n-101)	M(n-3)	B23
	R(n-4)	R(n-53)	R(n-102)	M(n-4)	A23
	⋮	⋮	⋮	⋮	⋮
	⋮	⋮	⋮	⋮	⋮
	⋮	⋮	⋮	⋮	⋮
	R(n-46)	R(n-95)	R(n-144)	M(n-46)	A2
	R(n-47)	R(n-96)	R(n-145)	M(n-47)	B1
Older (MSB)	R(n-48)	R(n-97)	R(n-146)	M(n-48)	A1 (MSB)

## NOTES:

1. "n" indicates present bit time
2. "n-m" indicates bit received at "m" bit times earlier

## MIL-STD-188-141A

## APPENDIX A

60.4.2.1 Calling cycle. The initial section of all calls (except sounds) is termed a calling cycle (Tcc), and it is divided into two parts: a scanning call (Tsc) and a leading call (Tlc). The scanning call shall be composed of T0 words if an individual or net call (or THRU and REPEAT words, alternating, if a group call), which contain only the address first word(s) of the called station(s) or net. The leading call shall be composed of T0 (and possibly DATA and REPEAT) words containing the whole address(es) for the called station(s), from initiation of the leading call until the start of the message section or the conclusion (thus the end of the calling cycle). See figure A-15. The use of REPEAT and DATA is described in 60.5. The set of different address first words (Tcl) may be repeated as necessary for scanning calling (Tsc), to exceed the scan period (Ts). There is no unique "flag word" or "sync word" for frame synchronization (as discussed below). Therefore, stations may acquire and begin to read an ALE signal at any point after the start. The start of the call shall be initiated after the transmitter has risen to at least 90 percent of the rated rf output power. The end of the calling cycle may be indicated by the start of the optional quick-ID, which occupies the first words in the message section, after the leading call and before the start of the rest of the message (or conclusion, if no message) section.

NOTE: The frame start time may need to be delayed (equipment manufacturer dependent) to avoid loss of the leading words if the transmitter attack time is significantly long. Alternatively, the modem may transmit repeated duplicates of the scanning cycle (set of) first word(s) to be sent (not to be counted in the frame) as the transmitter rises to full power (and may even use the ALE signal momentarily instead of a tuning tone for the tuner), and then start the frame when the power is up.

60.4.2.2 Message. The second and optional section of all calls (except sounds) is termed a "message." Except for the quick-ID, it shall be composed of COMMAND (and possibly REPEAT and DATA) words from the end of the calling cycle until the start of the conclusion (thus the end of the message). The optional quick-ID shall be composed of FROM (and possibly REPEAT and DATA) word(s), containing the transmitter's whole address. It shall only be used once at the start of the COMMAND message section sequences. The quick-ID enables prompt transmitter identification and should be used if the message section length is a concern. It is never used without a following (COMMAND...) message(s). The message section shall always start with the first COMMAND (or FROM with later COMMAND(s)) in the call. See figure A-16. The use of REPEAT and DATA is described in section 80. The message section is not repeated within the call (although messages or information itself, within the message section, may be).



MIL-STD-188-141A

APPENDIX A

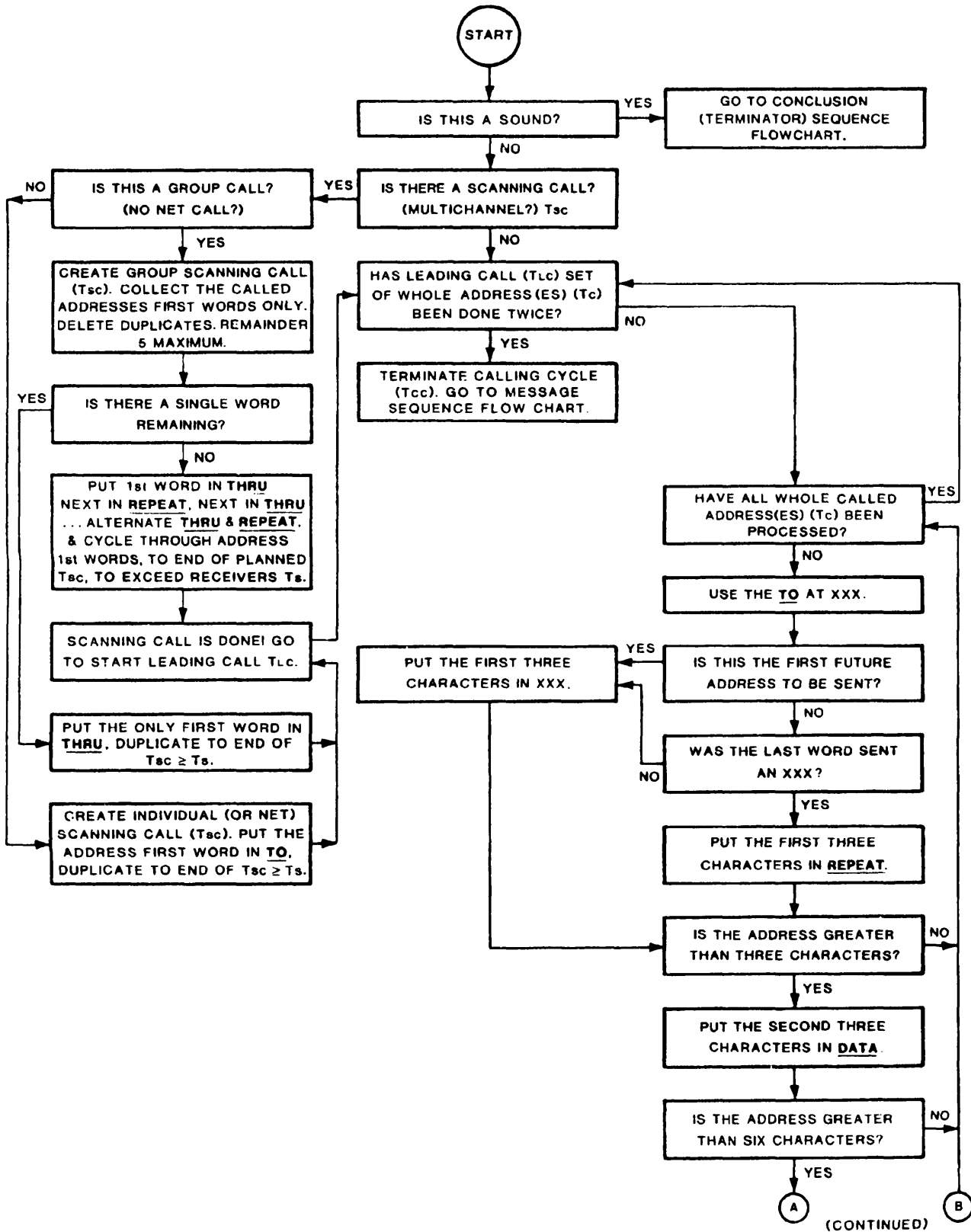
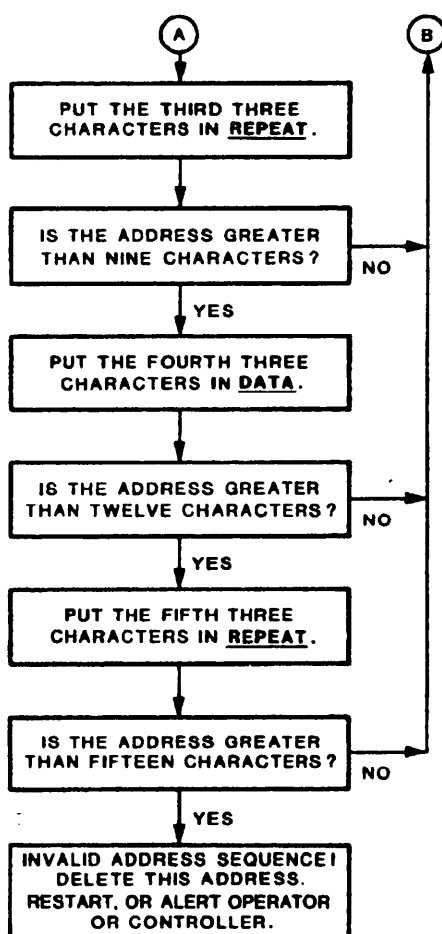

FIGURE A-15. Calling cycle sequences.

## MIL-STD-188-141A

## APPENDIX A

FIGURE A-15. Calling cycle sequences -- Continued.

## MIL-STD-188-141A

## APPENDIX A

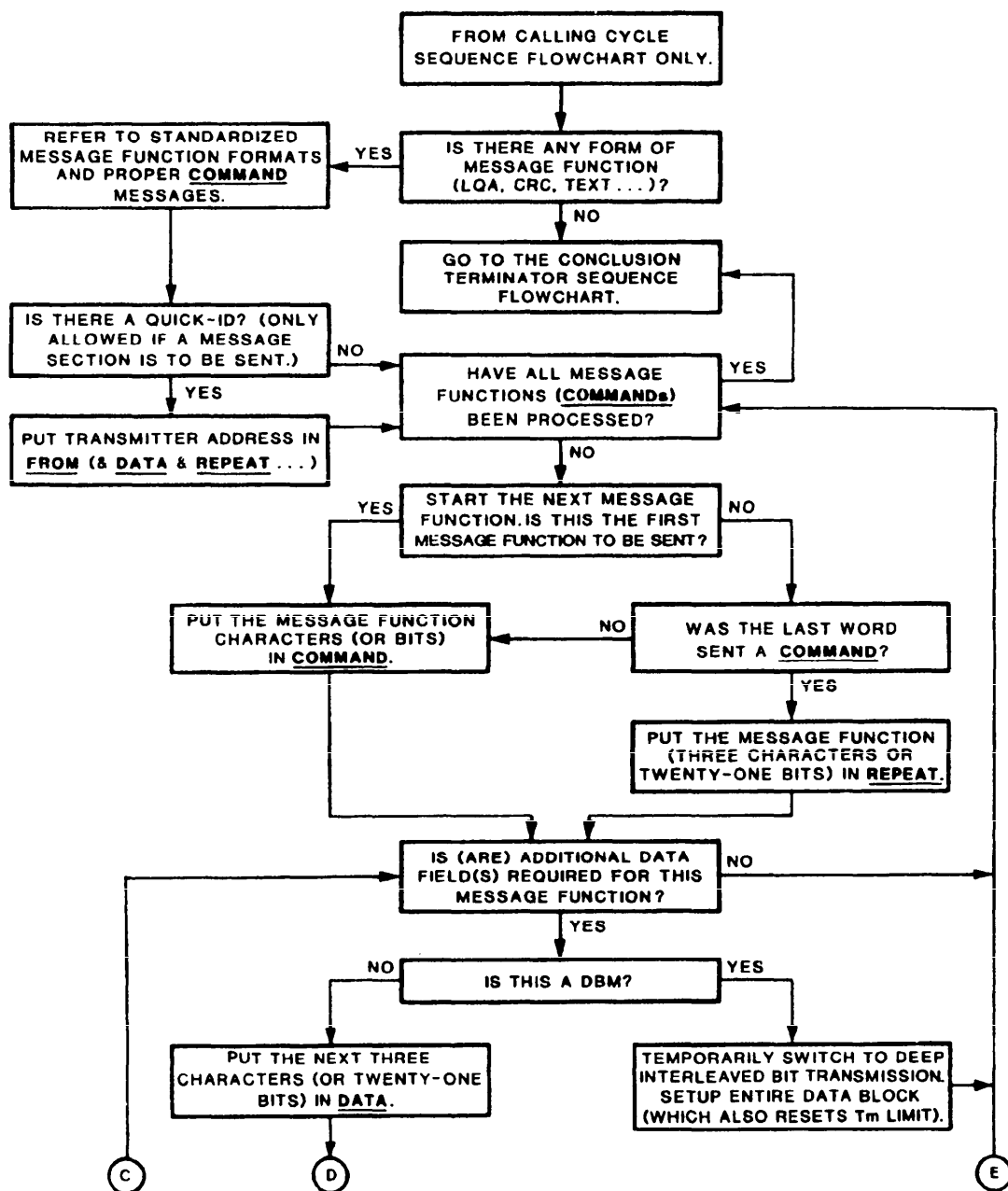
FIGURE A-16. Message sequences.

## MIL-STD-188-141A

## APPENDIX A

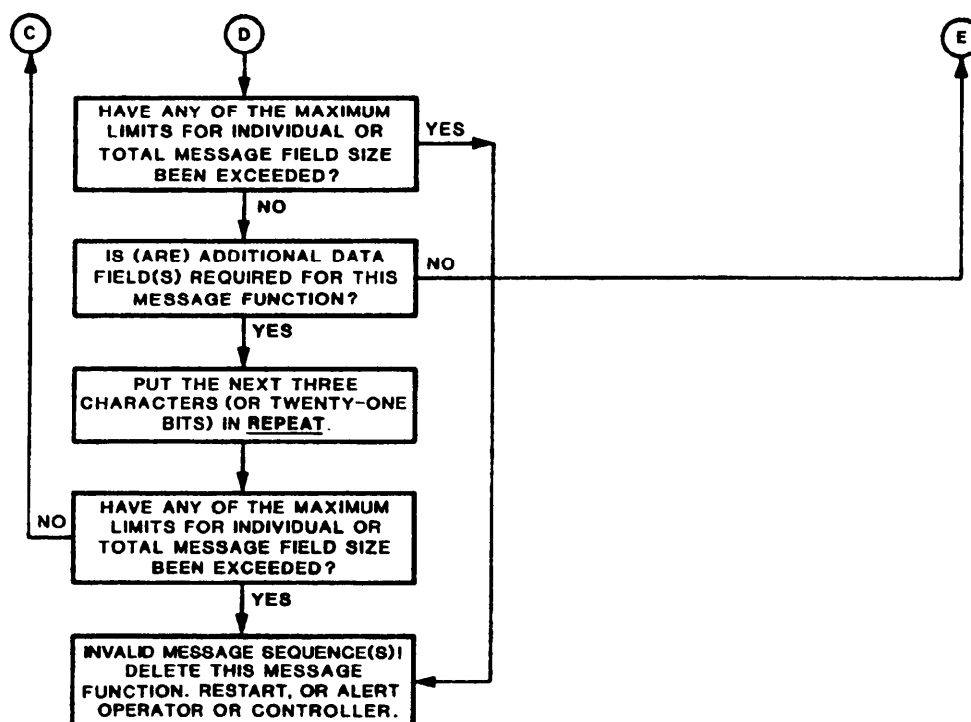
FIGURE A-16. Message sequences -- Continued.

## MIL-STD-188-141A

## APPENDIX A

60.4.2.3 Conclusion. The third section of all calls is termed a "conclusion." It shall be composed of either THIS IS or THIS WAS (but not both) (and possibly DATA and REPEAT) words, from the end of the message (or calling cycle sections, if no message) until the end of the call. See figure A-17. Sounds, an exception, shall start immediately with THIS IS (or THIS WAS) words as described in 70.5. REPEAT shall not immediately follow THIS IS or THIS WAS. Both conclusions and sounds contain the whole address of the transmitting station.

60.4.2.4 Basic frame structure examples. Contained in figure A-18 are basic examples (does not include the optional message section) of frame construction. Included are single-word and multiple-word examples of either single or multiple called station address(es) for nonscan (single-channel) and scanning (multiple-channel) use in individual, net, or group calls.

60.4.3 Synchronization.

60.4.3.1 Transmit modulator. The ALE transmit modulator accepts digital data from the encoder and provides modulated baseband audio to the transmitter. The signal modulation is strictly timed as described in 50.3 and 50.4. After the start of the first transmission in a handshake (or exchange or other protocol within this document) by a station, the ALE transmit modulator shall maintain a constant phase relationship, within the specified timing accuracy, among all transmitted triple redundant words, at all times, until the link handshake (including the exchange and any ALE protocol) is terminated. Specifically,

$$T(\text{later triple redundant word}) - T(\text{early triple redundant word}) = n \times Trw$$

where  $T(\ )$  is the event time of a given triple redundant word,  $Trw$  is the period of three words (392 ms), and  $n$  is any integer.

The internal word phase reference of the transmit modulator shall be independent of the receiver (which tracks incoming signals) and shall be self timed (within its required accuracy). See 50.4. Therefore all transmissions after the first (in a handshake) shall synchronize by adding a delay  $Trwp = 0$  to 392 ms after the time the controller would normally initiate the next transmission.

60.4.3.2 Receive demodulator. The receive demodulator accepts baseband audio from the receiver, acquires, tracks, and demodulates ALE signals, and provides the recovered digital data to the decoders. See figure A-14. In data block message (DBM) mode, the receive demodulator shall also be capable of reading single data bits for deep deinterleaving and decoding.

60.4.3.3 Synchronization criteria. The decoder accepts digital data from the receive demodulator and performs deinterleaving, decoding, FEC, and data checking. During initial and continuing synchronization, all of the following criteria shall be used to discriminate and read every ALE word:

## MIL-STD-188-141A

## APPENDIX A

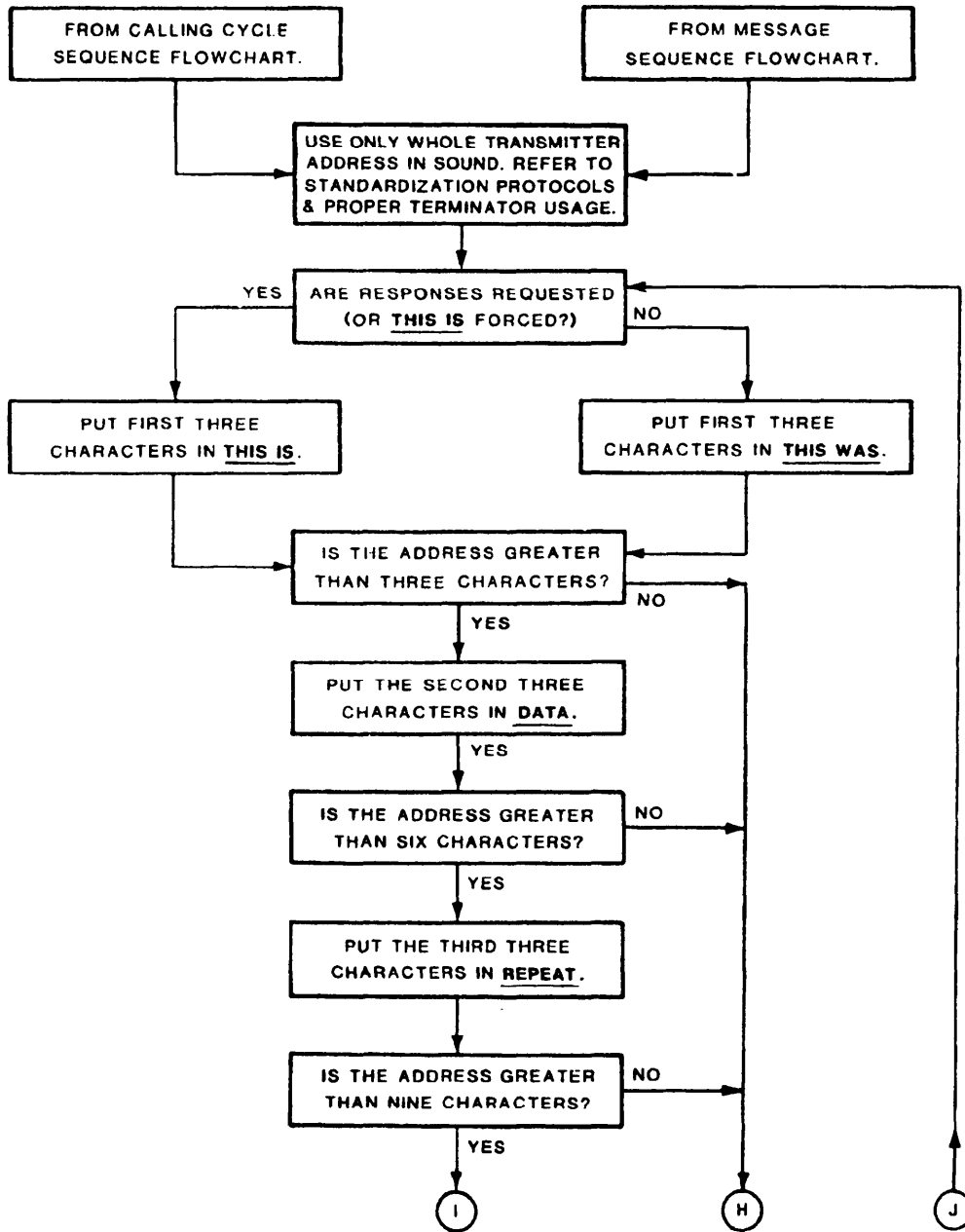
FIGURE A-17. Conclusion (terminator) sequences.

MIL-STD-188-141A

APPENDIX A

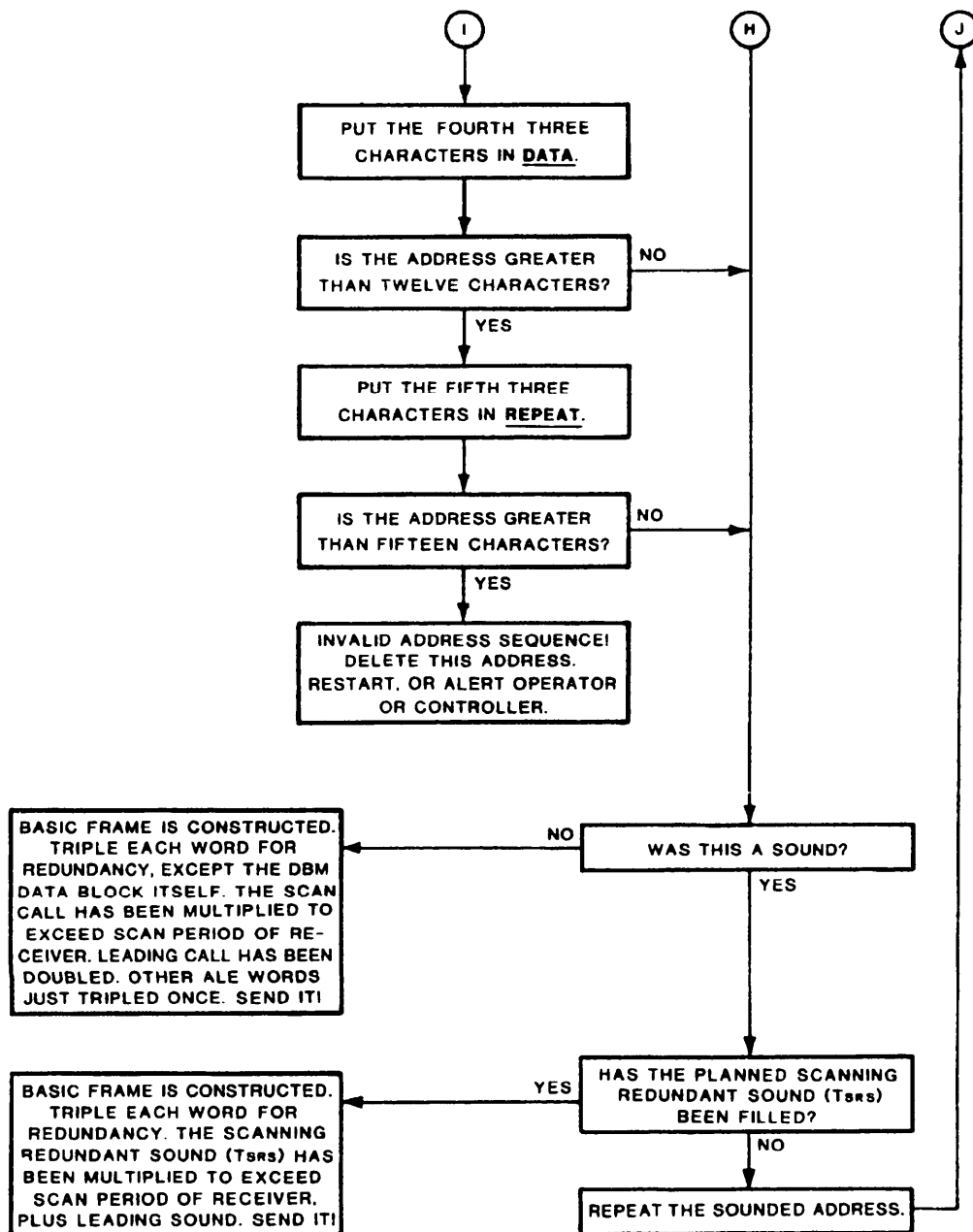
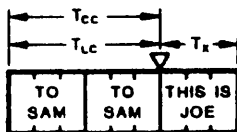

FIGURE A-17. Conclusion (terminator) sequences -- Continued.

## MIL-STD-188-141A

## APPENDIX A



A. 1-CHANNEL NONSCAN, 1-WORD ADDRESSING, DIRECT, INDIVIDUAL (OR NET) CALL.

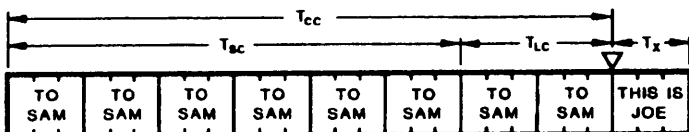

B. N-CHANNEL SCANNING, 1-WORD ADDRESSING, DIRECT, INDIVIDUAL (OR NET) CALL.

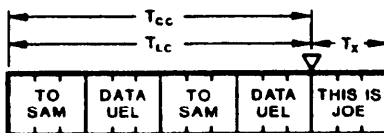

C. 1-CHANNEL NONSCAN, 2-WORD ADDRESSING, DIRECT, INDIVIDUAL (OR NET) CALL.

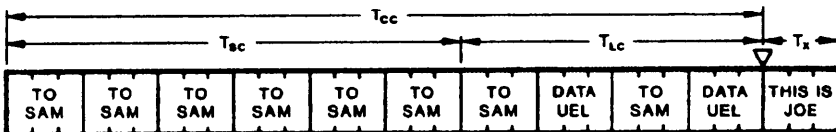

D. N-CHANNEL SCANNING, 2-WORD ADDRESSING, DIRECT, INDIVIDUAL (OR NET) CALL.

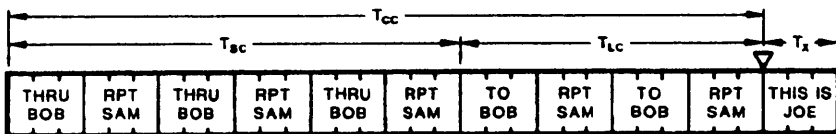

E. N-CHANNEL SCANNING, 1-WORD ADDRESSING, DIRECT, GROUP CALL.

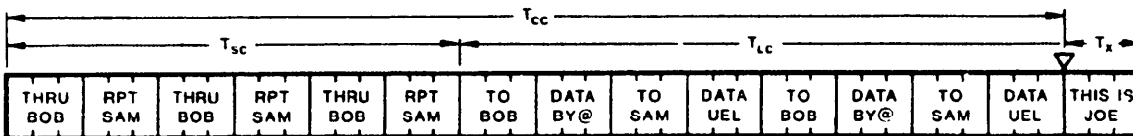

F. N-CHANNEL SCANNING, 2-WORD ADDRESSING, DIRECT, GROUP CALL.

FIGURE A-18. Basic frame structure examples.



## MIL-STD-188-141A

## APPENDIX A

- o Must meet or exceed a threshold of unanimous votes in the 2/3 majority vote decoder
- o Successful Golay decode of "A" word bits
- o Successful Golay decode of "B" word bits
- o Acceptable preamble according to valid word sequences as shown on figure A-5.
- o Acceptable first character bits (of basic 38 subset)
- o Acceptable second character bits (of basic 38 subset)
- o Acceptable third character bits (of basic 38 subset)
- o History, status, expectations, and protocol
- o Correct triple redundant word phase

The number of unanimous votes provides an easily adjustable BER signal quality discrimination, and the threshold should be chosen by the manufacturer to optimize performance. A successful Golay decode indicates that all detected bit errors were corrected within the power of the FEC code; that is, the errors were within correctable limits and therefore, the uncorrectable error flag(s) did not occur. The correction power (mode) of the Golay code should be chosen by the manufacturer to optimize performance using any of the four modes: (3/4, 2/5, 1/6, 0/7) where n/m indicates up to "n" errors detected and corrected, or up to "m" errors detected but not correctable. Acceptable preambles, as described here and defined in 60.2.2, refer to those preambles which are within the limits of this standard. As a DO, automatic adjustment of the unanimous vote threshold and Golay mode should be provided to optimize performance under varying conditions.

NOTE: The application of each preamble is dependent on the recent signaling history of the stations heard, the active status of the machine, the handshake(s) expected, and the protocol being used, if any. For example, an uncommitted station, awaiting calls, would accept TO if individual or net call (and possibly THRU or REPEAT if group call) as valid preambles for calls to it. It would reject COMMAND as being irrelevant (because it missed the preceding and required calling cycle Tcc). It might also reject THIS IS or THIS WAS (unless collecting sounding information). Acceptable characters means that each character is within the appropriate ASCII subset. Note that all criteria, together, must be satisfied to accept a word. For example, all three characters would have to be within the basic 38 subset if a routing preamble, such as a TO, was decoded. Likewise, any bit combination would be conditionally acceptable if an initial REPEAT was received, but in most cases, without the necessary knowledge of the previous word, it would be considered irrelevant and should be rejected.

## 60.5 Addressing.

60.5.1 Introduction. The ALE system deploys a digital addressing structure based upon the standard 24-bit (three character) word and the basic 38 ASCII character subset. As described below, ALE stations have the capability and flexibility to link or network with one or many prearranged or as-needed single or multiple stations. All ALE stations shall have the

## MIL-STD-188-141A

## APPENDIX A

capacity to store and use at least 20 self addresses of up to 15 characters each in any combination of individual and net calls. There are three basic addressing methods which will be presented:

- o Individual station
- o Multiple station
- o Special modes

NOTE: Certain alphanumeric address combinations may be interpreted to have special meanings for emergency or specific functions, such as "SOS", "MAYDAY", "PANPAN", "SECURITY", "ALL", "ANY", and "NULL". These should be carefully controlled or restricted.

60.5.2 Individual station. The fundamental address element in the ALE system is the single routing word, containing three characters, which forms the basic individual station address. This basic address word, used primarily for intranet and slotted operations, may be extended to multiple words and modified to provide increased address capacity and flexibility for internet and general use. An address which is assigned to a single station (within the known or used network) shall be termed an "individual" address. If it consists of one word (that is, no longer than three characters) it shall be termed a "basic" size, and if it exceeds one word, it shall be termed an "extended" size.

60.5.2.1 Basic. The basic address word shall be composed of a routing preamble (TO, or possibly a REPEAT which follows a TO, in T1c of group call, or a THIS IS or THIS WAS) plus three address characters, all of which shall be the alphanumeric members of the basic 38 ASCII subset. The use of the utility symbols "@" and "?", shall be as described in 60.5.4. The three characters in the basic individual address provide a basic 38-address capacity of 46,656, using only the 36 alphanumerics. This three-character single word is the minimum structure. Use of only one or two characters is discouraged because they provide a basic 38-address capacity of only 36 or 1296, respectively, with no significant advantages such as speed, capacity, or reliability. As examples of proper usage, a minimum three-character call directed to "JIM" would be structured "TO JIM", and a shorter (discouraged) two-character call to "ED" would be structured "TO ED@". Both would have identical size and performance characteristics. One-word addresses should be used only for abbreviated address intranet and slotted response operations, and longer two-word (or more) addresses should be used for intranet, internet, and general operations. All ALE stations shall be assigned at least one (DO: several) single-word address for automatic use in one-word address protocols, such as slotted (multistation type) responses. In addition, all ALE stations shall associate specific timing and control information with all own addresses, such as prearranged delays for slotted net responses. As described in section 70, the basic individual addresses of various station(s) may be combined to implement flexible linking and networking.

## MIL-STD-188-141A

## APPENDIX A

60.5.2.2 Extended. Extended addresses provide address fields which are longer than one word (three characters), up to a maximum system limit of five words (15 characters). See table A-IX. This 15-character capacity enables Integrated Services Digital Network (ISDN) address capability. Specifically, the ALE extended address word structure shall be composed of an initial basic address word, such as TO or THIS IS, as described above, plus additional words as necessary to contain the additional characters in the sequence DATA, REPEAT, DATA, REPEAT, for a maximum total of five words. All address characters shall be the alphanumeric members of the basic 38 subset. The use of the utility symbols "@" and "?" is described in 60.5.4. All ALE stations shall be assigned at least one (DO: several) two-word address(es) for general use, plus an additional address(es) containing the station's assigned call sign(s).

NOTE: The recommended standard address size for intranet, internet, and general non-ISDN use is two words. Any requirement to operate with address sizes larger than six characters must be a network management decision. As examples of proper usage, a call to "EDWARD" would be "TO EDW", "DATA ARD", and a call to "MISSISSIPPI" would be "TO MIS", "DATA SIS", "REPEAT SIP", "DATA PI@".

60.5.3 Multiple stations. It is a critical requirement to simultaneously (or nearly simultaneously) address and interoperate with multiple stations in MF and HF networks. A prearranged collection of stations, with a commonly assigned additional address, shall be termed a "net," and the common address shall be a "net address." A nonprearranged collection of stations, without a commonly assigned additional address, shall be termed a "group." Protocols for linking and networking with nets and groups are described in 70.6. It should be noted that the term "net" is also commonly used to identify any collection of stations which are, or were, interoperating, regardless of any prearrangements or the method of establishment. In this standard, the terms "net" and "group" usually specifically refer to the linking and networking methodology, not the subsequent traffic exchanges.

60.5.3.1 Net. As a prearranged collection of stations, a net may be organized and managed with significant prior knowledge of the member stations, including their quantities, identities, capabilities, requirements, and in most cases, their locations and necessary connectivities. Maximum advantage should be taken of this knowledge to optimize the net timing, addressing, and interchanges. The purpose of a net call is to rapidly and efficiently establish contact with multiple prearranged (net) stations (simultaneously if possible) by the use of a single net address, which is an additional address assigned to all net members in common. As described in 70.6, additional information concerning the assigned response slots (and size) must be available, and the mixing of individual, net, and group addresses and calls is restricted.

## MIL-STD-188-141A

## APPENDIX A

TABLE A-IX. Basic (38) address structures.

	Words	Address characters	Types
B A S I C	1	1	Stuff-2
	1	2	Stuff-1
	1	3	Basic
	2	4	Basic + Stuff-2
	2	5	Basic + Stuff-1
	2	6	2 Basic
	3	7	2 Basic + Stuff-2
E X T E N D E D	3	8	2 Basic + Stuff-1
	3	9	3 Basic
	4	10	3 Basic + Stuff-2
	4	11	3 Basic + Stuff-1
	4	12	4 Basic
	5	13	4 Basic + Stuff-2
	5	14	4 Basic + Stuff-1
	5 (limit)	15 (limit)	5 Basic (limit)

## NOTES:

1. Basic : ABC
2. Stuff-2: A@@
3. Stuff-1: AB@

## MIL-STD-188-141A

## APPENDIX A

When a net address type function is required, a calling ALE station shall use an address structure identical to the individual station address, basic or extended as necessary. For each net address at a net member's station, there shall be a response slot identifier, plus a slot width modifier if directed by the specific standard protocol.

60.5.3.2 Group. Unlike a net, a group is nonprearranged and, in many cases, little or nothing is known about the stations except their individual addresses and scanned frequencies. Despite this minimum of data, it is critical to be able to create a new group where none existed, and it requires a standardized protocol which is compatible with virtually all automated stations, essentially regardless of their individual, net, and other characteristics. The purpose of a group call is to establish contact with multiple nonprearranged (group) stations (simultaneously if possible) rapidly and efficiently by the use of a compact combination of their own addresses which are assigned individually.

When a group address type function is required, a calling ALE station shall use a sequence of the actual individual station addresses of the called stations, in the manner directed by the specific standard protocol. A station's address shall not appear more than once in a group calling sequence, except as specifically permitted in the group calling protocols described in 70.6.

#### 60.5.4 Special modes "@" and "?".

60.5.4.1 General. The special modes, which use the utility symbols "@" (1000000) and "?" (0111111) include the following:

- o Stuffing
- o Allcalls
- o Anycalls
- o Wildcards
- o Self address
- o Null address

60.5.4.2 Stuffing. The ALE basic address structure is based on single words which, in themselves, provide multiples of three characters. The quantity of available addresses within the system, and the flexibility of assigning addresses, are significantly increased by the use of address character stuffing. This technique allows address lengths which are not multiples of three to be compatibly contained in the standard (multiple of three characters) address fields by "stuffing" the empty trailing positions with the utility symbol "@". See table A-X. "Stuff-1" and "stuff-2" words shall only be used in the last word of an address, and therefore should appear only in the leading call (Tlc) of the calling cycle (Tcc).

NOTE: As an example of proper usage, a call to the address "MIAMI" would be structured "TO MIA", "DATA MI@".

## MIL-STD-188-141A

## APPENDIX A

TABLE A-X. Use of "@" utility symbol.

Pattern	Function	Guidance
TO A B C	"Standard" three-character address structure "ABC"	Any position in address and sequences
TO A B @	"Stuff-1" reduced-address field; adds two characters "A,B"	Only last word in address; anywhere in sequences
TO A @ @	"Stuff-2" reduced-address field; adds one character "A"	Only last word in address; anywhere in sequences
TO @ ? @	"Allcall" global address; all stop and listen (unless inhibited), none respond	Exclusive member of calling cycle; single <u>TO</u> only
TO REPEAT @ A @ @ B @ (option)	"Selective allcall": global address; all with same last character "A" (or "B") stop and listen (unless inhibited), none respond	Alone, or with additional different allcall selections, for "group selective allcall"; only in calling cycle; must use <u>TO</u> , <u>REPEAT</u> alternately never <u>DATA</u> , if more than one*
TO @ @ ?	"Anycall" global address; all stop and respond in PRN slots (unless inhibited), using own addresses	Exclusive member of calling cycle; single <u>TO</u> only
TO REPEAT @ @ A @ @ B (option)	"Selective anycall": all with same last character(s) "A" (or "B") stop and respond in PRN slots (unless inhibited), using own addresses	Alone, or with additional different anycall selections, for "group selective anycall"; only in calling cycle; must use <u>TO</u> , <u>REPEAT</u> alternately (never <u>DATA</u> ), if more than one*
TO REPEAT @ A B @ C D (option)	"Double selective anycall" all with same last characters "AB" (or "CD") stop and respond in PRN slots (unless inhibited) using own addresses	Alone, or with additional different anycall selections for "group double selective anycall"; only in calling cycle, must use <u>TO</u> , <u>REPEAT</u> alternately (never <u>DATA</u> ), if more than one*
TO @ @ @	"Null" address; all ignore, test and maintenance use, or extra "buffer" slot	Any position in address sequence (omit from Tsc if group call) except never in conclusion (terminator), or <u>REPEAT</u> , only, if following <u>TO</u>



## MIL-STD-188-141A

## APPENDIX A

TABLE A-X. Use of "@" utility symbol -- Continued.

## NOTES:

1. All patterns not shown here are reserved and shall be considered invalid until standardized.
2. "@" indicates special utility character (1000000); "?" wildcard (0111111).
3. "A", "B", "C", or "D" indicates any alphanumeric member of basic 38 subset other than "@", or "?", that is "A-Z" and "0-9".
4. \* THRU, REPEAT in TSC if group call.

60.5.4.3 Allcalls. An "allcall" is a general broadcast which does not request responses and does not designate any specific address. This essential function is required for emergencies ("HELP:"), sounding-type data exchanges, and propagation and connectivity tracking. See table A-X. If an ALE station requires an allcall type function, it shall use the following allcall protocols. The allcall special address structures shall be the exclusive members of the calling cycle (both Tsc and Tlc, of Tcc) in the initial call, shall not be used in any other address field or part of the handshake, and shall use the T0 words. The global allcall special address shall be "T0 @?@", with standard redundancy. It shall employ only the T0 preamble and shall not be followed by REPEAT or DATA. Upon receipt of the allcall, (and unless inhibited or otherwise directed by the operator or controller), all receiving allcalled stations shall temporarily stop their scan (for a preset limited time, Tcc max). If the message section or terminator section does not arrive within Tcc max, the station shall automatically resume scanning. If a quick-ID (indicated by a FROM after the calling cycle) arrives, the pause for the message section shall be extended for no more than five words (5 Trw), and if a COMMAND does not arrive, the station shall resume scanning. If a message arrives (indicated by receipt of a COMMAND), the station shall pause (for a preset limited time, Tm max) to read the message. If the terminator section does not arrive within Tm max, the station shall automatically resume scanning. If a terminator arrives (indicated by receipt of a THIS IS or THIS WAS), the station shall pause (for a preset limited time, Tx max) to read the caller's (transmitter's) address. If the end of the signal does not arrive within Tx max, the station shall automatically resume scanning. If the allcall is successfully received with a THIS IS, the called station shall stop scanning, alert the operator, and unmute its speaker (to receive a message). If there is no activity for a preset time (Twa), the station shall automatically mute its speaker and return to scan. To minimize possible adverse effects resulting from overuse or abuse of allcalls, stations shall have the capability to disable receipt of the allcall. Normally the allcall should be enabled. If the allcall is successfully received with a THIS WAS, the called station shall automatically resume scanning and will not respond (unless otherwise directed by the operator or controller). If multichannel calling is used, at the end of the allcall transmission on a channel, the caller shall use call acceptance (THIS IS, with a pause) or call rejection (THIS WAS) protocols identical to the sounding (scanning) protocols in 70.5. If an allcalled or receiving station desires to attempt to link (within the pause after THIS IS), it shall use the optional handshake protocol in 70.5.4. In all handshakes (other than the calling cycle of the initial allcall), the allcall address shall not be used.

## MIL-STD-188-141A

## APPENDIX A

As an additional procedure, the calling station shall have the optional capability to organize (or divide) the available but unspecified receiving stations into logical subsets, using the selective allcall protocol. The selective allcall is identical in structure, function, and protocol to the allcall except that it specifies the last single character of the addresses of the desired subgroup of receiving stations (1/36 of all). By replacing the "?" with an alphanumeric, the selective allcall special address pattern shall be "TO @A@" in Tsc and Tlc (or possibly "THRU @A@" and "REPEAT @B@" in Tsc, and then TO and REPEAT in Tlc if more than one subset is also desired), and rotated if necessary. "A" (and "B", if applicable) in this notation represents any alphanumeric of the basic 38 subset characters (except "@" or "?"). "A" and "B" may represent the same or different character from the subset, and specifically indicate which character(s) must be last in a station's address in order to stop scan and listen. As an example of proper usage, a selective allcall to all stations ending in "P", "Q", and "R", (3/36 of all) would be structured "THRU @P@", "REPEAT @Q@", "THRU @R@", "REPEAT @P@", until appropriately long for the Tsc scan call (and finish with TO, REPEAT, TO... in Tlc). As in the global allcall, the scanning and optional procedure are the same as for the sounding scanning protocol.

60.5.4.4 Anycalls. An ALE station may call, and receive responses from, essentially unspecified stations, and it thereby can identify new stations and connectivities. An "anycall" is a general broadcast which requests responses without designating any specific addressee(s). It is required for emergencies, reconstitution of systems, and creation of new networks. See table A-X. If an ALE station requires an anycall type function, it shall use the following anycall protocols. The anycall special address structures shall be the exclusive members of the calling cycle in the initial call, shall not be used in any other address field or part of the handshake, and shall use the TO the entire Tcc. The global anycall special address pattern shall be "TO @@?", and repeated if necessary for scanning. Upon receipt of the anycall (and unless inhibited or otherwise directed by the operator or controller), all receiving anycalled stations shall temporarily stop their scan, and examine the call identically to the procedure for allcalls in 60.5.4.4, including the Tcc max, Tm max, and Tx max limits. If the anycall is successfully received, the station shall automatically perform a slotted response identical to that for a star net (scanning) call protocol (70.6.2), but as modified below.

There shall be seventeen standardized slots (slot 0 plus sixteen) each 20 Tw (2613.33... ms) wide, for a total duration of approximately 44 seconds. As is described in 70.6, the primary general variation to slot size is with LQA. If the calling station requests LQA in the message ( ▽ ), the responses shall expand by 3 Tw to include the LQA ( ▼ ), and the slots shall automatically expand by 3 Tw to 23 Tw (3005.33... ms), for a total of approximately 51 seconds. In either anycall case, each responding station shall individually select a slot (of one through sixteen, but not zero unless emergency), essentially pseudorandomly (PRN), to transmit its response in. In this protocol, collisions are expected and tolerated, and the caller attempts to read the best response in each slot. Responses shall be standard star net (or individual call) responses consisting of TO (with the address of the caller) and THIS IS (with the address of the responder), with the LQA



## MIL-STD-188-141A

## APPENDIX A

included if requested, and shall not use the anycall special address. The caller should use a short one-word self address and shall not use more than three words. The responders shall use a self address no longer than four words minus the caller address length. (For example, if the caller address is two words, the responder cannot exceed two words.) Upon receipt of the slotted responses, the calling station shall transmit the acknowledgement (ACK) to any selected combination (individual or group call) of stations which responded and were read. The responders which receive acknowledgements shall alert, unmute their speakers, and shall pause for traffic, (or quit immediately), as indicated by the caller's ACK conclusion THIS IS (or THIS WAS, respectively). The caller shall not use the anycall special address in the ACK. The caller may pause for additional interoperation and traffic (THIS IS) with the responders; or may immediately resume scanning calling on the next channel (THIS WAS); or try again, as appropriate to the caller's original purpose. Any responding stations that are not included in the ACK shall immediately depart and resume scan. If the anycall is successfully received with a THIS IS, the called station shall stop scan, alert the operator and unmute its speaker (to receive a message). If there is no activity for a preset time (Twa), the station shall automatically mute its speaker and return to scan. To minimize possible adverse effects resulting from overuse or abuse of anycalls, stations shall have the capability to disable receipt of the anycall. Normally the anycall should be enabled.

If too many responses are received, or if the caller must organize the available but unspecified responders into logical subsets, the selective anycall protocol shall be used. The selective anycall is a selective general broadcast which is identical in structure, function, and protocol to the global anycall, except that it specifies the last single character of the addresses of the desired subset of receiving stations (1/36 of all). By replacing the "?" with an alphanumeric, the global anycall becomes a selective anycall whose special address pattern shall be "TO @@A" in Tcc. If a group call (multiple selective anycall), the THRU @@A and REPEAT @@B... are used alternately in the scan call (Tsc), and then TO @@A and REPEAT @@B... in the leading call (Tlc), and rotated if necessary. "A" (and "B", if applicable) in this notation represents any alphanumeric of the basic 38 subset characters (except "@" or "?"). "A" and "B" may represent the same or different characters from the subset, and specifically indicate which character(s) must be last in a station's address in order to initiate a response. As an example of proper usage, a selective anycall to all stations ending in "P", "Q", and "R" (3/36 of all) would be structured "TO @@P", "REPEAT @@Q", "TO @@R", "REPEAT @@P", until appropriately long for the calling cycle.

NOTE: If a narrower acceptance and response criteria is required, the double selective anycall should be used. The double selective anycall is an operator selected general broadcast which is identical to the selective anycall described above, except that its special address (using "@AB" format) specifies the last two characters that the desired subset of receiving stations must have to initiate a response. See table A-X.

## MIL-STD-188-141A

## APPENDIX A

60.5.4.5 Wildcards. A "wildcard" is a special character which the caller uses to address multiple-station addresses with a single-call address. The receivers shall accept the wildcard character as a substitute for any alphanumeric in their self addresses in that same position or positions. Therefore, each wildcard character shall substitute for any of 36 characters (A to Z, 0 to 9) in the basic 38-character subset. The total lengths of the calling (wildcard) address, and the called addresses shall be the same. The special wildcard character shall be "?" (0111111). It shall substitute for any alphanumeric in the basic 38-character subset. It shall substitute for only a single-address character position in an address, per wildcard character. See table A-XI for examples of acceptable patterns.

Wildcard addresses shall be the exclusive members of the initial call's calling cycle, and shall not be used in any other address sequence in the ALE frame or handshake. The span (number of cases possible) of the wildcard(s) used should be minimized to only the essential needs of the user(s). The basic address wildcards, when followed with a THIS WAS terminator, shall cause no responses and shall be otherwise identical to the allcall protocol in 60.5.4.3. The address wildcards, when followed with a THIS IS terminator, shall cause responses in pseudorandomly-selected slots, and shall use the protocol otherwise identical to the anycall in 60.5.4.4. As in both the allcall and anycall, stations shall have the capability to allow the operator or controller to disable acceptance. Acceptance should normally be enabled.

60.5.4.6 Self address. For self test, maintenance, and other purposes, stations shall be capable of using their own self addresses in calls. When a self-addressing type function is required, ALE stations shall use the following self-addressing structures and protocols. Any ALE calling structures and protocols permissible within this standard, and containing a specifically addressed calling cycle (such as "TO ABC", but not allcall or anycall), shall be acceptable, except that the station may substitute (or add) any one (or several) of its own calling addresses into the calling cycle. A full-duplex station shall be capable of calling and handshaking with itself.

60.5.4.7 Null address. For test, maintenance, buffer times, and other purposes, the station shall use a null address which is not directed to, accepted by, or responded to by any station. When an ALE station requires a null address type function, it shall use the following null address protocol. The null address special address pattern shall be "TO @@@", (or REPEAT @@@"), if directly after another TO. The null address shall only use the TO (or REPEAT), and only in the calling cycle (Tcc). Null addresses may be mixed with other addresses (group call), in which case they shall appear only in the leading call (Tlc), and not in the scanning call (Tsc). Nulls shall never be used in the conclusion (terminator) (THIS IS or THIS WAS). If a null address appears in a group call, no station is designated to respond in the associated slot; therefore, it remains empty (and may be used as a buffer for tuneups, or overflow from the previous slot's responder, etc.).

## MIL-STD-188-141A

## APPENDIX A

TABLE A-XI. Use of "?" wildcard symbol.

A B C		BASIC "STANDARD", 1 CASE EACH	
A B ?	A ? C	? B C	"STANDARD""WILD-1", 36 CASES EACH
A ? ?	? B ?	? ? C	"STANDARD""WILD-2", 1296 CASES EACH
? ? ?			"STANDARD""WILD-3", 46656 CASES EACH
A B @			"STUFF-1", 1 CASE EACH
A ? @	? B @		"WILD-1""STUFF-1", 36 CASES EACH
? ? @			"WILD-2""STUFF-1", 1296 CASES EACH
A @ @			"STUFF-2", 1 CASE EACH
? @ @			"WILD-1""STUFF-2", 36 CASES EACH
@ A B			"DOUBLE SELECTIVE ANYCALL", ("DSA") 1/1296 CASES
@ A ?			"DSA""WILD-1", 1/36 CASES
@ ? B			NOT PERMITTED. USE "SELECTIVE ANYCALL"
@ ? ?			NOT PERMITTED. USE "GLOBAL ANYCALL"
@ @ A			"SELECTIVE ANYCALL"
@ @ ?			"GLOBAL ANYCALL"
@ A @			"SELECTIVE ALL CALL"
@ ? @			"GLOBAL ALL CALL"

## MIL-STD-188-141A

## APPENDIX A

60.6 Link quality analysis (LQA).

60.6.1 General. LQA concerns the automatic measurement of the quality of the ALE signal on the link(s) between station(s). The resultant LQA data is used to score the channels and to support selection of a "best" (or an acceptable) channel for calling and communication. See 60.7. LQA shall also be used for continual monitoring of the link(s) quality during communications which use ALE signaling. The stored values shall be available to be transmitted upon request, or as the network manager shall direct. Unless specifically and otherwise directed by the operator or controller, all ALE stations shall automatically insert the COMMAND LQA word (▼) in the message section of their signals and handshakes when requested by the handshaking station(s), when prearranged in a network, or when specified by the protocol. See 80.2. If an ALE station requires, and is capable of using LQA information (polling-capable), it may request the data from another station by setting the control bit KAI to "1" in the COMMAND LQA word. If an ALE station which is sending a COMMAND LQA in response to a request is incapable of using such information itself (not polling-capable), it shall set the control bit KAI to "0". It will be a network management decision to determine if the LQA is to be active or passive. For human factor considerations, LQA scores which may be presented to the operator should have higher (number) scores for better channels.

60.6.2 Basic bit error ratio (BER). The ALE system essentially performs a "pass/fail" LQA test on every received signal by its critical examination of proper coding, structure, and format. Within its integral demodulation and decoding functions is an inherent basic BER measurement capability. The purpose of the basic BER/LQA measurement described herein is to obtain an additional assessment of link quality which provides more resolution than available with the absolute "pass/fail" approach. The BER/LQA function uses data obtained in the process of decoding the received words used in the automatic linking process.

Analysis of the BER on rf channels, with respect to poor channels and the 8-ary modulation, plus the design and use of both redundancy and Golay FEC, shows that an excellent and proportional measure of BER may be obtained by counting the number of 2/3 votes (out of 48) in the majority vote decoder. The BER values should be represented internally by a number which shall range from 0(000000) to 48(110000). The BER/LQA measurement is based on each redundant triplet (3 Tw) word which is received and properly decoded as a valid majority word. Therefore, in an ALE transmission, the best BER/LQA value should appear when the majority vote decoder is properly aligned with the incoming signal; that is, all three-word inputs are occupied with identical (except for errors) redundant words.

The BER may vary during an ALE transmission, and a linearly averaged BER/LQA, which includes all the measurements on good words which were properly aligned, shall be used. If a badly received word is unreadable and is rejected, it shall be assigned the worst BER/LQA value 48(110000) and averaged.

## MIL-STD-188-141A

## APPENDIX A

All ALE stations shall automatically perform the basic BER/LQA algorithm on all received ALE signals based on majority decoder voting. The individual word internal BER/LQA values shall be directly derived from the number of 2/3 majority votes for a particular triple redundant word, properly aligned. The value for an entire received signal shall be the linear average of the internal BER/LQA values of the valid received words, shall include a worst-case 48(110000) value for rejected words, and shall be for an entire and uninterrupted signal. For transmission in the COMMAND LQA word, the internal average value shall be converted to five-bit values as shown in table A-XII. The five-bit values, BE5 (MSB) through BE1 (LSB), shall be the binary representation of the average number of counted (or averaged) 2/3 votes.

60.6.3 Signal plus noise plus distortion to noise plus distortion ratio (SINAD). The optional signal to noise and distortion measurement employed within the LQA shall be a SINAD measurement  $((S+N+D)/(N+D))$  averaged over the duration of the received ALE signal. If implemented, the SINAD values shall be measured on all ALE signals and shall be inserted into all LQA words in the same manner as the BER. It shall be communicated in 4-bit values as shown in 80.2.2.

60.6.4 Multipath (MP). MP measurements are reserved until standardized.

#### 60.7 Channel selection.

60.7.1 General. Channel selection concerns the automatic identification of a (recently) best (or acceptable) channel for initiating calls or broadcasts to one or several stations. The selection is based on the information stored within the LQA memory (such as BER, SINAD, and MP) and this information is used to speed connectivity and to optimize the choice of quality channels. The ranking and selection method should depend on the quality of information available, the type(s) of link(s) required (1-or 2-way, voice or data), and the quantity of stations involved. The manufacturer should select method(s) for optimum performance.

When initiating scanning (multichannel) calling attempts, the sequence of channels to be tried shall be derived from information in the LQA memory with the channel(s) with the "best score(s)" being tried first (unless otherwise directed by the operator or controller) until all the LQA scored channels are tried. However, if such information is unavailable (or it has been exhausted and other valid channels remain available and untried) the station shall start (or continue) on the highest frequency (untried valid) channel, and if unsuccessful shall continue with the next highest (untried valid) channel, until successful or until all the remaining (untried valid) channels have been tried.

60.7.2 Single-station channel selection. The station shall be capable of selecting the (recent) best channel to initiate a call to, or seek a single station, based on the values in the LQA memory. Figure A-19 represents a simple LQA memory example. For each address/channel call, the received LQA (upper section) and reported LQA values (lower section) are stored. Bilateral (handshake) scores in this example are the sum of the two LQA values.

## MIL-STD-188-141A

## APPENDIX A

TABLE A-XII. Basic bit-error-ratio (BER) values.

Average 2/3 votes counted	LQA transmission bits					Approx. BER
	MSB BE5	BE4	BE3	BE2	LSB BE1	
0	0	0	0	0	0	0.0
1	0	0	0	0	1	0.006993
2	0	0	0	1	0	0.01409
3	0	0	0	1	1	0.02129
4	0	0	1	0	0	0.02860
5	0	0	1	0	1	0.03602
6	0	0	1	1	0	0.04356
7	0	0	1	1	1	0.05124
8	0	1	0	0	0	0.05904
9	0	1	0	0	1	0.06699
10	0	1	0	1	0	0.07508
11	0	1	0	1	1	0.08333
12	0	1	1	0	0	0.09175
13	0	1	1	0	1	0.1003
14	0	1	1	1	0	0.1091
15	0	1	1	1	1	0.1181
16	1	0	0	0	0	0.1273
17	1	0	0	0	1	0.1368
18	1	0	0	1	0	0.1464
19	1	0	0	1	1	0.1564
20	1	0	1	0	0	0.1667
21	1	0	1	0	1	0.1773
22	1	0	1	1	0	0.1882
23	1	0	1	1	1	0.1995
24	1	1	0	0	0	0.2113
25	1	1	0	0	1	0.2236
26	1	1	0	1	0	0.2365
27	1	1	0	1	1	0.2500
28	1	1	1	0	0	0.2643
29	1	1	1	0	1	0.2795
30	1	1	1	1	0	0.3
--	1	1	1	1	1	no value available

## NOTES:

1. BER calculated statistically from probability of number of 2/3 votes of 48.
2. The 2/3 votes count is the average of 2/3 votes of 48 over the words in the received signal.

## MIL-STD-188-141A

## APPENDIX A

		CHANNELS							
		C1	C2	C3	C4	C5	C6		
ADDRESSES (OTHER STATIONS)	A	FROM	10	4	1	0	5	15	
		TO	14	8	2	x	7	11	
	B	FROM	9	5	1	3	2	6	
		TO	x	7	4	3	5	12	
	C	FROM	30	22	13	8	3	18	
		TO	x	-	17	6	2	-	
	D	FROM	1	2	5	12	20	-	
		TO	-	4	7	15	21	-	
	E	FROM	-	2	6	7	10	-	
		TO	x	14	6	9	12	x	

## LQA SCORES

**NOTES:**

1. UPPER VALUE IS LQA MEASUREMENT ON RECEIVED SIGNAL FROM OTHER STATION.
2. LOWER VALUE IS LQA MEASUREMENT ON TRANSMITTED SIGNAL TO OTHER STATION AS RECEIVED AND REPORTED BACK.
3. EXAMPLE SHOWS RANGE OF 0 TO 30 FOR LQA "SCORES", WITH SMALLER VALUE BEING BETTER.
  - LQA = "0" IS EXCELLENT, RANGING DOWN TO "30" WHICH IS VERY POOR.
  - LQA = "X" INDICATES NONE AVAILABLE AFTER HANDSHAKE ATTEMPT.
  - LQA = "-" INDICATES NONE AVAILABLE BUT HANDSHAKE NOT TRIED.

FIGURE A-19. LQA memory example.



## MIL-STD-188-141A

## APPENDIX A

NOTE 1: For operator viewing, LQA values for better channels should be displayed as higher numbers, and values for poorer channels should be displayed as lower numbers.

NOTE 2: In the example shown on figure A-19, if a handshake is required with station B, channel C3 would be best because the "round trip" (bilateral) score would be 5 (1+4), thus the lowest. Channel C4 is next best with a score of 6 (3+3), then C5 with 7, C2 with 12, and C6 with 18. Linking attempts should be made in that order (C3, C4, C5, C2, and C6). C1 is left until last because of the "x" which indicates that a recent attempted handshake on that channel failed to link.

Similarly, an attempt to call A would yield the sequence C3(3), C5(12), C2(12), C1(24), C6(26), and C4(x). In this case, C5 was equal to C2 (both were 12), but C5 was chosen first because the paths were more balanced (LQA values were more equal).

If a broadcast is required (instead of a handshake), only the lower section ("to" the station) scores are used.

NOTE: In the example, to reach B, the sequence would be C4(3), C3(4), C5(5), C2(7), C6(12), and C1(x) as a last resort.

If a "listening for" or a seeking of a station is desired, only the upper section ("from" the station) scores are used.

NOTE: In the example, to listen for A, channel C4(0) would be best, and if only three channels were to be scanned, they should be C4, C3, and C2.

60.7.3 Multiple-station channel selection. The station shall be capable of selecting the (recent) best channel to initiate a call to, (or seek) multiple stations, based on the BER values in the LQA memory.

NOTE: In the example shown on figure A-19, if a star net or group handshake is required with stations B and C, C5 is the best choice as the total score is 12 (2+5+3+2), followed by C4(20) and C3(35). Next would be C2 (34+) and C6 (36+), this ranking being due to their unknown handshake capability (which had not been tried). C1(x) is the last to be tried because recent handshake attempts had failed for both B and C. To call the three stations A, B, and C, the sequence would be C5(24), C3(38), C2(46+), C6(62+), C4(one x) (recently failed attempt), and finally C1(two x).

If an additional selection factor is used, it will change the channel selection sequence.



MIL-STD-188-141A

APPENDIX A

NOTE: In the example, to call D and E, the sequence would be C2, C3, C4, C5, C1, and C6. If a maximum limit of LQA  $\leq 14$  is imposed on any path (to achieve a minimum circuit quality), only C2 and C3 would be initially selected for the linking attempt. Further, if the LQA limit was "lowered" to 10, C3 would be selected before C2 for the linking attempt.

If a broadcast to multiple stations is required, only the lower section ("to the station) scores are used.

NOTE: In the example, to broadcast to B and C, the sequence would be C5(7), C4(9), C3(21), C2(7+), C6(12+), and C1(two x).

If a seeking of multiple stations is required, only the upper section ("from the station) scores are used.

NOTE: In the example, to listen for A and B, channel C2(2) would be best, and if only four channels could be scanned, they should be C2, C3, C4, and C5.

## MIL-STD-188-141A

## APPENDIX A

## 70. PROTOCOLS.

70.1 Introduction. In addition to the waveform and signal structure, the ALE system provides specific protocols, or clearly defined rules for interaction among stations, to implement the necessary automated functions. This section presents the protocols for manual and automatic operation on single and multiple channels, with individual and multiple stations, and for both linking and networking.

70.2 Manual operation. The system is based on standard HF SSB radios, essentially all of which are manually controllable. However, these radios must also be controllable by the ALE controller if the benefits of automation are to be achieved. An ALE station consists of an ALE controller, a controllable SSB radio, and support (antennas, power, etc.). Through the ALE controller, the system enables compatible control by both operators and automation. Two specific manual operations are described below: emergency control by the operator, and push-to-talk operation.

70.2.1 Operator control. Each station shall be equipped with a manual control capability to permit a human operator to directly operate the basic SSB radio in emergency situations. At all other times, the radio shall be under automated control, and the human operator should operate the radio through its associated controller. In either case, the ALE controller's receiving and passive collection capabilities ("always listening"), such as monitoring for sounding signals or alerting the operator, shall not be impaired.

70.2.2 Push-to-talk operation. Push-to-talk (PTT) operation is the most common form of human interaction with MF/HF SSB radios, especially for tactical use by minimally trained, "noncommunicator" operators. Manual control with PTT shall be conventional; that is, the operator pushes the PTT button to talk and releases it to listen.

70.3 ALE operational rules. The ALE system shall incorporate the basic operational rules listed in table A-XIII. "Always listening" (rule 2) is not required during temporary periods when not technically possible, such as during transmit with a transceiver or when using a separate transmitter and receiver with a common antenna.

70.4 Individual calling.

70.4.1 Introduction. The essential element of the ALE protocols is the basic call structure, which is based on the waveform, timing, and coding structures discussed in previous sections. This basic presentation format, shown on figure A-20, is used in all the ALE protocol illustrations in this standard. Time is approximately to scale and moves from left to right. The timing symbols are defined in Annex B and their computation is described in 70.4.4. The footnotes, such as (2) for tuning time, are essentially standardized throughout, except for occasional minor variations to clarify each specific protocol. Each "box," such as "THIS IS A", indicates an individual, on-the-air, 130.66... ms nonredundant word ( $T_w$ ), of which several duplicates (multiples of 3) are used to communicate them as redundant words

## MIL-STD-188-141A

## APPENDIX A

TABLE A-XIII. ALE operational rules.

- |                                                                                                                                                                                                                                                                                                                                                                                                                                                                                                                                                                                                                                                                                                                                                                                                                                                                                                                        |
|------------------------------------------------------------------------------------------------------------------------------------------------------------------------------------------------------------------------------------------------------------------------------------------------------------------------------------------------------------------------------------------------------------------------------------------------------------------------------------------------------------------------------------------------------------------------------------------------------------------------------------------------------------------------------------------------------------------------------------------------------------------------------------------------------------------------------------------------------------------------------------------------------------------------|
| <ol style="list-style-type: none"> <li>1) Independent ALE receive capability (in parallel with any others) (critical).</li> <li>2) Always listening (for ALE signals) (critical).</li> <li>3) Always will respond (unless deliberately inhibited).</li> <li>4) Always scanning (if not otherwise in use).</li> <li>5) Will not interfere with active ALE channel (unless priority or forced).</li> <li>6) Always will exchange LQA with other stations when requested (unless inhibited), and always measures the signal quality of others.</li> <li>7) Will respond in preset/derived/directed time slot (net/group/special calls).</li> <li>8) Always seek (unless inhibited) and maintain track of their connectivities with others.</li> <li>9) Linking ALE stations employ highest mutual level of capability.</li> <li>10) Minimizes time on channel.</li> <li>11) Minimizes power used (as capable).</li> </ol> |
|------------------------------------------------------------------------------------------------------------------------------------------------------------------------------------------------------------------------------------------------------------------------------------------------------------------------------------------------------------------------------------------------------------------------------------------------------------------------------------------------------------------------------------------------------------------------------------------------------------------------------------------------------------------------------------------------------------------------------------------------------------------------------------------------------------------------------------------------------------------------------------------------------------------------|

NOTE: Listed in order of precedence.

(Trw), as shown (usually as boxes with "tic" marks). In this example, the basic required minimum call, which is 3 Trw (1176 ms) long, is shown. The large letters, such as "A" and "B", are convenient graphic substitutes for the actual three characters of the basic address field. The delta ( $\nabla$ ) indicates the location of the optional message section, where COMMAND (and DATA and REPEAT) may be inserted (with a consequent time increase of Trw (392 ms) per original, nonredundant word). The initiation of the outgoing frame shall always be after the transmitter is up to full power (over 90 percent) and shall be word synchronized in accordance with 60.4.3.1. Described below are both single-channel and multiple-channel protocols, plus detailed timing, control, and message information for designing ALE stations. The single-channel description is also an overview of the linking. The multiple-channel description provides an in-depth analysis of the individual protocols.



## MIL-STD-188-141A

## APPENDIX A

70.4.2 Single channel. The fundamental capability to automatically link on a channel is provided by the individual calling protocol. This protocol establishes and positively confirms bilateral connectivity between stations on a channel. ALE stations shall employ this protocol for single-channel linking, polling, and networking, and for basic automated ALE interoperation on a channel after scanning linking. All ALE stations, when operational and not otherwise committed, shall continually listen for calls; that is, they are "always available." See figure A-2i. The protocol consists of three parts: an individual call, a response, and an acknowledgement. At the left, in this one-channel example (1), the caller A should already be properly tuned to the channel (2). The wait buffer (3) provides a listen-before-transmit pause, to avoid "disturbing active channels." It has an optional length (Twt) because, in the single channel case, the history of channel activity (and present occupancy) is generally known. Similarly, there is generally no need for an extended calling cycle (4), although it may provide increased probability of signal detection and call receipt. If a fixed station is trying to contact a scanning station, or does not know if the called station is scanning, it should use the totally compatible individual scanning calling protocol. Normally, both A and B are on channel and available; that is, their speakers are muted, they are "always listening", and they "will respond when called." Starting with the individual call, station A shall call station B by transmitting a calling cycle containing B's address ("TO B"), followed by a conclusion (terminator) containing his own ("THIS IS A") (7). A then shall wait a preset reply time (Twr, a buffer which includes anticipated propagation each way and B's turnaround time) to start to receive B's response (9). Upon receipt of A's call and recognition of both his and A's addresses, B shall tune up (if needed) (2), send the response, and wait his own reply time Twr. Upon receipt of B's response (starting within the reply wait Twr), and recognition of both his and B's addresses, A shall send the acknowledgement, unmute his speaker, and alert his operator. Upon receipt of the acknowledgement (starting within B's reply time Twr), B shall also alert his own operator and unmute his speaker. The operators may then pick up their microphones and exchange conventional PTT voice communication, radio teletypewriter (RTTY), ICW, or anything else required. When they are through, they may reset the stations (mute the speakers), therefore restoring them to ALE "available." If an operator or controller does not key the PTT or use the station within a preset time limit for activity (Twa), the station shall automatically mute and return to "available." Also, if the expected reply does not start to arrive within the preset wait time (Twr), the handshake shall be terminated, but it may be reinitiated by the operator or controller. Termination of a handshake or protocol by a timer (or by the use of THIS WAS) shall cause the timed (or receiving) station to end the handshake or protocol, remute, and immediately resume scanning (if multichannel).

There are several specific variations to the protocol. If an automated message (or COMMAND sequence) is to be sent in any of the signals, it shall be inserted at the (▼) delta location (5), and the signal frame will be appropriately lengthened. The message can provide many options, such as the insertion of LQA information at (▼), and it may significantly affect the protocol and timing, as described in section 80. Normally, A's use of "THIS IS" in the call compels B's response, and the substitution of a "THIS WAS"

MIL-STD-188-141A

APPENDIX A

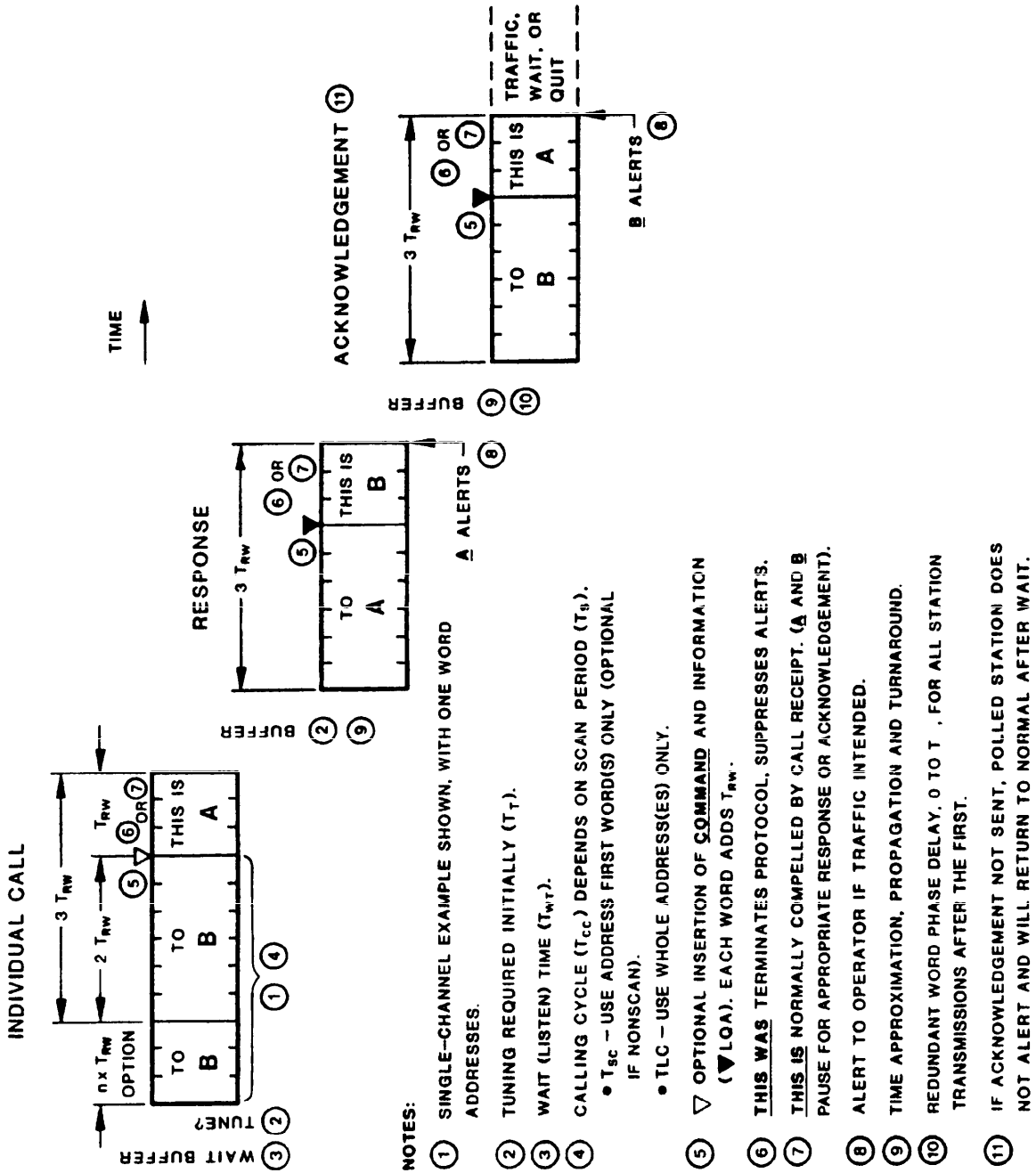

FIGURE A-21. Individual call protocol.

## MIL-STD-188-141A

## APPENDIX A

shall suppress B's response (6) and terminate the protocol. Therefore, if the individual call contained "THIS WAS A," B would receive A's call (and the message, if any), realize that it was a one-way broadcast for B, and B would not respond (unless otherwise compelled by the message, his operator, or his controller). Similarly, B's use of "THIS IS" compels A to complete the handshake and send an acknowledgement. However, if B sends a "THIS WAS," A shall not alert or send an acknowledgement, and the protocol shall be terminated. A station such as B would terminate the handshake under several circumstances, such as being unavailable (but active), being engaged in traffic, realizing that the channel is busy (at B's end), or being compelled (by prearrangement or protocol) to respond without having an obligation to continue (mandatory roll call, optional chat).

It should be noted that A's acknowledgement to B appears identical to A's individual call to B, but it does not cause B to provide another response to the acknowledgement (resulting in an endless "ping-pong" handshake) because A's acknowledgement arrives within the narrow time window ( $T_{wr}$ ) of B's first response, and A is responsible for sending the ACK within this time limit. If A does not receive B's response within this preset time, the call is considered unsuccessful and A may terminate, or A may try again with additional call attempts (preset, controller, or operator choice). If A's acknowledgement arrives late (after  $T_{wr}$ ), then B treats it as a new (or second) individual call (and provides a new response, if A uses THIS IS).

While receiving an ALE signal, it is possible for the continuity of the received signal to be lost (due to such factors as interference or fading) as indicated by failure to periodically ( $T_{rw}$ ) detect good ALE words. If such a dropout occurs during an initial received call, and continues for a period in excess of 3  $T_{rw}$  (1176ms) beyond the last good received words without detection of additional good received words, the receiving stations shall abandon the attempt to link and, if multichannel, shall immediately return to normal receive scanning. In all cases each individual ALE received signal must have all of its included words at a consistent and uniform redundant word phase, despite dropouts, to be acceptable and valid. Any variation indicates an interference or a collision and such variation shall be rejected as not part of the signal.

NOTE: Stations should be able to read interfacing ALE signals, as they may contain useful (or critical) information, and the station is therefore "always listening".

Also, if a station receives a complete individual call (TO with the whole address), but does not receive the expected conclusion (THIS IS or THIS WAS), it should attempt a single-channel call acceptance sound (THIS IS, as described in 70.5.4) to reinitiate the calling station.



## MIL-STD-188-141A

## APPENDIX A

70.4.3 Multiple channels. All ALE stations shall be capable of performing the individual scanning calling protocol described herein, even if on a fixed frequency. See figure A-22. If multichannel, they should be "always scanning." This protocol establishes and positively confirms bilateral connectivity between stations on any available mutually scanned channel. Stations shall employ this protocol for multichannel linking. This protocol is fully compatible with the previously described individual calling protocol shown on figure A-21, and is essentially identical except for the longer calling cycle and the following modifications.

All stations, when operational and not otherwise committed, shall continually scan a preselected set of channels, or "scan set," listening for calls and ready to respond. The minimum dwell time ( $T_{d \min}$ ) on each channel is the reciprocal of the scan rate, and the channels in the scan set are repeatedly scanned in the same order and for the same period. This minimum scan period ( $T_{s \min}$ ) is equal to the product of the number of channels ( $C$ ) times the minimum dwell time on each channel ( $T_{d \min}$ ); that is,  $T_{s \min} = C \times T_{d \min}$ . However, the receive scan period ( $T_s$ ) (for calling transmit ( $T_{sc}$ ) computations) should be based on the probable maximum pause ( $T_d$ ) to read words on each channel, or  $T_{drw} = 784$  ms. Thus,  $T_s = C \times T_d = C \times 784$  ms. The net manager may adjust the  $T_d$  to optimize system performance.

All stations, when attempting to contact another station in a multichannel environment, shall scan through the preselected set of channels, pausing on each channel of the set to transmit an individual scanning call, and waiting for a preset, limited time for responses. The calling cycle ( $T_{cc}$ ) is composed of a scan calling time ( $T_{sc}$ ) plus a leading call time ( $T_{lc}$ ). The scan calling time ( $T_{sc}$ ), in order to capture the scanning receiver, must equal or exceed the total scan period ( $T_s$ ) of the called station and shall also be composed of multiple address first words ( $\sum T_{a1} = T_{c1}$ ), which are a multiple of the redundant word time,  $T_{rw}$ ; that is,  $T_{sc} = n \times \sum T_{a1} = n \times T_{c1} \geq T_s$ . The scanning call contains only the called address(es) different first words ( $\sum T_{a1}$ ) in rotation. The leading call contains only the whole called station(s) address(es), repeated twice ( $2T_c = 2 \sum T_a$ ). Therefore, the calling cycle should be:  $T_{cc} = T_{sc} + T_{lc} = (n \times \sum T_{a1}) + 2T_c \geq T_s + 2(\sum T_a)$ . The relative timing of the receive and transmit scan cycles shall ensure that the scanning receiver samples the entire channel scan set within the period of a scanning call.

The scanning calling station shall stop and link on the first channel which supports the handshake with the called station(s). After scan stop, unmute, and operator alert, the operators (or controllers) use the link and the channel as necessary. If they reject it as unsuitable, they may restart the scan sequence to seek another, better channel by muting (resetting) their stations and reinitiating scanning calling (usually by the original caller). If the calling station has an LQA memory and scoring capability it shall rerank the channels (with the rejected and the previously failed channels being downgraded) and restart the calling on the newly expected best channel. If the station has a fixed calling channel sequence, it shall restart the scanning call on the next channel which would have been tried



MIL-STD-188-141A

APPENDIX A

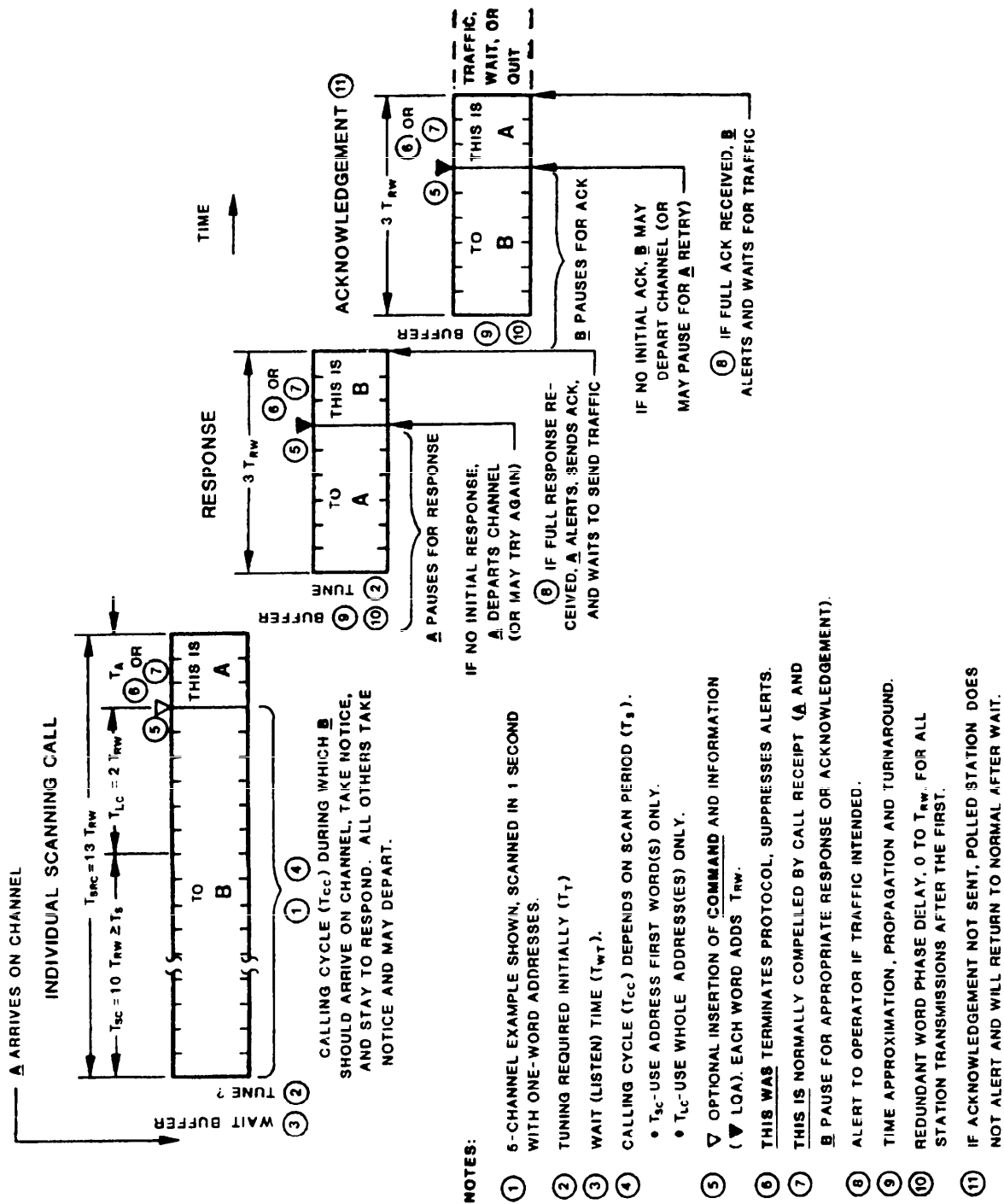

FIGURE A-22. Individual scanning calling protocol.

## MIL-STD-188-141A

## APPENDIX A

earlier had a link not been established, and it does not restart at the top frequency (or first channel) as before (unless directed by operator or controller). Often during the scanning calling cycle, the caller will encounter occupied channels which are skipped to avoid interference to traffic and activity. After all available channels have been tried, and no contact has been successful, the caller may optionally revisit the previously occupied channels and, if they are free, attempt to call. In either case, when the calling station has exhausted all the prearranged scan set channels and failed to establish a link, it shall immediately return to normal receive scanning. It shall also alert the operator (and controller) that the calling attempt was unsuccessful. If the scanning call is reinitiated, the ALE station shall restart and try again. Refer to 70.4.4 for the specific details of ALE timing.

When an appropriately addressed call ("TO B") is detected by, and addressed to, scanning station B, the station shall stop (for a preset, limited time) to read the rest of the signal and to perform the standard handshake (unless otherwise directed) with the calling station (A). If the call is not addressed to station B, B shall leave the channel immediately and resume scanning (unless otherwise directed by the selected protocol, or its operator or controller). Figure A-22 illustrates the individual scanning calling protocol handshake for stations in a typical five-channel network and employing a standard scan rate of five chps. The protocol starts with A's arrival on channel, shown at the left. Upon arrival, A shall pause for a preset buffer time ( $T_{wt}$ ) to monitor the channel and listen for traffic or occupancy (3). If the channel appears clear (or if A is forced by the operator or controller), A shall tune its coupler (2) as rapidly as possible ( $T_t$ ), and initiate the transmission. The scan calling time ( $T_{sc}$ ) of the calling cycle ( $T_{cc}$ ) is deliberately longer than B's scan period ( $T_s$ ) to ensure that B will be "captured" as it scans to, and samples, the channel.

When station B arrives on channel, sometime during its scan period ( $T_s$ ), and therefore during A's additional and longer scan calling time ( $T_{sc}$ ), B shall attempt to detect ALE signaling (within dwell time  $T_{d\ min}$ ) and then shall decide to wait a preset time ( $T_{drw}$ ) to read possible ALE words if ALE signaling was detected. If no signaling is detected within  $T_{d\ min}$ , B shall resume scanning. If non-ALE signaling or interference is detected, B shall resume scanning.

If B does not read appropriate ALE words within  $T_{drw}$ , B shall leave and resume scanning. If B reads "TO B" (or an acceptable equivalent according to protocols), it shall stop scan, plan to reply (response), and wait a preset, limited time ( $T_{wce}$ ) for the calling cycle to end and the message or conclusion to begin. Meanwhile, B shall continually read the ALE signaling to identify additional information, such as type of call (and additional station addresses if any). B shall attempt to detect invalid sequences, in which case B shall automatically reject the call and immediately resume scan (unless otherwise directed by the operator or controller). If a quick-ID or a message (COMMAND sequence) starts within  $T_{wce}$ , B shall wait and attempt to read the message within a new preset, limited time ( $T_{m\ max}$ ). If no quick-ID or message starts within  $T_{wce}$ , or no terminator starts within  $T_{m\ max}$  (or  $T_{wce}$

## MIL-STD-188-141A

## APPENDIX A

if no message), B shall resume scan. If an invalid message sequence is read, B shall resume scan immediately. If a terminator starts, such as "THIS IS A", B shall wait and attempt to read the calling station's address (A) within a new preset, limited time ( $T_x \text{ max}$ ). If an unacceptable terminator address sequence is read, B shall resume scan immediately. If an acceptable terminator sequence with THIS IS is read, B shall wait to respond (while identifying the entire address). B shall also expect A to continue the handshake (with an acknowledgement) within B's reply window,  $T_{wr}$ , after B's response. If THIS WAS is read instead, B shall not respond and shall resume scan immediately (after identifying the entire address).

All receiving stations shall identify the end of a received ALE signal by the following methods. The station shall search for a valid terminator (THIS IS or THIS WAS, possibly followed by DATA and REPEAT for a maximum of five words, or  $T_x \text{ max}$ ). The terminator shall maintain constant redundant word phase within itself (if a sound) and with associated previous words (if a call). The station shall examine each successive redundant word phase ( $T_{rw}$ ) following the THIS IS (or THIS WAS) for the first (of up to four) nonreadable or nonvalid word(s). Failure to detect a proper word (or detection of an improper word) or detection of the last REPEAT, plus the last word wait delay time,  $T_{lww}$ , of  $T_{rw}$ , indicates the end of the received transmission. The only acceptable terminator sequence is THIS IS (or THIS WAS), DATA, REPEAT, DATA, REPEAT.

If all of the above sequential criteria are satisfied, and if B is not otherwise directed by the operator or controller, B shall immediately initiate an ALE response. All stations (such as B), even in single-channel mode, shall perform these analytical and timing discrimination functions. Therefore, in the single channel case, where no scan is available, the station shall reject the call if inappropriate, invalid, improper, or outside of the time limits.

After transmitting its individual scanning call to B, A shall pause (9) for B's reply (response) for a slightly extended wait time ( $T_{wrt}$ ), as B must be provided an additional period ( $T_t$ ) to tune (2) for an initial reply. However, called station B shall use the shorter single channel wait time ( $T_{wr}$ ) when waiting for A's reply (acknowledgement), because A has already tuned.

A shall wait and attempt to detect any ALE signals and read a reply (response) from B within the preset limited time,  $T_{wrt}$ . If A successfully reads an appropriate response ("TO A") starting within  $T_{wrt}$ , it shall plan to reply (acknowledge) and shall wait a preset limited time ( $T_{drrw}$ ) to read the next rotating redundant word, which in the protocol shown is the "THIS IS B" terminator. If A does not receive this appropriate response calling cycle ("TO A") starting within  $T_{wrt}$ , or if A does not later receive the appropriate terminator ("THIS IS B") starting within  $T_{lc}$  (plus  $T_m \text{ max}$ , if message included), A shall automatically terminate the protocol and resume scanning calling. If A receives the proper terminator word from B ("THIS IS B") starting within  $T_{lc}$  (plus  $T_m \text{ max}$ , if message included), A shall wait to reply (acknowledge), and shall expect the handshake to be successfully completed

## MIL-STD-188-141A

## APPENDIX A

within the time window  $T_{wr}$ . Meanwhile, A shall continue to read the incoming ALE signal and shall search for a new preset, limited "last word wait" time  $T_{lww} = T_{rw}$  for additional words (if any) and the end of the terminator signal (absence of detected word), which will trigger A's acknowledgement. If "THIS WAS B" is received, A's linking attempt is terminated. If an invalid sequence occurs, or the terminator end is not detected within  $T_{lww}$ , (plus the additional multiples of  $T_{rw}$  if an extended address), A shall terminate the protocol and resume scanning calling. If all the above sequential criteria are satisfied, if the terminator end is detected within  $T_{lww}$ , and if not otherwise directed by the operator or controller, A shall alert its operator that a correct response has been received, shall initiate the ALE acknowledgement (using "THIS IS A"), and shall unmute A's speaker. Both A and B shall continue to use the same methodology, criteria, and timing described above for the successful transfer of the acknowledgement, in which case, station B shall alert his operator that the correct acknowledgement has been received and shall unmute B's speaker. The bilateral link is now set up, confirmed, and available for the operator. If A is to terminate the handshake, it does not alert or unmute and uses "THIS WAS A" in the acknowledgement. This causes B to stay muted, not alert, and to resume scanning. If the entire set of scanned channels to be used for calling have been tried, and no successful handshake has been completed, the calling station (A) shall immediately resume receive scanning and shall alert the operator (or controller) of the failure.

NOTE: The total elapsed handshake time ( $T_{hs}$ ) in the example given on figure A-22 is about nine seconds on the channel.

70.4.4 Timing. The ALE system depends on a selection of timing functions for optimizing the efficiency and effectiveness of automatic link establishment. The primary timing functions and values are listed in table A-XIV. Annex A defines the timing symbols and annex B explains the timing analysis and computation.

TABLE A-XIV. Timing.

NOTE: Refer to annex A and annex B for details.

Basic system timing

- o Tone rate = 125 symbols per second (sps)
- o Tone period =  $T_{tone} = 8$  ms
- o On-air rate = 375 bps
- o On-air word:  $T_w = 130.66... ms$
- o On-air redundant word:  $T_{rw} = 3 T_w = 392$  ms

## MIL-STD-188-141A

## APPENDIX A

TABLE A-XIV. Timing -- Continued.

- o On-air leading redundant word:  $T_{lrw} = 2 T_{rw} = 784$  ms
- o On-air individual (net) address time:  $T_a = m \times T_{rw}$  for  $m = 1$  to 5 max words.  $T_a = 392$  ms to 1960 ms
- o Propagation:  $T_p = 0$  to 70 ms

System timing limits

- o Address size limit 5 word:  $T_a \text{ max} = 1960$  ms
- o Address first word limit:  $T_{a1} = 392$  ms
- o Call time limit 12 words:  $T_c \text{ max} = 4704$  ms
- o Group addresses first word limit:  $T_{c1} = 1960$  ms
- o Maximum scan period:  $T_s \text{ max} = 50$  s
- o Message section time limit, AMD (90 characters) and DTM (84 characters) (unless modified by COMMAND):  $T_m \text{ max AMD} = 11.76$  s
- o Message section time limit, DTM (1053 characters):  $T_m \text{ max DTM} = 2.29$  min (entire data block)
- o Message section time limit, DBM, (37545 characters):  $T_m \text{ max DBM} = 23.36$  min (entire deeply interleaved block with COMMAND)
- o Termination time limit:  $T_x \text{ max} = 1960$  ms

Individual calling

- o Minimum dwell time:  $T_d(5) \text{ min} = 200$  ms, basic receive scanning (5 channels per second)
- o Minimum dwell time:  $T_d(2) \text{ min} = 500$  ms, minimum receive scanning (2 characters per second (chps))
- o Probable maximum dwell per channel, for  $T_s$  computations, let  $T_d = T_{drw} = 784$  ms
- o Number of channels:  $C$
- o Scan period:  $T_s = C \times T_d$
- o Call time:  $T_c = T_a$  (or more whole addresses as required,  $\Sigma T_a$ ) in  $T_{lc}$

## MIL-STD-188-141A

## APPENDIX A

TABLE A-XIV. Timing -- Continued.

- o Call time:  $T_{c1} = T_{a1}$  (or more different first words,  $\Sigma T_{a1}$ ) in  $T_{sc}$
- o Leading call time:  $T_{lc} = 2T_c$
- o Redundant call time:  $T_{rc} = T_{lc} + T_x$
- o Scanning call time:  $T_{sc} = n \times T_{c1} \geq T_s$
- o Calling cycle time:  $T_{cc} = T_{sc} + T_{lc} \geq T_s + T_{lc}$
- o Scanning redundant call time:  $T_{src} = T_{sc} + T_{rc}$
- o Last word wait delay:  $T_{lww} = T_{rw} = 392 \text{ ms}$
- o Wait for response time delay:  $T_{wr} = T_{td} + T_p + T_{lww} + T_{ta} + T_{rwp}$   
(if not first transmission...) +  $T_{ld} + T_p + T_{rd}$
- o Late detect delay:  $T_{ld} = T_w = 130.66... \text{ ms}$
- o Redundant word phase delay:  $T_{rwp} = 0 \text{ to } T_{rw}$  (0 to 392 ms)
- o Turnaround time:  $T_{ta} = T_{rd} + T_{dek} + T_{enk} + T_{tc} + T_{tk} + T_{td}$
- o Wait for calling cycle end time:  $T_{wce} = 2 \times \text{own } T_s$  (default)
- o Tune time:  $T_t$  (as required by slowest tuner)
- o Wait for reply and tune time:  $T_{wrt} = T_{wr} + T_t$
- o Detect signaling period:  $T_{ds} \leq (T_d(5) = 200 \text{ ms})$
- o Detect redundant word period:  
 $T_{drw} = T_{rw} + \text{spare } T_{rw} = 784... \text{ ms}$
- o Detect rotating redundant word period:  
 $T_{drrw} = 2 T_{rw} + \text{spare } T_{rw} = 1176 \text{ ms}$

Sounding

- o Redundant sound time (similar to  $T_{lc}$ ):  $T_{rs} = 2 T_a$  (caller)
- o Scanning sound time (similar to  $T_{sc}$ ):  $T_{ss} = n \times T_a$  (caller)  $\geq T_s$
- o Scanning redundant sound time (similar to  $T_{cc}$ ):  
 $T_{srs} = T_{ss} + T_{rs} \geq T_s + T_{rs}$

## MIL-STD-188-141A

## APPENDIX A

TABLE A-XIV. Timing -- Continued.Star calling

- o Minimum standard slot widths:  $T_{sw} \text{ min} = 14, 17 T_w$  for 1st handshake slots, or 17, 20 for subsequent handshake slots, or other  $T_w$  as set by COMMAND.
- o Slot widths:  $T_{sw} = 14, 17, 10, \text{ or other } T_w$
- o Slot number: SN
- o Slot wait time:  $T_{swt} = T_{sw} \times SN$  (uniform case)
- o Slot wait time (delay to start reply):  $T_{swt}$  for each slot is the sum of all the previous slot times and so must be different for each slot and is cumulative.  $T_{swt}(SN) = T_{sw} \times SN$  for uniform slots or generally  $T_{swt}(SN) = SN \times [5 T_w + 2 T_a \text{ (caller)} + \text{(optional LQA)} T_{rw} + \text{(optional message)} T_m] + T_a \text{ (caller)} + \{(\text{sum of all previous called addresses}) \sum_{m=1}^{SN-1} T_a(m) \text{ (called)}\}$
- o Number of slots: NS
- o Wait for net reply (at calling station):  $T_{wrn} = (T_{sw} \times NS)$  for uniform slots, or generally  $T_{wrn} = T_{swt}(NS)$
- o Wait for net acknowledgement (at called stations):  $T_{wan} = T_{wrn} + T_{drw}$
- o Turnaround and tune limits:  $T_{ta} + T_t \leq 360, 2100, \text{ or } 1500 \text{ ms}$ , depending on whether slot 0, 1, or others
- o Maximum star group wait for acknowledgement:  $T_{wan} \text{ max} = 107 T_w + 27 T_a \text{ (caller)} + 13 T_{rw} \text{ (optional LQA)} + 13 T_m \text{ (optional message)}$
- o For late arrival stations, if caller uses one word addresses and no message calling:  $T_{wan} \text{ max} = 188 T_w, \text{ or } 277 T_w \text{ if LQA}$

Programmable timing parameters: typical values

- o Wait (listen first):  $T_{wt} = 2 \text{ seconds}$ , general uses; = 784 ms, ALE/data only channels
- o Tune time:  $T_t = 8 T_w = 1045.33... \text{ ms}$  (default), "blind" first call; = 20 seconds, next try
- o Automatic sounding:  $T_{ps} = 30 \text{ minutes}$
- o Wait for activity:  $T_{wa} = 30 \text{ seconds}$



## MIL-STD-188-141A

## APPENDIX A

70.5 Sounding.

70.5.1 Introduction. Sounding is the ability to empirically test selected channels (and propagation paths) by providing a very brief, beacon-like, identifying broadcast which may be utilized by other stations to evaluate connectivity, propagation, and availability, and to select known working channels for possible later use for communications or calling. The sounding signal is a unilateral, one-way transmission which is performed at periodic intervals on unoccupied channels. The implementation is simple: a timer is added to the controller to periodically initiate sounding signals (if the channel is clear). Sounding is not an interactive, bilateral technique, such as polling. However, the identification of connectivity from a station, by hearing its sounding signal, does indicate a high probability (but not guarantee) of bilateral connectivity and it may be done entirely passively at the receiver. If propagation changes slowly, a long interval between soundings of perhaps one or two hours may be sufficient. However, if propagation is erratic and rapidly changing and the connectivity information is critical, sounding may be conducted several times within each hour.

As sounding uses the standard ALE signaling, any station can receive sounding signals. As a minimum, the signal (address) information shall be displayed to the operator and, for stations equipped with connectivity and LQA memories, the information shall be stored and used later for linking. If a station has had recent transmissions on any channels which are to be sounded on, it may not be necessary to sound on those channels again until the sounding interval, as restarted from those last transmissions, has elapsed. In addition, if a net (or group) of stations is polled, their responses shall serve as sounding signals for the other net (or group) receiving stations and also should reset the sounding interval timer to a fresh start while compactly concentrating the sounding equivalents in a small amount of channel time. Specifically, in the single channel case, any identifiable transmission (THIS IS, THIS WAS) shall reset the sounding timer. In the multichannel case, the longer scanning sounds shall reset the sounding timer, as well as a net (or group) protocol which contains all desired receiving stations.

All stations shall be capable of performing periodic sounding on clear prearranged channels. The sounding capability may be selectively activated by, and the period between sounds shall be adjustable by the operator or controller, according to system requirements. When available, and not otherwise committed or directed by the operator or controller, all ALE stations shall automatically and temporarily display the addresses of all stations heard, with an operator selectable alert. The address information shall be derived from sounding or the conclusion section of other ALE transmissions. The display shall have the capability to show and temporarily retain the address of the last station heard. If the operator or controller initiates the call function, an ALE call to that address shall automatically be sent on that channel.



## MIL-STD-188-141A

## APPENDIX A

The structure of the sound is virtually identical to that of the basic call which was described earlier. However, the calling cycle is not needed and there is no message section. It is only necessary to send the conclusion (terminator) which identifies the transmitting station. See figure A-23. The type of word, either THIS IS or THIS WAS (but never both), indicates whether potential callers are encouraged or ignored, respectively. The minimum redundant sound time ( $T_{rs}$ ) is equal to the standard one-word address leading call time ( $T_{lc}$ ); that is,  $T_{rs} = T_{lc} \text{ min} = 2 T_a \text{ min} = 2 T_{rw} = 784 \text{ ms}$ . Described below are both single-channel and multiple-channel protocols, plus detailed timing and control information, for designing stations.

**70.5.2 Single channel.** The fundamental capability to automatically sound on a channel is provided by the sounding protocol as shown on figure A-23. Stations shall employ this protocol for single-channel sounding, connectivity tracking, and the broadcast of their availability for calls and traffic. The basic protocol consists of only one part: the sound. In this one-channel example, the sounding station A initially performs the identical steps which are followed in the individual calling protocol presented in 70.4.3. If multichannel stations are to be sounded to, A should use the totally compatible scanning sounding protocol, presented in 70.5.3. Normally, both A and all other stations, such as B, are on channel and available; that is, they are "always listening" and they "always track connectivities with other stations," if they have a connectivity matrix. Starting with the sound, station A shall broadcast to station B and all other stations by transmitting the sound containing his own address ("THIS IS A"). If A is encouraging calls and receives one, A shall follow the sound with the optional handshake protocol described in 70.5.4. If A plans to ignore calls, he shall use the THIS WAS, which advises B and the others not to attempt calls, and then A shall immediately return to normal "available." As this is a single-channel example, with nowhere for A to go, A actually would still be contactable, unless otherwise directed by the operator or controller. However, in some systems it is necessary for a multichannel station A to periodically sound to a single-channel network, usually to inform them that he is active and available on that channel, although scanning. Therefore, if B, a single-channel station, needs to contact A at that time, the optional handshake may be used after the THIS IS sound. If contact is required later, the standard individual scanning calling protocol would be used even though on a single channel. Upon receipt of A's sound, B and the other stations shall display A's address as a received sound and, if they have an LQA and connectivity memory, they shall appropriately store the connectivity information. In the single-channel case, and if B or one of the other stations requires contact with A, they may attempt to link by initiating a standard individual call, by specific operator or controller direction as part of the optional handshake, despite the THIS WAS advisory.

**70.5.3 Multiple channels.** Sounding must be compatible with the scanning timing. All stations shall be capable of performing the scanning sounding protocols described herein, even if on a fixed frequency. See figures A-23, A-24, and A-25. These protocols establish and positively confirm unilateral connectivity between stations on any available mutually scanned channel, and they assist in establishment of links between stations which are waiting for contact. Stations shall employ these protocols for multichannel sounding, connectivity tracking, and the broadcast of their availability for calls and traffic.

MIL-STD-188-141A

APPENDIX A

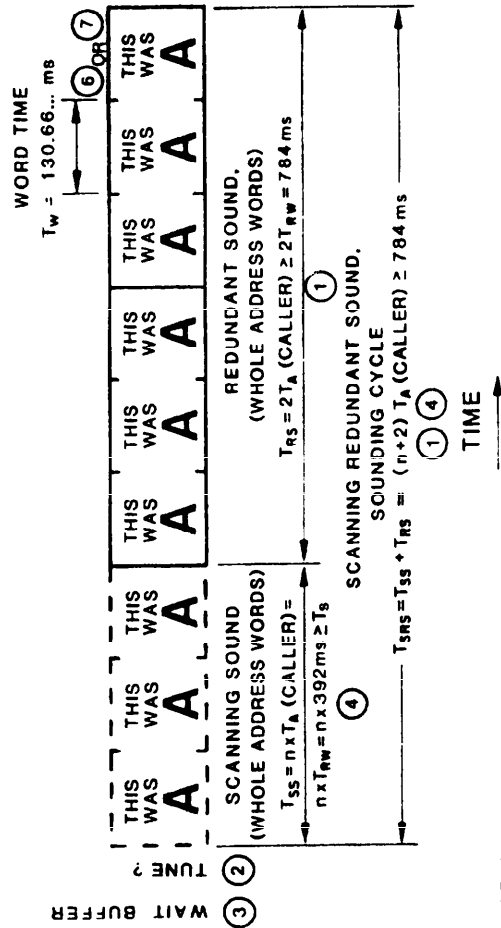

NOTES:

- ① SINGLE-CHANNEL (AND MULTIPLE-CHANNEL) EXAMPLES SHOWN WITH ONE-WORD ADDRESSES.
- ② TUNING REQUIRED INITIALLY ( $T_T$ ).
- ③ WAIT (LISTEN) TIME ( $T_{WT}$ ).
- ④ SOUNDING CYCLE ( $T_{SRS}$ ) DEPENDS ON SCAN PERIOD ( $T_S$ ).
  - ⊕  $T_{SRS}$  - USE WHOLE ADDRESS ONLY.
  - ⊕  $T_{SS}$  (OPTIONAL IF NONSCAN).
- ⑥ THIS WAS INDICATES CALL REJECTION.
- ⑦ THIS IS INDICATES CALL ACCEPTANCE (A WILL PAUSE AFTERWARDS).

FIGURE A-23. Basic sounding structure.

MIL-STD-188-141A

APPENDIX A

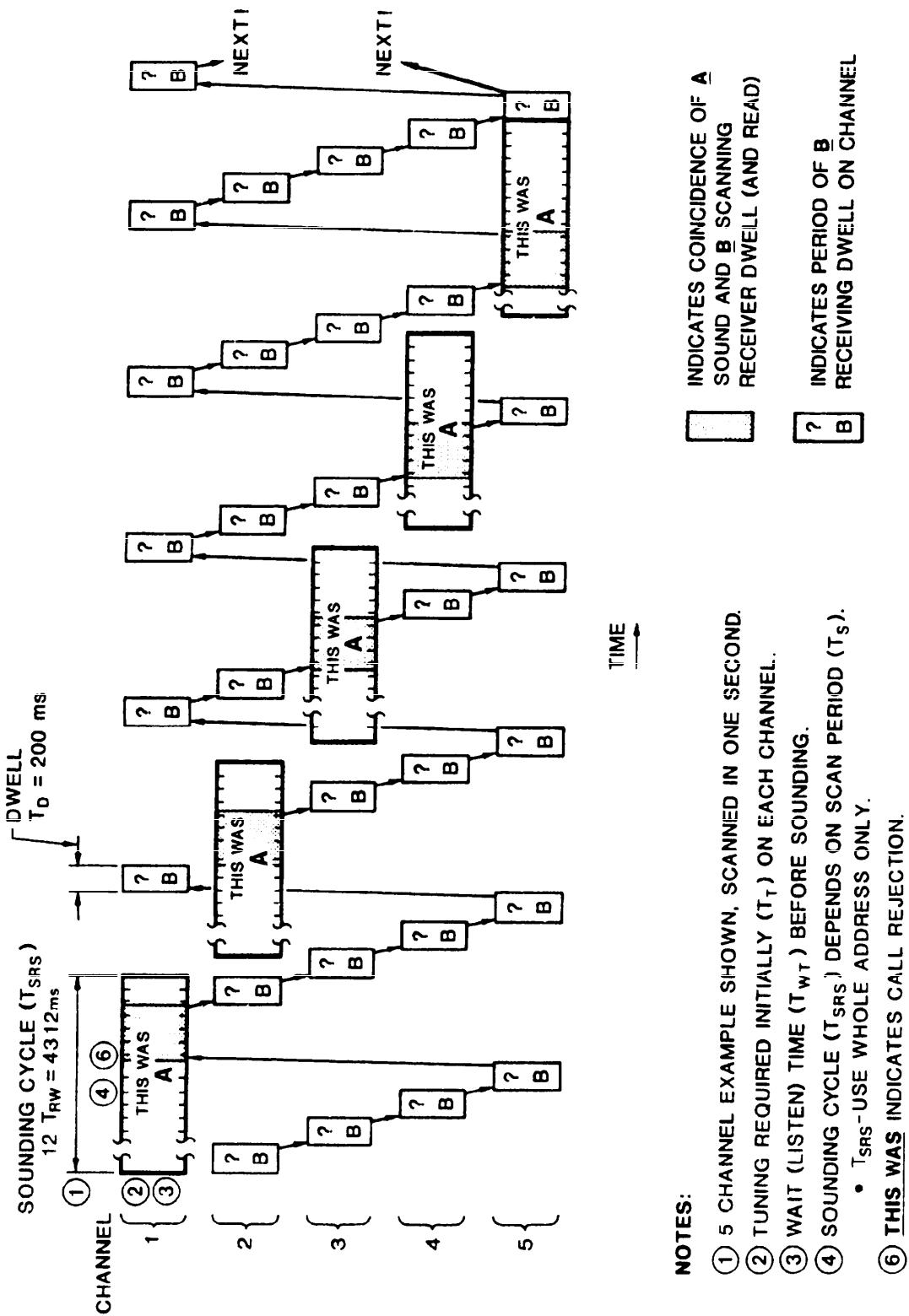

NOTES:

- ① 5 CHANNEL EXAMPLE SHOWN, SCANNED IN ONE SECOND.
- ② TUNING REQUIRED INITIALLY (T<sub>T</sub>) ON EACH CHANNEL.
- ③ WAIT (LISTEN) TIME (T<sub>WT</sub>) BEFORE SOUNDING.
- ④ SOUNDING CYCLE (T<sub>SRS</sub>) DEPENDS ON SCAN PERIOD (T<sub>S</sub>).
  - T<sub>SRS</sub>-USE WHOLE ADDRESS ONLY.
- ⑥ THIS WAS INDICATES CALL REJECTION.

FIGURE A-24. Call rejection scanning sounding protocol.

APPENDIX A

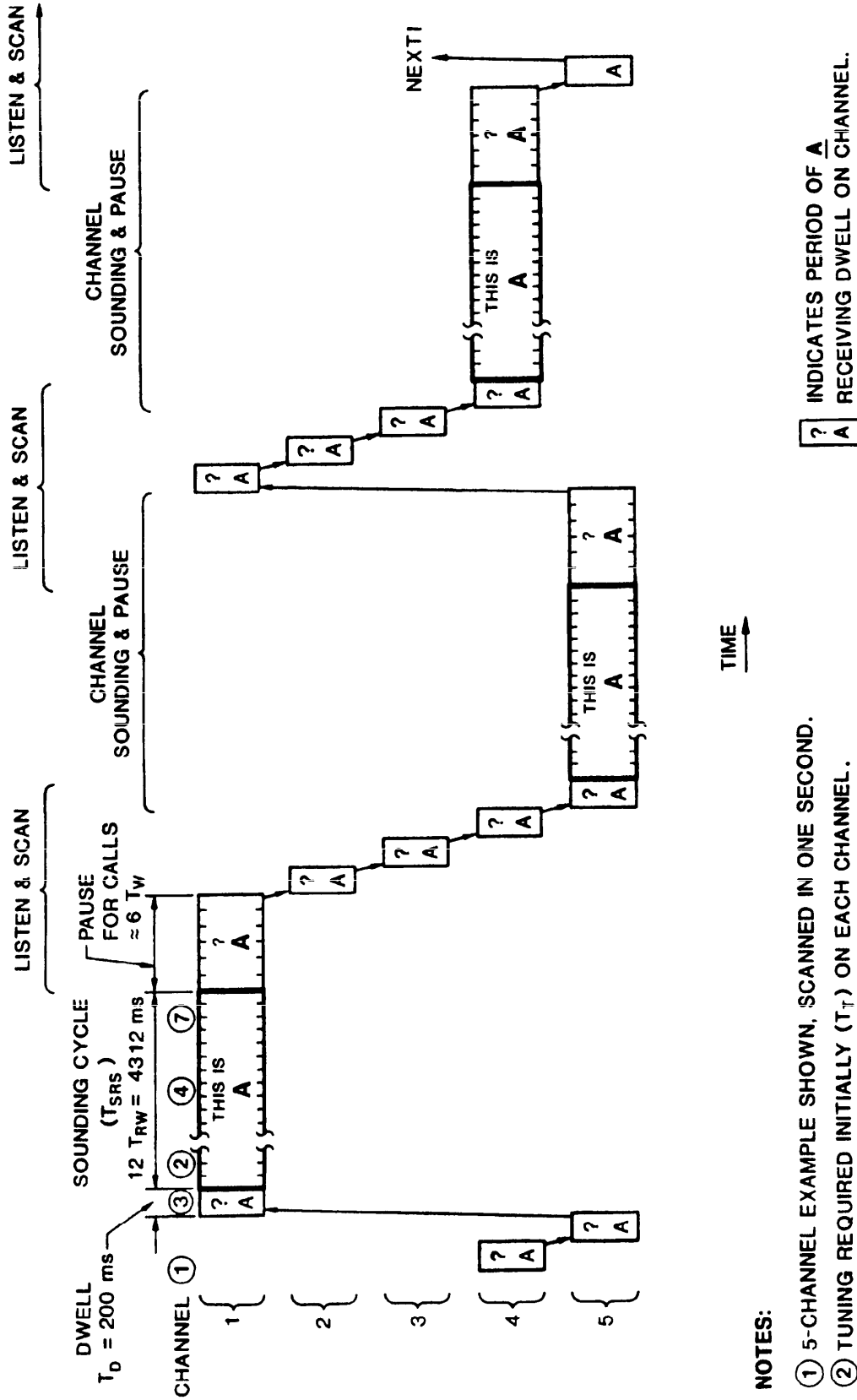

NOTES:

- ① 5-CHANNEL EXAMPLE SHOWN, SCANNED IN ONE SECOND.
  - ② TUNING REQUIRED INITIALLY (T<sub>T</sub>) ON EACH CHANNEL.
  - ③ WAIT (LISTEN) TIME (T<sub>WT</sub>) USES DWELL T<sub>D</sub>.
  - ④ SOUNDING CYCLE (T<sub>SRS</sub>) DEPENDS ON SCAN PERIOD (T<sub>S</sub>).
    - T<sub>SRS</sub> - USE WHOLE ADDRESS ONLY.
  - ⑦ THIS IS INDICATES CALL ACCEPTANCE (A WILL PAUSE AFTERWARDS).
- ? INDICATES PERIOD OF A  
A RECEIVING DWELL ON CHANNEL.

FIGURE A-25. Call acceptance sounding protocol.

## MIL-STD-188-141A

## APPENDIX A

The basic protocol consists of only one part, the scanning sound. See figure A-23. All timing considerations and computations for individual scanning calling shall apply to scanning sounding, including sounding cycle times and (optional) handshakes times.

NOTE: The scanning sound is identical to the single-channel sound except for the extension of the redundant sound time ( $T_{rs}$ ) by adding words to the scan sounding time ( $T_{ss}$ ) to form a scanning redundant sound time ( $T_{srs}$ ); that is,  $T_{srs} = T_{ss} + T_{rs}$ . The scan sounding time ( $T_{ss}$ ) is identical in purpose to the scan calling time ( $T_{sc}$ ) for an equivalent scanning situation, but it only uses the whole address of the transmitter.

The channel-scanning sequences and selection criteria for individual scanning calling shall also apply to scanning sounding. The channels to be sounded are termed a "sound set," and usually are identical to the "scan set" used for scanning. See figure A-24. In this illustration, station A is sounding and station B is scanning normally. If a station (A) plans to ignore calls (from B) which may follow A's sound, the following call rejection scanning sounding protocol shall be used. In a manner identical to the previously described individual scanning call, A lands on the first channel in the scan set (1), waits ( $T_{wt}$ ) to see if the channel is clear (3), tunes ( $T_t$ ) its coupler, comes to full power, and initiates the frame of the scanning redundant sound time ( $T_{srs}$ ). This scanning sound is computed to exceed B's (and any others) scan period ( $T_s$ ) by at least a redundant sound time ( $T_{rs}$ ), which will ensure an available detection period exceeding  $T_{drw} = 784$  ms. In this five-channel example, with B scanning at 5 chps, A sounds for at least 12  $T_{rw}$  (4312 ms). A also uses "THIS WAS A", redundantly, to indicate that calls are not invited. Upon completion of the scanning sounding frame transmission, A immediately leaves the channel and goes to the next in the sound set. This procedure repeats until all channels have been sounded, or skipped if occupied. When the calling ALE station has exhausted all the prearranged sound set channels, it shall automatically return to the normal "available" receive scan mode. As shown in the illustration, the timing of both A and B have been prearranged to ensure that B has at least one opportunity, on each channel, to arrive and "capture" A's sound. Specifically, B arrives, detects sounds, waits for good words, reads at least three (redundant) "THIS WAS A" (in 3 to 4  $T_w$ ), stores the connectivity information (if capable), and departs immediately to resume scan.

There are several specific protocol differences when station A plans to welcome calls after the sound. See figure A-25. In this illustration, A is sounding and B is scanning normally. If a station (A) plans to welcome calls (from B) which may follow his sound, the following call acceptance scanning sounding protocol shall be used. In this protocol, A sounds for the same time period as before. However, since A is receptive to calls, he shall use his normal scanning dwell time ( $T_d$ ) or his preset wait before transmit time ( $T_{wt}$ ), whichever is longer, to listen for both channel activity and calls before sounding. If the channel is clear, A shall initiate the scanning sound identically to before, but with "THIS IS A". At the end of the sounding frame, A shall wait for calls identically to the wait for reply and

## MIL-STD-188-141A

## APPENDIX A

tune time ( $T_{wrt}$ ) in the individual scanning calling protocol, in this case shown to be  $6 T_w$  (for fast-tuning stations). During this wait, A shall (as always) be listening for calls which may coincidentally arrive even though unassociated with A's sound, plus any other sound heard, which A shall store as connectivity information if polling-capable. If no calls are received, A shall leave the channel.

70.5.4 Optional handshake. In the previous descriptions, one alternative action is the implementation of an optional handshake with a station immediately after its sound. This protocol is identical in all regards to the single channel individual call protocol, except that it is manually or (DO) automatically (operator or controller) triggered by acquisition of connectivity from the station which is to be called. See figure A-26. In this illustration, A is scanning sounding and is receptive to calls, and B is receive scanning (or waiting in ambush on a channel) and requires contact with A if heard. A uses the standard call acceptance scanning sound, including the "THIS IS A" and the pause for calls. In this case, B calls A. When ALE stations are scanning sounding and receptive to calls, or require contact with such a station, the optional handshake protocol should be used. The calling station should immediately initiate the call upon the determination that the station to be called has terminated its transmission. A wait time before transmit time is not required. Therefore, if B hears A's sound and is seeking A, B calls immediately using the simple single-channel call. Also, if B's operator or controller identifies A's address it can attempt the optional handshake.

70.6 Multiple stations operations.

70.6.1 General. A critical requirement for MF/HF systems is the capability to rapidly initiate links with, and interoperate with, multiple stations. Linking among multiple stations is significantly more difficult than linking between two individual stations because the quantity of required MF/HF links can increase exponentially as stations are added, and all the links still retain their individual challenges of propagation and interference. In many cases, total interconnectivity cannot be achieved on any single frequency because, regardless of power or effort, propagation will not support communications between several stations. This section describes these multiple-station operations.

There are three fundamental network configurations from which any network may be constructed, and each requires significantly different quantities of links ( $L$ ), depending on the numbers of stations ( $N$ ) which are included:

- o Link  $L = 1$
- o Star  $L = (N-1)$
- o Multipoint  $L = (N^2-N)/2$

MIL-STD-188-141A

APPENDIX A

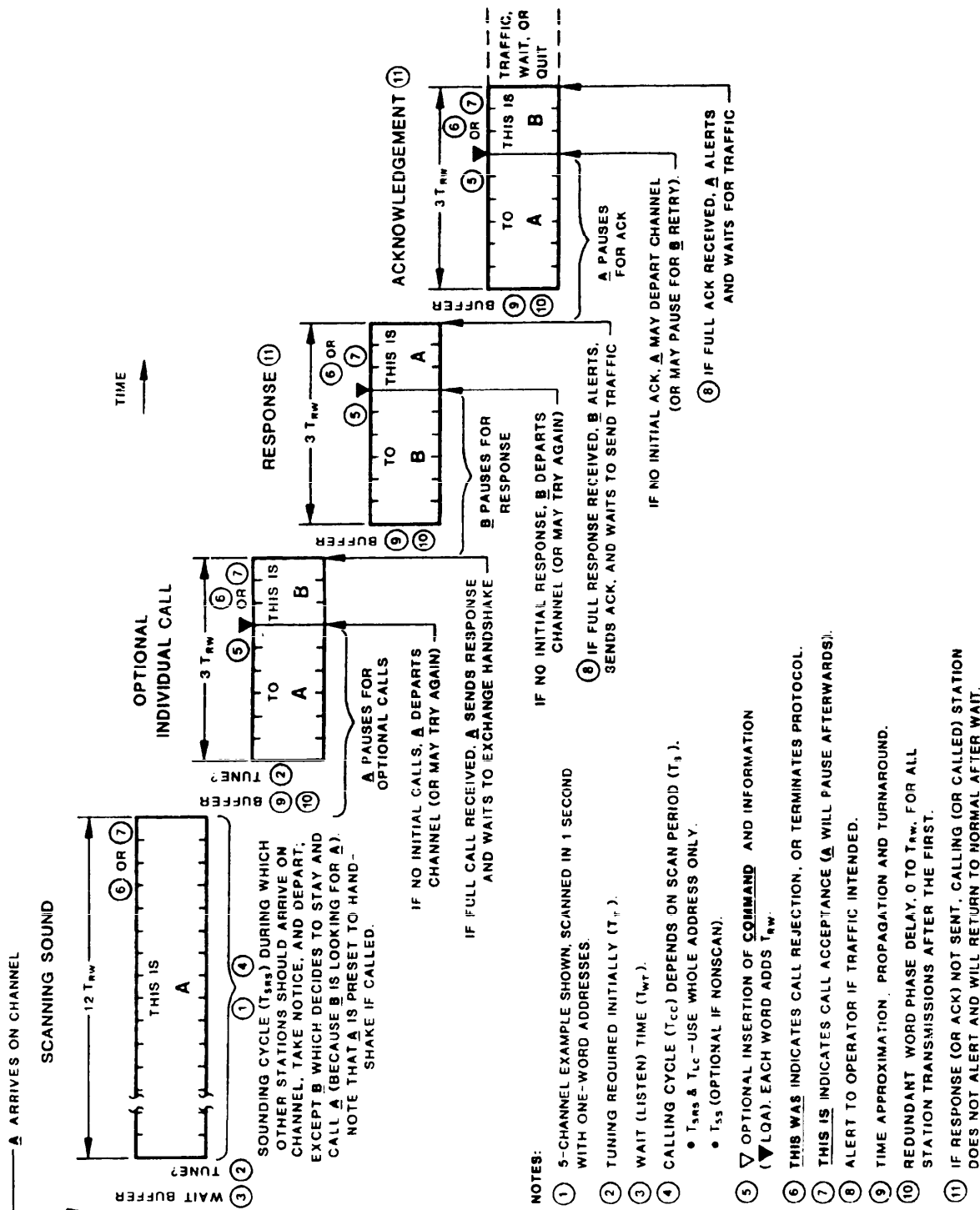

FIGURE A-26. Scanning sounding with optional handshake protocol.



## MIL-STD-188-141A

## APPENDIX A

A link involves only two stations and requires only a single point-to-point path. A star involves several stations in a "one-to-many" configuration and requires one less link than the number of stations. A multipoint involves several stations in a "many-to-many" configuration and requires an exponential quantity of links. In this section, two fundamental types of multiple-station operations are described:

- o Star net
- o Star group

70.6.2 Star net. A star net is a prearranged collection of stations which is to link and interoperate primarily with a single hub station which, in most cases, has the separate function of net control station (NCS). A star net is usually organized and managed with significant prior knowledge of the member stations, including their quantity, identities, capabilities, requirements, and in most cases, their locations and necessary connectivities. The purpose of a star net call, like any net call, is to rapidly and efficiently establish contact with multiple prearranged (net) stations, simultaneously (or nearly simultaneously), by the use of a single net address. This address is common to all net members. See section 60.5. In association with the net address, each station must also store information regarding its proper response(s) and timing(s), as described below and as described in 40.4 and 40.5. A net manager may select minimum, uniform, or variable slot widths as required and as described herein.

When a star net calling type function is required, stations shall use the star net (scanning) calling protocols described herein for all single-channel (and multichannel) calling, polling, and interoperations. See figure A-27. As shown, station A is calling NET, which consists of three stations, B, C, and D. The initial net scanning call shall be identical to the individual scanning call except that the net address shall be substituted for the individual address. At the end of the net call, the net stations shall not respond immediately as in the individual call case. Instead, they shall respond in prearranged time slots to avoid mutual interference and to greatly speed the response process. If the caller is a member of the called net, his assigned slot should remain empty.

In the example illustrated, there are four time slots, designated slot 0 through slot 3, and one-word addresses are used. In this case, they have been preset (by net management) at the standard system uniform minimum slot width of  $14 T_w$  (1829.66... ms). Station B is assigned to slot 1, C to slot 2, and D to slot 3. At the end of A's call to NET, the net members B, C, and D (if they heard the net call), prepare to respond within their preset slots, as follows. When the end of A's terminator (THIS IS A) is detected, the net stations immediately start an internal "slot wait timer" (SWT), preset to identify their slot time ( $T_{swt}$ ), start their normal tuneup and prepare to go to full power and start the frames of their responses. Slot 0 is reserved primarily for these purposes. However, after each station is ready to respond, it ceases all emissions, returns to receive, and waits for the SWT to timeout ( $T_{swt} = 0$ ). Each station's SWT is set to a time value ( $T_{swt}$ ) which, in this uniform and minimum case, equals the product of his assigned slot number (SN) times the standard (or prearranged) slot width ( $T_w$ ).



## MIL-STD-188-141A

## APPENDIX A

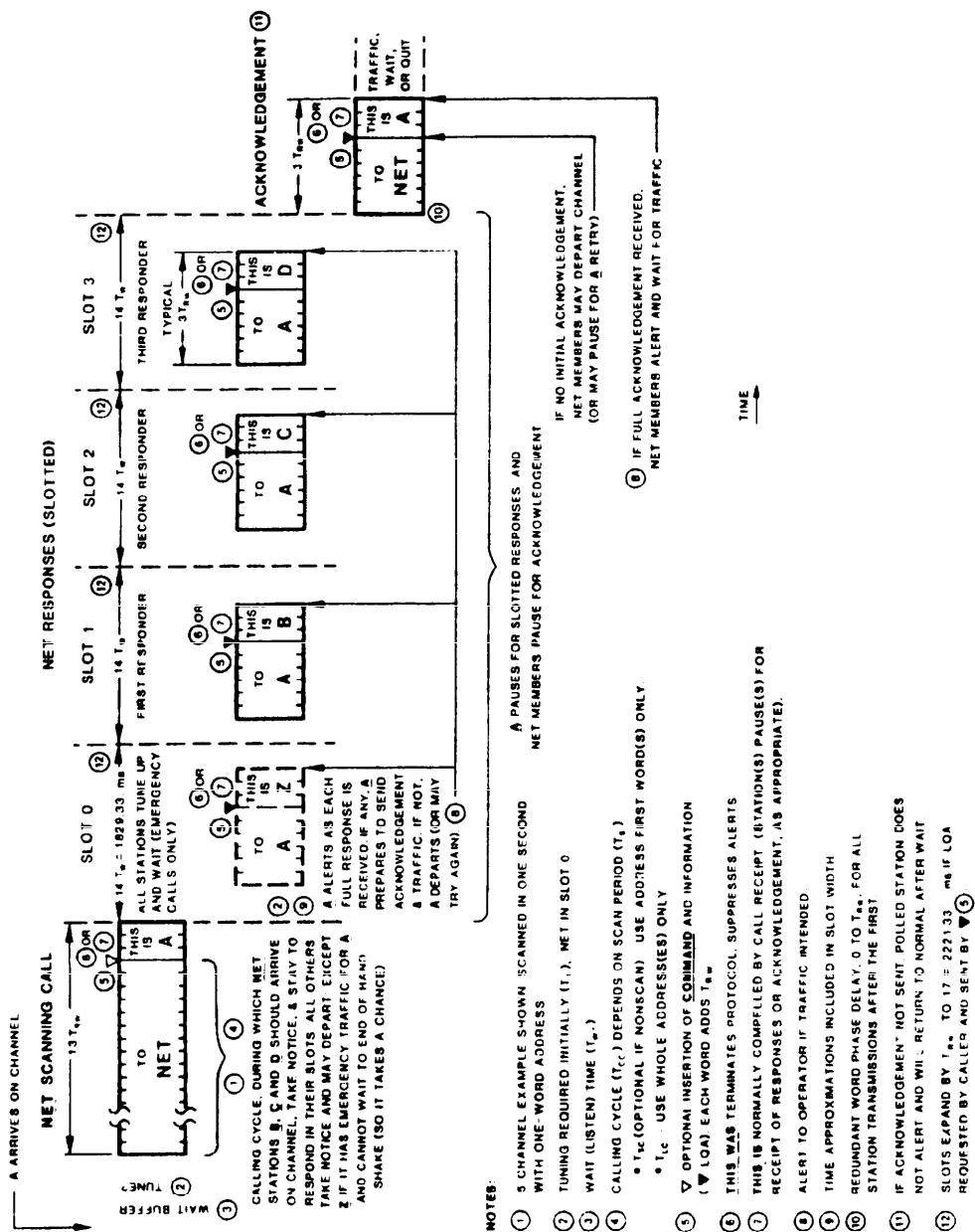

FIGURE A-27. Star net scanning calling protocol.

## MIL-STD-188-141A

## APPENDIX A

That is,  $T_{swt} = T_{sw} \times SN$ . However, as a system standard default,  $T_{sw}$  is usually the minimum  $14 T_w = 1829.33... \text{ ms}$ , but in any case shall always be an integral multiple of the word time ( $T_w$ ); that is,  $T_{sw} = n \times T_w$ , therefore  $T_{swt} = n \times T_w \times SN$ . For a net call, each net station's  $T_{swt}$  associated with that net is preprogrammed along with the net address (NET). After all net stations have tuned and are ready to respond, they shall wait for their SWT to timeout and trigger their responses, and (as always) continue to monitor the channel for any other ALE signals, including those from the other net members. If capable, they shall store this unilateral connectivity information in memory.

Once the star net protocol has been initiated, the stations shall be locked into the protocol timing and shall not be deferred or delayed even by extraneous or legitimate calls (unless emergency or priority override). Valid calls shall be read (if possible) and should be stored for recall as soon as the net protocol is ended.

Meanwhile, A has automatically set its "wait for response and tune timer" (WRTT) to a preset "wait reply net" call value ( $T_{wrn}$ ) equal to the product of the total number of slots (NS) and the slot width ( $T_{sw}$ ); that is, in this uniform case,  $T_{wrn} = (NS \times T_{sw})$ . A shall start its WRTT at the moment that its net call terminator (THIS IS A) ends and its transmission ceases. Unless otherwise directed by the operator or controller, A shall remain on channel throughout all slot times (entire  $T_{wrn}$ ), regardless of which responses are received, if any. As each slotted response arrives, A shall alert the operator and display the responding station's address. In addition, if A is also capable, A shall store the bilateral connectivity information in memory. At the end of the slots ( $Swt = 0$ ), A shall immediately send an acknowledgement to the net (unless inhibited).

As each net member's SWT triggers its slotted response, it shall immediately key its (already tuned) transmitter, wait until up to at least 90 percent of full power, release its response frame, and return to receiving on the channel. The responses shall be identical to those in the individual call, but in the slots. If capable, the station continues to acquire and store connectivity information. Each net member station shall have its own "wait for response and tune timer" (WRTT) for use in determining the calling station's (A) expected acknowledgement. Upon receipt of the net call, the called net member station's WRTT timers are automatically preset to the value ( $T_{wan}$ ) equal (in this uniform case) to the product of the total number of slots (NS) and the slot width ( $T_{sw}$ ) plus a minimum leading call ( $T_{lc \text{ min}} = 2 T_{rw}$ ). That is,  $T_{wan} = (NS \times T_{sw}) + T_{lc \text{ min}} = T_{wrn} + 2 T_{rw}$ . The net members stations start their WRTT at the detected end of A's net call (not at the end of their own response, as in the individual call protocol) and wait for the acknowledgement from A before their WRTT times out. Note that the value for their WRTT ( $T_{wan}$ ) is the same as that for the caller's (A's) WRTT, except that it shall add a margin ( $T_{lc \text{ min}}$ ) to detect the acknowledgement (TO NET).

## MIL-STD-188-141A

## APPENDIX A

At the end of the slot times, net calling station A should have acquired all successful responses from the net stations B, C, and D, its WRTT (starting at Trn) should time out to 0, and A shall automatically send its acknowledgement, unless no responses have arrived or A is otherwise directed by the operator, controller, or protocol. A's acknowledgement shall be identical to the individual call protocol acknowledgement, except that the net address NET shall be substituted for the individual address as in the initiating call. Just as in the individual call protocol, if A sends "THIS WAS A", the net members B, C, and D shall immediately return to normal scanning. If A sends "THIS IS A", they shall stay, for a preset, limited time, to handle traffic.

As a variation to the net acknowledgement, A may select one or any combination of responding stations and substitute an individual (or group) call acknowledgement to any selected station(s) to retain them. If the calling station sends an acknowledgement in individual or group call format (and uses THIS IS), following a net call, the specified stations shall remain and be linked. The nonspecified responders shall depart and resume scanning. The caller shall not use THIS WAS in this variation. If rejection of selected stations is required, the caller shall use the standard net acknowledgement. The caller should follow the acknowledgement with a standard link termination call (THIS WAS) addressed to the specific rejected stations.

NOTE: In the five-channel net call example shown on figure A-27, the total elapsed handshake time (Ths) is less than 14 seconds on the channel without tuning. Since a net call is prearranged, the number of slots and their sizes may be tailored to fit the net, including speed of tuning and turnaround, propagation times, address sizes, inclusions of LQA and messages, and any other relevant factors. Slot width (Tws) is affected by many factors including maximum propagation times each way, signal detection delays, station turnaround and tuning times. The 14-Tw standard minimum slot size has been designed to enable full responses (TO and THIS IS) with single-word addresses to propagate to and from the other side of the globe and use commonly available HF transceivers and tuners.

If LQA is required, the slots and responses shall require an additional  $Trw = 3 Tw$  for the data. The standard slot shall be  $Tsw = 14 Tw$  (1829.33... ms), shall contain a standard basic response word of  $9 Tw$  (1176 ms), and shall employ single-word (no more than three characters) addressing. If the net calling station requests LQA, all slots and responses shall automatically expand by  $Trw$  (392 ms), regardless of the preset referenced slots, unless otherwise directed by the specific prearrangements when the net was set up. When prearranging the specific slots and sizes for a specialized network, and if the net requires more than one-word addressing for any net member address, or the inclusion of any other prearranged message(s), that specific response and slot shall be expanded by  $Trw$  (392 ms) per additional word required. All following slots shall be shifted over (delayed) by  $Trw$  per word also.

## MIL-STD-188-141A

## APPENDIX A

The slotted general formula for determining the correct timing for tailored net responses in nonminimum or nonuniform cases shall be as follows:

The slot wait timer time (Tswt) for a selected slot number (SN) is

$$T_{swt}(SN) = SN \times [5 T_w + 2 T_a (\text{caller}) + (\text{optional LQA}) T_{rw} (\text{optional message}) T_m] + T_a (\text{caller}) + \left[ \sum_{m=SN-1}^{m=1} T_a(m) (\text{called}) \right]$$

$T_a$  (caller) is the address length (in  $T_{rw}$ ) of the calling station;  $T_a(m)$  (called) is the address length of a preceding called station (in slot  $m$ ). (Optional LQA) $T_{rw}$  is an optional LQA if requested by COMMAND LQA, and (optional message) $T_m$  is an optional message section (same size for all) if requested by COMMAND. The slotted general formula for the calling station wait for net reply timer shall be  $T_{wrn} (\text{calling}) = T_{swt} (NS)$  where  $T_{swt} (NS)$  is  $T_{swt} (SN)$  computed for maximum  $NS$  used. The slotted general formula for the called station acknowledgement timer shall be  $T_{wan} (\text{called}) = T_{wrn} (\text{calling}) + 2 T_{rw}$ .

Slot 0 shall normally be used at the net tuneup period. This enables commonly available MF/HF equipment to participate in fast-slotted response operations despite relatively slow tuner and turnaround times. When used in multiple-station slotted operations (net or group calls) and when initiating normal responses, stations shall be capable of performing a complete turnaround including tuning (but not  $T_{lww}$ ) in no more than 1500 ms ( $T_{ta} + T_t$ ), from the arrival of the end of the call terminator to the start of the proper response frame calling cycle, as measured at the antenna input/output connection.  $T_{ta}$ , the turnaround time, shall include decoding, encoding, transmit/receive switching, control handshaking, propagation within the transmitter and receiver, and all other delays internal to the station.  $T_t$  is the tune time. The sole exception is a station assigned to slot 1, which must turn around and tune in not more than 2100 ms ( $T_{ta} + T_t$ ).

An additional function for slot 0 is to provide a method for emergency "interrupt" calling by other stations not in the net, or net stations with critical needs. See figure A-27. Upon receipt of the net call from A, the unassociated station Z decides that an emergency call is required, and it initiates the optional handshake protocol described previously. Station Z must be a fast turnaround station, to avoid colliding with proper net stations' responses. When used in a multiple station slotted operations (net or group calls), and initiating an emergency call into slot 0, stations shall be capable of performing a complete turnaround and tune in no more than 360 ms ( $T_{ta} + T_t$ ), as defined previously for normal responses.

A second mode which is necessary for nets with very slow tuners (over one second) or which require operator manual interaction, is the "net tune and standby." In this case, all net stations tune up in slot 0 (and more time if necessary) and stand by for a preset, limited time. This limited time is typically implemented through the standard WRTT, being preset to a selected

## MIL-STD-188-141A

## APPENDIX A

"net wait response time" ( $T_{wrn}$ ), which allows the necessary actions to occur and provides a default (timeout) termination limit. The suppression of slotted responses is accomplished by setting the SWT timer value  $T_{swt}$  to a maximum (default) value, or at least to exceed  $T_{wrn}$ , in which case the net member quits before any response is sent. After the net calling station has used one net address (perhaps NET TUN) to stop and tune the net members, it may send the standard net call NET and trigger the standard slotted responses from the now-tuned stations. This is the primary methodology for a mixed net which includes modern fast-tuning stations plus older generation, slow-tuning (over one second) stations. The net manager, when prearranging the net, assigns a net call such as "NET" to all stations, a subnet call such as "NET TUN" to the slow stations, and directs that a complete net call up should use NET TUN first, wait, then use NET. As an alternative procedure, the net calling station could send a COMMAND Tune and Wait, which causes all net members to tune up and wait for a specified, limited time. After all have tuned (both slow and fast), a standard net call (without the special command) would cause the desired fast responses. See section 80, which also presents several other relevant commands, such as halt and wait, which would be especially useful for a one-way broadcast which does not require responses.

70.6.3 Star group. A star group is a nonprearranged collection of stations which, like a star net, is to link and interoperate primarily with a single "hub" station, which in most cases has the separate function of net control station (NCS). In many cases, little or nothing is known about the stations except their individual addresses and scanned frequencies. Despite this minimum of data, it is critical to be able to create a new group where none existed, and it requires a standardized protocol which is compatible with virtually all stations, essentially regardless of their individual, net, and other characteristics. The purpose of a star group call, like any group call, is to rapidly and efficiently establish contact with multiple nonprearranged (group) stations, simultaneously, by the use of a compact combination of their own addresses which are assigned individually. See 60.5. Unlike the star net call, in which each additional net address has associated with it the necessary slotted response data, a group call cannot have preset slots, because the stations' own individual addresses are used and nothing is prearranged. As will be shown, the group call members derive and construct their own response action, based on the actual received call structure. Basically, the group call protocol is identical in all regards to the net call protocol, except as specified herein.

When a star group calling-type function is required, stations shall use the star group (scanning) calling protocols described herein for all single-channel (and multichannel) calling, polling, and interoperations. The star group (scanning) calling protocol enables rapid and flexible linking with multiple stations without using a common address. See figure A-28. As shown, station A is calling a group of three nonprearranged stations: B, C, and D. All essential parts of star group (scanning) protocol are virtually identical to those of star net (scanning) protocol described previously, and all timing and functional considerations shall apply identically, except as noted herein.



## MIL-STD-188-141A

## APPENDIX A

Considering first the simpler, single-channel case with minimum uniform slots and using single word addresses, the initial group call is modified to incorporate the called station's addresses in the following ways. The calling cycle does not consist of an individual address as in the previously described protocols. In group calling, each called station's whole address is included in the leading call (Tlc) twice in rotation; that is, D, C, and B, then D, C, and B again. See the acknowledgement, at the right, on figure A-28. If a single-channel call is to be made, the first word of the standard leading call (Tlc) would be "TO D" as usual for the individual calling protocol. However, the next address would follow immediately with the standard redundant words (Trw) as "REPEAT C" and then the next "TO B" and similarly until all group whole addresses have been included twice in rotation. The single-channel calling cycle, therefore, consists of all of the redundant whole addresses, rotated through twice. The leading call time, Tlc, is twice the sum ( $\Sigma Ta$ ) of the lengths for all the individual whole address words ( $Ta$ ), (at  $n \times Trw$  each). That is, single-channel  $Tlc = 2 \times$  (sum of all called whole address words)  $\Sigma Ta(m) = 2 \times (NAW \times Trw)$ , where NAW is the number of original individual address words. Obviously, if it were an individual call,  $NAW = 1$ , therefore  $Tlc = 2 Trw$ , as expected.

In this example of a single-channel group call, stations D, C, and B each would hear a call addressed to them and plan to respond. However, they would notice that other station addresses also appear in the calling cycle. Therefore, it must be a group call. Specifically, as shown on figure A-28, a station such as D would hear its address ("TO D") being called. It would plan to respond immediately to whichever station is calling (A), because it appears to be (and at this point is) identical to an individual call. However, upon reading another called address ("REPEAT C"), D realizes that it is actually a group call and slotted responses are required, so D starts to count addresses (starting with his own) until the calling cycle ends. When the "TO B" arrives, D identifies another group-called address and counts to two. If the call repeats, as shown for scanning cases at the left on figure A-28, when "REPEAT D" arrives, D has counted to three. D immediately knows that there are only three stations involved in the group call (D, C, and B). D now must find its slot, so it resets its counter to one (itself). D continues to read the following rotated addresses (C and B again) and continues to count, until the calling cycle ends. Meanwhile, C and B are doing the same thing, and they also determine that three stations (D, C, and B) are involved. However, when counting up to the end of the calling cycle, "THIS IS A" in this case, D reaches three, C reaches two, and B reaches one. They have automatically identified their response slots: D in slot 3, C in slot 2, and B in slot 1. The remainder of the protocol is identical to the star net protocol. Note that if one of the stations, such as C, were to miss the earlier parts of the calling cycle but receive its last "TO C", it would still respond properly in slot 2 because it would read the "REPEAT B" which follows, realize that this is a group call, and should have counted to two by the time the call ended. Similarly, if the last called station heard only the very last words in the calling cycle which were addressed to him, it would mistake it for an individual call and respond immediately (essentially in slot 0) instead of slot 1. Therefore, in a group call, the called stations automatically sort themselves into their proper response slots.

MIL-STD-188-141A

APPENDIX A

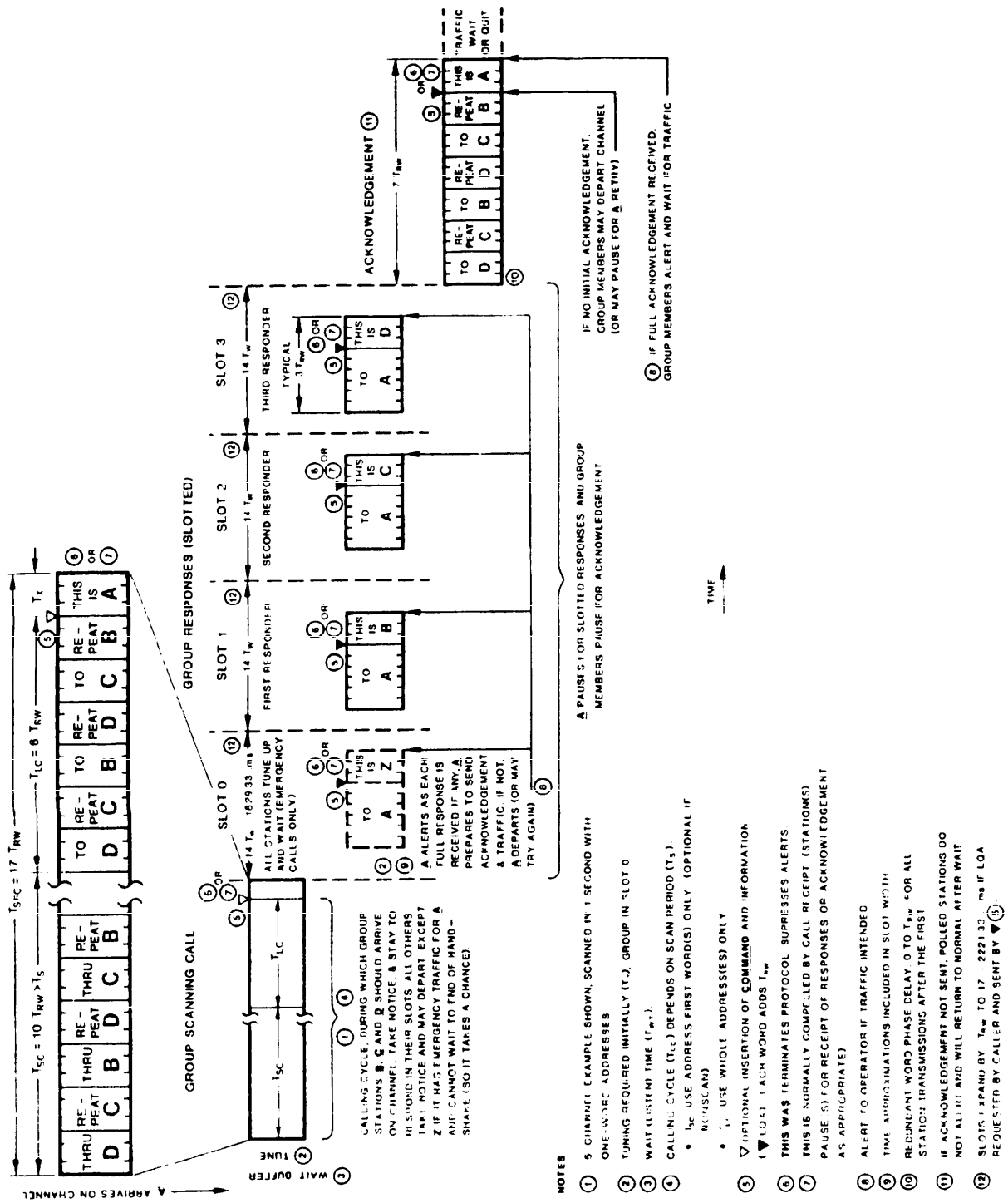

FIGURE A-28. Star group scanning calling protocol.

## MIL-STD-188-141A

## APPENDIX A

In a multichannel scanning group call protocol, the caller call,  $T_{lc}$ , must be lengthened, as in the individual scanning call protocol. In that case,  $T_{cc}$  was increased beyond the basic  $T_{lc}$  by the scan call time  $T_{sc}$ , which was larger than the scan time  $T_s$  of the called station; that is,  $T_{cc} = T_{sc} + T_{lc} = n \times T_d + T_{lc} \geq T_s + T_{lc}$ . Similarly, the  $T_{cc}$  for the scanning group call must increase by a group scan call time  $T_{sc} \geq T_s$ . In the group call, as noted above, the basic leading call,  $T_{lc} = 2T_c = 2 \times$  (sum of all called whole addresses)  $\Sigma T_a(m)$ . The group scan call time,  $T_{sc}$ , shall be composed of a rotated combination ( $T_{cl}$ ) of only the different first words ( $T_{al}$ ) of the called group addresses such that the sum ( $n \times T_{cl}$ ) exceeds  $T_s$  and is a multiple of  $T_{rw}$ . To indicate that this is a group call, the address first word(s), in  $T_{sc}$ , shall be within THRU (and alternating with REPEAT), and in  $T_{lc}$ , shall be in TO (and REPEAT). The addresses first words ( $T_{cl}$ ) rotated in  $T_{sc}$  are not required to be an integral multiple of the addresses in  $T_c$ , as some first words may be duplicated and will be deleted (to produce a minimum set  $T_{cl}$ ). The addresses in both  $T_{sc}$  ( $T_{cl}$ ) and  $T_{lc}$  ( $T_c$ ) shall be rotated in the same basic sequence. Therefore, the scan call time  $T_{sc} = n \times T_{cl} = n \times \Sigma T_{al} \geq T_s = C \times T_d$ , where, as before,  $C$  is the number of channels scanned and  $T_d$  is the potential dwell time on each. Therefore, the total calling cycle time  $T_{cc} = T_{sc} + T_{lc} = 2 \times (NAW \times T_{rw}) + T_{sc} = (n + 2 NAW) \times T_{rw}$ , provided  $n \geq T_s/T_{rw}$ .

Note that  $n$  is any integer sufficient to make the last equation true, and the total number of times address first words ( $T_{al}$ ) are included in the entire scanning call ( $T_{sc}$ ) for the scanning case is  $n$ . Also, when  $T_{sc}$  (and  $T_s$ )  $<$   $T_{cl}$ , it is possible for some addresses to appear only once in the final  $T_{cl}$  period before the end of  $T_{sc}$ . In the example on figure A-24,  $T_s = 3920$  ms,  $n \geq T_s/T_{rw} = 3920/392$ , therefore  $n = 10$ , at least. Since  $NAW = 3$ , the calling cycle  $T_{cc} = (n + 2 NAW) \times T_{rw} = (10 + 6) \times T_{rw} = 16 T_{rw}$ , as shown. The "THIS IS A" terminator of  $T_{rw}$  increases the entire group scanning call to  $17 T_{rw}$ . As can be seen on figure A-24, the multichannel scanning version of the group call only increases the calling cycle by slightly more than the scan time, regardless of the number of stations called in the group. As a standard upper system limit, the maximum group size in a single call has been set at five different address first words ( $T_{cl} \text{ max} = 5 T_{rw} = 1960$  ms), or twelve whole address words in  $T_c$ , which allows up to twelve one-word, six two-word, four three-word, three four-word, or two five-word addresses, or any other combination which does not exceed a rotating address cycle period ( $T_c$ ) (each address once) of  $12 T_{rw}$ .

Unlike the net calls, the slot sizes in group calls are not pretailored for the specific network situation, although as a system minimum uniform standard they shall be  $14 T_{rw}$  wide ( $17 T_{rw}$  with LQA) as described above. These  $14 T_{rw}$  response slots require the basic, single-word, intranet addressing for both calling and called stations, resulting in a  $9 T_{rw}$  wide response, plus adequate propagation and turnaround margins. If the calling station uses a two or more word address for itself, each slot shall be expanded by  $T_{rw}$ , for each address word in excess of one, in addition to optional  $T_{rw}$  expansions, such as for LQA or messages. Similarly, if a particular station is called using an address which uses two or more words, that called station's own slot shall also be expanded by  $T_{rw}$  per address word in excess of one, (in addition to the caller address and any LQA and message expansions). Therefore, all slots



## MIL-STD-188-141A

## APPENDIX A

are automatically adjusted to the proper, minimum necessary width for their associated responses. If any called station arrives on channel late and is unaware of other previously called group stations, it shall be able to derive sufficient information to respond properly. The slotted general formulas for designing nonuniform, nonstandard star net slotted responses ( $T_{sw}$ ,  $T_{swt}$ ,  $T_{wrn}$ ,  $T_{wan}$ ) shall also be used to determine the star group slotted responses.

In the event that a called station does not identify the magnitude of the called group and therefore the correct  $T_{wan}$ , it shall use a default value for  $T_{wan}$  which is equal to the longest permissible group call of twelve one-word addresses. Based on the slotted general formula,  $T_{wan} = 107 T_w + 27 T_a$  (called) + 13  $T_{rw}$  (optional LQA) + 13  $T_m$  (optional message). In the case of no message field and a one-word address caller,  $T_{wrn} \text{ max} = 188 T_w$  (25 seconds), or 277  $T_w$  (30 seconds) with LQA.

In the special but not excluded case where a called station is intended by the caller to use a longer transmission for his response than he can fit in his assigned slot (such as to add a special message), the calling station may insert a "NULL" address in the previous adjacent position in only the leading call of the calling cycle which will provide a "blank" slot for "overflow", immediately following that responder's slot. This overflow slot, typically the minimum width (because "NULL" is a one-word address), provides almost a five additional data-word ( $T_{rw}$ ) capacity. As another special, but not excluded, case, a station may be called multiple times in a group call, even by different addresses, and it shall properly respond in the derived slots as though it were multiple separate stations.

NOTE: The fact that the called station has multiple addresses may not be known to the caller. In some cases, it would be confusing or inappropriate to respond to one but not another address. Redundant calling address conflicts can be resolved after successful linking, if there is a problem.

In the leading call ( $T_{lc}$ ), (when receiving a group call) the preambles TO and REPEAT after TO shall be used to indicate the start of each called station(s) whole addresses. In the scan call ( $T_{sc}$ ), the address first words shall be in alternating THRU and REPEAT. However, if there is only one unique address first word, IT shall be repeated in THRU only, in  $T_{sc}$ .

## MIL-STD-188-141A

## APPENDIX A

## 80. ORDERWIRE MESSAGES.

80.1 Introduction. In addition to automatically establishing links, stations shall have the capability to transfer information within the orderwire, or message, section of the frame. This section describes these messages, including data, control, error checking, networking, and special purpose functions. Table A-XV provides a summary of the COMMAND functions.

NOTE: For critical orderwire messages which require increased protection from interference and noise, several ALE techniques are available. Any message may be specially encoded off-line and then transmitted using the full 128 ASCII COMMAND data text message (DTM) mode (which also accepts random data bits). Larger blocks of information may be Golay FEC coded and deeply interleaved using the COMMAND data block message (DBM) mode. Both modes have an automatic repeat request (ARQ) error-control capability. Integrity of the data may be ensured using the COMMAND CRC mode. See 80.6. In addition, once a link has been established, totally separate equipment, such as heavily coded and robust modems, may be switched onto the rf link in the normal circuit (traffic-bearing) mode.

80.2 Link quality analysis (LQA). This mandatory function is designed to support the exchange of LQA information among ALE stations. The COMMAND LQA word shall be constructed as shown in table A-XVI. The preamble shall be COMMAND (110) in bits P3 through P1 (W1 through W3). The first character shall be "a" (1100001) in bits C1-7 through C1-1 (W4 through W10), which shall identify the LQA function "analysis". It carries three types of analysis information (BER, SINAD, and MP) which are separately generated by the ALE analysis capability. Note that when the control bit KA1 (W11) is set to "1", the receiving station shall respond with an LQA report in the handshake. If KA1 is set to "0", the report is not required, as would be the case for a basic station which is incapable of using the report if received.

80.2.1 Bit error ratio (BER). The mandatory BER shall be empirically derived by all ALE stations from the basic digital signaling, and shall be communicated as follows. The transmitted BER is represented as five bits of information, BE5 through BE1 (W20 through W24). Refer to table A-XII for the assigned values.

80.2.2 Signal plus noise plus distortion to noise plus distortion ratio (SINAD). If the optional SINAD is analytically derived by suitably equipped stations from the ALE analog signaling, it shall be communicated as follows. The SINAD is represented as five bits of information SN5 through SN1 (W15 through W19). The range is 0 to 30 dB in 1-dB steps. 00000 is 0 dB or less, and 11111 is no measurement.

80.2.3 Multipath (MP). Three bits, MP3 through MP1 (W12 through W14), are reserved for multipath information exchange. Until standardized, these bits shall be set to 111 (meaning no measurement available).

## MIL-STD-188-141A

## APPENDIX A

TABLE A-XV. Summary of COMMAND functions.

<u>COMMAND</u>	ABC	(ext. 64)	Automatic message display (AMD) (mandatory). Contains text message for automatic display to the receiving station operator.
<u>COMMAND</u>	a . .	(1100001)	Link quality analysis (LQA) (mandatory). Contains BER, SINAD, MP.
<u>COMMAND</u>	b . .	(1100010)	Data block message (DBM) (optional). Contains compressed text message for automatic output to receiving station I/O port.
<u>COMMAND</u>	d . .	(1100100)	Data text message (DTM) (optional). Contains text message for automatic output to receiving station input/output (I/O) port.
<u>COMMAND</u>	t . .	(1110100)	Time (optional). Contains time and timing information.
<u>COMMAND</u>	x . .	(1111000)	Cyclic redundancy check (CRC) (optional); mandatory with DTM and DBM. Contains error detection information for preceding words.
	y . .	(1111001)	
	z . .	(1111010)	
	{ . .	(1111011)	
<u>COMMAND</u>	. .	(1111100)	User unique functions (UUF) (optional). Contains unique information for a specific user system (special registration).

NOTE: All others are reserved until standardized.

## MIL-STD-188-141A

## APPENDIX A

TABLE A-XVI. Link quality analysis structure.

	LQA bits	Word bits
<u>COMMAND</u> preamble	MSB P3=1 P2=1 LSB P1=0	MSB W1 W2 W3
First character "a"	MSB C1-7=1 C1-6=1 C1-5=0 C1-4=0 C1-3=0 LSB C1-2=0 C1-1=1	W4 W5 W6 W7 W8 W9 W10
Control	KA1	W11
Multipath bits	MSB MP3 MP2 LSB MP1	W12 W13 W14
SINAD bits	MSB SN5 SN4 SN3 SN2 LSB SN1	W15 W16 W17 W18 W19
BER bits	MSB BE5 BE4 BE3 BE2 LSB BE1	W20 W21 W22 W23 LSB W24

## NOTES:

1. COMMAND LQA first character is "a" (1100001) for "analysis".
2. Control bit KA1 (W11) requests an LQA within the handshake from the called station, if set to "1", and suppresses LQA if set to "0".

## MIL-STD-188-141A

## APPENDIX A

80.3 Automatic message display (AMD) mode. The mandatory AMD mode enables stations to communicate short orderwire messages or prearranged codes to any selected station(s). This basic data transfer function exploits the communications, processing, and operator (and controller) interfaces already embedded within the stations and system. The operators and controllers shall be able to send and receive simple ASCII text messages using only the existing station equipment. The entire extended 64 ASCII character subset shall be available for this purpose. The station shall have the capability to both send and receive AMD messages from and to both the operator and the controller. The station shall also have the capability to display any received AMD messages directly to the operator and controller upon arrival, and to alert them. The operator and controller shall have the capability to disable the display and the alarm when their functions would be operationally inappropriate.

When an ASCII short orderwire AMD type function is required, the following COMMAND AMD protocol shall be used, unless another protocol in this standard is substituted. An AMD message shall be constructed in the standard word format, as described herein, and the AMD message shall be inserted in the message section of the frame. Within the AMD structure, the first word shall be a COMMAND AMD word, which shall contain the first three characters of the message. It shall be followed by a sequence of alternating DATA and REPEAT words which shall contain the remainder of the message. The COMMAND, DATA, and REPEAT words shall all contain only characters from the extended ASCII 64 subset, which shall identify them as an AMD transmission. Each separate AMD message shall be kept intact and shall only be sent in a single frame, and in the exact sequence of the message itself. If one or two additional characters are required to fill the triplet in the last word sent, the position(s) shall be "stuffed" with the "space" character (0100000). The end of the AMD message shall be indicated by the start of the frame conclusion, or by the receipt of another COMMAND. Multiple AMD messages may be sent within a frame, but they each shall start with their own COMMAND AMD with the first three characters.

Receipt of the COMMAND AMD word shall warn the receiving station that an AMD message is arriving and shall instruct it to alert the operator and controller and display the message, unless they disable these outputs. The station shall have the capability to distinguish among, and separately display, multiple separate AMD messages which were in one or several transmissions.

The AMD word format shall consist of a COMMAND (110) in bits P3 through P1 (W1 through W3), followed by the three standard character fields C1, C2, and C3. In each character field, each character shall have its most significant bits (MSBs) b7 and b6 (C1-7 and C1-6, C2-7 and C2-6, and C3-7 and C3-6) set to the values of "01" or "10" (that is, all three characters are members of the extended ASCII 64 subset). The rest of the AMD message shall be constructed identically, except for the alternating use of the DATA and REPEAT preambles.

## MIL-STD-188-141A

## APPENDIX A

Any quantity of AMD words may be sent within the message section of the frame, within the  $T_m$  max limitation of 30 words (90 characters). The message characters within the AMD structure shall be displayed verbatim as received. If a detectable information loss or error occurs, the station shall warn of this by the substitution of a unique and distinct error indication, such as all display elements activated (like a "block"). The display shall have a capacity of at least 20 characters (DO: at least 40). The AMD message storage capacity, for recall of the most recently received message(s), shall be at least 90 characters plus sending station address. (DO: at least 400). By operator or controller direction, the display shall be capable of reviewing all messages in the AMD memory and shall also be capable of identifying the originating station's address. If words are received which have the proper AMD format, but are within a portion of the message section under the control of another message protocol (such as DTM), the other protocol shall take precedence and the words shall be ignored by the station's AMD function.

NOTE: If higher data integrity or reliability is required, the COMMAND DTM or DBM protocols should be used.

80.4 Data text message (DTM) mode. The DTM orderwire message function enables stations to communicate (full ASCII, or unformatted binary bits), messages to and from any selected station(s) for direct output to, and input from, associated data terminals or other DTE devices through their standard DCE ports. The DTM data transfer function is a standard speed mode (like AMD) with improved robustness, especially against weak signals and short noise bursts. When used over MF/HF by the ALE system, DTM orderwire messages may be unilateral or bilateral, and broadcast or acknowledged. As the DTM data blocks are of moderate sizes, this special orderwire message function enables utilization of the inherent redundancy and FEC techniques to detect weak HF signals and tolerate short noise bursts.

The DTM data blocks shall be fully buffered at each station and should appear transparent to the using DTEs or data terminals. As a design objective, and under the direction of the operator or controller, the stations should have the capability of using the DTM data traffic mode (ASCII or binary bits) to control switching of the DTM data traffic to the appropriate DCE port or associated DTE equipment, such as to printers and terminals (if ASCII mode), or computers and cryptographic devices (if binary bits mode). As an operator or controller selected option, the received DTM message may also be presented on the operator display, similar to the method for AMD in 80.3.

There are four COMMAND DTM modes: BASIC, EXTENDED, NULL, and ARQ. The DTM BASIC block ranges over a moderate size and contains a variable quantity of data, from zero to full as required, which is exactly measured to ensure integrity of the data during transfer. The DTM EXTENDED blocks are variable over a larger range of sizes, in integral multiples of the ALE basic word, and are filled with integral multiples of message data. The DTM NULL and ARQ modes are used for both link management, and error and flow control. The characteristics of the COMMAND DTM orderwire message functions are listed in table A-XVII and are summarized below:



## MIL-STD-188-141A

## APPENDIX A

<u>COMMAND</u> DTM mode	BASIC	EXTENDED	ARQ NULL
Maximum size, bits	651	7371	0
Cyclic redundancy check	16 bits	16 bits	0
Data capacity, ASCII	0 - 93	3 - 1053, by 3	0
Data capacity, bits	1 - 651	21 - 7371, by 21	0
ALE word redundancy	3 fixed	3 fixed	0
Data transmission	392 ms - 12.152 sec	392 ms - 2.29 min	0

When an ASCII, or binary bit, digital data message function is required, the following COMMAND DTM orderwire structures and protocols shall be used as specified herein, unless another standardized protocol is substituted. The DTM structure shall be inserted within the message section of the standard ALE frame. A COMMAND DTM word shall be constructed in the standard 24-bit format, using the COMMAND preamble. See table A-XVIII. The message data to be transferred shall also be inserted in words, using the DATA and REPEAT preambles. The words shall then be Golay FEC encoded and interleaved, and then shall be transmitted immediately following the COMMAND DTM word. A COMMAND CRC shall immediately follow the data block words, and it shall carry the error control CRC frame check sequence (FCS).

When the DTM structure transmission time exceeds the maximum limit for the message section ( $T_m$  max), the DTM protocol shall take precedence and shall extend the  $T_m$  limit to accommodate the DTM. The DTM mode preserves the required consistency of redundant word phase during the transmission. The message expansion due to the DTM is always a multiple of one  $T_{rw}$ , as the basic ALE word structure is used. The transmission time of the DTM data block (DTM words  $\times$  392 ms) does not include the  $T_{rw}$  for the preceding COMMAND DTM word or the following COMMAND CRC. Figure A-29 shows an example of a DTM message structure.

The DTM protocol shall be as described herein. The COMMAND DTM BASIC and EXTENDED formats (herein referred to as DTM data blocks) shall be used to transfer messages and information among stations. The COMMAND DTM ARQ format shall be used to acknowledge other COMMAND DTM formats and for error and flow control, except for non-ARQ and one-way broadcasts. The COMMAND DTM NULL format shall be used to (a) interrupt ("break") the DTM and message flow, (b) to interrogate stations to confirm DTM capability before initiation of the DTM message transfer protocols, and (c) to terminate the DTM protocols while remaining linked. When used in ALE handshakes and subsequent exchanges, the protocol frame terminations for all involved stations shall be THIS IS until all the DTM messages are successfully transferred, and all are acknowledged if ARQ error control is required. The only exceptions shall be when the protocol is a one-way broadcast or the station is forced to abandon the exchange by the operator or controller, in which cases the termination should be THIS WAS.

## MIL-STD-188-141A

## APPENDIX A

TABLE A-XVII. Data text message characteristics.

	WORD BITS		DTM CODE (DC) DECIMAL (n)	DATA WORDS (w)	BINARY BITS DATA	ASCII CHAR. DATA	DATA TIME	TOTAL DTM (T <sub>rw</sub> )
	W15---W19	W20---W24						
	DTM CODE BITS							
	DC10---DC6	DC5---DC1						
DTM NULL*	0 0 0 0 0	0 0 0 0 0	0	0*	0	0	0	1*
DTM EXTENDED (FULL)	0 0 0 0 0	0 0 0 0 1	1	1	21	3	392 ms	3
	0 0 0 0 0	0 0 0 1 0	2	2	42	6	784 ms	4
	▼▼▼▼▼	▼▼▼▼▼	▼	n	21n	3n	n x 392 ms	n+2
	0 1 0 1 0	1 1 1 1 0	350	350	7350	1050	2.28 min	352
	0 1 0 1 0	1 1 1 1 1	351	351	7371	1053	2.29 min	353
DTM ARQ *	0 1 0 1 1	0 0 0 0 0	352	0*	0	0	0	1*
(RESERVED)*	(12 ≤ m ≤ 31)	0 0 0 0 0	32m	---	---	---	---	---
DTM BASIC (EXACT)	0 1 0 1 1	(01 ≤ p ≤ 31)	352+p	p	(21p+m-31)	3(p-1 to p)	p x 392 ms	p+2
	0 1 1 0 0	▼	384+p	▼	▼	▼	▼	▼
	▼▼▼▼▼	(01 ≤ p ≤ 31)	32m+p	p	(21p+m-31)	3(p-1 to p)	p x 392 ms	p+2
	1 1 1 1 0	▼	960+p	▼	▼	▼	▼	▼
	1 1 1 1 1	(01 ≤ p ≤ 31)	992+p	p	(21p+m-31)	3(p-1 to p)	p x 392 ms	p+2
	(11 ≤ m ≤ 31)	0 0 0 0 1	32m+1	1	1-21	0-3	392 ms	w+2
	▼	0 0 0 1 0	32m+2	2	22-42	3-6	784 ms	w+2
	▼▼▼▼▼	▼▼▼▼▼	32m+p	p	(21p+m-31)	3(p-1 to p)	p x 392 ms	w+2
	1 1 1 1 0	▼	32m+30	30	610-630	87-90	11.760 s	w+2
	(11 ≤ m ≤ 31)	1 1 1 1 1	32m+31	31	631-651	90-93	12.152 s	w+2

## NOTES:

- \* - NO COMMAND CRC USED
- m - BINARY BITS IN LAST WORD + 10
- p - DTM DATA WORDS



## MIL-STD-188-141A

## APPENDIX A

TABLE A-XVIII. Data text message structure.

	DTM bits		Word bits	
	MSB		MSB	
COMMAND preamble		P3 = 1		W1
		P2 = 1		W2
	LSB	P1 = 0		W3
First character "d"	MSB	C1 (bit-7) = 1		W4
		C1 (bit-6) = 1		W5
		C1 (bit-5) = 0		W6
		C1 (bit-4) = 0		W7
		C1 (bit-3) = 1		W9
		C1 (bit-2) = 0		W9
	LSB	C1 (bit-1) = 0		W10
Control bits	MSB	KD4		W11
		KD3		W12
		KD2		W13
	LSB	KD1		W14
DTM data code bits	MSB	DC10		W15
		DC9		W16
		DC8		W17
		DC7		W18
		DC6		W19
		DC5		W20
		DC4		W21
		DC3		W22
		DC2		W23
	LSB	DC1		LSB W24

## NOTES:

1. COMMAND DTM and DTM ARQ first character is "d" for "data".
2. With DTM transmission, control bit KD4 (W11) is set to "0" for no ACK request, and "1" for ACK request.
3. If a DTM ARQ transmission, control bit KD4 (W11) is set to "0" for ACK, and "1" for NAK.
4. With DTM transmission, control bit KD3 (W12) is set to "0" for binary bits, and "1" for 7-bit ASCII characters.
5. If a DTM ARQ transmission, control bit KD3 (W12) is set to "0" for flow continue, and "1" for flow pause.
6. With DTM transmissions, control bit KD2 (W13) is set (a) the same ("0" or "1") as the sequentially adjacent DTM(s) if the transmitted data field is to be reintegrated as part of a larger data text message, and (b) alternately different if independent from the prior adjacent DTM data field(s).
7. If a DTM ARQ transmission, control bit KD2 (W13) is set the same as the referenced DTM transmission.

## MIL-STD-188-141A

## APPENDIX A

TABLE A-XVIII. Data text message structure -- Continued.

NOTES -- Continued:

8. With DTM transmission, control bit KD1 (W14) is set alternately to "0" and "1" in any sequence of DTMs, as a sequence control.
9. If a DTM ARQ transmission, control bit KD1 (W14) is set the same as the referenced DTM transmission.
10. Data code (DC) bits are from table A-XVII.

Once a COMMAND DTM word of any type has been received by a called (addressed) or linked station, the station shall remain on channel for the entire specified DTM data block time (if any), unless forced to abandon the protocol by the operator or controller. The start of the DTM data block itself shall be exactly indicated by the end of the COMMAND DTM BASIC or EXTENDED word itself. The station shall attempt to read the entire DTM data block information in the DATA and REPEAT words, and the following COMMAND CRC, plus the expected frame continuation, which shall contain a conclusion (possibly preceded by additional functions in the message section, as indicated by additional COMMAND words).

With or without ARQ, identification of each DTM data block and its associated orderwire message (if segmented into sequential DTM data blocks) shall be achieved by use of the sequence and message control bits, KD1 and KD2, (as shown in table A-XVIII) which shall alternate with each DTM transmission and message, respectively. The type of data contained within the data block (ASCII or binary bits) shall be indicated by KD3 as a data identification bit. Activation of the ARQ error control protocol shall use the ARQ control bit KD4. If no ARQ is required, such as in one-way broadcasts, multiple DTM data blocks may be sent in the same frame, but they shall be in proper sequential order if they are transferring a segmented message.

When ARQ error or flow control is required, the COMMAND DTM ARQ shall identify the acknowledged DTM data block by the use of the sequence and message control bits KD1 and KD2, which shall be set to the same values as the immediately preceding and referenced DTM data block transmission. Control bit KD3 shall be used as the DTM flow control to pause or continue (or resume) the flow of the DTM data blocks. The acknowledge (ACK) and request-for-repeat (NAK) functions shall use the ARQ control bit KD4. If no ARQ has been required by the sending station, but the receiving station needs to control the flow of the DTM data blocks, it shall use the DTM ARQ to request a pause in, and resumption of, the flow.

When data transfer ARQ error and flow control is required, the DTM data blocks shall be sent individually, in sequence, and each DTM data block shall be acknowledged before the next DTM data block is sent. Therefore, with ARQ there shall be only one DTM data block transmission in each ALE frame. If the transmitted DTM data block causes a NAK in the returned DTM ARQ, as

MIL-STD-188-141A

APPENDIX A

ORIGINAL MESSAGE:

THE QUICK BROWN FOX!

ALE DATA TEXT TRANSMISSION:

WAIT BUFFER (3) TUNES (2)

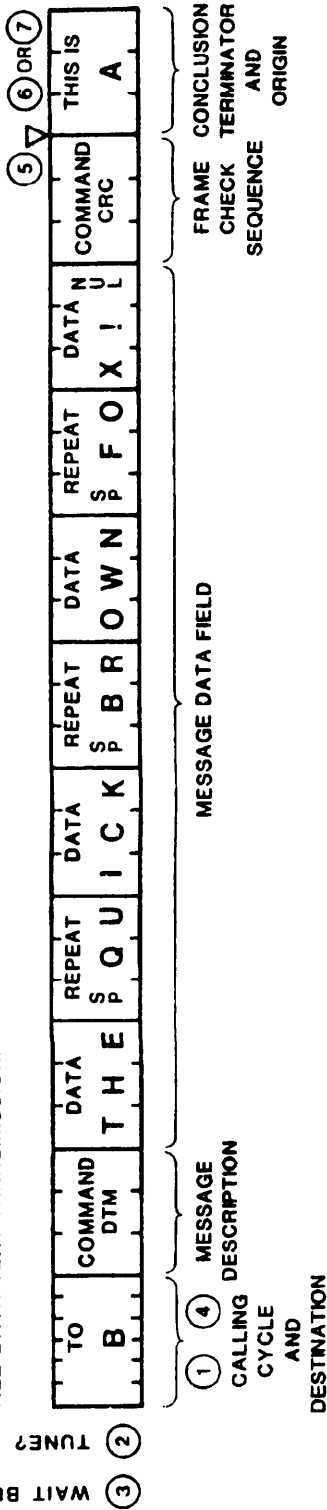

NOTES:

- ① 5-CHANNEL EXAMPLE SHOWN, SCANNED IN 1 SECOND WITH ONE-WORD ADDRESSES.
- ② TUNING REQUIRED INITIALLY ( $T_T$ ).
- ③ WAIT (LISTEN) TIME ( $T_{WT}$ ).
- ④ CALLING CYCLE ( $T_{CC}$ ) DEPENDS ON SCAN PERIOD ( $T_S$ ).
- ⑤ ▽ OPTIONAL INSERTION OF COMMAND AND INFORMATION (▽ LQA). EACH WORD ADDS  $T_{RW}$ .
- ⑥ THIS WAS TERMINATES PROTOCOL. SUPPRESSES ALERTS.
- ⑦ THIS IS NORMALLY COMPELLED BY CALL RECEIPT (A PAUSES FOR AN APPROPRIATE RESPONSE FROM B).

GENERAL NOTES:

- 1. COMMAND DTM IS USED TO INDICATE THE NUMBER OF WORDS IN THE MESSAGE, WHETHER ASCII OR BINARY DATA, AND THE NUMBER OF STUFF BITS IN THE LAST WORD.
- 2. COMMAND CRC CONTAINS FOUR HEXADECIMAL CHARACTERS CONSTITUTING THE 16-BIT FRAME CHECK SEQUENCE.

FIGURE A-29. Data text message structure example.

## MIL-STD-188-141A

## APPENDIX A

described below, or if no ACK or DTM ARQ is detected in the returned frame, or if no ALE frame is detected at all, the sending station shall resend an exact duplicate of the unacknowledged DTM data block. It shall send and continue to resend duplicates (which should be up to at least seven) one at a time and with appropriate pauses for responses, until the involved DTM data block is specifically acknowledged by a correct DTM ARQ. Only then shall the next DTM data block in the sequence be sent. If the sending station is frequently or totally unable to detect ALE frame or DTM ARQ responses, it should abort the DTM transfer protocol, terminate the link, and relink and reinitiate the DTM protocol on a better channel, under operator or controller direction.

Before initiation of the DTM data transfer protocols, the sending stations should confirm the existence of the DTM capability in the intended receiving stations, if not already known. When a DTM interrogation function is required, the following protocol shall be used. Within any standard protocol frame (using THIS IS), the sending station shall transmit a COMMAND DTM NULL, with ARQ required, to the intended station(s). These receiving stations shall respond with the appropriate standard frame and protocol, with the following variations. They shall include a COMMAND DTM ARQ if they are DTM capable, and they shall omit it if they are not DTM capable. The sending station shall examine the ALE and DTM ARQ responses for existence, correctness, and the status of the DTM KD control bits, as described herein. The transmitted COMMAND DTM NULL shall have its control bits set as follows: KD1 and KD2 set opposite of any subsequent and sequential COMMAND DTM BASIC or EXTENDED data blocks which will be transmitted next; KD3 set to indicate the intended type of traffic; and KD4 set to require ARQ. The returned COMMAND DTM ARQ shall have its control bits set as follows: KD1 and KD2 set to match the interrogating DTM NULL; KD3 set to indicate if the station is ready for DTM data exchanges, or if a pause is requested; and KD4 set to ACK if the station is ready to accept DTM data transmissions with the specified traffic type, and NAK if it cannot or will not participate, or it failed to read the DBM NULL.

The sending (interrogating) station shall handle any and all stations which return a NAK, or do not return a DTM ARQ at all, or do not respond at all, in any combination of the following three ways, and for any combination of these stations. The specific actions and stations shall be selected by the operator or controller. The sending station shall: (a) terminate the link with them, using an appropriate and specific call and the THIS WAS terminator; or (b) direct them to remain and stay linked during the transmissions, using the COMMAND STAY protocol in each frame immediately before each COMMAND DTM word and data block sent; or (c) redirect them to do anything else which is controllable using the COMMAND functions described within this standard.

Each received DTM data block shall be examined using the CRC data integrity test which is included within the mandatory associated COMMAND CRC which immediately follows the DTM data block structure. If the data block passes the CRC test, the data shall be passed through to the appropriate DCE port

## MIL-STD-188-141A

## APPENDIX A

(or normal output as directed by the operator or controller). If the data block is part of a larger message which was segmented before DTM transfer, it shall be recombined before output. If any DTM data blocks are received and do not pass the CRC data integrity test, any detectable but uncorrectable errors or areas likely to contain errors, should be tagged for further analysis, error control, or inspection by the operator or controller.

If ARQ is required, the received but unacceptable data block shall be temporarily stored, and a DTM ARQ NAK shall be returned to sender, who shall retransmit an exact duplicate DTM data block. Upon receipt of the duplicate, the receiving station shall again test the CRC. If the CRC is successful, the data block shall be passed through as described before, the previously unacceptable data block should be deleted, and a DTM ARQ ACK shall be returned. If the CRC fails again, both the duplicate and the previously stored data blocks shall be used to correct, as possible, errors and to create an "improved" data block. See figure A-30 for an example of data block reconstruction. The "improved" data block shall then be CRC tested. If the CRC is successful, the "improved" data block is passed through, the previously unacceptable data blocks should be deleted, and a DTM ARQ ACK shall be returned. If the CRC test fails, the "improved" data block shall be stored and a DTM ARQ NAK shall be returned. This process shall be repeated until: (a) a received duplicate, or an "improved" data block passes the CRC test (the data block is passed through, and a DTM ARQ ACK is returned); (b) the maximum number of duplicates (such as seven or more) have been sent without success (with actions by the sender as described above); or (c) the operators or controllers terminate or redirect the DTM protocol.

During reception of ALE frames and DTM data blocks, it is expected that fades, interferences, and collisions will occur. The receiving station shall have the capability to maintain synchronization with the frame and the DTM data block transmission, once initiated. It shall also have the capability to read and process any colliding and significantly stronger (that is, readable) ALE signals without confusing them with the DTM signal (basic ALE reception in parallel, and always listening). Therefore, useful information which may be derived from readable collisions of ALE signals should not be arbitrarily rejected or wasted. The DTM structures, especially the DTM EXTENDED, can tolerate weak signals, short fades, and short noise bursts. For these cases and for collisions, the DTM protocol can detect DTM words which have been damaged and "tag" them for error correction or repeats.

The DTM constructions are described herein. Within the DTM data block structure, a COMMAND DTM word shall be placed ahead of the DTM data block itself. The DTM word shall alert the receiving station that a DTM data block is arriving, how long it is, what type of traffic it contains, what its message and block sequence is, and if ARQ is required. It shall also indicate the exact start of the data block (the end of the COMMAND DTM word), and shall initiate the reception, tracking, decoding, reading, and checking of the message data contained within the data block, which itself is within the DATA and REPEAT words. The message data itself shall be either one of two types, binary bits or ASCII. The ASCII characters (typically used for text) shall be the standard 7-bit length, and the start, stop, and parity bits shall be removed at the sending (and restored at the receiving) station. The binary bits (typically used for other character formats,

MIL-STD-188-141A

APPENDIX A

- ORIGINAL MESSAGE:  
THE QUICK BROWN FOX!
- EACH ALE DATA TRANSMISSION:

TO	COMMAND	DATA	REPEAT	DATA	REPEAT	DATA	REPEAT	DATA	REPEAT	DATA	COMMAND	THIS IS
B	DTM	T H E	\$ Q U I C K	\$ B R O W N	\$ F O X !	N U L	COMMAND	CRC	A			

- FIRST TRY - BROKEN MESSAGE (SEND NAK):  
COMMAND DTM 7 A 7 T H E S U B B S U B B S U B B R O W N \$ F O X ! N U L 2 C 5 B (CRC 9602 REJECT)
- SECOND TRY - BROKEN MESSAGE (SEND NAK):  
COMMAND DTM 7 A 7 T H E S U B B S U B B S U B B S U B B S U B B S U B B (CRC 61E4 REJECT)
- THIRD TRY - BROKEN MESSAGE (SEND ACK, SEE COMBINED OVERLAYS):  
COMMAND DTM 7 A 7 S U B B S U B B S U B B S U B B S U B B S U B B (CRC A712 REJECT)
- COMBINED OVERLAYS ON WORD BASIS, THREE TRIES  
COMMAND DTM 7 A 7 T H E \$ Q U I C K \$ B R O W N \$ F O X ! N U L 2 C 5 B (CRC 2C5B GOOD)
- FINALLY RECEIVED MESSAGE

THE QUICK BROWN FOX!

NOTES:

1. COMMAND DTM IN THIS EXAMPLE INDICATES SEVEN WORDS WITH ASCII CHARACTERS AND SEVEN STUFF BITS IN THE LAST WORD.  
S U
2. B INDICATES SUBSTITUTE CHARACTERS WHEN BAD AND REJECTED.
3. \$ INDICATES SPACE FUNCTION
4. COMMAND CRC CONTAINS FOUR HEXADECIMAL CHARACTERS CONSTITUTING THE 16-BIT FRAME CHECK SEQUENCE.

FIGURE A-30. Data text message reconstruction (overlay).



## MIL-STD-188-141A

## APPENDIX A

computer files, and cryptographic devices) may have any (or no) pattern or format, and they shall be transferred transparently (that is, exactly as they were input to the sending station) with the same length and without modification. The size of the DTM BASIC or EXTENDED data block shall be the smallest multiple of DATA and REPEAT words which will accommodate the quantity of ASCII or binary bits message data to be transferred in the DTM data block. If the message data to be transferred does not exactly fit the unencoded data field of the DTM block size selected, the available empty positions shall be "stuffed" with ASCII "DEL" (1111111) characters or all "1" bits. The combined message and "stuff" data in the unencoded DTM data field shall then be checked by the CRC for error control in the DTM protocol. The resulting 16-bit CRC word shall always be inserted into the COMMAND CRC word which immediately follows the DTM data block words themselves. All the bits in the data field shall then be inserted into standard DATA and REPEAT words, on a 21-bit or 3-character basis, and Golay FEC encoded, interleaved, and tripled for redundancy. Immediately after the COMMAND DTM word, the DTM DATA and REPEAT words shall follow standard word format, and the COMMAND CRC shall be at the end.

The DTM BASIC data block has a relatively compact range of sizes from 0 to 31 words and shall be used to transfer any quantity of message data between zero and the maximum limits for the DTM BASIC structure, which is up to 651 bits or 93 ASCII characters. It is capable of counting the exact quantity of message data which it contains, on a bit-by-bit basis. It should be used as a single DTM for any message data within this range. It shall also be used to transfer any message data in this size range which is an "overflow" from the larger size (and increments) DTM EXTENDED data blocks (which shall immediately precede the DTM BASIC in the DTM sequence of sending).

The DTM EXTENDED data blocks are also variable in size in increments of single ALE words up to 351. They should be used as a single, large DTM to maximize the advantages of DTM throughput. The size of the data block should be selected to provide the largest data field size which can be totally filled by the message data to be transferred. Any "overflow" shall be in a message data segment sent within an immediately following and appropriately sized DTM EXTENDED or BASIC data block. Under operator or controller direction, multiple DTM EXTENDED data blocks, with smaller than the maximum appropriate ID sizes, should be selected if they will optimize DTM data transfer throughput and reliability. However, these multiple data blocks will require that the message data be divided into multiple segments at the sending station, that they shall be sent only in the exact order of the segments in the message, and that the receiving stations must recombine the segments into a complete received message. When binary bits are being transferred, the EXTENDED data field shall be filled exactly to the last bit. When ASCII characters are being transferred, there are no stuff bits as the 7-bit characters fit the ALE word 21-bit data field exactly.

If stations are exchanging DTM data blocks and DTM ARQ's, they may combine both functions in the same frames, and they shall discriminate based on the direction of transmission and the sending and destination addressing. If ARQ is required in a given direction, only one DTM data block shall be allowed within any frame in that direction, and only one DTM ARQ shall be allowed in

## MIL-STD-188-141A

## APPENDIX A

each frame in the return direction. If no ARQ is required in a given direction, multiple DTM data blocks may be included in frames in that direction, and multiple DTM ARQ's may be included in the return direction.

As always throughout the DTM protocol, any sequence of DTM data blocks to be transferred shall have the KD1 sequence control bits alternating with the preceding and following DTM data blocks (except duplicates for ARQ, which shall be exactly the same as the originally transmitted DTM data block).

Also, all multiple DTM data blocks transferring multiple segments of a larger data message shall all have their KD2 message control bits set to the same value, and opposite of the preceding and following messages. If a sequence of multiple but unrelated DTM data blocks are sent (such as several independent and short messages within several DTM BASIC data blocks), they may be sent in any sequence. However, the KD1 and KD2 sequence and message control bits shall alternate with those in the adjacent DTM data blocks.

The COMMAND DTM words shall be constructed as shown in table A-XVIII. The preamble shall be COMMAND (110) in bits P3 through P1 (W1 through W3). The first character shall be "d" (1100100) in bits C1-7 through C1-1 (W4 through W10), which shall identify the DTM "data" function.

For DTM BASIC, EXTENDED, and NULL, when the "ARQ" control bit KD4 (W11) is set to "0", no correct data receipt acknowledgement is required; and when set to "1", it is required. For DTM ARQ, "ARQ" control bit KD4 is set to "0" to indicate acknowledgement or correct data block receipt (ACK); and when set to "1", it indicates a failure to receive the data and is therefore a request-for-repeat (NAK). For DTM ARQ responding to a DTM NULL interrogation, KD4 "0" indicates nonparticipation in the DTM protocol or traffic type, and KD4 "1" indicates affirmative participation in both the DTM protocol and traffic type.

For DTM BASIC, EXTENDED, and NULL, when the "data type" control bit KD3 (W12) is set to "0", the message data contained within the DTM data block shall be binary bits with no required format or pattern; and when KD3 is set to "1" the message data is 7-bit ASCII characters. For DTM ARQ, "flow" control bit KD3 is set to indicate that the DTM transfer flow should continue, or resume; and when KD3 is set to "1" it indicates that the sending station should pause (until another and identical DTM ARQ is returned, except that KD3 shall be "0").

For DTM BASIC, EXTENDED, and NULL, when the "message" control bit KD2 (W13) is set to the same value as the KD2 in any sequentially adjacent DTM data block, the message data contained within those adjacent blocks (after individual error control) shall be recombined with the message data within the present DTM data block to segment-by-segment reconstitute the original whole message; and when KD2 is set opposite to any sequentially adjacent DTM data blocks, those data blocks contain separate message data and shall not be combined. For DTM ARQ, "message" control bit KD2 shall be set to match the referenced DTM data block KD2 value to provide message confirmation.



## MIL-STD-188-141A

## APPENDIX A

For DTM BASIC, EXTENDED, and NULL, the "sequence" control bit KD1 (W14) shall be set opposite to the KD1 value in the sequentially adjacent DTM BASIC, EXTENDED, or NULLs to be sent (the KD1 values therefore alternate, regardless of their message dependencies). When KD1 is set to the same value as any sequentially adjacent DTM sent, it indicates that it is a duplicate (which shall be exactly the same). For DTM ARQ, "sequence" control bit KD1 shall be set to match the referenced DTM data block or NULL KD1 value to provide sequence confirmation.

When used for the DTM protocols, the ten DTM data code (DC) bits DC10 through DC1 (W15 through W24) shall indicate the DTM mode (BASIC, EXTENDED, ARQ, or NULL). They shall also indicate the size of the message data and the length of the data block. The DTM NULL DC value shall be "0" (000000000), and it shall designate the single COMMAND DTM NULL word. The DTM EXTENDED DC values shall range from "1" (000000001) to "351" (010101111), and they designate the COMMAND DTM EXTENDED word and the data block multiple of DATA and REPEAT words which define the variable data block sizes. The EXTENDED sizes shall range from 1 to 351 words, with a range of 21 to 7371 binary bits, in increments of 21, or 3 to 1053 ASCII characters, in increments of 3. The DTM BASIC DC values shall range from "353" (0101100001) to "1023" (111111111), and they shall designate the COMMAND DTM BASIC word and the exact size of the message data in compact and variable size data blocks, with up to 651 binary bits or 93 ASCII characters. The DTM ARQ DC value shall be "352" (0101100000), and it shall designate the single COMMAND DTM ARQ word. The DC values "384" (0110000000) and all higher multiples of "32m" (m x 100000) shall be reserved until standardized. See table A-XVII for DC values and DTM block sizes and other characteristics.

**80.5 Data block message (DBM) mode.** The DBM orderwire message mode enables ALE stations to communicate either full ASCII, or unformatted binary bit messages to and from any selected ALE station(s) for direct output to and input from associated data terminal or other DTE devices through their standard DCE ports. This DBM data transfer function is a high-speed mode (relative to DTM and AMD) with improved robustness, especially against long fades and noise bursts. When used over MF/HF by the ALE system, DBM orderwire messages may be unilateral or bilateral, and broadcast or acknowledged. As the DBM data blocks can be very large, this special orderwire message function enables exploitation of deep interleaving and FEC techniques to penetrate HF-channel long fades and large noise bursts.

The DBM data blocks shall be fully buffered at each station and should appear transparent to the using DTEs or data terminals. As a design objective and under the direction of the operator or controller, the stations should have the capability of using the DBM data traffic mode (ASCII or binary bits) to control switching of the DBM data traffic to the appropriate DCE port or associated DTE equipment, such as to printers and terminals (if ASCII mode) or computers and cryptographic devices (if binary bits mode). As an operator or controller-selected option, the received DBM message may also be presented on the operator display, similar to the method for AMD in 80.3.

## MIL-STD-188-141A

## APPENDIX A

There are four COMMAND DBM modes: BASIC, EXTENDED, NULL, and ARQ. The DBM BASIC block is a fixed size and contains a variable quantity of data, from zero to full as required, which is exactly measured to ensure integrity of the data during transfer. The DBM EXTENDED blocks are variable in size in integral multiples of the BASIC block, and are filled with integral multiples of message data. The DBM NULL and ARQ modes are used for both link management, and error and flow control. The characteristics of the COMMAND DBM orderwire message functions are listed in table A-XIX, and they are summarized below:

<u>COMMAND</u> DBM mode	BASIC	EXTENDED	ARQ, NULL
Maximum size, bits	588	262836	0
Cyclic redundancy check	16 bits	16 bits	0
Data capacity, ASCII	0 - 81	81 - 37545, by 84	0
Data capacity, bits	0 - 572	572 - 262820, by 588	0
Interleaver depth (ID)	49 fixed	49 - 21903, by 49	0
Block transmission	3.136 sec	3.136 sec - 23.36 min, by 3.136 sec increments	0

When an ASCII, or binary bit, digital data message function is required, the following COMMAND DBM orderwire structures and protocols shall be used as specified herein, unless another standardized protocol is substituted. The DBM structure shall be inserted within the message section of the standard frame. A COMMAND DBM word shall be constructed in the standard format. The data to be transferred shall be Golay FEC encoded, interleaved (for error spreading during decoding), and transmitted immediately following the COMMAND DBM word.

When the DBM structure transmission time exceeds the maximum for the message section ( $T_m$  max), the DBM protocol shall take precedence and shall extend the  $T_m$  limit to accommodate the DBM. The DBM mode preserves the required consistency of redundant word phase during the transmission. The message expansion due to the DBM is always a multiple of 49  $T_{rw}$ , as the interleaver depth (ID) is also always a multiple of 49. The transmission time of the DBM data block ( $T_{dbm}$ ) itself is equal to  $(ID \times 64ms)$ , not including the  $T_{rw}$  for the preceding COMMAND DBM word. Figure A-31 shows an example of an exchange using the DBM orderwire to transfer and acknowledge messages. Figure A-32 shows an example of a DBM data interleaver, and figure A-33 shows the transmitted DBM bit-stream sequence.

The DBM protocol shall be as described herein. The COMMAND DBM BASIC and EXTENDED formats (herein referred to as DBM data blocks) shall be used to transfer messages and information among ALE stations. The COMMAND DBM ARQ format shall be used to acknowledge other COMMAND DBM formats and for error and flow control, except for non-ARQ and one-way broadcasts. The COMMAND DBM NULL format shall be used to: (a) interrupt ("break") the DBM and message flow; (b) to interrogate stations to confirm DBM capability before initiation of the DBM message transfer protocols; and (c) to terminate the DBM protocols while remaining linked. When used in handshakes and subsequent exchanges, the protocol frame terminations for all involved stations shall be THIS IS

MIL-STD-188-141A

APPENDIX A

TABLE A-XIX. Data block message characteristics.

	WORD BITS		DBM CODE (DC) DECIMAL (n)	INTER- LEAVE DEPTH (ID)	BINARY BITS DATA	ASCII CHAR DATA	BLOCK TIME	TOTAL DBM (TRW)
	W 15-----W 24	DBM CODE BITS						
	BC 10-----BC 1							
DBM NULL*	0 0 0 0 0 0 0 0 0 0	0	0	0	0	0	0*	1*
DBM EXTENDED (FULL)	0 0 0 0 0 0 0 0 0 1	1	49	572	81	3.136 s	9	
	0 0 0 0 0 0 0 0 1 0	2	98	1160	165	6.272 s	17	
	▼ ▼ ▼ ▼ ▼ ▼ ▼ ▼ ▼ ▼	n	49 n	12 ID-16	BITS ÷ 7	ID x 64 ms	8 n+1	
	0 1 1 0 1 1 1 1 1 0	446	21854	262232	37461	23.31 min	3569	
	0 1 1 0 1 1 1 1 1 1	447	21903	262820	37545	23.36 min	3577	
DBM BASIC (EXACT)	0 1 1 1 0 0 0 0 0 0	448	49	0	0	3.136 s	9	
	0 1 1 1 0 0 0 0 0 1	449	▼	1	0	▼	▼	
	0 1 1 1 0 0 0 0 1 1	450	▼	2	0	▼	▼	
	▼ ▼ ▼ ▼ ▼ ▼ ▼ ▼ ▼ ▼	▼	n-448	▼	BITS ÷ 7	▼	▼	
	1 1 1 1 1 1 1 0 1 1	1019	48	571	81	3.136 s	9	
1 1 1 1 1 1 1 1 0 0	1020	48	572	81	3.136 s	9		
DBM ARQ*	1 1 1 1 1 1 1 1 0 1	1021	0	0	0	0*	1*	
(RESERVED)*	1 1 1 1 1 1 1 1 1 0	1022	---	---	---	---	---	
(RESERVED)*	1 1 1 1 1 1 1 1 1 1	1023	---	---	---	---	---	

NOTE :  
\* NO INTERNAL CRC USED

MIL-STD-188-141A

APPENDIX A

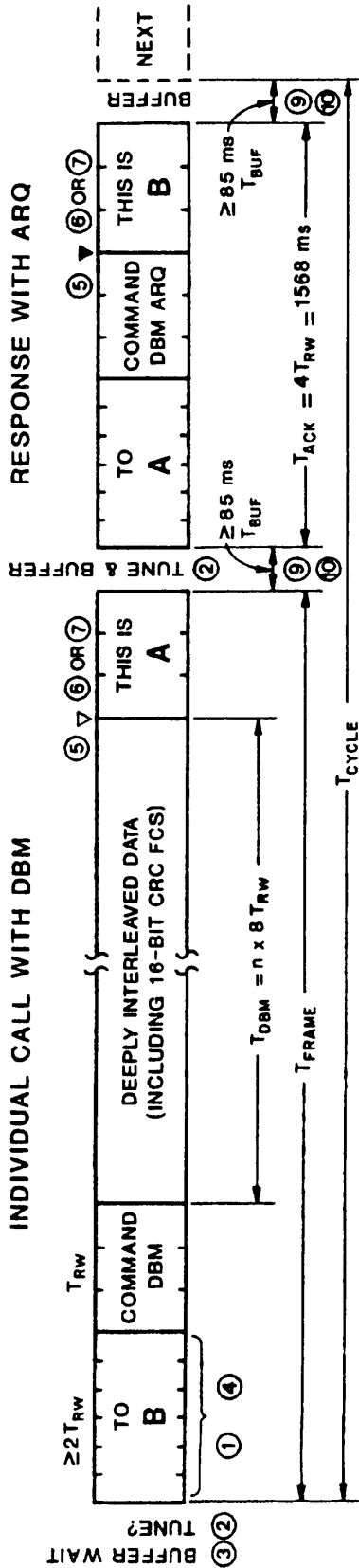

FIGURE A-31. Data block message structure and ARQ example.

NOTES:

- 1-CHANNEL EXAMPLE SHOWN WITH ONE-WORD ADDRESSES.
- TUNING REQUIRED INITIALLY ( $T_T$ ).
- WAIT (LISTEN) TIME ( $T_{WT}$ ).
- CALLING CYCLE ( $T_{CC}$ ) DEPENDS ON SCAN PERIOD ( $T_S$ ).
- OPTIONAL INSERTION OF COMMAND AND INFORMATION (LOA). EACH WORD ADDS  $T_{RW}$ .
- THIS WAS TERMINATES PROTOCOL, SUPPRESSES ALERTS.
- THIS IS NORMALLY COMPELLED BY CALL RECEIPT (A AND B PAUSE FOR AN APPROPRIATE RESPONSE FROM THE OTHER STATION).
- TIME APPROXIMATION, PROPAGATION AND TURNAROUND.
- REDUNDANT WORD PHASE DELAY, 0 TO  $T_{RW}$ . FOR ALL STATION TRANSMISSIONS AFTER THE FIRST.

MIL-STD-188-141A

APPENDIX A

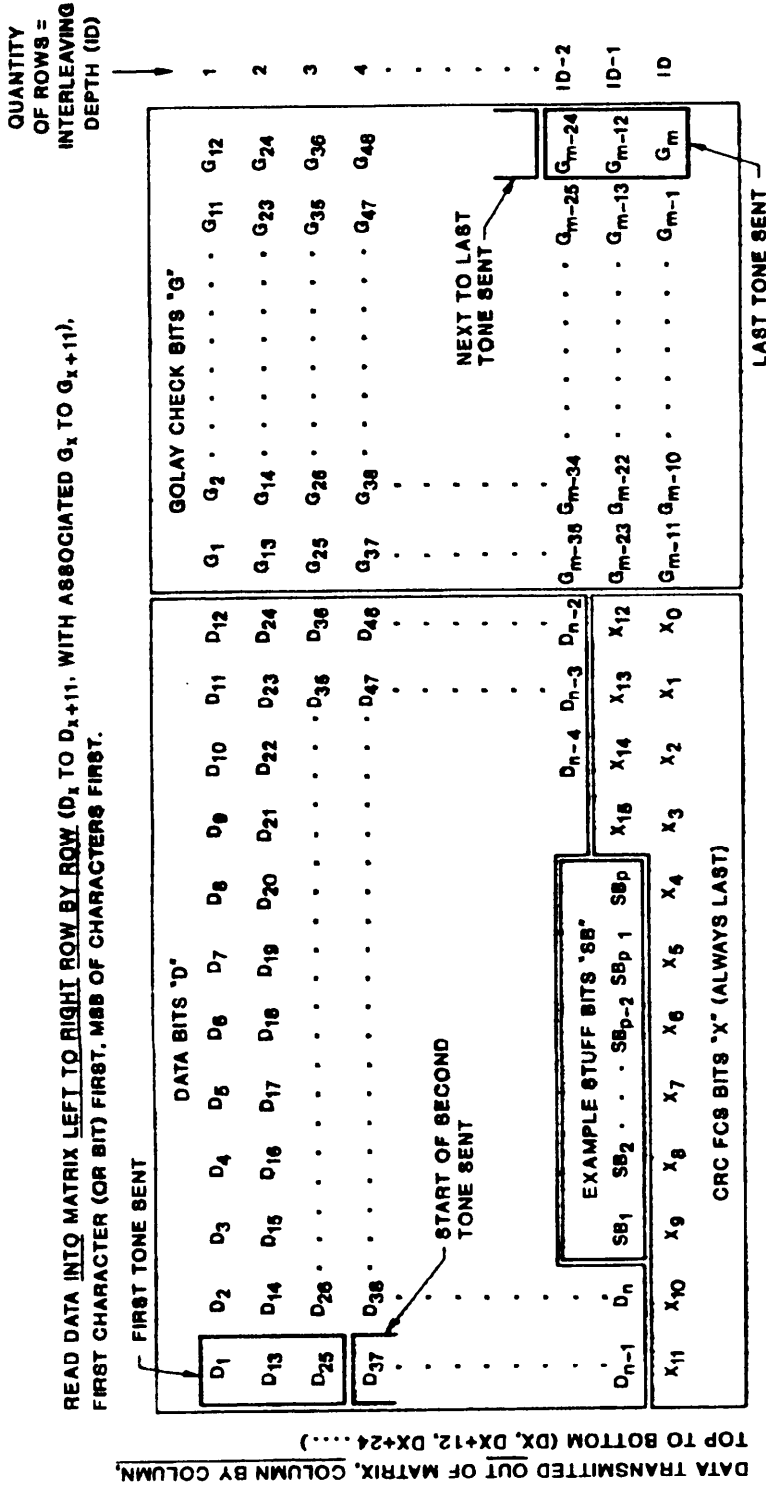

- NOTES:
1. QUANTITY OF CRC FCS BITS (x) = 16.
  2. STUFF BITS (SB) SET TO '1'.
  3. ID IS ALWAYS A MULTIPLE OF 40 TO PRESERVE WORD PHASE.
  4. QUANTITY OF DATA FIELD OR GOLAY CHECK BITS = m = ID x 12.
  5. SIZE OF DATA BLOCK MESSAGE, TOTAL = DATA FIELD BITS & GOLAY CHECK BITS = 2m.
  6. QUANTITY OF DATA BITS = n.
    - IN DBM BASIC: 0 ≤ n ≤ 572.
    - IN DBM EXTENDED: n = ID x 12 FOR BINARY; n = (ID x 12) - P FOR ASCII.
  7. QUANTITY OF STUFF BITS = P = m - n - 16.
    - IN DBM BASIC: 0 ≤ P ≤ 572.
    - IN DBM EXTENDED: P = 0 FOR BINARY; 0 ≤ P ≤ 6 FOR ASCII.

FIGURE A-32. Data block message interleaver and deinterleaver.

MIL-STD-188-141A

APPENDIX A

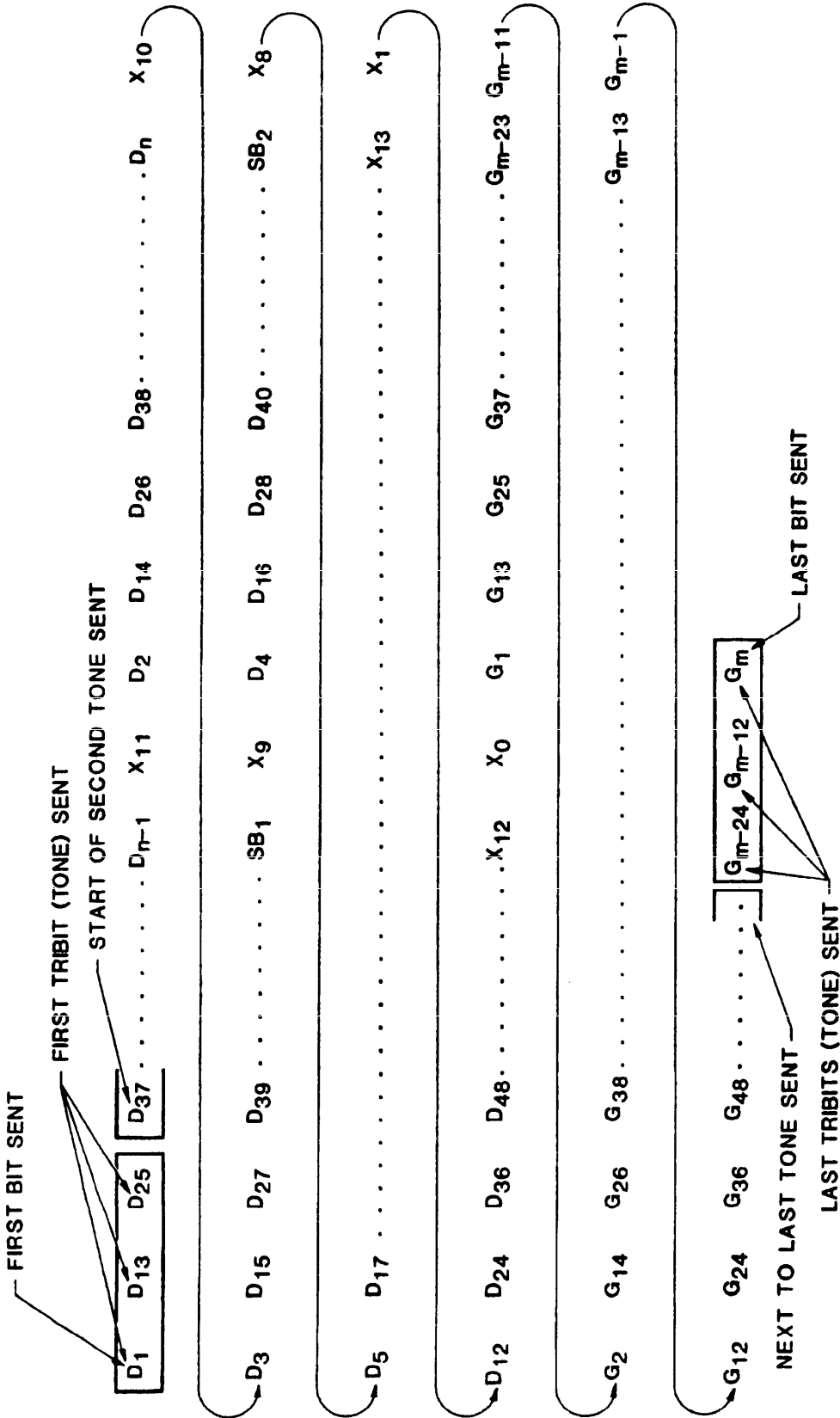

NOTES:

1. QUANTITY OF TONES SENT =  $2m+3 = (2 \times 12 \times ID)+3 = ID \times 8$
2. TIME OF BLOCK SENT =  $ID \times 8 \times 8 \text{ ms} = ID \times 64 \text{ ms}$ .

FIGURE A-33. Data block message example.

## MIL-STD-188-141A

## APPENDIX A

until all the DBM messages are successfully transferred, and all are acknowledged if ARQ error control is required. The only exceptions shall be when the protocol is a one-way broadcast or the station is forced to abandon the exchange by the operator or controller, in which cases the termination should be THIS WAS.

Once a COMMAND DBM word of any type has been received by a called (addressed) or linked station, the station shall remain on channel for the entire specified DBM data block time (if any), unless forced to abandon the protocol by the operator or controller. The start of the DBM data block itself shall be exactly indicated by the end of the COMMAND DBM BASIC or EXTENDED word itself. The station shall attempt to read the entire DBM data block information, plus the expected frame continuation, which shall contain a conclusion (possibly preceded by additional functions in the message section, as indicated by additional COMMAND words).

With or without ARQ, identification of each DBM data block and its associated orderwire message (if segmented into sequential DBM data blocks) shall be achieved by use of the sequence and message control bits, KB1 and KB2 (see table A-XX), which shall alternate with each DBM transmission and message, respectively. The type of data contained within the data block (ASCII or binary bits) shall be indicated by KB3 as a data identification bit. Activation of the ARQ error-control protocol shall use the ARQ control bit KB4. If no ARQ is required, such as in one-way broadcasts, multiple DBM data blocks may be sent in the same frame, but they shall be in proper sequence if they are transferring a segmented message.

When ARQ error or flow control is required, the COMMAND DBM ARQ shall identify the acknowledged DBM data block by the use of the sequence and message control bits KB1 and KB2, which shall be set to the same values as the immediately preceding and referenced DBM data block transmission. Control bit KB3 shall be used as the DBM flow control to pause or continue (or resume) the flow of the DBM data blocks. The ACK and NAK functions shall use the ARQ control bit KB4. If no ARQ has been required by the sending station, but the receiving stations need to control the flow of the DBM data blocks, they shall use the DBM ARQ to request a pause in, and resumption of, the flow.

When data transfer ARQ error and flow control is required, the DBM data blocks shall be sent individually and in sequence. Each DBM data block shall be individually acknowledged before the next DBM data block is sent. Therefore, with ARQ there shall be only one DBM data block transmission in each frame. If the transmitted DBM data block causes a NAK in the returned DBM ARQ, as described below, or if no ACK or DBM ARQ is detected in the returned frame, or if no frame is detected at all, the sending station shall resend an exact duplicate of the unacknowledged DBM data block. It shall continue to resend duplicates (which should be at least seven), one at a time and with appropriate pauses for responses, until the involved DBM data block is specifically acknowledged by a correct DBM ARQ. Only then shall the next DBM data block in the sequence be sent. If the sending station is frequently or totally unable to detect frame or DBM ARQ responses, it should abort the DBM transfer protocol, terminate the link and relink and reinitiate the DBM protocol on a better channel (under operator or controller direction).



## MIL-STD-188-141A

## APPENDIX A

TABLE A-XX. Data block message structure.

COMMAND	DBM bits		Word bits	
	MSB		MSB	
preamble		P3 = 1		W1
		P2 = 1		W2
	LSB	P1 = 0		W3
First character "b"	MSB	C1 (bit-7) = 1		W4
		C1 (bit-6) = 1		W5
		C1 (bit-5) = 0		W6
		C1 (bit-4) = 0		W7
		C1 (bit-3) = 0		W8
		C1 (bit-2) = 1		W9
	LSB	C1 (bit 1) = 0		W10
Control bits	MSB	KB4		W11
		KB3		W12
		KB2		W13
	LSB	KB1		W14
DBM block code bits	MSB	BC10		W15
		BC9		W16
		BC8		W17
		BC7		W18
		BC6		W19
		BC5		W20
		BC4		W21
		BC3		W22
		BC2		W23
		LSB	BC1	

## NOTES:

1. COMMAND DBM and DBM ARQ first character is "b" for "block".
2. With DBM transmission, control bit KB4 (W11) is set to "0" for no ACK request, and "1" for ACK request.
3. If a DBM ARQ transmission, control bit KB4 (W11) is set to "0" for ACK, and "1" for NAK.
4. With DBM transmissions, control bit KB3 (W12) is set to "0" for binary bits, and "1" for 7-bit ASCII characters.
5. If a DBM ARQ transmission, control bit KB3 (W12) is set to "0" for flow continue, and "1" for flow pause.
6. With DBM transmissions, control bit KB2 (W13) is set: (a) the same ("0" or "1") as the sequentially adjacent DBM(s) if the transmitted data field is to be reintegrated as part of a larger data block message; and (b) alternately different if independent from the prior adjacent DBM data field(s).
7. If a DBM ARQ transmission, control bit KB2 (W13) is set the same as the referenced DBM transmission.
8. With DBM transmissions, control bit KB1 (W14) is set alternately to "0" and "1" in any sequence of DBMs as a sequence control.
9. If a DBM ARQ transmission, control bit KB1 (W14) is set the same as the referenced DBM transmission.
10. Block code (BC) bits are from table A-XIX.



## MIL-STD-188-141A

## APPENDIX A

Before initiation of the DBM data transfer protocols, the sending stations should confirm the existence of the DBM capability in the intended receiving stations, if not already known. When a DBM interrogation function is required, the following protocol shall be used. Within any standard protocol frame (using THIS IS), the sending station shall transmit a COMMAND DBM NULL, with ARQ required, to the intended station(s). These receiving stations shall respond with the appropriate standard frame and protocol, with the following variations. They shall include a COMMAND DBM ARQ if they are DBM capable, and they shall omit it if they are not DBM capable. The sending station shall examine the ALE and DBM ARQ responses for existence, correctness, and the status of the DBM KB control bits, as described herein. The transmitted COMMAND DBM NULL shall have its control bits set as follows: KB1 and KB2 set opposite of any subsequent and sequential COMMAND DBM BASIC or EXTENDED data blocks which will be transmitted next; KB3 set to indicate the intended type of traffic; and KB4 set to require ARQ. The returned COMMAND DBM ARQ shall have its control bits set as follows: KB1 and KB2 set to match the interrogating DBM NULL; KB3 set to indicate if the station is ready for DBM data exchanges, or if a pause is requested; and KB4 set to ACK if the station is ready to accept DBM data transmissions with the specified traffic type, and NAK if it cannot or will not participate, or if it failed to read the DBM NULL.

The sending (interrogating) station shall handle any stations which return a NAK, or do not return a DBM ARQ, or do not respond, in any combination of the following, and for any combination of these stations. The specific actions and stations shall be selected by the operator or controller. The sending station shall: (a) terminate the link with these stations, using an appropriate and specific call and the THIS WAS terminator; (b) direct the stations to remain and stay linked during the transmissions, using the COMMAND STAY protocol in each frame immediately before each COMMAND DBM word and data block sent; or (c) redirect them to do anything else which is controllable using the COMMAND functions described within this standard.

Each received DBM data block shall be examined using the CRC data integrity test which is embedded within the DBM structure and protocol. If the data block passes the CRC test, the data shall be passed through to the appropriate DCE port (or normal output as directed by the operator or controller). If the data block is part of a larger message which was segmented before DBM transfer, it shall be recombined before output. If any DBM data blocks are received and do not pass the CRC data integrity test, any detectable but uncorrectable errors, or areas likely to contain errors, should be tagged for further analysis, error control, or inspection by the operator or controller.

If ARQ is required, the received but unacceptable data block shall be temporarily stored, and a DBM ARQ NAK shall be returned to the sender, who shall retransmit an exact duplicate DBM data block. Upon receipt of the duplicate, the receiving station shall again test the CRC. If the CRC is successful, the data block shall be passed through as described before, the previously unacceptable data block should be deleted, and a DBM ARQ ACK shall be returned. If the CRC fails again, both the duplicate and the previously stored data blocks shall be used to correct, as possible, errors and to create an "improved" data block. See figure A-30 for an example of data

## MIL-STD-188-141A

## APPENDIX A

block reconstruction. The "improved" data block shall then be CRC tested. If the CRC is successful, the "improved" data block is passed through, the previously unacceptable data blocks should be deleted, and a DBM ARQ ACK shall be returned. If the CRC test fails, the "improved" data block shall also be stored and a DBM ARQ NAK shall be returned. This process shall be repeated until: (a) a received duplicate, or an "improved" data block passes the CRC test (and the data block is passed through, and a DBM ARQ ACK is returned); (b) the maximum number of duplicates (such as seven or more) have been sent without success (with actions by the sender as described above); or (c) the operators or controllers terminate or redirect the DBM protocol.

During reception of frames and DBM data blocks, it is expected that fades, interferences, and collisions will occur. The receiving station shall have the capability to maintain synchronization with the frame and the DBM data block transmission, once initiated. It shall also have the capability to read and process any colliding and significantly stronger (that is, readable) ALE signals without confusing them with the DBM signal (basic ALE reception in parallel, and always listening). The DBM structures, especially the DBM EXTENDED, can tolerate significant fades, noisebursts, and collisions. Therefore, useful information which may be derived from readable collisions of ALE signals should not be arbitrarily rejected or wasted.

The DBM constructions shall be as described herein. Within the DBM data block structure, a COMMAND DBM word shall be placed ahead of the encoded and interleaved data block itself. The DBM word shall alert the receiving station that a DBM data block is arriving, how long it is, what type of traffic it contains, what its ID is, what its message and block sequence is, and if ARQ is required. It shall also indicate the exact start of the data block itself (the end of the COMMAND DBM word itself) and shall initiate the reception, tracking, deinterleaving, decoding, and checking of the data contained within the block. The message data itself shall be either one of two types, binary bits or ASCII. The ASCII characters (typically used for text) shall be the standard 7-bit length, and the start, stop, and parity bits shall be removed at the sending (and restored at the receiving) station. The binary bits (typically used for other character formats, computer files, and cryptographic devices) may have any (or no) pattern or format, and they shall be transferred transparently, that this, exactly as they were input to the sending station, with the same length and without modification. The value of the ID shall be the smallest (multiple of 49) which will accommodate the quantity of ASCII or binary bits message data to be transferred in that DBM data block. If the message data to be transferred does not exactly fit the uncoded data field of the DBM block size selected (except for the last 16 bits, which are reserved for the CRC), the available empty positions shall be "stuffed" with ASCII "DEL" characters or all "1" bits. The combined message and "stuff" data in the uncoded DBM data field shall then be checked by the CRC for error control in the DBM protocol. The resulting 16-bit CRC word shall always occupy the last 16 bits in the data field. All the bits in the field shall then be Golay FEC encoded, on a 12-bit basis, to produce rows of 24-bit code words, arranged from top to bottom in the interleaver matrix (or equivalent), as shown on figure A-32. The bits in the matrix are then read out by columns (of length equal to the ID) for transmission. Immediately after the COMMAND DBM word, the encoded and interleaved data blocks bits shall follow in bit format, three bits per symbol (tone).

## MIL-STD-188-141A

## APPENDIX A

The DBM BASIC data block has a fixed size (ID 49) and shall be used to transfer any quantity of message data between zero and the maximum limits for the DBM BASIC structure, which is up to 572 bits or 81 ASCII characters. It is capable of counting the exact quantity of message data which it contains, on a bit-by-bit basis. It should be used as a single DBM for any message data within this range. It shall also be used to transfer any message data in this size range which is an "overflow" from the larger size (and increments) DBM EXTENDED data blocks (which shall immediately precede the DBM BASIC in the DBM sequence of sending).

The DBM EXTENDED data blocks are variable in size, in increments of 49 times the ID. They should be used as a single, large DBM to maximize the advantages of DBM deep interleaving, FEC techniques, and higher speed (than DTM or AMD) transfer of data. The ID of the EXTENDED data block should be selected to provide the largest data field size which can be totally filled by the message data to be transferred. Any "overflow" shall be in a message data segment sent within an immediately following DBM EXTENDED or BASIC data block. Under operator or controller direction, multiple DBM EXTENDED data blocks, with smaller than the maximum appropriate ID sizes, should be selected if they will optimize DBM data transfer throughput and reliability. However, these multiple data blocks will require that the message data be divided into multiple segments at the sending station and sent only in the exact order of the segments in the message. The receiving stations must recombine the segments into a complete received message. When binary bits are being transferred, the EXTENDED data field shall be filled exactly to the last bit. When ASCII characters are being transferred, the EXTENDED data field may have 0 to 6 "stuff" bits inserted. Individual ASCII characters shall not be split between DBM data blocks and the receiving station shall read the decoded data field on a 7-bit basis, and it shall discard any remaining "stuff" bits (modulo-7 remainder).

If stations are exchanging DBM data blocks and DBM ARQs, they may combine both functions in the same frames. They shall discriminate based on the direction of transmission and the sending and destination addressing. If ARQ is required in a given direction, only one DBM data block shall be allowed within any frame in that direction, and only one DBM ARQ shall be allowed in each frame in the return direction. If no ARQ is required in a given direction, multiple DBM data blocks may be included in frames in that direction, and multiple DBM ARQs may be included in the return direction.

As always throughout the DBM protocol, any sequence of DBM data blocks to be transferred shall have their KB1 sequence control bits alternating with the preceding and following DBM data blocks (except duplicates for ARQ, which shall be exactly the same as their originally transmitted DBM data block). Also, all multiple DBM data blocks transferring multiple segments of a larger data message shall all have their KB2 message control bits set to the same value, and opposite of the preceding and following messages. If a sequence of multiple but unrelated DBM data blocks are sent (such as several independent and short messages within several DBM BASIC data blocks), they may be sent in any sequence. However, when sent, the associated KB1 and KB2 sequence and message control bits shall alternate with those in the adjacent DBM data blocks.

## MIL-STD-188-141A

## APPENDIX A

The COMMAND DBM words shall be constructed as shown in table A-XX. The preamble shall be COMMAND (110) in bits P3 through P1 (W1 through W3). The first character shall be "b" (1100010) in bits C1-7 through C1-1 (W4 through W10), which shall identify the DBM "block" function.

For DBM BASIC, EXTENDED, and NULL, when the ARQ control bit KB4 (W11) is set to "0" no correct data receipt acknowledgement is required; and when set to "1" it is required. For DBM ARQ, ARQ control bit KB4 is set to "0" to indicate acknowledgement or correct data block receipt (ACK); and when set to "1" it indicates a failure to receive the data and is therefore a request-for-repeat (NAK). For DBM ARQ responding to a DBM NULL interrogation, KB4 "0" indicates nonparticipation in the DBM protocol or traffic type, and KB4 "1" indicates affirmative participation in both the DBM protocol and traffic type.

For DBM BASIC, EXTENDED, and NULL, when the data type control bit KB3 (W12) is set to "0", the message data contained within the DBM data block shall be binary bits with no required format or pattern; and when KB3 is set to "1", the message data is 7-bit ASCII characters. For DBM ARQ, flow control bit KB3 is set to "0" to indicate that the DBM transfer flow should continue or resume; and when KB3 is set to "1", it indicates that the sending station should pause (until another and identical DBM ARQ is returned, except that KB3 shall be "0").

For DBM BASIC, EXTENDED, and NULL, when the "message" control bit KB2 (W13) is set to the same value as the KB2 in any sequentially adjacent DBM data block, the message data contained within those adjacent blocks (after individual error control) shall be recombined with the message data within the present DBM data block to reconstitute (segment-by-segment) the original whole message; and when KB2 is set opposite to any sequentially adjacent DBM data blocks, those data blocks contain separate message data and shall not be combined. For DBM ARQ, "message" control bit KB2 shall be set to match the referenced DBM data block KB2 value to provide message confirmation.

For DBM BASIC, EXTENDED, and NULL, the sequence control bit KB1 (W14) shall be set opposite to the KB1 value in the sequentially adjacent DBM BASIC, EXTENDED, or NULLs to be sent (the KB1 values therefore alternate, regardless of their message dependencies). When KB1 is set the same as any sequentially adjacent DBM sent, it indicates a duplicate. For DBM ARQ, sequence control bit KB1 shall be set to match the referenced DBM data block or NULL KB1 value to provide sequence confirmation.

When used for the DBM protocols, the ten DBM block code (BC) bits BC10 through BC1 (W15 through W24) shall indicate the DBM mode (BASIC, EXTENDED, ARQ, or NULL). They shall also indicate the size of the message data and the length of the data block. The DBM NULL BC value shall be "0" (0000000000), and it shall designate the single COMMAND DBM NULL word. The DBM EXTENDED BC values shall range from "1" (0000000001) to "447" (0110111111), and they shall designate the COMMAND DBM EXTENDED word and the data block multiple (of 49 ID) which defines the variable data block sizes, in increments of 588 binary bits or 84 ASCII characters. The DBM BASIC BC values shall range from "448" (0111000000) to "1020" (1111111100), and they shall designate the



## MIL-STD-188-141A

## APPENDIX A

COMMAND DBM BASIC word and the exact size of the message data in a fixed size (ID = 49) data block, with up to 572 binary bits or 81 ASCII characters. The DBM ARQ BC value shall be "1021" (1111111101), and it shall designate the single COMMAND DBM ARQ word. The BC values "1022" (1111111110) and "1023" (1111111111) shall be reserved until standardized. See table A-XIX.

80.6 Cyclic redundancy check (CRC). This special error-checking function is available to provide data integrity assurance for any form of message in an ALE call.

NOTE: The CRC function is optional, but mandatory when used with the DTM or DBM modes.

The sixteen-bit frame check sequence (FCS) and method as specified by FED-STD 1003, shall be used herein. The FCS provides a probability of undetected error of  $2^{-16}$ , independent of the number of bits checked. The generator polynomial is

$$x^{16} + x^{12} + x^5 + 1$$

and the sixteen FCS bits are designated

$$\text{(MSB)} x^{15}, x^{14}, x^{13}, x^{12} \dots x^1, x^0 \text{ (LSB)}.$$

The ALE CRC is employed two ways: within the DTM data words, and following the DBM data field, described in 80.4 and 80.5, respectively. The first, and the standard, usages are described in this section.

The COMMAND CRC word shall be constructed as shown in table A-XXI. The preamble shall be COMMAND (110) in bits P3 through P1 (W1 through W3). The first character shall be "x" (1111000), "y" (1111001), "z" (1111010), or "{" (1111011) in bits C1-7 through C1-1 (W4 through W10). Note that four identifying characters result from FCS bits  $x^{15}$  and  $x^{14}$  which occupy C1-2 and C1-1 (W9 and W10) in the first character field respectively. The conversion of FCS bits to and from ALE CRC format bits shall be as described in table A-XXI where  $x^{15}$  through  $x^0$  correspond to W9 through W24.

The COMMAND CRC message should normally appear at the end of the message section of a transmission, but it may be inserted within the message section (but not within the message being checked) any number of times for any number of separately checked messages, and at any point except the first word (except as noted below). The CRC analysis shall be performed on all ALE words in the message section which precede the COMMAND CRC word bearing the FCS information, and which are bounded by the end of the calling cycle, or the previous COMMAND CRC word, whichever is closest. The selected ALE words shall be analyzed in their nonredundant and unencoded (or FEC decoded) basic ALE word (24-bit) form in the bit sequence (MSB) W1, W2, W3, W4...W24 (LSB), followed by the unencoded bits W1 through W24 from the next word sent (or received), followed by the bits of the next word, until the first COMMAND CRC is inserted (or found). Therefore, each COMMAND CRC inserted and sent in the message section ensures the data integrity of all the bits in the previous

## MIL-STD-188-141A

## APPENDIX A

TABLE A-XXI. Cyclic redundancy check structure.

	CRC bits		Word bits	
	MSB	LSB	MSB	LSB
COMMAND preamble	P3=1	P1=0	W1	W3
First character(s) "x,y,z,{"	(c) MSB	C1-7 = 1	W4	
		C1-6 = 1	W5	
		C1-5 = 1	W6	
		C1-4 = 1	W7	
		C1-3 = 0	W8	
	(x) MSB	C1-2 = x <sup>15</sup>	W9	
	(c) LSB	C1-1 = x <sup>14</sup>	W10	
		x <sup>13</sup>	W11	
		x <sup>12</sup>	W12	
		x <sup>11</sup>	W13	
		x <sup>10</sup>	W14	
		x <sup>9</sup>	W15	
		x <sup>8</sup>	W16	
		x <sup>7</sup>	W17	
		x <sup>6</sup>	W18	
	x <sup>5</sup>	W19		
	x <sup>4</sup>	W20		
	x <sup>3</sup>	W21		
	x <sup>2</sup>	W22		
	x <sup>1</sup>	W23		
(x) LSB	x <sup>0</sup>	W24		

## NOTES:

- COMMAND CRC first character is one of four, "x" (1111000), "y" (1111001), "z" (1111010), or "{" (1111011), depending on CRC bits x<sup>15</sup> and x<sup>14</sup>, which are also C1-2 and C1-1, respectively.
- "x<sup>n</sup>" indicates FCS bits.

## MIL-STD-188-141A

## APPENDIX A

checked ALE words, including their preambles. If it is necessary to check the ALE words in the calling cycle (TO) preceding the message section, an optional calling cycle COMMAND CRC shall be used as the calling cycle terminator (first FROM or COMMAND), shall therefore appear first in the message section, and shall analyze the calling cycle words in their simplest (Tc), nonredundant and nonrotated form. If it is necessary to check the words in a conclusion (THIS IS or THIS WAS), an optional conclusion CRC shall directly precede the conclusion portion of the call, shall be at the end of the message section, and shall itself be directly preceded by a separate COMMAND CRC (which may be used to check the message section or calling cycle, as described herein). Stations shall perform CRC analysis on all received ALE transmissions and shall be prepared to compare analytical FCS values with any COMMAND CRC words which may be received. If a CRC FCS comparison fails, an automatic (or operator initiated) retransmission request (ARQ) or other appropriate procedure may be used to correct the message, as may be defined in this standard.

80.7 Tune and wait. The COMMAND tune and wait special control function directs the receiving station(s) to perform the initial parts of the handshake, up through tuneup, and wait on channel for further instructions during the specified time limit. The time limit timer is essentially the WRTT wait for response and tune timer, as used in net slotted responses where its value  $T_{wrn}$  is set by the timing information in the special control instruction, and it starts from the detected end of the call. The COMMAND tune and wait instruction shall suppress any normal or preset responses. Except for the tuneup itself, the receiving station(s) shall make no additional emissions, and they shall quit the channel and resume scan if no further instructions are received.

NOTE: This special control function enables very slow tuning stations, or stations which must wait for manual operator interaction, to effectively interface with automated networks.

The COMMAND tune and wait shall be constructed as follows and as shown in table A-XXII. The preamble shall be COMMAND (110) in bits P3 through P1 (W1 through W3). The first character (C1) shall be "t" (1110100) in bits C1-7 through C1-1 (W4 through W10) and "t" (1110100) in bits C2-7 through C2-1 (W11 through W17), for "time, tuneup." The "T" time bits TB7 through TB1 (W18 through W24) shall be values selected from table A-XXIII, and limited as shown in table A-XXIV. The lowest value (00000) shall cause the tuning to be performed immediately, with zero waiting time, resulting in immediate return to normal scan after tuning.

80.8 Time-related special functions for all COMMANDs. These special control functions permit the manipulation of timing in the ALE system. They are based on the standard "T" time values, presented in table A-XXIII, which have the following ranges based on exact multiples of  $T_w$  (130.66... ms) or  $Tr_w$  (392 ms).

- o 0 to 4 seconds in 1/8 second ( $T_w$ ) increments
- o 0 to 36 seconds in 1 second ( $3 Tr_w$ ) increments
- o 0 to 31 minutes in 1 minute ( $153 Tr_w$ ) increments
- o 0 to 29 hours in 1 hour ( $9184 Tr_w$ ) increments

## MIL-STD-188-141A

## APPENDIX A

TABLE A-XXII. Tune and wait structure.

	Tune and wait bits		Word bits
COMMAND preamble	MSB	P3 = 1	MSB W1
	LSB	P2 = 1 P1 = 0	W2 W3
First character "t"	MSB	C1-7 = 1	W4
		C1-6 = 1	W5
		C1-5 = 1	W6
		C1-4 = 0	W7
		C1-3 = 1	W8
	LSB	C1-2 = 0 C1-1 = 0	W9 W10
Second character "t"	MSB	C2-7 = 1	W11
		C2-6 = 1	W12
		C2-5 = 1	W13
		C2-4 = 0	W14
		C2-3 = 1	W15
	LSB	C2-2 = 0 C2-1 = 0	W16 W17
Time bits	MSB	TB7	W18
		TB6	W19
		TB5	W20
		TB4	W21
		TB3	W22
		TB2	W23
	LSB	TB1	LSB W24

## NOTES:

1. COMMAND tune and wait first two characters are "t" (1110100) and "t" (1110100) for "time tuneup."
2. Time bits TB7 through TB1 from table A-XXIII.



## MIL-STD-188-141A

## APPENDIX A

TABLE A-XXIII. Time values.

MULTIPLIER: Most significant bits (MSBs)									
MSB TB7 (W18)				TB6 (W19)	Exact increment		Approximate increment		Approximate range of "T" values
0				0	Tw 130.66... ms		1/8 second		0 - 4 seconds
0				1	3 Trw 1176 ms		1 second		0 - 36 seconds
1				0	153 Trw 59.976 sec		1 minute		0 - 31 minutes
1				1	9184 Trw 60.002 min		1 hour		0 - 29 hours
INDEX: Least significant bits (LSBs)									
TB5 (W20)	TB4 (W21)	TB3 (W22)	TB2 (W23)	LSB TB1 (W24)	Index value	"T" value for MSB=00	"T" value for MSB=01	"T" value for MSB=10	"T" value for MSB=11
0	0	0	0	0	0	0(1)	0	0	0
0	0	0	0	1	1	130.66ms	1.176s	1.00min	1.00hr
0	0	0	1	0	2	261.33ms	2.352s	2.00min	2.00hr
0	0	0	1	1	3	392.00ms	3.528s	3.00min	3.00hr
0	0	1	0	0	4	523.66ms	4.204s	4.00min	4.00hr
0	0	1	0	1	5	653.33ms	5.880s	5.00min	5.00hr
.	.	.	.	.	.	.	.	.	.
.	.	.	.	.	.	.	.	.	.
1	1	1	0	1	29	3789.3ms	34.10s	29.0min	29.0hr
1	1	1	1	0	30	3920.0ms	35.28s	30.0min	(3)
1	1	1	1	1	31	4050.7ms	36.46s	31.0min	(2)

## NOTES:

1. The minimum value "0" (TB = 0000000) is interpreted as "do immediately" if a delay, or "zero size" if a time width, as specified in usage.
2. The maximum value "127" (TB = 1111111) is interpreted as "do it at time or date following," as specified in next COMMAND.
3. The next maximum value "126" (TB = 1111110) is interpreted as "indefinite time," unlimited except by other COMMAND or timeout protocol.

## MIL-STD-188-141A

## APPENDIX A

TABLE A-XXIV. Time-related COMMAND functions.

Identification	First character	Second character	Function
Adjust slot width	"t"	"a" (1100001)	Add T to width of all slots for this response. TB=0, normal. TB7 = 0 as 36 second limit.
Halt and wait	"t"	"h" (1101000)	Stop scan on channel, do not tune or respond, wait T for instruction; quit and resume scan if nothing. TB = 0, quit after call. TB7 = 0 as 36 second limit.
Operator NAK	"t"	"n" (1101110)	Same as "t,o" operator ACK, except that at T, if no input, automatic tuneup and respond NAK (THIS IS), in slots if any. TB = 0, NAK now.
Operator ACK	"t"	"o" (1101111)	Stop scan, alert operator to manually input ACK (or NAK), which causes tuneup (if needed) and ACK response <u>THIS WAS</u> , or <u>THIS IS</u> ; if no input by operator by T, simply quit. TB = 0, ACK now. TB7 = 0 as 36 second time limit. TB = 111111, do at date/time following.
Respond and wait	"t"	"r" (1110010)	Stop scan, tuneup and respond as normal, wait T for instructions, quit and resume scan if nothing. TB = 0, quit after response. TB7 = 0 as 36 second limit. TB = 111111, do at date/time following.
Stay	"t"	"a" ( $\leq 0011111$ )	Wait on channel for time T and stay linked, don't transmit unless commanded, and ignore all signals during T if not understood; expect ALE frame reacquisition by T (must be in correct redundant word phase). T in multiples of Trw, as indicated by binary value of last 14 bits ( $\leq 0011111 1111111 = 4095$ s), range of 0 to 26.754 minutes.

## MIL-STD-188-141A

## APPENDIX A

TABLE A-XXIV. Time-related COMMAND functions -- Continued.

<u>Identification</u>	<u>First character</u>	<u>Second character</u>	<u>Function</u>
Tune and wait	"t"	"t" (1110100)	Stop scan, tuneup, do not respond, wait T for instructions, quit and resume scan if nothing. TB = 0, quit after tuneup. TB7 = 0 as 36 second limit.
Width of slots	"t"	"w" (1110111)	Set all slots to T wide for this response. TB = 0, no responses. TB7 = 0 as 36-second limit.

## NOTES:

1. Preamble is COMMAND (110).
2. First character is "t" (1110100) for all.
3. Third-character field is binary bits TB7 through TB1 (W18 through W24), designating a time interval "T" as a standardized value in table A-XXIII.

and protocol resumes, to ensure synchronization. The STAY function preserves maintenance of the frame and link. It instructs the stations to wait, because the amount of time occupied by the UUF activity or its signaling may conflict with functions such as the wait-for-activity timer (Twa). This may interfere with the protocols or maintenance of the link. In any case, the users of the UUF shall be responsible for noninterference with other stations and users, and also for controlling their own stations and link management functions to avoid these conflicts.

The user unique function (UUF) shall be constructed as follows and as shown in table A-XXV. The UUF word shall use the COMMAND (110) preamble in bits P3 through P1 (W1 through W3). The character in the first position shall be the "pipe" or "vertical bar" "|" (1111100) in bits C1-7 through C1-1 (W4 through W10), which shall identify the "unique" function. The user or manufacturer specific unique index (UI) shall be a 14-bit (or two-character, 7-bit ASCII) code using bits UI14 through UI1 (W11 through W24). All unassigned UI codes shall be reserved and shall not be used until assigned for a specific use.

## MIL-STD-188-141A

## APPENDIX A

The UUF shall be used only among stations which are specifically addressed and included within the protocol, and shall be used only with stations specifically capable of participating in the UUF activity, and all other (nonparticipating) stations should be terminated. There are two exceptions for stations which are not capable of participating in the UUF and are required to be retained in the protocol until concluded. They shall be handled using either one of the two following procedures. First, the calling station shall direct all the addressed and included stations to stay linked for the duration of the UUF, to read and use anything that they are capable of during that time, and to resume acquisition and tracking of the ALE frame and protocol after the UUF ends. To accomplish this, and immediately before the COMMAND UUF, the sending station shall send the COMMAND STAY, which shall indicate the time period (T) for which the receiving stations shall wait for resumption of the frame and protocol. Second, the sending station shall use any standard COMMAND function to direct the nonparticipating stations to wait or return later, or do anything else which is appropriate and controllable through the standard orderwire functions.

If a COMMAND UUF is included within an ALE frame, it shall only be within the message section. The UUF activity itself should be conducted completely outside of the frame and should not interfere with the protocols. If the UUF activity itself must be conducted within the message section, will occupy time on the channel, and is incompatible with the ALE system, that activity shall be conducted immediately after the COMMAND UUF and it shall be for a limited amount of time (T). A COMMAND STAY shall precede the UUF instruction, as described herein, to indicate that time (T). The sending station shall resume the same previous redundant word phase when the frame and protocol resumes, to ensure synchronization. The STAY function preserves maintenance of the frame and link. It instructs the stations to wait, because the amount of time occupied by the UUF activity or its signaling may conflict with functions such as the wait-for-activity timer (Twa). This may interfere with the protocols or maintenance of the link. In any case, the users of the UUF shall be responsible for noninterference with other stations and users, and also for controlling their own stations and link management functions to avoid these conflicts.

The user unique function (UUF) shall be constructed as follows and as shown in table A-XXV. The UUF word shall use the COMMAND (110) preamble in bits P3 through P1 (W1 through W3). The character in the first position shall be the "pipe" or "vertical bar" (1111100) in bits C1-7 through C1-1 (W4 through W10), which shall identify the "unique" function. The user or manufacturer specific unique index (UI) shall be a 14-bit (or two-character, 7-bit ASCII) code using bits UI14 through UI1 (W11 through W24). All unassigned UI codes shall be reserved and shall not be used until assigned for a specific use.

## MIL-STD-188-141A

## APPENDIX A

TABLE A-XXV. User unique functions structure.

	User unique function bits		Word bits
COMMAND preamble	MSB	P3 = 1	MSB W1
		P2 = 1	W2
	LSB	P1 = 0	W3
First character "1" 1	MSB	C1-7 = 1	W4
		C1-6 = 1	W5
		C1-5 = 1	W6
		C1-4 = 1	W7
		C1-3 = 1	W8
		C1-2 = 0	W9
	LSB	C1-1 = 0	W10
First UI character	MSB	UI1-7	W11
		UI1-6	W12
		UI1-5	W13
		UI1-4	W14
		UI1-3	W15
		UI1-2	W16
Second UI character	LSB	UI1-1	W17
	MSB	UI2-7	W18
		UI2-6	W19
		UI2-5	W20
		UI2-4	W21
		UI2-3	W22
	LSB	UI2-2	W23
	UI2-1	W24	

## NOTES:

1. COMMAND user unique functions first character is " " (1111100) for "unique".
2. Unique index (UI) characters UI1 and UI2 from central registry and assignment.

## MIL-STD-188-141A

## APPENDIX A

## 90. LINK PROTECTION.

90.1 General. In many HF radio networks, it is necessary to prevent adversaries from surreptitiously entering the net or denying its use to legitimate members by means of deception. This shall be achieved by scrambling the ALE words used to establish links, thereby preventing the adversary from establishing links to legitimate members because he cannot communicate with them. Because this protection is applied to the link establishment function, link protection is a data link layer function in terms of International Standard 7498 (ISO 7498-1984), the Open Systems Interconnection (OSI) reference model. Figure A-34 shows a conceptual model of the MIL-STD-188-141A data link layer functions, showing the placement within the data link layer at which link protection shall be implemented.

90.2 Description. The data link layer without link protection consists of two sublayers: (a) a lower sublayer concerned with error correction and detection (FEC sublayer); and (b) an upper sublayer containing the ALE protocol (ALE sublayer). The FEC sublayer comprises redundancy/majority voting, interleaving, and Golay coding applied to 24-bit ALE words. The ALE sublayer specifies protocols for link establishment, data communication, and link quality analysis (LQA).

90.3 Synchronization. Synchronization functions are found in both sublayers: "pattern sync" depends on FEC functions such as unanimous votes and successful Golay decodes, along with scanning the received bit stream to match bit patterns sought by the ALE sublayer (e.g., "TO self address" words). "Word sync" is maintained in the ALE sublayer by checking received words in the context of the ALE protocol.

90.4 Location. The proper location for link protection is at the boundary between the FEC sublayer and the ALE sublayer as shown on figure A-34. At this point, the full power of the error correction techniques has been harnessed to reduce the error rate seen by the encryption algorithm. By inserting link protection between (beneath) the ALE protocol modules, unauthorized transmissions are excluded from interaction with the link establishment mechanism, either to establish unauthorized links or to interface with legitimate links.

90.5 Implementation. Radios or controllers designed to support link protection shall implement it as a module which may be removed or disabled and leave the system operational in an unprotected mode. The link protection function shall encrypt and decrypt entire 24-bit ALE words by performing a bit-by-bit exclusive-OR of data bits and key stream bits. Key stream bits shall be generated as follows:

- a. For those links that require protection, but do not insert classified information into the ALE protocol, secure sequence generators using the KGV-10 as defined in MIL-STD-188-148 shall be employed to generate the key stream.

## MIL-STD-188-141A

## APPENDIX A

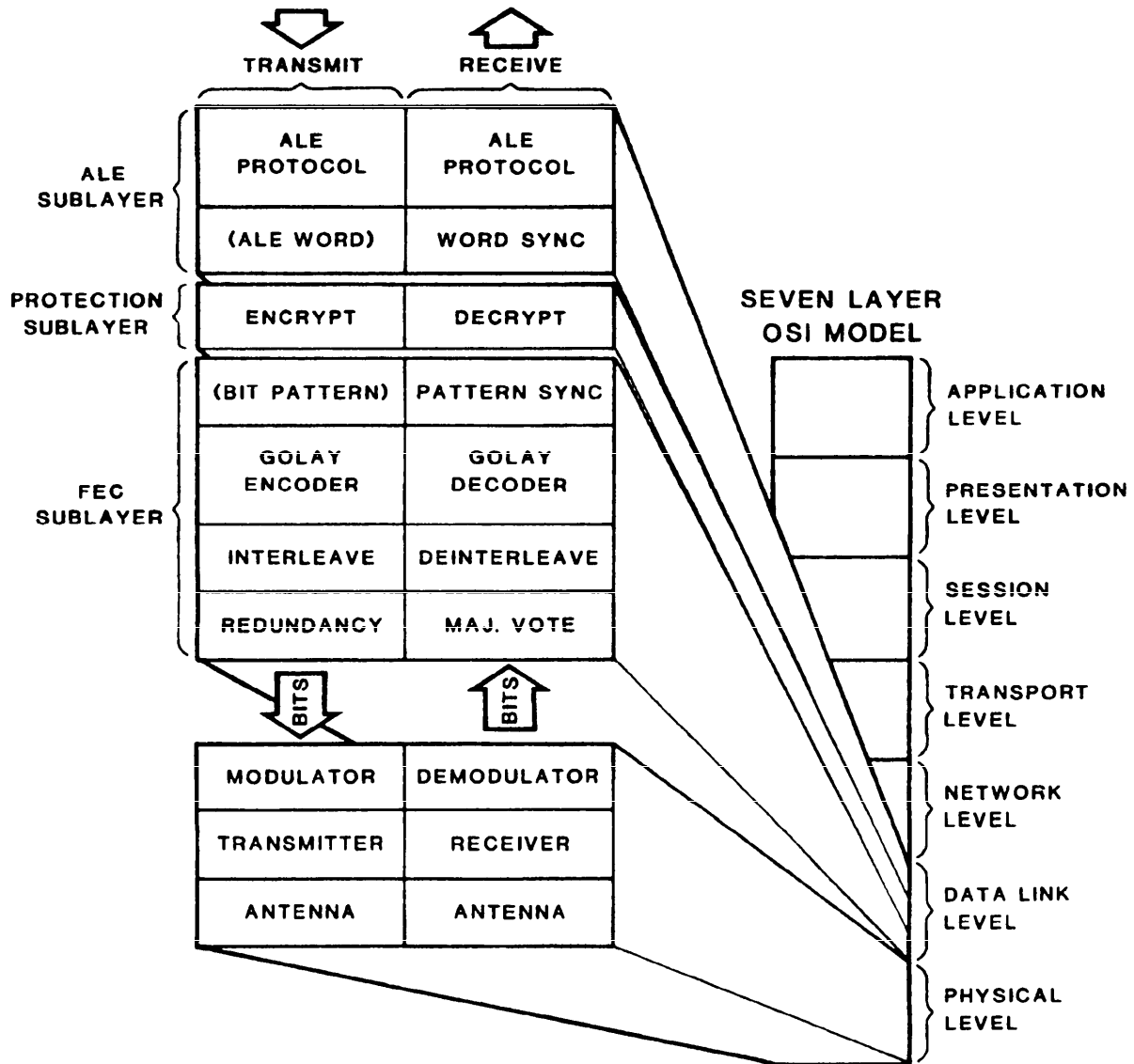
FIGURE A-34. Data link layer with link protection sublayer.



MIL-STD-188-141A

APPENDIX A

- b. Other links shall employ the NSA Commercial COMSEC Endorsement Program (CCEP) Type I module INDICTOR for key stream generation. This module may be used in either of two modes: (a) an unclassified mode with an unclassified key; or (b) a classified mode which requires a classified key. The latter mode shall be employed to protect highly-sensitive networks or classified orderwire traffic.

## MIL-STD-188-141A

## APPENDIX A

## ANNEX A. DEFINITIONS OF TIMING SYMBOLS

C	Number of channels in scan sequence
H	Handshake. Completed sequence of call, response, and acknowledgement
n	Integer
NA	Number of addresses
NAm	Number of addresses with "m" words
NAW	Number of original individual address words
NS	Number of slots in response period, total
s	Seconds
SN	Slot number identification
T	Time
Ta	Individual station (or net) whole address time
Ta1	Individual station (or net) address first word time
Ta max	Maximum individual station (or net) whole address time limit
Tar	Acknowledgement received event time
Tc	Call time, combination of whole address(es), which is usually repeated as a leading call T1c
Tc1	Combined different first words of group station address
Tcc	Calling cycle time
Tc max	Maximum call time limit
Td(5) & Td(2)	Basic dwell time on each channel during scan. Number is channels per second scanning rate.
Tdbm	Data block message time
Tdek	Decode time

## MIL-STD-188-141A

## APPENDIX A

Tdrrw	Detect rotating redundant word time
Tdrw	Detect redundant word time
Tds	Detect signaling (tones and timing) time
Tenk	Encode time
Ths	Handshake time, start to finish total (without tuning)
Tlc	Leading call time
Tld	Late detect word additional time
Tlww	Last word wait delay
Tm	Orderwire message section time
Tm max	Maximum orderwire message section time limit
Tp	Propagation time
Tps	Periodic sounding interval
Trc	Redundant call time
Trd	Receiver internal signal delay time
Trr	Response received event time
Trs	Redundant sound time
Trw	Redundant word time (392 ms)
Trwp	Redundant word phase delay (0 to Trw)
Ts	Scan period
Tsc	Scan calling time, same as Tss
Ts max	Maximum scan period
Ts min	Minimum scan period
Tsrc	Scanning redundant call time
Tsrs	Scanning redundant sound time
Tss	Scan sounding time, same as Tsc

## MIL-STD-188-141A

## APPENDIX A

Tsw	Slot width time
Tswf	Fixed slot width time
Tswt	Slot wait time delay after end of call, until slotted response starts
Tt	Tuneup time delay of antenna tuner or coupler
Tta	Turnaround time, receipt of end of signal to start of reply
Ttc	Transmitter command (to transmit) time
Ttd	Transmitter internal signal delay time
Ttk	Transmitter acknowledgement (that it is transmitting) time
Ttone	Tone (8 ms)
Tw	Word time (130.66... ms)
Twa	Wait for activity time
Twan	Wait for net acknowledgement time (for called stations).
Twan max	Maximum limit group call wait for reply time (for late arrival called stations)
Twce	Wait for calling cycle end (message or terminator sections)
Twr	Wait for reply time
Twrn	Wait for net/group reply time (for calling stations)
Twrt	Wait for reply and tune (scanning) time
Twt	Wait (listen first) time before tune or transmit
Tx	Termination section time
Tx max	Maximum termination section time limit
WRT	Wait for reply timer (load with Twr)
WRTT	Wait for response and tune timer (load with Twrn or Twrt)

## MIL-STD-188-141A

## APPENDIX A

## ANNEX B. TIMING

Note: Refer to annex A and table A-XIV.

Basic system timing

- o Tone (symbol) rate = 125 symbols per second
- o Tone period:  
 $T_{\text{tone}} = \underline{8 \text{ ms}}$  per symbol
- o On-air bit rate = 375 bits per second
- o On-air individual word period (never sent alone):  
 $T_w = 16.33... \text{ symbols} \times T_{\text{tone}} = \underline{130.66... \text{ ms}}$
- o On-air (triple) redundant word period:  
 $T_{\text{rw}} = 3T_w = 49 \text{ tone} = \underline{392 \text{ ms}}$
- o On-air individual (or net) address time, for  $m = 1$  to 5 words:  
 $T_a = m \times T_{\text{rw}} = \underline{392 \text{ ms}}$  to  $\underline{1960 \text{ ms}}$
- o Propagation time, range divided by speed of wave, for MF/HF signals, local to global:  
 $T_p = \underline{0}$  to  $\underline{70 \text{ ms}}$

## MIL-STD-188-141A

## APPENDIX A

System timing limits

- o Maximum individual station (or net) address time limit, based on 15-character (or 5-word) maximum:  

$$\underline{T_a \max} = 5 \text{ Trw} = \underline{1,960 \text{ ms}}$$
- o Individual (or net) address first word, used in scan call Tsc:  

$$\underline{T_{a1}} = \underline{\text{Trw}} = \underline{392 \text{ ms}}$$
- o Maximum group combined addresses different first words time limit, maximum 5 first words, in scan call Tsc:  

$$\begin{aligned} T_{c1} &= \Sigma T_{a1} \text{ (different)} \\ \underline{T_{c1 \max}} &= 5 T_{a1} = 5 \text{ Trw} = \underline{1960 \text{ ms}} \end{aligned}$$
- o Maximum call time limit, based on 12-word maximum, whole addresses in Tlc:  

$$\underline{T_c \max} = 12 \text{ Trw} = \underline{4,704 \text{ ms}}$$
- o Maximum scan cycle period limit, based on 2 channels per second and 100 channels:  

$$\underline{T_s \max} = \underline{50 \text{ s}}$$
- o Maximum message (orderwire) section time limit, unless adjusted by COMMAND:  

$$\begin{aligned} \underline{T_m \max \text{ AMD and other COMMANDS}} &= \underline{11.76 \text{ s}} \\ \underline{T_m \max \text{ DTM}} &= \underline{2.29 \text{ min}} \\ \underline{T_m \max \text{ DBM}} &= \underline{23.36 \text{ min}} \end{aligned}$$
- o Maximum termination section time limit, same as Ta max:  

$$\underline{T_x \max} = T_a \max = \underline{1,960 \text{ ms}}$$

Individual calling

- o Initial and minimum dwell time on each channel by receiving station during normal receive scanning; inverse of scanning rate; not including extended pause to read words:

## MIL-STD-188-141A

## APPENDIX A

$$\begin{aligned} T_{d(5)\min} &= 200 \text{ ms at 5 channels per second basic scan rate, or} \\ T_{d(2)\min} &= 500 \text{ ms at 2 channels per second minimum scan rate} \\ T_{d(10)\min} &= 100 \text{ ms at 10 channels per second (D0)} \end{aligned}$$

- o Scan period for receiving station to scan all scanned channels during normal receive scanning, where "C" is the number of scanned channels; not including extended pause to read words:

$$T_s \min = C \times T_d \min$$

For example,

$$\begin{aligned} T_s \min &= 0 \text{ for single-channel, nonscan case, or} \\ &= 2 \text{ seconds for typical } C = 10 \text{ at 5 chps, or} \\ &= 5 \text{ seconds for } C = 10 \text{ at 2 chps minimum rate} \\ &= 1 \text{ second for } C = 10 \text{ at 10 chps (D0)} \end{aligned}$$

- o For scan call Tsc computations, use Ts based on probable maximum pause on each channel (Td, to read words) of Tdrw = 2 Trw (Td may be adjusted by net managers for best system performance):

$$T_s = C \times T_d = C \times T_{drw}$$

For example,

$$T_s = 7,840 \text{ ms for } C = 10 \text{ channels and } T_d = T_{drw}$$

- o Call time, the called whole address (or combination of called whole addresses, if a group call), which may be repeated in the leading call Tlc; maximum limit 12 one-word addresses:

$$\begin{aligned} T_c &= T_a \text{ (called) for single-station (or net) calls, or} \\ &= T_a \text{ (first) + } T_a \text{ (second) + } \dots + T_a \text{ (last) if} \\ &\quad \text{group call} \end{aligned}$$

- o First-word call time, the called address first word (or combination of addresses first words, if a group call), which is repeated in the scanning call Tsc; maximum limit 5 different first words:

$$\begin{aligned} T_{c1} &= T_{a1} \text{ (called) for single-station (or net) calls, or} \\ &= T_{a1} \text{ (first) + } T_{a1} \text{ (second different) + } \dots + T_{a1} \text{ (last} \\ &\quad \text{different) if group call} \end{aligned}$$

- o Leading call time, composed of two complete repetitions of Tc, which contains the whole address(es):

$$\begin{aligned} T_{lc} &= 2T_c = 2T_a \text{ (called) for single-station (or net) calls, or} \\ &= 2(T_a \text{ (first) + } T_a \text{ (second) + } \dots + T_a \text{ (last)}), \\ &\quad \text{if group call} \end{aligned}$$



## MIL-STD-188-141A

## APPENDIX A

- o Scanning call time, consisting of repetitions of only the first word(s)  $T_{a1}$  of the called address (or combination of addresses, if a group call), for calling station to "capture" scanning receivers during normal scanning calling. Therefore,  $T_{sc}$  is a multiple  $T_{c1}$  (group of  $T_{a1}$ 's if a group call) of words, which is  $\geq$  the receiver's scan period  $T_s$ , where  $n$  is any integer such that  $T_{sc} \geq T_s$ :

$$\underline{T_{sc} = n \times T_{c1} \geq T_s = C \times T_d}$$

For example,

$$T_{sc} = 0 \text{ for single-channel individual call case, or} \\ \geq 20 \text{ Trw} = 7840 \text{ ms if } C = 10 \text{ and } T_d = T_{drw}$$

- o Calling cycle time for calling station to both "capture" scanning receivers and ensure reading the called station address(es), consisting of scan calling time ( $T_{sc}$ ) plus leading call time ( $T_{lc}$ ), respectively:

$$\underline{T_{cc} = T_{sc} + T_{lc} \geq T_s + T_{lc}}$$

For example,

$$T_{cc} = T_{lc} = 2T_a \text{ (called)} = 784 \text{ ms for single-channel one-word} \\ \text{address individual (or net) call case (} T_s = 0 \text{), or} \\ = T_{sc} + T_{lc} = (20 + 2) \text{ Trw} = 8624 \text{ ms if } C = 10 \\ \text{and } T_d = T_{drw}$$

- o Single-channel redundant call time, consisting of individual (or net) leading call  $T_{lc}$  (with  $T_0$ ) plus terminator  $T_a$  (with THIS IS or THIS WAS), not including any message section time:

$$\underline{T_{rc} = T_{lc} + T_x = 2T_c + T_x = 2T_a \text{ (called)} + T_a \text{ (caller)} \\ = 3 \text{ Trw min} = 1176 \text{ ms minimum, for individual station} \\ \text{(or net) call using one-word addresses.} \\ = 15 \text{ Trw min} = 5880 \text{ ms max for 5-word addresses}$$

- o Scanning redundant call time, consisting of scanning call time  $T_{sc}$ , and redundant call time  $T_{rc}$ , respectively:

$$\underline{T_{src} = T_{sc} + T_{rc}}$$

For example, using one-word addresses:

$$T_{src} = (20 + 3) \text{ Trw} = 9016 \text{ ms if } C = 10 \text{ and } T_d = T_{drw}$$

## MIL-STD-188-141A

## APPENDIX A

- o Last word wait additional fixed delay at replying or receiving station, after (possibly early) detected end of received call and before start of reply, to avoid on-air overlap, loss of additional termination (caller address) words, and to allow margin for transmitter turnaround for reception:

$$\underline{T_{lww}} = T_{rw} = \underline{392 \text{ ms}}$$

- o Late word detection additional fixed delay at calling station, to increase wait for reply time in case of possibly late detection at called station:

$$\underline{T_{ld}} = T_w = \underline{130.66... \text{ ms}}$$

- o Redundant word phase delay. To synchronize a transmission to any recently preceding transmissions, and used on all but first transmission of a handshake or exchange until terminated period:

$$\underline{T_{rwp}} = \underline{0 \text{ to } 392 \text{ ms}} \leq T_{rw}$$

- o Turnaround time at replying station, measured at rf port(s); from end of received signal to start of transmitted reply, not including delays such as  $T_{lww}$  or  $T_{ld}$  and including receiver and transmitter internal signal delays,  $T_{rd}$  and  $T_{td}$ ; decode and encode times,  $T_{dek}$  and  $T_{enk}$ ; and transmitter command and acknowledgement delays,  $T_{tc}$  and  $T_{tk}$ :

$$\underline{T_{ta}} = \underline{T_{rd} + T_{dek} + T_{enk} + T_{tc} + T_{tk} + T_{td}}$$

For example approximations,

$$\begin{aligned} \underline{T_{ta}} &= 0 \text{ for new, fast equipment, or} \\ &= 2 T_w = 261.33... \text{ms estimated allowance for old} \\ &\quad \text{slower equipment} \end{aligned}$$

- o Wait for calling cycle end time at receiving station, is delineated by receipt of start of message, terminator, or quick-ID section:

$$T_{wce} = 2 \times T_s \text{ (of own station) as default value}$$

## MIL-STD-188-141A

## APPENDIX A

- o Wait for reply time at calling station, from end of transmitter signal to start of received reply detection periods ( $T_{ds}$ ,  $T_{drw}$ , and  $T_{drrw}$ , below); including propagation,  $T_p$ ; last word wait,  $T_{lww}$ ; late word detection,  $T_{ld}$ ; turnaround,  $T_{ta}$ ; redundant word phase delay (if not first transmission in handshake or exchange),  $T_{rwp}$ ; and receiver and transmitter internal signal delays,  $T_{rd}$  and  $T_{td}$ ; in a single-channel case without tune times, or multi-channel scanning case after first tune and transmission:

$$\underline{T_{wr}} = \underline{T_{td} + T_p + T_{lww} + T_{ta} + T_{rwp} \text{ (if not first)} + T_{ld} + T_p + T_{rd}}$$

For example approximations,

$$\begin{aligned} T_{wr} &= 5 T_w = 653.33... \text{ ms for fast equipment, or} \\ &= 7 T_w = 914.66... \text{ ms for slower equipment, maximum} \\ &= 8 T_w = 1045.33... \text{ ms for fast equipment if not first} \\ &= 10 T_w = 1306.66... \text{ ms for slower equipment if not first} \end{aligned}$$

- o Tune time delay, after issuance of tuneup command and before ready to transmit the reply signal:

$$\underline{T_t} = \underline{\text{maximum tuneup delay for slowest tuner in system (or net/group being called)}}$$

For examples, typical allowance ranges are

$$\begin{aligned} T_t &\leq T_w = 130.66... \text{ ms for fast (solid state) tuners or} \\ &\leq 8 T_w = 1,045.33... \text{ ms for fast relay tuners, or} \\ &\leq 20 \text{ seconds for old electromechanical (servo drive) tuners,} \\ &\text{or as required by available equipment} \end{aligned}$$

NOTE: If tune time(s) of called station(s) is unknown, first try default value shall be 8  $T_w$  and second try default value shall be at least 20 seconds.

- o Wait for response and tune time, same as wait for reply  $T_{wr}$ , plus tune time  $T_t$  in scanning cases, and relevant only to first transmission on a channel (which requires tuning time):

$$\underline{T_{wrt}} = \underline{T_{wr} + T_t}$$

For examples, typical allowance ranges are

$$\begin{aligned} T_{wrt} &= 6 T_w = 784 \text{ ms for fast tuners, or} \\ &15 T_w = 1,960 \text{ ms for slower tuners, or} \\ &\text{adjusted as required by available equipment} \end{aligned}$$

## MIL-STD-188-141A

## APPENDIX A

NOTE: If tune time(s) of called station(s) is unknown, first try default value shall be 15 Tw and second try default value shall be at least 20 seconds.

- o Detect signaling tones and timing (of call or reply) detection period; after arrival on channel during normal receive scanning, or after end of wait for reply time Twr or Twrt during normal calling, and before automatic return to normal receive scanning; used to identify channel vacancy or occupancy with standard ALE signaling.

$$\underline{Tds} \quad Td(5) = \underline{200 \text{ ms}}$$

- o Detect redundant words detection period, starting same as Tds, and used to continue beyond Tds if tones and timing are detected, before automatic return to normal receive scanning; used for acceptance of basic single-word (and address first word) addressing and to read calls:

$$\underline{Tdrw} = Trw + \text{spare } Trw = 6 Trw = 784 \dots \text{ms}$$

- o Detect rotating redundant words detection period, starting same time as Tds, and used to continue beyond Tdrw if redundant words are detected, before automatic return to normal receive scanning; used for acceptance of extended (multiword) addressing and/or group calls:

$$\underline{Tdrrw} = 2 Trw + \text{spare } Trw = 9 Trw = \underline{1,176 \text{ ms}}$$

Sounding

- o Single-channel redundant sound time, like leading call Tlc, but with only the "THIS IS or THIS WAS" terminator, using twice the whole address:

$$\underline{Trs} = 2Ta \text{ (caller)}$$

For examples

$$Trs = 2Trw = 784 \text{ ms minimum, individual single-word address sound on a single channel}$$

- o Scanning sound time. Like Tsc, but using whole address only (not just first word of address):

$$\underline{Tss} = n \times Ta \text{ (caller)} \geq Ts$$

## MIL-STD-188-141A

## APPENDIX A

- o Scanning redundant sound time, like calling cycle time,  $T_{cc}$ , consisting of redundant sound time  $T_{rs}$ , with addition of scanning sounding time  $T_{ss}$  (which is identical to  $T_{sc}$ ):

$$T_{srs} = T_{ss} + T_{rs} = (2 + n)T_a(\text{caller}) \geq T_s + T_{rs}$$

For examples,

$$T_{srs} = (20 + 2) T_{rw} = 8624 \text{ ms if } C \text{ and } T_d = T_{drw}$$

Star calling

- o Minimum uniform slot width for automatic slotted responses in normal single-word address star net and group calling protocols (but may be modified by COMMAND):

$$\begin{aligned} T_{sw}(\text{min}) &= 14 T_w = 1,829.33... \text{ ms for standard replies, or} \\ &= 17 T_w = 2221.33... \text{ ms for LQA replies, or} \\ &= 9 T_w = 1,176 \text{ ms for only fixed "tight slot"} \\ &\quad \text{replies, or} \\ &= n \times T_w \text{ by } \underline{\text{COMMAND}} \end{aligned}$$

NOTE: Replies above are for first transmissions; if not,  $T_{sw} \text{ min} = 17, 20, \text{ and } 12 T_w$  respectively, (due to redundant word-phase delay).

- o Slot wait time before start of slotted response and after detection of end of calling signal, where "SN" is the assigned (or derived) slot number, for group or preset net calling:

$$\begin{aligned} T_{swt}(\text{SN}) &= T_{sw} \times \text{SN for uniform slot widths} \\ &\quad \text{(by } \underline{\text{COMMAND}} \text{ or net manager), or} \\ T_{swt}(\text{SN}) &= T_{sw} \times \text{SN ... or} \\ T_{swt}(\text{SN}) &= \text{SN} [5 T_w + 2T_a(\text{caller}) + (\text{optional LQA}) T_{rw} + \\ &\quad (\text{optional message}) T_m] + T_a(\text{caller}) + [(\text{sum of all previous} \\ &\quad \text{called addresses}) \\ &\quad \sum_{m=1}^{\text{SN}-1} T_a(m)(\text{called})] \\ &\quad \text{as the general case.} \end{aligned}$$

For example,

$$T_{swt}(5) = 14 T_w \times 5 = 70 T_w = 9,146.66... \text{ ms delay for start of normal 5th slot response, first time, no LQA, single word address.}$$

## MIL-STD-188-141A

## APPENDIX A

- o Wait for net reply buffer time at calling station, after end of star net or group call, until responses should be received and an acknowledgement can be started, where "NS" is the total number of slots:

$$\begin{aligned} T_{wrn}(\text{calling}) &= (T_{sw} \times NS) \text{ for uniform slots or generally,} \\ &= T_{sw}(NS) \end{aligned}$$

- o Wait for net acknowledge buffer time at called stations, to receive acknowledgement after end of star net or group call:

$$\begin{aligned} T_{wan}(\text{called}) &= (T_{sw} \times NS) + T_{drw} \\ &= T_{wrn}(\text{calling}) + 2 T_{rw} \end{aligned}$$

- o Turnaround plus tune time totals for slotted responses have the following limits (not including  $T_{lww}$ ):

$$\begin{aligned} T_{ta} + T_t & \quad 1500 \text{ ms for standard slots, except} \\ & \quad 2100 \text{ ms for slot 1 only, or} \\ & \quad 360 \text{ ms for slot 0 emergency or interrupt} \end{aligned}$$

- o Maximum star group wait for acknowledgement time at called stations:

$$T_{wan \text{ max}} = 107 T_w + 27 T_a (\text{caller}) + 13 T_{rw} (\text{optional LQA}) + 13 T_m (\text{optional message})$$

- o Default maximum star group wait for acknowledgement time for late arrival, called stations, not knowing the size of the group. There are two default maximum waiting values, before automatically returning to normal receive scanning, if no message and caller uses single-word address:

$$\begin{aligned} T_{wan \text{ max}} &= 188 T_w = 24,565.33...ms \text{ if standard, or} \\ & \quad 277 T_w = 29,661.33...ms \text{ if LQA requested} \end{aligned}$$

Programmable timing parameters

Unless otherwise programmed by the network manager, the following typical timing values are recommended:

- o Dwell time per channel, basic receive scanning:

$$T_d(5) = 200 \text{ ms for 5 chps basic scan rate}$$

## MIL-STD-188-141A

## APPENDIX A

- o Dwell time per channel, minimum receive scanning:

$$\underline{T_d(2)} = \underline{500 \text{ ms}} \text{ for 2 chps minimum scan rate}$$

- o Dwell time for calculations of  $T_s$  (and  $T_{sc}$ ), based on probable maximum typical pause (may be adjusted by net manager for best system performance):

$$T_d = T_{drw} = 2T_{rw} = 784 \text{ ms}$$

- o Wait (listen first) time before tune or transmit:

$$\begin{aligned} \underline{T_{wt}} &= 2 \text{ seconds for voice or general purpose channels or,} \\ &= \underline{T_{drw}} = 784 \text{ ms for ALE and data only channels} \end{aligned}$$

- o Tune time allowance for wait for response time is normally set for slowest known tuner in associated network; except if unknown parameter (such as in blind internet calls to "strangers"):

$$\begin{aligned} \underline{T_t} &= 8T_w = \underline{1045.33... \text{ ms}} \text{ for first call, and} \\ &= \underline{20 \text{ seconds}} \text{ for next try} \end{aligned}$$

- o Automatic periodic sounding intervals (when channels are clear):

$$\underline{T_{ps}} = \underline{30 \text{ minutes}} \text{ when enabled (disableable).}$$

- o Wait for activity time after linking or use, before automatic return to normal receive scanning:

$$\underline{T_{wa}} = \underline{30 \text{ minutes}} \text{ when enabled (disableable).}$$

## MIL-STD-188-141A

## APPENDIX A

## ANNEX C. SUMMARY OF ALE SIGNAL PARAMETERS

ALE occupied bandwidth	500-2750 Hz
Quantity of tones	8 (one per symbol period)
Tone frequencies	750; 1000; 1250; 1500; 1750; 2000; 2250; 2500 Hz
Tone values	000 001 011 010 110 111 101 100
Symbol changes	Tone transitions are phase continuous
Symbol structure	3 bits of binary coded data
Symbol rate; period	125 symbols per second (sps); 8 ms
Coded data rate	375 bits per second (bps) transmitted
Forward error correction (FEC)	Golay (24, 12, 3) half-rate coding (4 modes of correct/detect; 3/4, 2/5, 1/6, or 0/7)
Auxiliary coding (DTM, AMD, basic ALE)	Redundant x 3, with 2/3 majority vote (with 49 transmitted bits)
Auxiliary coding (DBM)	Interleaving depth (ID) = 49 to 21903 = (n x 49)
Uncoded data rate (DTM, AMD, basic ALE)	61.22 bps
Uncoded data rate (DBM)	187.5 bps
Uncoded data bits per basic ALE word (DTM, AMD)	24 (21 (3 characters) plus 3 preamble), per word
Uncoded data bits per message (DTM)	From 0 to 7371 bits per block
Uncoded data bits per message (DBM)	From 0 to 262820 bits per block, plus 16 bits CRC
Throughput maximum data rate (DTM, AMD, basic ALE)	53.57 bps data bits
Throughput maximum data rate (DBM)	187.5 bps data bits
Characters per word (AMD or basic ALE)	0 to 3 expanded 64 or full ASCII
Characters per message (DTM)	0 to 1053 full ASCII characters per block



## MIL-STD-188-141A

## APPENDIX A

Characters per message (DBM)	0 to 37545 full ASCII characters per block
Character rate (DTM, AMD, basic ALE)	7.653 cps
Character rate (DBM)	26.79 cps
Equivalent throughput maximum word rate (DTM, AMD)	76.53 words per minute (wpm) (5 characters plus space per word)
Equivalent throughput maximum word rate (DBM)	267.9 wpm (5 characters + space per word)
Unit period (DTM, AMD, or ALE word)	130.66... ms per word (Tw) or 392 ms per triple redundant word (Trw)
Message period (DTM)	0 to 2.29 minutes per block
Message period (DBM)	128 ms to 16.32 s per block
Minimum sound time	784 ms (2 Trw)
Minimum call time	1176 ms (3 Trw)
Minimum handshake time	3528 ms (9 Trw) three-way linking
Preambles (word types)	8 (3 bits)
Character sets	ASCII (basic 38, expanded 64, full 128), or random bits
Link quality analysis (LQA)	ALE (BER, SINAD, and MP)

MIL-STD-188-141A

CONCLUDING MATERIAL

Custodians:  
Army--SC  
Navy--EC  
Air Force--90

Preparing activity:  
Army--SC

Review activities:  
Army--CR  
Navy--MC  
DoD--DC, NS, JT

(Project SLHC-1411)

**INSTRUCTIONS:** In a continuing effort to make our standardization documents better, the DoD provides this form for use in submitting comments and suggestions for improvements. All users of military standardization documents are invited to provide suggestions. This form may be detached, folded along the lines indicated, taped along the loose edge (*DO NOT STAPLE*), and mailed. In block 5, be as specific as possible about particular problem areas such as wording which required interpretation, was too rigid, restrictive, loose, ambiguous, or was incompatible, and give proposed wording changes which would alleviate the problems. Enter in block 6 any remarks not related to a specific paragraph of the document. If block 7 is filled out, an acknowledgement will be mailed to you within 30 days to let you know that your comments were received and are being considered.

**NOTE:** This form may not be used to request copies of documents, nor to request waivers, deviations, or clarification of specification requirements on current contracts. Comments submitted on this form do not constitute or imply authorization to waive any portion of the referenced document(s) or to amend contractual requirements.

(Fold along this line)

(Fold along this line)

DEPARTMENT OF THE ARMY



NO POSTAGE  
NECESSARY  
IF MAILED  
IN THE  
UNITED STATES

OFFICIAL BUSINESS  
PENALTY FOR PRIVATE USE \$300

**BUSINESS REPLY MAIL**  
FIRST CLASS PERMIT NO. 12062 WASHINGTON D. C.

POSTAGE WILL BE PAID BY THE DEPARTMENT OF THE ARMY

COMMANDER  
U.S. ARMY INFORMATION SYSTEMS  
ENGINEERING COMMAND  
ATTN: ABB-SET-T  
FORT HUACHUCA, AZ 85613-5300

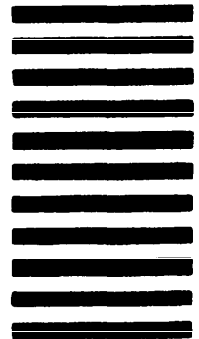

## STANDARDIZATION DOCUMENT IMPROVEMENT PROPOSAL

*(See Instructions - Reverse Side)*

1. DOCUMENT NUMBER <b>MIL-STD-188-141A</b>		2. DOCUMENT TITLE <b>INTEROPERABILITY AND PERFORMANCE STANDARDS FOR MEDIUM AND HIGH FREQUENCY RADIO EQUIPMENT</b>	
3a. NAME OF SUBMITTING ORGANIZATION		4. TYPE OF ORGANIZATION <i>(Mark one)</i>	
b. ADDRESS <i>(Street, City, State, ZIP Code)</i>		<input type="checkbox"/> VENDOR <input type="checkbox"/> USER <input type="checkbox"/> MANUFACTURER <input type="checkbox"/> OTHER <i>(Specify)</i> : _____	
5. PROBLEM AREAS			
a. Paragraph Number and Wording:			
b. Recommended Wording:			
c. Reason/Rationale for Recommendation:			
6. REMARKS			
7a. NAME OF SUBMITTER <i>(Last, First, MI) - Optional</i>		b. WORK TELEPHONE NUMBER <i>(Include Area Code) - Optional</i>	
c. MAILING ADDRESS <i>(Street, City, State, ZIP Code) - Optional</i>		8. DATE OF SUBMISSION <i>(YYMMDD)</i>	

(TO DETACH THIS FORM, CUT ALONG THIS LINE.)