

INCH-POUND

MIL-W-25038F
 16 September 1993
 SUPERSEDING
 MIL-W-25038E
 12 December 1980

MILITARY SPECIFICATION

WIRE, ELECTRICAL, HIGH TEMPERATURE, FIRE RESISTANT,
 AND FLIGHT CRITICAL, GENERAL SPECIFICATION FOR

This specification is approved for use by all Departments
 and Agencies of the Department of Defense.

1. SCOPE

1.1 Scope. This specification covers insulated single wire for electrical use in flight critical circuits and under short-time emergency conditions involving exposure to flames with temperatures up to 2,000°F (1,093°C) (see 6.1).

1.2 Part or Identifying Number (PIN). The PIN consists of the letter "M", which indicates a military specification item; the basic number of the specification sheet; and a coded number as shown in the following example:

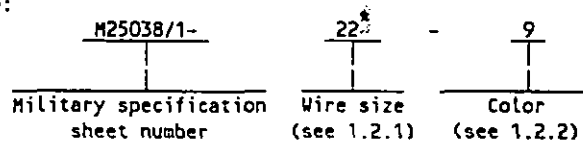

* NOTE: For MIL-W-25038/3 the heavier wall construction has an "H" designator added to the PIN.

1.2.1 Wire size. The wire size is identified by a number indicating the conductor wire size (AWG).

1.2.2 Color. The insulation color is identified by a series of numbers. The first number is the color of the insulation, the second number represents the color of the first stripe or band, the third number, the color of the second stripe or band, etc. The colors and their corresponding number are as follows:

COLOR CODE CHART

Number designator	Color	Number designator	Color
0 - - - -	Black	5 - - - -	Green
1 - - - -	Brown	6 - - - -	Blue
2 - - - -	Red	7 - - - -	Violet (purple)
3 - - - -	Orange	8 - - - -	Gray (slate)
4 - - - -	Yellow	9 - - - -	White

NOTE: This chart is not intended to signify a color sequence, but only a number color identification.

2. APPLICABLE DOCUMENTS

2.1 Government documents.

2.1.1 Specifications, standards, and handbooks. The following specifications, standards, and handbooks form a part of this document to the extent specified herein. Unless otherwise specified, the issues of these documents are those listed in the issue of the Department of Defense Index of Specifications and Standards (DODISS) and supplement thereto, cited in the solicitation (see 6.2).

Beneficial comments (recommendations, additions, deletions) and any pertinent data which may be of use in improving this document should be addressed to: Electronic Support Division, 645 LOG/ES Gentile AF Station, 1060 Hamilton Street, Dayton, OH 45444-5400 by using the Standardization Document Improvement Proposal (DD Form 1426) appearing at the end of this document or by letter.

AMSC N/A

DISTRIBUTION STATEMENT A. Approved for public release; distribution is unlimited.

FSC 6145

MIL-W-25038F

SPECIFICATIONS

MILITARY

- MIL-H-5606 - Hydraulic Fluid, Petroleum Base: Aircraft, Missile, and Ordnance.
- MIL-T-5624 - Turbine Fuel, Aviation, Grades JP-4 and JP-5.
- MIL-L-6082 - Lubricating Oil; Aircraft Reciprocating Engine (Piston).
- MIL-L-7808 - Lubricating Oil; Aircraft Turbine Engine, Synthetic Base.
- MIL-C-12000 - Cable, Cord, and Wire, Electric; Packaging of.
- MIL-D-12468 - Decontaminating Agent, Std.
- MIL-L-23699 - Lubricating Oil, Aircraft Turbine Engine, Synthetic Base.
- MIL-W-25038/1 - Wire, Electrical, Flight Critical, High Temperature and Fire Resistant, Normal Weight.
- MIL-W-25038/3 - Wire, Electrical, Flight Critical, High Temperature and Fire Resistant, Light Weight.
- MIL-D-50030 - Decontaminating Agent, Ds2.
- MIL-A-87244 - Avionics/Electronic Integrity Program Requirements.

STANDARDS

FEDERAL

- FED-STD-228 - Cable and Wire, Insulated; Methods of Testing.

MILITARY

- MIL-STD-104 - Limits for Electrical Insulation Color.
- MIL-STD-105 - Sampling Procedures and Tables for Inspection by Attributes.
- MIL-STD-109 - Quality Assurance Terms and Definitions.
- MIL-STD-790 - Reliability Assurance Program for Electronic Parts Specification.
- MIL-STD-45662 - Calibration Systems Requirements.

(Unless otherwise indicated, copies of federal and military specifications, standards, and handbooks are available from the Standardization Documents Order Desk, Building 4D, 700 Robbins Avenue, Philadelphia, PA 19111-5094.)

2.1.2 Other Government documents, drawings, and publications. The following other Government documents, drawings, and publications form a part of this document to the extent specified herein. Unless otherwise specified, the issues are those cited in the solicitation.

DEFENSE LOGISTICS AGENCY

- H4/H8 - Catalog of Commercial and Government Entities (CAGE).

(Application for copies should be addressed to the Superintendent of Documents, Government Printing Office, Washington, DC 20402.)

2.2 Non-Government publications. The following documents form a part of this document to the extent specified herein. Unless otherwise specified, the issues of the documents which are DoD adopted are those listed the issue of the DODISS cited in the solicitation. Unless otherwise specified, the issues of documents not listed in the DODISS are the issues of the document cited in the solicitation (see 6.2).

AMERICAN SOCIETY FOR TESTING AND MATERIALS

- ASTM B263 - Determination of Cross-sectional Area of Stranded Conductors
- ASTM B355 - Nickel-coated Soft or Annealed Copper Wire.
- ASTM B624 - High Strength, High Conductivity, Copper-Alloy Wire for Electronic Application.
- ASTM D910 - Gasolines, Aviation

(Application for copies should be addressed to the American Society for Testing and Materials, 1916 Race Street, Philadelphia, PA 19103-1137.)

MIL-W-25038F

ELECTRONIC INDUSTRIES ASSOCIATION (EIA)

EIA-557 - EIA Standard Implementation of Statistical Process Control (SPC) in Manufacturing Process.

(Application for copies should be addressed to the Electronic Industry Association, Engineering Department, 2001 Eye Street, N.W., Washington, DC 20006.)

NATIONAL ELECTRICAL MANUFACTURERS ASSOCIATION (NEMA)

NEMA WC 56 - 3.0 kHz Insulation Continuity Proof Testing for Hook-up Wire

(Applications for copies should be addressed to National Electrical Manufacturers Association, Engineering Department, 2101 L Street, N.W., Washington, DC 20037)

(Non-Government standards and other publications are normally available from the organizations that prepare or distribute the documents. These documents also may be available in or through libraries or other informational services.)

2.3 Order of precedence. In the event of a conflict between the text of this document and the references cited herein (except for related associated detail specifications, specification sheets or MS standards), the text of this document takes precedence. Nothing in this document, however, supersedes applicable laws and regulations unless a specific exemption has been obtained.

3. REQUIREMENTS

3.1 Specification sheets. The individual item requirements shall be as specified herein and in accordance with the applicable specification sheets. In the event of any conflict between requirements of this specification and the specification sheet, the latter shall govern.

3.2 Qualification. Connectors furnished under this specification shall be products which are authorized by the qualifying activity for listing on the applicable qualified products list at the time of award of contract (see 4.3 and 6.3).

3.2.1 Quality.

3.2.1.1 Statistical Process Control (SPC). The contractor shall implement and use statistical process control techniques in the manufacturing process for parts covered by this specification. The SPC program shall be developed and maintained in accordance with EIA-557. The SPC program shall be documented and maintained as part of the overall reliability assurance program as specified in MIL-STD-790. The implementation of statistical process control shall be 12 months from the date of the specification.

3.3 Materials.

3.3.1 Conductor material. Strands used in the manufacture of conductors shall be in accordance with ASTM B355, Class 27 and ASTM B624 coated with 27% nickel by weight as specified (see 3.1).

3.3.2 Insulating materials. The use of reclaimed or recycled material is not prohibited, however when used, the recycled materials shall not have been degraded, shall be free from contaminants, and shall be identical to virgin materials in performance. Insulating materials shall be in accordance with the applicable specification sheet and shall be capable of meeting all requirements specified herein.

3.3.2.1 Primary insulation. The primary insulation shall consist of a concentric layer of glass fibers, ceramics, or layers of glass tape and tetrafluoroethylene tape, or a combination of materials capable of withstanding the specified temperatures (see 4.6.4). Where fibrous primary insulation is used, the material shall be thoroughly impregnated with a silicone resin or other suitable compound so applied that it will not enter the strands of the conductor and affect good electrical contact. Asbestos shall not be used.

3.3.2.2 Outer layer. The outer layer of the construction shall consist of a closely woven braid of glass fiber impregnated with polytetrafluoroethylene (PTFE) or of extruded polytetrafluoroethylene, or tape wrapped and cured PTFE.

MIL-W-25038F

3.4 Design and construction. The wire shall be of the design, construction, and physical dimensions specified (see 3.1).

3.4.1 Conductors.3.4.1.1 Stranding.

3.4.1.1.1 Concentric lay. Wire sizes 22 through 12 shall be constructed with concentric-lay conductors and as specified in table I. Concentric lay shall be interpreted to be a central core surrounded by one or more layers of helically wound strands. It is optional for the direction of lay for successive layers to be alternately reversed (true concentric lay) or to be in the same direction (unidirectional lay). If the direction of lay for the successive layers is the same, the pitch or length of lay shall increase with each successive layer. The direction of lay of individual strands in the outer layer of the concentrically stranded conductors of finished wire sizes 22 through 12 shall be left hand. The length of lay in the outer layer shall be not less than 8 nor more than 16 times the maximum conductor diameter specified in table I.

TABLE I. Wire construction details.

Wire size	Nominal conductor area (circular mils)	Minimum CMA of conductor (circular mils)	K Value	Stranding Number of strands X (AVG)	Allowable number of missing strands	Nominal diameter of individual strands (inch)	Maximum diameter of stranded conductor (inch)
22	754	694	1.87	19 X 34	0	0.0063	0.033
20	1,216	1,127	1.34	19 X 32	0	0.0080	0.041
18	1,900	1,770	1.34	19 X 30	0	0.0100	0.052
16	2,426	2,261	1.19	19 X 29	0	0.0113	0.061
14	3,831	3,570	1.38	19 X 27	0	0.0142	0.074
12	6,088	5,672	1.67	19 X 25	0	0.0179	0.093
10	9,880	9,208	4.22	49 X 27	0	0.0142	0.128
8	16,983	15,827	2.29	133 X 29	0	0.0113	0.176
6	26,818	24,994	2.31	133 X 27	0	0.0142	0.218
4	42,615	39,715	2.55	133 X 25	0	0.0179	0.272
2	66,500	61,344	3.21	665 X 30	2	0.0100	0.345
1	81,700	75,365	2.89	817 X 30	2	0.0100	0.384
0	104,500	96,397	3.24	1,045 X 30	3	0.0100	0.432
00	133,000	122,687	3.15	1,330 X 30	3	0.0100	0.490
000	167,200	166,500	3.09	1,665 X 30	4	0.0100	0.548
0000	210,900	194,547	3.32	2,109 X 30	5	0.0100	0.615

3.4.1.1.2 Rope lay. Wire sizes 10 through 0000 shall be rope lay as specified in table I and as follows:

- a. Rope-lay stranded conductors shall be laid up concentrically with a center core surrounded by one or more helically wound members. It is optional for the direction of lay for successive layers to be alternately reversed (true concentric lay) or to be in the same direction (unidirectional lay). The length of lay of the outer layer of rope-lay stranded members forming the conductor shall be not less than 8 nor more than 14 times the outside diameter of the completed conductor. The direction of lay of the outside layer may be either left or right hand.
- b. Members of rope-lay stranded conductors: The length of lay of the conductors composing the stranded members shall be not greater than 16 times the outside diameter of the member. Stranding of the individual members may be concentric or bunch.

3.4.1.2 Splices. Splices in individual strands or members shall be butt brazed. There shall be not more than one strand splice in any 10-foot length of a stranded concentric-lay conductor or in any 10-foot length of any member in a rope-lay conductor; except that not more than one splice of an entire member shall be permitted in any 10 feet of a rope-lay conductor. Splices in members of a rope-lay construction shall be so finished that the conductor diameter is not increased at the point of brazing. In no case shall the whole conductor be spliced at one point.

MIL-W-25038F

3.4.2 Insulation.

3.4.2.1 Removability of insulation. The insulation layer, or layers, shall be formed concentrically around the conductor. It shall fit the conductor snugly but strip freely without adherence or damage to the conductor when removed by conventional wire stripping devices.

3.4.2.2 Concentricity. The concentricity shall be not less than 70 percent when measured in accordance with 4.6.2.

3.4.2.3 Color. The color of the outer layer and any stripes shall be in accordance with MIL-STD-104, class 2.

3.5 Finished wire diameter. The diameter of the finished wire shall be as specified (see 3.1).

3.6 Finished wire weight. The weight of the finished wire shall be as specified (see 3.1)

3.7 Performance.

3.7.1 Conductor tensile strength and elongation. Strands removed from the finished wire shall have a tensile strength of not less than 35,000 psi and an elongation of not less than 10 percent for regular strength conductors. For high strength copper alloy conductors, the tensile strength shall not be less than 55,000 psi and the elongation shall not be less than 6 percent. All conductors shall be tested in accordance with 4.6.3.

3.7.2 High temperature endurance. When wire is conditioned as specified in 4.6.4, the resistance of the conductor shall not increase more than 15 percent during conditioning at 650°F (343°C).

3.7.3 Bend. When wire is tested as specified in 4.6.5, there shall be no visible cracks in the insulation.

3.7.4 Wet dielectric. When wire is tested as specified in 4.6.6, there shall be no electrical breakdown (arcing or flashing) between the conductor and salt water.

3.7.5 Conductor resistance. When measured in accordance with 4.6.7, the conductor resistance of the finished wire shall be as specified (see 3.1).

3.7.6 Fluid immersion. When tested as specified in 4.6.8, the wire shall meet the bend and wet dielectric requirements of 3.7.3 and 3.7.4.

3.7.7 Cold bend. When wire is tested as specified in 4.6.9, there shall be no cracking of the outer surface of the insulation and the wire shall meet the dielectric requirements of 3.7.4.

3.7.8 Flame resistance. During the test of 4.6.10, the insulation shall not flake or fall off the conductor. At no time shall the insulation resistance be less than 50 ohms, and the flame travel shall not extend beyond the outer marking bands. If test conductor breakage occurs, the test may be repeated. Conductor breakage does not indicate test failure.

3.7.9 Wicking. When tested as specified in 4.6.11, the indicator solution shall not wick a distance of more than 0.250 inch beyond the 2-inch immersion depth between any layers or components in the insulation.

3.7.10 Thermal shock. When tested as specified in 4.6.12, the wire insulation layer, or layers, shall not exhibit shrinkage or expansion greater than that specified (see 3.1).

3.7.11 Insulation flaws. 100 percent of the finished wire shall be subjected to the dielectric test of 4.6.13. This test shall be performed during the final winding of the wire on shipment spools or reels.

MIL-W-25038F

3.8 Marking. Unless otherwise specified (see 3.1), the finished wire shall be identified by a printed marking applied to the outer surface or visible through the outer surface. The printed identification shall consist of the following, at intervals of 6 inches to 60 inches, as measured from the end of one complete marking to the beginning of the succeeding complete marking.

Specification sheet PIN

Manufacturer's Commercial and Government Entity (CAGE) designation
in accordance with publication H4/HB

The printing shall be green in color in accordance with MIL-STD-104, class 1, except that when the wire is solid green or any other color against which green is difficult to distinguish, the printing shall be white. Identification printing shall be applied with the vertical axes of the printed characters lengthwise of the wire when the nominal diameter of the finished wire is 0.050 inch or smaller. The vertical axes of the printed characters may be either crosswise or lengthwise of the wire when the nominal diameter of the wire exceeds 0.050 inch. All printed characters shall be complete and legible.

3.8.1 Durability of identification. Identification printing, when applied to the outer surface of the finished wire, shall be capable of withstanding the durability test specified in 4.6.14 for the number of cycles and with the weight specified (see 3.1). This test shall not be required when the identification marking is under a clear jacket.

3.9 Workmanship. The wire shall be constructed and finished in accordance with high-grade production techniques. It shall be free from lumps, kinks, splits, abrasions, scraped or corroded surfaces, and skin impurities (see 4.6.1).

4. QUALITY ASSURANCE PROVISIONS

4.1 Responsibility for inspection. Unless otherwise specified in the contractor purchase order, the contractor is responsible for the performance of all inspection requirements (examinations and tests) as specified herein. Except as otherwise specified in the contract or purchase order, the contractor may use his own or any other facilities suitable for the performance of the inspection requirements specified herein, unless disapproved by the Government. The Government reserves the right to perform any of the inspections set forth in this specification where such inspections are deemed necessary to assure supplies and services conform to prescribed requirements.

4.1.1 Responsibility for compliance. All items shall meet all requirements of sections 3 and 5. The inspection set forth in this specification shall become a part of the contractor's overall inspection system or quality program. The absence of any inspection requirements in the specification shall not relieve the contractor of the responsibility of ensuring that all products or supplies submitted to the Government for acceptance comply with all requirements of the contract. Sampling inspection, as part of manufacturing operations, is an acceptable practice to ascertain conformance to requirements, however, this does not authorize submission of known defective material, either indicated or actual, nor does it commit the Government to accept defective material.

4.1.2 Test equipment and inspection facilities. Test and measuring equipment and inspection facilities of sufficient accuracy, quality and quantity to permit performance of the required inspection shall be established and maintained by the contractor. The establishment and maintenance of a calibration system to control the accuracy of the measuring and test equipment shall be in accordance with MIL-STD-45662.

4.1.3 Reliability assurance program. A reliability assurance program shall be established and maintained in accordance with MIL-STD-790. Evidence of such compliance shall be verified by the qualifying activity of this specification at the expenses of the contractor as a prerequisite for qualification and continued qualification.

4.1.4 Statistical process control (SPC). A SPC program shall be established and maintained in accordance with EIA-557. Evidence of such compliance shall be verified by the qualifying activity as a prerequisite for qualification and retention of qualification.

MIL-W-25038F

4.2 Classification of inspections. The inspections specified herein are classified as follows:

- a. Qualification inspection (4.3).
- b. Quality conformance inspection (4.4).

4.2.1 Inspection conditions. Unless otherwise specified in the method, all inspections shall be performed in accordance with the test conditions specified in the applicable section of FED-STD-228.

4.3 Qualification inspections. Qualification inspections in this specification include the initial qualification inspection (4.3.1) and inspection for retention of qualification (4.3.2).

4.3.1 Initial qualification inspections. Initial qualification inspection shall consist of all the test and examinations of table II and the applicable specification sheets. Performance of the inspection shall be the responsibility of the qualification applicant under authorization of the qualifying activity (see 6.3). The qualification applicant shall furnish a copy of his test results and samples of his product to the qualifying activity for verification tests to be performed at the option of the qualifying activity (see 4.3.1.2).

4.3.1.1 Sampling for initial qualification inspection. Finished wire samples of the required length shall be selected for each wire size range for which qualification is desired in the applicable specification sheet. The sample may be any size wire within the specified size range. Ten linear feet of the coated conductor used in the manufacture of the finished wire sample shall be included with the wire sample. When the insulation wall thickness or other construction details vary significantly within a wire range (i.e. MIL-W-25038/3-22), additional sampling may be required at the discretion of the qualifying activity.

<u>Wire size range (AWG)</u>	<u>Required length of wire sample (feet)</u>
22 through 18	200
16 through 12	200
10 through 6	200
4 through 4/0	100

MIL-W-25038F

TABLE II. Qualification and quality conformance inspections.

Examination or test	Requirement paragraph	Test paragraph
Visual and mechanical examination - - - - -	3.1, 3.3 thru 3.4.2.1, 3.4.2.3 thru 3.6, 3.8, and 3.9	4.6.1 4.6.15
Concentricity - - - - -	3.4.2.2	4.6.2
Circular Mil Area - - - - -	3.4.1	4.6.16
Conductor tensile strength and elongation - - -	3.7.1	4.6.3
High temperature endurance ^{1/} - - - - -	3.7.2	4.6.4
Bend - - - - -	3.7.3	4.6.5
Wet dielectric - - - - -	3.7.4	4.6.6
Conductor resistance - - - - -	3.7.5	4.6.7
Fluid immersion ^{2/} - - - - -	3.7.6	4.6.8
Bend - - - - -	3.7.3	4.6.5
Wet dielectric - - - - -	3.7.4	4.6.6
Cold bend - - - - -	3.7.7	4.6.9
Wet dielectric - - - - -	3.7.4	4.6.6
Flame resistance ^{3/} - - - - -	3.7.8	4.6.10
Wicking - - - - -	3.7.9	4.6.11
Thermal shock - - - - -	3.7.10	4.6.12
Insulation flaws - - - - -	3.7.11	4.6.13
Durability of identification - - - - -	3.8.1	4.6.14

^{1/} For quality conformance, test in accordance with 4.6.4.2.

^{2/} Fluid immersion (including bend and wet dielectric tests) is only required for qualification/retention only.

^{3/} For quality conformance, test only one specimen. Fluid immersion is not required.

4.3.1.2 Qualifying activity samples. A set of untested samples with those specified in 4.3.1.1 and taken from the same lot or lots as tested by the manufacturer, shall be forwarded, together with the manufacturer's certified test reports, to the qualifying activity (see 6.3), plainly identified by securely attached, durable tags marked with the following information:

Specification sheet PIN
 Manufacturer's name and CAGE code (Publication H4/H8)
 Manufacturer's PIN
 Comprehensive description of the base materials from which the product is made ^{1/}
 Place and date of manufacture
 Reference; authorization to test letter

4.3.2 Retention of qualification. Except as specified in 4.3.2.2, periodic reinspection of product for retention of qualification shall be made at two-year intervals after the date of the letter notifying the manufacturer of his's products initial acceptance for qualification. Materials from current production shall be inspected against the requirements of table II. Except where certification (4.3.2.2) has been accepted by the qualifying activity, failure of the manufacturer to submit a retention of qualification test report, and if requested, product samples within 30 days after the end of the two year reporting period may result in the removal of the product or products from the Qualified Products List (QPL).

4.3.2.1 Procedure of retention-of-qualification inspection. The qualified manufacturer shall have the responsibility of requesting from the qualifying activity, every two years, authorization to begin the tests for retention of qualification. Unless otherwise specified by the qualifying activity, one wire sample (wire size at the manufacturer's option) for current production shall be tested for each specification sheet. When requested, the manufacturer shall submit a like sample(s) from the same production lot(s) to the qualifying activity.

^{1/} This information will not be divulged by the government.

MIL-W-25038F

4.3.2.2 Retention of qualification by certification. If production of a qualified wire has not occurred since the previous qualification or retention of qualification submission, qualification by certification may be considered. When production resumes following a certification submission, the manufacturer shall request authorization to perform qualification retention tests. No product may be shipped until after approval is given by the qualifying activity. Retention of qualification by certification shall not be permitted for two successive retention of qualification periods.

4.4 Quality conformance inspection. Quality conformance inspection shall be as specified in table II.

4.4.1 Sampling plan. For the examinations and tests specified in table II, a random sample shall be selected from each inspection lot in accordance with MIL-STD-105, acceptable quality level 6.5 percent. The inspection level shall be S-2.

4.4.1.1 Wire flaws test. This test does not lend itself to statistical sampling plans since it is required for 100 percent of the finished wire. The test shall be conducted at the completion of the manufacturing process during the final winding on shipment spools and reels.

4.4.2 Rejected lots. If an inspection lot is rejected, the contractor may rework it to correct the defects, or screen out the defective units, and resubmit for reinspection. Resubmitted lots shall be inspected using tightened inspection. Such lots shall be separate from new lots, and shall be clearly identified as reinspected lots.

4.4.3 Inspection of packaging. The sampling and inspection of the preservation-packaging, packing, and container marking shall be in accordance with the requirements of MIL-C-12000.

4.5 Interpretation of terms. Terms and definitions used for sampling and inspections herein shall be in accordance with MIL-STD-109 and as follows:

4.5.1 Inspection lot. The inspection lot is the collection of units of product from which a sample is drawn and inspected to determine compliance with acceptability criteria, except that the lot for purposes of this specification shall not exceed 300 units of product.

4.5.2 Unit of product. The unit of product for determining lot size under this specification shall be one continuous length of wire as prepared for shipment.

4.5.3 Sample. The sample shall consist of one or more sample units chosen at random from the inspection lot.

4.5.4 Sample unit. A sample unit shall consist of a piece of finished wire chosen at random from the inspection lot and of sufficient length to permit all applicable inspections and tests. A sample unit for quality conformance tests under this specification shall be 75 continuous linear feet of finished wire. Not more than one sample unit shall be taken from a single unit of product.

4.5.5 Specimen. A specimen is a portion of finished wire taken from the sample unit for the performance of a particular inspection or test.

4.6 Methods of examination and test.

4.6.1 Visual and mechanical examination. Wire shall be examined to verify that the materials, design, construction, physical dimensions, marking, and workmanship are in accordance with the requirements specified herein (see 3.1, 3.3 thru 3.4.2.1, 3.4.2.3 thru 3.6, 3.8, 3.9, and 4.6.15).

MIL-W-25038F

4.6.2 Concentricity (see 3.4.2.2). The concentricity of the insulation shall be determined by first locating and recording the minimum wall thickness of a cross section of the insulation. From this point, on the outer rim of the insulation, at which the minimum wall thickness was measured, three more reference points 90 degrees apart on the outside rim of the insulation shall be established. At each of these three reference points, the nearest strand of the conductor shall be selected and the insulation wall thickness between that strand and the outer rim of the insulation shall be measured and recorded. The average of the four measurements shall be considered to be average wall thickness. Concentricity shall be expressed as the ratio of minimum-to-average wall thickness times one hundred. A wall thickness measurement shall be interpreted to be the minimum distance between the outer rim of the insulation and the rim of the outermost strand of the stranded conductor. All wall thickness measurements shall be determined under suitable magnification.

4.6.3 Conductor tensile strength and elongation. After stranding, individual strands shall be tested in accordance with method 3211 of FED-STD-228.

4.6.4 High temperature endurance (see 3.7.2).

4.6.4.1 Qualification high-temperature conditioning and resistance measurement. A suitable length of finished wire from each qualification test sample shall be placed in an air oven which shall be maintained at $650^{\circ} \pm 5^{\circ}\text{F}$ ($343^{\circ} \pm 3^{\circ}\text{C}$). ~~The wire shall be placed in the oven in a manner such that two layers of wire are not touching.~~ Either a circulating or a noncirculating oven may be used. The ends of the specimen that are outside the oven shall be connected to an electric source which may be either ac or dc. The current through the conductor shall be adjusted to stabilize at the value given in table III for the applicable wire size. When the stabilized conductor current is reached, voltage and current measurements shall be recorded. The current loaded wire shall remain in the air oven at an oven temperature of $650^{\circ} \pm 5^{\circ}\text{F}$ ($343^{\circ} \pm 3^{\circ}\text{C}$) for a period of 100 hours. The current through the conductor shall be checked daily and maintained at the required test value. At the end of the 100-hour period, while still at the stabilized temperature and conductor current, a final voltage and current measurement shall be recorded. Change in resistance during the conditioning period shall be calculated from the voltage and current measurements. The wire shall then be cooled to room temperature and examined for visual defects without magnification. Change in color of the finished wire or printed identification shall not be considered a defect. The ends of the wire sample that were outside the oven during conditioning shall be discarded. From the wire which was inside the oven during conditioning, the following 3-foot specimens shall be cut for further testing:

- a. Specimen no. 1 - Bend test (4.6.5) followed by wet dielectric test (4.6.6).
- b. Specimen nos. 2 through 7 - Fluid immersion test (4.6.8) followed by bend test (4.6.5) and wet dielectric test (4.6.6).
- c. Only when specified (see 6.2.f); Specimen nos. 8 and 9 - Fluid immersion test (4.6.8) followed by bend test (4.6.5) and wet dielectric test (4.6.6).

4.6.4.2 Quality conformance high-temperature conditioning and resistance measurement. A coil of finished wire of suitable length from each sample unit shall be conditioned at $650^{\circ} \pm 5^{\circ}\text{F}$ as specified in 4.6.4.1, except that the time of conditioning in the air oven shall be 48 hours. Specimens shall be selected as specified in 4.6.4.1.

MIL-W-25038F

TABLE III. Current for conditioning.

Size	Test current
22	4.5
20	5.5
18	9.0
16	11.5
14	16.5
12	21.0
10	28.5
8	37.5
6	52.0
4	70.0
2	94.0
1	105.0
0	127.0
00	146.0
000	169.0
0000	202.0

4.6.5 Bend (see 3.7.3). This test shall be conducted at room temperature. One end of a 3-foot specimen shall be secured to a mandrel and the other end weighted. The mandrel diameter and test load shall be as specified (see 3.1). The mandrel shall be rotated until the full length of the specimen is wrapped around the mandrel. The process shall be repeated in reverse until the full length of the specimen is again wrapped around the mandrel with the surface of the specimen previously outside during the first wrapping now next to the mandrel. This procedure shall be repeated until two bends in each direction have been formed in the same section of the specimen. At the completion of the test, the insulation of the specimen shall be examined for visible cracks without magnification.

4.6.6 Wet dielectric (see 3.7.4). One inch of insulation shall be stripped from each end of a 3-foot specimen of wire, and these uninsulated ends shall be fastened in metallic contact to a metal bar. The diameter of the bend shall be not greater than 40 times the diameter of the specimen. The center 24-inch section of the prepared specimen shall be immersed in a 5-percent solution of sodium chloride in tap water, at room temperature, for not less than 5 hours. At the end of this immersion period, a potential of 1,500 Vrms at 60 Hz shall be applied for 1 minute between the conductor and an electrode in the salt solution.

4.6.7 Conductor resistance (see 3.7.5). Conductor resistance of the finished wire shall be measured in accordance with method 6021 of FED-STD-228.

4.6.8 Fluid immersion (see 3.7.6). Each of the remaining specimens of wire (see 4.6.4.1 and 4.6.4.2) shall have its center 2-foot section immersed in a fluid for 8 hours, using a separate specimen for each fluid.

- a. Specimen no. 2: Aviation gasoline conforming to ASTM D910, grade 80.
- b. Specimen no. 3: Hydraulic fluid conforming to MIL-H-5606 at 120° ±2°F (49° ±1°C).
- c. Specimen no. 4: Turbine fuel conforming to MIL-T-5624, grade JP-4, at room temperature.
- d. Specimen no. 5: Lubricating oil conforming to MIL-L-7808, at 120° ±2°F (49° ±1°C).
- e. Specimen no. 6: Hydraulic fluid conforming to MIL-H-8446, at 120° ±2°F (49° ±1°C).
- f. Specimen no. 7: Lubricating oil conforming to MIL-L-23699, at 120° ±2°F (49° ±1°C).
- g. Specimen no. 8: MIL-D-50030, at room temperature. *
- h. Specimen no. 9: MIL-D-12468, at room temperature. *

* NOTE: For Air Force and Army applications only, the following shall apply:

When specified by program requirement standards [i.e. MIL-A-87244(USAF)], wire for flight critical applications shall be tested with these additional fluids.

MIL-W-25038F

During the immersion, the bend in each specimen shall have a diameter no greater than 40 times the diameter of the specimen. Upon removal from the fluids, the specimens shall be wiped with a clean cloth and shall remain not less than 1 nor more than 2 hours in free air at room temperature after which time all specimens shall be subjected to and pass the bend test (see 4.6.5) without failure, followed by the wet dielectric test (see 4.6.6). Failure of the test specimens to pass these tests shall be cause for rejection.

4.6.9 Cold bend (see 3.7.7). For the purpose of this test, a revolving mandrel capable of being operated from outside the cold chamber shall be used. The mandrel diameter and the test load shall be as specified (see 3.1). One end of each specimen shall be secured to the mandrel and the other end weighted. The mandrel and the specimens shall be placed in a cold chamber and the temperature of the chamber lowered to $-65^{\circ} \pm 5^{\circ}\text{F}$ ($-54^{\circ} \pm 3^{\circ}\text{C}$). After maintaining this temperature for 4 hours and while still at this low temperature, the specimens shall be bent around 180 degrees of the mandrel without opening any access door to the cold chamber. The time required for bending the sample around 180 degrees of the mandrel shall be 1/2 minute at a uniform rate of speed. The specimens shall be allowed to return to room temperature, without straightening, and examined for visual defects. Each specimen shall then be subjected to the wet dielectric test specified in 4.6.6.

4.6.10 Flame resistance (see 3.7.8).

4.6.10.1 Preparation of specimens. A 24-inch specimen shall have its center 18-inch section immersed for 24 hours at room temperature in aviation gasoline conforming to ~~ASTM D 910~~ grade 80. A second specimen shall be immersed in like manner for 24 hours at room temperature in a solution of 50 percent turbine fuel conforming to MIL-T-5624, grade JP-4, teuhia oil (lub) and 50 percent aircraft lubricating oil conforming to MIL-L-6082, grade 1100. A third specimen shall be suspended for 4 hours in the vapors of aircraft lubricating oil conforming to MIL-L-6082, grade 1100, which shall be maintained at a temperature of 250°F (121°C). Upon removal from the liquid and after wiping with a clean cloth, wire bands consisting of one turn of wire, no larger than size 30, shall be wrapped around each specimen, thus designating its 7-inch middle section, plus an additional outer band 4 inches outside each of these two bands.

4.6.10.2 Apparatus. Each specimen shall then be mounted in the rack with the center 7-inch section so located that it shall be centered 1 inch above the burner top plate as shown on figure 1. Each of the two nickel-chrome ribbons shall be wrapped once around the specimen snugly with the edges butted together. The two ribbons shall be 1 inch apart at the midsection of the 7-inch section as illustrated on figure 1. The conductor of the specimen and the nickel-chrome ribbons shall be connected in the test circuit as shown on figure 1. A shorting bar shall be inserted between the nickel-chrome ribbons and the conductor, and the meter adjusted to read approximately zero ohm.

MIL-W-25038F

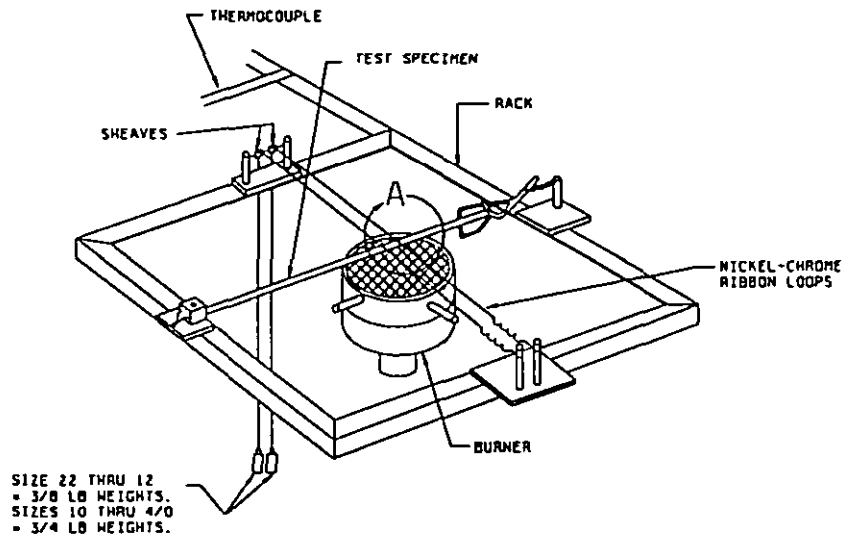
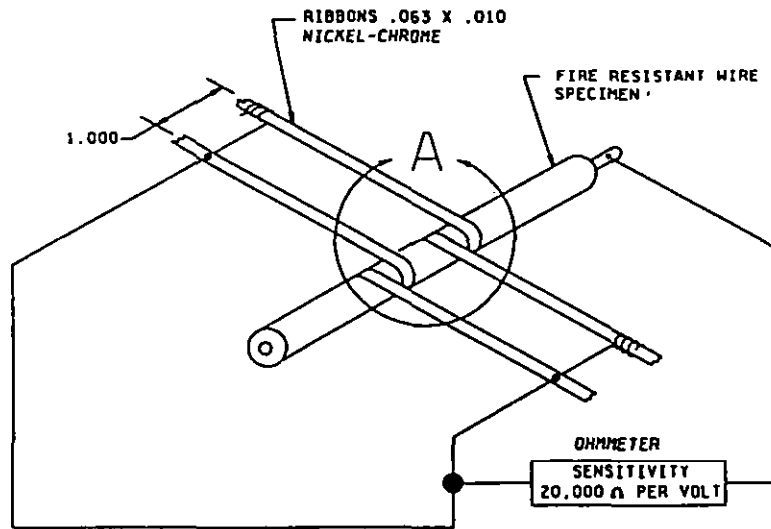

Inches	mm
.010	0.25
.063	1.60
1.000	25.40

NOTES:

1. Dimensions are in inches.
2. Metric equivalents are given for information only.
3. Unless otherwise specified, tolerance is $\pm .005$ (0.13 mm).

MIL-W-25038F

FIGURE 1. Flame test fixture.

4.6.10.3 Burner adjustment. The thermocouple shall be located in a plane 1 inch above the burner top plate, near the center of the burner. The burner, figure 2, shall be ignited and the flow of gas, air, and secondary air shall be adjusted to give a nonoxidizing, nonreducing (neutral) flame approximately 1 inch high with a flame temperature, as measured by the thermocouple, of $2,000^{\circ} \pm 50^{\circ}\text{F}$ ($1,093^{\circ} \pm 27^{\circ}\text{C}$).

CAUTION: The proper flame will be obtained by using a minimum amount of gas and secondary air. The flame shall be uniform over the top of the top plate area (this is achieved mainly by adjustment of secondary air), and the tip of the blue cone shall be approximately 1 inch above the burner top plate. The burner shall be run until a stable temperature and flame have been achieved before starting any test. The tip of each flame shall not be yellow; to achieve this, for each gas valve adjustment, the air valve shall be opened to the point just beyond that which gives a yellow-tipped flame.

4.6.10.4 Vibration. After the flame has stabilized, the specimen shall be vibrated at approximately 30 Hz with the rack having a maximum total excursion of approximately 0.06 inch.

4.6.10.5 Test procedure. After removing the thermocouple, the vibrating specimen shall be positioned in the stabilized flame so that the lower surface of the specimen is at the same position in the flame as that previously occupied by the hot junction of the thermocouple, and so that the 7-inch midsection is centered over the burner top plate. The specimen shall remain in this position in the flame for a 15-minute test period. With the ohmmeter observed continuously during this period, the minimum reading shall be recorded. At the end of the 15-minute period, the burner shall be repositioned under the thermocouple and the flame temperature checked.

4.6.11 Wicking (see 3.7.9). A specimen of each finished wire and cable size to be tested shall be cut 6 \pm 1/16 inch with square ends. The specimen shall be vertically immersed for 2 inches of its length in Esterlin Angus, Medium Dry, Red Instrument Ink, which is contained in an open test tube, and conditioned for 24 hours at room temperature in a draft-free room. After this conditioning, the ink on the surface shall be removed immediately from the 2 inches immersed by wiping gently with a clean, dry, lint-free cloth. The specimen shall then be examined for wicking between insulation layers. The distance that the ink has wicked above the 2-inch immersed portion of the specimen shall be recorded as the distance of wicking.

4.6.12 Thermal shock (see 3.7.10).

4.6.12.1 Preparation of specimen. A specimen of wire 5 feet long shall be prepared by carefully removing 1 inch of insulation from each end of the wire. (For purposes of this test, insulation is defined as all layers of nonconducting material covering the electrical conductor, i.e., primary insulation, all tapes and braids, and the jacket.) A razor blade, or equivalent, held perpendicular to the axis of the wire, should be used to cut the insulation for the removal operation. The length of exposed conductor at each end of the specimen shall be measured to the nearest 0.01 inch. The specimen shall be formed into a loose coil not less than 1 foot in diameter and shall be laid on a wire screen for handling throughout the test.

4.6.12.2 Test procedure. The specimen shall be placed for 30 minutes in an air-circulating oven, preheated to $500^{\circ} \pm 4^{\circ}\text{F}$ ($260^{\circ} \pm 2^{\circ}\text{C}$). It shall then be removed from the oven and within 2 minutes shall be placed in a chamber which has been precooled to $-67^{\circ} \pm 4^{\circ}\text{F}$ ($-55^{\circ} \pm 2^{\circ}\text{C}$). The specimen shall be exposed to this temperature for 30 minutes, after which it shall be removed and allowed a minimum of 30 minutes to return to room temperature, 68° to 77°F (20° to 25°C). At the conclusion of this cycle, the distance from the end of each layer of insulation to the end of the conductor shall be measured to the nearest 0.01 inch. This thermal shock cycle and the measurements shall be repeated for an additional three cycles (a total of four cycles). Any measurement varying from the original measurement by more than that specified in 3.7.10 shall constitute failure.

4.6.13 Insulation flaws (see 3.7.11). One hundred percent of the finished wire shall pass through a suitable spark-test device that will give intimate metallic contact with practically all of the wire insulation surface and impress the insulation to an ac potential of 2,500 Vrms at 60 Hz or 3 KHz in accordance with NEMA WC 56. Electrode length and speed of wire through the electrode shall be such that the insulation will be subjected to the test voltage for a minimum of 0.2 second. Any portion of the wire failing this test shall be cut out of the finished wire before final spooling.

4.6.14 Durability of identification. The durability of product identification or color markings applied to the wire for coding shall be evaluated at 68° to 77°F (20° to 25°C) as follows:

MIL-W-25038F

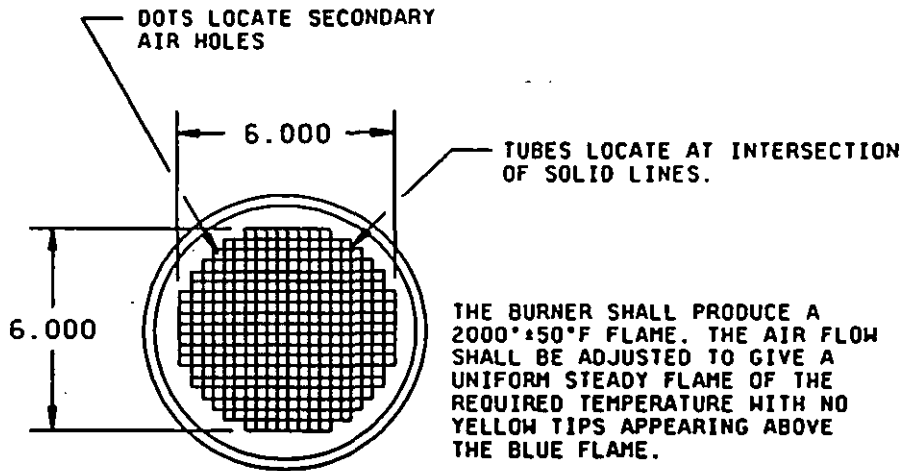

TOP PLATE DETAIL

Inches	mm
.1015	2.578
.125	3.18
.312	7.92
.625	15.88
1.000	25.40
1.500	38.10
6.000	152.40
7.000	177.80
7.625	193.68

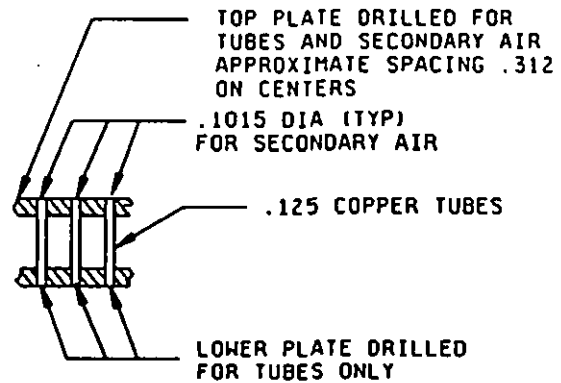
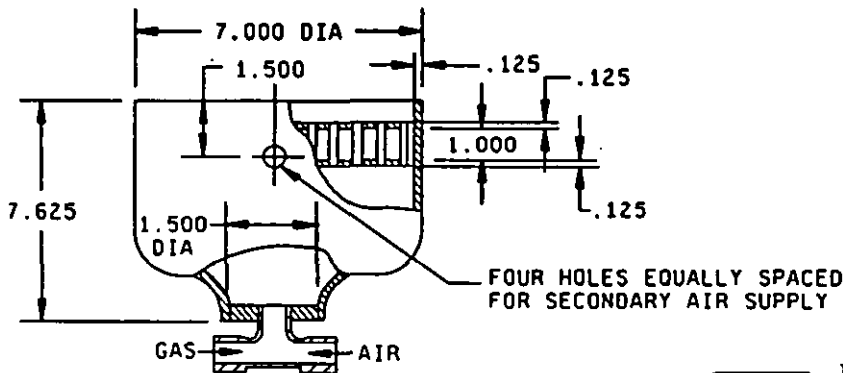

TUBING DETAIL

NOTES:

1. Dimensions are in inches.
2. Metric equivalents are given for information only.
3. Unless otherwise specified, tolerance is $\pm .005$ (0.13 mm).

FIGURE 2. Burner details.

MIL-W-25038F

4.6.14.1 Durability testing apparatus. The markings durability tester shall be designed to hold a short specimen of finished wire firmly clamped in a horizontal position with the upper longitudinal surface of the specimen fully exposed. The instrument shall be capable of rubbing a small cylindrical steel mandrel (usually a needle), 0.025 inch in diameter, repeatedly over the upper surface of the wire, in such position that the longitudinal axes of the mandrel and the specimen are at right angles to each other with cylindrical surfaces in contact. A weight affixed to a jig above the mandrel shall control the force exerted normal to the surface of the insulation. A motor-driven, reciprocating cam mechanism and counter shall be used to deliver an accurate number of abrading strokes in a direction parallel to the axis of the specimen. The length of the stroke shall be 3/8 inch and the frequency shall be 120 strokes (60 stroking cycles) per minute.

4.6.14.2 Durability testing procedure. In performing the test, a specimen of finished wire shall be mounted in the specimen clamp and the jig shall be adjusted to deliver a weight of 500 grams through the abrading mandrel to the markings on the insulation. The specimen shall be subjected to 125 abrasion cycles (250 strokes) of the mandrel and shall then be examined using the naked eye. If there is a continuous line of erasure or obliteration through the stripe, band or printed identification marking, exposing the primary insulation, the specimen shall be considered as having failed. Three specimens shall be tested for each sample unit and failure of any specimen shall constitute failure of the sample unit.

4.6.15 Finished wire weight. The weight of the finished wire shall be as specified (see 3.1). The weight of each lot of finished wire shall be determined by procedure I. Lots failing to meet the wire weight requirement in accordance with procedure I shall be subjected to procedure II. All reels or spools failing to meet the requirements of the applicable specification sheet shall be finally rejected. The sampling plan of 4.4.1 shall not apply to procedure II.

4.6.15.1 Procedure I. The length and weight of a specimen at least 10 feet long shall be accurately measured with the resultant measurements transposed to pounds per 1,000 feet.

4.6.15.2 Procedure II. The net weight of the finished wire on each reel or spool shall be obtained by subtracting the tare weight of the reel or spool from the gross weight of the reel or spool containing the finished wire. The net weight of wire on each reel or spool shall be divided by the accurately determined length of finished wire on that reel or spool and the result transposed to pounds per 1,000 feet. When wood or moisture absorbent materials are used for reel or spool construction, weight determinations shall be made under essentially the same conditions of relative humidity.

4.6.16 Circular Mil Area (CMA). Before the application of any insulation, the stranded conductor shall be tested for in accordance with ASTM B 263. Requirements for minimum and appropriate K-values are listed in table I.

5. PACKAGING

5.1 Packaging requirements. The requirements for packaging shall be in accordance with MIL-C-12000.

5.1.1 Reels and spools. Wire shall be delivered wound on nonreturnable reels or spools, each having an appropriate diameter for the respective size. In no case shall the barrel of the reel or spool be less than 5-1/2 inches in diameter. The footage of individual continuous wire lengths shall be marked on each reel or spool in the sequence of unwinding.

5.1.2 Wire length. Unless otherwise specified (see 6.2), no less than 85 percent of the total quantity of each size of wire ordered shall be in lengths equal to or greater than the nominal length specified in table IV. No wire will be accepted in lengths shorter than the specified minimum acceptable length. The maximum quantity of wire in a single length shall be limited only by manufacturing and handling facilities.

TABLE IV. Wire lengths.

Wire size (AWG)	Nominal length on reel or spool (feet)	Minimum acceptable length (feet)
22 to 6, incl	500	100
4 to 2, incl	250	50
1 to 0000, incl	100	25

MIL-W-25038F

5.1.3 Marking. In addition to the marking specified in MIL-C-12000, special marking shall include the following:

- a. Number of this specification.
- b. Military PIN.
- c. Wire size.
- d. Date of manufacture.
- e. Name of manufacturer.

6. NOTES

(This section contains information of a general or explanatory nature that may be helpful, but is not mandatory.)

6.1 Intended use. The basic insulated wire covered by this specification is intended for use in circuits where it is necessary to maintain the electrical integrity of the insulated conductor for 15 minutes in a 2,000°F (1,093°C) flame, with the operating potentials not exceeding 125 Vrms.

6.2 Acquisition requirements. Acquisition documents must specify the following:

- a. Title, number, and date of this specification.
- b. Issue of DODISS to be cited in the solicitation, and if required the specific issue of individual documents referenced (see 2.1).
- c. Military PIN of wire to be furnished.
- d. If a different quantity (linear feet) per reel or spool is desired (see 5.1.2).
- e. Applicable specification sheet number, title, and date.
- f. For Army and Air force flight critical applications with MIL-A-87244(USAF) requirements: Specify that quality conformance inspection tests must include two additional test specimens for immersion in decontaminating fluids, and testing per paragraphs 4.6.B (fluid immersion) and 4.6.4 (high temperature endurance testing).

6.3 Qualification. With respect to products requiring qualification, awards will be made only for products which are, at the time of award of contract, qualified for inclusion in Qualified Products List QPL No. 25038 whether or not such products have actually been so listed by that date. The attention of the contractors is called to these requirements, and manufacturers are urged to arrange to have the products that they propose to offer to the Federal Government tested for qualification in order that they may be eligible to be awarded contracts or purchase orders for the products covered by this specification. The activity responsible for the Qualified Products List is the 645 LOG/ESP Gentile Station, 1060 Hamilton Street, Dayton, Ohio 45444-5400; however, information pertaining to qualification of products may be obtained from Commanding Officer, Naval Air Warfare Center, Code DP704N, 6000 East 21st Street, Indianapolis, IN 46219-2189.

6.3.1 It is understood that wire supplied under contract shall be identical in every respect to the sample tested and found satisfactory, except for changes previously approved by the Government. Any unapproved changes from the qualification sample shall constitute cause for rejection.

6.4 Changes from previous issue. The text of this specification has been highlighted to indicate where changes (additions, modifications, corrections) from the previous issue were made. This was done as a convenience only and the Government assumes no liability whatsoever for any inaccuracies in these notations. Bidders and contractors are cautioned to evaluate the requirements of this document based on the entire content irrespective of the textual notations and relationship to the previous issue.

6.5 Key word listing.

Polytetrafluoroethylene
 Flame resistant
 Tensile strength
 Wicking
 Wet dielectric
 High-temperature endurance

MIL-W-25038F

CONCLUDING MATERIAL

Custodians:
Army - CR
Navy - AS
Air Force - 85
NASA - NA

Review activities:
Army - AV, MI, AR
Air Force - 17, 99
DLA - ES, IS
NSA - NS

User activities:
Army - ME
Navy - OS

Preparing activity:
Air Force - 85

Agent:
DLA - ES

(Project 6145-2031)

STANDARDIZATION DOCUMENT IMPROVEMENT PROPOSAL

INSTRUCTIONS

1. The preparing activity must complete blocks 1, 2, 3, and 8. In block 1, both the document number and revision letter should be given.
2. The submitter of this form must complete blocks 4, 5, 6, and 7.
3. The preparing activity must provide a reply within 30 days from receipt of the form.

NOTE: This form may not be used to request copies of documents, nor to request waivers, or clarification of requirements on current contracts. Comments submitted on this form do not constitute or imply authorization to waive any portion of the referenced document(s) or to amend contractual requirements.

I. RECOMMEND A CHANGE:

1. DOCUMENT NUMBER
MIL-W-25038F

2. DOCUMENT DATE (YYMMDD)

3. DOCUMENT TITLE

Wire, Electrical, High Temperature, Fire Resistant, and Flight Critical, General Specification for

4. NATURE OF CHANGE (Identify paragraph number and include proposed rewrite, if possible. Attach extra sheets as needed.)

5. REASON FOR RECOMMENDATION

6. SUBMITTER

a. NAME (Last, First, Middle initial)

b. ORGANIZATION

c. ADDRESS (Include Zip Code)

d. TELEPHONE (Include Area Code)

7. DATE SUBMITTED
(YYMMDD)

(1) Commercial
(2) AUTOVON
(if applicable)

B. PREPARING ACTIVITY

a. NAME Electronic Support Division
645 LOG/ES

b. TELEPHONE (Include Area Code)
(1) Commercial (513) 296-5517 (2) AUTOVON 986-5517

c. ADDRESS (Include Zip Code)
Gentile Air Force Station
1060 Hamilton Street
Dayton, OH 45444-5400

IF YOU DO NOT RECEIVE A REPLY WITHIN 45 DAYS, CONTACT:
Defense Quality and Standardization Office
5203 Leesburg Pike, Suite 1403, Falls Church, VA 22041-3466
Telephone (703) 756-2340 AUTOVON 289-2340