

MIL-W-12133/9  
9 October 1987

## MILITARY SPECIFICATION SHEET

## WASHER, SPRING TENSION, CURVED, COPPER-BERYLLIUM

This specification is approved for use by all Departments and Agencies of the Department of Defense.

The requirements for acquiring the washers described herein shall consist of this specification and the latest issue of MIL-W-12133.

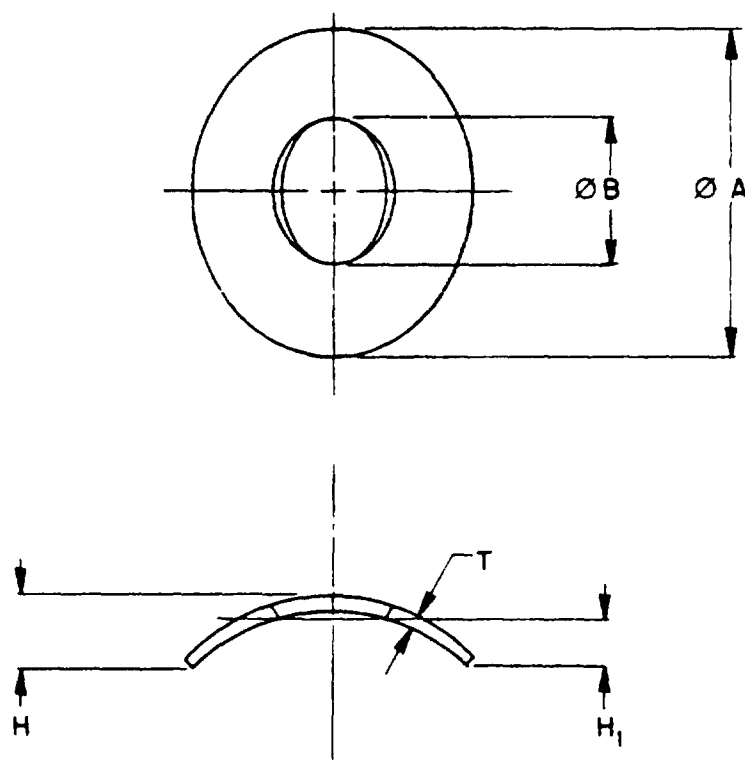

## NOTES:

1. All dimensions are in inches.
2. Lettered dimensions are listed in Table I herein.

FIGURE 1. WASHER, SPRING TENSION, CURVED, COPPER-BERYLLIUM

MIL-W-12133/9

REQUIREMENTS:

1. Material. Copper-Beryllium alloy, numbers 170 or 172 (UNS C17000 or UNS C17200) in accordance with QQ-C-533.
2. Surface hardness. 35-40 HRC.
3. Protective coating and surface treatment. Cadmium plate or Plain.
4. Part number. The part number consists of the letter "M", the basic number of this specification sheet, followed by a dash number taken from Table I, and a finish code letter.

EXAMPLE: M12133/9-09P

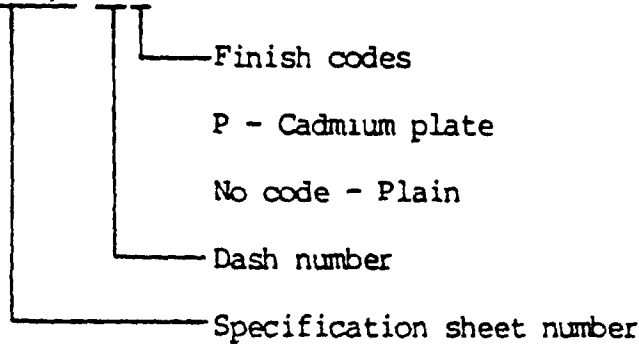

M12133/9-09P Indicates - Washer, Spring Tension, Curved, Copper-Beryllium; .133 ID; .250 OD; .006 thick.

MIL-W-12133/9

TABLE I. DASH NUMBERS AND DIMENSIONS.

DASH NO.	$\phi A$ OD +.010	$\phi B$ ID +.005	T THICKNESS +.001	H FREE WEIGHT +.008	$H_1$ DEFLECTION	LOAD AT $H_1$ +15% (LBS)
01	.183	.059	.005	.047	.011	2.0
02	.130	.084	.008	.035	.003	2.7
03	.140	.096	.003	.031	.011	.3
04	.273	.112	.005	.047	.024	1.7
05	.378	.122	.008	.047	.029	5.2
06	.250	.125	.008	.047	.013	3.8
07	.176	.127	.010	.032	.005	3.3
08	.230	.128	.008	.047	.011	3.4
09	.250	.133	.006	.032	.016	1.9
10	.312	.136	.006	.062	.026	2.4
11	.283	.137	.008	.047	.016	3.9
12	.640	.147	.005	.062	.057	1.0
13	.312	.155	.010	.062	.016	6.0
14	.249	.161	.011	.047	.010	4.2
15	.312	.189	.005	.062	.039	1.0
16	.565	.204	.025	.052	.021	48
17	1.065	.252	.015	.093	.078	22
18	.497	.254	.006	.100	.067	2.1
19	.691	.259	.006	.070	.064	1.3
20	.495	.260	.007	.125	.057	2.7
21	.437	.263	.012	.062	.026	7.0
22	.551	.296	.010	.085	.049	5.6
23	.465	.377	.006	.093	.058	1.0
24	.623	.439	.012	.093	.052	5.0
25	.750	.505	.015	.130	.059	8.5

MIL-W-12133/9

Custodians:

Army - AR

Navy - OS

Air Force - 99

Preparing Activity:

Army - AR

Agent:

DLA - IS

Review Activities:

Army - AT, ER, MI

Navy - AS

Air Force - 11,82

DLA - IS

(Project 5310-1509)

User Activities:

Army - CR

Navy - MC, YD