

INCH-POUND

MIL-S-81963B
28 November 1990SUPERSEDING
MIL-S-81963A
1 August 1985

**MILITARY SPECIFICATION
SERVOCOMPONENTS, PRECISION INSTRUMENT,
ROTATING, COMMON REQUIREMENTS AND
TESTS
GENERAL SPECIFICATION FOR**

This specification is approved for use by all Departments
and Agencies of the Department of Defense.

1. SCOPE

1.1 Scope. This specification covers common requirements and tests for analog, digital and analog/digital precision instrument rotating servocomponents (synchros, electrical resolvers, electrical linear resolvers, transolvers, shaft angle encoders, servomotors, tachometer-generators, servomotor-tachometer generators, stepping motors, and gearheads). This specification shall be used with the applicable general specification which covers a particular class of servocomponents (for example, synchros), together with the specification sheet detailing the specific requirement for the individual servocomponent.

2. APPLICABLE DOCUMENTS

2.1 Government documents.

- * 2.1.1 Specifications, standards, and handbooks. The following specifications, standards and handbooks form a part of this specification to the extent specified herein. Unless otherwise specified, the issues of these documents shall be those listed in the issue of the Department of Defense Index of Specifications and Standards (DoDISS) and supplement thereto, cited in the solicitation.

Beneficial comments (recommendations, additions, deletions) and any pertinent data which may be of use in improving this document should be addressed to: Systems Engineering and Standardization Department (Code 53), Naval Air Engineering Center, Lakehurst, NJ 08733-5100, by using the self-addressed Standardization Document Improvement Proposal (UD Form 1426) appearing at the end of this document or by letter.

* AMSC - N/A

FSC 5990

* DISTRIBUTION STATEMENT A. Approved for public release; distribution is unlimited.

MIL-S-81963B

SPECIFICATIONS

FEDERAL

J-W-1177	Wire, Magnet, Electrical
QQ-A-250/4	Aluminum Alloy, 2024, Plate and Sheet
QQ-B-637	Brass, Naval, Rod, Wire, Shapes, Forging, and Flat Products with Finished Edges, Bar, Flat Wire, and Strip

MILITARY

MIL-A-8625	Anodic Coatings for Aluminum and Aluminum Alloys
MIL-S-12134	Synchros, Resolvers, and Servo Motors, Packaging of
MIL-W-16878/4	Wire, Electrical, Polytetrafluoroethylene (PTFE) Insulated, 200°C, 600 Volts, Extruded Insulation
MIL-W-16878/6	Wire, Electrical, Polytetrafluoroethylene (PTFE) Insulated, 200°C, 250 Volts, Extruded Insulation
MIL-S-20708	Synchros, General Specification for
MIL-S-22432	Servomotor, General Specification for
MIL-S-22820	Servomotor-Tachometer-Generator AC, General Specification for
MIL-T-22821	Tachometer-Generator AC, General Specification for
MIL-R-23417	Resolver, Electrical, General Specification for
MIL-R-50781	Resolvers, Electrical, Linear, General Specification for
MIL-E-81512	Encoder, Shaft Position to Digital, Contact Type, Altitude Reporting, General Specification for
MIL-B-81793	Bearing, Ball, Precision, For Instrument and Rotating Components
MIL-T-83727	Transolver, General Specification for

MIL-S-81963B

STANDARDS

FEDERAL

FED-STD-H28/2 Screw Thread Standards for Federal Services,
Section 2, Unified Inch Screw Threads - UN and
UNR Thread Forms

MILITARY

MIL-STD-105 Sampling Procedures and Tables for Inspection
by Attributes

MIL-STD-130 Identification Marking of U.S. Military
Property

MIL-STD-202 Test Methods for Electronic and Electrical
Component Parts

MIL-STD-454 Standard General Requirements for Electronic
Equipment

MIL-STD-461 Electromagnetic Emission and Susceptibility
Requirements for the Control of Electromagnetic
Interference

MIL-STD-462 Electromagnetic Interference Characteristics,
Measurement of

MIL-STD-740(SH) Airborne and Structureborne Noise Measurement
and Acceptance Criteria of Shipboard Equipment

* MIL-STD-1250(MI) Corrosion Prevention and Deterioration Control
in Electronic Components and Assemblies

* (Unless otherwise indicated, copies of the federal and military specifications, standards and handbooks are available from the Naval Publications and Forms Center (ATIN: Documents Order Desk), Bldg. 4D, 700 Robbins Avenue, Philadelphia, PA 19111-5094.)

* 2.2 Non-Government publications. The following documents form a part of this specification to the extent specified herein. Unless otherwise specified, the issues of the documents which are DoD adopted are those listed in the issue of the DODISS cited in the solicitation. Unless otherwise specified, the issues of documents not listed in the DODISS are the issues of the documents cited in the solicitation (see 6.2).

MIL-S-81963B

AMERICAN NATIONAL STANDARDS INSTITUTE (ANSI)

- * ANSI S1.11 Specification for Octave, Half-Octave, and Third-Octave Band Filter Sets
- * ANSI Y-14.5M Dimensioning and Tolerancing

(Application for copies should be addressed to the American National Standards Institute, 1430 Broadway, NY 10018.)

NATIONAL BUREAU OF STANDARDS (NBS)

NBS Handbook 100 Copper Wire Table (International Annealed Copper Standard)

(Application for copies should be addressed to the U.S. Department of Commerce, National Bureau of Standards, Washington, DC 20234.)

AMERICAN SOCIETY FOR TESTING AND MATERIALS (ASTM)

- * ASTM A582 Free Machining Stainless and Heat-Resisting Steel Bars, Hot-Rolled or Cold-Finished
- * ASTM E18 Rockwell Hardness and Rockwell Superficial Hardness of Metallic Materials, Test Methods for

(Application for copies should be addressed to the American Society for Testing and Materials, 1901 Race Street, Philadelphia, PA 19103.)

* (Non-Government standards and other publications are normally available from the organizations that prepare or distribute the documents. These documents may also be available in or through libraries or other informational services.)

* 2.3 Order of precedence. In the event of a conflict between the text of this specification and the references cited herein, the text of this specification shall take precedence. Nothing in this specification, however, supersedes applicable laws and regulations unless a specific exemption has been obtained.

3. REQUIREMENTS

3.1 Detail requirements. Detail requirements for individual servo-components shall rank in the following order of precedence:

- a. Specification sheet.
- b. The general specification for the particular class of servocomponents.
- c. This specification.
- d. Referenced documents.

MIL-S-81963B

3.2 Qualification. Servocomponents furnished under the applicable servocomponent general specification shall be products which are qualified for listing on the applicable Qualified Products List (QPL) at the time set for opening of bids (see 4.6 and 6.10).

3.3 First article. When required by the contracting activity, servocomponents shall conform to the requirements specified herein and shall have met the first article inspection specified in 4.7 prior to the regular production on a contract (see 6.3).

3.4 Parts, materials and processes.

3.4.1 Parts, materials and processes. Whenever possible, parts and materials shall be selected from those specified herein. If a suitable material is not listed, a material shall be used which will permit the servocomponent to meet all the requirements of this specification. Materials used in the construction or packaging of servocomponents shall not produce corrosive, toxic or otherwise deleterious fumes or vapors which could precipitate upon or attack parts or personnel. Acceptance or approval of any constituent material shall not be construed as a guarantee of the acceptance of the finished product.

3.4.2 Housing, rotor shaft. Housing and rotor shaft material shall be corrosion resistant steel conforming to ASIM A582-80, Type 416 (UNS S14600). The housing is considered to include front and rear end bells, bearing seats, and any other structural supporting parts. The shaft shall have a hardness conforming to ASIM E18, appropriate to the servocomponent as follows:

Where the shaft splining is not to be used as a primary pinion, such as synchros and resolvers	20HRC to 32HRC
Where the shaft is designed to be used as the primary pinion, such as servomotors	28HRC to 35HRC

3.4.3 Insulating materials. Insulating materials shall be in accordance with Requirement 11 of MIL-STD-454.

* 3.4.4 Plastics. Plastics shall be of such composition and workmanship as to enable the servocomponent to conform to all requirements of this specification.

* 3.4.5 Impregnating and potting compounds. Compounds shall be in accordance with Requirement 47 of MIL-STD-454. The compound shall not crack or flow under the temperature range referenced in the applicable general specification.

MIL-S-81963B

3.4.6 Dissimilar metals. Dissimilar metals shall not be used in intimate contact with each other unless suitably protected against electrolytic corrosion. When it is necessary for any combination of dissimilar metals to be assembled, a material compatible with each shall be interposed between them. For classification purposes metals are grouped as follows:

<u>Group 1</u>	<u>Group 2</u>	<u>Group 3</u>	<u>Group 4</u>
Most anodic metals	Aluminum Aluminum alloys Zinc Cadmium Tin Corrosion-resistant steel	Zinc Cadmium Steel Lead Tin Corrosion-resistant steel	Copper and its alloys Nickel and its alloys Chromium Corrosion-resistant steel Gold Silver (Cathodic) Most Cathodic metals

a. Contact between a member of one group and another member of the same group shall be considered as being similar. Contact between a member of one group and a member of any other group shall be considered as being dissimilar except for zinc, tin and cadmium as listed in Groups 2 and 3, and corrosion-resistant steel as listed in Groups 2, 3 and 4.

b. All metals not listed in the above grouping shall be considered as being dissimilar not only to each other but also to any member of any group.

c. The above grouping shall not be construed as waiving requirements relating to the corrosion-resistance treatment of parts and assemblies. Care shall be exercised in using aluminum alloys against each other or against differing materials.

d. Where reference is made in the above grouping to a certain member in a particular group the reference applies to the metal on the surface of the part such as zinc means zinc casting, zinc electroplate, zinc hot dip or zinc metal spray.

e. If any corrosion is anticipated between different metals in contact, even though they are similar, the metals shall be assembled in such a manner that the smaller part is cathodic and protected, and the larger part is anodic or corrodible.

f. Certain qualified standard or approved nonstandard parts and attaching hardware shall have tin or nickel-plate finish. These parts may be mounted on a chassis without additional protection from corrosion.

3.4.7 Electrolytic corrosion protection. Where it is unavoidable that combinations of dissimilar metals be in contact, the following methods or combinations of methods shall be employed unless electrical consideration precludes their use.

MIL-S-81963B

a. A material shall be interposed between the metals so as to reduce electrolytic potential differences, such as steel in contact with aluminum should be cadmium plated.

b. An inert material shall be interposed between dissimilar metals to act as an insulating barrier.

c. Corrosion inhibitors shall be applied to the faces of each of the dissimilar metals; for example, nickel-plated brass screws in contact with aluminum shall be coated with zinc chromate paste.

* d. The contact areas of each of the dissimilar metals shall be coated with an organic coating in accordance with MIL-SID-1250(MI); for example, aluminum and steel surfaces in contact should be painted.

e. The requirements of 3.4.5e shall apply.

f. The amount of aeration reaching the dissimilar contact areas shall be restricted; for example, steel bolts in contact with aluminum should have all contact surfaces sealed with zinc chromate primer or with a vinyl or equivalent film.

g. Any other systems of protection which are designed to alleviate electrolytic corrosion shall be subject to the approval of the procuring activity.

* 3.4.8 Aluminum. All parts made of aluminum or aluminum alloys shall be anodized in accordance with MIL-A-8625.

3.4.9 Restricted materials. Flammable or explosive material, magnesium or magnesium alloys, material which can produce toxic or suffocating fumes (see 3.4.1), cotton, linen, cellulose nitrate, regenerated cellulose, wood (untreated), jute, leather, cork, organic fiberboard, paper and cardboard, hair or wool felts, plastic materials employing paper, cotton, linen or wooden flours as a filler, materials composed of phenolic, mercury or mercuric compounds shall not be used.

* Materials shall not sustain combustion when burned.

3.4.10 Fungus-resistant and moisture-resistant materials. Materials which are not nutrients for fungi and which are moisture resistant shall be used.

3.4.11 Collector rings. Collector rings, when required, shall be of gold alloy material.

3.4.12 Ball bearings. Ball bearings of the radial thrust type shall conform to MIL-B-81793, tolerance ABEC-5P or better. Double shielding shall be employed where space permits. Balls, races, retainers and shields shall be made of corrosion-resistant steel and shall be in accordance with MIL-B-81793.

MIL-S-81963B

3.4.13 Lubricants. Lubricants used in servocomponents shall be consistent with the requirements herein in regard to fungus and moisture * resistance, corrosion, emission of toxic fumes, and the ability to withstand prolonged storage while enabling the servocomponent to meet all the performance and environmental requirements of this specification.

3.4.14 Threaded parts. All screw threads and tapped holes used in the construction of servocomponents shall be in accordance with FED-STD-H28/2. The number of threads and dimensions shall be those specified for Unified Inch Screw Threads. Unified coarse threads are preferred, except where definite improvements in design or operating characteristics would be affected by use of Unified fine threads. Servocomponents shall be supplied complete with associated terminal screws and washers, and drive nut and washer, as appropriate.

3.4.15 Soldering. Soldering shall be in accordance with Requirement 5 of MIL-STD-454.

3.4.16 Magnet wire. Magnet wire shall conform to J-W-1177, Class 130 or higher.

3.5 Design and construction.

3.5.1 Termination identification. Winding terminations shall be as specified in the applicable specification sheet. (The identification of terminal screw, solder pin or wire lead types shall be as specified in the applicable general specification.) Terminal identification markings shall be molded permanently into the servocomponent end cap. The design of the end cap shall be such that the material in the terminal recess is below the surface of the female-threaded post. All unused terminal positions should be closed or filled. When thread type terminations are specified, the design of the end cap shall be such that the terminal block shall remain fixed when terminal screws are removed.

3.5.2 Servocomponent zero marking. The servocomponent housing shall be permanently marked with an index line or arrow adjacent to the rotor shaft to coincide with a permanent mark on the rotor shaft within 10° of exact servocomponent zero as indicated in the applicable general * specification outline drawing.

* 3.5.3 Dimensions. All dimensions and tolerances of this specification and the applicable general specification shall be in accordance with the latest issue of ANSI Y-14.5M.

3.6 Performance.

3.6.1 Visual and mechanical examination. The servocomponent shall meet the applicable requirements specified for materials, design, construction, physical dimensions, marking and workmanship.

3.6.2 Shaft radial and end play. With a mechanical load on the rotor shaft as specified in the applicable specification sheet, the servo-

MIL-S-81963B

component shall meet the shaft radial and end play limits specified therein.

- * 3.6.3 Shaft runout. When required by the applicable general specification, the shaft runout shall not exceed the specified value of the applicable specification sheet.

3.6.4 Rotor moment of inertia. When required by the applicable general specification, the moment of inertia of the rotor shall be no greater than that specified in the applicable specification sheet.

3.6.5 Breakaway torque.

3.6.5.1 Mechanical breakaway torque. When required by the applicable general specification, the torque required to turn the rotor shall not exceed the values specified in the applicable specification sheet.

3.6.5.2 Electrical breakaway torque. When required by the applicable general specification, the electrical breakaway torque shall not exceed the values specified in the applicable specification sheet.

3.6.6 Dielectric withstanding voltage. The servocomponent shall withstand the test potentials between application points specified in the applicable general specification. The servocomponent shall display no evidence of insulation breakdown or of internal arcing nor shall winding leakage current exceed 1 milliampere peak. The leakage current limit shall not include the current drawn by the test equipment capacitance. Immediately after meeting this requirement, the servocomponent shall meet the insulation resistance requirement.

3.6.7 Insulation resistance. The insulation resistance shall be tested at the DC voltage specified and between the application points designated for dielectric withstanding voltage specified in the applicable general specification. Insulation resistance shall be at least 50 megohms at -55°C or at the standard test condition and at least 10 megohms at the high ambient temperature specified in the applicable general specification.

3.6.8 Current. The current drawn by each winding designated in the applicable general specification shall be within the limits specified in the applicable specification sheet.

3.6.9 Power. The power consumed by each winding designated in the applicable general specification shall be within the limits specified in the applicable specification sheet.

3.6.10 Impedance. The impedance of each winding designated in the applicable general specification shall be within the limits specified therein.

3.6.11 Temperature rise. The temperature rise of the servocomponent shall not exceed the value specified in the applicable specification sheet.

MIL-S-81963B

3.6.12 Variation of brush contact resistance. When required by the applicable general specification, the change of brush contact resistance over the entire length of travel of the brush on the collector rings shall not be more than 1.0 ohm for servocomponents whose measured rotor resistance is 200 ohms or less. Change of brush resistance shall be no more than 0.5 percent of measured rotor resistance for servocomponents whose measured rotor resistance is greater than 200 ohms. Resistance variations of less than 25 milliseconds in duration shall be disregarded.

3.6.13 Electromagnetic interference. When required by the applicable general specification, the servocomponent shall not exceed the conducted and radiated limits of MIL-STD-461, requirements CE03 and RE02 of Equipment Class IIB.

3.6.14 Security of terminals or wire leads.

- * 3.6.14.1 Wire leads. Each wire lead terminal shall conform to the requirements specified in the applicable general specification. Unless specified otherwise in the applicable general specification, each wire lead shall be capable, once only, of withstanding a pulling force of one pound in the case of servocomponent size 05, or of two pounds for servocomponents in frame size 08 and larger. Both conductor strands and insulation shall be subjected to the force. Wire leads shall be anchored so as not to transmit the strain to the internal electrical connections. Following the test, each wire lead shall not separate from the housing nor show evidence of insulation or conductor strand damage. Test in accordance with 4.9.14.1.
- * 3.6.14.2 Screw-thread terminals. Each screw-thread type terminal shall withstand, once only, a gradual torque of 4.5 pound-inches or a 5-pound pressing or pulling force which shall be maintained for a period of 5 to 10 seconds without evidence of movement or damage to the terminal or surrounding materials. Test in accordance with 4.9.14.2.
- * 3.6.14.3 Solder-pin terminals. Each solder-pin type terminal shall withstand, only once, a gradual 2-pound pulling force which shall be maintained for a period of 5 to 10 seconds without evidence of movement or damage to the terminal or surrounding materials. Test in accordance with 4.9.14.3.

3.7 Environmental.

3.7.1 Vibration. Servocomponents of frame size 23 and smaller shall withstand harmonic vibrations of 0.06 inch double amplitude (maximum total excursion) or 15g (pK), whichever is less, over the frequency range of 10 to 2000 Hz in each of three mutually perpendicular planes, one of which shall be that of the servocomponent's shaft axis for a period of four hours in each plane. The vibration cycle of 10 Hz to 2000 Hz, and return to 10 Hz, shall be traversed in 20 minutes. Servocomponents larger than frame size 23 shall withstand harmonic vibrations at frequencies up to 500 Hz at an acceleration of 10g (pK). Unless otherwise specified in the applicable general specification, while in this environment, the servocomponent shall

MIL-S-81963B

be energized and its shaft mechanically loaded in accordance with Figure * 1A or 1B and free to rotate. Subsequently, the servocomponent shall show no evidence of loose or damaged parts and shall then meet the requirements as specified in the applicable general specification.

3.7.2 Shock.

3.7.2.1 Shock, specified pulse. The servocomponent shall withstand 30 impacts at an acceleration of 50g (pK) of 11 \pm 1 millisecond time duration, half sine waveform. The servocomponent shall be subjected to five blows in each direction along three mutually perpendicular axes, one of which shall be that of the servocomponent's shaft axis for a total of 30 blows. Unless otherwise specified in the applicable general specification, while in this environment, the servocomponent shall be energized and its shaft mechanically loaded in accordance with Figure 1 and free to rotate. Subsequently, the servocomponent shall show no evidence of loose or damaged parts and shall then meet the requirements of the applicable general specification.

3.7.2.2 Shock, high impact. The servocomponent shall withstand three shock blows from a weight of 400 pounds falling vertically from heights of 1, 3 and 5 feet, respectively, and three end (back) blows from a weight of 400 pounds swinging on a radius of 5 feet and falling from a vertical height of 1, 3 and 5 feet, respectively. Unless otherwise specified in the applicable general specification, while in this environment, the servocomponent shall be energized and the shaft mechanically loaded and free to rotate. Subsequently, the servocomponent shall show no evidence of loose or damaged parts and shall then meet the requirements of the applicable general specification.

3.7.3 Altitude. The servocomponent shall operate from sea level to 100,000 feet in combination with any temperature from -55°C to the high temperature specified in the applicable general specification.

3.7.3.1 Altitude, low temperature. The servocomponent shall withstand a reduced chamber pressure of 8.27 Torr (approximately equivalent to an altitude of 100,000 feet) after stabilization at an ambient temperature of $-55 \pm 2^{\circ}\text{C}$. While still in this specified environment, the servocomponent shall meet the requirements of the applicable general specification.

3.7.3.2 Altitude, high temperature. The servocomponent shall withstand a reduced chamber pressure of 8.27 Torr (approximately equivalent to an altitude of 100,000 feet) after stabilization at a high ambient temperature environment as specified in the applicable general specification. While still in this specified environment, the servocomponent shall meet the requirements of the applicable general specification.

3.7.4 Endurance. Unless otherwise specified in the applicable general specification, the servocomponent shall be energized and either electrically or mechanically loaded, or both, and either driven or non-driven as specified in the applicable general specification, and shall operate or be operated under the applicable conditions specified in 4.10.4.

MIL-S-81963B

Immediately after meeting this requirement, the servocomponent shall meet the requirements specified in the applicable general specification.

3.7.5 Ambient temperature.

3.7.5.1 Ambient low temperature. The servocomponent shall operate at $-55^{\circ} \pm 2^{\circ}\text{C}$ and shall meet the requirements specified in the applicable general specification.

3.7.5.2 Ambient high temperature. The servocomponent shall operate at the high ambient temperature specified in the applicable specification and shall meet the requirements specified therein.

3.7.6 Moisture resistance. The servocomponent shall operate, or while in storage, withstand 10 continuous 24-hour high humidity and temperature combination cycles. After completion of the final 24-hour recovery period, the servocomponent shall meet the requirements as specified in the applicable general specification.

3.7.7 Audible noise, structureborne. When required by the applicable general specification, the structureborne noise generated in the frequency range of 20 Hz to 9,600 Hz, expressed in terms of acceleration dB above a reference acceleration of $0.001 \text{ cm/second}^2$ ($9.82 \times 10^{-5}\text{g}$), shall not exceed the limiting value or values specified in the applicable specification sheet.

3.7.8 Explosion resistance. When required by the applicable general specification, servocomponents shall operate in the presence of an explosive-gaseous mixture with air without causing an explosion.

3.7.9 Salt atmosphere. When required by the applicable general specification, servocomponents shall withstand atmosphere saturated with salt-laden moisture. On completion of the salt atmosphere test, there shall be no visual evidence of corrosive buildup anywhere within the servocomponent nor evidence of destructive deterioration.

3.7.10 Identification marking. Servocomponents shall, as a minimum, be identified by marking conforming to Figure 2 and MIL-STD-130. Markings shall be applied by acid or electric etching, by permanent marking ink or by engraving, and shall be read from the terminal end. Irrespective of the method used, the marking shall be applied directly to the servocomponent housing; i.e., the use of a separate nameplate attached to the housing is not permitted. The markings shall be such as to withstand and to remain legible following the environmental requirements specified herein.

3.8 Workmanship. The servocomponent, including all parts and accessories, shall be manufactured and finished in a thoroughly workmanlike manner. Particular attention shall be paid to neatness and thoroughness of soldering, wiring, marking and plating. All dimensions and tolerances not specified shall be consistent with best engineering conventions. Where dimensions and tolerances affect interchangeability, operation or performance of the servocomponent, they shall be held or limited accordingly.

MIL-S-81963B

All materials shall be sound, of uniform quality and condition, and free from seams, cracks, and other defects which may adversely affect the strength, endurance, or wear of the part. Any material hammered, filed, or treated in any other manner to conceal defects therein shall be subject to immediate rejection.

4. QUALITY ASSURANCE PROVISIONS

4.1 Responsibility for inspection. Unless otherwise specified in the contract or purchase order, the contractor is responsible for the performance of all inspection requirements, examinations and tests as specified herein. Except as otherwise specified in the contract or purchase order, the contractor may use his own or any other facilities suitable for the performance of the inspection requirements specified herein, unless disapproved by the Government. The Government reserves the right to perform any of the inspections set forth in the specification where such inspections are deemed necessary to assure supplies and services conform to prescribed requirements.

* 4.1.1 Responsibility for compliance. All items shall meet all requirements of sections 3 and 5. The inspection set forth in this specification shall become a part of the contractor's overall inspection system or quality program. The absence of any inspection requirements in the specification shall not relieve the contractor of the responsibility for ensuring that all products or supplies submitted to the Government for acceptance comply with all requirements of the contract. Sampling inspection, as part of manufacturing operations, is an acceptable practice to ascertain conformance to requirements; however, this does not authorize submission of known defective material, either indicated or actual, nor does it commit the Government to accept defective material.

4.1.2 Test equipment and inspection facilities. Test equipment and inspection facilities shall be of sufficient accuracy to permit adequate measuring equipment performance appropriate to the tolerances specified for requirements herein and the applicable specification sheet.

4.1.3 Alternate test methods. When required by the contracting activity, unspecified alternate test methods may be performed under the following conditions:

a. The accuracy shall be demonstrated by analysis and calibration.

b. The accuracy shall be demonstrated by subjecting at least 5 percent of the units under test to both of the above methods with associated test data submitted in a report (see 6.3).

4.2 Test conditions.

4.2.1 Standard test conditions. Unless otherwise specified herein, all measurements and tests shall be in accordance with the general requirements section of MIL-STD-202.

MIL-S-81963B

4.2.2 Temperature conditions of servocomponents under test. Unless otherwise specified in the applicable general specification, all servocomponents shall be tested under the following temperature conditions. The condition which will apply to each test will be specified in the applicable general specification.

4.2.2.1 Temperature, stabilized non-operating. The stabilized non-operating temperature is the condition of a servocomponent after it has remained unenergized in an environment of any specified ambient temperature while shielded from stray air currents for a period sufficient for the servocomponent to have attained a stable temperature. This shall be determined by the periodic measurement of the DC resistance of the particular winding specified in the applicable general specification and shall be deemed to have been attained when the resistance of that winding, measured at five-minute intervals, changes by less than one-half percent from the preceding measurement.

4.2.2.2 Temperature, stabilized operating. The stabilized operating temperature is the condition of a servocomponent, mounted on a standard test fixture, in an environment of any specified ambient temperature after the specified test voltages have been applied to the windings required by the applicable general specification for a period sufficient for the servocomponent to have attained a stable temperature. This shall be determined by the periodic measurement of the DC resistance of the particular winding specified in the applicable general specification and shall be deemed to have been attained when the resistance of that winding, measured at five-minute intervals, changes by less than one-half percent from the preceding measurement. The stabilized operating condition may be assumed to be attained after energization as specified for a period of one hour.

4.2.3 Test power supplies, etc. The following requirements for each type of servocomponent shall be specified in the applicable general specification sheet:

- a. Standard test voltage, frequency, waveform and harmonic content.
- b. Phase relationship of the test voltages, where appropriate.
- c. Special test equipment.

4.3 Mounting fixtures. Unless otherwise specified herein or in the applicable general specification, each test shall be conducted with the servocomponent mounted on a standard test fixture. (See Figures 3 or 4 as appropriate.)

4.4 Electrical test load condition. Unless specified herein or in the applicable general specification, the servocomponent under test shall not be electrically loaded .

MIL-S-81963B

4.5 Classification of inspection. The inspection requirements specified herein are classified as follows:

- a. Qualification inspection - the entire process by which products of manufacturers are examined and tested for the purpose of listing on a Qualified Products List.
- b. First article inspection - tests performed on preproduction samples for the purpose of verifying conformance to the operational, functional, and environmental requirements of the specification.
- c. Quality conformance inspection - tests performed on production lots for the purpose of verifying conformance to specifications and acceptance of the product.

4.6 Qualification inspection. Qualification inspection shall be performed in accordance with the applicable general specification at a laboratory approved by the qualifying activity.

4.6.1 Qualification sample. A sample shall consist of six servocomponents of the same type for which approval is requested. The sample or samples submitted for qualification approval shall be representative of normal production. Four servocomponents shall be selected for the qualification approval sample and two shall be held in reserve against need as directed by the qualifying activity.

4.6.2 Qualification inspection routine. The sample shall be subjected to the tests and examinations in Table I by the sample number shown for individual units within the sample. Qualification inspection shall also include any other tests peculiar to that type servocomponent and shall be performed in the sequence listed under the Qualification and Quality Conformance Inspection Table as specified in the applicable general specification.

4.6.3 Assessment of qualification approval test results.

4.6.3.1 Qualification sample failure. A servocomponent shall be regarded as having failed a particular test either if catastrophic physical damage occurs or if the performance of the servocomponent is outside the limits specified in the applicable general specification. The failure of any one servocomponent of the qualification approval sample shall be sufficient cause for withholding qualification.

4.6.3.2 Qualification sample isolated failure. If it is determined by the qualifying activity that a catastrophic failure is considered to be truly isolated in nature, one substituted new servocomponent may be permitted per test sample. This substituted unit must pass all tests to the point of original failure as well as succeeding tests required by the applicable general specification. A second failure shall be cause for rejection of the sample.

MIL-S-81963B

4.6.3.3 Degradation of performance. The environmental tests to which servocomponents are subjected impose upon them conditions representing the extremes of those likely to be encountered in service. Therefore, under qualification inspection, some small degradations of performance may occur which would be unlikely to arise in service and would not impair the performance of the equipment. Allowable minor degradations following environmental tests are as specified in the applicable general specification.

4.6.3.4 Major failures during or following environmental tests. On the occurrence of failures beyond those permitted by the applicable general specification, the qualifying authority may, at its discretion, either reject the qualification application or require the substitution of two additional servocomponents if one servocomponent of the qualification sample fails. The two servocomponents shall be submitted to all applicable tests prior to and including the failed test(s). One of the two units shall then be selected to undergo the remaining tests in place of the unit which originally failed. Failure of a second unit (from either the original four or from the two reserve units) shall, in all cases, be cause for formal rejection of the qualification sample.

4.6.3.5 Qualification approval by analogy. When a manufacturer seeks approval at any one time for two or more types of any one class of servocomponent of the same frame size, he may apply for qualification approval on the basis of group submission subject to approval by the qualifying activity. All four units of each type shall be subjected to the full range of quality conformance tests. The types shall then be grouped in the manner specified in the applicable general specification and a full test sample of four units shall be selected from each group. This test sample shall be subjected to the remaining qualification approval tests (i.e., one sample of four units shall be fully tested as representing each group). Failure of a test sample shall be cause for withholding approval of the group which it represents. Sample substitution shall not be permitted.

4.6.4 Disposition of qualification sample. Servocomponents subjected to qualification inspection shall not be delivered on any contract or order.

4.6.5 Requalification. In order to retain qualification approval, qualification inspection shall be performed every 24 months or as directed by the qualifying activity.

4.7 First article sample inspection. When first article inspection is required by the procuring activity, sample servocomponents shall be subjected to the provisions governing qualification inspection of 4.6, 4.6.1, 4.6.2 and 4.6.4.

4.7.1 First article sample failure. Failure of any servocomponent in any test shall be cause for refusal to grant first article sample approval.

MIL-S-81963B

4.8 Quality conformance inspection. The examination and tests comprising quality conformance inspection are classified as those specified in Table I and any other tests peculiar to the particular servocomponent which are listed in the Qualification and Quality Conformance Inspection Table of the applicable general specification.

4.8.1 Quality conformance inspection sampling. Statistical sampling and inspection shall be in accordance with MIL-STD-105, Table I, general inspection level II and Table II-A, single sampling plans for normal * inspection.

4.8.2 Quality conformance inspection routine. The minimum of inspection to be verified by the government inspector shall be the applicable tests of Table I and the dimensional and visual requirements as indicated on the outline drawing in the applicable specification sheet.

4.8.3 Quality conformance sample failure. In case of failure, the entire lot shall be rejected. The supplier shall withdraw the lot, correct the deficiencies or screen out the defective units by retest, as applicable and resubmit for inspection.

4.9 Test methods and examinations.

4.9.1 Visual and mechanical examination. The servocomponent shall be examined to verify that the materials, design, construction, physical dimensions, marking, and workmanship are in accordance with the applicable requirements of 3.1, 3.4 through 3.4.16, 3.5.1, 3.5.3, 3.7.10 and 3.8.

4.9.2 Shaft radial and end play.

4.9.2.1 Shaft radial play. The servocomponent shall be mounted rigidly with the shaft horizontal. A dial gauge shall be applied to the shaft as close to the bearing face as possible. A load of the value specified in the applicable specification sheet shall be applied perpendicular to the shaft within 0.25 inch of the end of the shaft, and in a horizontal plane, first in one direction and then in the opposite direction. The difference between the two dial gauge readings shall be taken as the shaft radial play. The shaft radial play shall not exceed the allowable shaft radial play specified in accordance with 3.6.2.

4.9.2.2 Shaft end play. The servocomponent shall be mounted rigidly with the shaft horizontal. A dial gauge shall be applied to the end of the shaft. A load of the value specified in the applicable specification sheet shall be applied axially to the shaft, first in one direction and then in the opposite direction. The difference between the two dial gauge readings shall be taken as the shaft end play. The shaft end play shall not exceed the allowable shaft end play specified in accordance with 3.6.2.

* 4.9.3 Shaft runout. The servocomponent housing shall be rigidly mounted. A dial gauge shall be applied to the shaft within 0.125 inch of the bearing face and the shaft rotated. The difference between the extreme indicator readings shall be the shaft runout and shall meet the requirements of 3.6.3.

MIL-S-81963B

4.9.4 Rotor moment of inertia. The rotor moment of inertia shall be measured by one of the following methods and shall not exceed the value specified in the applicable specification sheet.

4.9.4.1 Moment of inertia by torsional oscillations. The rotor of the servocomponent shall be fixed to an adaptor of the lowest possible inertia (which shall be measured or calculated) and the adaptor and rotor shall be suspended from a steel wire at least 10 feet long, so that the axis of the rotor coincides with that of the suspension wire. The suspended mass shall be protected from air currents and extraneous vibrations which may cause it to sway. The adaptor-rotor assembly shall be twisted so that oscillation occurs about the axis of suspension. The period t_a , of the oscillation shall be determined. With the same procedure and adaptor being used, the period, t_b , of a body of known inertia shall then be determined. The moment of inertia of the rotor may then be determined from the expression:

$$J_a = \left[(J_b + J_{ad}) \times \frac{(t_a)^2}{(t_b)^2} - J_{ad} \right]$$

where:

- J_a = moment of inertia of rotor in gram-centimeters²
- J_b = moment of inertia of known body in gram-centimeters²
- J_{ad} = calculated moment of inertia of adaptor in gram-centimeters²
- t_a = period of oscillation of rotor plus adaptor, in seconds
- t_b = period of oscillation of body of known inertia plus adaptor, in seconds

4.9.4.2 Moment of inertia by trifilar suspension. The rotor of the servocomponent shall be placed in a plate (circular disc or equilateral triangle) so that the axis of rotation of the rotor is perpendicular to the plate and in the exact center of the plate. The weight of the plate shall be approximately equal to the weight of the rotor. Three threads of equal length shall be connected to a flat, level mounting surface and the plate shall be attached to the threads. The threads shall be equidistant and parallel to the axis of rotation. The distance between the mounting surface and the plate shall be greater than twice the radius from the axis of rotation to the threads (see Figure 5). The plate shall be protected from air currents and extraneous vibrations, rotated and the time period measured as the plate oscillates through a small angle about the axis of rotation with and without using the following formula:

$$I = \frac{W_r r^2 t^2 + W_b r^2 (t^2 - t_b^2)}{4L}$$

MIL-S-81963B

where:

- I = rotor moment of inertia in gram-centimeters²
- W = weight of rotor in grams
- W_b = weight of plate in grams
- t = time period of oscillation of the plate with rotor -
in seconds
- t_b = time period of oscillation of plate without rotor -
in seconds
- L = distance from the plate to the mounting surface -
in centimeters
- r = radius from the axis of rotation to the threads -
in centimeters

4.9.5 Breakaway torque.

4.9.5.1 Mechanical breakaway torque. With the applicable weight of Figure 6 attached to the dial of Figure 7 (corresponding to the developed torque specified in the applicable specification sheet) and with the dial mounted rigidly on the shaft and hanging free at the start of the test, the housing of the servocomponent shall be rotated through at least three revolutions in each direction at a constant rate between 4 and 6 rpm in accordance with 3.6.5.1. The servocomponent shall fail the test if the dial turns one revolution.

4.9.5.2 Electrical breakaway torque. The servocomponent shall be brought to the stabilized operating temperature condition (as specified in the applicable general specification). With the shaft in any initial angular position, voltage applied to the control winding shall be increased slowly from zero. The voltage at which the shaft starts to rotate continuously shall be noted. The test shall be performed three times for each direction of rotation (a total of six measurements). The highest voltage observed shall be recorded as the electrical breakaway torque, and shall meet the requirements of 3.6.5.2.

4.9.6 Dielectric withstanding voltage. The dielectric withstanding voltage test shall be performed in accordance with Method 301 of MIL-STD-202 and the requirements of 3.6.6. The applicable test potentials shall be applied between those points designated. Any dielectric withstanding voltage test that is repeated on the same servocomponent shall be performed with the test potential reduced to 80 percent of the specified value of the initial test. The test potential shall be raised slowly (minimum time 3 seconds) from zero to the specified value. The peak value of the test potential throughout this test shall not exceed 1.5 times the specified rms test potential. The test equipment employed shall be such as to differentiate between winding leakage current and surge discharge

MIL-S-81963B

current. Following this test, the insulation resistance test shall be performed in accordance with 4.9.7.

4.9.7 Insulation resistance. The insulation resistance shall be measured in accordance with Method 302 of MIL-STD-202 to determine conformance with 3.6.7.

4.9.8 Current. The servocomponent shall be brought to the stabilized operating condition of 4.2.2.2 in the standard test conditions of 4.2.1. The current drawn by each winding shall be measured and shall be in accordance with 3.6.8.

4.9.9 Power. The servocomponent shall be brought to the stabilized operating condition of 4.2.2.2 in the standard test conditions of 4.2.1. The power consumed by each winding shall be measured and shall be in accordance with 3.6.9.

4.9.10 Impedance. The servocomponent shall be brought to the stabilized operating condition of 4.2.2.2 in the standard test conditions of 4.2.1 and while energized at the applicable standard test voltage and frequency specified in the applicable general specification, the impedance of each winding shall be determined and shall be in accordance with 3.6.10.

4.9.10.1 General. Impedance methods of measurements described hereunder are applicable within specified limitations to all types of servocomponents. However, because of the high accuracy attainable with methods described hereunder, measurements lend themselves more to synchros, resolvers, transolvers, and linear resolvers rather than servomotors, where in general, less sophisticated methods are acceptable.

4.9.10.1.1 The Wien-modified Maxwell bridge. Figure 8 shows the circuit diagram of the bridge, together with the appropriate equations necessary for calculating the servocomponent impedances. The following practical points should be noted:

a. The screen connections on the bridge elements should be arranged as shown in Figure 8 so that the capacitance currents to ground are drawn directly from the supply and are not permitted to shunt the elements.

b. The use of a double screen transformer is essential in order to eliminate the effect of stray capacitance and the ground leakage path from the power supply generator or transformer to the ground terminal of the null detector.

c. The resistance of arm R3 should be kept as small as possible in order to minimize frequency variation errors.

d. Magnetic coupling between the power supply transformer and the null detector transformer(s) may cause additional errors. The power supply transformer should be so positioned that, with the bridge in its balanced condition, rotation about its axis causes no significant alteration of null indication.

MIL-S-81963B

e. Careful attention should be paid to accuracy in setting up the voltage and frequency of the supply.

f. If a synchro, resolver, or transolver is under test, it should preferably be set to zero within ± 3 minutes of arc.

g. The accuracy of the bridge components should be within 0.1 percent of the nominal values.

4.9.10.1.2 The Marshall potentiometer. Figure 9 shows the circuit diagram of the potentiometer while Figure 10 shows the current balancing network, together with the formula for determining servocomponent current. It is evident from the figures that the potentiometer depends for its action on the provision of a current which is in phase-opposition to, and is an integral multiple of, the servocomponent current. Under balanced conditions, the servocomponent current is given by the ammeter reading divided by the current division ratio, while the applied voltage is given by the voltmeter reading multiplied by a ratio dependent on the taps of the transformer T1 from which the voltmeter and servocomponent are supplied. The servocomponent impedance may then be calculated from wattmeter, voltmeter and ammeter readings.

a. The method has the advantages that the meter losses do not have to be taken into account and servocomponent current is not a limiting factor, since the current divider should be designed to be of very low resistance so that power dissipation is small. A suitable value for the first tap (divide by one) is 0.5 ohm, as shown in Figure 10.

b. Transformer T1 should be designed so that the maximum possible load does not significantly affect the voltage ratio between the taps, and in use, the tapping points should be chosen to give large deflections on the voltmeter and wattmeter.

4.9.10.1.3 Incremental induction bridge. Figure 11 shows the circuit diagram and the appropriate equations for calculating servocomponent impedance using the incremental induction bridge. The bridge consists of the unknown (winding under test) and resistors R_a , R_b and R_c . The value of R_b shall be small compared to the unknown. The current through the unknown causes a voltage drop across R_b . R_1 is in the circuit to compensate for the voltage drop across R_b . The setting of the inductance (L) balance control causes the L isolation amplifier to create a current, in phase with the generator, to flow in the standard capacitor (C). The resistance (R) balance control, along with the $R_a R_c$ voltage divider and the isolation amplifiers, cause a current to flow in the standard resistor (G), that is proportional but opposite in phase to the generator voltage. The combination of the L current and the R current is adjusted to create a null on the detector. The resistance and inductance can then be read directly from the dials on the balance control and used to calculate the impedance as shown in Figure 11.

MIL-S-81963B

4.9.11 Temperature rise. The servocomponent, mounted on the appropriate standard test fixture, shall be placed in a chamber, the volume of which shall allow between three and five cubic feet of free air space per servocomponent. Servomotors and motor-generators shall have the shaft locked in such a manner that it cannot rotate. The internal ambient temperature of the chamber shall be adjusted to a value within the range $23 \pm 2^\circ\text{C}$. This value shall be recorded and shall be maintained throughout the test. The DC resistance of that winding designated in the applicable general specification shall be measured and recorded when the servocomponent has attained the stabilized non-operating condition of 4.2.2.1. All windings specified in the applicable general specification shall then be energized at the standard rated voltage and frequency as specified in the applicable general specification and the DC resistance of the designated winding shall be measured when the servocomponent has attained the stabilized operating condition of 4.2.2.2. The methods used for measuring the DC resistance of the designated winding shall not entail disconnection of that winding from the energizing supply while the measurements are taken. (Figure 12 shows a suitable circuit for this purpose.) The temperature rise calculated from the expression which follows shall be in accordance with 3.6.11.

$$* \quad \text{Temperature rise, } (^\circ\text{C}) = \frac{R_h - R_c}{R_c} \times (234.5 + t_c)$$

where:

R_h = resistance of the designated winding at the final stabilized temperature

R_c = resistance of the designated winding at the starting temperature

t_c = starting temperature

234.5 = $1/0.00427$ (0.00427 is the temperature coefficient of resistance of 100 percent conductivity IACS - International Annealed Copper Standard - copper at 0°C).

4.9.12 Variation of brush contact resistance. The servocomponent shall be energized from a source of constant current not to exceed 10 milliamperes and the brush contact resistance variation between collector rings and brushes as exhibited by a change in voltage between each set of rotor winding terminals shall be measured. The rotor shall be turned at one rpm and after the third revolution, the measurement shall be performed through a complete revolution. The variation of brush contact resistance shall be in accordance with 3.6.12. For qualification approval, the variation of brush contact resistance shall be determined by the method described in 4.9.12.1.

4.9.12.1 Method of measurement for variation of brush contact resistance. Figure 13 is a basic bridge circuit. Example shown is for synchro transmitters, receivers, and control transformers. R_1 resistor is adjusted to approximately twice the value of the DC rotor resistance. R_4

MIL-S-81963B

resistor is set to 0.5 ohms and will be used for setting the limits on the recorder. R_2 and R_3 resistors are used to balance the bridge. A maximum of 10 mA through the rotor winding is recommended unless the applicable specification sheet specifies a lower current value. Balancing the bridge is accomplished by using R_2 and R_3 resistors with a suitable amplification factor set on the DC amplifier and the center scale DC meter. The sensitivity of both instruments is increased as the bridge is being balanced in order to produce a good null. If excessive drifting occurs, the rotor current should be reduced until a steady null is achieved. The sensitivity of the recorder and amplifier are now set at a level that will give a good reference on the tape when the resistance of R_4 is decreased and increased from the 0.5 ohm setting (0.0 to 1.0). After the reference marks have been established on the tape, the rotor is turned by the one rpm motor with the recorder chart feed set at 5 mm per second.

4.9.13 Electromagnetic interference. When required by the applicable general specification, the servocomponent shall be tested for conducted and radiated electromagnetic interference in accordance with MIL-STD-462 while energized at the standard test voltage on those windings specified in the applicable general specification and under the conditions of electrical or mechanical load also specified therein. The conducted and radiated electromagnetic interference shall not exceed the limits as specified in 3.6.13.

4.9.14 Security of terminals or wire leads.

4.9.14.1 Wire leads. The force shall be applied at the extreme end of the lead and in a downward direction while the servocomponent is held with its shaft vertically upward in the case of servocomponents having leads emerging from the back end of the servocomponent, or while the servocomponent is held with its shaft horizontal in the case of servocomponents having leads emerging from the housing periphery. In the latter case, the servocomponent shall be so held that the lead exit is on the under side. For end-emergent leads, the servocomponent shall then be turned through an angle of 90 degrees so that the shaft axis is horizontal. While in this position, the housing shall be rotated once in each direction, clockwise and counterclockwise, about the shaft axis through an angle of 360 degrees. For side-emergent leads, the servocomponent shall then be turned through an angle of 90 degrees so that the shaft is vertically upward. While in this position, the housing shall be turned once in each direction, clockwise and counterclockwise about the axis of emergence of the leads (that is, end over end), through an angle of 360 degrees. The method of applying force shall be such that the latter is borne by both the conductor strands and the insulation. Wire lead strength shall be in accordance with 3.6.14.1 (see Figure 14).

* 4.9.14.2 Screw-thread terminals. Each screw-thread terminal shall be tested by means of a 5-pound spring scale or dead weight applying force inward toward the housing and outward from the housing. Each terminal shall then be subjected to a torque of 4.5 lb-in by means of a device such as a torque wrench or torque watch, which applies only torque and not force. The torque shall be applied clockwise about the centerline of the

MIL-S-81963B

terminal assembly. The specified load shall be increased gradually at a rate not to exceed one pound per second. Screw-thread terminal strength shall be in accordance with 3.6.14.2.

- * 4.9.14.3 Solder-pin terminals. Each solder-pin terminal shall be tested using a two-pound pulling force applied gradually in a direction parallel with the shaft axis and outward from the housing. The force shall be applied once only in each direction specified and shall be maintained for a period of 5 to 10 seconds. Solder-pin terminal strength shall be in accordance with 3.6.14.3.

4.10 Environmental.

4.10.1 Vibration. Servocomponents shall be tested in accordance with MIL-STD-202, Method 204. Servocomponents larger than size 23 shall be tested in accordance with requirements of Test Condition A, and servocomponents size 23 and smaller shall be tested in accordance with the requirements of Test Condition B. Throughout the test, the servocomponent shall be rigidly mounted on a test fixture, utilizing standard mounting surfaces, shall be energized and its shaft mechanically loaded and free to rotate as specified in the applicable general specification. Servocomponents shall have an aluminum disc conforming to Figure 1 securely mounted on the shaft utilizing standard hardware. After completion of this test, the servocomponent shall meet the requirements of 3.7.1.

4.10.2 Shock.

- 4.10.2.1 Shock, specified pulse. Servocomponents shall be tested in accordance with MIL-STD-202, Method 213, Test Condition A. The servocomponent shall be securely clamped to a rigid test fixture utilizing normal mounting surfaces which shall be rigidly mounted on the test device. During the test, the servocomponent shall have the shaft loaded with the appropriate disc of Figure 1, or shall be unloaded as called for by the applicable general specification. The servocomponent shall be energized as designated in the general specification. The rotor shall be mechanically free to rotate or not, also as indicated in the applicable general specification. After completion of this test, the servocomponent shall meet the requirements specified in 3.7.2.1.

- * 4.10.2.2 Shock, high impact. Servocomponents shall be tested in accordance with MIL-STD-202, Method 207 and shall be rigidly mounted to the equipment of Figure 207-4A therein, utilizing normal mounting surfaces. The servocomponent shall have the shaft loaded with the appropriate disc of Figure 1, or shall be unloaded as called for by the applicable general specification. The servocomponent shall be energized as designated in the applicable general specification. After completion of this test, the servocomponent shall meet the requirements specified in 3.7.2.2.

4.10.3 Altitude.

4.10.3.1 Altitude, low temperature. The unenergized servocomponent shall be placed in a test chamber, the internal ambient temperature of

MIL-S-81963B

which shall be reduced to and controlled at $-55 \pm 2^\circ\text{C}$ and the servocomponent shall be allowed to attain the stabilized non-operating temperature condition of 4.2.2.1. The servocomponent shall then be energized so as to attain the stabilized operating temperature condition of 4.2.2.2. The pressure in the test chamber shall then be reduced to 8.27 Torr (approximately equivalent to an altitude of 100,000 feet). While still in this specified environment, the servocomponent shall be subjected to and shall meet the requirements as specified in 3.7.3.1.

4.10.3.2 Altitude, high temperature. The unenergized servocomponent shall be placed in a test chamber, the internal ambient temperature of which shall be raised to and controlled within $\pm 2^\circ\text{C}$ of the high ambient temperature specified in the applicable general specification and the servocomponent shall be allowed to attain the stabilized non-operating temperature condition of 4.2.2.1. The servocomponent shall then be energized so as to attain the stabilized operating temperature condition of 4.2.2.2. The pressure in the test chamber shall then be reduced to 8.27 Torr (approximately equivalent to an altitude of 100,000 feet). While still in this specified environment, the servocomponent shall be subjected to and shall meet the requirements as specified in 3.7.3.2.

4.10.4 Endurance. Unless otherwise specified in the applicable general specification, the servocomponent shall be energized and either electrically or mechanically loaded or both and either driven or non-driven as specified in the applicable general specification and shall operate or be operated under the applicable condition shown in Table II. On completion of the endurance test the servocomponent shall be subjected to and shall meet the requirements specified in 3.7.4.

4.10.5 Ambient temperature.

4.10.5.1 Ambient low temperature. The unenergized servocomponent shall be placed in a test chamber and mounted on a test fixture. The chamber temperature shall be lowered to and maintained at $-62^\circ \pm 2^\circ\text{C}$. The servocomponent shall be allowed to attain the stabilized non-operating temperature condition of 4.2.2.1 while in this environment. The test chamber temperature shall then be raised to and controlled at $-55^\circ \pm 2^\circ\text{C}$ for a period of one hour. At the end of this period and while in this * environment, unless specified otherwise in the applicable specification, the unit shall be energized in accordance with 4.2.3 and allowed to attain the stabilized operating temperature condition of 4.2.2.2. The servocomponent shall then meet the requirements specified in 3.7.5.1.

4.10.5.2 Ambient high temperature. The unenergized servocomponent shall be placed in a test chamber and mounted on a test fixture. The chamber temperature shall be raised to and maintained within $\pm 2^\circ\text{C}$ of the high ambient temperature specified in the applicable general specification. The servocomponent shall then be allowed to attain the stabilized non- * operating temperature condition of 4.2.2.1. Unless specified otherwise in the applicable general specification, the servocomponent shall be energized in accordance with 4.2.3 and allowed to attain the stabilized operating temperature condition of 4.2.2.2. The servocomponent shall then meet the requirements specified in 3.7.5.2.

MIL-S-81963B

4.10.6 Moisture resistance. The servocomponent shall be tested in accordance with MIL-STD-202, Method 106 and the requirements of 3.7.6. The servocomponent shall be placed in the test chamber with its rotor shaft in a horizontal position. During the test, half of the qualification sample (one servocomponent) shall be energized in accordance with 4.2.3 and the other half shall be unenergized. Unless specified otherwise in the applicable general specification, after completion of the final cycle, the entire sample (two servocomponents) shall be maintained energized at standard test conditions (see 4.2.1) for 24 \pm 4 hours. Immediately after the final energization period, the servocomponent shall be subjected to and meet the requirements as specified in 3.7.6.

4.10.7 Audible noise, structureborne. When specified in the applicable specification sheet, the servocomponent shall be mounted on the noise test fixture shown in Figure 15, unless specified otherwise in the applicable general specification, by means of the appropriate standard mounting clamps. A calibrated accelerometer shall be fitted to the mounting plate successively in each of the positions shown in Figure 16. The surfaces of the accelerometer and its attachment area shall be coated lightly with a suitable grease. The accelerometer shall be attached to the mounting plate with a 10-32UNF-2A stud or bolt whose threads shall be coated with a suitable grease engaged at least 0.25-inch deep in the tapped hole in the plate. The torque used in the method of attaching the accelerometer to the plate shall be as recommended by accelerometer manufacturers. The fixture, complete with servocomponent, shall be suspended as shown in Figure 16 in such a manner that the shaft axis and the top edge of the mounting plate are horizontal to within 5 degrees. With the servocomponent unenergized, the prevailing ambient noise level for the broad, one-third octave and narrow bands shall be at least 14 dB below the specified maximum noise limit for the servocomponent in that band or at that frequency. Those windings designated in the applicable general specification shall then be energized as specified therein and the vibration level of the servocomponent shall be determined and be recorded for each frequency band. Unless otherwise specified, the one-third octave and narrow band measurements shall be conducted in that axis of the servocomponent for which the maximum broadband vibration level is recorded. The structureborne noise generated in the frequency range of 20 Hz to 9,600 Hz, expressed in terms of acceleration dB above a reference acceleration of 0.001 cm/second² (9.8×10^{-5} g) shall not exceed the limiting value or values specified in the applicable specification sheet. Broadband structureborne noise, expressed in terms of acceleration dB, shall be measured by means of a calibrated transducer and vibration-level meter which, including cables and accessories, have a frequency response known to within ± 2 dB over the frequency range of 20 Hz to 9,600 Hz. The equipment used shall possess a low response to magnetic, electrical and acoustic fields. No correction for extraneous response shall be permitted in determining the structureborne noise level of a servocomponent. The response of the equipment to extraneous fields shall be at least 14 dB below the maximum noise limits specified for the servocomponent in the applicable specification sheet. One-third octave band structureborne noise shall be measured with the same equipment that is used for the broadband

MIL-S-81963B

noise measurements but with the addition of one-third band filters covering the range 20 Hz to 8,000 Hz. The filters shall have rejection characteristics beyond the band edges at least as good as those required by MIL-STD-740(SH) and ANSI-S1.11 for octave band filters. The complete system, including cables and accessories, shall have a response known to within ± 2 dB at all band centers within the range. The scanning rate used for the test shall be not less than 5 seconds per band. Narrow-band structureborne noise shall be measured with the same equipment as is used for the broadband noise measurement but with the addition of a vibration-level recorder and a narrow-band analyzer capable of being turned continuously or of being swept through band-center frequencies from 20 Hz to 9,600 Hz. The complete system, including cables and accessories, shall have a response known to within ± 2 dB at all band-center frequencies in the range. The scanning or sweeping rate used for the test shall not exceed (one-half \times filter width in Hz²) 200 Hz per second. The servocomponent shall meet the requirements as specified in 3.7.7.

4.10.8 Explosion resistance. For certain specialized requirements, servocomponents may be called upon to operate in flammable atmospheres. In view of their light form of construction, the servocomponents cannot be made intrinsically explosion-proof, nor can it be ensured, unless size and weight penalties be accepted, that even a servocomponent devoid of moving electrical contacts will be intrinsically safe since its operating surface temperature may well exceed the ignition temperature of the flammable atmosphere. Testing for either 200 or 2,000 hours, dependent upon the degree of acceptable risk and on the nature of the atmosphere, is needed to ascertain the explosion characteristics of a servocomponent. Accordingly, and in view of the probable low incidence of requirements for explosion-proof servocomponents, no test for such characteristics is specified in this document. Should a requirement arise, it will be the responsibility of the qualifying activity concerned to specify the explosion tests to be performed on a servocomponent to satisfy its requirements. It is recommended, however, that if such a test is invoked, it should be applied to servocomponents which have completed all qualification approval tests other than salt atmosphere, if appropriate, so that the condition of the test servocomponents will approximate that which is typical after a considerable period of service. The servocomponent shall meet the requirements specified in 3.7.8.

4.10.9 Salt atmosphere. Servocomponents shall be tested in accordance with MIL-STD-202, Method 101, Test Condition B, with a 5 percent salt solution. The servocomponent shall be placed in the test chamber with its shaft horizontal and supported in a manner that provides line contact on material impervious to the effects of salt moisture and permit maximum circulation of the atmosphere about the servocomponent. After completion of the test, the servocomponent shall meet the requirements specified in 3.7.9.

4.11 Inspection of packaging. Sample packages and packs shall be selected and inspected in accordance with MIL-S-12134.

MIL-S-81963B

5. PACKAGING

5.1 Packaging and packing. Packaging shall conform to MIL-S-12134. Minimum packing shall be level C, unless specified otherwise on the contract (see 6.2e).

6. NOTES

(This section contains information of a general or explanatory nature that may be helpful, but is not mandatory.)

6.1 Intended use. Servocomponents covered by this specification are intended for use in military systems for fire control, radar, navigation, guided missiles, and other precision applications.

6.2 Acquisition requirements. Acquisition documents should specify the following:

- a. Title, number, and date of this specification
- b. Title, number, and date of the applicable general specification
- c. Title, number, and date of the applicable specification sheet, the complete nomenclature, and the military part number
- d. Issue of the DODISS to be cited in the solicitation, and if required, the specific issue of individual documents referenced (see 2.1)
- e. Whether first article inspection is required (3.3)
- f. Level of packaging and packing, if other than Level C (specified in 5.1)

6.3 Consideration of data requirements. The following data requirements should be considered when this specification is applied on a contract. The applicable Data Item Descriptions (DID's) should be reviewed in conjunction with the specific acquisition to ensure that only essential data are requested/provided and that the DID's are tailored to reflect the requirements of the specific acquisition. To ensure correct contractual application of the data requirements, a Contract Data Requirements List (DD Form 1423) must be prepared to obtain the data, except where DOD FAR Supplement 27.475-1 exempts the requirement for a DD Form 1423.

<u>Reference Paragraph</u>	<u>DID Number</u>	<u>DID Title</u>	<u>Suggested Tailoring</u>
4.1.3	DI-5247	Test Reports	Use contractor format

MIL-S-81963B

6.4 First article inspection. When first article inspection is required, information pertaining to the products covered by this specification should be obtained from the contracting activity for the * specific contracts involved. Invitations for bids should provide that the Government reserves the right to waive the requirement for samples for first article inspection to those bidders offering a product which has been previously acquired or tested by the Government, and that bidders offering such products, who wish to rely on such production or test, must furnish evidence with the bid that prior Government approval is presently appropriate for the pending contract. Bidders should not submit alternate bids unless specifically requested to do so in the solicitation.

6.5 Definitions. Definitions are explained in the applicable general specification.

6.6 Relationship with servocomponent class specifications. This * specification consolidates requirements and tests common to nine existing analog and digital and analog/digital precision instrument rotating servocomponent specifications and has been issued for two express purposes:

a. Elimination of multiple revisions or amendments to effect the same changes in individual servocomponent class specifications for the primary purpose of updating those requirements and tests necessary to align them with other servocomponent class specifications.

b. Provide more meaningful Government and industry participation by highlighting specific design, test, and environmental criteria of the latest engineering developments that are common to the following specifications:

MIL-S-20708	Synchros, General Specification for
MIL-S-22432	Servomotor, General Specification for
MIL-S-22820	Servomotor-Tachometer Generator AC, General Specification for
MIL-T-22821	Tachometer Generator AC, General Specification for
MIL-R-23417	Resolver, Electrical, General Specification for
MIL-R-50781	Resolvers, Electrical, Linear: General Specification for
MIL-E-81512	Encoder, Shaft Position to Digital, Contact Type, Altitude Reporting, General Specification for
* MIL-S-81746	Servtorqs, General Specification for
MIL-T-83727	Transolver, General Specification for

* 6.7. Subject term (key word) listing.

Bearings
Encoders
Dielectric withstanding voltage
Electrolytic corrosion
First article

MIL-S-81963B

Impedance
 Insulation resistance
 Qualification
 Qualified Products List (QPL)
 Quality conformance
 Resolvers
 Servomotor-tachometer generator
 Servomotors
 Servitors
 Specification sheets
 Synchros
 Tachometer generators
 Transolvers

- * **6.8 Changes from previous issue.** The margins of this specification are marked with asterisks to indicate where changes (additions, modifications, corrections, deletions) from the previous issue were made. This was done as a convenience only and the Government assumes no liability whatsoever for any inaccuracies in these notations. Bidders and contractors are cautioned to evaluate the requirements of this document based on the entire content, irrespective of the marginal notations and relationship to the last previous issue.

- * **6.9 International standardization agreements.** Certain provisions of this specification are the subject of international standardization agreement reached by the NATO Working Group on Analogue and Digital Servocomponents (AC/301(SG/A)(WG/5)). When amendment, revision, or cancellation of this specification is proposed which affects or violates the international agreement concerned, the preparing activity will take appropriate reconciliation action through international standardization channels including departmental standardization offices, if required.

- * **6.10 Applicable international documentation.** NATO documents applicable to this specification are Allied Standard Publication (ASTanP)-4, Volume 5990 Chapter 3, NATO Electronic/Electrical Technical Recommendation, General Requirements and Common Tests; and ASTanP-5, Volume 5990 Chapter 3, NATO Quality Assessment Recommendation for Electronic/Electrical Parts, General Requirements and Common Tests.

6.11 Qualification. With respect to products requiring qualification, awards will be made only for products which are, at the time set for opening of bids, qualified for inclusion in the applicable Qualified Products List whether or not such products have actually been so listed by that date. The attention of the suppliers is called to this requirement, and manufacturers are urged to arrange to have the products they propose to offer to the Federal Government tested for qualification in order that they may be eligible to be awarded contracts or orders for the products covered by this specification. The activity responsible for the Qualified Products List and information pertaining to qualification of products are listed in the applicable general specification.

MIL-S-81963B

TABLE I. Qualification and quality conformance inspection tests.

Test No.	Requirement	Test	Test method for examination	Inspection	
				Qualification Sample Number	Quality Conformance
1	3.6.1	4.9.1	Visual and mechanical inspection	1, 2, 3, 4	X
2	3.6.2	4.9.2	Shaft radial and end play	1, 2, 3, 4	X
3	3.6.3	4.9.3	Total shaft runout (smooth portion)	1, 2, 3, 4	X
4	3.6.4	4.9.4	Rotor moment of inertia I /	1, 2, 3, 4	-
5	3.6.5.1	4.9.5.1	Mechanical breakaway torque	1, 2, 3, 4	X
6	3.6.5.2	4.9.6.2	Electrical breakaway torque (starting voltage)	1, 2, 3, 4	X
7	3.6.6	4.9.6	Dielectric withstanding voltage	1, 2, 3, 4	X
8	3.6.7	4.9.7	Insulation resistance	1, 2, 3, 4	X
9	3.6.8	4.9.8	Current	1, 2, 3, 4	X
10	3.6.9	4.9.9	Power	1, 2, 3, 4	X
11	3.6.10	4.9.10	Impedance	1, 2, 3, 4	-
12	3.6.11	4.9.11	Temperature rise	1, 2, 3, 4	-
13	3.6.12	4.9.12	Variation of brush contact resistance I /	1, 2, 3, 4	X
14	3.6.13	4.9.13	Electromagnetic interference I /	1, 2, 3, 4	-

MIL-S-81963B

TABLE I. Qualification and quality conformance inspection tests - (Continued).

Test No.	Requirement	Test	Test method for examination	Inspection	
				Qualification Sample Number	Quality Conformance
15	3.6.14	4.9.14	Security of terminals/wire leads	1, 2, 3, 4	-
16	3.7.1	4.10.1	Vibration	1, 2, 3, 4	-
17	3.7.2.1	4.10.2.1	Shock, specified pulse	1, 2, 3, 4	-
18	3.7.3.1	4.10.3.1	Altitude, low temperature	1, 2	-
19	3.7.3.2	4.10.3.2	Altitude, high temperature	1, 2	-
20	3.7.4	4.10.4	Endurance	1, 2	-
21	3.7.5.1	4.10.5.1	Ambient low temperature	3, 4	-
22	3.7.5.2	4.10.5.2	Ambient high temperature	3, 4	-
23	3.7.6	4.10.6	Moisture resistance	3, 4	-
24	3.7.2.2	4.10.2.2	Shock, high impact	1, 2, 3, 4	-
25	3.7.7	4.10.7	Audible noise structureborne ^{1/}	1, 2, 3, 4	-
26	3.7.8	4.10.8	Salt atmosphere ^{1/}	1, 2	-
27	3.7.9	4.10.9	Explosion resistance ^{1/}	1, 2	-

^{1/}These tests are special and shall be performed only when required in the applicable general specification.

MIL-S-81963B

TABLE II. Endurance test time schedule.

SPECIFICATION NUMBER				Shaft Position
MIL-S-22432 MIL-S-22820 MIL-T-22821		MIL-S-20708 MIL-R-23417 MIL-R-50781 MIL-T-83727		
Time <u>1</u> / (Hours)	Temperature °C	Time <u>1</u> / (Hours)	Temperature °C	
64 ± 2	-55 ± 5	64 ± 2	-25 ± 5°	Horizontal
24 ± 2	H <u>2</u> /	24 ± 2	H <u>2</u> /	Vertically Upward
24 ± 2	H <u>2</u> /	24 ± 2	H <u>2</u> /	45° Upward
24 ± 2	H <u>2</u> /	24 ± 2	H <u>2</u> /	45° Downward
24 ± 2	H <u>2</u> /	24 ± 2	H <u>2</u>	Vertically Downward
740 ± 4	15° to 30° (see 4.2.1)	1840 ± 4	15° to 30° (see 4.2.1)	Horizontal
100 ± 3	<u>3</u> / 100 ± 5°			Horizontal

NOTES:

1/ 50 percent of rotation to be CW and 50 percent of rotation to be CCW.

2/ H is the ambient temperature specified in the applicable general specification.

3/ For MIL-S-22432 and MIL-S-22820, the 100 hrs at 100°C portion of the test shall be performed at maximum power output, as specified in MIL-S-22432 and MIL-S-22820.

MIL-S-81963B

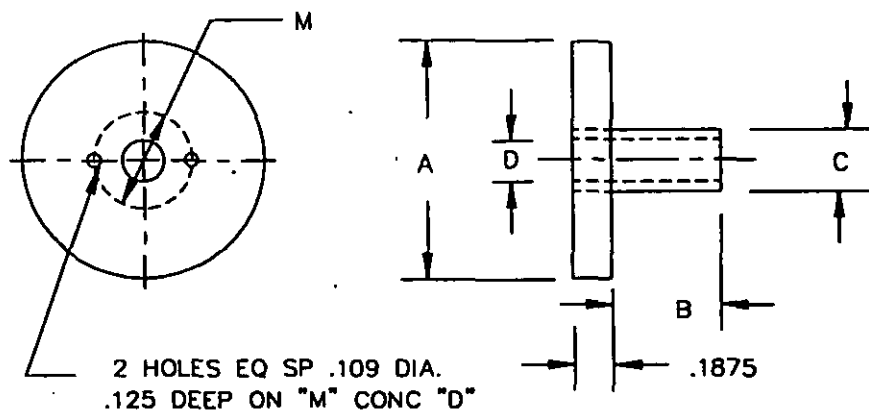

SERVO-COMPONENT SIZE	DIMENSIONS				
	A	B	C	D	M*
	INCH	INCH	INCH	INCH	INCH
11, 15, 18	2.0	.1875	.26	.1875	.375
23	2.0	.3125	.60	.2410	.437
31, 37	2.7, 3.3	.3125	.60	.2410	.437

* FOR MOUNTING WITH STANDARD DRIVE WASHER

FIGURE 1A. Standard disc for loading size 11, 15, 18, 23, 31, and 37 servocomponent shaft.

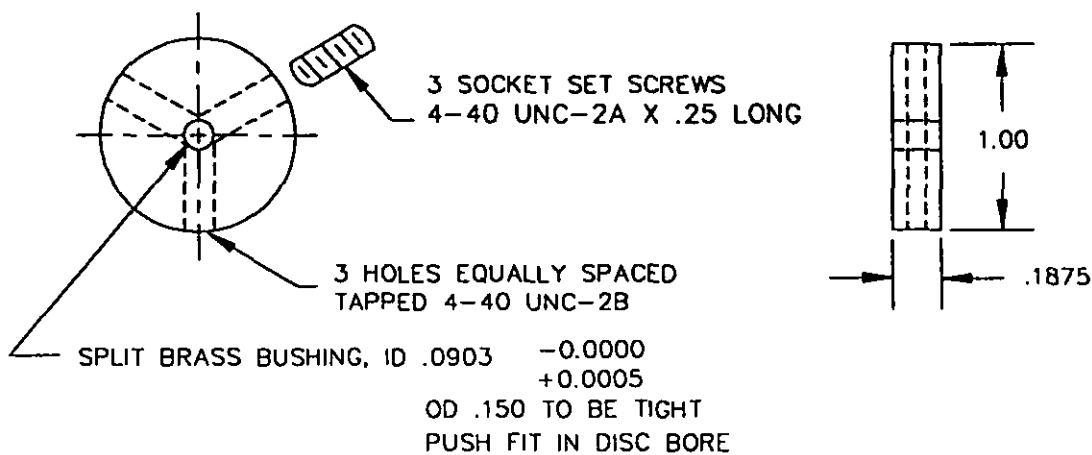
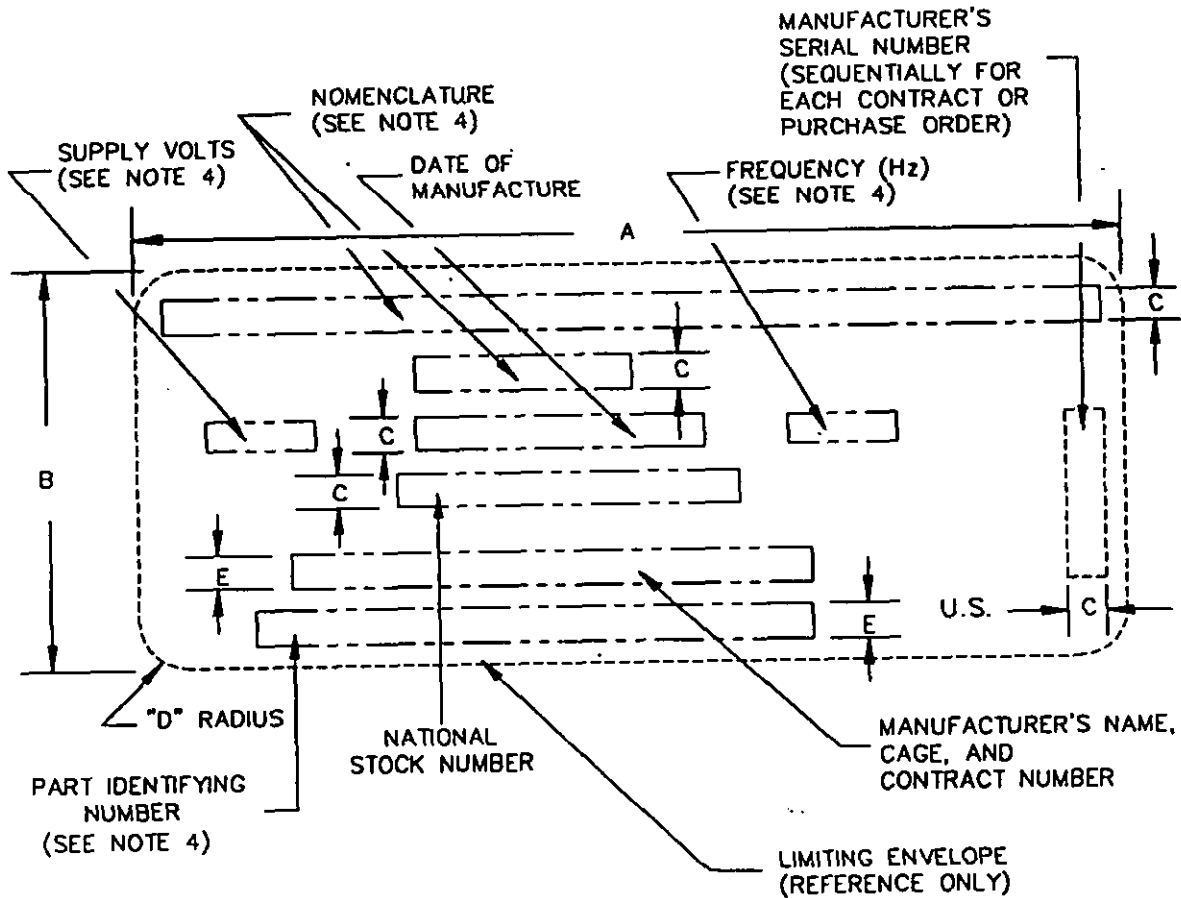

FIGURE 1B. Standard disc for loading size 05 and 08 servocomponent shaft.

NOTES:

1. MATERIAL: ALUMINUM ALLOY, QQ-A-250/4
2. UNLESS OTHERWISE SPECIFIED, DIMENSIONS ARE IN INCHES.
3. TOLERANCES ON DIMENSIONS ARE ± 0.005 .

MIL-S-81963B



SERVOCOMPONENT SIZE	A	B	C	D	E
	INCH	INCH	INCH	INCH	INCH
05	1.50	0.625	0.0625	0.125	0.0625
08	2.25	0.625	0.0625	0.125	0.0625
11, 15	3.00	0.75	0.094	0.125	0.094
18, 23, 31, 37	3.625	1.00	0.094	0.25	0.094

NOTES:

1. DIMENSIONS - MINIMUM SIZE IS SHOWN.
2. LETTERING - GOTHIC OR FUTURA TYPE CAPITALS WITHOUT SERIFS.
3. LEGEND SHALL BE CENTRALLY LOCATED, BOTH HORIZONTALLY AND VERTICALLY.
4. NOMENCLATURE, PART IDENTIFYING NUMBER, VOLTAGE AND FREQUENCY SHALL BE AS SPECIFIED IN THE APPLICABLE GENERAL SPECIFICATION.

FIGURE 2. Standard marking.

MIL-S-81963B

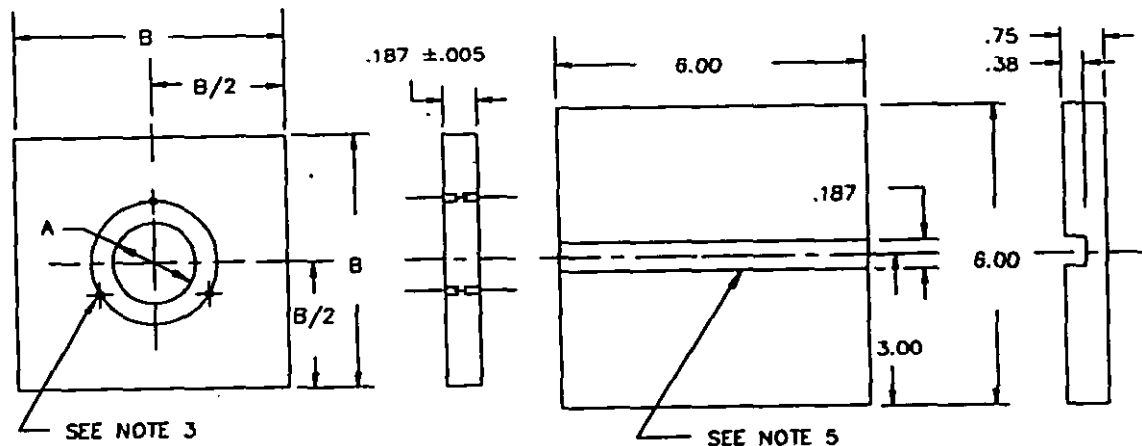

PLATE

MATERIAL: ALUMINUM ALLOY,
QQ-A-250/4

FINISH: ANODIZE PER MIL-A-8625,
TYPE II, CLASS 2 BLACK

BASE

MATERIAL: LAMINATED PHENOLIC

TABLE OF LETTERED DIMENSIONS		
SIZE	A	B ±.010
05	0.376	2.214
08	0.501	2.439
11	1.001	3.200
15	1.313	4.300
18	1.563	5.250

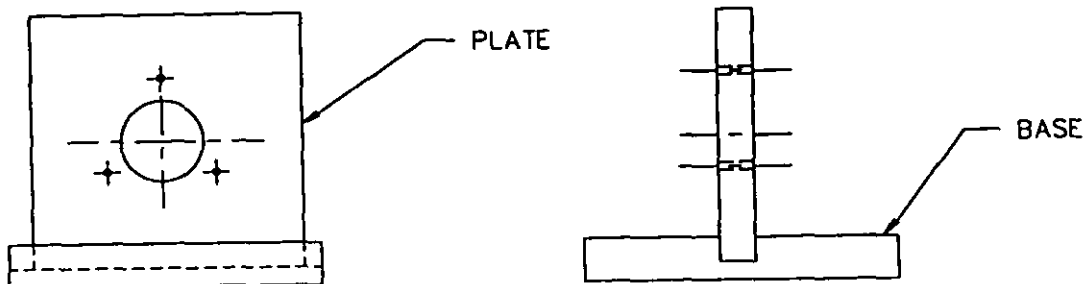

NOTES:

- ALL DIMENSIONS ARE IN INCHES.
- UNLESS OTHERWISE SPECIFIED, TOLERANCES SHALL BE:

2 PLACE DECIMALS	±.02
3 PLACE DECIMALS	+ .010 - .000
- THREE THREADED HOLES EQUALLY SPACED ON A DIAMETER APPROPRIATE FOR THE MOUNTING HARDWARE USED.
- MOUNTING HARDWARE CLAMP ASSEMBLY PER MS17183 OR EQUIVALENT, DIMENSIONED FOR THE PARTICULAR SERVOCOMPONENT.
- SLOT IN BASE SHALL BE LIGHT PRESS FIT WITH PLATE.

FIGURE 3. Standard test fixture for servocomponents up to size 18.

MIL-S-81963B

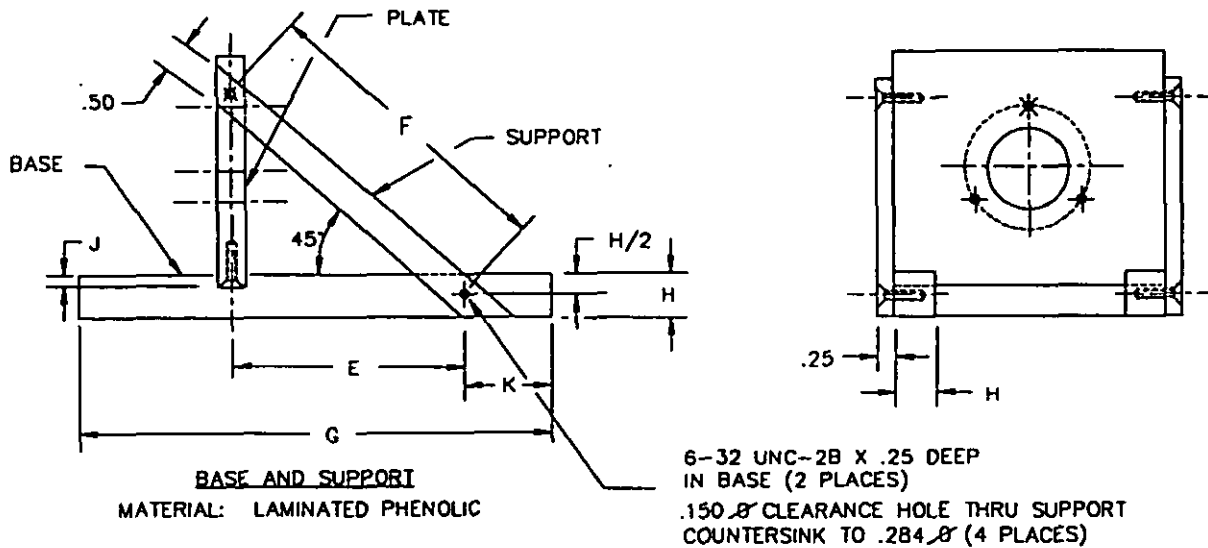
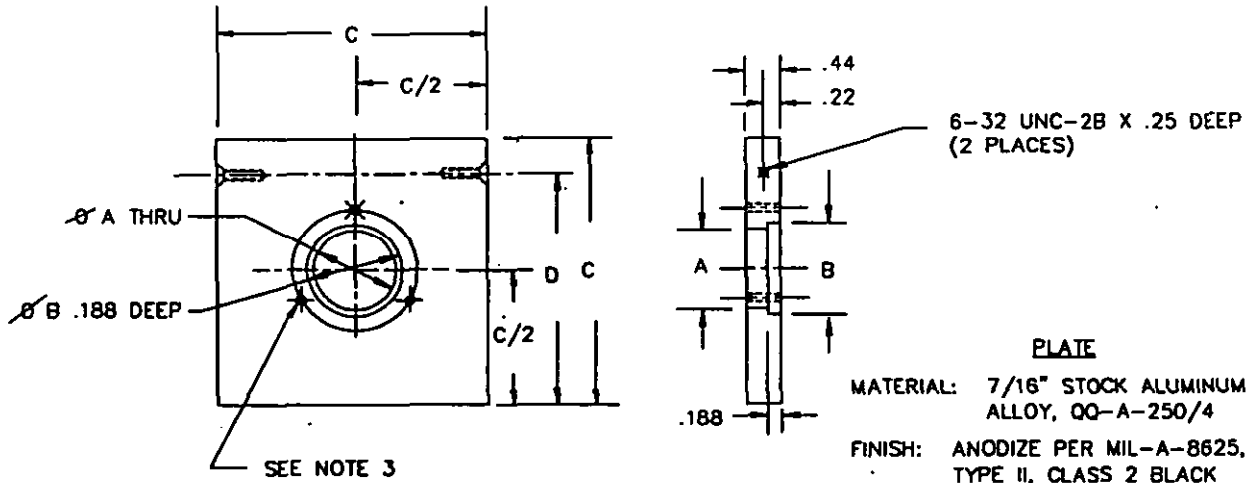

TABLE OF LETTERED DIMENSIONS

SIZE	A	B	C	D	E	F	G	H	J	K
23	2.001	2.260	6.00	4.75	4.875	6.892	9.00	0.75	0.25	1.00
31	2.751	3.110	8.25	4.75	4.875	6.892	9.00	0.75	0.25	1.00
37	3.376	3.635	10.12	9.75	10.250	14.495	20.00	2.00	0.50	2.00

NOTES:

- ALL DIMENSIONS ARE IN INCHES.
- UNLESS OTHERWISE SPECIFIED, TOLERANCES SHALL BE:
 - 2 PLACE DECIMALS $\pm .02$
 - 3 PLACE DECIMALS $+ .010$
 - $- .000$
- THREE THREADED HOLES EQUALLY SPACED ON A DIAMETER APPROPRIATE FOR THE MOUNTING HARDWARE USED.
- MOUNTING HARDWARE CLAMP ASSEMBLY PER MS17183 OR EQUIVALENT, DIMENSIONED FOR THE PARTICULAR SERVOCOMPONENT.

FIGURE 4. Standard test fixture for servocomponents size 23 and larger.

MIL-S-81963B

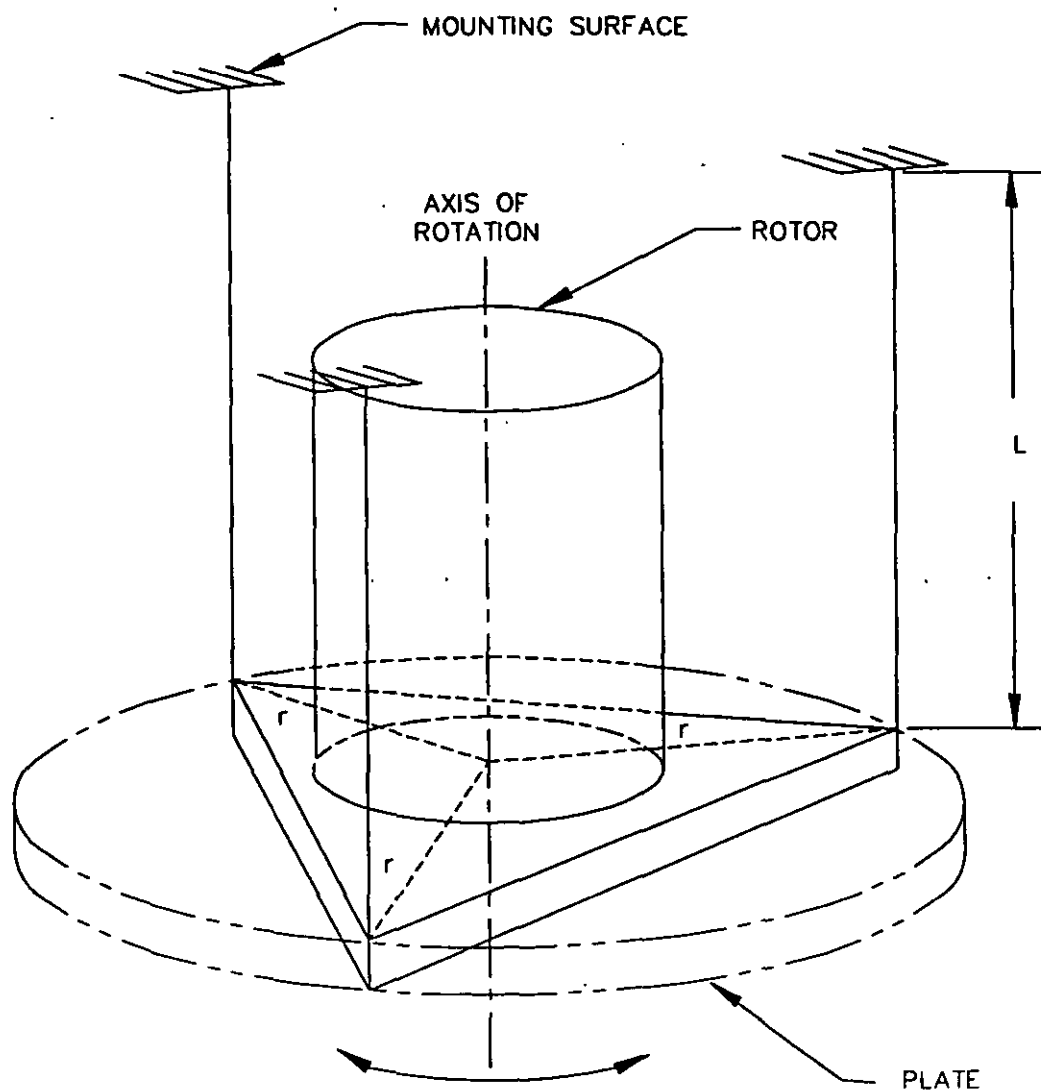
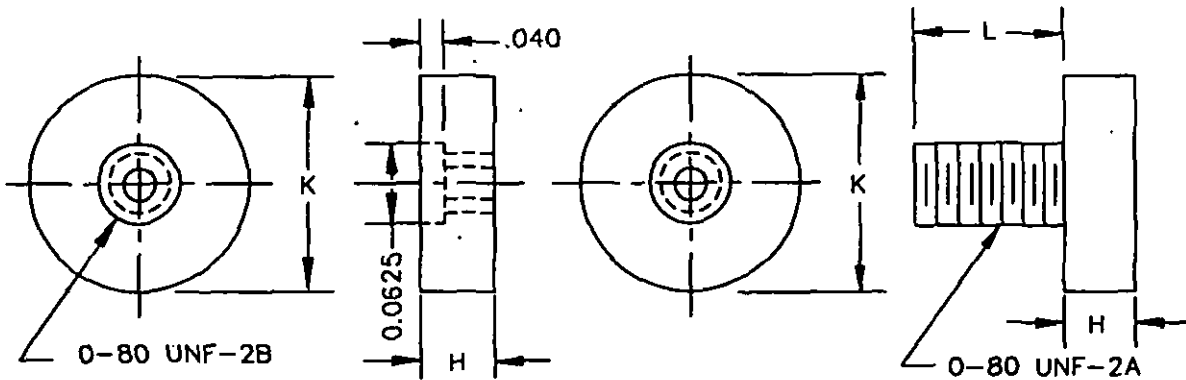

FIGURE 5. Moment of inertia by trifilar suspension with rotor in place.

MIL-S-81963B



DEVELOPED TORQUE	DIMENSIONS OF MOUNTED DIAL WEIGHTS			WEIGHT ± 3 PERCENT	MOUNTING RADIUS
	H	K	L		
oz-in	inch	inch	inch	ounces	inch
.02	.062	.262	.078	.033	.600
.03	.062	.325	.078	.050	.600
.04	.157	.242	.171	.067	.600
.05	.150	.267	.171	.083	.600
.06	.125	.324	.141	.100	.600
.07	.125	.346	.141	.117	.600
.08	.125	.373	.141	.133	.600
.09	.236	.288	.250	.150	.600
.10	.236	.300	.250	.166	.600
.20	.351	.350	.250	.333	.600
.50	.180	.597	.203	.500	1.000

NOTES:

- UNLESS OTHERWISE SPECIFIED, DIMENSIONS ARE IN INCHES. TOLERANCES SHALL BE: ±.005 ON DECIMALS
±1° ON ANGLES
- MATERIAL: BRASS, QQ-B-637, ALLOY NO. 462
- THIS TABLE CONTAINS EXAMPLES OF TORQUE DEVELOPED; OTHER VALUES MAY BE OBTAINED AS REQUIRED.

FIGURE 6. Weights for mechanical breakaway torque tests.

MIL-S-81963B

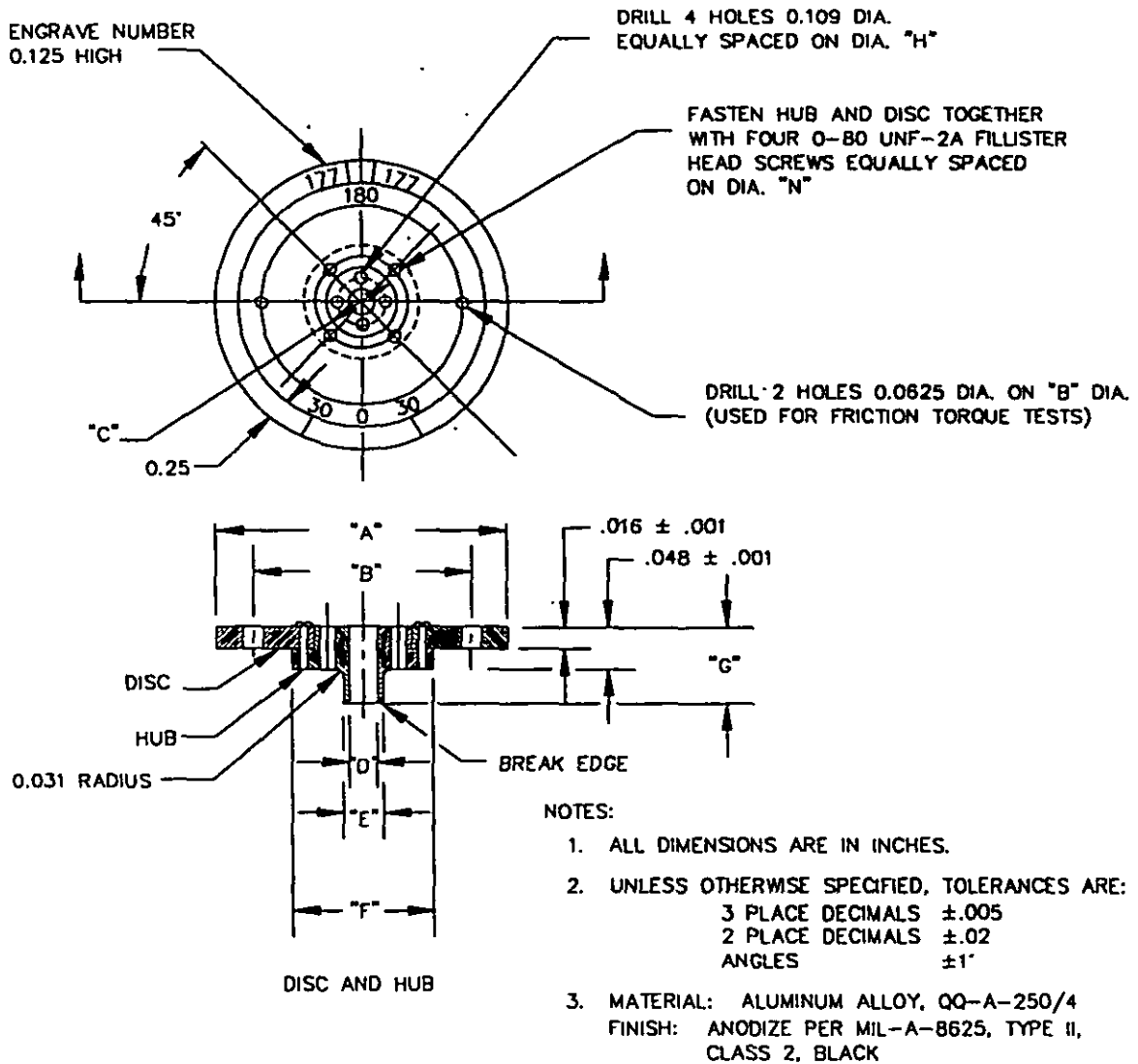

	A	B	C	D	E	F	G	H	N
	-	+ .002 - .002	+ .0004 - .0000	+ .005 - .000	+ .001 - .000	-	+ .005 - .000	-	-
SIZE	inch	inch	inch	inch	inch	inch	inch	inch	inch
05, 08	1.50	1.20	.5625	.1250	.250	.8125	.300	.375	.687
11, 15	1.50	1.20	.5625	.1875	.250	.8125	.300	.375	.687
18	2.00	1.20	.5625	.1875	.250	.8125	.300	.375	.687
23	2.67	2.00	.625	.2410	.3125	.875	.350	.437	.750
31, 37	3.50	2.00	.625	.2410	.3125	.875	.350	.437	.750

FIGURE 7. Dials for mechanical breakaway torque, synchronizing time, and spinning tests.

MIL-S-81963B

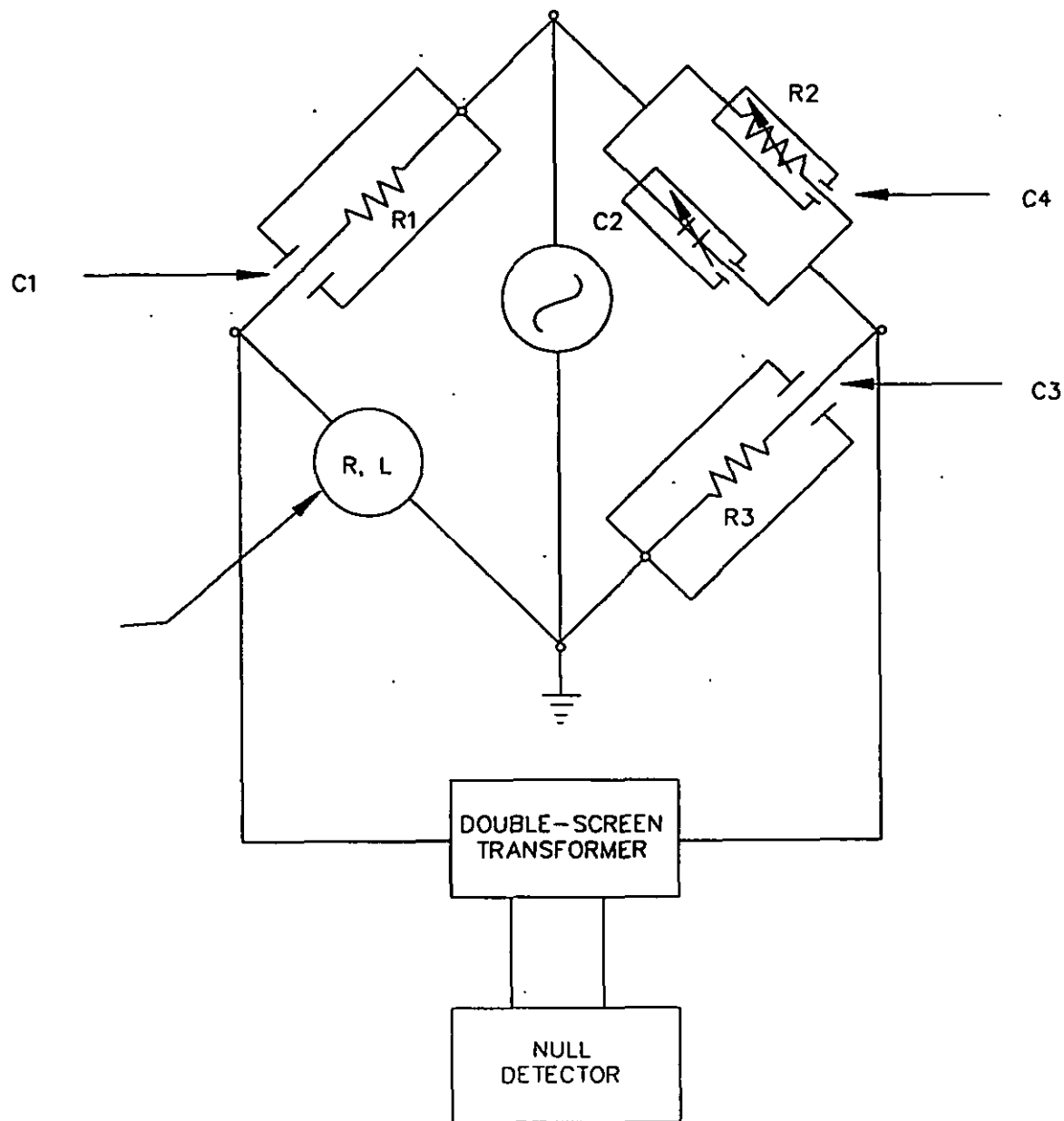

$$R = \frac{R_1 R_3}{R_2} (1 + \omega^2 C_2 C_3 R_2 R_3 - 2\omega^2 R_1 R_3 C_2 C_4)$$

$$\omega = 2\pi f$$

$$L = R_1 R_3 C_2 (1 - \omega^2 R_1 R_3 C_2 C_4)$$

FIGURE 8. Wein-modified Maxwell bridge.

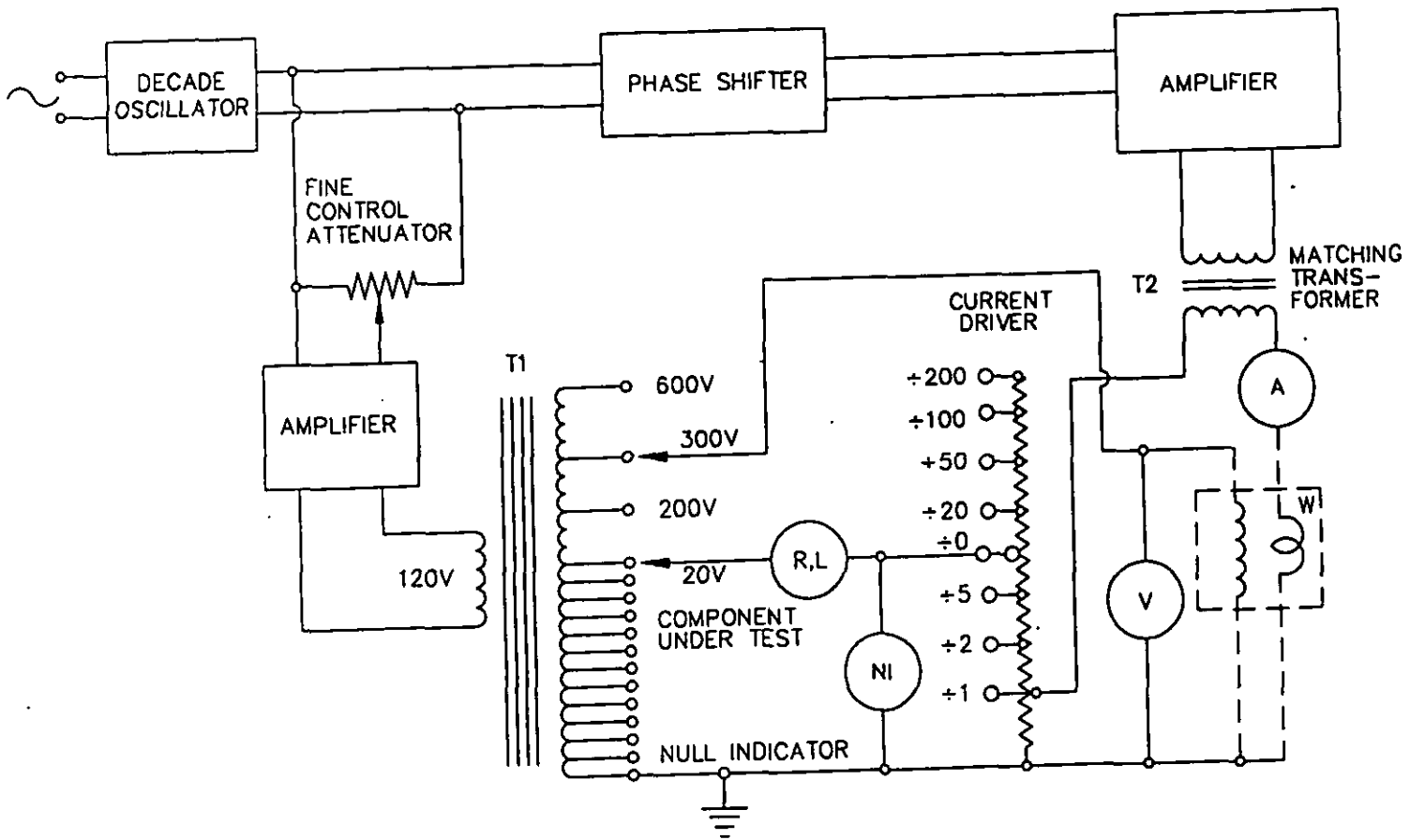
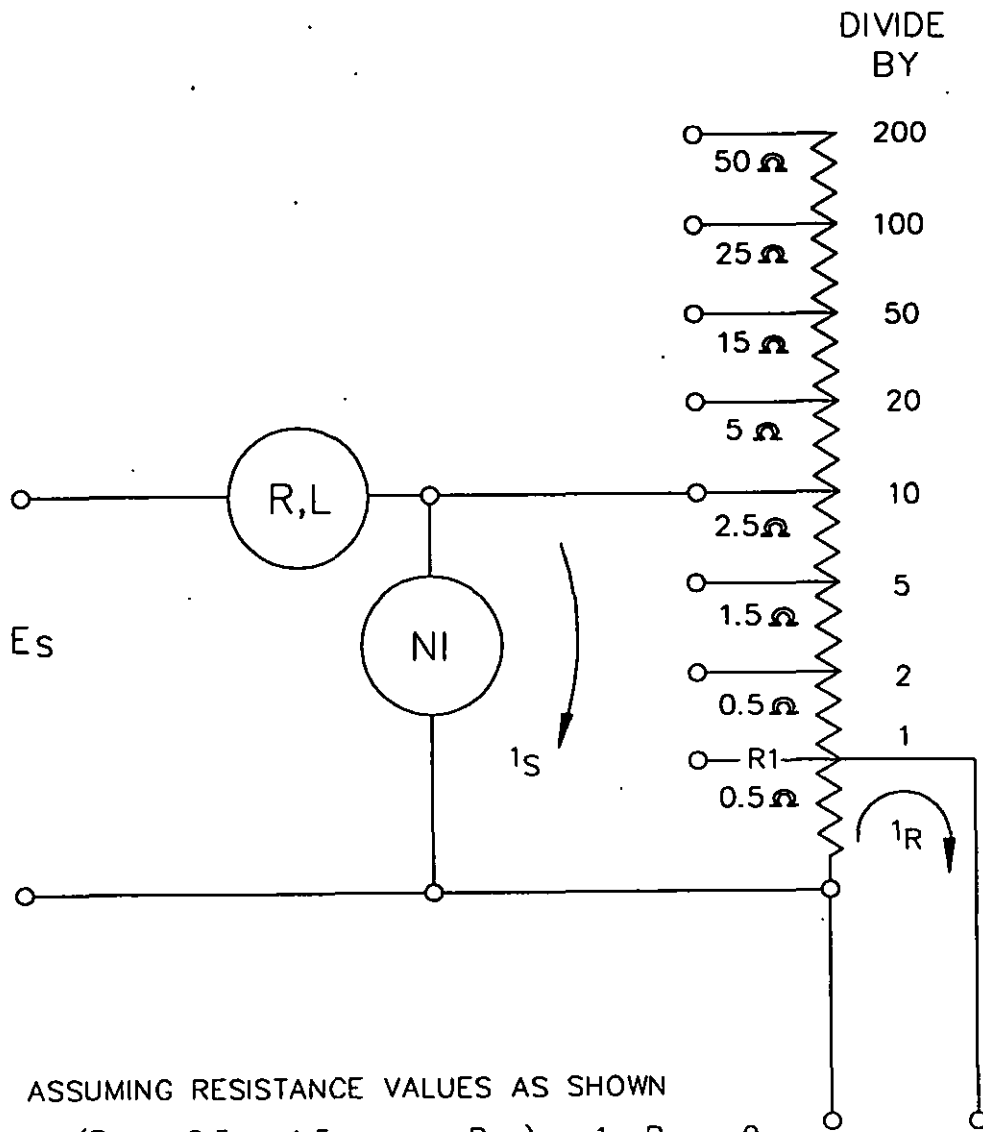

FIGURE 9. Marshall potentiometer.

MIL-S-81963B



ASSUMING RESISTANCE VALUES AS SHOWN

$$I_S (R_1 = 0.5 + 1.5 + \dots + R_n) - I_R R_1 = 0$$

THEREFORE

$$\frac{I_R}{I_S} = \frac{(R_1 + 0.5 + 1.5 + \dots + R_n)}{R_1}$$

FIGURE 10. Current division circuit of Marshall potentiometer.

MIL-S-81963B

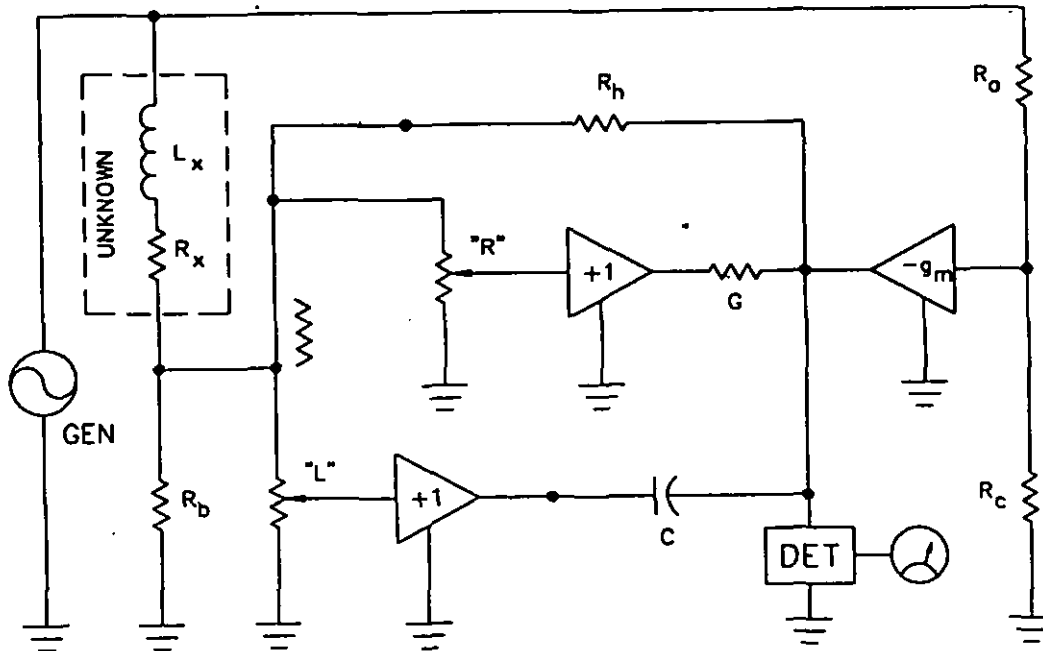

C = Standard Capacitor

G = Standard Resistor

(Values of C and G will be determined by the frequency of the generator (GEN) voltage.

Rectangular Impedance is $R + jX_L$ with R read directly from Dial "R" and the X_L calculated from $X_L = 2\pi FL$ with the L read directly from Dial "L".

Polar Impedance is Z at an angle of θ . The angle derived from $\tan \theta = \frac{R}{X_L}$

Z derived from $Z = \sqrt{R^2 + X_L^2}$

FIGURE 11. Elementary schematic diagram for an incremental induction bridge.

MIL-S-81963B

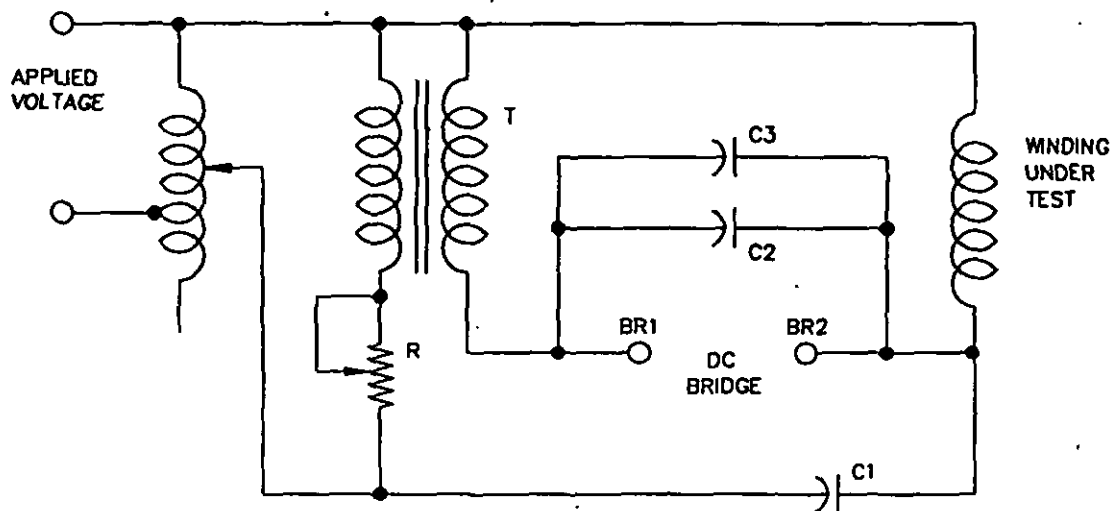

T 1:1 TRANSFORMER RATED AT 250 VA.
 R 250 OHMS, 100 WATTS VARIABLE RESISTOR
 C1, C2, C3, 400 uf, 115 V.A.C. CAPACITORS

NOTE:

1. THE APPLIED AC TO THE CIRCUIT SHOULD BE ADJUSTED SO THAT THE FULL ENERGIZING VOLTAGE IS APPLIED TO THE WINDING. THE TRANSFORMER T HAS ITS SECONDARY AND PRIMARY WINDINGS CONNECTED SO THAT THE AC VOLTAGE ACROSS THE BRIDGE IS LOW, (LESS THAN 1.5 VOLTS). SUITABLE ADJUSTMENTS CAN BE MADE WITH THE VARIABLE RESISTOR "R". THE BRIDGE IS THEN USED TO MEASURE THE KNOWN RESISTANCE OF THE TRANSFORMER T SECONDARY PLUS THAT OF THE WINDING UNDER TEST.

FIGURE 12. Circuit diagram for temperature rise test.

MIL-S-81963B

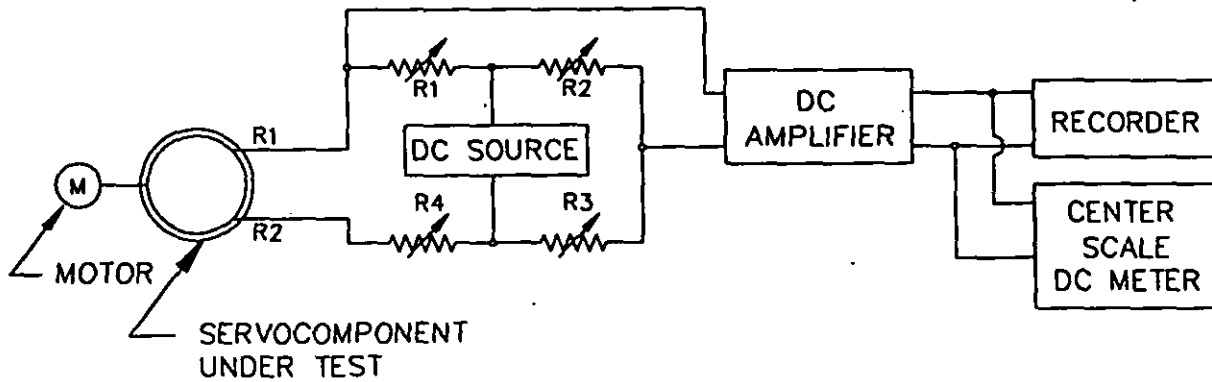

- M - MOTOR, 1 REV/MIN.
 R1 - RESISTOR, DECADE, 1K
 R2, R3 - RESISTOR, DECADE, 10K
 R4 - RESISTOR, DECADE, 10 OHM

NOTE:

1. A CURRENT-LIMITING RESISTOR (1K), IF REQUIRED, WOULD BE CONNECTED IN SERIES WITH THE DC SOURCE.

FIGURE 13. Brush contact resistance variation test circuit.

MIL-S-81963B

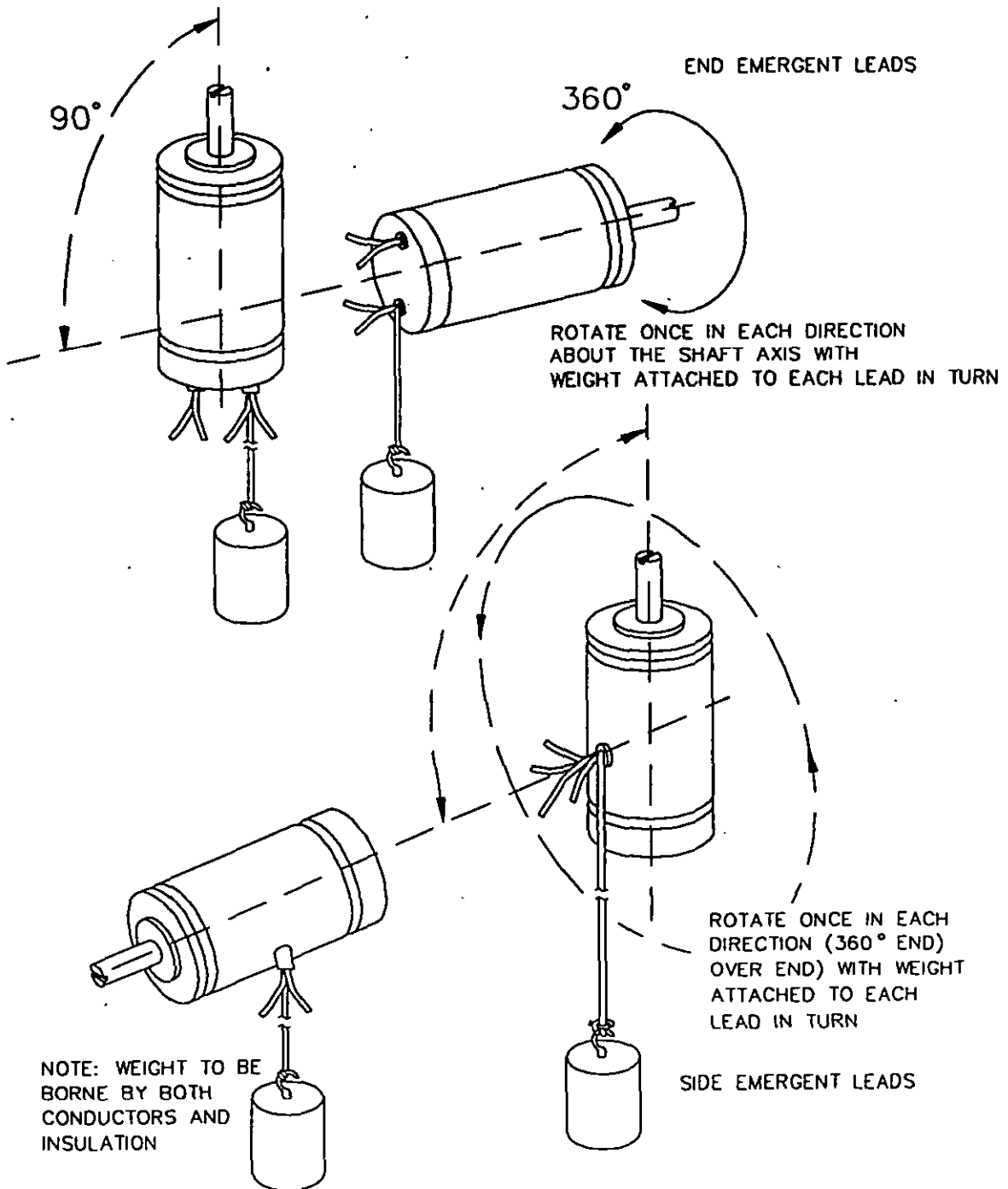
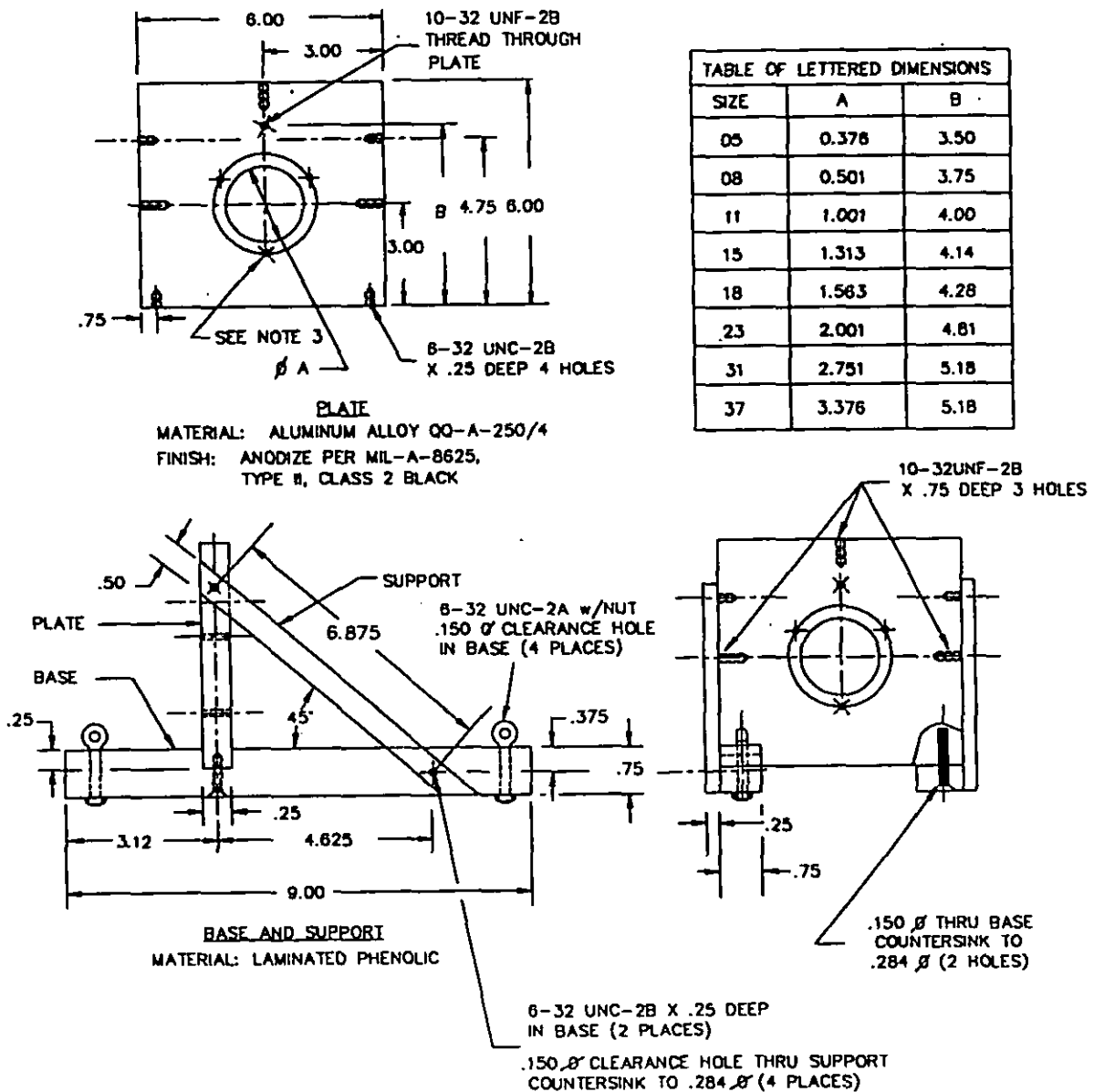

FIGURE 14. Lead wire stress test.

MIL-S-81963B



NOTES:

1. ALL DIMENSIONS ARE IN INCHES.
2. UNLESS OTHERWISE SPECIFIED, TOLERANCES SHALL BE:

2 PLACE DECIMALS	$\pm .02$
3 PLACE DECIMALS	$+ .010$ $- .000$
3. THREE THREADED HOLES EQUALLY SPACED ON A DIAMETER APPROPRIATE FOR THE MOUNTING HARDWARE USED.
4. MOUNTING HARDWARE CLAMP ASSEMBLY PER MS17183, OR EQUIVALENT, DIMENSIONED FOR THE PARTICULAR SERVOCOMPONENT.

FIGURE 15. Structureborne noise test fixture.

MIL-S-81963B

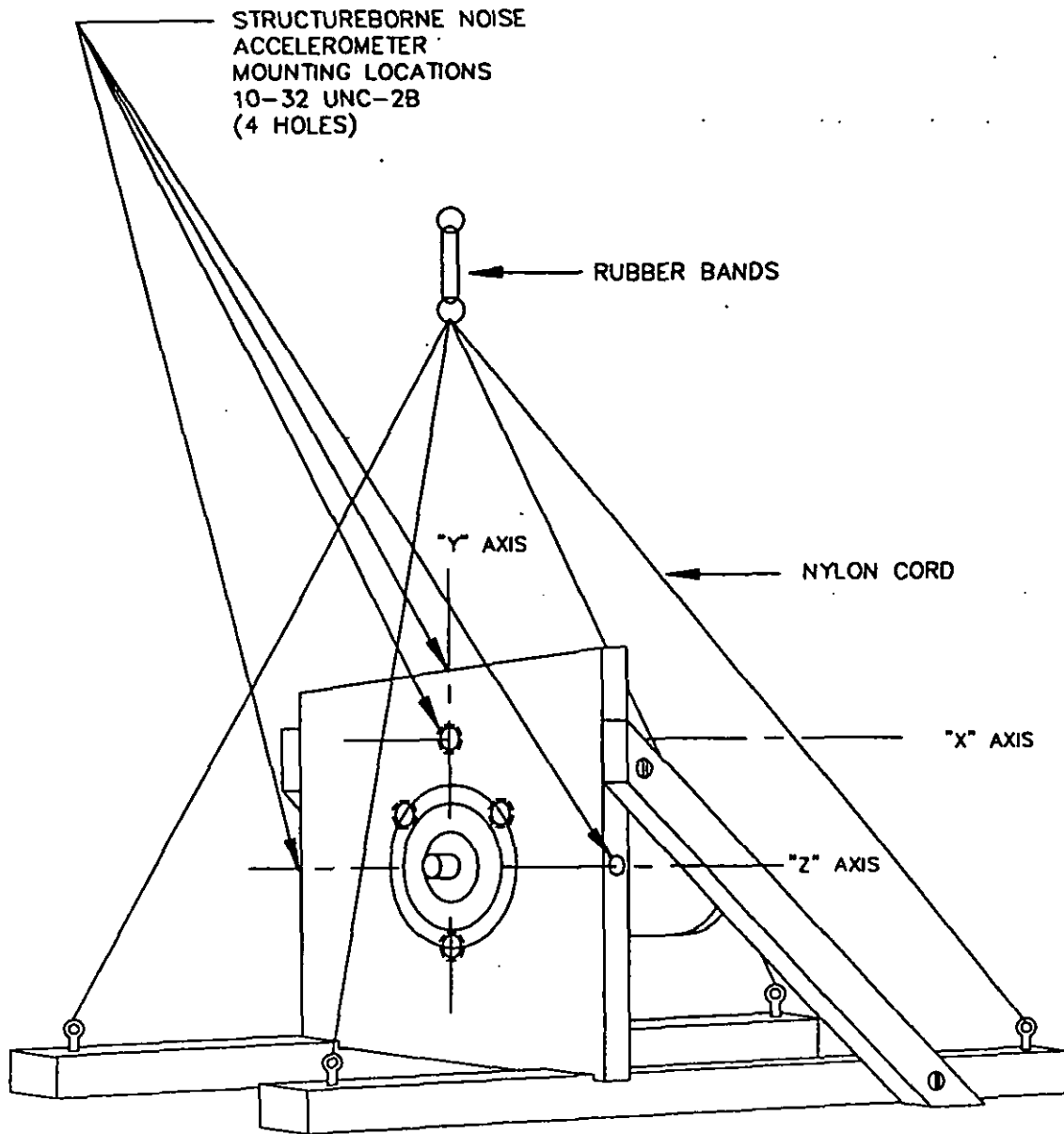

FIGURE 16. Test fixture application for structureborne noise test.

MIL-S-81963B

INDEX

<u>Title</u>	<u>Paragraph</u>	<u>Page</u>
Acquisition requirements	6.2	28
Alternate test methods	4.1.3	13
Altitude, high temperature	3.7.3.2	11
	4.10.3.2	25
Altitude, low temperature	3.7.3.1	11
	4.10.3.1	24
Aluminum	3.4.8	7
Ambient high temperature	3.7.5.2	12
	4.10.5.2	25
Ambient low temperature.	3.7.5.1	12
	4.10.5.1	25
Applicable documents	2.	1
Assessment of qualification approval test results.	4.6.3	15
Audible noise structureborne	3.7.7	12
	4.10.7	26
Ball bearings	3.4.11	7
Breakaway torque	3.6.5	9
	4.9.5	19
Brush contact resistance variation test circuit	Figure 13	46
Changes from previous issue	6.8	30
Circuit diagram for temperature rise test	Figure 12	45
Classification of inspection	4.5	15
Collector rings	3.4.11	7
Consideration of data requirements	6.3	28
Current	3.6.8	9
	4.9.8	20
Current division circuit of Marshall potentiometer	Figure 11	43
Definitions	6.5	29
Degradation of performance	4.6.3.3	16
Detail requirements.	3.1	4
Design and construction	3.5	8
Dials for mechanical breakaway torque, synchronizing time, and spinning tests	Figure 7	40
Dielectric withstanding voltage	3.6.6	9
	4.9.6	20
Dimensions	3.5.3	8
Disposition of qualification sample	4.6.4	16
Dissimilar metals	3.4.6	6
Electrical breakaway torque	3.6.5.2	9
	4.9.5.2	19
Electrical test load condition	4.4	14
Electrolytic corrosion protection	3.4.7	6
Electromagnetic interference	3.6.13	10
	4.9.13	23
Elementary schematic diagram for an incremental induction bridge	Figure 11	44

MIL-S-81963B

INDEX - Continued

<u>Title</u>	<u>Paragraph</u>	<u>Page</u>
Endurance	3.7.4	11
	4.10.4	25
Endurance test time schedule	Table II	33
Environmental	3.7	10
	4.10	24
Explosion resistance	3.7.8	12
First article	3.3	5
	4.5	15
	6.4	29
	4.10.8	27
First article sample failure	4.7.1	16
First article sample inspection	4.7	16
Fungus and moisture resistant materials	3.4.10	7
Government documents	2.1	1
Handbooks.	2.1.1	1
Housing, rotor shaft material.	3.4.2	5
Identification marking	3.7.10	12
Impedance	3.6.10	9
	4.9.10	20
Impregnating and potting compounds	3.4.5	5
Inspection of packaging	4.11	27
Insulating materials	3.4.3	5
Insulation resistance	3.6.7	9
	4.9.7	20
Intended use	6.1	28
International standardization agreement	6.9	30
Lead wire stress test	Figure 14	47
Lubricants	3.4.13	8
Magnet wire	3.4.16	8
Major failures	4.6.3.4	16
Marshall potentiometer	Figure 9	42
Mechanical breakaway torque	3.6.5.1	9
	4.9.5.1	19
Moisture resistance	3.7.6	12
	4.10.6	26
Moment of inertia by torsional oscillations	4.9.4.1	18
Moment of inertia by trifilar suspension	4.9.4.2	18
with rotor in place	Figure 5	38
Mounting fixtures	4.3	14
Non-Government publications	2.2	3
Notes	6.	28
Order of precedence	2.3	4
Other publications	2.2	3
Packaging	5.	28
Packaging and packing	5.1	28
Parts, materials and processes	3.4.1	5

MIL-S-81963B

INDEX - Continued

<u>Title</u>	<u>Paragraph</u>	<u>Page</u>
Performance	3.6	8
Plastics	3.4.4	5
Power	3.6.9	9
	4.9.9	20
Qualification	3.2	5
	6.10	30
Qualification and quality conformance inspection tests . .	Table I	31-32
Qualification approval by analogy	4.6.3.5	16
Qualification inspection	4.6	15
Qualification inspection routine	4.6.2	15
Qualification sample	4.6.1	15
Qualification sample failure	4.6.3.1	15
Qualification sample isolated failure	4.6.3.2	15
Quality assurance provisions	4.	13
Quality conformance inspection	4.8	16
Quality conformance inspection routine	4.8.2	17
Quality conformance inspection sampling.	4.8.1	17
Quality conformance sample failure	4.8.3	17
Relationship with servocomponent class specifications . .	6.6	29
Requalification	4.6.5	16
Requirements	3.	4
Responsibility for compliance	4.1.1	13
Responsibility for inspection	4.1	13
Restricted materials	3.4.9	7
Rotor moment of inertia	3.6.4	9
	4.9.4	18
Salt atmosphere	3.7.9	12
	4.10.9	28
Scope	1.1	1
Screw-thread terminals	3.6.14.2	10
	4.9.14.2	23
Servocomponent zero marking	3.5.2	8
Shaft radial and end play	3.6.3	9
	4.9.2	17
Shaft runout	3.6.3	9
	4.9.3	18
Shock, high impact	3.7.2.2	11
	4.10.2.2	24
Shock, specified pulse	3.7.2.1	11
	4.10.2.1	24
Solder-pin terminals	3.6.14.3	10
	4.9.14.3	24
Soldering	3.4.15	8
Specifications	2.1.1	1
Standard disc for loading size 11, 15, 18, 23, 31, and 37 servocomponent shaftsFigure 1A	34

MIL-S-81963B

INDEX - Continued

<u>Title</u>	<u>Paragraph</u>	<u>Page</u>
Standard disc for loading size 05 and 08 servocomponent shaftsFigure 1B	34
Standard marking Figure 2	35
Standard test conditions	4.2.1	13
Standard test fixture for servocomponents up to size 18 Figure 3	36
Standard test fixture for servocomponents size 23 and larger Figure 4	37
Standards	2.1.1	1
Structureborne noise test fixtureFigure 15	48
Subject term (key word) listing	6.7	30
Temperature conditions of servocomponents under test	4.2.2	14
Temperature rise	3.6.11	9
	4.9.11	22
Temperature, stabilized non-operating	4.2.2.1	14
Temperature, stabilized operating	4.2.2.2	14
Terminal or wire lead strength	3.6.14	10
	4.9.14	23
Termination identification	3.5.1	8
Test fixture application for structureborne noise testFigure 16	49
Test conditions	4.2	13
Test equipment and inspection facilities	4.1.2	13
Test methods and examinations	4.9	17
Test power supplies, etc.	4.2.3	14
Threaded parts	3.4.14	8
Variation of brush contact resistance	3.6.12	10
	4.9.12	22
Vibration	3.7.1	10
	4.10.1	24
Visual and mechanical inspection	4.9.1	17
Weights for mechanical breakaway torque tests	Figure 6	39
Wein-modified Maxwell bridge	Figure 8	41
Wire leads	3.6.14.1	10
	4.9.14.1	23
Workmanship.	3.8	12

MIL-S-81963B

Custodians:

Army - AR
Navy - AS
Air Force - 85

Preparing Activity:

Navy - AS

* Review activities:

Army - MI, AV
Navy - CS, SH
Air Force - 11, 17, 79
DLA - ES

(Project 5990-0360)

* User activities:

Army - AT
Navy - MC, CG
Air Force - 19

STANDARDIZATION DOCUMENT IMPROVEMENT PROPOSAL

INSTRUCTIONS

1. The preparing activity must complete blocks 1, 2, 3, and 8. In block 1, both the document number and revision letter should be given.
2. The submitter of this form must complete blocks 4, 5, 6, and 7.
3. The preparing activity must provide a reply within 30 days from receipt of the form.

NOTE: This form may not be used to request copies of documents, nor to request waivers, or clarification of requirements on current contracts. Comments submitted on this form do not constitute or imply authorization to waive any portion of the referenced document(s) or to amend contractual requirements.

I RECOMMEND A CHANGE: 1. DOCUMENT NUMBER **MIL-S-81963 B** 2. DOCUMENT DATE (YYMMDD) **28 NOV 1990**

3. DOCUMENT TITLE

SERVOCOMPONENTS, PRECISION INSTRUMENT

4. NATURE OF CHANGE (Identify paragraph number and include proposed rewrite, if possible. Attach extra sheets as needed.)

5. REASON FOR RECOMMENDATION

6. SUBMITTER

a. NAME (Last, First, Middle Initial)	b. ORGANIZATION
c. ADDRESS (Include Zip Code)	d. TELEPHONE (Include Area Code) (1) Commercial (2) AUTOVON (If applicable)
	e. DATE SUBMITTED (YYMMDD)

8. PREPARING ACTIVITY

a. NAME SYSTEMS ENGINEERING AND STANDARDIZATION DEPT (53)	b. TELEPHONE (Include Area Code) (1) Commercial (2) AUTOVON 908 373-7258 624-2258
c. ADDRESS (Include Zip Code) NAVAL AIR ENGINEERING CENTER LAKEHURST, NJ 08733-5100	IF YOU DO NOT RECEIVE A REPLY WITHIN 45 DAYS, CONTACT: Defense Quality and Standardization Office 5203 Leesburg Pike, Suite 1403, Falls Church, VA 22041-3466 Telephone (703) 756-2340 AUTOVON 289-2340