

INCH-POUND

MIL-S-24235/2C(SH)

28 December 1992

SUPERSEDING

MIL-S-24235/2B(SH)

21 August 1989

## MILITARY SPECIFICATION SHEET

STUFFING TUBE, PACKING ASSEMBLIES  
FOR PRESSUREPROOF BULKHEAD

This specification is approved for use by the Naval Sea Systems Command, Department of the Navy, and is available for use by all Departments and Agencies of the Department of Defense.

The requirements for acquiring the product described herein shall consist of this specification sheet and the issue of the following specification listed in that issue of the Department of Defense Index of Specifications and Standards (DODISS) specified in the solicitation: MIL-S-24235.

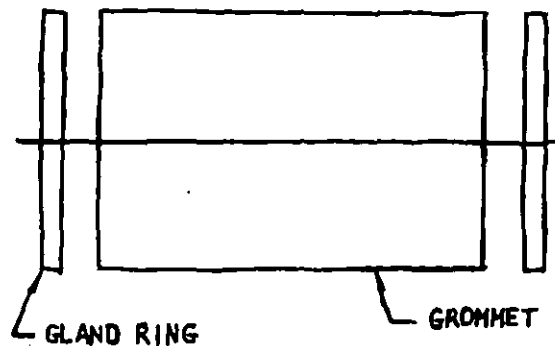

FIGURE 1. Packing assembly for tube sizes 1, 2, and 3.

(01)

## NOTES:

1. Dimensions are in inches.
2. Unless otherwise specified, tolerances shall be as follows:
  - Decimals - plus or minus 0.005 inch.
  - Fractions - plus or minus 1/64 inch.
  - Angular dimensions - plus or minus 30 minutes.
  - Molded parts shall conform to MIL-HDBK-149.

AMSC N/A

1 of 8

FSC 5975

DISTRIBUTION STATEMENT A. Approved for public release; distribution is unlimited.

## MIL-S-24235/2C(SH)

TABLE I. Packing assembly part or identifying numbers for tube sizes 1, 2 and 3.

Tube size <u>1/</u>	Packing assembly part or identifying number	Part or identifying numbers of components		
		Gland ring 4 required	Grommet 2 required	Symbol no.
1	M24235/2-*001	M24235/2-120	M24235/2-*061	2405.1
	M24235/2-*002	M24235/2-121	M24235/2-*062	2405.2
	M24235/2-*003	M24235/2-122	M24235/2-*063	2405.3
	M24235/2-*004	M24235/2-123	M24235/2-*064	2405.4
	M24235/2-*005	M24235/2-124	M24235/2-*065	2405.5
	M24235/2-*006	M24235/2-125	M24235/2-*066	2405.6
	M24235/2-*007	M24235/2-126	M24235/2-*067	2405.7
2	M24235/2-*008	M24235/2-127	M24235/2-*068	2406.1
	M24235/2-*009	M24235/2-128	M24235/2-*069	2406.2
	M24235/2-*010	M24235/2-129	M24235/2-*070	2406.3
	M24235/2-*011	M24235/2-130	M24235/2-*070	2406.5
	M24235/2-*012	M24235/2-131	M24235/2-*071	2406.4
3	M24235/2-*013	M24235/2-132	M24235/2-*072	2407.1
	M24235/2-*014	M24235/2-133	M24235/2-*073	2407.2
	M24235/2-*015	M24235/2-134	M24235/2-*073	2407.5
	M24235/2-*016	M24235/2-135	M24235/2-*074	2407.3
	M24235/2-*017	M24235/2-136	M24235/2-*074	2407.6
	M24235/2-*018	M24235/2-137	M24235/2-*075	2407.7
	M24235/2-*019	M24235/2-138	M24235/2-*076	2407.4

1/ See MIL-S-24235/1.

NOTE: The asterisk "\*" represents item material. The material shall be Neoprene (N) or Silicone (S) in accordance with the part list.

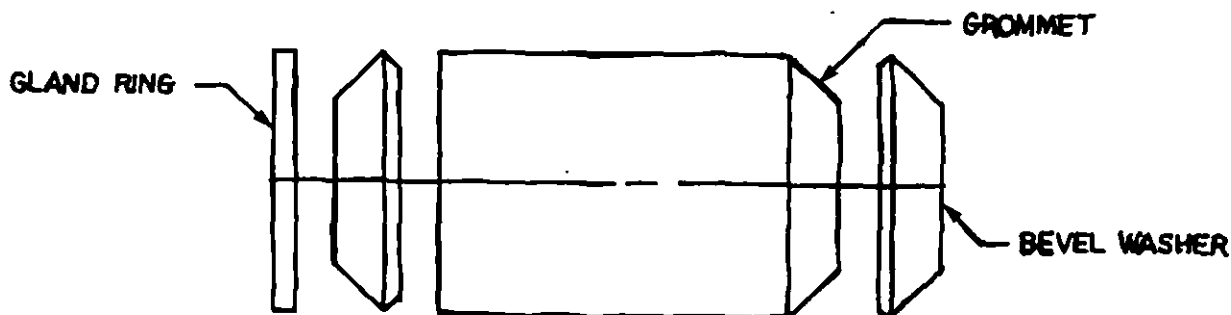

FIGURE 2. Packing assembly for tube sizes 4 through 9.

02

## MIL-S-24235/2C(SH)

TABLE II. Packing assembly part or identifying numbers for tube sizes 4 through 9.

Tube size <u>1/</u>	Packing assembly part or identifying number	Part or identifying numbers of components				Symbol no.
		Gland ring 4 required	Bevel washer 4 required	Grommet 2 required		
4	M24235/2-*030	M24235/2-139	M24235/2-160	M24235/2-*090	2408.5	
	M24235/2-*031	M24235/2-139	M24235/2-161	M24235/2-*091	2408.1	
	M24235/2-*032	M24235/2-139	M24235/2-162	M24235/2-*092	2408.2	
	M24235/2-*033	M24235/2-139	M24235/2-163	M24235/2-*093	2408.3	
	M24235/2-*034	M24235/2-139	M24235/2-164	M24235/2-*094	2408.4	
5	M24235/2-*035	M24235/2-140	M24235/2-165	M24235/2-*095	2409.1	
	M24235/2-*036	M24235/2-140	M24235/2-166	M24235/2-*096	2409.2	
	M24235/2-*037	M24235/2-140	M24235/2-167	M24235/2-*097	2409.3	
6	M24235/2-*038	M24235/2-141	M24235/2-168	M24235/2-*098	2410.1	
	M24235/2-*039	M24235/2-141	M24235/2-169	M24235/2-*099	2410.2	
	M24235/2-*040	M24235/2-141	M24235/2-170	M24235/2-*100	2410.3	
7	M24235/2-*041	M24235/2-142	M24235/2-171	M24235/2-*101	2411.5	
	M24235/2-*042	M24235/2-142	M24235/2-172	M24235/2-*102	2411.1	
	M24235/2-*043	M24235/2-142	M24235/2-173	M24235/2-*103	2411.2	
	M24235/2-*044	M24235/2-142	M24235/2-174	M24235/2-*104	2411.3	
	M24235/2-*045	M24235/2-142	M24235/2-175	M24235/2-*105	2411.4	
8	M24235/2-*046	M24235/2-143	M24235/2-176	M24235/2-*106	2412.1	
	M24235/2-*047	M24235/2-143	M24235/2-177	M24235/2-*107	2412.2	
	M24235/2-*048	M24235/2-143	M24235/2-178	M24235/2-*108	2412.3	
9	M24235/2-*049	M24235/2-144	M24235/2-179	M24235/2-*109	2413.1	
	M24235/2-*050	M24235/2-144	M24235/2-180	M24235/2-*110	2413.2	

1/ See MIL-S-24235/1.

NOTE: The asterisk "\*" represents item material. The material shall be Neoprene (N) or Silicone (S) in accordance with the part list.

## MIL-S-24235/2C(SH)

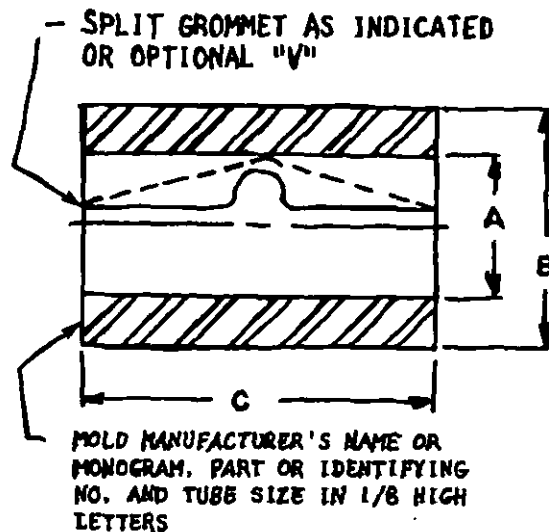

FIGURE 3. Grommet configuration for tube sizes 1, 2 and 3. (03)

TABLE III. Grommet dimensions for tube sizes 1, 2 and 3.

Tube size	Part or identifying number	A DIA	B DIA	C
1	M24235/2-*061	0.312	0.986	1-1/4
	M24235/2-*062	.404	.986	1-1/4
	M24235/2-*063	.455	.986	1-1/4
	M24235/2-*064	.490	.986	1-1/4
	M24235/2-*065	.530	.986	1-1/4
	M24235/2-*066	.558	.986	1-1/4
	M24235/2-*067	.590	.986	1-1/4
2	M24235/2-*068	.636	1.173	1-1/2
	M24235/2-*069	.680	1.173	1-1/2
	M24235/2-*070	.730	1.173	1-1/2
	M24235/2-*071	.800	1.173	1-1/2
3	M24235/2-*072	.836	1.486	1-15/16
	M24235/2-*073	.900	1.486	1-15/16
	M24235/2-*074	.950	1.486	1-15/16
	M24235/2-*075	1.000	1.486	1-15/16
	M24235/2-*076	1.050	1.486	1-15/16

NOTE: The asterisk "\*" represents item material. The material shall be Neoprene (N) or Silicone (S) in accordance with the part list.

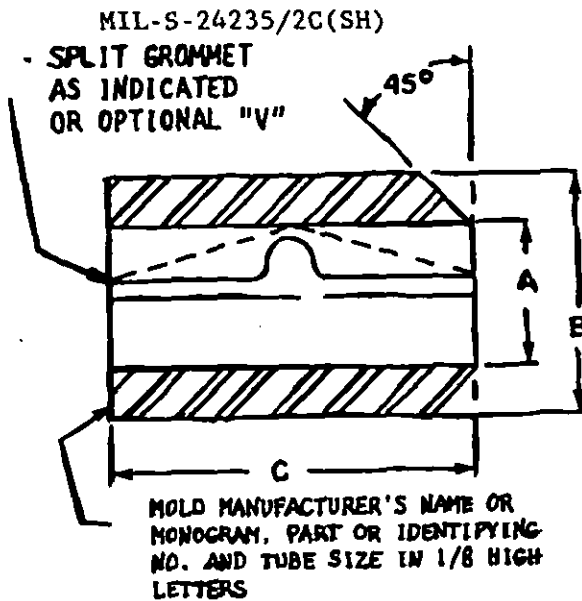

FIGURE 4. Grommet configuration for tube sizes 4 through 9. (04)

TABLE IV. Grommet dimensions for tube sizes 4 through 9.

Tube size	Part or identifying number	A DIA	B DIA	C
4	M24235/2-*090	1.075	1.673	2-1/2
	M24235/2-*091	1.115	1.673	2-1/2
	M24235/2-*092	1.130	1.673	2-1/2
	M24235/2-*093	1.174	1.673	2-1/2
	M24235/2-*094	1.250	1.673	2-1/2
5	M24235/2-*095	1.300	1.923	3
	M24235/2-*096	1.370	1.923	3
	M24235/2-*097	1.415	1.923	3
6	M24235/2-*098	1.470	2.173	3-1/4
	M24235/2-*099	1.525	2.173	3-1/4
	M24235/2-*100	1.570	2.173	3-1/4
7	M24235/2-*101	1.675	2.548	3-1/2
	M24235/2-*102	1.715	2.548	3-1/2
	M24235/2-*103	1.750	2.548	3-1/2
	M24235/2-*104	1.783	2.548	3-1/2
	M24235/2-*105	1.840	2.548	3-1/2
8	M24235/2-*106	1.885	2.861	3-5/8
	M24235/2-*107	2.000	2.861	3-5/8
	M24235/2-*108	2.119	2.861	3-5/8
9	M24235/2-*109	2.200	2.986	3-3/4
	M24235/2-*110	2.250	2.986	3-3/4

NOTE: The asterisk "\*" represents item material. The material shall be Neoprene (N) or Silicone (S) in accordance with the part list.

MIL-S-24235/2C(SH)

STAMP PART OR IDENTIFYING  
NO. AND TUBE SIZE IN 1/8  
HIGH LETTERS

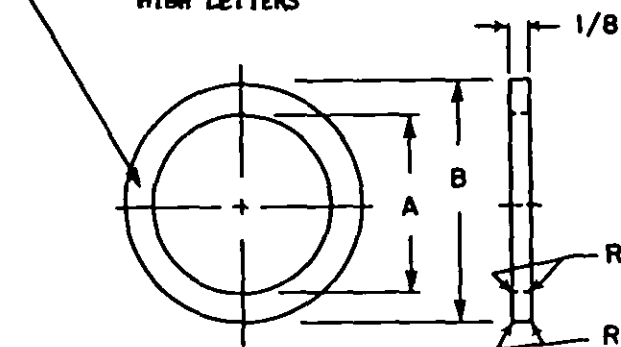
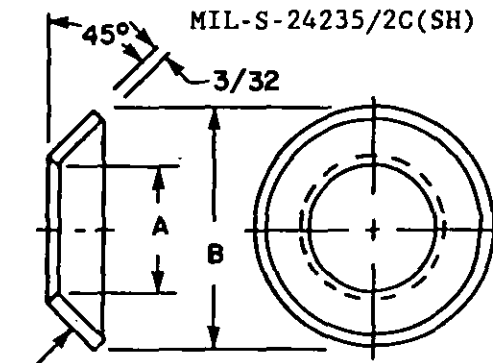

FIGURE 5. Gland configuration. (05)

TABLE V. Gland ring dimensions for tube sizes 1 through 9.

Tube size	Part or identifying number	A DIA	B DIA
1	M24235/2-120	0.323	0.997
	M24235/2-121	.414	.997
	M24235/2-122	.461	.997
	M24235/2-123	.500	.997
	M24235/2-124	.534	.997
	M24235/2-125	.563	.997
	M24235/2-126	.609	.997
2	M24235/2-127	.644	1.184
	M24235/2-128	.695	1.184
	M24235/2-129	.740	1.184
	M24235/2-130	.760	1.184
	M24235/2-131	.812	1.184
3	M24235/2-132	.852	1.497
	M24235/2-133	.905	1.497
	M24235/2-134	.927	1.497
	M24235/2-135	.961	1.497
	M24235/2-136	.992	1.497
	M24235/2-137	1.032	1.497
	M24235/2-138	1.062	1.497
4	M24235/2-139	1.265	1.684
5	M24235/2-140	1.437	1.934
6	M24235/2-141	1.625	2.184
7	M24235/2-142	1.875	2.549
8	M24235/2-143	2.187	2.860
9	M24235/2-144	2.312	2.987



MOLD OR STAMP PART OR IDENTIFYING  
NO. AND TUBE SIZE IN 1/8 HIGH LETTERS

FIGURE 6. Bevel washer configuration. (06)

TABLE VI. Bevel washer dimensions for tube sizes 4 through 9.

Tube size	Part or identifying number	A DIA	B DIA
4	M24235/2-160	1.095	1.704
	M24235/2-161	1.125	1.704
	M24235/2-162	1.140	1.704
	M24235/2-163	1.185	1.704
	M24235/2-164	1.265	1.704
5	M24235/2-165	1.330	1.954
	M24235/2-166	1.375	1.954
	M24235/2-167	1.421	1.954
6	M24235/2-168	1.479	2.184
	M24235/2-169	1.535	2.184
	M24235/2-170	1.625	2.184
7	M24235/2-171	1.690	2.549
	M24235/2-172	1.719	2.549
	M24235/2-173	1.759	2.549
	M24235/2-174	1.793	2.549
	M24235/2-175	1.844	2.549
8	M24235/2-176	1.891	2.860
	M24235/2-177	2.007	2.860
	M24235/2-178	2.123	2.860
9	M24235/2-179	2.209	2.987
	M24235/2-180	2.253	2.987

**REQUIREMENTS:**

- Intended use: The packing assemblies are for MIL-S-24235/1 stuffing tubes. Nuclear bulkhead applications require silicone grommets. Nonnuclear applications permit the use of neoprene for the grommet material.
- Application: See DOD-STD-2003, Section 3.

## MIL-S-24235/2C(SH)

TABLE VII. Parts list.

Item no.	Description <u>1/</u>	Qty <u>2/</u>		Material and specification	Remarks
		1-3	4-9		
01	Packing assemblies (sizes 1 through 3)	-	-	--	See figure 1 and table I
02	Packing assemblies (sizes 4 through 9)	-	-	--	See figure 2 and table II
03	Grommet (50 durometer)	2		Neoprene, class 1, <u>3/</u> MIL-R-15624, color black; or silicone, class 2, ZZ-R-765, colors red or white	See figure 3 and table III
04	Grommet (50 durometer)	2		Neoprene, class 1, <u>3/</u> MIL-R-15624, color black; or silicone, class 2, ZZ-R-765, colors red or white	See figure 4 and table IV
05	Gland ring	4	2	Steel, ASTM A 569, zinc-plated <u>4/</u>	See figure 5 and table V
06	Bevel washer <u>5/</u>	4		Nylon, L-P-410	See figure 6 and table VI

- 1/ See applicable figure and table listed in "Remarks" column for part numbers and dimensions.
- 2/ Quantity is for one complete assembly of each size.
- 3/ See requirements.
- 4/ Zinc plating shall be as specified in ASTM B 633.
- 5/ May be molded.

The previous issue of this specification sheet replaced that part of Drawing NAVSEA No. 815-1197030 covering packing assemblies.

Revision letters are not used to denote changes due to the extensiveness of the changes.

Preparing activity:  
Navy - SH  
(Project 5975-N078-02)