

MIL-R-81729(AS)
8 July 1969

MILITARY SPECIFICATION

RESTRAINT SYSTEMS, AIRCREWMANS

This specification has been approved by the Naval Air Systems Command, Department of the Navy.

1. SCOPE

1.1 Scope - This specification covers the general requirements for lap and shoulder type restraint systems.

1.2 Classification - The restraint system assemblies shall be of the following types and classes:

Type I , Class 1	Belt, Gunners, Safety
Type I , Class 2	Belt, Troop and Turret Gunners
Type I , Class 3	Belt, Passenger
Type I , Class 4	Belt, Aircrewmans
Type II , Class 1	Belt, Pilot's, Lap and Shoulder
Type II , Class 2	Belt, Pilot's Auto Release Cart-Operated
Type III, Class 1	Harness, Pilot's Shoulder, Standard "V" Type
Type III, Class 2	Harness, Pilot's Shoulder, Standard "Y" Type

2. APPLICABLE DOCUMENTS

2.1 The following documents, of the issue in effect on date of invitation for bids or requests for proposal, form a part of this specification to the extent specified herein.

SPECIFICATIONS

Federal

NN-P-530	Plywood, Flat Panel
QQ-C-502	Copper Rods and Shapes, and Flat Products with Finished Edges (Flat Wire, Strips and Bars)

FSC 1680

MIL-R-81729(AS)

SPECIFICATIONS

Federal (Continued)

PPP-B-566	Box, Folding, Paperboard
PPP-B-576	Box, Wood, Cleated, Veneer, (Paper Overlaid)
PPP-B-591	Box, Fiberboard, Wood Cleated
PPP-B-601	Box, Wood, Cleated-Plywood
PPP-B-636	Box, Fiberboard
PPP-B-676	Box, Setup

Military

MIL-P-116	Preservation, Methods of
MIL-T-781	Terminal, Wire Rope, Swaging

STANDARDS

Military

MIL-STD-105	Sampling Procedures and Tables for Inspection by Attributes
MIL-STD-129	Marking for Shipment and Storage
MIL-STD-130	Identification Marking of U.S. Military Property
MS16036	Belt, Aircraft Safety, Pilot's, Automatic Release Cartridge Operated
MS16068	Harness, Aircraft Safety, Pilot's Shoulder V Type
MS16069	Harness, Aircraft Safety, Pilot's Shoulder Y Type
MS90368	Belt, Safety, Passenger

Air Force - Navy Aeronautical Standard

AN6506	Belt Assembly - Troop and Turret Gunner's Safety
--------	--

MIL-R-81729(AS)

DRAWINGS

Bureau of Naval Weapons

60A135E1	Belt, Crewman's, Safety
62A92H1	Belt, Aircraft Safety, Pilot's, Automatic Release, Cartridge Operated
62A125D1	Shoulder Harness Assembly, Pilot's Safety
62A127D1	Shoulder Harness Assembly, Pilot's Standard "Y" Type
62A129E1	Belt, Gunners, Safety

(When requesting any of the applicable documents, refer to both title and number. All requests should be made via the cognizant Government quality assurance representative. Copies of this specification and other unclassified specifications, standards and drawings required by contractors in connection with specific procurement functions should be obtained upon application to the Commanding Officer, Naval Publications and Forms Center, (Code 1051), 5801 Tabor Avenue, Philadelphia, Pennsylvania 19120. All other documents should be obtained from the procuring activity or as directed by the contracting officer.)

3. REQUIREMENTS

3.1 First article - Unless otherwise specified (see 6.2) the restraint system furnished under this specification shall be a product which has been inspected and has passed the first article inspection specified herein.

3.2 Materials and components - Materials and components shall conform to applicable specifications and drawings as listed herein and on applicable drawings.

3.2.1 Protective treatment - When materials are used in the construction of the restraint systems that are subject to deterioration when exposed to environmental conditions likely to occur during service usage, they shall be treated against such deterioration in such a manner that will in no way prevent compliance with the performance requirements of this specification. Protective coatings which might crack, chip, or scale during normal service life or under extremes of environmental conditions shall not be used.

3.3 Design and construction - Each restraint system shall be designed and constructed in accordance with the applicable drawings. The applicable drawing for each system is as follows:

MIL-R-31729(A3)

ASSEMBLY	APPLICABLE DWG.
Type I , Class 1	62A129E1
Type I , Class 2	AN6506
Type I , Class 3	MS90368
Type I , Class 4	60A135E1
Type II , Class 1	62A125D1
Type II , Class 2	62A92H1
Type III, Class 1	MS16068
Type III, Class 2	62A127D1

3.4 Performance -

3.4.1 Working load - Each assembled restraint system shall be capable of withstanding the working loads specified in Table I, applied for a period of 30 seconds, when tested as specified in Section 4. There shall be no evidence of failure, slippage, or damage to the webbing, stitching or metal and the release mechanism of the buckle and latch shall operate without difficulty.

3.4.2 Proof load - Each assembled restraint system shall be capable of withstanding the proof loads specified in Table I, applied for a period of 30 seconds, when tested as specified in Section 4. There shall be no evidence of failure, slippage, or damage to the webbing, stitching or metal parts and the release mechanism of the buckle and latch shall operate without difficulty.

3.4.3 Quick release - The buckles and latch loops shall be an automatic locking type with one hand disconnect. The force required, when tested as specified in Section 4, shall be as indicated in Table I.

3.4.4 Gun barrel hydrostatic pressure (Type II, Class 2) - When tested as specified in Section 4 the barrel shall show no evidence of deformation.

3.5 Workmanship - The restraint systems shall be constructed and assembled to produce an item free from all defects which would affect proper functioning in service. Particular attention shall be given to neatness, finish, and freedom of parts from all burrs and sharp edges. The restraint systems shall conform to the quality and grade of product established by this specification. The occurrence of defects shall not exceed the acceptance criteria established herein.

3.6 Identification - Identification marking shall be in accordance with MIL-STD-130.

4. QUALITY ASSURANCE PROVISIONS

4.1 Responsibility for inspection - Unless otherwise specified in the contract or purchase order, the supplier is responsible for the performance of all

TABLE I
FORCE REQUIREMENTS

	TYPE I Class 1	TYPE I Class 2	TYPE I Class 3	TYPE I Class 4	TYPE II Class 1	TYPE II Class 2	TYPE III Class 1	TYPE III Class 2
	LBS	LBS	LBS	LBS	LBS	LBS	LBS	LBS
Working load (lap)	4000	2500	2500	2000	6000	6000		
Proof load (lap)	9000	4500	5000		9000	9000		
Working load (shoulder)					3000		2775	3000
Proof load (shoulder)					3500		3775	4000
Quick release	45		40	20	20	20		
Working load (cable assembly)						550		
Firing pin sear release force						31 ±3-1/2		
Actuator release force (safety wired)						235		
Actuator release force (without safety wire)						175		
Firing pin energy (penetration)						0.065 <u>1/</u> to 0.073 in.		

1/ The values given represent depth, in inches, of penetration into a soft copper pellet.

MIL-R-81729(AS)

inspection requirements as specified herein. Except as otherwise specified in the contract or order, the supplier may use his own or any other facilities suitable for the performance of the inspection requirements specified herein, unless disapproved by the Government. The Government reserves the right to perform any of the inspections set forth in the specification where such inspections are deemed necessary to assure that supplies and services conform to prescribed requirements.

4.2 Classification of inspection - The examination and testing of the restraint system assemblies shall be classified as follows:

- (a) First article inspection - First article inspection consists of examination and tests performed on restraint system assemblies which are representative of the production item after award of a contract to determine that the production item conforms to the requirements of this specification (see 4.3).
- (b) Quality conformance inspection - Quality conformance inspection consists of examinations and tests performed on individual products or lots to determine conformance of the products or lots with requirements set forth in this specification (see 4.4).

4.3 First article inspection - First article inspection shall consist of all tests and examinations listed in this specification.

4.3.1 First article inspection samples - Unless otherwise specified, as soon as practicable after award of the contract or order, the manufacturer shall submit three first article samples together with 10 yards of webbing, 1/4 pound of thread on spool, and two each of all hardware used in the restraint systems. The samples shall be representative of the construction, workmanship, components and materials to be used during production. When a manufacturer is in continuous production of these assemblies from contract to contract, submission of further first article inspection samples on the new contract may be waived at the discretion of the procuring activity (see 6.2). Approval of the first article inspection sample or the waiving of the first article inspection does not preclude the requirements for performing the quality conformance inspection. The first article inspection samples shall be furnished to the Government as directed by the contracting officer (see 6.2). The samples shall be plainly marked with the following information:

Samples submitted by (name) (date) for first article inspection in accordance with the requirements of MIL-R- (AS) under Contract No.

MIL-R-81729(AS)

4.3.1.1 Upon the completion of the first article inspection, all the applicable inspection reports, and when applicable, recommendations and comments pertinent for use in monitoring production shall be forwarded to the cognizant Government Activity. One assembly shall be returned to the manufacturer for use in monitoring production. The remaining samples shall be consumed or destroyed in the first article inspection and shall not be considered as a part of the quantity to be delivered under contract.

4.4 Quality conformance inspection - The quality conformance inspection shall consist of the following:

- Visual examination
- Dimensional examination
- Working load
- Quick release
- Hydrostatic pressure
- Proof load of Cable Assembly
- Firing pin sear release force
- Firing pin energy
- Actuator release force (safety wired)
- Actuator release force (without safety wire)
- Tests and examinations at a laboratory
- Preparation for delivery

4.4.1 Sampling -

4.4.1.1 Inspection lot -

4.4.1.1.1 Restraint system - An inspection lot size shall be expressed of one Type and Class of restraint system complete with all components. An inspection lot shall consist of an assembly of one Type and Class, complete with all components made under essentially the same conditions and from the same materials and components. The sample unit shall be one assembly.

4.4.1.1.2 Preparation for delivery - An inspection lot shall be expressed in units of one fully prepared shipping container, containing restraint system assemblies fully prepared for delivery, made from essentially the same materials and components. The sample unit shall be one shipping container, containing restraint system assemblies fully prepared for delivery with the exception it need not be sealed.

4.4.1.2 Sampling for tests and examinations of the restraint system assemblies - The sample size, acceptance criteria, tests and examinations required for the restraint system assemblies shall be as specified in Table II and 4.4.1.3.

MIL-R-81729(AS)

4.4.1.3 Sampling for tests and examinations of the restraint system at a laboratory - Upon the completion of the tests and examinations specified in Table II, a random sample shall be selected from each lot in accordance with MIL-STD-105, Inspection Level S-3. The sample size (quantity of restraint system assemblies selected) shall be governed by the acceptable quality level of 1.5 defects per 100 units. Each assembly selected as a sample unit shall be forwarded to the Government laboratory selected by the cognizant Government Activity (see 6.3) for the following tests and examinations:

TABLE II
SAMPLE SIZE, ACCEPTANCE CRITERIA, EXAMINATIONS
AND TESTS OF THE RESTRAINT SYSTEM ASSEMBLY

INSPECTION	METHOD	SAMPLING	ACCEPTABLE QUALITY LEVEL ^{1/}
Visual examination	4.5.1	Every unit for critical defects. Inspection Level II for minor defects	Reject all units with any critical defect. An acceptable quality level of 1.5 defects per 100 units for minor defect
Dimensional exam.	4.5.1	Inspection Level S-2	
Preparation for Delivery	4.5.2	Inspection Level S-2	An acceptable quality level of 4.0 defects per 100 units
Working load	4.5.3	Inspection Level S-2	An acceptable quality level of 1.5 defects per 100 units
Proof load ^{2/}	4.5.4	Inspection Level S-2	An acceptable quality level of 1.5 defects per 100 units
Quick release	4.5.5	Inspection Level S-2	An acceptable quality level of 1.5 defects per 100 units
Hydrostatic pressure	4.5.6	Inspection Level S-2	An acceptable quality level of 1.5 defects per 100 units
Working load of Cable Assembly	4.5.7	Inspection Level S-2	An acceptable quality level of 1.5 defects per 100 units
Firing pin sear release force	4.5.8	Inspection Level S-2	An acceptable quality level of 1.5 defects per 100 units.
Firing pin energy	4.5.9	Inspection Level S-2	An acceptable quality level of 1.5 defects per 100 units

MIL-R-81779(AS)

TABLE II (Continued)

SAMPLE SIZE, ACCEPTANCE CRITERIA, EXAMINATIONS
AND TESTS OF THE RESTRAINT SYSTEM ASSEMBLY

INSPECTION	METHOD	SAMPLING	ACCEPTABLE QUALITY LEVEL 1/
Actuator release (wired)	4.5.10	Inspection Level S-2	An acceptable quality level of 1.5 defects per 100 units
Actuator release (unwired)	4.5.11	Inspection Level S-2	An acceptable quality level of 1.5 defects per 100 units

1/ The sampling plan acceptance number shall apply collectively to all the characteristics within a stated acceptable quality level.

2/ Units submitted to this test shall not be shipped as part of the contract or order.

4.5 Inspection methods -

4.5.1 Visual examination - Each of the assemblies selected in accordance with Table II and 4.4.1.3 shall be examined visually to determine conformance to this specification. The classification of defects, Table III, shall be used to classify the defects found. For dimensional defects, each assembly selected as a sample unit from the lot shall be thoroughly checked dimensionally to determine conformance to this specification. The classification of defects for finished dimensions, Table IV, shall be used to classify the defects found.

TABLE III

CLASSIFICATION OF DEFECTS FOR VISUAL EXAMINATION

DEFECTS	CRITICAL	MINOR
Any hole, scissor or knife cut, tear, patch or mend	X	
Incorrect assembling or improper positioning of component	X	
Incorrect or incomplete marking		X
Color not as specified		X
Any functioning part that works with difficulty	X	
Any component missing, malformed, fractured or otherwise damaged	X	
Missing stitches, patterns not as specified	X	
Backstitching missing, broken stitches, or runoffs	X	
Not type stitch or thread size specified	X	

MIL-R-81729(AS)

TABLE IV

LIST OF DEFECTS FOR FINISHED DIMENSIONS

EXAMINE	DEFECT
Measure all visible components of the restraint system assembly	Any measurement deviating from the dimensions and tolerances as specified in this specification and applicable drawings shall be classified as a dimensional defect.

4.5.2 Preparation for delivery - Each of the fully prepared shipping containers, containing restraint system assemblies, selected as a sample unit from the lot, shall be visually examined to determine that the packaging, packing and marking conform to this specification. The classification of defects, Table V, shall be used to classify the defects found.

TABLE V

CLASSIFICATION OF DEFECTS FOR PREPARATION FOR DELIVERY

ITEM	DEFECT
Exterior and interior markings	Missing, incorrect, incomplete, illegible, of improper size, location, sequence or method of application; marking not the same on interior and exterior containers.
Packaging and packing materials	Any nonconforming component, any component missing, damaged or otherwise defective.
Workmanship	Inadequate application of components such as incomplete closure of the unit package, intermediate package, container flaps, or loose strappings, etc., bulging or distortion of the container.
Exterior and interior weight or content	Number per container is more or less than required; gross or net weight exceeds the requirement.

4.5.3 Working load -

4.5.3.1 Type I, Class 1 assembly - The assembly, as shown in Figure 1, shall be passed around two pins which are approximately 2 inches in diameter and which shall be attached to the moving and stationary heads of a tensile testing machine. With the belt buckle locked in place, the heads shall be separated at a rate of 1/2 inch per minute (under no load) until a tensile load of 4000 pounds has

MIL-R-81729(AS)

been attained and maintained for a period of 30 seconds. There shall be no failure nor evidence of weakening caused by stretching of the stitching between the 1-3/4 inch webbing and the 3 inch webbing. In addition there shall be no evidence of deformation of the metal parts.

4.5.3.2 Type I, Class 2 assembly - The assembly with the buckle locked shall be passed over a belt support block conforming to Figure 2 and assembled in the testing machine as shown in Figure 3. The unit shall be capable of withstanding the loads specified in Table I for a period of 30 seconds without failure of any portion of the assembly, and after the release of such load, the release buckle shall work freely. The heads of the testing machine shall be separated at a rate of 1/2 inch per minute (under no load).

4.5.3.3 Type I, Class 4 assembly - The assembly shall be assembled in a testing machine in the manner shown in Figure 4a. The quick release buckle shall be closed and the webbing passed over the test block, which shall conform to Figure 2. The anchor snap shall be attached to the lower head of the testing machine. A minimum of 12 inches of the single ply webbing shall be exposed to the working load test as illustrated in Figure 4a. Load shall be applied at a rate of separation of the heads of 1/2 inch per minute (under no load) until the load specified in Table I has been attained and held for a period of 30 seconds. After removal of the load there shall be no evidence of deformation and there shall be no weakening of the assembly nor failure of the stitching or webbing.

4.5.3.4 Type I, Class 3, Type II, Class 2 assemblies - The assemblies, with the buckle and latch locked in place shall be placed over a belt support block conforming to Figure 2 and assembled in a testing machine as shown in Figure 5a. The end fittings, with bushings in place, shall be attached to the lower head of the testing machine in such a manner as to result in the angle shown. Load shall be applied at a rate of separation of heads of 1/2 inch per minute (under no load) until the load indicated in Table I has been attained and held for a minimum of 30 seconds. During the application of the load there shall be no slippage of the webbing through the adjustment loops. After removal of the load the hardware shall show no deformation and there shall be no weakening of the assembly nor failure of the stitching or webbing.

4.5.3.5 Type II, Class 1, lap belt assembly - The assembly, with the buckle and latch locked in place shall be passed over a belt support block conforming to Figure 2 and assembled in a testing machine as shown in Figure 5. The end fittings, with bushings in place, shall be attached to the lower head of the testing machine in such a manner as to result in the angle shown. Load shall be applied at a rate of separation of heads of 1/2 inch per minute (under no load) until the loads specified in Table I have been attained and held for a minimum of 30 seconds. During the application of the load there shall be no slippage of the webbing through the adjustment loops. After removal of the load, the hardware shall show no signs of deformation and there shall be no weakening of the assembly nor failure of the webbing or stitching.

MIL-R-31729(AS)

4.5.3.5.1 Type II, Class 1, shoulder strap assembly - The assembly shall be assembled in a testing machine as shown in Figure 6. The loads specified in Table I shall be applied at a rate of separation of heads of 1/2 inch per minute (under no load) and maintained for a minimum of 30 seconds and the assembly shall not fail nor show signs of weakening in the stitching. In addition, there shall be no slippage of the webbing through the adjustment loops during application of the load.

4.5.3.6 Type III, Class 1 assembly - The assembly shall be placed in a testing machine as shown in Figure 7 with the left and right straps adjusted to equal lengths. A working load, as specified in Table I, shall then be gradually applied to the assembly, at a rate of separation of the heads of 1/2 inch per minute (under no load). After the load has been applied for a period of 30 \pm 3 seconds it shall be removed. There shall be no evidence of failure.

4.5.3.7 Type III, Class 2 assembly - The assembly shall be placed in a testing machine as shown in Figure 8 with the left and right straps adjusted to equal lengths. A working load, as specified in Table I, shall then be gradually applied to the assembly, at a rate of separation of the heads of 1/2 inch per minute (under no load). After the load has been applied for a period of 30 \pm 3 seconds it shall be removed. There shall be no evidence of failure.

4.5.4 Proof load -

4.5.4.1 Type I, Class 1 assembly - The assembly shall be assembled as shown in Figure 1. With the buckle locked in place a proof static load as specified in Table I shall be applied at a rate of separation of heads of 1/2 inch per minute (under no load) and maintained for a minimum of 30 seconds with no weakening of the hardware or webbing at any point. After release of the load the release buckle shall work freely.

4.5.4.2 Type I, Class 2 assembly - The assembly with the buckle locked in place, shall be assembled and tested as shown in Figure 3, and shall withstand the proof static load specified in Table I. There shall be no evidence of weakening of the hardware or webbing at any point. After release of the load, the release buckle shall work freely.

4.5.4.3 Type I, Class 3, Type II, Class 1 and Type II, Class 2 assemblies - The Type I, Class 3 and Type II, Class 2 assemblies shall be assembled and tested as shown in Figure 5 and the Type II, Class 1 assembly in accordance with Figure 6. With the buckles locked in place the assemblies shall withstand the loads specified in Table I without evidence of weakening of the hardware or webbing at any point.

4.5.4.4 Type III, Class 1 assembly - The assembly shall be assembled in a testing machine as specified in 4.5.3.6. A proof load as specified in Table I shall be gradually applied, at a rate of separation of the heads of one inch

MIL-R-81729(AS)

per minute (under no load). After the specified load has been applied for a period of 30 \pm 3 seconds it shall be removed.

4.5.4.5 Type III, Class 2 assembly - The assembly shall be assembled and tested as specified in 4.5.3.7. A proof load, as specified in Table I shall be gradually applied, at a rate of separation of the heads of one inch per minute (under no load). After the load has been applied for 30 \pm 3 seconds it shall be removed. There shall be no evidence of weakening or failure.

4.5.5 Quick release -

4.5.5.1 Type I, Class 1 assembly - After completion of the work loading of the assembly, the tensile load shall be reduced to 800 pounds. A force, 45 pounds or less, applied to the buckle latch at an angle of 60 degrees to the flat portion of the belt (in a direction towards the link) shall be sufficient to open the quick-release buckle.

4.5.5.2 Type I, Class 3, Type II, Class 1 and Type II, Class 2 assemblies - The assemblies shall be assembled in a testing machine as shown in Figure 5b, and a 400 pound static tension load applied. A 50 pound hand scale shall be hooked through the latch of the quick release buckle, as in Figure 5b, and the latch opened. The maximum load required to open the buckle shall not exceed the value specified in Table I.

4.5.5.3 Type I, Class 4 assembly - The assembly shall be assembled in a testing machine as indicated in Figure 4b, and a 400 pound static load applied. A 50 pound hand scale shall be hooked through the latch of the buckle as shown in Figure 4b. The latch, with the safety pin in the unlocked position, shall then be opened by applying a load through the scale perpendicular to the latch in the plane of its operation. The maximum load necessary to open the latch shall not exceed the value specified in Table I.

4.5.6 Gun barrel hydrostatic pressure (Type II, Class 2) - With the gun barrel sealed, and before the holes and slots are machined in the barrel, it shall be subjected to a 1500 psi hydrostatic pressure.

4.5.7 Working load of cable assembly (Type II, Class 2) - The swaged cable assembly of the Type II Class 2 assembly shall be subjected to and meet the requirements of a 550 pound working load when tested in accordance with the method given in MIL-T-781.

4.5.8 Firing pin sear release force (Type II, Class 2 only) - The firing pin sear of the actuating unit shall be pulled back at a rate of between 7-1/2 and 8-1/2 feet per second until the firing pin release. The force necessary to release the firing pin shall be as specified in Table I.

MIL-R-81729(AS)

4.5.9 Firing pin energy (Type II, Class 2) - An adapter conforming to Figure 10 shall be installed in the cartridge chamber of the actuator assembly. A pellet, 5/8 inch diameter by 5/16 inch long of soft copper conforming to QQ-C-502, fully annealed condition shall be fitted against the adapter. The firing pin shall be pulled back at a steady rate of 7-1/2 to 8-1/2 feet per second until the sear releases and the firing pin strikes the copper pellet. The resulting penetration shall be as specified in Table I.

4.5.10 Actuator release force (safety wired) (Type II, Class 2) - The pull force necessary to actuate the mechanism and release under a load of 400 pounds on the assembly with the gun piston arm safetied with .040 copper lockwire shall be as specified in Table I when tested as shown in Figure 11.

4.5.11 Actuator release force (without safety wire) (Type II, Class 2) - The pull force necessary to actuate the mechanism and release under a load of 400 pounds on the assembly with the gun piston arm unsafetied shall be as specified in Table I when tested as shown in Figure 11.

5. PREPARATION FOR DELIVERY

5.1 Application - The packaging, packing and marking requirements specified herein apply only to direct purchases by or direct shipment to the Government.

5.2 Packaging - Packaging shall be Level A or C, as specified (see 6.2).

5.2.1 Level A - Each assembly shall be packaged in accordance with MIL-P-116, Method III; cleaned in accordance with process C-1. Each unit shall be packed snugly in a close fitting set-up or folding paperboard box conforming to PPP-B-566 or PPP-B-676.

5.2.2 Level C - Each assembly shall be preserved and packaged in a manner that will afford the item the degree of protection necessary to prevent physical damage or deterioration during transit from the supply source to the receiving activity. The contractor's commercial practice may be utilized when it conforms to the criteria stated herein.

5.2.3 Intermediate packaging - Unless otherwise specified, twelve or twenty-four restraint system assemblies, packaged as specified in 5.2.1 shall be packaged with an intermediate fiberboard box conforming to PPP-B-636.

5.3 Packing - Packing shall be Level A, B, or C as specified (see 6.2).

MIL-R-81729(AS)

5.3.1 Level A - Restraint system assemblies packaged as specified in 5.2.1 shall be packed in overseas type cleated fiberboard, cleated plywood or wood cleated fiberboard, paper overlaid containers conforming to PPP-B-576, PPP-B-591, PPP-B-601, or PPP-B-636. The containers shall be closed and strapped in accordance with the requirements of the appendix of the applicable box specification. The gross weight of the exterior shipping container when fully packed shall not exceed approximately 200 pounds. Plywood, when used, shall conform to NN-P-530.

5.3.2 Level B - Restraint system assemblies packaged as described in 5.2.1 shall be packed in domestic type containers conforming to PPP-B-576, PPP-B-591, PPP-B-601, or PPP-B-636. The gross weight of wood or wood cleated containers shall not exceed 200 pounds.

5.3.3 Level C - Restraint system assemblies packaged as specified in 5.2.1 shall be packed in a manner to insure carrier acceptance and safe delivery at destination. Containers shall be in accordance with Uniform Freight Classification Rules or regulations of other carriers applicable to the mode of transportation.

5.4 Marking - Unit packages, and intermediate containers shall be marked in accordance with MIL-STD-129.

6. NOTES

6.1 Intended use - The restraint systems are intended for use by crew members and passengers in military aircraft, in remaining in their seats during turbulent flight or in an emergency situation.

6.2 Ordering data - Procurement documents should specify the following:

- (a) Title, number and date of this specification
- (b) Quantity, Type and Class of assembly desired
- (c) Whether first article inspection is waived (see 4.3.1)
- (d) Name and address of quality conformance inspection facility including the laboratory and Government activity responsible for conducting the inspection program (see 4.4.1.3)
- (e) Selection of applicable levels of packaging and packing (see 5.1, 5.2 and 5.3)
- (f) Name and address of the first article inspection laboratory (4.3.1).

6.3 Laboratory information - The successful bidder will be furnished with the name of the inspection laboratory, if different from the Aerospace Crew Equipment Department (see 4.4.1.3), at the time of the award. The costs of the tests and examinations on samples initially submitted from a lot, as required by 4.4.1.3 shall be borne by the Government whether the tests and examinations are

MIL-R-81729(AS)

conducted by the Aerospace Crew Equipment Department or by a laboratory selected by the Aerospace Crew Equipment Department. Samples from a rejected lot shall not be resubmitted for tests and examinations as required by 4.4.1.3 without the approval of the contracting officer. The cost of the tests and examinations on samples resubmitted from a reworked lot or from a new lot which is necessitated by the rejection of a previous lot shall be borne by the manufacturer whether the tests and examinations are conducted by the Aerospace Crew Equipment Department or a laboratory selected by the Aerospace Crew Equipment Department.

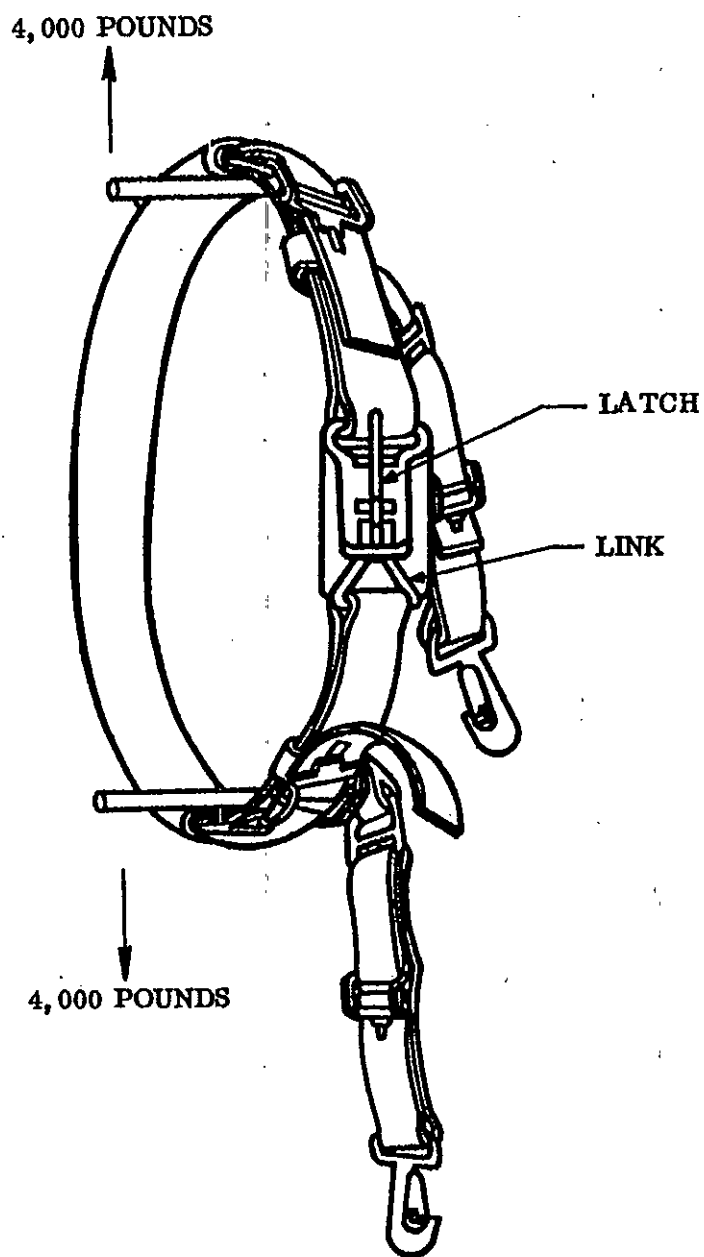

TYPE 1, CLASS 1

FIGURE 1. PROOF LOAD

MIL-R-81729(AS)

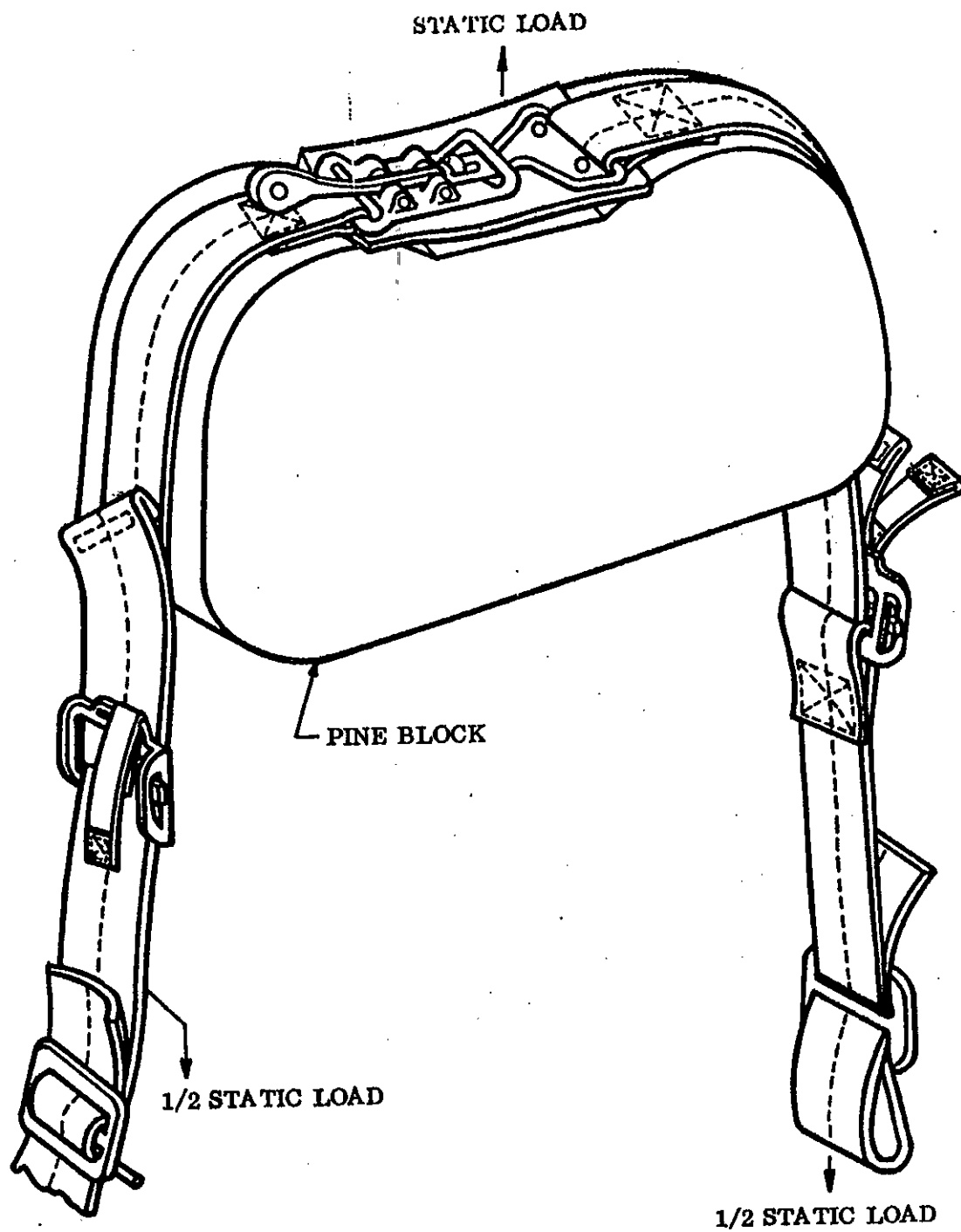

TYPE I, CLASS 2

FIGURE 3. STATIC LOADING

MIL-R-81729(AS)

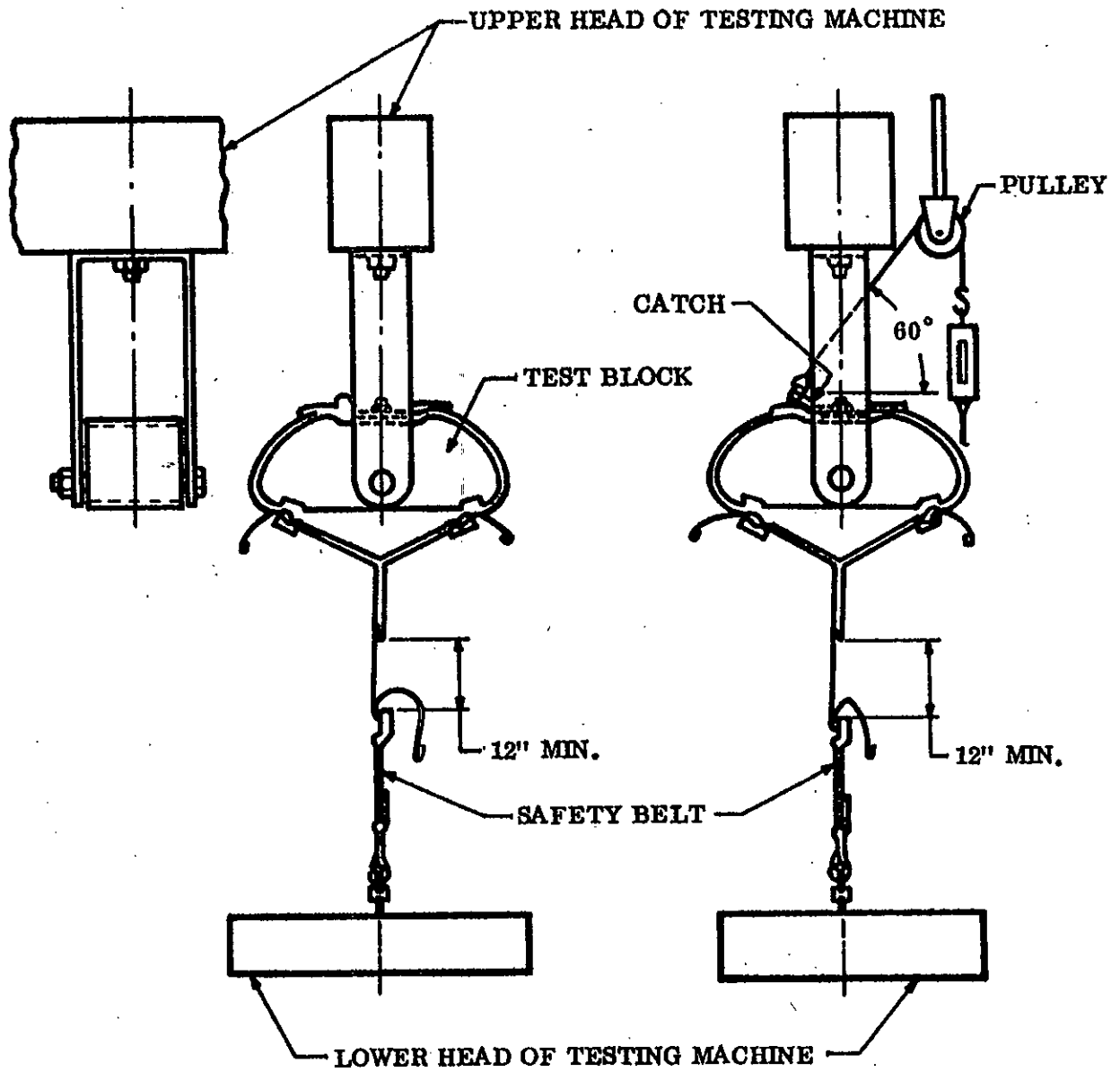

PROOF LOAD TEST

QUICK RELEASE BUCKLE -
OPERATING POSITION

FIGURE 4a

FIGURE 4b

TYPE I, CLASS 4

FIGURE 4. PROOF LOAD AND QUICK RELEASE TESTS

MIL-R-81729(AS)

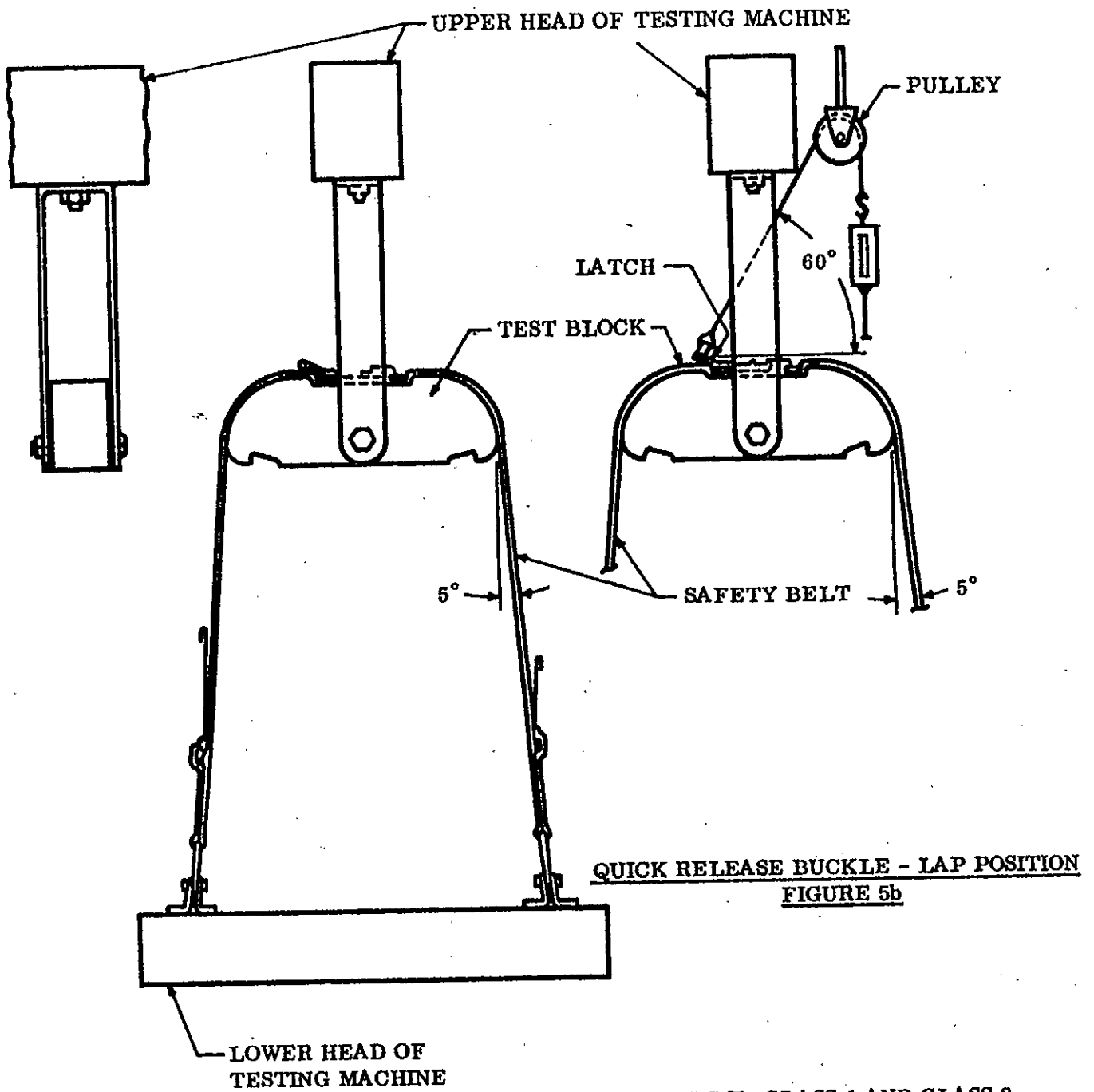

PROOF LOAD TEST
FIGURE 5a

TYPE II, CLASS 1 AND CLASS 2

FIGURE 5. PROOF LOAD AND QUICK RELEASE TESTS

MTL-R-81729(AS)

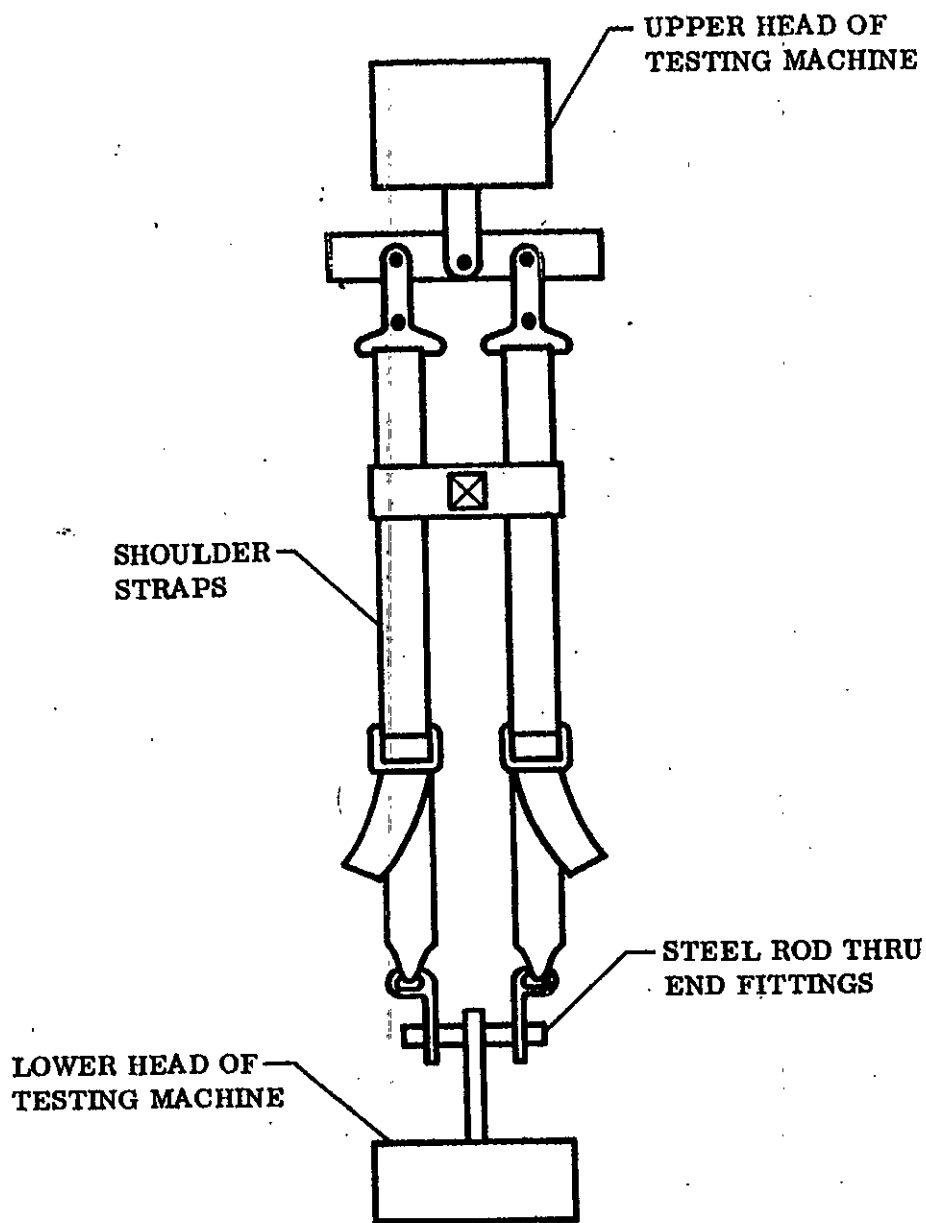

TYPE II, CLASS 1

FIGURE 6. STRENGTH TEST - SHOULDER STRAPS

MIL-R-81729(AS)

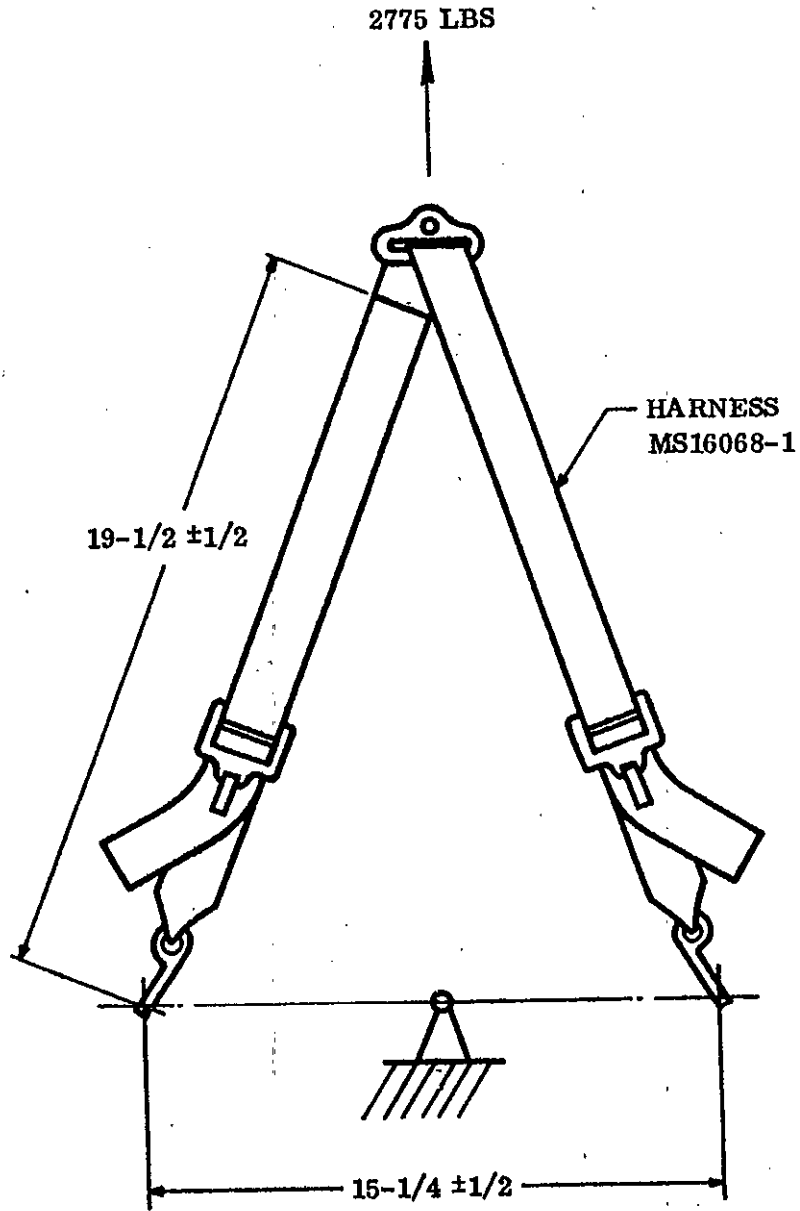

DIMENSIONS IN INCHES.

TYPE III, CLASS 1

FIGURE 7. LOADING CONFIGURATION

MTI-6-817.2'(A3)

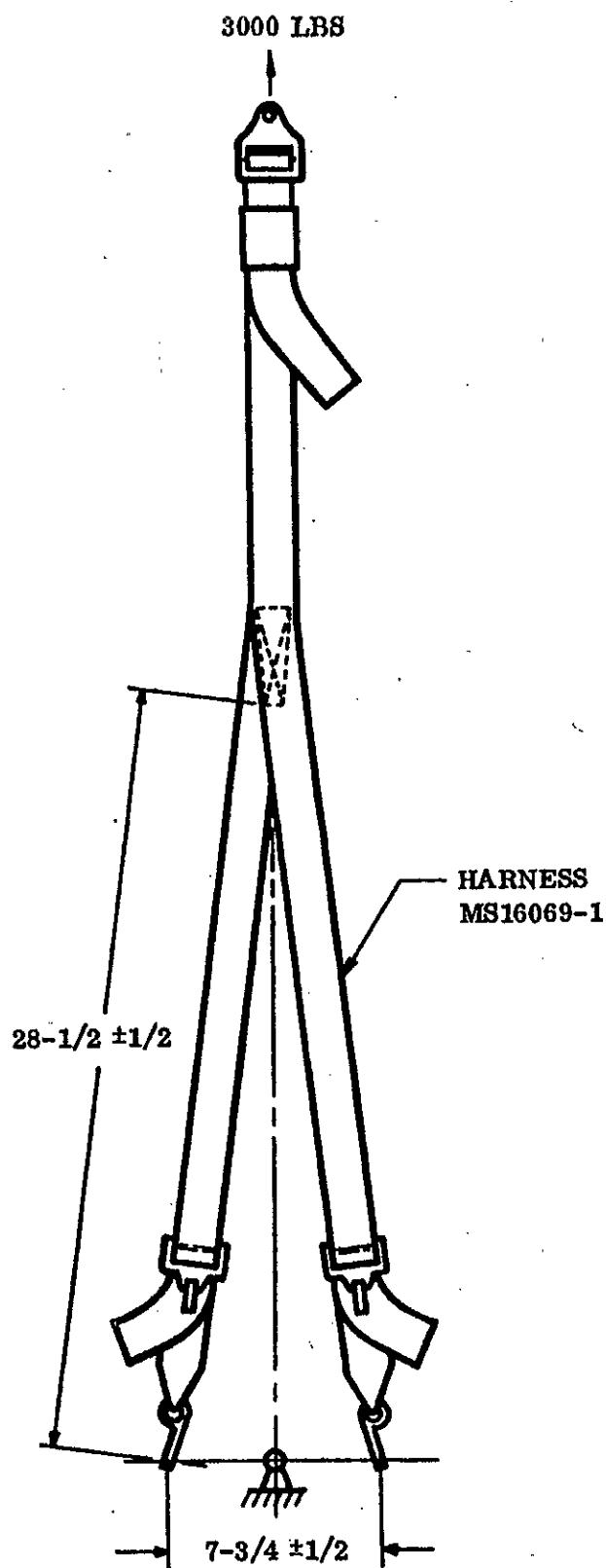

DIMENSIONS IN INCHES.

TYPE III, CLASS 2

FIGURE 8. LOADING CONFIGURATION

MIL-R-81729(AS)

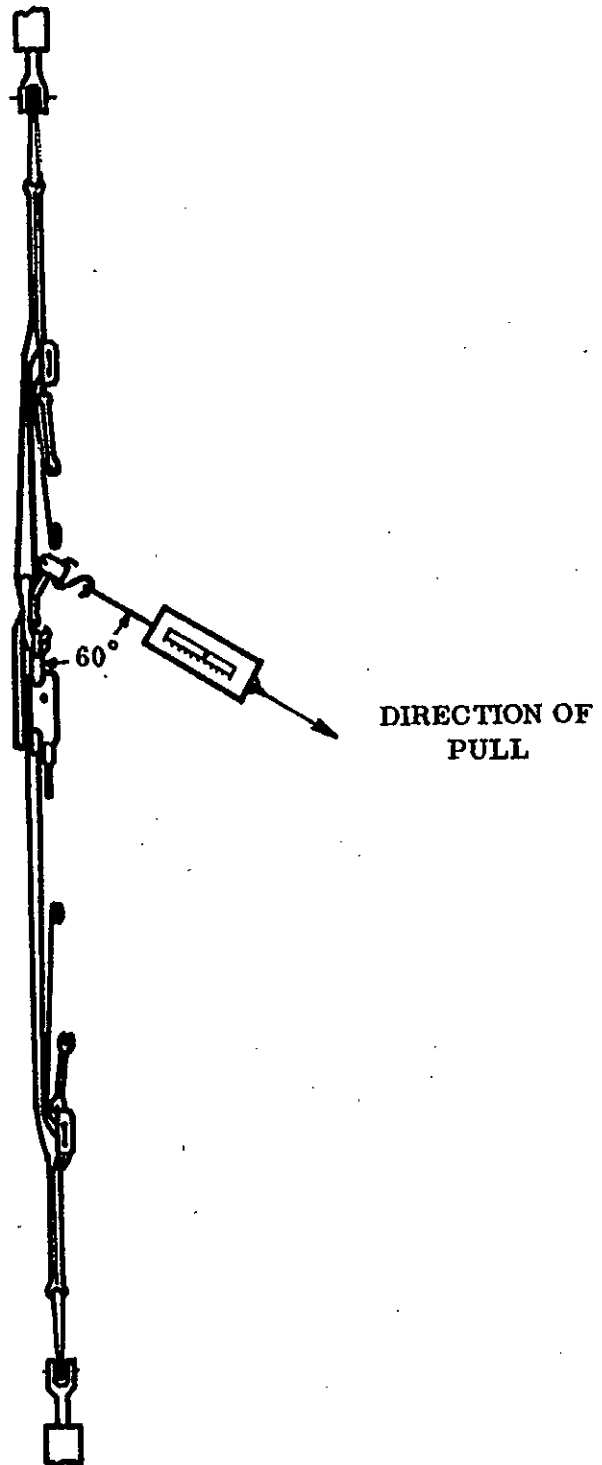

TYPE II, CLASS 1 AND CLASS 2

FIGURE 9. QUICK RELEASE BUCKLE EXTENDED POSITION

MTI-4-817.2(A)

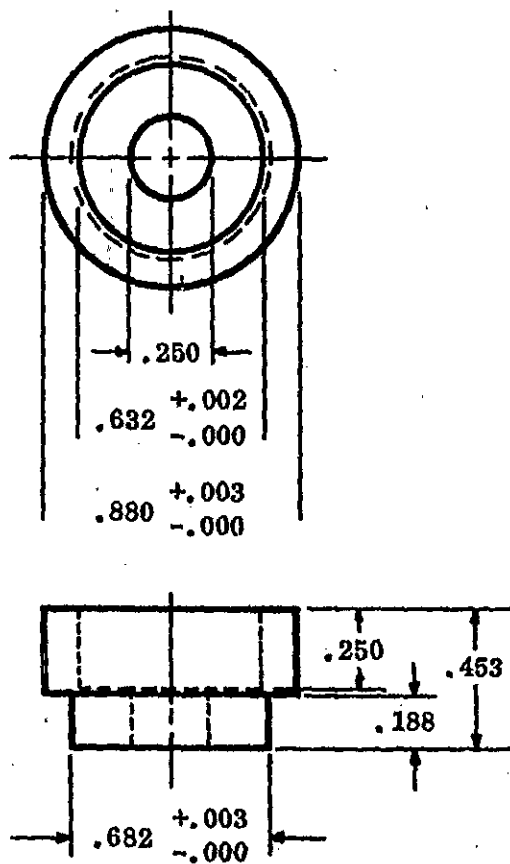

DIMENSIONS IN INCHES. UNLESS OTHERWISE SPECIFIED, TOLERANCE: $\pm .010$

TYPE II, CLASS 2

FIGURE 10. ADAPTER - FIRING PIN ENERGY TEST

MIL-R-81729(AS)

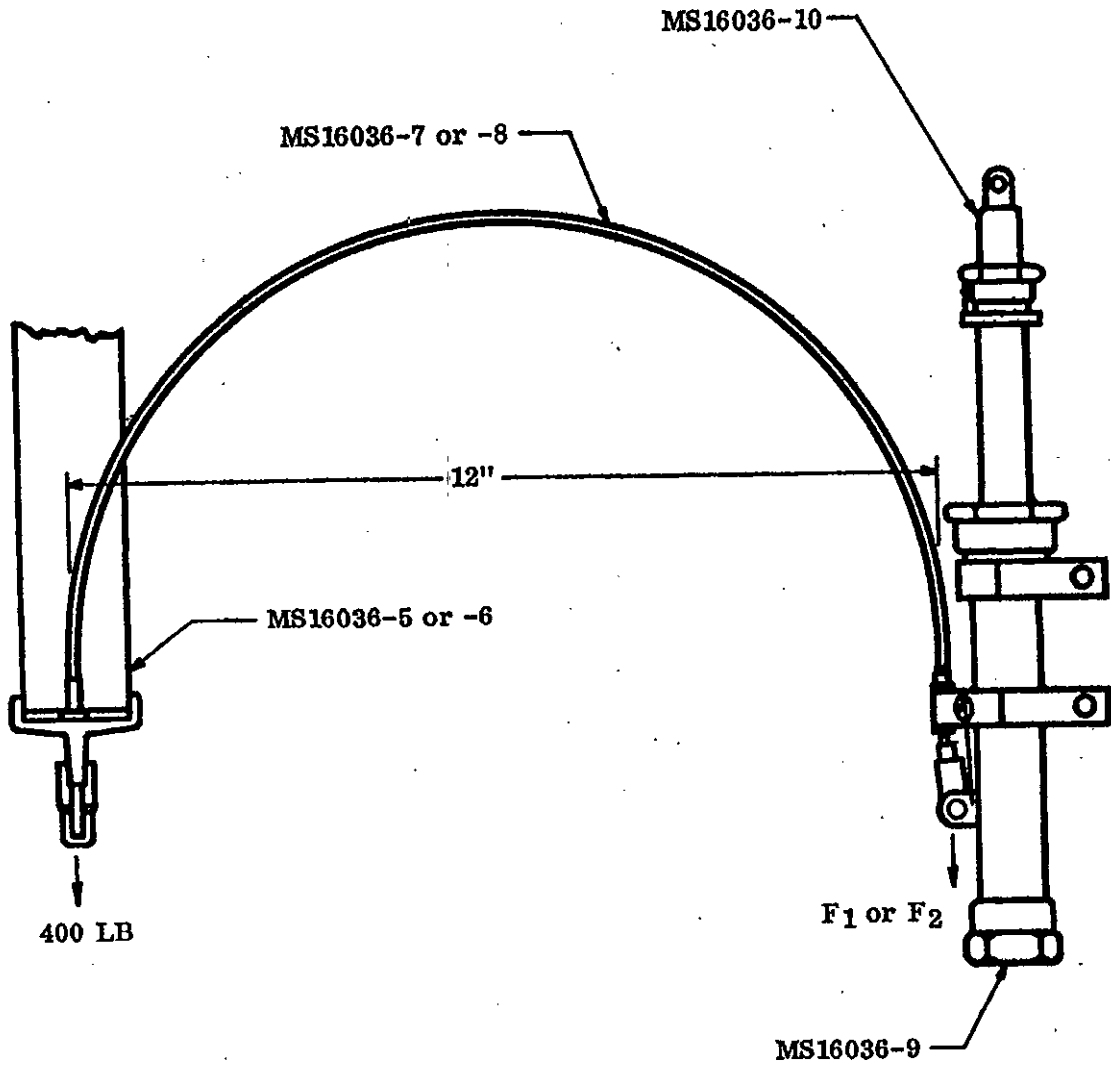

TYPE II, CLASS 2

FIGURE 11. ACTUATOR RELEASE FORCE TEST