

MIL-R-55002B(EL)

31 MAY 1963

SUPERSEDING

MIL-R-55002A(SigC)

24 JANUARY 1961

MILITARY SPECIFICATION**RADIO SET AN/VRC-24() (UNITS OF)
AND CONTROL, RADIO SET C-1439()/U****1. SCOPE**

1.1 This specification covers the following units of a vehicular mounted, amplitude-modulated radio receiving-transmitting set operating on any of 1,750 crystal-controlled channels in the frequency range of 225.0 to 399.9 megacycles (mc) (see 6.1 and 6.7).

Receiver-Transmitter, Radio RT-323
()/VRC-24

Dynamotor DY-151()/U

Case, Receiver-Transmitter CY-2557
()/VRC-24

Mounting MT-1436()/U

1.2 This specification also covers Control, Radio Set C-1439()/U, used with Radio Set AN/VRC-24().

2. APPLICABLE DOCUMENTS

2.1 The following documents, of the issue in effect on date of invitation for bids or request for proposal, form a part of this specification to the extent specified herein.

SPECIFICATIONS**FEDERAL**

T-T-871 —Twine, Cotton, Wrapping.

FF-S-103 —Setscrews.

QQ-P-416 —Plating, Cadmium (Electrodeposited).

QQ-S-571 —Solder: Lead Alloy, Tin Lead Alloy, and Tin Alloy; Flux Cored Ribbon

and Wire, and Solid Form.

QQ-S-781 —Strapping, Flat; Steel.

QQ-Z-325 —Zinc Coating, Electrodeposited, Requirements for.

UU-T-111 —Tape; Paper, Gummed (Sealing and Securing).

PPP-B-566 —Boxes, Folding, Paperboard.

PPP-B-601 —Boxes, Wood, Cleated Plywood.

PPP-B-621 —Boxes, Wood, Nailed and Lock-Corner.

PPP-B-636 —Boxes, Fiber.

PPP-C-843 —Cushioning Material, Cellulosic.

PPP-F-320 —Fiberboard, Sheet, Stock and Cut Shapes.

PP-P-291 —Paperboard, Wrapping, Cushioning.

PP-T-76 —Tape, Pressure-Sensitive, Adhesive, Paper, Water-Resistant.

MILITARY

MIL-E-1 —Electron Tubes and Crystal Rectifiers.

MIL-C-17 —Cables, Radio Frequency, Coaxial, Dual Coaxial, Twin Conductor, and Twin Lead.

MIL-E-75 —Electron Tubes, Packaging, Packing and Con-

FSC 5820

MIL-R-55002B(EL)

- tainer Marking for:
General Specification
for.
- MIL-P-116** —Preservation, Methods
of.
- MIL-B-117** —Bags, Interior Packag-
ing.
- MIL-V-173** —Varnish, Moisture and
Fungus Resistant, for
the Treatment of
Communications,
Electronic, and
Associated Electrical
Equipment.
- MIL-C-490** —Cleaning and Prepara-
tion of Ferrous and
Zinc Coated Surfaces
for Organic Protec-
tive Coatings.
- MIL-I-631** —Insulation, Electrical,
Synthetic-Resin Com-
position, Nonrigid.
- MIL-T-713** —Twine and Tape, Lacing
and Tying (For Use
in Electrical and Elec-
tronic Equipment).
- MIL-S-901** —Shockproof Equipment,
Class HI (High-Im-
pact), Shipboard
Installation, Tests
for.
- MIL-S-971** —Screws, Wood.
- MIL-I-3158** —Insulation Tape, Elec-
trical, Glass-Fiber
(Resin-Filled); and
Cord, Fibrous-Glass.
- MIL-I-3190** —Insulation Sleeving,
Electrical, Flexible,
Treated.
- MIL-C-3702** —Cable, Power, Electri-
cal, Ignition, High
Tension.
- MIL-C-3885** —Cable Assemblies and
Cord Assemblies,
Electrical (for Use in
Electronic, Communi-
cation, and Associ-
ated Electrical
Equipment).
- MIL-W-6858** —Welding, Resistance,
Aluminum, Magne-
sium, Nonhardening
Steels or Alloys,
Nickel Alloys, Heat-
Resisting Alloys, and
Titanium Alloys,
Spot and Seam.
- MIL-I-7444** —Insulation Sleeving,
Electrical, Flexible.
- MIL-I-7798** —Insulation Tape, Elec-
trical, Pressure-
Sensitive Adhesive,
Plastic.
- MIL-B-7883** —Brazing of Steels, Cop-
per, Copper Alloys,
and Nickel Alloys.
- MIL-M-10578** —Metal Conditioner and
Rust Remover (Phos-
phoric Acid Base).
- MIL-I-11748** —Interference Reduction
for Electrical Equip-
ment.
- MIL-M-13231** —Marking of Electronic
Items.
- MIL-F-14072** —Finishes for Ground
Signal Equipment.
- MIL-F-14256** —Flux, Soldering, Liquid
(Rosin Base).
- MIL-I-18057** —Insulation Sleeving,
Electrical, Flexible,
Glass Fiber, Silicone
Rubber Treated.
- MIL-S-19500** —Semiconductor Devices,
General Specification
for.
- MIL-N-25027** —Nut, Self-Locking, 250°
F., 500° F., and 800°
F.

STANDARDS**MILITARY**

- MIL-STD-22** —Welded-Joint Designs.
- MIL-STD-105** —Sampling Procedures
and Tables for
Inspection by
Attributes.
- MIL-STD-129** —Marking for Shipment
and Storage.

MIL-R-55002B(EL)

- MIL-STD-169—Extreme-Temperature Cycle.
- MIL-STD-170—Moisture Resistance Test Cycle for Ground Signal Equipment.
- MIL-STD-200—Electron Tubes.
- MIL-STD-252—Wired Equipment, Classification of Visual and Mechanical Defects.
- MIL-STD-681—Identification Coding and Application of Hookup Wire.
- MIL-STD-701—Preferred and Guidance List of Transistors.
- MS33540 —Safety Wiring, General Practices for.
- MS35335 —Washer, Lock, Flat, External Tooth.
- MS35338 —Washer, Lock, Split, Helical, Medium Series.
- MS75027 —Cable-Cord, Standard Lengths and Standard Tolerances for Communication, Power and Radio Frequency Cable and Cord Assemblies.

DRAWINGS**SIGNAL CORPS**

- SC-A-46420 —Fasteners.
- SC-A-46439 —List of Accessories for Package Tester.
- SC-A-46570 —Materials and Processes for Printed Wiring Assembly.
- SC-GL-55712 —Drawing and Gage Point List for Receiver-Transmitter, Radio RT-323()/VRC-24.
- SC-GL-55715 —Drawing and Gage Point List for Case, Receiver-Transmitter CY-2557 () /VRC-24.

- SC-GL-57716 —Drawing and Gage Point List for Mounting MT-1436 ()/U.
- SC-GL-57719 —Drawing and Gage Point List for Radio Set AN/VRC-24().
- SC-B-61578 —Grounding to Chassis.
- SC-DL-343840 —Drawing and Data List for Radio Receiver-Transmitter RT-323()/VRC-24.
- SC-DL-344929 —Drawing and Data List for Dynamotor DY-151()/U.
- SC-DL-344948 —Drawing and Data List for Mounting MT-1436()/U.
- SC-DL-344997 —Drawing and Data List for Receiver-Transmitter Case CY-2557()/VRC-24.
- SC-DL-345073 —Drawing and Data List for Radio Set Control C-1439()/U.

(Copies of specifications, standards, drawings, and publications required by suppliers in connection with specific procurement functions should be obtained from the procuring activity or as directed by the contracting officer. Both the title and number or symbol should be stipulated when requesting copies.)

2.2 Other publication. The following document forms a part of this specification to the extent specified herein. Unless otherwise indicated, the issue in effect on date of invitation for bids, or request for proposal, shall apply:

NATIONAL BUREAU OF STANDARDS

Handbook H28—Screw-Thread Standards for Federal Services.

(Application for copies should be addressed to the Superintendent of Documents, Government Printing Office, Washington, D.C.)

3. REQUIREMENTS

3.1 Description. Two-way type A3 voice

MIL-R-55002B(EL)

communication can be conducted on any of 19 preset channels, after a 5-second channel selection time, using Microphone M-29()/U and Dynamic Loudspeaker LS-166()/U. The AN/VRC-24() may be used in conjunction with Ciphony Equipment TSEC/KY-8. The preset channels may be selected, the set turned on and off, and volume and squelch levels adjusted from a remote site by using Radio Set Control C-1439()/U. Channel spacing is 100 kilocycles (kc); presetting a channel requires approximately 10 seconds. Nominal transmitter radio-frequency (rf) output is 16 watts (w).

3.2 Construction. The units listed shall be constructed in accordance with the applicable drawings.

Unit	Drawing
RT-323()/VRC-24	SC-DL-343840
DY-151()/U	SC-DL-344929
MT-1436()/U	SC-DL-344948
CY-2557()/VRC-24	SC-DL-344997
C-1439()/U	SC-DL-345078

3.3 Preproduction samples. The contractor shall furnish two (2) preproduction samples of the equipment for approval, if required by the invitation for bids and contract. (See 4.3 and 6.2(e)(1).)

3.4 Parts, materials, and processes.

3.4.1 Cable assemblies (see 4.4). The length of electrical cable assemblies shall conform to Military Standard MS75027 or as specified on the drawings. Power and audio-frequency (af) cable and cord assemblies used for voltages up to and including 600 volts alternating-current (ac) or corresponding direct-current (dc) shall conform to all requirements of Specification MIL-C-3885. Cable assemblies used for over 600 volts ac or equivalent dc shall be subject to approval by the contracting officer. Where applicable, high-voltage cable shall conform to Specification MIL-C-3702. Radio frequency coaxial cables shall be in accordance with Specification MIL-C-17.

3.4.2 Finish, protective (see 4.4). The equipment shall be finished in accordance

with Specification MIL-F-14072 and the equipment drawings. The final paint film on type I surfaces shall be green color (olive drab), semigloss enamel matching a color chip provided by the procuring agency. (See 6.3.)

3.4.3 Plastic materials and parts. Where not machined, plastic materials and parts shall have the original smooth or polished surfaces. Surfaces that have been sawed, cut, punched, or otherwise machined shall be as smooth as practicable, in accordance with good manufacturing practice for the intended application.

3.4.4 Cleaning.

3.4.4.1 Parts. After fabrication, parts shall be cleaned in accordance with good commercial practice, or as specified in an applicable document. Cleaning processes shall have no deleterious effect. Corrosive material shall be removed completely before the parts are mounted on chassis, panels, etc.

3.4.4.2 Units. After assembly, units shall be cleaned thoroughly and shall be free from particles of solder, flux, and other foreign material. In addition, when necessary, such cleaning shall also be performed before final assembly of the units.

3.4.5 Marking.

3.4.5.1 Conformance. Marking shall conform to Specification MIL-M-13231. (See 4.4.) Front panel marking shall be group I as described in that specification.

3.4.5.2 Visibility of markings. Wherever practicable, parts shall be so mounted that their identification markings will be readily visible with minimum disassembly of the equipment.

3.4.5.3 Serial numbers. The following items shall have serial numbers:

Receiver-Transmitter, Radio
RT-323()/VRC-24
Dynamotor DY-151()/U
Mounting MT-1436()/U

MIL-R-55002B(EL)

Case, Receiver-Transmitter
CY-2557()/VRC-24
Control, Radio Set C-1439()/U

3.4.6 Riveting. Thickness of countersunk metal which accepts the heads of flush rivets shall be not less than the height of the rivet heads. After riveting, the joints shall be tight, the joined parts shall be undamaged, and the rivet heads shall be properly seated and tight against their bearing surfaces.

3.4.7 Securing of parts.

3.4.7.1 Mounting components. Brackets, lugs, flanges, inserts, bolts, and other mounting arrangements shall be such as to retain items securely when subjected to specified service conditions. Parts shall be so mounted that loosening, wear of mounting arrangements, or permanent separation of parts will not occur when the items in which they are used are subjected to specified service conditions. Any permanent deformation resulting from the tests shall not cause degradation of performance below full specification requirements. When practicable, friction between mating surfaces shall not be employed as the sole means of preventing fixed parts from rotating. Parts shall be secured in such manner that failure of a single rivet or screw will not free the part completely.

3.4.7.2 Securing of parts by threaded fasteners. Securing of parts by threaded fasteners to hard material, or to soft material, (aluminum, magnesium, zinc, plastic, etc.), except wood, shall conform to the drawings. Except as specified therein, a flatwasher shall be used between any screwhead and soft material unless the shape of the head is such that the flatwasher is unnecessary. Nylok or other screws with plastic devices, and Loctite or similar sealants, shall not be subjected to temperatures in excess of 250° F. (as during baking of paint). Loctite or similar sealants shall not be used where the connection must be electrically conductive; where used, such materials shall be applied in accordance with the manufacturer's instructions.

3.4.7.3 Brittle material. Brittle castings, or parts made of ceramic or other brittle material, shall not be over-constrained by the means used to secure them. Not more than three points of contact shall be used between the brittle part and the mounting surface, unless the mating faces are accurately machined. Mounting washers of suitable plastic, rubber, or soft copper having slight compressibility shall be provided to prevent breakage or cracking of the parts. Lead washers shall not be used. Threaded holes in ceramic material shall not be employed for assembly or mounting of parts.

3.4.7.4 Safety wiring and cotter pins. Application of safety wiring and cotter pins shall conform to Standard MS33540.

3.4.8 Brazing. Brazing of steels, copper, copper alloys, and nickel alloys shall conform to Specification MIL-B-7883.

3.4.9 Soldering.

3.4.9.1 Solder. Solder shall conform to Specification QQ-S-571. For soldering electrical connections, composition Sn60, Type AR or S, shall be used for general purposes; and composition Sn62 or Sn63, Type AD or S, for special purposes. When type S solder is used for soldering electrical connections, the flux shall conform to Specification MIL-F-14256.

3.4.9.2 Acid or acid salts. No acid or acid salts shall be used in preparation for or during soldering; however, exception is permitted for preliminary tinning of electrical connections and for tinning or soldering of mechanical joints not used to complete electrical circuits, but in no case shall acid or acid salts be used where they can come in contact with insulation material. Where acid or acid salts are used, as permitted above, they shall be completely neutralized and removed immediately after use.

3.4.9.3 Process. There shall be no sharp points or rough surfaces resulting from insufficient heating. The solder shall feather out to a thin edge, indicating proper flowing and wetting actions, and shall not be crystal-

MIL-R-55002B(EL)

lized, overheated, or underheated. The minimum necessary amount of flux and solder shall be used for electrical connections. Any means employed to remove an unavoidable excess of flux shall not incur the risk of loose particles of flux, brush bristles, or other foreign material remaining in the equipment; flux being spread over a large area; or damage to the equipment. Insulation material that has been subjected to heating during the soldering operation shall be undamaged and parts fastened thereto shall not have become loosened.

3.4.10 Tropicalization of material. Material shall be treated as follows:

3.4.10.1 Treating materials. Treating materials containing a mercury-bearing fungicide shall not be used. The contractor shall determine that the treating material is compatible with the material or surface to be treated. Selection of treating materials shall be such that any increase in flammability of treated material will be held to the practical minimum.

3.4.10.2 Toxicity. Treating materials shall cause no skin irritation or other injury to personnel handling the treated material during fabrication, transportation, operation, or maintenance of the equipment or during use of the finished items when used for the purpose intended.

3.4.10.3 Flexibility. Treatment shall not affect the flexibility of treated materials to the extent that the equipment may fail to meet specified requirements when subjected to specified service conditions.

3.4.10.4 Statement of treatment. The contractor shall submit for approval, to the contracting officer, a statement describing in detail the materials to be treated and the treating materials and processes that he proposes to use (see 6.2(j)).

3.4.11 Welding. Wherever practicable, welded joints shall conform to Standard MIL-STD-22 and shall be such that grinding on the finished weld will be unnecessary. Spot, stitch, and seam welds shall conform

to Specification MIL-W-6858. Spot or other intermittent welds in aluminum or magnesium shall be limited to lightly stressed, noncritical structures. When spot or other intermittent welds are used to hold a part, the number of welds shall be at least two.

3.4.11.1 Cleaning prior to welding. Surfaces to be welded shall be cleaned in accordance with good commercial practice and shall be free from rust, scale, paint, grease, and other foreign material.

3.4.11.2 Process. Preheating shall be employed where distortion is likely to result from welding. Welds shall have thorough penetration and good fusion and shall be free from scabs, blisters, abnormal pock marks, cracks, voids, slag inclusions, and other harmful defects. Where undesirable internal stresses are likely to result from welding, welded items shall be stress-relieved. Inert-gas-shielded arc welding shall be used, when practicable, for welding of aluminum, magnesium, or stainless steel.

3.4.11.3 Cleaning after welding. Welded assemblies shall be cleaned to remove rust, scale, oxidation products, and excess flux by sandblasting, wire brushing, or other suitable means. Prior to painting, steel parts that have been arc welded or acetylene welded shall, in addition, be subjected to vat passivation or a phosphoric acid etch in accordance with Specification MIL-M-10578. Acid used for cleaning shall be completely neutralized and removed.

3.4.12 Wiring and cabling. Wiring and cabling shall be neat and sturdy. Wiring instructions on drawings take precedence over the paragraphs below.

3.4.12.1 Cabling. Insulated wires shall be formed into cables except where operation of the equipment would be adversely affected thereby or where it is physically impracticable as in the case where the resulting cables would be excessively large and would interfere with operation or maintenance. The cabling of wires shall be effected by ~~wire~~ or twine conforming to Specification MIL-T-

MIL-R-55002B(EL)

713 or tape conforming to Specification MIL-I-7798, however, cord conforming to Specification MIL-I-3158 shall be used where resistance to heat or chemicals is essential. Individual conductors thus secured shall lie essentially parallel; however; this does not prohibit the use of twisted pairs.

3.4.12.2 Slack. Wires and cables shall be as short as practical except that sufficient slack shall be provided for the following purposes:

- (a) To prevent undue stress on cable forms, wires, and connections, including connections to resiliently supported parts.
- (b) To enable parts to be removed and replaced during servicing without disconnecting other parts.
- (c) To provide for at least two replacements of the part to which the wire or cable is connected, except for certain radio-frequency leads which must be as short as possible for electrical reasons.
- (d) To ensure freedom of motion of lugs or terminals normally intended to have some degree of movement (for example, floating contacts on electron tube sockets).
- (e) To facilitate field repair of broken or cut wires.
- (f) To prevent chafing or breaking of individual wires due to repeated flexing of hinged parts.

3.4.12.3 Protection. Wires and cables shall be so placed and protected as to avoid contact, under specified service conditions, with rough or irregular surfaces or sharp edges. Wires shall not be bent sharply where they enter insulation material. Where wires run through holes in metal partitions, shields, or similar items less than $\frac{1}{8}$ inch in thickness, the wires shall be protected by suitable grommets or bushings. Where wires run through holes in metal $\frac{1}{8}$ inch in thickness or greater, the wires shall be protected by grommets or bushings or shall have the edges of the holes rounded to a minimum radius of $\frac{1}{16}$ inch.

3.4.12.4 Support. Wire and cable shall be

properly supported and secured, to prevent undue stress on the conductors and terminals and undue change in position of the wire or cable (i) during and after subjection of the equipment to specified service conditions or (ii) after service or repair of the equipment in a normal manner. (Note: When shielding of wire or cable is unprotected by an outer insulation, adequate support is necessary to prevent the shielding from coming in contact with exposed terminals or conductors.) Twine or tape shall not be used for securing wire and cable.

3.4.12.5 Clearance. Clearance between wires or cables, and parts such as electron tubes, resistors, and dynamotors, shall be provided to avoid deterioration of the wires or cables because of the heat dissipated by such parts when the equipment is subjected to specified service conditions. Clearance between solder connections or bare conductors, on terminal boards, relays, or other parts, shall be such that no accidental contact can occur between adjacent connections when subjected to specified service conditions.

3.4.12.6 Splicing. Wires in a continuous run between two terminals shall not be spliced during the wiring operation.

3.4.12.7 Insulating sleeving. Insulating sleeving shall not be used unless specified for a particular application or specifically approved by the contracting officer. Approval will not be granted when other means of insulation are practicable. If insulating sleeving is used, it shall conform to Specification MIL-I-631, MIL-I-3190, MIL-I-7444, or MIL-I-18057, as applicable.

3.4.12.8 Inductive and capacitive effects. Wires and cables shall be so located that inductive and capacitive effects, unless used as a design feature, will be the minimum practicable.

3.4.12.9 Connections. Before being soldered to terminal lugs or fixed terminals, wires shall be mechanically secured so that the connections are not dependent for

MIL-R-55002B(EL)

strength on solder alone. Where practicable, wires soldered to fixed terminals shall be looped at least one-half turn but not more than three-quarters turn around the terminal before soldering. Bared ends of wire leads to be terminated in solder-type terminal lugs shall be tinned, silverplated, or lead-alloy coated. Electrical connections shall not be made by clamping between a metallic and nonmetallic material. Welded electrical connections shall not be used where it may be necessary to disconnect and reconnect the circuit during servicing. Fraying of textile ends of wires shall be prevented mechanically or by application of varnish conforming to Specification MIL-V-173. No varnish, lacquer, inspection paint, or other coating shall be applied to completed electrical connections.

3.4.12.10 Grounding. Ground connection to shields and to other mechanical parts, except the chassis or frame, shall not be made to complete electrical circuits but only to eliminate high-potential ac points. Intermediate-frequency (i-f) transformers, however, may be grounded through their cases if other means of grounding are impracticable.

3.4.12.11 Grounding to chassis. Grounding to chassis shall conform to Drawing SC-B-61578.

3.4.12.12 Wire and cable shielding. Wire or cable shielding shall be grounded to the chassis or frame of the equipment. When the wire or cable terminates in a connector, the shielding shall be connected through a pin of the connector, unless it is a coaxial type or another type where this procedure is impractical. Shielding shall end at a sufficient distance from exposed conductors to insure against shorting or arcing between the conductor and the shielding. Where practicable, shielding shall be terminated by a crimp-type ferrule or by soldering at the end of the shielding.

3.4.12.13 Identification of wiring. Wiring shall be identified by color-coding or, if approved by the contracting officer, may be identified by other means such as marking of terminals at both ends of each lead. Color-

coding for chassis wiring shall be system I or II, conforming to Standard MIL-STD-681, as applicable, except that coding specified in present drawings shall not be changed without permission of the contracting officer.

3.4.13 Screws, other threaded devices, and related parts.

3.4.13.1 Form and fit. Unless otherwise specified, screw threads shall conform to Handbook H28; the Unified Thread Form and Series shall be class 2A or 2B fit, and the American National Thread Series shall be class 2 fit.

3.4.13.2 Material. Where permitted by design considerations, and unless otherwise specified, screws, other threaded devices, and related parts shall be of carbon steel having cadmium plating, type II, class 3, conforming to Specification QQ-P-416; of steel having zinc plating, type II, class 3, conforming to Specification QQ-Z-325; or of corrosion resistant steel, passivated.

3.4.13.3 Machine screws, cap screws, and washers. Unless otherwise specified, machine screws, cap screws, and washers shall be selected from Drawing SC-A-46420.

3.4.13.4 Machine screws. Unless otherwise specified, machine screws shall be no smaller than No. 6 (0.138-inch nominal size) and shall have drilled-fillister or pan heads. Flat-head screws shall not be used in sheet or thin material unless the thickness of the material is at least $1\frac{1}{2}$ times the height of the screw head. The screw heads shall be completely seated in the material.

3.4.13.5 Lockwashers. Unless otherwise specified, lockwashers shall be split, helical type conforming to Standard MS35338 with "cadmium or zinc, optional" finish as shown thereon. Tooth-type lockwashers shall be steel flat external-tooth-type conforming to Standard MS35335 with "cadmium or zinc, optional" finish as shown thereon and shall be used only for grounding and in the suppression of electrical interference.

3.4.13.6 Self-tapping screws. Thread-form-

MIL-R-55002B(EL)

ing screws shall not be used. Thread-cutting screws shall be used only if construction is improved thereby and only in places where the screws will not require loosening or removal during operation or maintenance. In addition, their use shall be subject to approval by the contracting officer. Chips formed in through holes by thread-cutting screws shall be removed.

3.4.13.7 Setscrews. Setscrews shall be used only where uniquely required by design of the equipment. Setscrews shall be type III (hexagon socket) conforming to Specification FF-S-103; however, setscrews used on control knobs may be type II (slotted). Setscrews shall be style 2 (cone point) or style 4 (cup point) and preferably shall be No. 6, 8, or 10. Where two setscrews are used, the angle between their major axes shall be not less than 90 degrees and not more than 120 degrees. The engaging surface for style 2 setscrews shall be suitably countersunk to receive the point. When one or more style 4 setscrews are used and the part is not adjustable in angular relationship to the shaft on which it is secured, one setscrew shall bear on a flat surface.

3.4.13.8 Wood screws. Wood screws, when used, shall conform to Specification MIL-S-971. Steel wood screws shall be given grade I treatment (phosphate coating) conforming to Specification MIL-C-490, or the finish specified in 4.13.2.

3.4.13.9 Anchor and clinch nuts and nut plates. Where practicable, anchor or clinch nuts or nut plates shall be used for threaded engagement of corresponding machine-screw nuts in sizes No. 12 and smaller and semifinished hexagon regular nuts in sizes $\frac{1}{4}$ inch and larger, as shown in Handbook H28.

3.4.13.10 Nut, self-locking. Self-locking nuts shall conform to Specification MIL-N-25027. In no case shall locknuts containing plastic inserts be subjected to temperatures in excess of 250° F. (as during baking of paint.)

3.4.13.11 Thread engagement and extension. The length of thread engagement for

tapped holes in steel or hard brass shall at least equal the nominal thickness of corresponding machine-screw nuts in sizes No. 12 and smaller and semifinished hexagon regular nuts in sizes $\frac{1}{4}$ inch and larger, as shown in Handbook H28. Thread engagement for tapped holes in aluminum, magnesium, or other soft material shall be at least 50 percent greater than the thread engagement specified for steel or hard brass. Where permitted by design of the equipment, screws and bolts shall extend at least $1\frac{1}{2}$ threads beyond the nut, but no more than $1\frac{1}{2}$ threads plus $\frac{1}{8}$ inch for screws up to 1 inch in length and $1\frac{1}{2}$ threads plus $\frac{1}{4}$ inch for screws over 1 inch in length.

3.4.13.12 Torque - measuring devices. Threaded parts of steel shall be tightened to the torque value shown in table I. Threaded parts of other size or material shall be tightened to a suitable design value established by the contractor for the particular application. For critically stressed applications, the torque for tightening threaded parts shall be controlled by use of torque measuring or controlling devices.

TABLE I. *Torque for tightening steel threaded parts*

Thread	Torque (lb-in)
6-32	7 to 9
8-32	14 to 18
10-24	19 to 23
10-32	25 to 30
12-24	32 to 39

3.4.13.13 Anti-seize compound. Anti-seize compound shall be used to prevent seizing of threads where the threaded surface is aluminum or magnesium alloy. The compound shall be made of equal parts by weight of petrolatum and zinc dust—200 mesh-fine.

3.4.13.14 Adjustment screws. Adjustment screws and similar devices shall be prevented from rotating except when being adjusted. Loctite sealant, as made by the American Sealants Company, Hartford 6, Connecticut, or equal, may be used for this purpose, if it will not be subjected to temperatures in excess of 250° F. (as during baking of paint), or if it cannot inadvertently enter a space

MIL-R-55002B(EL)

where it can harden and interfere with operation of the device. Loctite or similar sealants shall be applied in accordance with manufacturer's instructions.

3.4.14 Tubes, electron; and semiconductors, transistor and diode. Except as otherwise provided by Standards MIL-STD-200 and MIL-STD-701, these electron devices (tubes and semiconductors) shall conform to Specifications MIL-E-1 and MIL-S-19500.

3.4.14.1 Choice, use and application. Except as otherwise specified in (a) and (b) below, the choice, use, and application of these electron devices shall conform to Standards MIL-STD-200 and MIL-STD-701:

- (a) When substitution of a preferred or guidance type of electron device for a type required by the equipment specification would degrade equipment performance or ruggedness below specified requirements, pertinent data shall be furnished to the contracting officer, to justify retaining the type required by the equipment specification.
- (b) When the foregoing standards require modification of equipment circuitry, the modification shall be subject to prior approval by the contracting officer.

3.4.14.2 Circuit location. The electron devices and nonlinear parts furnished in equipment on contract shall be the individual devices used when the equipment was inspected for acceptance and, unless separate packaging of the devices is specified, shall remain in the respective locations occupied during the inspection.

3.4.15 Adjustment and repair. The equipment shall be so constructed that parts, terminals, wiring, etc., are accessible for circuit checking, adjustment, maintenance, repair, and replacement with minimum disturbance to other parts and wiring. After normal maintenance and repair, the equipment shall meet specified performance requirements.

3.4.16 Fabric and thread. The color of any required fabric shall be Olive-Drab No. 7. The color of thread shall match shade S-1 of the United States Army Standard Color Card for Official Standardization Shades of Sewing Thread. (See 6.8.) Fabric and thread shall be preshrunk, or allowance shall be made for shrinkage, in order to provide for satisfactory fit of finished items both before and after they are immersed in water and then dried.

3.4.17 Interchangeability. Like units, assemblies, subassemblies, and replaceable parts shall be physically and functionally interchangeable, without modification of such items or of the equipment. (See 4.18.) Individual items shall not be hand-picked for fit or performance; however, matched pairs or sets, when permitted, may be interchangeable as such. Reliance shall not be placed on any unspecified dimension, rating, characteristic, etc.

3.4.18 Controls and rotating components. Controls shall conform to the following requirements:

3.4.18.1 Effect of vibration, bounce and shock. Controls shall maintain their setting when the items in which they are used are subjected to specified operating service conditions.

3.4.18.2 Mechanical operation. Play and backlash shall not cause poor contact or inaccurate setting. Controls shall operate freely and smoothly, and shall be lubricated when lubrication does not interfere with operation.

3.4.18.3 Locking devices. Locking devices shall be capable of retaining controls in any given setting within the range of the control. The locking and unlocking action shall be easily accomplished and shall not affect the setting of the control. When in the unlocked position, the locking device shall not interfere with the normal operation of the control. Where vernier controls are used, the locking device shall operate on both main and vernier controls if necessary to prevent damage.

MIL-R-55002B(EL)

3.4.18.4 Tuning dial stability. Friction in the tuning dial mechanism shall be sufficient to maintain the tuning knob in any position over the operating range of the mechanism.

3.4.18.5 Gears and cams. Gears shall be properly aligned and meshed, and shall operate without interference, tight spots, or other irregularities.

3.4.19 Printed wiring assemblies. Printed wiring assemblies shall be processed and fabricated according to SC-A-46570. (See 4.4).

3.5 Service conditions (see 4.7). The equipment shall meet the following service conditions, where a test is referenced, meeting the test shall be considered as compliance with the requirement.

3.5.1 Operation. Continuous use for a period of 500 hours, under the worldwide environmental conditions specified in 3.5.2 through 3.5.11, with a duty cycle of 23 hours on and 1 hour off. During the test specified in 4.15, there shall be no replacement of parts. Degradation of sensitivity and transmitter power output, at end of the test, shall not exceed 35 percent. The transmitter shall be capable of continuous operation for 1 hour without replacement of parts and the degradation at the end of the hour shall not exceed 10 percent.

3.5.2 Temperature (see 4.7.1).

- (a) *Operating:* Ambient temperature in the range of +150 Fahrenheit (F.) to -65° F. (The 150° F. temperature includes effect of sun load.) Exposure at the high temperature extreme need not exceed 4 hours and at the low temperature extreme need not exceed 72 hours.
- (b) *Nonoperating:* Exposure in the range of +160° F. to -80° F.; exposure at the high temperature extreme need not exceed 4 hours and at the low temperature extreme need not exceed 24 hours.

3.5.3 Relative humidity. Exposure to 97 percent relative humidity for 20 hours and 100 percent relative humidity (with condensation) for 4 hours for each 24-hour period over the period stated in 3.5.1. Meeting the tests of 4.7.2 shall be considered compliance with this requirement. (See 6.12.)

3.5.4 Elevation (see 4.7.3).

- (a) *Operating:* Up to 18,000 feet above sea level.
- (b) *Nonoperating:* Up to 25,000 feet above sea level.

3.5.5 Orientation.

- (a) *Operating (see 4.7.4):* Any orientation up to 20 degrees from normal operating position (that is: forward, backward, left or right).
- (b) *Nonoperating:* Storage in any position for a period of two years. Where the contractor is required to make a selection of parts, materials, processes, construction methods, etc., he shall be guided by this requirement. Approval of the preproduction sample (see 3.3) shall be considered as compliance with this requirement.

3.5.6 Sand and dust (see 4.7.5). As encountered during heavy traffic over dry clay roads or in desert areas.

3.5.7 Immersion (see 4.7.11). Three feet of water for two hours.

3.5.8 Suppression or radio interference. The equipment shall conform to Specification MIL-I-11748 and the Class I limits specified therein, except that a maximum of 2,500 micro-microwatts is permissible. (See 4.4.)

3.5.9 Vibration, internal. With the equipment shock-mounts (if any) blocked, the amplitude of vibration of any part, sub-assembly, or structural member of the equipment shall not exceed twice the amplitude of the vibration applied to the equipment at any frequency between 10 and 55 cycles per second (cps). (See 4.7.6.)

MIL-R-55002B(EL)

3.5.10 Vibration, equipment. The natural frequency of the equipment, mounted on its shock-mounts, shall be between 25 and 35 cps. The amplitude of vibration of the mounted equipment shall not exceed three times the amplitude of the applied vibration at any frequency between 10 and 25, or between 35 and 55, cps. (See 4.7.7.)

3.5.11 Bounce and shock. The equipment shall be capable of meeting the requirements of table II.

TABLE II. *Bounce and shock*

Paragraph heading	Paragraph No.	Performance after test
Bounce	4.7.8	Specified performance. (Note A) No physical damage.
Shock, bench-handling	4.7.9	Specified performance. (Note A) No physical damage.
Shock, ballistic	4.7.10	Operable. (Note B). Any physical damage shall be minor only.

Note A: The equipment shall meet specified performance for the following: 3.8.1 and 3.9.1.

Note B: The equipment shall meet the following requirements: 3.16.

3.6 Preconditioning (see 4.6).

3.6.1 Bounce preconditioning. The equipment shall be capable of meeting the requirements specified herein, without subsequent processing, after subjection to the bounce preconditioning of 4.6.1. (Also see 4.5.)

3.6.2 Electrical preconditioning. The equipment shall meet the sensitivity (3.8.1) and transmitter rf power (3.9.1) requirements after the 36-hour run-in test of 4.6.2.

3.7 Electrical requirements, Receiver-transmitter (see 4.8).

3.7.1 Frequency range. The receiver-transmitter shall be capable of reception and transmission in 100 kc increments from 225 to 399.9 mc.

3.7.2 Frequency stability (see 4.8.1). The frequency stability of any selected channel within the frequency range shall meet the requirements of 3.7.2.1 and 3.7.2.2.

3.7.2.1 Frequency stability vs supply voltage (see 4.8.1.1). The frequency shall drop not more than 3.5 kc when the nominal supply potential is decreased to 22 volts (v); the frequency shall not raise more than 3.0 kc when the supply potential is increased to 30 v.

3.7.2.2 Frequency stability vs temperature and time (see 4.8.1.2). The frequency error, at the applicable test temperature, shall not exceed the following:

Test temperature	Maximum frequency error
+ 150° F.	± 13 kc
+ 100° F.	± 11 kc
Ambient	± 11 kc
— 40° F.	± 18 kc
— 65° F.	± 22 kc

3.7.3 Warm-up (see 4.8.2). Within 60 seconds after the radio set has been turned on, transmitter rf power output shall be 15 w or greater, and receiver sensitivity shall be 6 microvolts (uv) or less for a signal-plus-noise output ratio of 10 decibels (db).

3.7.4 Channel changing time (see 4.8.3). The length of time required to automatically change from any preset channel to any other preset channel shall not exceed 9 seconds at room temperature and 15 seconds at —65° F.

3.7.5 Resettability (see 4.8.4). The transmitter rf power output shall change not more than 5 percent and the receiver sensitivity shall change not more than 10 percent when recycled to the same channel. Transmitter frequency error shall not exceed 2 kc.

3.7.6 Transmit-receive interval (see 4.8.5). The time interval between consecutive receive and transmit periods shall not exceed 0.5 seconds.

3.7.7 Panel meter. When tested in accordance with 4.8.6, the panel meter shall indicate as follows for the applicable switch position.

Meter switch position	Meter indication
LINE V	Mid-scale, ± 20 percent
LOW B+	Mid-scale, ± 20 percent
HIGH B+	Mid-scale, ± 20 percent
S-METER:	
No signal input	Not more than 20 percent of full scale

MIL-R-55002B(EL)

<i>Meter switch position</i>	<i>Meter indication</i>
10 uv input	At least 15 percent of full scale above no signal reading
% MOD	Mid-scale, ± 20 percent
DVR 1 _b	Mid-scale, ± 20 percent
PA 1 _b	Mid-scale, ± 20 percent
PA 1 _a	30 to 100 percent of full scale
SWR (at 16w and 309.9 mc):	
51.5-ohm termination	Less than 10 percent of full scale.
Open circuit	25 to 50 percent of full scale.
ANT jack short-circuited	Not less than 50 percent of full scale.
PWR (at 16w and 309.9 mc):	
51.5-ohm termination	50 to 70 percent to full scale
Open circuit	25 to 50 percent of full scale
ANT jack short-circuited	Not less than 50 percent of full scale.

3.7.8 Power drain (see 4.8.7). Total input power from a 26.4-v direct-current primary source shall not exceed 270 w during reception and 375 w during transportation (unmodulated).

3.7.9 Operating input potential (see 4.8.8). Nominal input voltage shall be 26.4 volts, direct-current (vdc). The equipment shall be capable of performing all its functions, but with reduced performance as permitted, with input potentials down to 22 volts. It shall also be capable of operation without component failure with input potentials up to 30 volts.

3.7.10 Protection from extreme input voltage variations (see 4.8.9). The equipment shall not be damaged when subjected to input voltage of 20 vdc for a period of at least 30 minutes or a surge voltage of 35 vdc for a one second period.

3.7.11 Reversal of polarity of input power (see 4.8.10). Reversal of polarity of the input source shall not result in damage to any component.

3.8 Electrical requirements, receiver (see 4.9).

3.8.1 Sensitivity (see 4.9.2). An input signal of not more than 6 uv shall be required to produce 250 milliwatts (mw), or greater,

output at a signal-plus-noise to noise output ratio of 10 db. Not more than 8 uv shall be allowed at -65° F. and $+150^{\circ}$ F. Not more than 8 uv shall be allowed at low input potential of 22 vdc.

3.8.2 Squelch (see 4.9.3).

- (a) The squelch sensitivity shall be adjustable so that in its maximum sensitivity position (extreme counterclockwise) it will operate with a signal of not more than 3 uv. When the control is in the minimum sensitivity position (extreme clockwise), the signal required to operate the squelch shall be not less than 45 uv. The ratio of uv to operate the squelch light at the least sensitive frequency to the most sensitive frequency shall not exceed 5 to 1.
- (b) The operation of the squelch control shall be smooth, and permit threshold adjustment on any channel frequency. The spread between maximum and minimum squelch sensitivity shall be not less than 200 degrees of shaft rotation.
- (c) With the squelch control set at the extreme clockwise position, the ratio of uv to operate the squelch shall not vary by more than 10 db, on any one channel, over the input voltage range of 22 to 30 vdc.
- (d) With the squelch control set for operation with a signal of 6 uv, the input signal difference between unsquelched and squelched conditions shall not exceed 2 to 1.
- (e) The signal-plus-noise to noise output ratio with the squelch control adjusted to open on a 6 uv input signal shall be within 4 db of that obtained with the squelch control in the OFF position, and shall be not less than 8 db.

MIL-R-55002B(EL)

3.8.3 AGC characteristics (see 4.9.2). The automatic gain control (agc) shall be such that when the signal is increased from 100 uv to 0.5 v, the audio output shall change not more than ± 5 db. When the input signal is decreased to 6 uv, the audio output relative to the 100 uv input level shall not decrease more than 3 db.

3.8.4 AGC time constant (see 4.9.5). The charge and discharge time constants of the agc circuits shall be not less than 0.03 second nor more than 0.03 second.

3.8.5 Selectivity (see 4.9.6). Overall i.f. bandwidth shall be not less than 80 kc at the 6 db points and not greater than 150 kc at the 60 db points. Peak to valley ratio within the 3 db bandpass shall not exceed 2 db. The half-bandwidths on each side of resonance shall not differ more than the following at the applicable attenuation point.

Difference in percent	Attenuation point (db)
15	6
15	20
20	40
25	60

3.8.6 IF rejection (see 4.9.7). The i.f. rejection ratio shall be not less than 100 db down from the desired frequency response.

3.8.7 Image rejection (see 4.9.8). The first i.f. and the 500-kc i.f. images shall be attenuated at least 60 db. All other i.f. image responses shall be attenuated at least 80 db.

3.8.8 Spurious response (see 4.9.9). All spurious responses ± 2 mc or more removed from the desired frequency, excluding image and i.f. responses, shall be attenuated at least 60 db. Spurious responses within ± 2 mc and ± 100 kc shall be attenuated at least 40 db.

3.8.9 Internal signals (see 4.9.10). Internal signals generated by oscillator interaction and harmonics falling on the desired frequency or within the i.f. pass band shall not cause interference on more than 10 channels within the frequency range. Such interference shall not degrade the operating sensitivity by more than 6 db, except that for frequencies of 384, 342, 294, and 276 mc, 10 db degeneration shall be permitted.

3.8.10 Cross modulation (see 4.9.11). An undesired signal of 200,000 uv, removed 1.3 percent in frequency from the desired frequency, shall result in a signal-plus-noise to noise ratio of not less than 6 db.

3.8.11 Desensitization (see 4.9.12). An undesired signal of 200,000 uv, removed 1.3 percent in frequency from a desired signal of 6 uv, shall not depress the audio reference level produced by the desired signal by more than 6 db. The desired signal, under this condition, shall produce a signal-plus-noise to noise ratio of at least 6 db.

3.8.12 Audio output (see 4.9.13). With a signal input of 100 uv, 30 percent modulated at 1,000 cps, the following audio levels shall be available when the applicable circuit is loaded individually with 600 ohms. Not more than 3 db decrease in audio level be allowed at -65° F. and at $+150^{\circ}$ F. Not more than 3 db decrease in audio level shall be allowed at the low input supply potential of 22 vdc.

Output circuit	Audio level (mv)
Loudspeaker	1,000
Remote	600
Fixed level	50
Extended range	1
Headset	250

3.8.13 Audio level adjustments (see 4.9.14). The front panel VOLUME control shall provide loudspeaker and headset output level adjustment of at least 25 db. The setting of this control shall not affect the output level of the extended range audio circuits by more than ± 2 db, or the fixed level and remote audio circuits by more than ± 3 db.

3.8.14 Audio response characteristics (see 4.9.15). The overall audio response measured at the loudspeaker output shall be within the limits specified at the applicable frequencies.

Frequency, cps	Limits
300	± 3 db
1,000	0 db (reference)
3,000	± 3 db
5,000	Not less than 5 db down
10,000	Not less than 15 db down

MIL-R-55002B(EL)

The audio response at the headset, remote, and fixed level outputs shall be within ± 2 db of the loudspeaker response.

3.8.15 Audio response characteristics, extended range (see 4.9.16). The overall audio response measured at the extended range output circuit shall be within the limits specified at the applicable frequencies.

Frequency, cps	Limits
300	± 3 db
1,000	0 db (reference)
3,000	± 3 db
5,000	± 3 db
10,000	± 3 db
15,000	Not more than 5 db down
20,000	Not more than 6 db down
25,000	Not more than 7 db down

3.8.16 Audio distortion (see 4.9.17). Total harmonic distortion shall not exceed 10 percent between 300 and 3,000 cps when measured with a constant signal input which at 1,000 cps gives the output levels specified in 3.8.12. Extended range distortion shall not exceed 12 percent.

3.8.17 Noise rejection (see 4.9.18). The modulation level at which the noise limiter starts to clip, as observed on an oscilloscope, shall be no more than 55 percent and no less than 35 percent.

3.8.18 Blocking (see 4.9.19). When an rf signal of 1 volts, modulated 30 percent at 1,000 cps, is introduced simultaneously with a desired signal of 6 microvolts (both signals on 399.9 mc), it shall be possible to receive the desired signal within 0.25 second after the 1-volt signal is turned off.

3.8.19 Maximum signal-plus-noise to noise ratio (see 4.9.20). An input signal of 10,000 uv, modulated 30 percent at 1,000 cps, shall produce a signal-plus-noise to noise ratio of not less than 35 db measured at the speaker output.

3.9 Electrical requirements, transmitter (see 4.10).

3.9.1 Transmitter rf power output (see 4.10.2). The unmodulated power output shall be not less than 16 w at any channel fre-

quency from 225.0 to 399.0 mc, inclusive. Not less than 12 w shall be allowed at -65° F. and $+150^{\circ}$ F. Not less than 4 w shall be allowed at the low input supply potential of 22 vdc.

3.9.2 Modulation capability (see 4.10.3). The rf carrier shall be modulated between 65 and 100 percent at any channel frequency from 225.0 to 399.0 mc, inclusive, with a nominal microphone input potential of 0.2 v, root-mean-square (rms).

3.9.3 Automatic modulation limiter (see 4.10.4). The modulator output voltage shall not increase more than 2 db for a 12 db increase above the nominal microphone input potential of 0.2 v, rms. When the nominal microphone input voltage is decreased by 6 db, the modulator output voltage shall decrease by at least 3 db, thereby indicating the threshold of the limiting curve. The internal adjustment shall provide at least a ± 6 db range setting of the threshold level.

3.9.4 Audio response (see 4.10.5). The overall audio response from 300 to 10,000 cps shall not exceed the following limits at the applicable frequency:

Frequency, cps	Limits
300	± 3 db
1,000	0 db (reference)
3,000	± 2 db
6,000	± 3 db
10,000	Not less than 3 db down

The microphone input voltage shall be 6 db lower than the nominal input voltage for these tests, to avoid limiting.

3.9.5 Audio response, extended range (see 4.10.6). The overall audio response shall be within ± 2 db of the 1,000 cps reference level from 3,000 to 25,000 cps and not more than 3 db down at 300 cps. The microphone input shall be 6 db lower than the nominal input voltage to avoid limiting during these tests.

3.9.6 Overall distortion (see 4.10.7). Overall transmitter distortion with an audio input of 0.2 v, rms, shall not exceed 10 percent. With the input increased by 12 db (modulation limiter operative), the distortion shall not exceed 20 percent.

MIL-R-55002B(EL)

3.9.7 Carrier noise level (see 4.10.8). Noise and hum modulation of the rf carrier shall be at least 35 db below the maximum sinusoidal modulation obtainable.

3.9.8 Sidetone (see 4.10.9). Transmitter sidetone levels measured at the headset, remote, and fixed level outputs shall be from 0 to 6 db below the output of a received signal of 100 uv modulated 30 percent at 1,000 cps. Loudspeaker sidetone shall be at least 20 db down from the received signal.

3.9.9 Microphone input impedance (see 4.10.10). Microphone input impedance shall be 150 ohms \pm 15 percent from 300 to 3,000 cps.

3.9.10 Spurious radiation (see 4.10.11). The output level of any radiated frequencies, other than the operating frequency, shall be attenuated below the carrier level by the following amounts at the frequencies specified:

Frequency, mc	Attenuation
20 to 75	Not less than 75 db
75 to 1,200:	
Carrier frequency harmonics above 500	At least 40 db down
Carrier frequency harmonics below 500	At least 30 db down
Other frequencies in this range	Not less than 65 db

3.10 Dynamotor DY-151()/U requirements (see 4.11). The dynamotor shall perform all specified functions with voltage inputs over the range of 22.0 to 30.0 vdc. With nominal input voltage, output voltages for the following load conditions shall be as specified:

Output	Load
	A (transmit condition)
No. 1	170 vdc \pm 10 percent at 140 ma
No. 2	300 vdc \pm 5 percent at 380 ma
	B (receive condition)
No. 1	170 vdc \pm 5 percent at 140 ma
No. 2	330 vdc \pm 10 percent at 85 ma

3.11 Case, Receiver-Transmitter CY-2557()/VRC-24. When tested as specified in 4.12, the continuity check shall show no shorts, opens, or undue leakage. The blower shall operate properly at 20 and 30 vdc.

3.12 Mounting MT-1436()/U. When tested as specified in 4.13, the injecting-ejecting mechanism shall operate properly. The continuity check shall show no shorts, opens, or undue leakage.

3.13 Control, Radio-Set C-1439()/U. When tested as specified in 4.14, the control shall satisfactorily perform all operational functions required. The continuity check shall show no shorts, opens, or undue leakage.

3.14 Air seal. When tested as specified in 4.16, the decrease in vacuum shall not exceed 0.01 pounds per square inch, gage (psig), per minute.

3.15 System operation. All operational and functional tests specified in 4.17 shall result in normal operation.

3.16 Operational inspection. To determine that the radio set is operable, prior to packaging and at such other times as required, the operational test specified in 4.17.1 shall be performed.

3.17 Technical literature and running spare parts. Technical literature and running spare parts shall be furnished if specified in the contract. Running spare parts shall be identical to corresponding parts in the equipment furnished on the order. (See 6.2(h) and (i).)

3.18 Workmanship. The equipment shall be manufactured and assembled in accordance with the applicable portions of the following paragraphs herein:

- 3.4.3 Plastic materials and parts.
- 3.4.4 Cleaning.
- 3.4.5 Marking.
- 3.4.6 Riveting.
- 3.4.7 Securing of parts.
- 3.4.8 Brazing.
- 3.4.9 Soldering.
- 3.4.10 Tropicalization of material.
- 3.4.11 Welding.
- 3.4.12 Wiring and cabling.
- 3.4.13 Screws, other threaded devices, and related parts.
- 3.4.15 Adjustment and repair.

MIL-R-55002B(EL)

3.4.16 Fabric and thread.

3.4.18 Controls and rotating components.

4. QUALITY ASSURANCE PROVISIONS

4.1 Responsibility for inspection. Unless otherwise specified in the contract or purchase order, the supplier is responsible for the performance of all inspection requirements as specified herein. Except as otherwise specified, the supplier may utilize his own facilities or any commercial laboratory acceptable to the Government. The Government reserves the right to perform any of the inspections set forth in the specification where such inspections are deemed necessary to assure that supplies and services conform to prescribed requirements.

4.2 Classification of inspection. Inspection shall be classified as follows:

- (a) Preproduction inspection (does not include preparation for delivery). (See 4.3.)
- (b) Inspection covered by subsidiary documents. (See 4.4.)
- (c) Quality conformance inspection.
 - (1) Quality conformance inspection of equipment before preparation for delivery. (See 4.5.)
 - (2) Quality conformance inspection of preparation for delivery. (See 4.20).

4.3 Preproduction inspection. This inspection will be performed by the Government unless otherwise specified in the contract. It shall consist of the preproduction inspection specified in table III; the inspection specified in the subsidiary documents covering the items listed in 4.4; and the inspection specified for group A, group B, and group C (see tables IV, V, and VI, respectively). The preproduction inspection will normally be performed in this order: (1) vibration, (2) bounce, (3) shock, benchhandling, (4) shock, ballistic, and (5) immersion; other preproduction inspection may precede, follow, or be interspersed between the foregoing.

TABLE III. Preproduction inspection

Inspection (For additional preproduction inspection see 4.3)	Req para	Insp para
Temperature	3.5.2	4.7.1
Relative humidity	3.5.3	4.7.2
Elevation	3.5.4	4.7.3
Orientation	3.5.5	4.7.4
Sand and dust	3.5.6	4.7.5
Vibration, internal	3.5.9	4.7.6
Vibration, equipment	3.5.10	4.7.7
Bounce	3.5.11	4.7.8
Shock, bench-handling	3.5.11	4.7.9
Shock, ballistic	3.5.11	4.7.10
Immersion	3.5.7	4.7.11
Microphone input impedance	3.9.9	4.10.10

4.4 Inspection covered by subsidiary documents. The following shall be inspected under the applicable subsidiary documents as part of the inspection of equipment before preparation for delivery:

Item	Where required
Cable assemblies	3.4.1
Finish	3.4.2
Marking	3.4.5.1
Printed wiring	3.4.19
*Suppression	3.5.8

* During preproduction inspection only.

4.5 Inspection of equipment before preparation for delivery. Each equipment produced under this specification shall be subjected to a 36-hour electrical preconditioning run-in (see 3.6.2). The contractor shall perform the inspection specified in 4.4 and 4.5.1 through 4.5.4. This does not relieve the contractor of his responsibility for performing any additional inspection which is necessary to control the quality of the product and to assure compliance with all specification requirements. The government will review and evaluate the contractor's inspection procedures and examine the contractor's inspection records. In addition, the Government—at its discretion—may perform all or any part of the specified inspection, to verify the contractor's compliance with specified requirements (see 6.10). Test equipment for Government verification inspection shall be made available by the contractor. Each unit which will be subjected to group A, group B,

MIL-R-55002B(EL)

or group C inspection shall be bounce pre-conditioned after final assembly (see 3.6.1).

4.5.1 Group A inspection. This inspection, including sampling, shall conform to table IV and the ordinary inspection procedures of Standard MIL-STD-105. Group A inspection shall be performed in any order which is

satisfactory to the Government, except that the air-seal test (4.16) shall be next to last and the operational inspection (4.17.1) shall be last.

4.5.2 Group B inspection. This inspection, including sampling, shall conform to table V and to the special procedures for small-

TABLE IV. *Group A inspection*

Inspection	Requirement Paragraph	Inspection Paragraph	AQL	
			Major	Minor
<i>Visual and mechanical</i>	3.18	4.19		
<i>RT-323()/VRC-24</i>				
Audio amplifier and modulator)	1.5 dphu*	6.5 dphu
UHF injection system)	for all	for all
RF and PA unit)	receiver	receiver
20.0-29.9 IF amplifier)	transmitter	transmitter
3.0-3.9 IF amplifier)	units	units
500 kc IF amplifier)	combined	combined
Control, C-1439()/U)	1.5 dphu	6.5 dphu
Case, CY-2557()/VRC-24)	1.0%	4.0%
Mounting MT-1436()/U)	1.0%	4.0%
Dynamotor DY-151()/U)	1.0%	4.0%
AN/VRC-24(), complete assembly)	1.0%	4.0%
<i>Electrical:</i>				
<i>RT-323()/VRC-24</i>				
Receiver:)	1.5 dphu	
Sensitivity	3.8.1	4.9.2)	for	
Squelch	3.8.2	4.9.3)	receiver	
AGC characteristics	3.8.3	4.9.4)	transmitter	**
Selectivity	3.8.5	4.9.6)	groups	
Audio output	3.8.12	4.9.13)	combined	
Audio level adjustments	3.8.13	4.9.14)		
Audio response characteristics	3.8.14	4.9.15)		
Audio response characteristics, extended range.	3.8.15	4.9.16)		
Audio distortion	3.8.16	4.9.17)		
Noise rejection	3.8.17	4.9.18)		
Signal-plus-noise-to-noise	3.8.19	4.9.20)		
Transmitter:				
Transmitter rf power output	3.9.1	4.10.2)		
Modulation capability	3.9.2	4.10.3)		
Automatic modulation limiter	3.9.3	4.10.4)		
Audio response	3.9.4	4.10.5)		
Audio response, extended range	3.9.5	4.10.6)		
Overall distortion	3.9.6	4.10.7)		
Carrier noise level	3.9.7	4.10.8)		
Sidetone	3.9.8	4.10.9)		
Dynamotor DY-151()/U	3.10	4.11	1.0%	
Case, CY-2557()/VRC-24	3.11	4.12	1.0%	
Mounting MT-1436()/U	3.12	4.13	1.0%	
Control, C-1439()/U	3.13	4.14	1.0%	
Air seal	3.14	4.16	1.0%	
System operation	3.15	4.17	1.0%	

*Defects per hundred units.

**All electrical defects are considered major.

MIL-R-55002B(EL)

TABLE V. Group B inspection

Inspection	Requirement Paragraph	Inspection Paragraph	AQL (See 4.5.2.1)
Radio Set AN/VRC-24()			
Interchangeability	3.4.17	4.18	6.5%
Frequency stability vs supply voltage	3.7.2.1	4.8.1.1)	
Frequency stability vs temperature and time	3.7.2.2	4.8.1.2)	6.5%
Warm-up	3.7.3	4.8.2)	for the
Channel changing time	3.7.4	4.8.3)	group
Resettability	3.7.5	4.8.4)	combined
Transmit-receive interval	3.7.6	4.8.5)	
Panel meter	3.7.7	4.8.6)	
Power drain	3.7.8	4.8.7)	
Operating input potential	3.7.9	4.8.8)	
Receiver-Transmitter, RT-323()/VRC-24			
Receiver:			
AGC time constant	3.8.4	4.9.5)	6.5% for
IF rejection	3.8.6	4.9.7)	the group
Image rejection	3.8.7	4.9.8)	combined
Spurious response	3.8.8	4.9.9)	
Internal signals	3.8.9	4.9.10)	
Cross modulation	3.8.10	4.9.11)	
Desensitization	3.8.11	4.9.12)	
Blocking	3.8.18	4.9.19)	
Transmitter:			
Spurious radiation	3.9.10	4.10.11)	6.5%

sample inspection of Standard MIL-STD-105. The reduced inspection procedures shall be R-1. Group B inspection shall normally be performed on inspection lots that have passed group A inspection and on samples selected from units that have been subjected to and met group A inspection. The acceptable quality level (AQL) shall be 6.5 percent defective, as specified in table V, and the inspection level shall be L-7 for normal and L-5 for reduced inspection. Group B inspection shall be performed in any order which is satisfactory to the Government.

4.5.3 Group C inspection. This inspection shall be as listed in table VI, and should normally be performed on sample units that have been subjected to and have passed group A and B inspection.

4.5.3.1 Sampling for inspection of equipment. Two equipments from the first 200, or major fraction thereof, and one from each successive 200, or major fraction thereof, shall be selected for each group C inspection,

TABLE VI. Group C inspection

Inspection	Req para	Insp para
Life	3.5.1	4.15
Protection from extreme voltage variations.	3.7.10	4.8.9
Reversal of polarity of input power.	3.7.11	4.8.10

without regard to their quality, except that the units inspected at the start of the contract shall be selected from the first units produced.

4.5.3.2 Noncompliance. If a sample unit fails group C inspection, the contractor shall immediately investigate the cause of failure and shall report to the Government inspector the results thereof and details of the corrective action taken on the process and all units of product which were manufactured with the same conditions, materials, processes, etc. If the Government inspector does not consider that the corrective action will enable the product to meet specified requirements, or if the contractor cannot determine the

MIL-R-55002B(EL)

cause of failure, the matter shall be referred to the contracting officer (see 6.5).

4.5.4 Reinspection of conforming group B and group C sample units. Unless otherwise specified, sample units which have been subjected to and passed group B or group C inspection, or both, may be accepted on contract, provided that they are resubjected to and pass group A reinspection after repair of all visible and known damage.

4.6 Preconditioning (see 3.6).

4.6.1 Bounce preconditioning (see 3.6.1). The unit, with shock mounts (if any) removed or blocked, shall be placed in its normal operation position on the table of the Package Tester, Type 1000-SC, as made by the L.A.B. Corporation, Skaneateles, N.Y., or equal. The package tester, shafts in phase, shall have a speed such that it is just possible to insert a $\frac{1}{32}$ -inch-thick strip of material under one corner or edge of the unit to a distance of 3 inches as the unit bounces. The unit shall be subjected to this preconditioning for 1 minute. After bounce preconditioning, the unit shall not be repaired, aligned, cleaned, or otherwise changed prior to subjection to acceptance inspection.

4.6.2 Electrical preconditioning (see 3.6.2). The equipment shall be operated for a period of 36 hours. The ratio of transmit to receive period shall be 1 minute transmit and 9 minutes receive. Transmitter power and receiver sensitivity shall be measured during this period. This test shall precede other electrical tests of the equipment. 100 channel selections shall be made during this period. If the equipment fails, the cause of failure shall be corrected, and the equipment resubjected to the 36-hour run-in.

4.7 Service conditions tests (see 3.5).

4.7.1 Temperature (see 3.5.2). The equipment shall be subjected to the temperature cycle shown on Standard MIL-STD 169. Tests shall be made at step 3 and step 7 as well as steps required by Standard MIL-STD-169. Power shall be applied for 20

minutes at step 7 before measurements are made. Specifications of the requirement paragraphs of the following tests shall be met:

Req para	Test para	Measurement
3.7.3	4.8.2	Warm-up
3.7.4	4.8.3	Channel changing time
3.7.5	4.8.4	Resettability
3.8.1	4.9.2	Sensitivity
3.8.2	4.9.3	Squelch
3.8.5	4.9.6	Selectivity
3.8.12	4.9.13	Audio output
3.8.14	4.9.15	Audio response characteristics
3.8.15	4.9.16	Audio response characteristics extended range
3.8.16	4.9.17	Audio distortion
3.8.19	4.9.20	Signal-plus-noise to noise ratio
3.9.1	4.10.2	Transmitter rf power output
3.9.2	4.10.3	Modulation capability
3.9.4	4.10.5	Audio response
3.9.7	4.10.8	Carrier noise level

4.7.2 Moisture-resistance test (see 3.5.3). The equipment shall be tested as follows:

4.7.2.1 Test conditions.

- Do not move equipment from the humidity chamber for measurements.
- Start measurements not more than 5 minutes after power is applied to the equipment. Complete measurements as rapidly as possible. Do not leave power on after measurements have been completed.
- Test sealed equipment with the seal broken or with the chassis removed from its enclosure.

4.7.2.2 Test method.

- Dry at $130^{\circ} \pm 5^{\circ}$ F. for 24 hours.
- Condition at $77^{\circ} \pm 5^{\circ}$ F. and 40 to 50 percent relative humidity for 24 hours.
- Take measurements specified in 4.7.2.3, and readjust or realine as necessary to meet full specification requirements.
- Subject to continuous cycling for five 48-hour cycles. Temperature,

MIL-R-55002B(EL)

relative humidity, and period of time for each portion of the cycle shall conform to Standard MIL-STD-170. The measurements specified in 4.7.2.3 shall be made during the periods shown on the standard and shall comply with 4.7.2.3.

- (e) After cycling has been completed, condition the equipment for 24 hours at $77^{\circ} \pm 5^{\circ}$ F. and 40 to 60 percent relative humidity. Then adjust for optimum performance, using only those means provided by the equipment. No repair or replacement of parts shall be made. After adjustment, the equipment shall meet full specified performance for those measurements specified in 4.7.2.3.

4.7.2.3 Performance. There shall be no mechanical deterioration, as evidenced by corrosion of metal parts or binding of rotating or sliding parts, and there shall be not more than 25 percent degradation in performance from that obtained prior to the five humidity cycles. The following measurements shall be made:

<i>Test paragraph</i>	<i>Measurement</i>
4.8.3	Channel changing time
4.8.4	Resettability
4.9.2	Sensitivity
4.9.3	Squelch
4.9.6	Selectivity
4.9.13	Audio output
4.9.15	Audio response characteristics
4.9.16	Audio response characteristics, extended range
4.9.17	Audio distortion
4.9.20	Signal-plus-noise to noise ratio
4.10.2	Transmitter rf power output
4.10.3	Modulation capability
4.10.5	Audio response
4.10.8	Carrier noise level

4.7.2.4 Failure. If any component fails to meet the performance specified in 4.7.2.3 during cycling, it shall be realigned or readjusted once. If the component fails to meet 4.7.2.3, or fails subsequently during cycling, it does not pass the test. In addition, if the equipment fails to meet full specification re-

quirements after conditioning and adjustment, as specified in 4.7.2.2(e), it does not pass the test.

4.7.3 Elevation test. The equipment, placed in its normal operating position in an altitude chamber, shall be tested as follows: (*Note:* To check temperature stabilization, place a thermocouple on the largest internal mass centrally located within the equipment.)

- (a) With the equipment placed in the chamber, operating and stabilized at room temperature, take the following measurements:

<i>Paragraph</i>	<i>Measurement</i>
4.9.2	Sensitivity
4.10.2	Transmitter rf power output
4.17.1	Operational test

- (b) Reduce the barometric pressure to 13.8 ± 0.1 inches of mercury (simulated 18,000 feet above sea level) and, after temperature and pressure stabilization for 2 hours, repeat the measurements specified in 4.7.3(a). The equipment shall meet specified performance for these measurements.
- (c) Remove the power from the equipment and further reduce the barometric pressure to 11.0 ± 0.1 inches of mercury (simulated 25,000 feet above sea level). Maintain this condition for 2 hours.
- (d) Return the chamber to 29.9 ± 0.1 inches of mercury. Apply power to the equipment and, after stabilization, repeat the measurements specified in 4.7.3(a). The equipment shall meet specified performance for these measurements.

4.7.4 Orientation test. The equipment shall be inclined for a minimum of 5 minutes in each plane (forward, backward, left, and right) to an angle of 20 ± 1 degrees. During inclination in each plane, the equipment shall

MIL-R-55002B(EL)

meet specified performance for the following measurements:

Paragraph	Measurement
4.9.2	Sensitivity
4.10.2	Transmitter rf power output

4.7.5 *Sand and dust test.* The equipment shall be tested as follows:

- (a) Place the equipment, in its normal operating position, in the test chamber. Raise and maintain the sand and dust density at 0.1 and 0.5 gram per cubic foot within the test space. The relative humidity shall not exceed 30 percent at any time during the test.
- (b) The sand and dust shall be of angular structure and shall have a particle size such that the particles can pass through screens as follows:

Screen, U.S. Standard Sieve Series	Percent
100-mesh	100
140-mesh	98 ± 2
200-mesh	90 ± 2
325-mesh	75 ± 2

- (c) Chemical analysis of the sand and dust shall be as follows:

Substance	Percent by weight
SiO ₂	97 to 99
Fe ₂ O ₃	0 to 2
Al ₂ O ₃	0 to 1
TiO ₂	0 to 2
MgO	0 to 1
Ignition losses	0 to 2

- (d) Maintain internal temperature of test chamber at 77° ± 4° F. for a period of 6 hours, with sand and dust velocity through the test chamber between 100 and 500 feet per minute.
- (e) After 6 hours at above conditions, raise the temperature to 160° ± 4° F. and maintain it at this value for 6 hours.
- (f) Remove equipment from test chamber and allow it to cool to room temperature. The equipment shall

meet specified performance for the following measurements:

Paragraph	Measurement
4.9.2	Sensitivity
4.10.2	Transmitter rf power output

- (g) Open the equipment. There shall be no evidence of deterioration of either external or internal parts.

4.7.6 *Test for internal vibration.* Internal vibration of the equipment shall be measured as follows, to determine conformance to 3.5.9:

- (a) Secure the equipment (shock mounts, if any, removed or blocked) directly to a vibration table that can be controlled within 10 percent of the specified amplitude. Mounting method shall be such that vibration within the equipment can be observed and measured. To facilitate this observation and measurement, subassemblies may be tested separately provided they are secured to the table in a manner similar to that used to mount them in the equipment.
- (b) Vibrate the equipment successively in three mutually perpendicular directions over a frequency range of 10 to 55 cps. The total excursion of the applied vibration shall be not less than 0.030 inch.
- (c) In each of the three directions, change the frequency in steps of one cps and maintain each frequency for at least 10 seconds.
- (d) Measure vibration amplitudes by optical means, or by other means, provided that vibration of the part is not affected by the measurement.

4.7.7 *Test for equipment vibration.* The receiver-transmitter, in its case, shall be tested as follows, to determine conformance to 3.5.10:

- (a) Secure the equipment on its shock mounts (Mounting MT-1436()/

MIL-R-55002B(EL)

- U) to a vibration table that can be controlled within 10 percent of the specified amplitude. The equipment shall be mounted in its normal operating position with connections (such as cable assemblies) in place.
- (b) Vibrate the complete equipment assembly, successfully, in three mutually perpendicular directions, over a frequency range of 10 to 55 cps. The total excursion of the applied vibration shall be 0.030 inch; however, this may be reduced, if necessary, to prevent excessive excursion at or near resonance provided that the excursion can still be measured.
 - (c) In each of the three directions, change the frequency in steps of one cps and maintain each frequency for at least 10 seconds.
 - (d) Measure amplitude of the applied vibration and the vibration of the equipment, for frequencies between 10 and 25 and between 35 and 55 cps.
 - (e) Determine the natural frequency of the equipment; the frequency at which the ratio of the equipment vibration to the applied vibration is greatest shall be considered the natural frequency.

4.7.8 *Bounce test (see 3.5.11)*. The equipment shall be tested on the package tester, type 1000-SC, as made by the L.A.B. Corporation, Skaneateles, N.Y., or equal. Accessories shall be selected from those listed on Drawing SC-A-46439. The test shall be as follows:

- (a) Secure the equipment to the 48- by 48-inch vehicular adapter plate, in the same manner as it would be mounted in a vehicle. The adapter plate shall be free of cracks and broken welds, and all unused holes except the 2-inch breather holes shall be plugged. All parts of the mounted surface

shall be less than 7 inches from the edge of the adapter plate.

- (b) Cover the tester bed with a panel of 1/2-inch plywood, with the top grain parallel to the drive chain. Space sixpenny nails, with the below the surface, at 6-inch intervals around all four edges and at 3-inch intervals in a 6-inch square in the center.
- (c) Place the adapter plate on the bed of the package tester. Limit the lateral motion, by wooden fences, to not more than 3 inches and not less than 1 inch. Additional barriers may be used to safeguard personnel, provided that the fore-and-aft motion of the adapter plate against the backstop is not restrained.
- (d) Operate the package tester, shafts in phase, for a total of 3 hours at 283 ± 1 revolutions per minute. Turn the adapter plate 90 degrees at the end of each 45 minutes, each time in the same direction. Rest periods may be provided to permit cooling of the resilient mounts, provided that the testing time is not less than 3 hours.

4.7.9 *Shock test; bench-handling (see 3.5.11)*. The chassis-and-front-panel assembly shall be removed from its enclosure, as for servicing, and placed in a suitable position for servicing on a solid, 2-inch fir bench top. The test shall be performed as follows, in a manner simulating shocks liable to occur during servicing:

- (a) Tilt up the assembly through an angle of 30 degrees, using one edge of the assembly as an axis, and permit the assembly to drop back freely to the horizontal. Repeat, using other practicable edges of the same horizontal face as axes, for a total of four drops.
- (b) Repeat (a), with the assembly resting on other faces, until it has been dropped for a total of four

MIL-R-55002B(EL)

times on each face on which the assembly might practically be placed during servicing.

4.7.10 Shock test; ballistic (see 3.5.11). The test shall be conducted on the "Shock Testing Machine for Light Weight Equipment" shown in Specification MIL-S-901. The equipment, including shock mounts (if any), shall be secured in its normal operating position to the steel test plate by means of the same fasteners used for vehicular installation of the equipment. The test shall consist of a total of 9 blows; one each 1-foot blow, 3-foot blow, and 5-foot blow on the back, side, and top of the test plate. As an alternative to reorienting the test plate for the blows on the side of the plate, equivalent rotation of the equipment under test is permissible.

4.7.11 Immersion test (see 3.5.7). The equipment, as prepared for field transportation, shall be immersed to a minimum depth of 3 feet of fresh water for 2 hours. Immediately prior to immersion, the temperature of the equipment shall be 40° F., or more, above the temperature of the water. The tank in which the equipment is immersed shall be of sufficient capacity to maintain the water within $\pm 2^\circ$ F. of its initial temperature, or the temperature of the water shall be maintained within those limits by other means. After completion of the 2-hour period of immersion, the equipment shall be removed from the water and wiped dry on exterior surfaces. When the equipment is opened, there shall be no evidence of leakage.

4.8 Electrical tests, receiver-transmitter (see 3.7).

4.8.1 Frequency stability (see 3.7.2).

4.8.1.1 Frequency stability vs supply voltage. With the standard input voltage of 26.4 vdc, and after a 30-minute receiver warm-up period, a portion of the rf power output of the transmitter shall be fed to a transfer oscillator, such as the Hewlett Packard Co. 540A, or equal. The frequency of the output voltage of the transfer oscillator shall then

be determined by a frequency counter and shall be the reference frequency. The input potential shall then be decreased to 22 v and after a five minute period the frequency shall again be recorded. The measurement shall be repeated for an input potential of 30 v. The test frequency shall be 399.9 mc. The transmitter shall be turned on one minute prior to measurement. Any transmitter frequency change shall be within the limits specified in 3.7.2.1.

4.8.1.2 Frequency stability vs temperature and time. With the same test setup as in 4.8.1.1, the equipment shall be temperature stabilized at room temperature with the power off. The unit shall then be turned on and the output frequency of the unmodulated transmitter carrier recorded after a one minute warm-up period. Thereafter, the output frequency shall be measured at 5 minute intervals for the first 15 minutes, and at 15 minute intervals thereafter until two hours have elapsed. The procedure and measurements shall be repeated at the following temperatures: -65° F., -40° F., room ambient, $+100^\circ$ F., and $+150^\circ$ F. The test frequency shall be 399.9 mc. The transmitter shall be turned on for one minute before making the measurement. The frequency error shall be within the limits specified in 3.7.2.2.

4.8.2 Warm-up. With the test setup as under "Transmitter rf power output" (4.10.2), the unmodulated rf power output shall be recorded after 30 seconds operation. The equipment shall then be turned off for 30 minutes and the sensitivity recorded as under Sensitivity (4.9.2) after 60 seconds operation. The test frequency shall be 399.9 mc. Power output and receiver sensitivity shall be within the limits specified in 3.7.3.

4.8.3 Channel changing time. Channels 1 and 2 shall be set to 229.9 and 299.8 mc respectively. The time required to change from channel 2 to channel 1 shall be noted at room temperature and at -65° F. The time shall be within the limits specified in 3.7.4.

MIL-R-55002B(EL)

4.8.4 Resettability. With the standard test conditions prevailing, the rf power output and receiver sensitivity shall be recorded for a total of 4 alternate channel selections approached from both higher and lower frequencies. The test frequencies shall be 389.9, and 300.0, and 235.0 mc. Receiver sensitivity, transmitter rf power output, and frequency error shall be within the limits specified in 3.7.5.

4.8.5 Transmit-receive interval. A standard rf load and a standard test voltage equivalent to 6 uv shall be fed into the antenna input through a "T" attenuator network. The headset audio output shall be applied to the vertical input of a long-persistence oscilloscope having a slow sweep. The oscilloscope shall be triggered with a pulse from the keying circuit and the time interval measured by noting the time required for the pattern changes. The requirement of 3.7.6 shall be met.

4.8.6 Panel meter. The radio set shall be operated as stated under standard receiver and transmitter test conditions (4.9.1 and 4.10.1). The transmitter shall have a nominal output of 16 w and be terminated as indicated. Meter readings shall comply with the limits specified in 3.7.7.

4.8.7 Power drain. With the radio set operating at the standard test conditions specified in 4.9.1 and 4.10.1, except that the transmitter shall be unmodulated, the requirements of 3.7.8 shall not be exceeded.

4.8.8 Operating input potential (see 3.7.9).

4.8.8.1 Operation with 22 vdc input. The equipment shall be operated with an input of 22 vdc and tested for compliance with the low operating input potential requirements of the following tests:

Test	Req. par.	Insp. par.
Sensitivity	3.8.1	4.9.2
Squelch	3.8.2	4.9.3
Audio output	3.8.12	4.9.13
Transmitter rf output	3.9.1	4.10.2

4.8.8.2 Operation with 30 vdc input. The equipment shall be operated with an input of

30 vdc and tested for compliance with the high operating input potential requirements of the following tests:

Test	Req. par.	Insp. par.
*Frequency stability vs supply voltage	3.7.2.1	4.8.1.1
Squelch	3.8.2	4.9.3
Transmitter rf output	3.9.1	4.10.2

* This test shall be performed only during the test procedure of 4.8.1.1.

4.8.9 Protection from extreme input voltage variations. The equipment shall be subjected to an input potential of 20 vdc for 30 minutes; then to a surge potential of 35 vdc for one second. The requirements of 3.7.10 shall be met.

4.8.10 Reversal of polarity of input power. Nominal input voltage, with polarity reversed, shall be applied to the equipment for 1 minute. The requirements of 3.7.11 shall be met.

4.9 Electrical tests, receiver (see 3.8).

4.9.1 Standard test conditions. All measurements shall be made in a well shielded test area, free of interference, under the conditions specified in 4.9.1.1, 4.9.1.2, and 4.9.1.3.

4.9.1.1 Test conditions.

Temperature	Normal room ambient
Humidity	Normal room ambient
Primary input power	26.4, vdc, nominal
Warm-up period	5 minutes
Audio load impedance	600 ohms, non-inductive
Test signal modulation	30 percent am at 1,000 cps
RF cable	10 feet of Radio Frequency Cable RG-8()/U
Standard audio test signal	0.2 v, rms, 1,000 cps (open circuit)

4.9.1.2 Control settings.

CHAN SEL	At desired test frequency
SQUELCH	OFF
VOLUME	As required

MIL-R-55002B(EL)**METER**

Power

Internal volume control

S-METER

On

Adjust for 1-w loudspeaker output with standard test voltage of 100 uv, and panel VOLUME control of maximum.

4.9.1.3 Standard test voltage. For the receive condition, the term "standard test voltage" is defined as an rf carrier, 30-percent amplitude modulated at 1,000 cps, fed to a 50-ohm, 6-db resistive pad in series with the signal source and the receiver.

4.9.2 Sensitivity. A standard test voltage shall be applied to the receiver input. The audio power shall be measured at the loudspeaker output, terminated in 600 ohms. The input level and VOLUME control shall be adjusted until the ratio of the audio output with the standard test voltage to the audio output power with the unmodulated standard test voltage is 10 db and the former power is 250 mw. The requirements of 3.8.1 shall be met. Test frequencies for sensitivity measurements shall be:

*399.9 mc	*300.0
388.8	299.9
377.7	288.8
366.6	277.7
355.5	266.6
344.4	255.5
333.3	244.4
322.2	233.3
311.1	*255.0

* These frequencies to be used for the 22 vdc low input potential measurements.

4.9.3 Squelch. With the standard test conditions prevailing and the standard test voltage turned off, the receiver shall be set to 399.9 mcs. The squelch sensitivity control shall be set to the maximum sensitivity position (threshold). The signal level required to deactivate the squelch as indicated by the operation of the squelch light shall be recorded. The measurement shall be repeated for the test frequencies specified under sensi-

tivity. The squelch sensitivity control shall then be adjusted for minimum sensitivity and the signal level recorded for deactivation of the squelch circuit. The measurement shall be repeated for the above test frequencies. With the receiver set to 399.9 mc and the squelch control adjusted to open on 6 uv the signal-plus-noise to noise ratio shall be recorded as measured at the loudspeaker output. The squelch control shall then be set to OFF and the signal-plus-noise to noise again recorded. All of the above tests shall be repeated for input supply potentials of 22 and 30v, at 225.0, 310.0, and 399.9 mc. The requirements of 3.8.2 shall be met.

4.9.4 AGC characteristics. The VOLUME control shall be set to produce 250 mw power output at the loudspeaker output circuit terminated in 600 ohms, with a standard test voltage input of 100 uv. Power output shall be recorded as a reference at this level. The signal input shall then be varied from 6 uv to 0.5 v and the power output noted. The ratio of the power output at the various input levels to the reference output in db shall be taken as the agc characteristic. Test frequencies shall be 399.9, 310.0, and 225.0 mc. The requirements of 3.8.3 shall be met.

4.9.5 AGC time constant. With a standard test voltage of 10,000 uv applied to the receiver, and the agc voltage applied to the vertical plates of a long persistence oscilloscope having a slow sweep and a dc amplifier, the reference level shall be noted. The signal shall then be disconnected and the discharge time measured. The charge time shall be measured by reconnecting the standard test voltage and recording the rise time on the oscilloscope. The test frequency shall be 399.9 mc. The requirements to 3.8.4 shall be met.

4.9.6 Selectivity. An unmodulated 3.5-mc signal shall be coupled to the input grid of the second receive mixer. The input level shall be adjusted to produce a reference agc voltage of -1 v. Increase the signal level 6 db and record the frequencies above and below resonance which will restore the voltage

MIL-R-55002B(EL)

to the reference level, noticing irregularities in the response curve while changing frequencies. The above shall be repeated with the signal level at 20, 40, and 60 db up. The difference in half-band-width shall be taken as the numerical difference between the deviations from resonance divided by the average of the deviations at any specified attenuation point. The requirements of 3.8.5 shall be met.

4.9.7 IF rejection. With an unmodulated standard test voltage of 10 uv at nominal frequency, record the agc voltage as a reference. Increase the signal level at the specified i-f frequencies until the referenced agc voltage is restored. The ratio between the nominal and i-f frequency signal levels shall be recorded as the rejection ratio. The test frequencies shall be:

Nominal frequencies, mc	IF frequencies, mc
399.9	3.9
	29.9
230.0	3.0
	20.0

The requirements of 3.8.6 shall be met.

4.9.8 Image rejection. The test procedure shall be identical to that for "i.f. rejection." The test frequencies shall be:

Nominal frequencies, mc	Image frequencies, mc
399.9	340.1
310.0	270.0
225.0	175.0

The requirements of 3.8.7 shall be met.

4.9.9 Spurious response. With a 10-uv standard test voltage applied to the receiver at the nominal frequency, a reference agc voltage shall be recorded and the speaker output monitored at any convenient level. The signal level shall then be increased by 60 db and the frequency varied from 10 to 420 mc, not including the frequencies from 100 kc below to 100 kc above the nominal frequency. The minimum signal input at any other frequency necessary to produce the reference agc voltage shall be recorded. The ratio of the input of the nominal operating frequency to the input at any other frequency shall be taken as the spurious rejection

ratio. Tests shall be conducted at 390.0, 355.5, and 230 mc. The requirements of 3.8.8 shall be met.

4.9.10 Internal signals. With a standard test voltage of 6 uv applied to the input of the receiver, the audio output shall be monitored by a loudspeaker connected across the loudspeaker terminals. The headset audio output circuit shall be terminated with an audio power output meter. A search shall be made on all channels for quieting and beat notes and the channel frequency recorded. Whenever interference is noted the signal level shall be increased to 12 uv and the signal-plus-noise to noise ratio recorded. The requirements of 3.8.9 shall be met.

4.9.11 Cross modulation. A standard test voltage of 6 uv at the test frequency shall be applied to the receiver input. The VOLUME control shall be set to produce a reference power output of 500 mw as measured at the loudspeaker output circuit. The modulation of the 6-uv test frequency shall then be removed. A standard test voltage of 200,000 uv from another source shall be injected 1.3 percent above the desired frequency. Signal-plus-noise to noise ratio shall then be recorded. The test shall be repeated at a frequency 1.3 percent below the desired frequency. The test frequencies shall be 395.0, 312.4, and 230.0 mc; in case a spurious frequency is encountered, the undesired signal shall be moved to the nearest useable channel. The requirements of 3.8.10 shall be met.

4.9.12 Desensitization. A standard test voltage of 6 uv at the test frequency shall be applied to the receiver input. The VOLUME control shall be set to produce a reference power output of 500 mw as measured at the loudspeaker output circuit. An unmodulated test voltage of 200,000 uv from another source shall be injected into the receiver input; this signal to be 1.3 percent above the desired frequency. The audio output and signal-plus-noise to noise ratios shall then be recorded. The test shall be repeated at a frequency 1.3 percent below the desired frequency. The test frequencies shall be 395.0,

MIL-R-55002B(EL)

312.4, and 230.0 mc. In case a spurious frequency is encountered, the undesired signal shall be moved to the nearest useable channel. The requirements of 3.8.11 shall be met.

4.9.13 Audio output. A 3.5 mc signal, equivalent to a 100 uv standard test voltage at the receiver input, shall be injected into the third receive mixer circuit. The VOLUME control shall be set to maximum. The power output shall then be measured at the loudspeaker output terminated in 600 ohms. The 600-ohm load shall then be transferred to the headset, remote, fixed level, and extended range output circuits in turn and the power output recorded for each circuit. The requirements of 3.8.12 shall be met.

4.9.14 Audio level adjustments. A standard test voltage of 100 uv shall be applied to the receiver input. The loudspeaker output shall be terminated in 600 ohms. The power output shall be measured for maximum and minimum positions of the VOLUME control. The measurement shall then be repeated with 600-ohm termination at the headset, extended range, fixed level, and remote outputs. The ratio maximum to minimum power output shall be taken as the output level adjustment. The requirements of 3.8.13 shall be met.

4.9.15 Audio response characteristics. A 3.5-mc signal, equivalent to a standard test voltage of 1,000 uv, shall be injected into the third receive mixer circuit. The VOLUME control shall be adjusted for a reference audio output of 1 w at the loudspeaker output terminated with 600 ohms. Without further adjustment of receiver controls, the power output shall be measured at modulation frequencies of 300, 3,000, 5,000, and 10,000 cps. The ratio of the power output at each modulation frequency to 1 w shall be taken as the audio response. The requirements of 3.8.14 shall be met.

4.9.16 Audio response characteristics, extended range. A 3.5-mc signal, equivalent to a standard test voltage of 1,000 uv, shall be injected into the third receive mixer circuit. The extended range output shall be termi-

nated with 600 ohms and the reference power output shall be recorded. The power output shall be measured at modulation frequencies of 300, 1,000, 5,000, 10,000, 15,000, 20,000, and 25,000 cps. The ratio of the power output at each modulation frequency to the reference output shall be taken as the audio response. The requirements of 3.8.15 shall be met.

4.9.17 Audio distortion. A 3.5-mc signal, equivalent to a standard test voltage of 1,000 uv, shall be injected into the third receive mixer circuit. The VOLUME control shall be adjusted for 1 w at the loudspeaker output terminated in 600 ohms. A Distortion Analyzer TS-723B/U, or equal, shall then be connected to the output and the measurement shall be recorded as the total harmonic distortion. Without further adjustment of receiver controls, the measurement shall be repeated individually for the headset, remote, fixed level, and extended range outputs. The requirements of 3.8.16 shall be met.

4.9.18 Noise rejection. A 3.5-mc signal, equivalent to a 100 uv standard test voltage at the receiver input, shall be injected into the third receive mixer circuit. An oscilloscope shall be connected across the loudspeaker circuit terminated in 600 ohms. The VOLUME control shall be adjusted for 1 w output. Percentage modulation shall then be adjusted to where clipping just begins to appear on the oscilloscope pattern. The modulation percentage at this point shall be recorded. The requirements of 3.8.17 shall be met.

4.9.19 Blocking. With standard test voltages of 1 v and 6 uv fed into the antenna input of the receiver through isolating pad networks, and the agc voltage applied to the vertical plates of a long persistence oscilloscope having a slow sweep and a dc amplifier, the agc reference level shall be noted visually. The 1 v signal shall then be disconnected and the time required for the agc voltage to drop to the 6 uv signal level shall be recorded. The test frequency shall be 399.9 mc. The requirements of 3.8.18 shall be met.

MIL-R-55002B(EL)

4.9.20 Maximum signal-plus-noise to noise. With a standard test voltage of 10,000 uv applied to the receiver, the VOLUME control shall be adjusted to produce 1 w at the loudspeaker output circuit terminated in 600 ohms. The modulation shall then be removed from the test signal and the power output recorded. The ratio of 1 w to the recorded output shall be taken as the maximum signal-plus-noise to noise ratio. The requirements of 3.8.19 shall be met.

4.10 Electrical tests, transmitter (see 3.9).

4.10.1 Standard test conditions. All measurements shall be made in a well shielded test area, under the conditions specified in 4.10.1.1 and 4.10.1.2.

4.10.1.1 Test conditions.

Temperature	Normal room ambient
Humidity	Normal room ambient
Primary power	26.4 vdc nominal
Warm-up period	5 minutes
Dummy microphone impedance	150-ohms, non-inductive
Standard audio test signal	0.2 v, rms, 1000 cps
Loudspeaker output impedance	600 ohms, non-inductive
Dummy antenna load	10 feet of RG-8 ()/U terminated in a 50-ohm resistive load such as Bird Electronics 611 wattmeter, or equal

4.10.1.2 Control settings.

CHAN SEL	At desired test frequency
SQUELCH	OFF
VOLUME	Maximum
Power	On
METER	PWR
Internal volume control	Same as for receiver (4.9.1.2)

Internal limiter control

Adjust for 90-percent negative modulation at 399.9 mc with standard test signal

Audio connector

600-ohm loudspeaker output

4.10.2 Transmitter rf power output. The antenna input jack shall be terminated in the dummy load through an ultra-high-frequency (uhf) low-pass filter. The transmitter shall be keyed and the power output measured on the test frequencies. The requirements of 3.9.1 shall be met. Normal test frequencies for rf power output shall be:

399.9 mc	300.0 mc
388.8 mc	299.9 mc
377.7 mc	288.8 mc
366.6 mc	277.7 mc
355.5 mc	266.6 mc
344.4 mc	255.5 mc
333.3 mc	244.4 mc
322.2 mc	233.3 mc
311.1 mc	225.0 mc

4.10.3 Modulation capability. With the standard audio test signal applied to the input, under the standard test conditions, a portion of the transmitter output shall be applied to an oscilloscope and the modulation envelope observed. The percentage of modulation shall be determined by noting the modulation envelope. The test frequencies shall be 399.0, 300.0, and 255.0 mc. The requirements of 3.9.2 shall be met.

4.10.4 Automatic modulation limiter. The standard input signal of 0.2 v shall be varied from -6 db to +20 db. The variation in modulator voltage shall be within the limits specified in 3.9.3.

4.10.5 Audio response. The transmitter shall be modulated through the dummy microphone circuit with a 0.1 v input test signal. The transmitter output shall be connected to the dummy antenna load. A portion of the output shall be coupled to a detector circuit and the reference voltage across the detector load recorded. With the amplitude

MIL-R-55002B(EL)

of the test signal held constant, the detector output voltage shall be recorded for signal frequencies of 300, 3,000, 6,000, and 10,000 cps. The ratio of these voltages to the reference voltage in db shall be taken as the response. The test frequency shall be 399.9 mc. The requirements of 3.9.4 shall be met.

4.10.6 Audio response, extended range. With the same test setup as 4.10.5, measurements shall be made at 300, 3,000, 6,000, 10,000, 15,000, and 25,000 cps. The requirements of 3.9.5 shall be met.

4.10.7 Overall distortion. With the test setup as under "Audio response," but using a standard input signal, the distortion shall be measured with a distortion analyzer at the detector output. The distortion shall also be measured at signal frequencies of 300, 500, 3,000, and 6,000 cps, using a constant input voltage. Test frequencies shall be 225.0, 310.0, and 399.9 mc. These measurements shall be repeated with the input signal increased by 12 db. The requirements of 3.9.6 shall be met.

4.10.8 Carrier noise level. With the test setup as under "Audio response," but using standard test input, the voltage across the detector load shall be measured. The modulation shall then be removed and voltage again noted. The ratio of the unmodulated voltage to the modulated voltage in db shall be recorded. The test frequency shall be 399.9 mc. The requirements of 3.9.7 shall be met.

4.10.9 Sidetone. With the test setup as under "Modulation capability," the loud-speaker output shall be loaded with 600 ohms and the a-f power output recorded. The audio load shall then be connected to the headset, remote, and fixed level outputs in turn and the a-f power outputs recorded. The audio levels, when compared to a received signal of 100 uv, 30 percent modulated at 1,000 cps, shall be within the limits specified in 3.9.8. Test frequency shall be 399.9 mc.

4.10.10 Microphone input impedance. The microphone input circuit impedance shall be measured by the resistance substitution

method. The requirements of 3.9.9 shall be met.

4.10.11 Spurious radiation. The transmitter, housed in a screen room, shall have its output connected to an rf wattmeter through a "T" attenuator such as a General Radio 874GA, or equal. A portion of the rf output shall be connected from the "T", through a coaxial connector, to a screened and grounded inclosure, containing a suitably calibrated noise meter. With the AN/VRC-24() on transmit and the levels properly adjusted, tune the noise meter through its range for each test frequency and note the level and frequency of each spurious radiation. Cross check with a uhf signal generator to determine if the responses are actually emitted from the AN/VRC-24() or are generated internally in the noise meter. The uhf generator should be known to have minimum spurious radiation (such as Hewlett Packard 608D, or equal) and shall be located in the screened inclosure with the noise meter. Test frequencies shall be 225.0, 300.5, and 399.9 mc. Spurious outputs more than 85 db down need not be recorded. The requirements of 3.9.10 shall be met.

4.11 Dynamotor DY-151()/U. Voltage and current output shall be measured in the transmit and receive condition, with loads equal to a Receiver-Transmitter, Radio RT-323()/VRC-24 attached. The requirements of 3.10 shall be met. The nominal input voltage shall be 26.4 vdc.

4.12 Case, Receiver-Transmitter, CY-2557()/VRC-24. A check for proper circuit continuity shall be made. The blower motor shall be subjected to 20 and 30 vdc for 1 minute to each voltage. The requirements of 3.11 shall be met.

4.13 Mounting MT-1436()/U. When checked as specified in 4.13.1 and 4.13.2, the requirements of 3.12 shall be met.

4.13.1 Circuit check. A check for proper circuit continuity shall be made.

4.13.2 Mechanical check. The injecting-

MIL-R-55002B(EL)

ejecting mechanism shall be checked for proper operation.

4.14 Control, Radio Set C-1439()/U. A check for proper circuit continuity shall be made. This check shall include the application of all operating voltages to the unit. The tests shall be made in such a manner that proper functioning of the controls and switches in all positions can be ascertained. The requirements of 3.13 shall be met.

4.15 Life test. The requirements of 3.5.1 shall be met.

4.15.1 Continuous transmitter operation test. The transmitter shall be operated continuously for a 1-hour period. The rf power output shall be measured at the start and end of the period.

4.15.2 Radio set operating conditions. After the continuous transmitter operation test (4.15.1), the radio set shall be operated for 500 hours under the following conditions:

Transmit-to-receive time	1 minute transmit to 9 minute receive.
Input voltage	At 30.0 v, 25 percent of the time. At 26.4, v, 65 percent of the time. At 22.0 v, 10 percent of the time.
Vibration	10 minutes of each hour at 25 ± 5 cps, at $\pm \frac{1}{32}$ -inch maximum ampli- tude.
Temperature	Between 90° and 113° F.
Channel selections	500; each 24 hours of operation, allowing 10 seconds between selections.

4.15.3 Radio set measurements. The following measurements shall be made daily. Measurements shall be taken so that all tests are recorded under all possible combinations of input voltage and vibration (see 4.15.2) during each 144 hours on test.

Attribute	Req para	Insp para
Receiver:		
Sensitivity	3.8.1	4.9.2
Squelch	3.8.2	4.9.3
AGC characteristics	3.8.3	4.9.4
Selectivity	3.8.5	4.9.6
Audio output	3.8.12	4.9.13
Audio response characteristics	3.8.14	4.9.15
Audio distortion	3.8.16	4.9.17
Noise rejection	3.8.17	4.9.18
Signal-plus-noise to noise	3.8.19	4.9.20
Transmitter:		
Transmitter rf power output	3.9.1	4.10.2
Modulation capability	3.9.2	4.10.3
Automatic modulation limiter	3.9.3	4.10.4
Audio response	3.9.4	4.10.5
Overall distortion	3.9.6	4.10.7
Carrier noise level	3.9.7	4.10.8
Sidetone	3.9.8	4.10.9

4.16 Air-seal test (see 3.14). The equipment shall be opened and closed again in such manner as to break and remake the seal. Immediately thereafter, the equipment as field transported shall be subjected to a vacuum of 1 psig (1 pound per square inch less than the atmospheric pressure surrounding the equipment) applied to the interior of the equipment inclosure. The vacuum then shall be valved-off and the interior pressure measured during the ensuing period of 1 minute. The gage used for measurement of the vacuum shall be of such accuracy that a difference of 0.01 pound can be determined readily.

4.17 System tests (see 3.15). The following system tests shall be performed:

4.17.1 Operational (see 3.16). A radio communication circuit consisting of two each Radio Sets AN/VRC-24() separated by approximately 50 feet shall be set up. Operational tests of the following shall be made from both the radio set and from Control, Radio Set C-1439()/U:

- (a) Push-to-talk operation.
- (b) Squelch tests including threshold adjustment, squelch disable, and squelch light operation.
- (c) Power on-off control.
- (d) Channel selection.
- (e) Audio level adjustment.
- (f) Case blower operation.

MIL-R-55002B(EL)

4.17.2 Remote. Push-to-talk operation through Control Group AN/GRA-6() plugged into the audio connector of either the RT-323()/VRC-24 or the C-1439()/U.

4.17.3 Retransmission. This is a squelch controlled, 2-way retransmission test with a circuit similar to Radio Set AN/GRC-5() but using Radio Set AN/VRC-24() in place of Receiver-Transmitter, Radio RT-70()/GRC. No evidence of audio regeneration or other interaction shall be noted when tested at the following frequencies:

RT-323()/VRC-24	RT-67()/GRC
225.1 mc	27.5 mc
241.7 mc	27.9 mc
265.9 mc	30.4 mc
281.4 mc	32.3 mc
305.6 mc	33.0 mc
363.2 mc	38.5 mc

4.17.4 Audio and control. With the same setup as for retransmission, the following tests shall be made from Control, Radio Set C-1439()/U:

- (a) Loudspeaker output adjustable from **SPEAKER VOLUME** control.
- (b) Headset output adjustable from **PHONE VOLUME** control.
- (c) **RAD-INT** (radio-interphone) position:
 - (1) AN/VRC-24 and AN/GRC-5() interphone audio output.
 - (2) AN/VRC-24() radio transmission with handset.
 - (3) AN/VRC-24() radio transmission with chest set in **RADIO** position.
 - (4) AN/GRC-5() interphone operation with chest set in **INTERPHONE** position.
- (d) **INT** (interphone position):
 - (1) AN/VRC-24() and AN/GRC-5() interphone audio output.
 - (2) AN/GRC-5() interphone operation with handset.
 - (3) AN/GRC-5() interphone operation with chest set in either radio or interphone position.
- (e) **RAD** (radio) position:

- (1) AN/VRC-24() audio output (remote high level).
- (2) AN/VRC-24() radio transmission with handset.
- (3) AN/VRC-24() radio transmission with chest set in **RADIO** position.

4.18 Inspection for interchangeability. The points listed in 4.18.1, 4.18.2, and 4.18.3 shall be gaged or measured to determine compliance with the physical interchangeability requirements of 3.4.17. When a listed dimension is not within specified or design limits, it shall be considered a major defect. Gage List SC-GL-57719 covers Radio Set AN/VRC-24().

4.18.1 Receiver-Transmitter, Radio RT-323()/VRC-24. The following gage points should meet the requirements of the drawings on Gage List SC-GL-57712:

- (a) The maximum length, width, and depth of the chassis.
- (b) The location of the power plug at the rear of the chassis and the two guide pins at the bottom of the front panel.
- (c) The maximum outside dimensions of the front panel.
- (d) The location of two locking bars at the bottom of the front panel (these receive locking devices on the mounting).
- (e) The location of four mounting screws on the front panel.
- (f) The location of the center-mounted locking device.
- (g) The minimum dimensions of the spring on the outside of the chassis.

4.18.2 Case, Receiver-Transmitter CY-2557()/VRC-24. The following gage points shall meet the requirements of the drawings on Gage List SC-GL-57715:

- (a) The minimum inside dimensions and the hole location at the rear of the cavity.
- (b) The location of four threaded

MIL-R-55002B(EL)

mounting holes at the opening of the cavity.

- (c) The minimum case lip dimensions that receive the outside front panel of the chassis.
- (d) The location of two guide pins and the small connector at the outside rear of the case.

4.18.3 Mounting MT-1436()/U. The following gage points shall meet the requirements of the drawings on Gage List SC-GL-57716:

- (a) The maximum and minimum length and width of mounting that receives the receiver-transmitter case.
- (b) The relative location of the large and small receptacles at the rear of the mounting.
- (c) The location of four guide pin holes (two front, two rear).
- (d) The alinement of the locking devices at the front of the mounting.

4.19 Visual and mechanical inspection. Equipment shall be examined for the defects listed in Standard MIL-STD-252.

4.20 Quality conformance inspection of preparation for delivery. Preparation for delivery shall be inspected in accordance with the Specification MIL-P-116 to determine conformance to the requirements of section 5.

4.21 Rough handling test (preparation for delivery). When a rough handling test in accordance with Specification MIL-P-116 is required by the contract (see 6.2), the following functional test shall be conducted to determine freedom from operational malfunction caused by rough handling:

Operational test (4.17.1)

5. PREPARATION FOR DELIVERY

5.1 Preservation and Packaging.

5.1.1 Level A. Each Radio Set AN/VRC-24 shall be packaged in accordance with

items 1 through 21 of figures 1, 2, and 3 and tables VII, VIII, and IX. (See 6.11.)

5.1.2 Level C. Each Radio Set AN/VRC-24 shall be packaged as specified in 5.1.1.

5.1.3 Package Performance. Package Testing shall be performed in accordance with the requirements of Specification MIL-P-116. The rough handling test or the cyclic exposure test will be performed only when invoked by the bid request or contract (see 6.2).

5.2 Packing.

5.2.1 Level A. Each Radio Set AN/VRC-24 shall be packed in accordance with Items 22 and 23 of figure 3 and table IX. The box closure shall be as specified in the appendix of the applicable box specification.

5.2.2 Level B. Each Radio Set AN/VRC-24 shall be packed in accordance with Item 22 of figure 3 and table IX, except the wood box shall be Class 1 or the cleated plywood box shall be Type IV, Class 1. The box closure shall be as specified in the appendix of the applicable box specification.

5.2.3 Level C. Each Radio Set AN/VRC-24 shall be packed as specified in 5.2.2.

5.3 Marking. Interior packages and exterior shipping containers shall be marked in accordance with Military Standard MIL-STD-129.

6. NOTES

6.1 Intended use. Radio Set AN/VRC-24() is intended to provide radio communication between ground combat troops and support aircraft. It may be used for two-way retransmission of signals with such equipments at Radio Sets AN/GRC-3(), -4(), -5(), -6(), -7(), -8(), AN/VRC-12(), -13(), -14(), and -15(). The AN/VRC-24() will net with Radio Sets AN/ARC-27(), -33(), -34(), -45(), -51(), -55(), -60(), AN/GRA-53(), -54(), AN/GRC-27(), and AN/TRC-68().

MIL-R-55002B(EL)

BILL OF MATERIAL
TABLE VII

REF No.	ITEM Nomenclature	No. Reqd.	Method MIL- P-116	Size - Inches			Spec No.	Requirement										
				L	W	D		T	C	V	G	F	S					
1	Receiver																	
2	Transmitter	1	IC-5	16 ¹⁵ / ₃₂	10%	12 ³ / ₃₂	PPP-F-320	CF	WR	SW	V3							
3	RT-323/VRC-24	1		12%	10 ¹ / ₄	1 ¹ / ₄	PPP-F-320	CF	WR	SW	V3							
4	Cell, Fiberboard	1		10	9	1	PPP-B-636	I	2									
	Cell, Fiberboard	1		18 ¹ / ₂	10%	12%												
	Box, Fiberboard	1																
	Tape,																	
	Pressure-																	
	Sensitive																	
	Box Closure	1		12	3		PPP-T-76											
		2		25	3		PPP-T-76											
		4		17	3		PPP-T-76											
5	Headset Cord	1	IC-6					II	d									
	Bag	1		5	6		MIL-B-117											
6	Headset	1	IC-6															
	F ¹ bd S.F.																	
	Cushion Wrap	1		19	10		PPP-P-291	II	2									
	Tape, Paper	1		18	3		UU-T-111		1									
	Bag	1		9	10		MIL-B-117	II	d									
	Box, Fiberboard	1		6	6	3	PPP-B-636	I	1									
	Tape, Paper	2		12	3		UU-T-111		1									
8	Microphone	1	IC-6															
	S.F. F ¹ bd																	
	Cushion Wrap	1		12	12		PPP-P-291	II	2									
	Tape, Paper	1		12	3		UU-T-111		1									
	Bag	1		8	9		MIL-B-117	II	d									
	Box, F ¹ bd	1		6	2 ¹ / ₂	2 ¹ / ₂	PPP-B-636	I	1									
	Tape, Paper	2		12	3		UU-T-111		1									
9	Loudspeaker	1	IC-5															
	S.F. F ¹ bd																	
	Cushion Wrap	1		12	22		PPP-P-291	II	2									
10																		

Lev. A-PACKED WEIGHT
Lev. A-PACKED VOLUME

T-Type
C-Class
V-Variety
G-Grade
F-Flute
S-Style

BILL OF MATERIAL
TABLE VIII

REF No.	ITEM Nomenclature	No. Req'd.	Method MIL-P-116	Size - Inches			D	Spec No.	Requirement				F	S
				L	W	H			T	C	V	C		
11	Tape, Paper	1		12	3			UU-T-111	I	1				
	Box, F'bd	1		7½	6½	3¼		PPP-B-636		2		6	B	RSC
	Tape, Pressure-Sensitive													
12	Box Closure	1		3	2			PPP-T-76						
		2		12	2			PPP-T-76						
		4		9	2			PPP-T-76						
13	Control Unit	1	IC-5											
	S.F., F'bd	1		31	12			PPP-P-291	II	2				
	Cushion Wrap	1		12	3			UU-T-111	I	1		6	B	RSC
14	Tape, Paper	1		10	7¼	4¾		PPP-B-636		2				
	Box, F'bd	1		4	2			PPP-T-76						
	Tape, P/S	2		14	2			PPP-T-76						
15	Box, Closure	4		10	2			PPP-T-76						
		1	III											
	Antenna	1		16	12			PPP-P-291	II	2				
16	S.F., F'bd	1		6	3			UU-T-111	I	1				
	Cushion Wrap	1		12½	3¾	3¾		PPP-B-636		1			B	RSC
	Tape, Paper	2		18	3			UU-T-111		1				
17	Cables,													
	CX-4630/U,	1	III											
	CG-1650/U,													
18	CX-4692/U	1		12	9¾	4		T-T-871	I	1				
	Twine	12		12	3			PPP-B-636		1			B	RSC
	Coil and Tie	1		16	3			UU-T-111		1				
19	Box, F'bd	2												
	Tape, Paper	12												
	Tubes	2	III											
20	Lamps	2	III											
	Fuses	20	III											

Lev. A-PACKED WEIGHT
Lev. A-PACKED VOLUME

T-Type
C-Class

V-Variety
G-Grade

F-Flute
S-Style

MIL-R-55002B(EL)

BILL OF MATERIAL
TABLE IX

REF No.	ITEM Nomenclature	No. Reqd.	Method MIL-F-116	Size - Inches			Spec No.	Requirement						
				L	W	D		T	C	V	G	F	S	
19	Cellulosic Material Boxes, Paper Box, F'bd	5		4	6	¼	PPP-C-843	III	a					1
		5		3	1	1	PPP-B-566	A						
		1		7	5	3¼	PPP-B-636	I	1				B	RSC
20	Consolidated Tape, Paper Box, F'bd	2		11	2		UU-T-111		1					
		1		18½	10¼	12%	PPP-B-636	I	2			3	B	RSC
21	To contain packaged Items 7, 9, 11, 13, 15, 17 and 19 Tape, P/S Box Closure	1		12	3		PPP-T-76							
		2		25	3		PPP-T-76							
		4		14	3		PPP-T-76							
		4	IC-6	14	11		MIL-B-117	II	d					4
22	Tech. Manual Bag Box, Wood contains Item 4 and 20	4		22%	18%	13%	PPP-B-621		2					
		1		72	¾	.020	PPP-B-601 or QQ-S-781	III I	2 B		2			A
23	Strapping Steel	2												

T-Type
C-Class

V-Variety
G-Grade

F-Flute
S-Style

Lev. A-PACKED WEIGHT-148 lbs.
Lev. A-PACKED VOLUME-4.56 cu. ft.

SA-SC Form 2176 Rev
1 Oct 1961

MIL-R-55002B(EL)

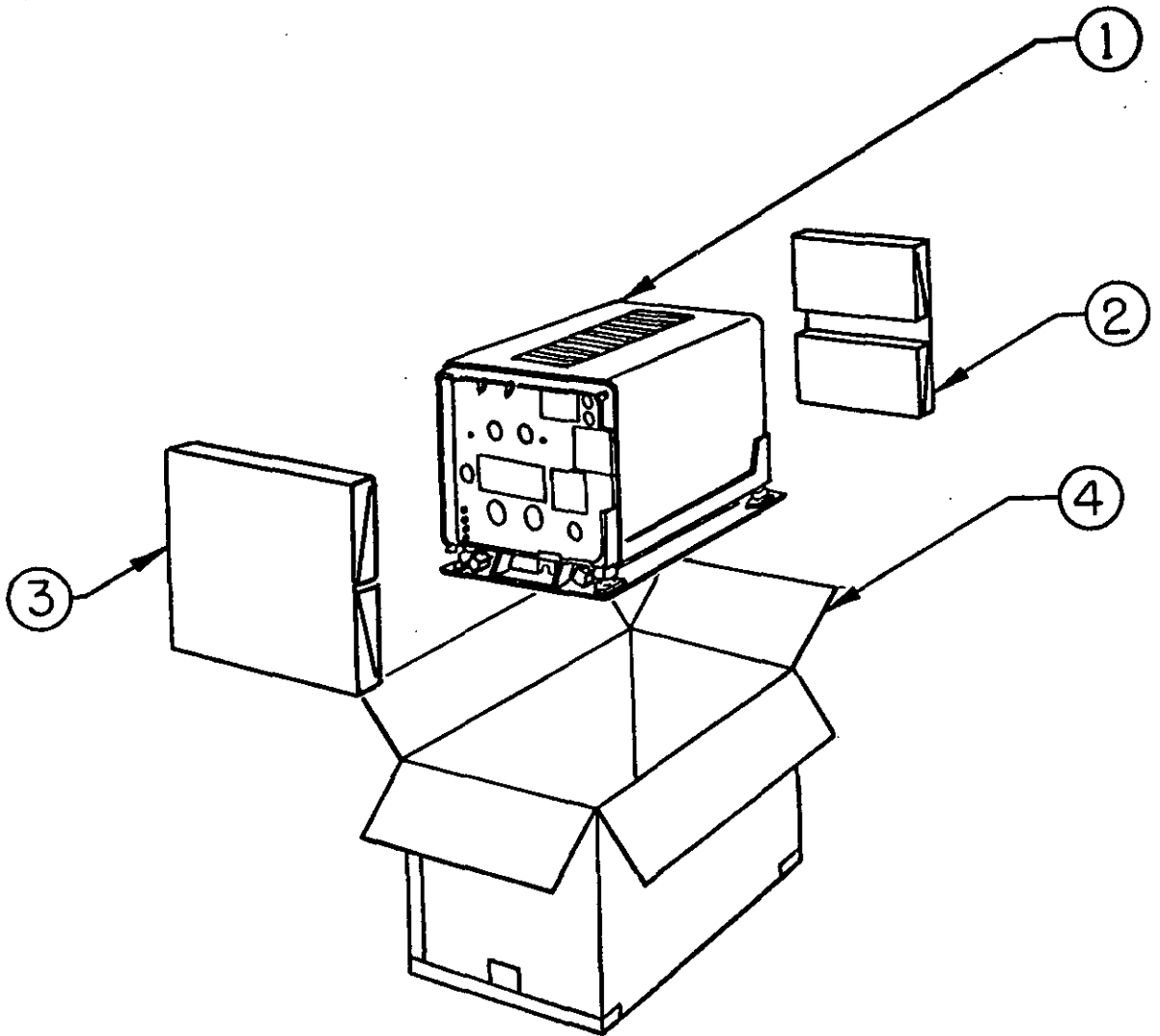

FIGURE 1. Radio set AN/VRC-24.

MIL-R-55002B(EL)

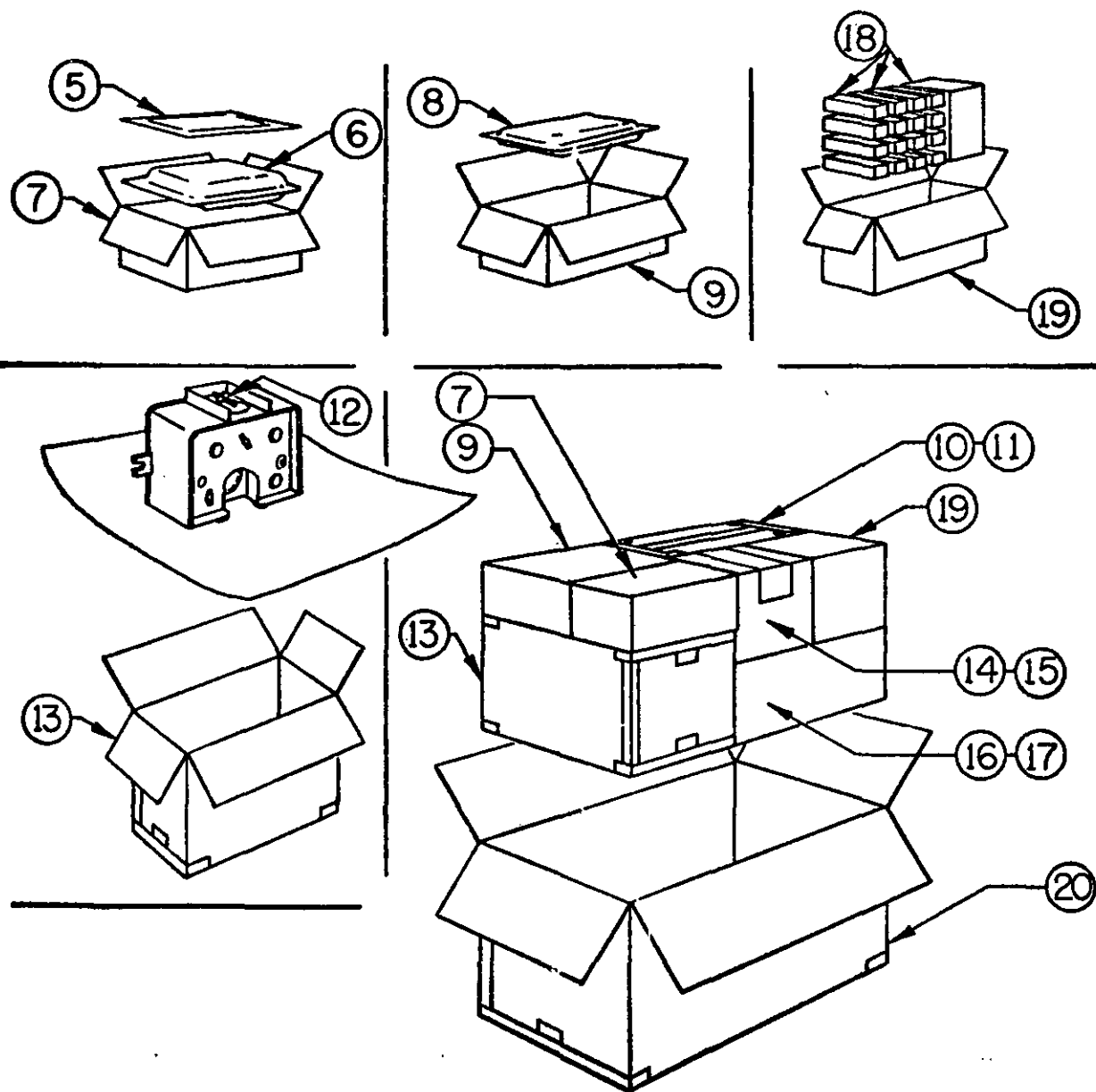

FIGURE 1A. Radio Set AN/VRC-24.

MIL-R-55002B(EL)

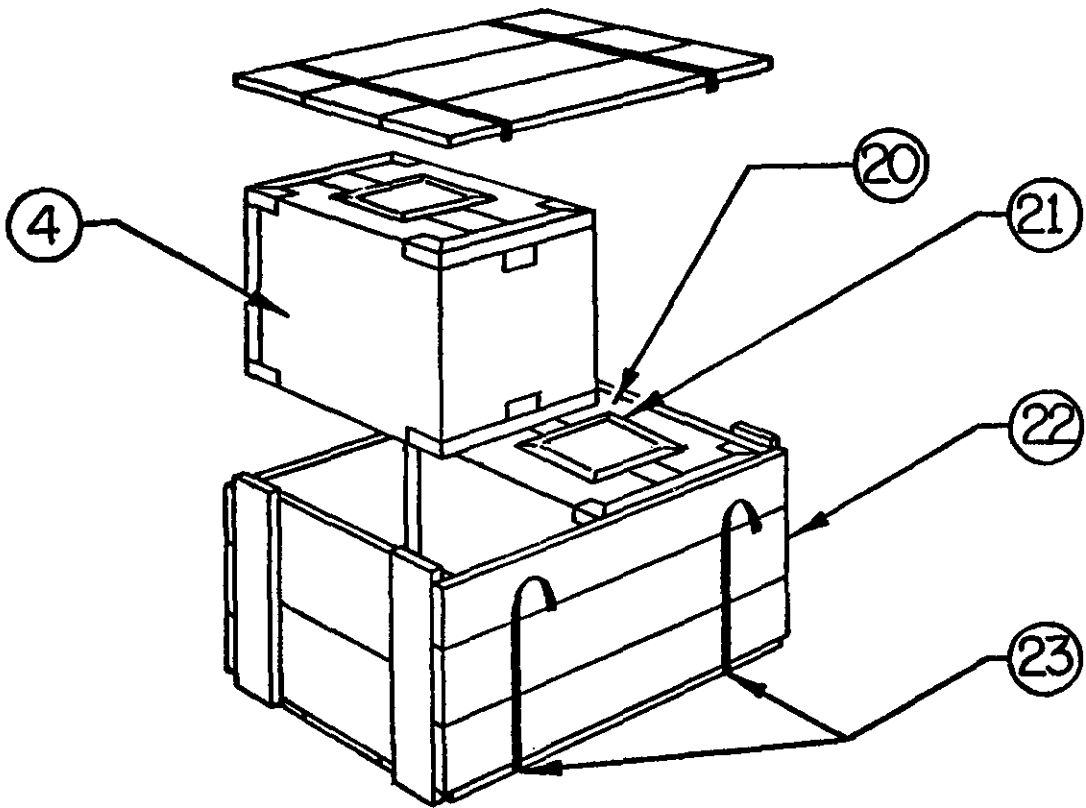

FIGURE 1B. *Radio Set AN/VRC-24.*

MIL-R-55002B(EL)

6.2 Ordering data. Procurement documents should specify the following:

- (a) Title, number, and date of this specification and any amendment thereto.
- (b) Levels of preservation, packaging, and packing required. (Level A, level B, or level C.)
- (c) Type required.
- (d) If rough handling test or cyclic exposure test is required.
- (e) Preproduction inspection:
 - (1) Two sample units of each item cited in section 1 are generally required so that lengthy environmental tests can be completed on one sample unit while complete performance measurements can be made on the second sample unit. (See 3.3.)
 - (2) Detailed requirements covering preproduction pack(s), including inspection to be performed thereon and descriptive details, plans, drawings, etc. (*Note:* These may be obtained from the Cataloging and Packaging Division, U.S. Army Electronics Materiel Agency, Philadelphia 3, Pa.)
- (f) Marking and shipping of samples.
- (g) Place of final inspection.
- (h) Technical literature required. (See 3.17.)
- (i) Quantity of running spare parts required. (See 3.17.)
- (j) Submission of the statement of treatment referenced in 3.4.10.4, as soon as possible after award of contract. This statement should be submitted to the contracting officer.

6.3 Color (see 3.4.2). The color chip furnished by the procuring agency will be color chip No. X-24087, and may be obtained upon request to Commanding General, U.S. Army Electronics Materiel Agency, 225 South Eighteenth Street, Philadelphia 3, Pa., ATTN: SELMA-J4b.

6.4 Definitions. Interchangeable, substitute, and replacement items are defined in Standard MIL-STD-447.

6.4.1 Equipment divisions. The terms used herein for equipment divisions conform to Standard MIL-STD-280.

6.4.2 Definitions of inspection terms. The inspection terms used herein conform to Standard MIL-STD-109. The following are abbreviated definitions selected from those given therein for immediate reference:

6.4.2.1 Inspection. Inspection is the examination or testing, or both, of supplies to determine compliance with applicable requirements. Sampling is an element of inspection.

6.4.2.2 Examination. Examination consists of simple, generally nondestructive determinations of compliance, without use of special testing equipment.

6.4.2.3 Testing. Testing consists of determinations of compliance, using technical means.

6.5 Group C inspection. Approval to ship may be withheld, at the discretion of the Government, pending the decision from the contracting officer on the adequacy of corrective action. (See 4.5.3.2.)

6.6 Location of air seal and operational inspection. It is desirable that the air seal test (4.16) and the operational inspection (4.17.1.1) be performed at a location that will minimize handling (which might cause damage to the equipment) after this inspection is completed. Any preparation for shipment which would require breaking of the equipment seal should be accomplished prior to the air-seal test so that the seal may remain intact thereafter. It is recommended that the entire lot (including all previously inspected sample units) be sampled and inspected immediately prior to packaging.

6.7 Nomenclature. The parentheses in the nomenclature will be deleted or replaced by a

MIL-R-55002B(EL)

letter identifying the particular design; for example: AN/VRC-24W. The contractor should apply for nomenclature in accordance with the applicable clause in the contract. (See 1.1.)

6.8 Color of textiles (see 3.4.16). Standard samples of Olive Drab No. 7 may be obtained from the Sample Loan Unit, Military Clothing and Textile Supply Agency, Philadelphia, Pennsylvania. When requesting samples, indication should be given as to type of material concerned.

6.10 Verification inspection. Verification by the Government will be limited to the amount deemed necessary to determine compliance with the contract and will be limited in severity to the definitive quality assurance provisions established in this specification and the contract. The amount of verification inspection by the Government will be adjusted to make maximum utilization of the contractor's quality control system and the quality history of the product.

6.11 Dimensional data. Sizes of packaging materials prescribed in section 5 are based on the dimensions of the equipment cited on the applicable Bill of Material. When the dimensions of the equipment vary from those cited, the sizes of the packaging materials shall be adjusted accordingly. When shown

in the Bill of Materials (see sec. 5), corrugated fiberboard manufactured with A, B, or C fluting may be used at the option of the contractor. When the fluting used is not the same as that cited in the Bill of Material, the dimensions of the affected packaging and packing materials will be adjusted accordingly.

6.12 Humidity. Natural climatic extremes may include 100 percent relative humidity, with condensation, up to 4 hours at a time. This requirement (see 3.5.3) is specified by Military Standard MIL-STD-210. The moisture resistance test (see 4.7.2) using Military Standard MIL-STD-170, is a procedure that gives a practical test approximating the natural conditions.

Notice: When Government drawings, specifications, or other data are used for any purpose other than in connection with a definitely related Government procurement operation, the United States Government thereby incurs no responsibility nor any obligation whatsoever; and the fact that the Government may have formulated, furnished, or in any way supplied the said drawings, specifications, or other data is not to be regarded by implication or otherwise as in any manner licensing the holder or any other person or corporation, or conveying any rights or permission to manufacture, use, or sell any patented invention that may in any way be related thereto.

Custodian:
Army--EL

Preparing activity:
Army--EL
Project No. 5820-A201

FOLD

POSTAGE AND FEES PAID



OFFICIAL BUSINESS
PENALTY FOR PRIVATE USE \$300

Commander
US Army Electronics Command
ATTN: DRSEL-RD-TS-S
Fort Monmouth, NJ 07703

FOLD

STANDARDIZATION DOCUMENT IMPROVEMENT PROPOSAL

OMB Approval
No. 22-R255

INSTRUCTIONS: The purpose of this form is to solicit beneficial comments which will help achieve procurement of suitable products at reasonable cost and minimum delay, or will otherwise enhance use of the document. DoD contractors, government activities, or manufacturers/vendors who are prospective suppliers of the product are invited to submit comments to the government. Fold on lines on reverse side, staple in corner, and send to preparing activity. Comments submitted on this form do not constitute or imply authorization to waive any portion of the referenced document(s) or to amend contractual requirements. Attach any pertinent data which may be of use in improving this document. If there are additional papers, attach to form and place both in an envelope addressed to preparing activity.

DOCUMENT IDENTIFIER AND TITLE

NAME OF ORGANIZATION AND ADDRESS

CONTRACT NUMBER

MATERIAL PROCURED UNDER A

 DIRECT GOVERNMENT CONTRACT SUBCONTRACT

1. HAS ANY PART OF THE DOCUMENT CREATED PROBLEMS OR REQUIRED INTERPRETATION IN PROCUREMENT USE?

A. GIVE PARAGRAPH NUMBER AND WORDING.

B. RECOMMENDATIONS FOR CORRECTING THE DEFICIENCIES

2. COMMENTS ON ANY DOCUMENT REQUIREMENT CONSIDERED TOO RIGID

3. IS THE DOCUMENT RESTRICTIVE?

 YES NO (If "Yes", in what way?)

4. REMARKS

SUBMITTED BY (Printed or typed name and address - Optional)

TELEPHONE NO.

DATE

DD FORM 1426
1 JAN 72

REPLACES EDITION OF 1 JAN 66 WHICH MAY BE USED

S/N 0102-014-1802