

INCH-POUND

MIL-P-5515D

14 Mar 91
SUPERSEDING

MIL-P-5515C

17 MAY 1972

MILITARY SPECIFICATION

PUMP, HYDRAULIC, RAM, HAND DRIVEN

This specification is approved for use by all Department and Agencies of the Department of Defense.

1. SCOPE AND CLASSIFICATION

1.1 Scope. This specification covers hand driven, hydraulic ram pumps used on type I (-65° to +160° F) aircraft hydraulic systems.

1.2 Classification. Pumps shall be of the following classes, as specified:

Class 1500	1,500 PSI operating pressure
Class 3000	3,000 PSI operating pressure

2. APPLICABLE DOCUMENTS

2.1 Government documents.

2.1.1 Specifications, standards, and handbooks. The following specifications, standards, and handbooks form a part of this document to the extent specified herein. Unless otherwise specified, the issues of these documents are those listed in the issue of the Department of Defense Index of Specifications and Standards (DODISS) and supplement thereto, cited in the solicitation (see 6.2).

SPECIFICATIONS

Military

MIL-P-116
MIL-H-8775

Preservation, Methods Of
Hydraulic System Components, Aircraft And
Missiles, General Specification For

Beneficial comments (recommendations, additions, deletions) and any pertinent data which may be of use in improving this document should be addressed to: Oklahoma City Air Logistics Center/TIMLA, Tinker AFB, OK 73145-5990 by using Standardization Document Improvement Proposal (DD Form 1426) appearing at the end this document or by letter.

AMSC N/A

FSC4320

DISTRIBUTION STATEMENT A. Approved for public release; distribution is unlimited.

MIL-P-5515D

STANDARDS

Military

MIL-STD-129	Marking For Shipment And Storage
MIL-STD-970	Standards & Specifications, Order Of Preference For The Selection Of
MIL-STD-2073/1A	DOD Material Procedures For Development And Application Of Packing Requirement
MS21344	Fitting - Installation Of Flared Tube, Straight Threaded Connectors, Design Standard For
AN6201	Pump, Hydraulic Hand
AN6248	Pump, Hydraulic Hand, Type 3000

(Unless otherwise indicated, copies of federal and military specifications, standards, and handbooks are available from the Standardization Document Order Desk, 700 Robbins Ave, Building #4, Section D, Philadelphia, PA. 19111-5094.)

2.2 Non-Government publications. The following document(s) form a part of this document to the extent specified herein. Unless otherwise specified, issue of the DODISS cited in the solicitation. Unless otherwise specified, the issues of documents not listed in the DODISS are the issues of the documents cited in the solicitation (see 6.2).

American Society For Testing and Materials (ASTM)

ASTM D3951 Packaging, Commercial

(Application for copies should be addressed to : ASTM, 1916 Race St, Philadelphia, PA 19103.)

(Non-Government standards and other publications are normally available from the organizations that prepare or distribute the documents. These documents also may be available in or through libraries or other informational services.)

2.3 Order of precedence. In the event of a conflict between the text of this document and the references cited herein (except for related associated detail specifications, specification sheets, or MS standards), the text of this document takes precedence. Nothing in this document, however, supersedes applicable laws and regulations unless a specific exemption has been obtained.

3. REQUIREMENTS

3.1 General. The requirements of Type I Hydraulic System and hand Pump Standards listed herein apply as requirements of this specification.

3.1.1 Class. Pumps shall be of two classes.

MIL-P-5515D

3.1.1.1 Class 1500. A 1500 psi operating pressure and the requirements of AN6201 apply for this class pump.

3.1.1.2 Class 3000. A 3000 psi operating pressure and the requirements of AN 6248 apply for this class pump.

3.2 Qualifications. Pumps furnished under this specification shall be products which are qualified for listing on the applicable qualified products list at the time set for opening of bids (see 4.4 and 6.3).

3.3 General specification. The requirements of MIL-H-8775 apply as requirements of this specification with the exceptions and additions called out herein. When the two specifications conflict, this specification shall govern.

3.3.1 Exceptions. The exceptions to the requirement of MIL-H-8775 are:

- a. Only Type I system requirements apply to this specification.
- b. The temperature conditions for qualification testing do not apply to this specification.

3.3.2 Additions. The design and construction requirements specified herein are in addition to those requirements specified in MIL-H-8775.

3.4 Selection of specifications and standards. Specifications and standards for necessary commodities and services not specified herein shall be selected in accordance with MIL-STD-970.

3.5 Materials. Material shall conform to applicable section of MIL-H-8775.

3.6 Design and construction.

3.6.1 Clearance volume. The pump clearance volume, that is the cylinder volume not swept by the piston travel, shall be kept to a minimum and shall not exceed 20 percent of the total swept volume.

3.6.2 Displacement. The pumps shall be double-action and shall have an output differential not exceeding .50 cubic inch per stroke. The Class 1500 pumps shall have a displacement of 1.25 to 1.50 cubic inches per cycle. The class 3000 pumps shall have a minimum displacement of 0.7 cubic inches per cycle.

3.7 PERFORMANCE

3.7.1 Structural strength. The structural strength of the pump parts, when installed in a normal manner, shall provide ample strength and rigidity to withstand, without failure, a normal handle torque; side torque; and wrench torques when tested in accordance with structural strength tests (see 4.4.6.1).

3.7.2 Priming. When tested in accordance with priming test (see 4.4.6.2), pumps shall prime completely from a dry suction line in not more than 10 cycles of operation for Class 1500 pumps and in not more than 15 cycles for Class 3000 pumps.

MIL-P-5515D

3.7.3 Ability to hold prime. When testing pumps in accordance with ability to hold prime test (see 4.4.6.3), there shall be no visible external leakage from the pump or suction tube.

3.7.4 Pressure.

3.7.4.1 Output pressure. When tested in accordance with output pressure test (see 4.4.6.4.1), pumps shall be capable of delivering 85 percent of their displacement per cycle at the required operating pressures.

3.7.4.2 Proof pressures. Class 1500 and Class 3000 shall be capable of withstanding 2250 and 4500 psi proof pressure, respectively.

3.7.4.3 Burst pressure. Class 1500 and Class 3000 shall be capable of withstanding 3750 psi and 7500 psi, respectively.

3.7.5 Handle Torque. Normal handle torque shall not exceed 1350 pound inches when tested in accordance with handle torque test (see 4.4.6.4.1.1) for the complete cycle. For pumps designed after 1 January 1977, the normal handle torque shall not exceed 1080 pound inches when tested in accordance with handle torque test (see 4.4.6.4.1.1) for the complete cycle.

3.7.6 Cold operation.

3.7.6.1 Cold priming. Pumps shall prime completely at -65°F (see 4.4.6.5.1) from a dry suction line in not more than 12 cycles of operation for the Class 1500 pumps and not more than 17 cycles for the Class 3000 pumps.

3.7.6.2 Cold cycling. At -65° (see 4.4.6.5.2) pumps shall deliver 85 percent of their displacement per cycle at the specified operating pressure. During rapid warm up there shall be no evidence of binding or other malfunction.

3.7.7 Efficiency.

3.7.7.1 Volumetric. Output volume, when tested in accordance with volumetric efficiency test (see 4.4.6.6) shall not be less than 85 percent of their design displacement unless otherwise specified herein.

3.7.7.2 Mechanical. The output load (output pressure in psi multiplied by area of pump piston in square inches) shall not be less than 80 percent of axial input load (see 4.4.6.4.1.2) for full stroke at operating pressure.

3.7.8 Endurance. The pumps shall withstand 70,000 cycles at specified conditions (

a. Without malfunctioning or failure.

b. No external leakage except at running packings. This leakage, at no time during the test shall exceed two drops for 25 cycles nor shall the total leakage for the test exceed one drop per 25 cycles.

c. No bearings or other parts shall be replaced except running packings provided the original packings operate at least 40,000 cycles without excessive leakage.

MIL-P-5515D

d. At any time during specified test output volume shall not be less than 75 percent of the pump displacement. This output volume shall be reputable when tested in accordance with volumetric efficiency test (4.4.6.6).

4. QUALITY ASSURANCE PROVISIONS

4.1 Responsibility for inspection. Unless otherwise specified in the contract or purchase order, the contractor is responsible for the performance of all inspection requirements (examinations and tests) as specified herein. Except as otherwise specified in the contract or purchase order, the contractor may use his own or any other facilities suitable for the performance of the inspection requirements specified herein, unless disapproved by the Government. The Government reserves the right to perform any of the inspections set forth in this specification where such inspections are deemed necessary to ensure supplies and services conform to prescribed requirements.

4.1.1 Responsibility for compliance. All items shall meet all requirements of sections 3 and 5. The inspection set forth in this specification shall become a part of the contractor's overall inspection system or quality program. The absence of any inspection requirements in the specification shall not relieve the contractor of the responsibility of ensuring that all products or supplies submitted to the Government for acceptance comply with all requirements of the contract. Sampling inspection, as part of manufacturing operations, is an acceptable practice to ascertain conformance to requirements, however, this does not authorize submission of known defective material, either indicated or actual, nor does it commit the Government to accept defective material.

4.2 Classification of inspections. The inspection requirements specified herein are classified as follows:

- a. Qualification inspection (see 4.3).
- b. Quality conformance inspection (see 4.4).

4.3 Inspection conditions. Unless otherwise specified, all inspections shall be performed in accordance with the test conditions specified in MIL-H-8775 shall apply except the temperature conditions. Unless otherwise specified in each individual test method herein, fluid and ambient temperatures shall be between 70 and 120° F.

4.4 Qualification inspections.

4.4.1 Qualification test samples. Test samples as specified in MIL-H-8775 shall apply for each class of pump.

4.4.2 Qualification inspection. Qualification inspection and testing shall be as specified in Table I.

MIL-P-5515D

TABLE I

Examination or Test	Test Method Paragraph	Samples to Be Inspected
Material	4.4.5	Min & Max
Workmanship	4.4.5	Min & Max
Physical Dimensions	4.4.5	Min & Max
Design and Construction	4.4.5	Min & Max
Clearance Volume	4.4.5	Min & Max
Displacement	4.4.5	Min & Max
Markings and Identification	4.4.5	Min & Max
Structural Strength	4.4.6.1	Max
Priming	4.4.6.2	Min & Max
Ability to Hold Prime	4.4.6.3	Max
Output Pressure	4.4.6.4.1	Max
Handle Torque	4.4.6.4.1.1	Max
Mechanical Efficiency	4.4.6.4.1.2	Max
Proof Pressure	4.4.6.4.2	Max
Burst Pressure	4.4.6.4.3	Max
Cold Priming	4.4.6.5.1	Min
Cold Cycling	4.4.6.5.2	Min
Volumetric Efficiency	4.4.6.6	Max
Endurance	4.4.6.7	Max

4.4.3 Quality conformance inspection. The visual inspection (4.4.5) and pressure proof test (4.4.6.4.2) of Table I shall apply for quality conformance inspection to determine conformance with this specification.

4.4.4 Sampling. Each pump shall be subjected to and meet the requirements of quality conformance inspections.

4.4.5 Inspection methods. A dimensional analysis and inspections of pump components shall be made to determine conformance with requirements of material, design and construction, and qualifications samples as specified in MIL-H-8775 and this specification.

4.4.6 Test methods.

4.4.6.1 Structural strength. Mount the pump securely by the mounting lugs to the test stand. With the fluid ports open and the handle in the forward position, apply a 300 lb force to the handle 30 inches from the pivot. Repeat this test with the handle in the aft position. Return the handle to within 5 degrees of mid travel position and apply 160 pounds force to 30 inches from the pivot perpendicular to the direction of travel. Repeat this test applying the load to the opposite side of the handle. Install fluid fittings and torque 250 percent of the maximum torque value specified for fittings in MS21344.

4.4.6.2 Priming. The pump shall be mounted in the normal operating position with tube (size as specified in the applicable standard) connecting the suction port to hydraulic fluid supply. The fluid level shall not be less than 30 inches below pump suction port as illustrated by Figure 1. Operate pump at a rate not less than 20 strokes per minute to determine the pumping cycles necessary to produce flow.

MIL-P-5515D

4.4.6.3 Ability to hold prime. Mount pump and suction tube as specified in priming test (see 4.4.6.2) and completely prime pump, overflowing through the pump discharge port to the atmosphere. After pumping is stopped and allowing not less than 30 minutes, determine leakage from pump or suction line. Ambient and fluid temperature shall not vary more than two degrees during this test.

4.4.6.4 Pressure.

4.4.6.4.1 Output pressure. Connect pump to fluid supply and a pressure regulator that is regulated to the required output pressure as illustrated by Figure 2. Operate pump to provide flow at this regulated pressure.

4.4.6.4.1.1 Handle torque. After operating pump to produce the required output pressure (see 4.4.6.4.1); increase flow by slowly applying loads at not greater than 30 inches from pivot point of a suitable pump handle to determine the necessary torque for entire stroke in both directions.

4.4.6.4.1.2 Mechanical efficiency. Using loads, determined in handle torque tests, and the mechanical advantage provided by the geometry of the linkages, determine the maximum axial input loads on pump piston for both stroke directions. Calculate mechanical efficiency for both stroke directions.

4.4.6.4.2 Proof pressure. Apply a load, sufficient to produce the required proof pressure, at the end of a suitable handle for 5 minutes for each stroke direction.

4.4.6.4.3 Burst pressure. Apply required burst pressure with an external hydraulic power supply to all internal cavities of the pump that are subjected to operating pressure.

4.4.6.5 Cold operation.

4.4.6.5.1 Cold priming. Cold soak an empty pump and test equipment as illustrated by Figure 1 at not less than -65°F for not less than 72 hours. Test pump in accordance with priming test (see 4.4.6.2) except at cold soak temperature.

4.4.6.5.2 Cold cycling. Connect the above cold soaked pump to a pressure regulator that is regulated to the required output pressure. Suction tube may be changed to provide not less than 5 inches for the suction head. Operate pump at not less than 20 cycles per minute through at least 25 complete cycles with pump and fluid held at -55 to -65°F to:

- a. Produce flow at output pressure.
- b. Determine output volume per cycle.

Cycle pump at sufficient interval to determine binding or other malfunction due to differential expansion of mating parts, during rapid warmup to 120 - 129°F .

4.4.6.6 Volumetric efficiency. Mount pump and associated test equipment as illustrated by Figure 2. Operate pump at not less than 55 cycles per minute. Determine output volume per cycle for calculating volumetric efficiency.

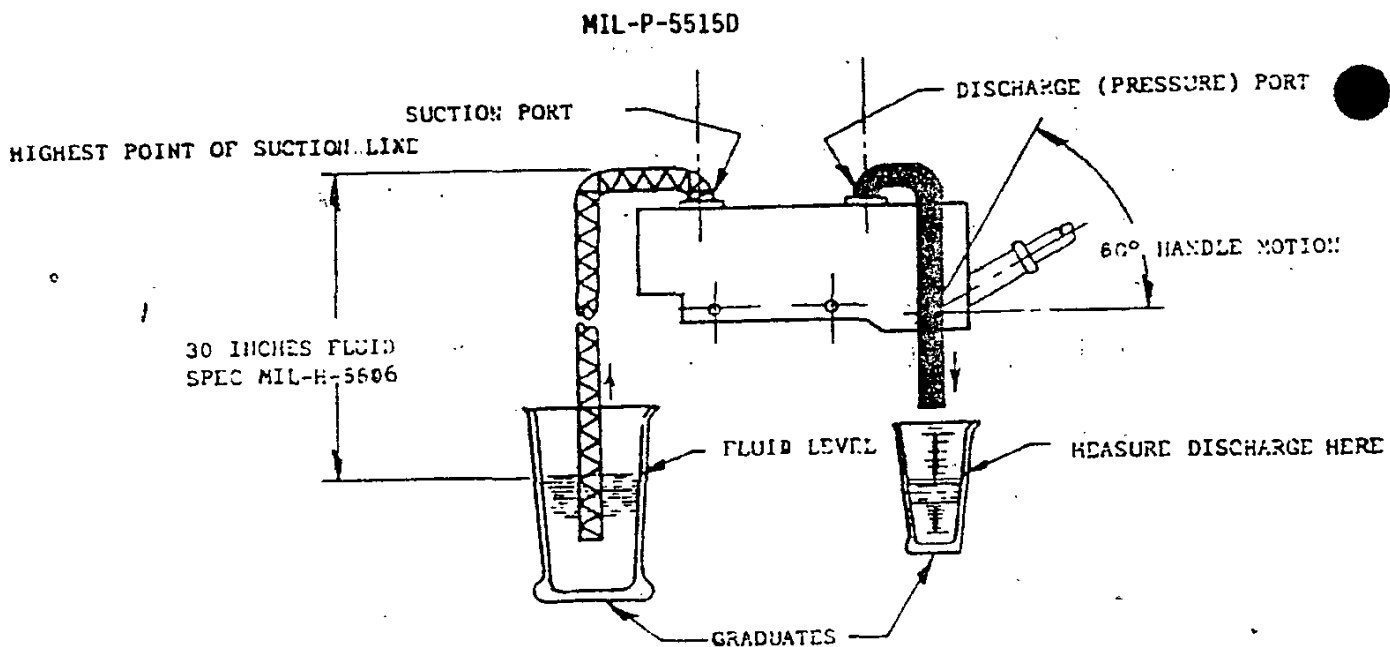

Figure 1. Hand pump priming and flow test set-up.

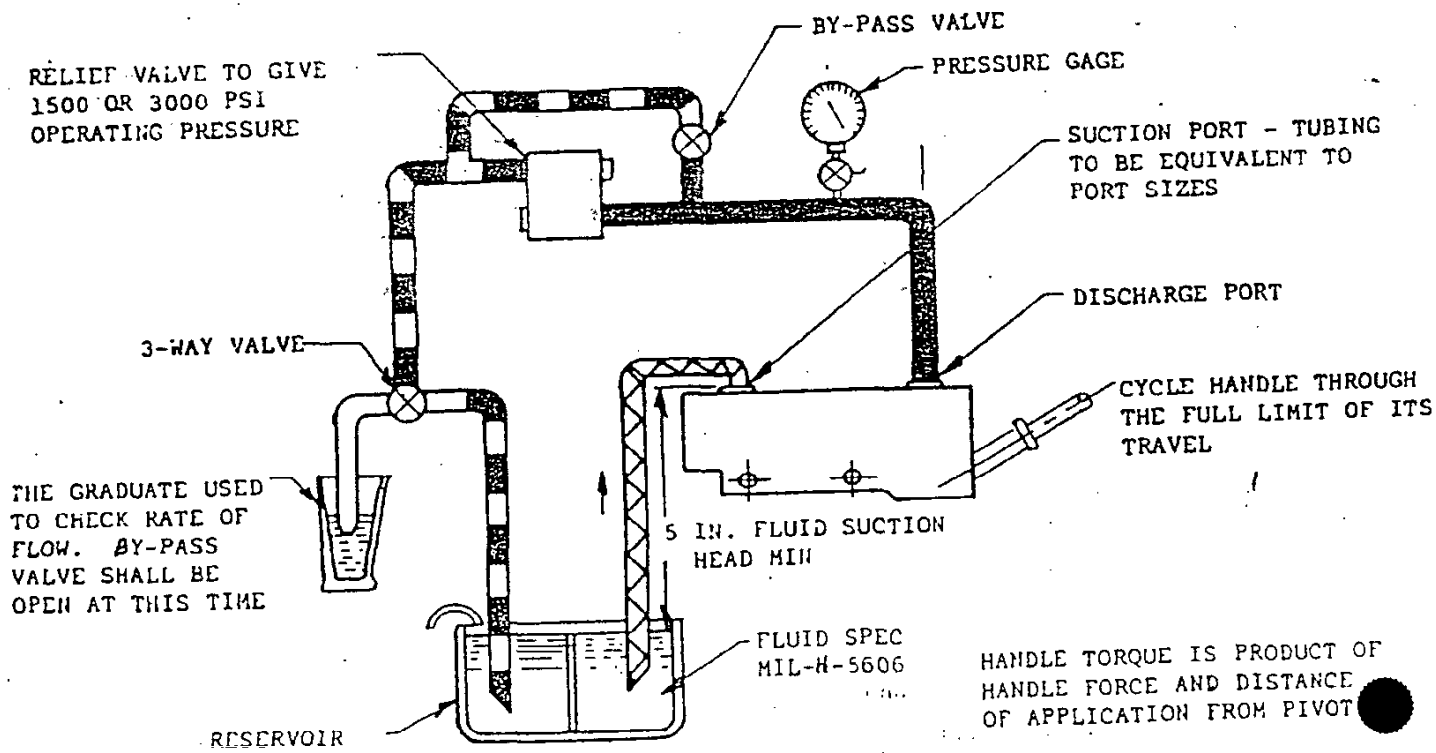

Figure 2. Hand pump cycling test set-up.

MIL-P-5515D

4.4.6.7 Endurance. Mount pump and associated test equipment as illustrated by Figure 2. The suction head shall not be less than 5 inches. Means shall be provided to open flow (0 psi output pressure) and regulate output within ± 50 psi of required operating pressure. Operate pump at 30 to 40 cycles per minute at not less than 95 percent of full stroke as follows:

- a. Operate pump for 10,000 cycles at required output pressure and determine leakage.
- b. Operate pump at open flow (0 psi output pressure) sufficiently to determine volume per cycle for calculating volumetric efficiency.
- c. Repeat a. and b. (above) until 70,000 cycles have accumulated.

4.7 Inspection of the preservation, packaging, packing and marking for shipment and storage. Sample items or packs and the inspection of the preservation, packaging, packing and marking for shipment and storage shall be in accordance with the requirements of Section 5, or the documents specified therein.

5. PACKAGING

5.1 Preservation. Unless otherwise specified by the procuring activity, the valve shall be Level A, C, or Industrial IAW MIL-STD-2073/IA.

5.1.1 Level A.

5.1.1.1 Cleaning. Cleaning shall be accomplished in accordance with the procedures of MIL-P-116.

5.1.1.2 Unit Packaging. Each pump shall be packaged in quantity unit packs of one each in accordance with method IA of MIL-P-116.

5.1.2 Level C. Each pump shall be provided preservation which will afford adequate protection against corrosion, deterioration, and physical damage during shipment from supply source to the first receiving activity. This level may conform to the supplier's industrial practice.

5.2 Packing. Packing shall be Level A, B, C, or Industrial as specified (see 6.2).

5.2.1 Level A. Pumps preserved as specified in 5.1.1 shall be packed in exterior type weather resistant shipping containers.

5.2.2 Level B. Pumps preserved as specified in 5.1.1 shall be packed in domestic type shipping containers.

5.2.2.1 Closure. All containers shall be closed, sealed, and reinforced in accordance with the applicable container specification.

5.2.3 Level C. Packing shall be applied which affords adequate protection during domestic shipment from the supply source to the first receiving activity for immediate use. This level shall conform to applicable carrier rules and regulations.

MIL-P-5515D

5.2.4 Industrial. The packaged pump shall be packed in accordance with ASTM D3951.

5.3 Marking. In addition to any special markings required by the contract or order, each unit and shipping container shall be marked in accordance with MIL-STD-129.

6. NOTES

(This section contains information of a general or explanatory nature that may be helpful, but is not mandatory.)

6.2 Acquisition requirements. Acquisition documents must specify the following:

- a. Title, number, and date of the specification.
- b. Issue of DODISS to be cited in the solicitation, and if required, the specification issue of individual documents references (see 2.1).
- c. Level of packaging and packing required (see section 5).

6.2.1 Intended use. The hand pumps covered by this specification are intended for use in aircraft type I hydraulic systems conforming to and as defined in MIL-H-5440.

6.3 Qualification. With respect to products requiring qualification, awards will be made only for products which are at the time set for opening of bids, qualified for inclusion in the applicable Qualified Products List whether or not such products have actually been so listed by that date. The attention of the supplier is called to this requirement, and manufacturers are urged to arrange to have the products that they propose to offer to the Federal Government tested for qualification in order that they may be eligible to be awarded contracts or orders for the products covered by this specification. The activity responsible for the Qualified Products List is OC-ALC/TIMLA, Tinker Air Force Base, Oklahoma 73145-5990 and information pertaining to qualification of products may be obtained from that activity.

6.4 Subject term (key word) listing.

Aircraft
Pressure class 1500, class 3000
Type I system

6.5 Changes from previous issue. Marginal notations are not used in this revision to identify changes with respect to the previous issue due to the extensiveness of the changes.

Custodians:
Air Force - 99
Navy - AS
Army - AV

Preparing Activity:
Air Force - 71

Project number:
4320-0329

STANDARDIZATION DOCUMENT IMPROVEMENT PROPOSAL

INSTRUCTIONS

1. The preparing activity must complete blocks 1, 2, 3, and 8. In block 1, both the document number and revision letter should be given.
2. The submitter of this form must complete blocks 4, 5, 6, and 7.
3. The preparing activity must provide a reply within 30 days from receipt of the form.

NOTE: This form may not be used to request copies of documents, nor to request waivers, or clarification of requirements on current contracts. Comments submitted on this form do not constitute or imply authorization to waive any portion of the referenced document(s) or to amend contractual requirements.

RECOMMEND A CHANGE	1. DOCUMENT NUMBER MTL-P-5515D	2. DOCUMENT DATE (YYMMDD) 91/03/14
3. DOCUMENT TITLE Pump, Hydraulic, Ram, Hand Driven.		
4. NATURE OF CHANGE (Identify paragraph number and include proposed rewrite, if possible. Attach extra sheets as needed.)		
5. REASON FOR RECOMMENDATION		
6. SUBMITTER		
a. NAME (Last, First, Middle Initial)	b. ORGANIZATION	
c. ADDRESS (Include Zip Code)	d. TELEPHONE (Include Area Code) (1) Commercial (2) AUTOVON (If applicable)	7. DATE SUBMITTED (YYMMDD)
8. PREPARING ACTIVITY		
a. NAME OC-ALC/TIMLA	b. TELEPHONE (Include Area Code) (1) Commercial 405-736-7495	(2) AUTOVON
c. ADDRESS (Include Zip Code) Tinker AFB OK 73145-5990	IF YOU DO NOT RECEIVE A REPLY WITHIN 45 DAYS, CONTACT: Defense Quality and Standardization Office 5203 Leesburg Pike, Suite 1403, Falls Church, VA 22041-3466 Telephone (703) 756-2340 AUTOVON 289-2340	