

MIL-P-18066C  
31 July 1985  
SUPERSEDING  
MIL-P-18066B  
14 May 1965  
(See 6.5)

## MILITARY SPECIFICATION

### PLYWOOD, SHIP AND BOAT CONSTRUCTION

This specification is approved for use by all Departments and Agencies of the Department of Defense.

#### 1. SCOPE

1.1 Scope. This specification covers three classes of plywood for ship and boat building and special applications.

1.2 Classification. Plywood shall be of the following classes, as specified (see 6.2.1):

Class 1 - Douglas fir.

Class 2 - Mahogany.

Class 3 - Overlaid Douglas fir (medium density overlay both faces).

#### 2. APPLICABLE DOCUMENTS

##### 2.1 Government documents.

2.1.1 Specification and standards. Unless otherwise specified, the following specification and standards of the issue listed in that issue of the Department of Defense Index of Specifications and Standards (DoDISS) specified in the solicitation form a part of this specification to the extent specified herein.

#### SPECIFICATION

##### MILITARY

MIL-I-45208 - Inspection System Requirements.

##### FEDERAL

QQ-S-781 - Strapping, Steel, and Seals.

Beneficial comments (recommendations, additions, deletions) and any pertinent data which may be of use in improving this document should be addressed to: Commander, Naval Sea Systems Command, SEA 5523, Department of the Navy, Washington, DC 20362-5101 by using the self-addressed Standardization Document Improvement Proposal (DD Form 1426) appearing at the end of this document or by letter.

FSC 5530

DISTRIBUTION STATEMENT A Approved for public release; distribution unlimited

MIL-P-18066C

STANDARDS

MILITARY

MIL-STD-105 - Sampling Procedures and Tables for Inspection by Attributes.

MIL-STD-129 - Marking for Shipment and Storage.

2.1.2 Other Government documents. The following other Government document forms a part of this specification to the extent specified herein.

NATIONAL BUREAU OF STANDARDS

PS-1 - Construction and Industrial Plywood

(Copies of specifications, standards and publications required by contractors in connection with specific acquisition functions should be obtained from the contracting activity or as directed by the contracting officer.)

2.2 Other publications. The following documents form a part of this specification to the extent specified herein. The issues of the documents which are indicated as DoD adopted shall be the issue listed in the current DoDISS and the supplement thereto, if applicable.

AMERICAN SOCIETY FOR TESTING AND MATERIALS (ASTM)

D 3043 - Standard Methods of Testing Plywood in Flexure.

(Application for copies should be addressed to the American Society for Testing and Materials, 1916 Race Street, Philadelphia, PA 19103.)

HARDWOOD PLYWOOD MANUFACTURERS ASSOCIATION

ANSI/HPMA HP 1983 - American National Standard for Hardwood and Decorative Plywood.

(Application for copies should be addressed to Hardwood Plywood Manufacturers Association, 1825 Michael Faraday Drive, P.O. Box 2789, Reston, VA 22090-2789.)

(Industry association specifications and standards are generally available for reference from libraries. They are also distributed among technical groups and using Federal agencies.)

2.3 Order of precedence. In the event of a conflict between the text of this specification and the references cited herein, the text of this specification shall take precedence.

3. REQUIREMENTS

3.1 General requirements. The requirements specified in 3.1.1 through 3.1.13 shall apply to all classes of plywood (see 1.2). Additional requirements applicable to individual classes of plywood shall be as specified in 3.2.

3.1.1 Construction. Plywood shall be constructed with an odd number of veneers or plies. All plies, except the core or center ply, shall occur in pairs. The two plies of each pair shall be of the same thickness and direction

## MIL-P-18066C

of grain, and shall be placed on opposite sides of the core. The grain of all plies shall be at right angles to the grain of adjacent plies. The general grain direction of the face veneers,<sup>1</sup> shall be parallel to the length of the panel (see figure 1). Face plies of rotary cut veneer shall be bonded tight side out. Face plies of sliced or sawn veneer may be book-matched (book-matched and tight side are defined in ANSI/HPMA HP 1983). Veneer shall be tight, smoothly cut and uniform in thickness. Veneers within a ply shall be of the same thickness. The thickness of plies with grain direction parallel to faces shall total 40 to 60 percent of panel thickness, except on 3-ply constructions.

3.1.2 Bonding. The assembled veneers, panel scarf joints, panel repairs and overlays, shall be bonded under heat and pressure with synthetic resin glue of the phenol or resorcinol type.

3.1.3 End-grain joints. Butted or scarfed end-grain joints shall not be permitted in any ply.

3.1.4 Edge-grain joints. When the faces or any ply running parallel with the faces consist of two or more pieces of veneer, the edges shall be joined straight, square and tight, and shall be adhesive bonded prior to panel pressing. When the cross band veneers consist of two or more pieces of veneer, the edges shall be jointed straight and square without overlapping. Staples or tape which will be retained in the trimmed panel shall not be used to join veneers. Tape or staples may be used in trim zones for temporarily holding veneers during edge gluing or pressing.

3.1.5 Gaps and splits in cross bands. No putty, fillers, wood plugs, slivers or other concealment of gaps and splits in panels shall be used. Layout of plies shall be tight and ply quality shall be such that gaps or splits shall not exceed, after pressing and trimming, 1/4 inch combined total width, 1/8 inch maximum individual width or a total of four in number per cross band ply edge per 8 feet of panel length. Gaps and splits exceeding 1/16 inch shall not be superimposed within 1/2 inch.

3.1.6 Moisture content. The moisture content of the finished plywood at the time of shipment from the producer's mill or as acquisitioned from a local distributor shall be not less than 5 percent nor more than 15 percent, and the difference between face and center plies shall not exceed 2 percent when tested as specified in 4.3.4. The moisture shall be uniformly distributed and shall not vary more than 2 percent throughout the length and thickness of the panel.

3.1.7 Panel scarf joints. Plywood panels longer than 96 inches or wider than 60 inches may be made from two or more smaller panels by scarfing. Panel scarf joints shall not have a slope steeper than 1 in 8.

---

<sup>1</sup> When the terms "faces", "face ply" and "face veneers" are used, face and back veneers are implied.

## MIL-P-18066C

3.1.7.1 Scarf joint quality. When tested as specified in 4.3.5, average joint efficiency for panels shall be not less than 70 percent with no individual panel less than 60 percent.

3.1.8 Dimensional tolerance. Trimmed panels shall be within the dimensional, squareness and straightness tolerances shown in table I.

TABLE I. Panel dimensional, squareness and straightness tolerances measured to nearest 1/32 inch.

	Inches
Width	+1/32, -1/16
Length	
12 feet and under	±1/16
Over 12 feet	+1/8, -1/16
Thickness	See 3.2.5
Squareness	Measured at each end of panel: panels less than 4 feet in length or width shall be square within 1/16 inch. Panels 4 feet or greater in length or width shall be square within 1/64 inch per linear foot.
Straightness of edge or end	Any point along an edge or end shall be within 1/16 inch of a straight line between any two adjacent corners.

3.1.9 Marking. Each plywood panel shall be marked on the edges or ends with manufacturer's name or trademark, the number of this specification (with amendment, if applicable) and the class of plywood (see 1.2).

3.1.10 Storage. Plywood shall be stored under cover at all times.

3.1.11 Boil shear resistance. The plywood shall develop an average wood failure of not less than 75 percent and no more than 1/10 of the values obtained shall fall below 50 percent wood failure for each panel tested as specified in 4.3.1.

3.1.12 Dry shear strength. The plywood shall develop an average shear strength of not less than 180 pounds per square inch (lb/in<sup>2</sup>) for each panel tested as specified in 4.3.2.

3.1.13 Heat durability and delamination resistance. When tested as specified in 4.3.3 the plywood shall show no glue-line delamination due to combustion or heat.

## MIL-P-18066C

3.2 Individual classes of plywood. In addition to the requirements specified in 3.1, the following requirements apply to the individual classes of plywood covered by this specification:

3.2.1 Species. Plywood may be of any species in table II for the class indicated. Plies of each panel shall be of the same species. Unless otherwise specified (see 6.2.1), the shipment may contain one or more of the class species.

TABLE II. Species.

Plywood class included	Commercial designation	Common name	Scientific name	Origin
1	Coastal Douglas fir	Douglas fir	<i>Pseudotsuga menziesii</i>	Western United States and Canada (western half of California, Oregon, Washington and British Columbia)
	Western larch	Western larch	<i>Larix occidentalis</i>	Idaho, Montana, eastern Washington
2	American, Honduras, or Central American mahogany	Mahogany	<i>Swietenia macrophylla</i> or <i>S. mahagoni</i>	Mexico, West Indies, Central America, South America
	African mahogany	Khaya	<i>Khaya ivorensis</i> <i>K. anthotheca</i> <i>K. senegalensis</i> <i>K. grandifolia</i>	West Africa
	Philippine mahogany (dark red lauan species)	Tangile Red lauan Tiaong	<i>Shorea polysperma</i> <i>S. negrosensis</i> <i>S. teysmaniana</i>	Philippine Islands
3	Same as class 1			

3.2.2 Heartwood. Veneers, patches and repairs shall be heartwood only (see 4.3.6). Panels to be pressure-treated with preservative may permit sapwood when specified (see 6.1.1 and 6.2.1).

## MIL-P-18066C

3.2.3 Veneer quality and defect repair. Veneer quality and defect repair shall be in accordance with table III.

TABLE III. Veneer quality and defect repairs.

Plywood class	Ply	Veneer quality	Applicable publications	Defect repairs	Exceptions to applicable specification
1	Face	Suitable for paint finish grade A (marine quality)	PS-1 (marine)	Patches Plugs Shims	Not more than six single defect repairs in 32 square feet panel, proportionate to area in other panel sizes. Shim length 24 inches (maximum) (Applies to panels prior to scarfing).
	Inner	Grade B (marine quality)	PS-1 (marine)	No exceptions to PS-1	
2	Face	Suitable for natural finish B Grade (B)	ANSI/HMPA HP 1983 (Technical type plywood)	Patches Plugs Shims	Not more than four inconspicuous, well matched, small patches not exceeding 3/8 inch wide by 2½ inches long are permitted. Shims not greater than 3/16 inch wide and 12 inches long are permitted on ends of panels only. (Applies to panels prior to scarfing).
	Inner	Sound grade (2)	ANSI/HMPA HP 1983 (Technical type plywood)	No doze or decay permitted.	

## MIL-P-18066C

TABLE III. Veneer quality and defect repairs. - Continued

Plywood class	Ply	Veneer quality	Applicable publications	Defect repairs	Exceptions to applicable specification
3	Under overlay	Grade B (marine quality)	PS-1 (marine)	Plugs Patches Shims	No knots over 1/4 inch and no pitch pockets. No pitch streaks wider than 1/4 inch. No core gaps or splits.
	Inner	Grade B (marine quality)	PS-1 (marine)	No exceptions to PS-1	

3.2.4 Veneer thickness. No ply shall be thicker than nominal 1/8 inch before pressing. Nominal veneer thicknesses before pressing are to allow the normal commercial tolerance when cutting 1/8, 1/10, 1/12 and 1/16-inch veneer. Face ply thickness shall be in accordance with table IV. Approximately equal face ply thickness shall be maintained after sanding (see 3.2.5).

TABLE IV. Face ply thickness.

Plywood class	Panel thickness	Face ply thickness before pressing
	(Inch)	(Inch)
1 and 2	3/8 and thicker	1/10 minimum
3	1/4 and thicker	1/8 maximum

3.2.5 Panel thickness tolerance surface finish. Plywood without an overlay shall be sanded clean, even and smooth. There shall be no evidence of tool marks or sander streaks on sanded surface. Finished panels shall meet the requirements of table V.

TABLE V. Panel thickness tolerance requirements.

Plywood class	Thickness, tolerance, (inch)
1 and 2	3/4 inch thickness and less = as specified $\pm$ 1/64 (.015) Over 3/4 inch thick = as specified $\pm$ 3 percent
3	13/16 inch thickness and less = as specified $\pm$ 1/32 (.030) Over 13/16 inch thick = as specified $\pm$ 5 percent

## MIL-P-18066C

3.2.6 Overlay. The overlay on class 3 plywood shall be in accordance with PS-1 for exterior medium density overlay intended for high grade paint finish. The overlay shall be applied to both faces of the plywood.

3.2.6.1 Overlay bond. When tested as specified in 4.3.7.1, the overlay shall not delaminate from the plywood. There shall be no bulging or blistering of the overlay indicative of unbonded zone. There shall be no separation of the overlay at the edges of the specimen.

3.2.6.2 Overlay water absorption. The overlay shall not absorb more than 50 grams of water per square foot of single surface when tested as specified in 4.3.7.2.

3.2.6.3 Overlay checking resistance. When tested as specified in 4.3.7.3, the overlay shall not check when nailed with six-penny nails and shall show a maximum of 1/8 inch checking when nailed with eight-penny nails.

#### 4. QUALITY ASSURANCE PROVISIONS

4.1 Responsibility for inspection. Unless otherwise specified in the contract or purchase order, the contractor is responsible for the performance of all inspection requirements as specified herein. Except as otherwise specified in the contract or purchase order, the contractor may use his own or any other facilities suitable for the performance of the inspection requirements specified herein, unless disapproved by the Government. The Government reserves the right to perform any of the inspections set forth in the specification where such inspections are deemed necessary to assure supplies and services conform to prescribed requirements.

4.1.1 Inspection system. When specified in the contract or order (see 6.2.1), the contractor shall provide and maintain an inspection system in accordance with MIL-I-45208 and the data ordering document specified in 6.2.2.

#### 4.2 Quality conformance inspection sampling.

4.2.1 Lot for surface examination and testing. A lot shall consist of plywood panels of the same class produced at one manufacturing plant and offered for inspection at one time.

4.2.2 Lot for inspection of packaging. A lot shall consist of one carload or truckload quantity or less, for shipment to one destination.

4.2.3 Surface examination. The quantity of plywood in the lot shall be determined by tally in accordance with commercial practice. Sample panels shall thereafter be selected by random sampling from the lot in accordance with table VI. Each sample panel shall be examined for conformance with 3.1 and 3.2, excepting those requirements which involve tests. Any sample panel which does not meet requirements shall not be offered for delivery, and if the number of such pieces found in any sample exceeds the acceptance number in table VI for that sample, this shall be cause for rejection of the lot represented by the sample.



## MIL-P-18066C

TABLE VI. Sampling for surface examination acceptable quality level (AQL) = 4.0 percent (approximate) nonconforming.

Lot size number of panels	Sample size number of panels	Acceptance number (defectives)	Rejection number (defectives)
Up to 110	15	1	2
111 to 180	25	2	3
181 to 500	35	3	4
501 to 800	50	4	5
801 to 1300	75	6	7
1301 to 3200	110	8	9
3201 and over	150	11	12

4.2.4 Testing. The applicable tests specified in 4.3 shall be performed on test panels specified in 4.2.4.1.

4.2.4.1 Test panels. Sample panels shall be selected at random from each lot in accordance with table VII for the tests specified in 4.3. For lots containing scarfed panels, random sampling (see table VII) may be done prior to scarfing of panels and separately scarfed panels prepared as specified in 4.2.4.1.2.

TABLE VII. Sampling for testing.

Lot size. Number of panels in lot	Sample size. Number of test panels
40 and under	2
41 to 65	4
66 to 110	6
111 to 300	8
301 to 800	10
801 to 3200	12
3201 to 8000	14

4.2.4.1.1 Preparation of unscarfed test panels. From each panel selected in 4.2.4.1, a test panel shall be cut full width by 2-feet long and shall be identified as specified in 4.2.4.1.3.

4.2.4.1.2 Preparation of scarfed test panels. From each panel selected in 4.2.4.1, a piece shall be cut full width by 2-feet long and shall be identified as specified in 4.2.4.1.3. Each 2-foot piece shall be scarfed to another piece from the lot to make a scarfed test panel 42 inches (minimum) long by the full panel width as specified on figure 2. The scarf joint shall be made by the same process, equipment and adhesives used in production of scarfed panels of the lot, and shall be bonded along with the lot.

## MIL-P-18066C

4.2.4.1.3 Identification of test panels and test samples. Each lot, test sample and specimen shall be given an appropriate marking in indelible ink to identify the lot, test sample and specimen representing the lot. Markings shall be such as will facilitate comparison and analysis of the examination and test results.

4.3 Tests. After it has been determined that the examinations of 4.2.3 have been met, each sample panel shall be subjected to the tests listed in table VIII for the applicable class of plywood.

TABLE VIII. Tests.

Plywood class	Scarfs		Boil shear 4.3.1	Dry shear 4.3.2	Heat durability (delam) 4.3.3	Moisture content 4.3.4	Scarf test 4.3.5	Heart-wood 4.3.6	Over-lay 4.3.7
	None	With							
1, 2	X		X	X	X	X		X	
		X	X	X	X	X	X	X	
3	X		X	X	X	X		X	X
		X	X	X	X	X	X	X	X

4.3.1 Boil shear test. Ten shear test specimens shall be taken from each test panel and shall be subjected to the boil test as described in PS-1. The two center gluelines shall be tested in 50 to 75 percent of the test specimens (see figures 3 and 4). Any specimen showing delamination in excess of 1/8 inch deep and 1/2 inch long shall be rated as zero percent wood failure. Delamination shall be evaluated at the end of the drying cycle of the boil test. Average wood failure shall be determined for each test panel. In case of failure, 10 additional samples from the same panel may be tested. Original and retest results shall be averaged.

4.3.2 Dry shear test. Five shear test specimens shall be taken from each test panel and shall be tested dry employing the means of testing described in PS-1. The two center gluelines shall be tested in 50 to 75 percent of the test specimens. In case of failure, five additional specimens from the same sample may be tested. Results of original tests and retests shall be averaged. Average shear strength shall be calculated for each test panel.

4.3.3 Heat durability test. One fire test specimen shall be taken at random from any test panel representative of one lot. Testing shall be performed in accordance with PS-1. If the one specimen fails the test, this shall be cause for rejection of the entire lot.

4.3.4 Moisture test. Moisture content of face and center ply shall be measured on each test panel at a location at least 8 inches from edges. A resistance type moisture meter may be used during inspection for determining moisture content on untreated plywood. The prongs shall be driven 1/16-inch

## MIL-P-18066C

into the face ply and a reading taken. Thereupon the prongs shall be driven to the center of the panel and a reading taken. The oven method shall be used for treated plywood and for all laboratory testing by cutting sections of face ply and center ply.

4.3.5 Scarf test. Six unscarfed and six scarfed test specimens shall be taken from each test panel selected in accordance with 4.2.4.1 or prepared as specified in 4.2.4.1.1 and 4.2.4.1.2. The test specimens shall be 2 inches wide and 14 inches long and shall be randomly distributed (see figure 2). The test specimens shall be conditioned in accordance with the vacuum-soak test of PS-1 except that after heating to 120 degrees Fahrenheit (°F), the soak shall continue at room temperature for 48 hours. The scarfed test specimen shall be center loaded over a 12-inch span with the feather edge of the scarf located on the tension face at the point of load application. The static bending test of ASTM D 3043, method A shall be conducted on the wet test specimens to determine the scarf joint efficiency.<sup>2</sup> One retest will be allowed in case of failure. If retested, the results shall be the average of the first plus second tests. Joint efficiency shall be determined for each panel.

4.3.6 Heartwood. Sample panels selected in 4.2.3 and 4.2.4.1 shall be visually examined on all edges, ends and faces for the presence of sapwood. If any ply contains sapwood greater than 1-inch wide across the grain (parallel to the annual rings) that panel shall be rejected. If more than one panel is rejected the lot represented by that sample shall be rejected. Identification of sapwood of Douglas fir can be made by application of a 0.75 percent water solution of alizarine-sulphate (Alizarine Red-5) which stains heartwood yellow sapwood pink or other shade of red. If the heartwood only requirement is not applicable (see 6.1.1 and 6.2.1), testing for sapwood is not required.

4.3.7 Overlay tests. The sample panels of class 3 plywood shall be subjected to the bonding test, water absorption and checking (nailing) test of 4.3.7.1, 4.3.7.2 and 4.3.7.3, respectively.

4.3.7.1 Bonding test. The boil shear test specimens of 4.3.1 shall be examined immediately before shearing. Specimens which show that the performance of the overlay has been affected by allowable defects in the ply under the overlay shall be disregarded provided that not more than two specimens from a sample panel are discarded. If more than two specimens are so eliminated an additional five specimens shall be cut at random and subjected to the boiling-drying procedure of 4.3.1 and 4.3.2, then evaluated as for original 10 specimens. The combined sampling shall consist of at least 10 specimens per sample panel. Not more than one specimen per panel shall show nonconformance to the bonding requirement of 3.2.6.1.

---

<sup>2</sup> Scarf joint efficiency (percent) = 
$$\frac{\text{Average maximum load at failure (scarf specimens X 100)}}{\text{Average maximum load at failure (unscarfed specimens)}}$$

MIL-P-18066C

4.3.7.2 Water absorption. One specimen 4-1/2 by 4-1/2 inches square shall be cut from each sample panel. At the time of test, moisture content shall be 5 to 8 percent as determined in 4.3.4. The corners and edges shall be rounded. The edges shall be sealed by dipping repeatedly in a molten mixture (50:50) of beeswax and rosin until a continuous seal is attained. The edges shall be dipped just far enough to produce an unsealed face area of 4 by 4 inches. Each edge sealed specimen shall be weighed to nearest 0.01 gram, then immersed in fresh tap water at 70 to 80°F for 48 hours. A rack shall be used to separate specimens during immersion. At the end of the immersion period, each specimen shall be wiped with a towel and allowed to stand until the surface moisture is not visible (not more than 5 minutes). Weigh each specimen to nearest 0.01 gram to determine weight of water absorbed. Convert weight of water absorbed per specimen to weight of water absorbed per square foot of single surface.

$$W = w \times \frac{144}{A + B}$$

Where W = weight of water absorbed per square foot of single surface (grams).

w = weight absorbed per specimen (grams).

A = area of one absorption face of specimen (square inches).

B = area of opposite absorption face of specimen (square inches).

4.3.7.3 Checking (nailing) test. One nailing test specimen approximately 8 inches with the grain of the ply under the overlay by approximately 18 inches across the grain shall be cut from each sample panel. Three six-penny box nails (bright, diameter 0.088 inch) and three eight-penny common nails (bright, diameter 0.130-inch) shall be driven at 3-inch intervals along a line perpendicular to the grain direction of the ply under the overlay. The nails shall penetrate perpendicular to the surface of the plywood and through both faces of the plywood. During nailing, the specimen shall be placed on a softwood block which is solidly supported to eliminate excessive bending and vibration. Immediately after driving, the condition of the overlay about the nails shall be noted. Any checks that may have occurred on the fronts or backs of the specimens shall be measured and recorded. The nails shall be removed from each specimen with a claw hammer; then the holes shall be inspected for separation of the overlay from the plywood. Any cracks in the overlay caused by splintering of the plywood shall not be considered checking of the overlay and shall be disregarded.

4.4 Examination of packaging. For examination of packaging, a sample unit shall consist of a unit pack of plywood. For each lot defined in 4.2.2, a sample consisting of the required number of sample units shall be selected in accordance with MIL-STD-105, inspection level S-3 with an acceptable quality level of 6.5 percent defective. Each sample unit shall be examined to determine compliance with the applicable packaging requirements specified herein. Any evidence of noncompliance with marking, packaging and packing requirements shall be cause for classifying the sample unit defective. If the number of defective sample units exceeds the acceptance number, this shall be cause for rejection of the entire lot.

## 5. PACKAGING

5.1 Packing. Packing shall be level A, B or C as specified (see 6.2.1), except that unit loads shall not exceed 2,000 pounds on export packs. Panels shall not be subjected to other than covered storage while awaiting shipment or at any stopover point in transit.

5.1.1 Level A. Plywood of one length, width, thickness and description shall be packed as shown on figure 5, except that to complete a shipment, the last pack of each size and description of plywood may contain a lesser number of panels than shown in table A of figure 5. Plywood shall be stacked so as to provide a square edge on one end and one side of each pack, with the face side of the top and bottom panels toward the center of the pack. All surfaces of the stack shall be protected by waster sheets of 1/4-inch or thicker plywood, placed as shown on figure 5. For packages over 96 inches in length, side waster sheets shall be plywood or lumber not less than 3/4-inch thick. Strapping shall be in accordance with type I, finish A or B of QQ-S-781, size and location as shown on figure 5, except that all packages over 144 inches long shall require a fourth girthwise strap. The third and fourth girthwise straps shall be positioned equal girthwise distances from the end straps and from each other. When specified (see 6.2.1), wood battens shall be applied under each girthwise strap as noted on figure 5. Corner protectors shall be used at all corners under the straps except on ends of battens. Packs shall be closely packed and the straps shall be properly tensioned and sealed.

5.1.2 Level B. Plywood of one length, width, thickness and description shall be packed as shown on figure 6, except that to complete a shipment, the last pack of each size and description of plywood may contain a lesser number of panels than shown in table A of figure 6. Plywood shall be stacked so as to provide a square edge on one end and one side of each pack, with the face side of the top and bottom panels toward the center of the pack. The top and bottom of each stack shall be protected by waster sheets of 1/4-inch or thicker plywood, placed as shown on figure 6. Waster sheets shall be the same size (length and width) as plywood in the pack. Strapping shall be in accordance with type I, finish A or B of QQ-S-781, size and location as shown on figure 6, except packages over 144 inches in length shall require 4 girthwise straps. When specified (see 6.2.1) wood battens shall be applied under each girthwise strap as noted on figure 6. Corner protectors shall be used at all corners under the straps except on ends of battens. Packs shall be closely packed, and the straps shall be properly tensioned and sealed.

5.1.3 Level C. Plywood panels shall be loaded and assembled in the closed car or truck. The classes and sizes shall be adequately segregated and appropriately identified. On less car loads (LCL) or less truck loads (LTL) the exposed face surfaces of the bottom and top pieces of each pile shall be protected from damage by the use of waster sheets or water-resistant fiberboard. Loading shall be in a manner to insure carrier acceptance and safe delivery at destination and in accordance with the carriers rules and regulations.

5.2 Loading. Rail shipment of plywood shall be loaded in box cars. Truck shipment shall be protected from the weather. The floor of the car or truck shall be stripped with sufficient spacers not less than 3 by 6 inches in size to permit forklift unloading, unless wood battens integral to the package are required (see 5.1.1, 5.1.2 and 6.2.1).

## MIL-P-18066C

5.3 Marking. In addition to any special marking specified (see 6.2.1), shipments shall be marked in accordance with MIL-STD-129.

## 6. NOTES

6.1 Intended use. The plywood furnished under this specification is of the quality necessary for boat and ship construction and for special applications on vital equipment for extreme environments. It is not intended for general construction where commercial exterior grades can be used. Distinguishing quality features under this specification provide: decay resistance, limitation of defects affecting strength and paint serviceability and ply construction necessary for marine exposure to insure necessary stiffness and resistance to ply delamination.

6.1.1 Sapwood restriction. When it is known that plywood of classes 1, 2 or 3 are to be pressure preservative treated after manufacturing,<sup>3</sup> the sapwood restriction is not required (see 3.2.2 and 6.2.1).

6.2 Ordering data.

6.2.1 Acquisition requirements. Acquisition documents should specify the following:

- (a) Title, number and date of this specification.
- (b) Class required (see 1.2).
- (c) Species in table II, if any of listed species are not to be included (see 3.2.1).
- (d) Whether the heartwood requirement applies (see 3.2.2, 4.3.6 and 6.1.1).
- (e) Level of packing required (see 5.1).
- (f) Whether battens are required on packs of plywood (see 5.1.1, 5.1.2 and 5.2).
- (g) Special marking for shipment required (see 5.3).
- (h) Thickness, length and width of panels (see 6.3).
- (i) Whether an inspection system is required (see 4.1.1).

6.2.2 Data requirements. When this specification is used in an acquisition which incorporates a DD Form 1423, Contract Data Requirements List (CDRL), the data requirements identified below shall be developed as specified by an approved Data Item Description (DD Form 1664) and delivered in accordance with the approved CDRL incorporated into the contract. When the provisions of FAR 52.227-7031 are invoked and the DD Form 1423 is not used, the data specified below shall be delivered by the contractor in accordance with the contract or purchase order requirements. Deliverable data required by this specification is cited in the following paragraph.

<u>Paragraph no.</u>	<u>Data requirement title</u>	<u>Applicable DID no.</u>	<u>Option</u>
4.1.1	Inspection system program plan	DI-R-4803	----

<sup>3</sup> Such as MIL-P-19550 - preservative treatment, plywood.

## MIL-P-18066C

(Data item descriptions related to this specification, and identified in section 6 will be approved and listed as such in DoD 5000.19L., Vol. II, AMSDL. Copies of data item descriptions required by the contractors in connection with specific acquisition functions should be obtained from the Naval Publications and Forms Center or as directed by the contracting officer.)

6.2.2.1 The data requirements of 6.2.2 and any task in sections 3, 4, or 5 of this specification required to be performed to meet a data requirement may be waived by the contracting/acquisition activity upon certification by the offeror that identical data were submitted by the offeror and accepted by the Government under a previous contract for identical item acquired to this specification. This does not apply to specific data which may be required for each contract regardless of whether an identical item has been supplied previously (for example, test reports).

6.3 Panel sizes. Use of available sizes of plywood as shown in table IX will prevent delays and added costs.

TABLE IX. Commercially available sizes.

Item	Width (inches)	Lengths (inches)		Thickness (inches)	
Stock panels <sup>1</sup>	24	48	144	<sup>2</sup> 1/8	3/4
	30	60	168	<sup>2</sup> 3/16	7/8
	36	72	192	1/4	1
	48	84	240	5/16	1-1/8
	60	96		3/8	1-1/4
			108		1/2
		120		5/8	

<sup>1</sup> Wider width or longer lengths to order.

<sup>2</sup> May not be commonly available in classes 1 and 3.

6.4 Definitions. Definitions of defects used herein may be found in PS-1 or ANSI/HMPA HP 1983.

MIL-P-18066C

6.5 Changes from previous issue. Asterisks are not used in this revision to identify changes with respect to the previous issue, due to the extensiveness of the changes.

Custodians:

Army - ME  
Navy - SH  
Air Force - 99

Preparing activity:  
Navy - SH  
(Project 5530-0037)

Review activities:

Air Force - 69  
DLA - CS

User activities:

Army - MR  
Navy - MC, YD



MIL-P-18066C

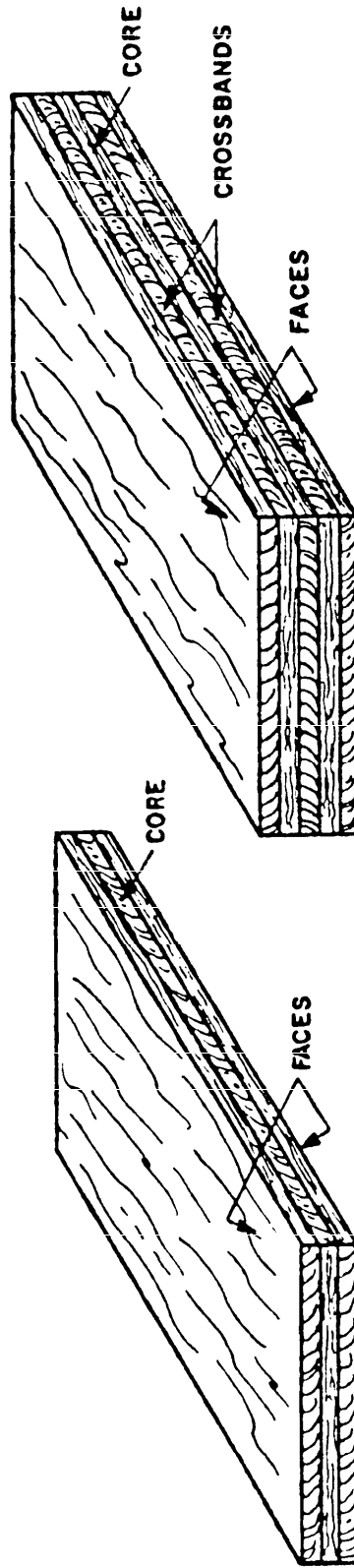

**FIVE-PLY CONSTRUCTION  
WITH VENEER CORE**

**THREE-PLY CONSTRUCTION  
WITH VENEER CORE**

**FIGURE 1. Plywood construction.**

SH 1799

MIL-P-18066C

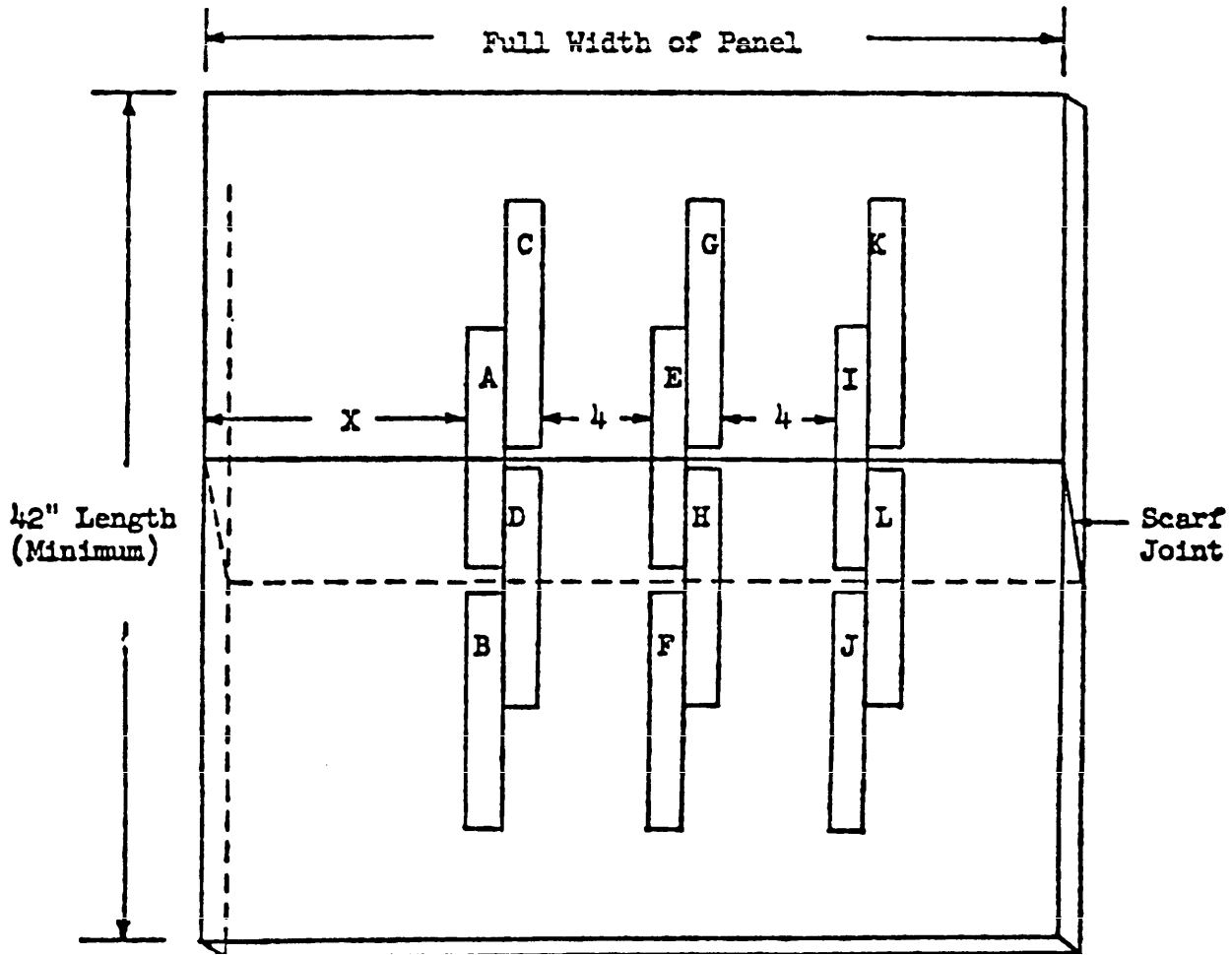

SH 12943

## NOTE:

1. The starting point (X) for laying out the first matched specimens (A and B) should be varied for each test sample to provide a random selection of specimens.

FIGURE 2. Typical cut-up plan for scarf joint specimen.

MIL-P-18066C

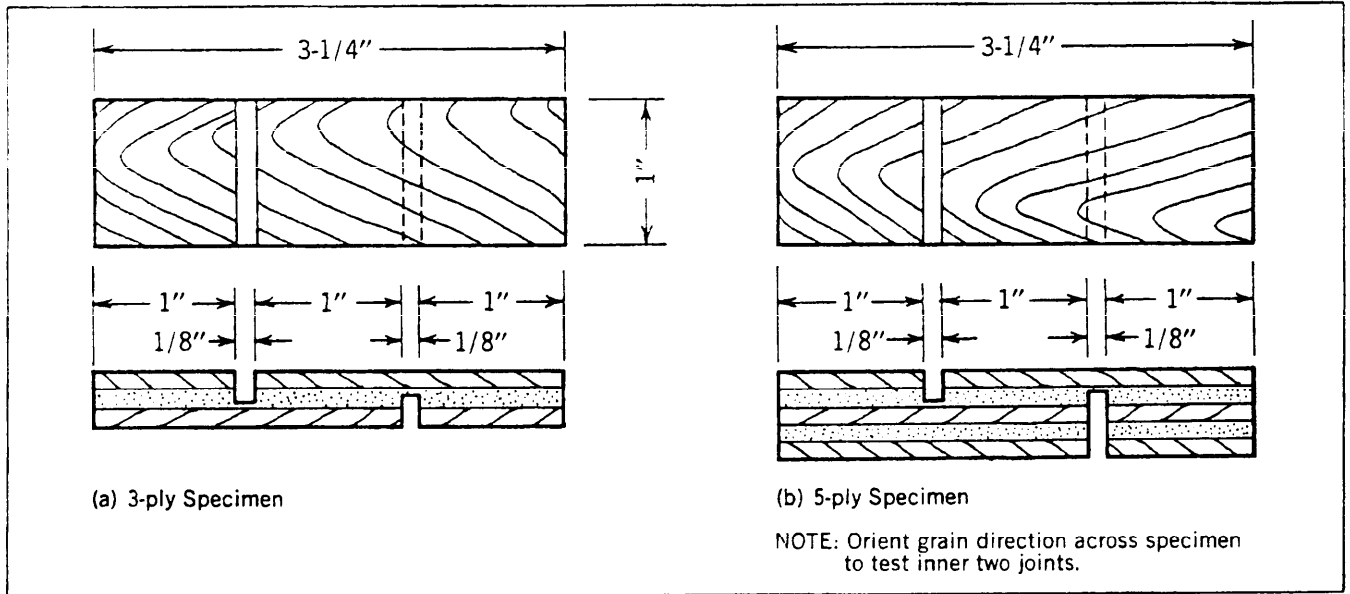

SH 12954

FIGURE 3. Test specimen.

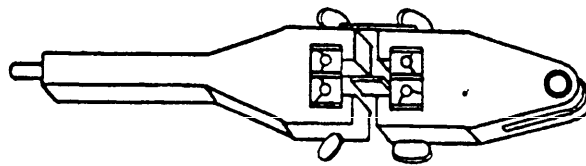

SH 111

FIGURE 4. Jaws for shear test.

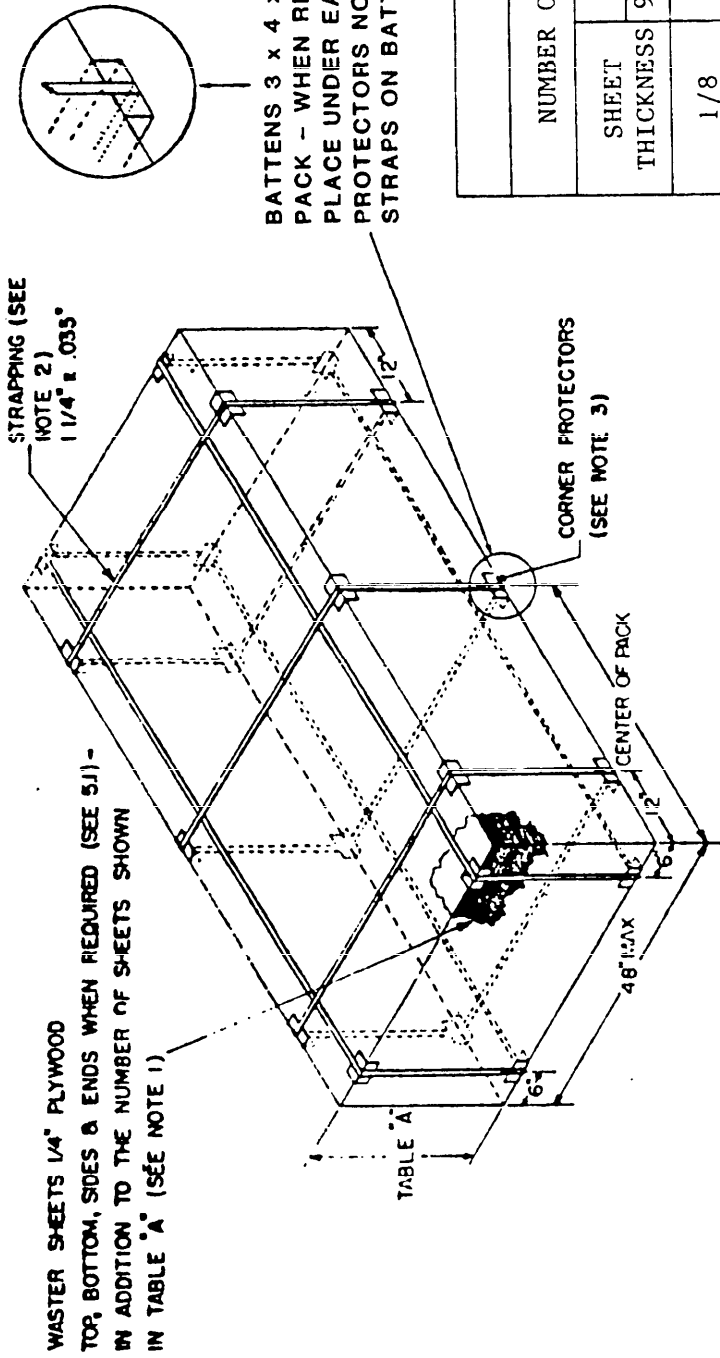

BATTENS 3 x 4 x FULL WIDTH OF PACK - WHEN REQUIRED (SEE 5.1.1) PLACE UNDER EACH STRAP. CORNER PROTECTORS NOT REQUIRED UNDER STRAPS ON BATTENS.

TABLE "A"		
NUMBER OF SHEETS PER PACK		
SHEET THICKNESS	SHEET LENGTH 96" AND UNDER OVER 96"	
1/8	192	96
3/16	128	64
1/4	96	48
5/16	76	38
3/8	64	32
1/2	48	24
9/16	42	20
5/8	38	18
3/4	32	16
13/16	28	14
7/8	26	12
1	24	12
1-1/8	20	10
1-1/4	18	9
1-1/2	16	8

SH 12944

NOTES:

1. Bottom waster sheet shall be nailed at two points to each batten (when battens are required) prior to assembly of pack.
2. Strapping: girthwise straps applied over lengthwise straps. Girthwise straps applied over battens (when battens are required) and stapled to battens every 6 inches with 3/4 inch leg, 14 gauge, cement coated staples.
3. Corner protectors: steel, not less than 3 inches in width, a leg length not less than 2 inches, not less than 0.041 inch in thickness, embossed vertical and horizontal ridges.

FIGURE 5. Level A packing.

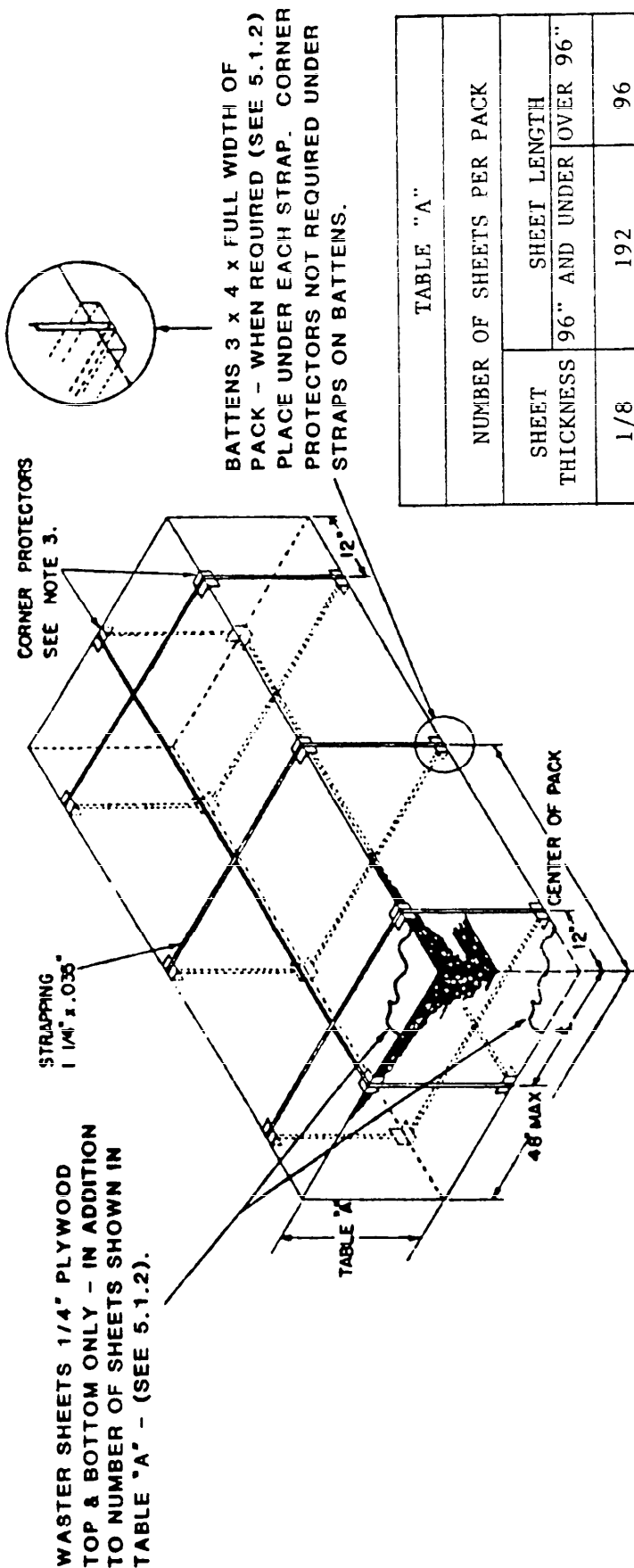

TABLE "A"

NUMBER OF SHEETS PER PACK	
SHEET THICKNESS	SHEET LENGTH 96" AND UNDER OVER 96"
1/8	192
3/16	128
1/4	96
5/16	76
3/8	64
1/2	48
9/16	42
5/8	38
3/4	32
13/16	28
7/8	26
1	24
1-1/8	20
1-1/4	18
1-1/2	16

SH 12945

NOTES:

1. When battens and waster sheets are both required, bottom waster sheet is nailed at two or more points to each batten, prior to assembly of pack.
2. Strapping: girthwise straps applied over lengthwise straps. When battens are required girthwise straps are applied over battens and stapled to battens every 6 inches with 3/4 inch leg, 14 gauge, cement coated staples.
3. Corner protectors: Steel, not less than 3 inches in width, a leg length not less than 2 inches, not less than 0.041 inch in thickness, embossed vertical and horizontal ridges.

FIGURE 6. Level B packing.

**INSTRUCTIONS:** In a continuing effort to make our standardization documents better, the DoD provides this form for use in submitting comments and suggestions for improvements. All users of military standardization documents are invited to provide suggestions. This form may be detached, folded along the lines indicated, taped along the loose edge (*DO NOT STAPLE*), and mailed. In block 5, be as specific as possible about particular problem areas such as wording which required interpretation, was too rigid, restrictive, loose, ambiguous, or was incompatible, and give proposed wording changes which would alleviate the problems. Enter in block 6 any remarks not related to a specific paragraph of the document. If block 7 is filled out, an acknowledgement will be mailed to you within 30 days to let you know that your comments were received and are being considered.

**NOTE:** This form may not be used to request copies of documents, nor to request waivers, deviations, or clarification of specification requirements on current contracts. Comments submitted on this form do not constitute or imply authorization to waive any portion of the referenced document(s) or to amend contractual requirements.

(Fold along this line)

(Fold along this line)

DEPARTMENT OF THE NAVY

COMMANDER  
NAVAL SEA SYSTEMS COMMAND (SEA 5523)  
DEPARTMENT OF THE NAVY  
WASHINGTON, DC 20362-5101



NO POSTAGE  
NECESSARY  
IF MAILED  
IN THE  
UNITED STATES

OFFICIAL BUSINESS  
PENALTY FOR PRIVATE USE \$300

**BUSINESS REPLY MAIL**  
FIRST CLASS PERMIT NO. 12503 WASHINGTON D C

POSTAGE WILL BE PAID BY THE DEPARTMENT OF THE NAVY

COMMANDER  
NAVAL SEA SYSTEMS COMMAND (SEA 5523)  
DEPARTMENT OF THE NAVY  
WASHINGTON, DC 20362-5101



## STANDARDIZATION DOCUMENT IMPROVEMENT PROPOSAL

*(See Instructions - Reverse Side)*

1. DOCUMENT NUMBER MIL-P-18066C	2. DOCUMENT TITLE PLYWOOD, SHIP AND BOAT CONSTRUCTION
3a. NAME OF SUBMITTING ORGANIZATION	4. TYPE OF ORGANIZATION <i>(Mark one)</i> <input type="checkbox"/> VENDOR  <input type="checkbox"/> USER  <input type="checkbox"/> MANUFACTURER  <input type="checkbox"/> OTHER <i>(Specify):</i> _____
b. ADDRESS <i>(Street, City, State, ZIP Code)</i>	
5. PROBLEM AREAS	
a. Paragraph Number and Wording:	
b. Recommended Wording:	
c. Reason/Rationale for Recommendation:	
6. REMARKS	
7a. NAME OF SUBMITTER <i>(Last, First, MI) - Optional</i>	b. WORK TELEPHONE NUMBER <i>(Include Area Code) - Optional</i>
c. MAILING ADDRESS <i>(Street, City, State, ZIP Code) - Optional</i>	8. DATE OF SUBMISSION <i>(YYMMDD)</i>