

INCH-POUND

MIL-N-25027/1A

28 April 1995

MIL-N-25027/1

14 July 1989

## MILITARY SPECIFICATION

NUT, SELF-LOCKING, HEAVY HEX, (NON-METALLIC INSERT) 250° and 450° F,  
UNJC-3B, 1/4 THROUGH 2-1/2 INCH NOMINAL DIAMETERS, NICKEL-COPPER ALLOY

This specification is approved for use by the Naval Sea Systems Command, Department of the Navy, and is available for use by all Departments and Agencies of the Department of Defense.

### 1. SCOPE

1.1 Scope. This specification covers the requirements for nickel-copper alloy, self-locking nuts.

### 2. APPLICABLE DOCUMENTS

#### 2.1 Government documents.

2.1.1 Specifications, standards, and handbooks. The following specifications, standards, and handbooks form a part of this document to the extent specified herein. Unless otherwise specified, the issues of these documents are those listed in the issue of the Department of Defense Index of Specifications and Standards (DODISS) and supplement thereto, cited in the solicitation (see 6.2).

## SPECIFICATIONS

### FEDERAL

QQ-N-281 - Nickel-Copper Alloy Bar, Rod, Plate, Sheet, Strip,  
Wire, Forgings, and Structural and Special Shaped Sections.

Beneficial comments (recommendations, additions, deletions) and any pertinent data which may be of use in improving this document should be addressed to: Defense Industrial Supply Center, 700 Robbins Avenue, (Code DISC-EED) Philadelphia, 19111-5096 by using the self-addressed Standardization Document Improvement Proposal (DD Form 1426) appearing at the end of this document or by letter.

AMSC N/A

FSC 5310

DISTRIBUTION STATEMENT A. Approved for public release; distribution is unlimited.

## MIL-N-25027/1A

## MILITARY

- MIL-S-8879 - Screw Threads, Controlled Radius Root With Increased Minor Diameter, General Specification for.  
 MIL-N-25027 - Nut, Self-Locking, 250 F, 450 F, and 800 F.  
 MIL-R-46198 - Resin, Polyimide, Hot Pressed and Sintered  
 MS17828 - Nut, Self-Locking, Hexagon, Regular Height (Non-Metallic Insert) 250 F Nickel Copper Alloy.

## STANDARDS

## FEDERAL

- FED-STD-H28 - Screw-Thread Standards for Federal Services.  
 FED-STD-H28/20 - Screw-Thread Standards for Federal Services Section 20 Inspection Methods for Acceptability of UN, UNR, UNJ, M, and MJ Screw Threads.

## MILITARY

- MIL-STD-271 - Requirements for Nondestructive Testing Methods.  
 MIL-STD-792 - Identification Working Requirements for Special Purpose Components.

(Unless otherwise indicated, copies of federal and military specifications, standards, and handbooks are available from the Defense Printing Service Detachment Office, (ATTN: DPSDO), 700 Robbins Avenue, Philadelphia, PA 19111-5096.)

2.2 Non-Government publications. The following document(s) form a part of this document to the extent specified herein. Unless otherwise specified, the issues of the documents which are DOD adopted are those listed in the issue of the DODISS cited in the solicitation. Unless otherwise specified, the issues of documents not listed in the DODISS are the issues of the documents cited in the solicitation (see 6.2).

## AMERICAN SOCIETY FOR TESTING AND MATERIALS (ASTM)

- A 370 - Standard Test Methods and Definitions for Mechanical Testing of Steel Products. (DoD adopted)  
 D 3951 - Standard Practice for Commercial Packaging.  
 D 4066 - Standard Specification for Nylon Injection and Extrusion Materials (PA). (DoD adopted)  
 E 76 - Standard Methods for Chemical Analysis of Nickel-Copper Alloys.  
 F 606 - Standard Test Methods for Determining the Mechanical Properties of Externally and Internally Threaded Fasteners, Washers, and Rivets. (DoD adopted)

(Application for copies should be addressed to the American Society for Testing and Materials, 1916 Race Street, Philadelphia, PA 19103.)

(Non-Government standards and other publications are normally available from the organizations that prepare or distribute the documents. These documents also may be available in or through libraries or other informational services.)

## MIL-N-25027/1A

2.3 Order of precedence. In the event of a conflict between the text of this document and the references cited herein (except for related associated detail specifications), the text of this document takes precedence. Nothing in this document, however, supersedes applicable laws and regulations unless a specific exemption has been obtained.

## 3. REQUIREMENTS

3.1 General. Nuts shall be in accordance with the requirements of MIL-N-25027 and as specified herein. Where any conflict exists between MIL-N-25027 and this specification, the latter shall govern.

3.2 Dimensions. Nuts 0.250 through 2.500 inch nominal diameter nuts shall be in accordance with the dimensional requirements of table I. Threads shall be UNJC-3B in accordance with MIL-S-8879.

3.3 Material. Material shall be in accordance with QQ-N-281, class A or B, and have a minimum Rockwell B hardness of 80. Material shall be provided without plating or surface treatments. The nut locking ring or collar material shall be in accordance with ASTM D 4066 Group 1, Class 1 or 2 for continuous operations at temperatures up to 250°F, and MIL-R-46198 Type 1 for continuous operations up to 450°F.

3.4 Axial strength. Nuts shall have a minimum axial strength as specified in table II.

3.5 Identification marking. Nuts shall be marked on the wrenching surface with the manufacturer's identification symbol, material symbol and the lot number. Nuts rated for use at 250 °F shall be marked with material symbol "NICU". Nuts rated for use at 450 °F shall be marked with material symbol "NICUV". Markings shall be permanent in accordance with MIL-STD-792.

## 4. QUALITY ASSURANCE PROVISIONS

4.1 Inspection and quality assurance for special purpose fasteners shall be in accordance with MIL-N-25027, except as specified herein.

4.2 Sampling.

4.2.1 Inspection lot. A lot of nuts shall consist of one heat of material, of one type or style, of the same nominal size, and fabricated in the same batch or by a continuous process under the same conditions as to time and temperature.

4.2.2 Sampling for nondestructive testing, dimensions and markings. Sampling shall be in accordance with Table III. The dimensional characteristics of Table I of this document shall be inspected.

4.2.3 Sampling for chemical analysis. One fastener shall be taken from each lot for testing. Sample may be taken from the heat or finished product.

4.2.4 Sampling for hardness. Sampling shall be in accordance with Table IV.

MIL-N-25027/1A

4.2.5 Sampling for axial tensile strength. Testing shall be in accordance with Table V.

4.3 Examinations and tests.

4.3.1 Thread inspection. Screw thread gauging shall be in accordance with FED-STD-H28 and FED-STD-H28/20, system 21.

4.3.2 Nondestructive testing. Nuts shall be nondestructively inspected by liquid penetrant test in accordance with MIL-STD-271.

4.3.3 Chemical analysis. Chemical analysis shall be in accordance with standard procedures. In case of dispute, chemical analysis shall be in accordance with ASTM E 76. Standard tolerance permitted analysis by QQ-N-281 applies. Certified heat analysis furnished by the material supplier is in lieu of product analysis.

4.3.4 Hardness testing. Nut hardness shall be tested in accordance with ASTM F 606. Hardness in accordance with ASTM A 370 is permitted.

5. PACKAGING

5.1 General. packaging shall be in accordance with ASTM D3951.

6. NOTES

(This section contains information of a general or explanatory nature that may be helpful, but is not mandatory.)

6.1 Intended use. The nuts covered by this specification are intended for use in general shipboard applications including Level 1 piping systems and associated components.

6.2 Acquisition requirements. Acquisition documents must be as specified in MIL-N-25027 and specify the following:

- (a) Title, number, and date of this specification.
- (b) Issue of DoDISS to be cited in the solicitation, and if required, the specific issue of individual documents referenced (see 2.1.1 and 2.2).



MIL-N-25027/1A

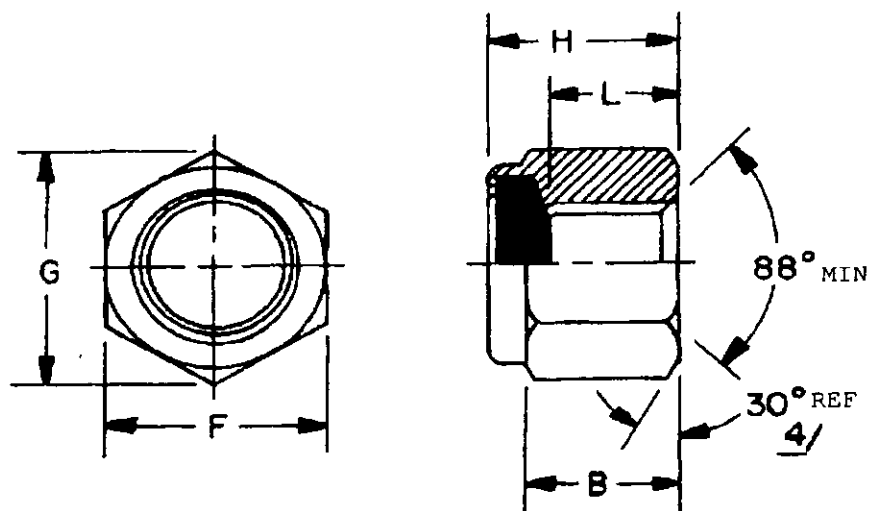

FIGURE 1

## MIL-N-25027/1A

TABLE I. Dimensions of heavy hex, self-locking nuts.

PIN dash no.	Nominal size (in)	Threads per inch	(L) Threaded length (in) REF 1/	(H) Overall nut height (in)		(F) Width across the flats 2/ (in)		(G) Width across corners (in) min 3/	(B) Wrenching flat height (in) REF 4/	Bearing surface sq'ness (in) 5/
				max	min	max	min			
4C	0.250	20	.230	.390	.360	.504	.492	.552	.290	.007
5C	0.312	18	.260	.453	.423	.566	.553	.622	.335	.007
6C	0.375	16	.354	.562	.532	.692	.679	.766	.392	.008
8C	0.500	13	.482	.718	.688	.880	.865	.978	.544	.009
10C	0.625	11	.593	.874	.844	1.068	1.052	1.191	.677	.010
12C	0.750	10	.761	1.015	.985	1.257	1.239	1.403	.790	.010
14C	0.875	9	.872	1.140	1.110	1.446	1.427	1.615	.883	.011
16C	1.000	8	.920	1.312	1.250	1.634	1.614	1.826	1.000	.012
18C	1.125	7	1.038	1.469	1.407	1.822	1.801	2.038	1.096	.013
20C	1.250	7	1.190	1.672	1.610	2.011	1.973	2.232	1.250	.014
22C	1.375	6	1.328	1.828	1.766	2.200	2.159	2.444	1.376	.015
24C	1.500	6	1.376	1.953	1.891	2.388	2.344	2.622	1.413	.016
28C	1.750	5	1.707	2.376	2.250	2.766	2.715	3.075	1.830	.018
32C	2.000	4-1/2	1.816	2.469	2.343	3.142	3.086	3.497	1.750	.020
36C	2.250	4-1/2	2.073	2.876	2.780	3.518	3.457	3.918	2.063	.020
40C	2.500	4	2.381	3.204	3.078	4.020	3.875	4.393	2.475	.020

1/ The tapped hole shall be countersunk on the bearing surface. The maximum countersink diameter shall be equal to the nominal diameter plus 0.030 for 0.375 nominal diameter nuts and smaller, and 1.08 times the nominal diameter for nuts larger than 0.375 nominal diameter. No part of the threaded portion shall project beyond the bearing surface. The measurement of the dimension (L) shall include effective length of the thread engagement, and one countersunk height at the bearing surface. The dimension (L) shall not include the self-locking insert height.

2/ The maximum width across the flats shall not be exceeded. No transverse section through the nut between 25 percent and 75 percent of the height of the wrenching flat measured from the bearing surface shall be less than the minimum width across the flats.

3/ A rounding or lack of fill at the junction of the hex corners with the bearing surface chamfer shall be permissible provided the width across the corners is within specified limits at and beyond a distance equal to 17.5 percent of the nominal diameter from the bearing surface.

4/ The diameter of the bearing surface chamfer circle shall be within the limits of the maximum width across the flats and 95 percent of the minimum width across the flats (see figure 1).

5/ Bearing surface squareness to the nut thread axis shall be measured in accordance with MIL-N-25027.

## MIL-N-25027/1A

TABLE II. Minimum axial strength.

Nominal diameter (in)	Minimum axial strength <u>1/</u> (LB)
0.250	6,000
0.312	8,600
0.375	12,700
0.500	24,800
0.625	38,300
0.750	54,000
0.875	73,000
1.000	95,800
1.125	121,100
1.250	146,600
1.375	186,000
1.500	200,000
1.750	205,000
2.000	233,000
2.250	390,000
2.500	500,000

1/ These values represent ultimate shear failure loads of the nut threads.

TABLE III. Sampling for nondestructive testing, discontinuities, dimensions, and marking.

Lot size	Sample size	ACCEPT	REJECT
2 to 13	all	0	1
14 to 150	13		
151 to 280	20		
281 to 500	29		
501 to 1,200	34		
1,201 to 3,200	42		
3,201 to 10,000	50		
10,001 to 35,000	60		
35,001 to 150,000	74		

TABLE IV. Hardness sampling.

Lot size	Sample size	ACCEPT	REJECT
1 to 25	2	0	1
26 to 50	3		
51 to 90	4		
91 to 150	5		
151 to 280	6		
281 to 500	7		
501 to 1,200	8		
1,201 to 150,000	9		

## MIL-N-25027/1A

TABLE V. Axial Tensile Strength.

Lot size	Sample size	ACCEPT	REJECT
1 to 50	2	0	1
51 to 150	4		
151 to 280	6		
281 to 1,200	8		
Over 1,201	10		