

INCH-POUND

MIL-M-82002D
AMENDMENT 1
14 August 1995

MILITARY SPECIFICATION

MANIFOLD AND ACCESSORY ASSEMBLIES, PORTABLE
FUEL DISTRIBUTION SYSTEMS, QUICK-DISCONNECT HOSE COUPLING TYPE

This amendment forms a part of MIL-M-82002D, dated 03 October 1990, and is approved for use by all Departments and Agencies of the Department of Defense.

PAGE 2

2.1.1, bottom of page: Delete "PPP-T-60 - Tape: Packaging, Waterproof."

PAGE 3

2.1.1, top and middle of page: Delete in its entirety "MIL-P-116, MIL-B-121, MIL-C-16173, MIL-L-21260, MIL-M-28519, MIL-STD-129, and MIL-STD-2073."

2.1.1, middle of page: Delete "MIL-M-28519" and substitute "GGG-M-2742."

2.2, bottom of page: ANSI new address to read "11 West 42nd Street, New York, NY 10036."

PAGE 6

3.7.6, line 1: Delete "MIL-M-28519" and substitute "GGG-M-2742."

PAGES 9 and 10

Section 5, delete paragraph "5.1 thru 5.3" and substitute:

"5.1 Packaging. For acquisition purposes, the packaging requirements shall be as specified in the contract or order (see 6.2). When actual packaging of materiel is to be performed by DoD personnel, these personnel need to contact the responsible packaging activity to ascertain requisite packaging requirements. Packaging requirements are maintained by the Inventory Control Point's packaging activity within the Military Department or Defense Agency, or within the Military Department's System Command. Packaging data retrieval is available from the managing Military Department's or Defense Agency's automated packaging files, CD-ROM products, or by contacting the responsible packaging activity."

AMSC N/A

FSC 3835

DISTRIBUTION STATEMENT A. Approved for public release; distribution is unlimited.

MIL-M-82002D
AMENDMENT 1

6.2, bottom of page: Delete item "g" and substitute:
"g. Packaging requirements (see 5.1)."

Custodian:
Navy - YD1

Preparing Activity:
Navy - YD1

Review Activity:
DLA - CS

(Project 3835-0107)

(INCH-POUND)

MIL-M-82002D
3 October 1990
 SUPERSEDING
 MIL-M-82002C
 21 May 1982

MILITARY SPECIFICATION

MANIFOLD AND ACCESSORY ASSEMBLIES, PORTABLE
 FUEL DISTRIBUTION SYSTEMS, QUICK-DISCONNECT HOSE COUPLING TYPE

This specification is approved for use by all Departments and Agencies of the Department of Defense.

1. SCOPE

1.1 Scope. This specification covers assembled, portable, quick-disconnect, hose coupling type manifold and accessory assemblies with valving, metering, and dispensing features. Type I through type VII are protected with a rollover bar type frame and are of unit construction.

1.2 Classification. Manifold and accessory assemblies are of the following types and styles, as specified (see 6.2), and have male (M) and female (F) quick-disconnect hose connections of the nominal inside diameter, as indicated.

Type I - Seven-way, valved manifold, 6-inch M by six 4-inch F.

Type II - Five-way, valved manifold.

Style A - 6-inch F by four 4-inch F.

Style B - Two 4-inch F by three 4-inch M.

Beneficial comments (recommendations, additions, deletions) and any pertinent data which may be of use in improving this document should be addressed to: Commanding Officer (Code 156), Naval Construction Battalion Center, Port Hueneme, CA 93043-5000, by using the self-addressed Standardization Document Improvement Proposal (DD Form 1426) appearing at the end of this document or by letter.

AMSC N/A

FSC 3835

DISTRIBUTION STATEMENT A. Approved for public release; distribution is unlimited.

MIL-M-82002D

Type III - Wye, three-way, valved manifold.

Style A - 6-inch F by two 6-inch M.

Style B - 6-inch F by two 4-inch M.

Style C - 4-inch F by two 4-inch M.

Style D - 4-inch F by two 3-inch M.

Type IV - Tee, three-way, valved manifold.

Style E - 6-inch F by 6-inch M by 6-inch F.

Style F - 6-inch F by 6-inch M by 4-inch M.

Style G - 6-inch F by 6-inch M by 4-inch F.

Type V - Cross, four-way, valved manifold.

Style H - 6-inch F by three 6-inch M.

Style I - Three 4-inch F by one 4-inch M.

Type VI - Meter and strainer assembly, 6-inch M by 6-inch M.

Type VII - Tee assembly, three-way manifold, frameless, two 6-inch F by one 6-inch M.

Type VIII - Suction stub assembly, frameless, with valve and sight glass flow indicator, 1-inch F by 1-inch M (40-inch suction tube).

Type IX - Adapters.

Style J - Six-inch truck (TRK) flange by female split clamp coupling.

Style K - Six-inch truck (TRK) flange by male split clamp coupling.

2. APPLICABLE DOCUMENTS

2.1 Government documents.

2.1.1 Specifications and standards. The following specifications and standards form a part of this document to the extent specified herein. Unless otherwise specified, the issues of these documents are those listed in the issue of the Department of Defense Index of Specifications and Standards (DODISS) and supplement thereto, cited in the solicitation (see 6.2).

SPECIFICATIONS

FEDERAL

PPP-T-60 - Tape: Packaging, Waterproof.

MIL-M-82002D

MILITARY

- MIL-P-116 - Preservation, Methods of.
- MIL-B-121 - Barrier Material, Greaseproofed, Waterproofed, Flexible.
- MIL-T-704 - Treatment and Painting of Material.
- MIL-C-6183 - Cork and Rubber Composition Sheet; for Aromatic Fuel and Oil Resistant Gaskets.
- MIL-A-8625 - Anodic Coatings, for Aluminum and Aluminum Alloys.
- MIL-V-12126 - Valves, Gate, Bronze, Lever Operated, Quick Opening, 125 PSI and 150 PSI.
- MIL-C-16173 - Thin Film Preservation (Hard Drying, Cold Application).
- MIL-L-21260 - Engine Preservative Oil.
- MIL-C-24356 - Couplings, Segmented, and Split Clamps Reattachable, 2-1/2-, 4-, 6-, and 7-Inch, for Refueling-at-Sea Hose.
- MIL-C-27487 - Coupling Halves, Quick-Disconnect, Cam-Locking Type.
- MIL-S-27661 - Strainer, Sediment, Jet Fuel Unit, 600 GPM.
- MIL-M-28519 - Meter, Volumetric, Positive Displacement, Liquid, Aircraft Fuel, 600 GPM.
- MIL-V-58039 - Valves, Gate, Rising Stem, Double Acting, Aluminum.

STANDARDS

MILITARY

- MIL-STD-129 - Marking for Shipment and Storage.
- MIL-STD-130 - Identification marking of U.S. Military Property.
- MIL-STD-2073 - Parts and Equipment, Procedures for Packaging of.

(Unless otherwise indicated, copies of federal and military specifications, standards, and handbooks are available from Standardization Documents Order Desk, Bldg. 4D, 700 Robbins Avenue, Philadelphia, PA 19111-5094.)

2.2 Non-Government publication. The following document form a part of this document to the extent specified herein. Unless otherwise specified, the issues of the documents which are DOD adopted are those listed in the issue of the DODISS cited in the solicitation. Unless otherwise specified, the issues of documents not listed in the DODISS are the issues of the documents cited in the solicitation (see 6.2).

AMERICAN NATIONAL STANDARDS INSTITUTE, INC. (ANSI)

ANSI B16.5 - Pipe Flanges and Flanged Fittings. (DoD adopted)

(Application for copies should be addressed to the American National Standards Institute, Inc., 1430 Broadway, New York, NY 10018-3308.)

MIL-M-82002D

(Non-Government standards and other publications are normally available from the organizations that prepare or distribute the documents. These documents also may be available in or through libraries or other informational services.)

2.3 Order of precedence. In the event of a conflict between the text of this document and the references cited herein, the text of this document takes precedence. Nothing in this document, however, supersedes applicable laws and regulations unless a specific exemption has been obtained.

3. REQUIREMENTS

3.1 Description. Manifold and accessory assemblies consist of flanges, coupling halves, valves, gaskets, meter and strainer, and rollover frames as specified herein in various arrangements and combinations.

TABLE I. Type, style, and figure number.

Type	Configuration	Figure Number
I	Seven-way valved manifold, 6-inch M by six 4-inch F	1
II	Five-way valved manifold	
	Style A - 6-inch F by four 4-inch F	2
	Style B - Two 4-inch F by three 4-inch M	2
III	Wye, three-way valved manifold	3
	Style A - 6-inch F by two 6-inch M	3
	Style B - 6-inch F by two 4-inch M	3
	Style C - 4-inch F by two 4-inch M	3
	Style D - 4-inch F by two 3-inch M	3
IV	Tee, three-way valved manifold	
	Style E - 6-inch F by 6-inch M by 6-inch F	4
	Style F - 6-inch F by 6-inch M by 4-inch M	5
	Style G - 6-inch F by 6-inch M by 4-inch F	4
V	Cross, four-way valved manifold	
	Style H - 6-inch F by three 6-inch M	6
	Style I - 3-inch F by one 4-inch M	7
VI	Meter and strainer assembly, 6-inch M by 6-inch M	8
VII	Tee assembly three-way manifold, frameless, two 6-inch F by one 6-inch M	9
VIII	Suction stub assembly, frameless, with valve and sight glass 1-inch F by 1-inch M (40-inch suction tube)	10
IX	Adapters	12
	Style J - 6-inch TRK flange by F split clamp coupling	
	Style K - 6-inch TRK flange by M split clamp coupling	

MIL-M-82002D

3.2 First article. When specified in the contract or purchase order (see 6.2), a sample shall be subjected to first article inspection (see 4.2.1 and 6.3).

3.3 Figures. Figures 1 through 12 form a part of this specification and are engineering design sketches only. The supplier is responsible for preparing his own shop drawings. Where tolerances prescribed could cumulatively result in incorrect fits, the supplier shall provide tolerances within those prescribed on the sketches to insure correct fit, assembly, and operation of items.

3.4 Materials. Material shall be as specified herein and as specified on the applicable figures. Materials used shall be free from defects which would adversely affect the performance or maintainability of individual components or of the overall assembly. Materials not specified herein shall be of the same quality used for the intended purpose in commercial practice. Unless otherwise specified herein, all equipment, material, and articles incorporated in the work covered by this specification are to be new and fabricated using materials produced from recovered materials to the maximum extent possible without jeopardizing the intended use. The term "recovered materials" means materials which have been collected or recovered from solid waste and reprocessed to a source of raw materials, as opposed to virgin raw materials. Unless otherwise specified, none of the above shall be interpreted to mean that the use of used or rebuilt products are allowed under this specification.

3.5 Interchangeability. All assemblies of the same classification furnished with similar options under a specific contract shall be identical to the extent necessary to insure interchangeability of component parts, assemblies, accessories, and spare parts.

3.6 Performance. Assemblies shall be capable of operating with a working pressure of not less than 125 pounds per square inch gage (psig) when the largest hose connection is not more than 4 inches and shall withstand a hydrostatic pressure of not less than 300 psig. When 6-inch hose connections are provided, the assemblies shall withstand a hydrostatic test pressure of 150 psig. Frames surrounding assemblies shall protect the valves in the fully opened and closed positions, and to all other components during conditions of rollover (see 4.5.1).

3.7 Design and construction. The assemblies shall be designed and constructed of aluminum in accordance with the applicable figure and as specified herein. The general arrangement of the individual assemblies shall be in accordance with the specified type and style (see 1.2), and the applicable figure as indicated in table I. Figure dimensions are approximate, and may be reduced provided valves and couplings are protected from possible damage during rollover and clearance is provided for valve operation, service, and hose disconnect levers.

3.7.1 Dissimilar metals. Direct contact between dissimilar metals which have the potential of producing galvanic corrosion shall be avoided. When such contact is unavoidable, an interposing insulating material shall be provided to minimize the corrosive effect.

MIL-M-82002D

3.7.2 Rollover frames. Frames shall be designed in accordance with table I and applicable figure. Adjoining surfaces of the pipe framework and mounting plates shall be welded continuously to provide maximum strength. Frames shall be so designed to provide protection, for the assemblies mounted within, against any rollover condition. Where complete protection is not provided by the pipe framework, mitered corners may be used.

3.7.3 Flanges. The flanges of valves, fittings, and coupling halves shall be truck type, aluminum, 125-150 pound class, and integral with or welded as one piece to the main body. Except for the meter and strainer assembly, flange dimensions (nominal) shall be in accordance with table II. Flange dimensions for the meter and strainer assembly, and appended coupling halves shall be in accordance with ANSI B16.5, class 150.

TABLE II. Truck flange dimensions.

Nominal Pipe size	Outside diameter (inches)	Bolt circle (inches)	Number of bolts	Bolt hole size (inches)	Bolt size (inches)
3	5-5/8	4-7/8	8	7/16	3/8
4	6-5/8	5-7/8	8	7/16	3/8
6	9	8-1/8	12	7/16	3/8
Tolerance: $\pm 1/64$ -inch					

3.7.4 Coupling halves.

3.7.4.1 Quick-disconnect. Coupling halves of the cam-locking quick-disconnect type shall conform to MIL-C-27487, class 1, type and size as applicable, except the suction stub coupling (figure 10) shall be type V.

3.7.4.2 Split clamp. Coupling halves of the split-clamp type shall conform to MIL-C-24356, figure 1, and shall be furnished with one split clamp and band assembly per figure 3 of MIL-C-24356.

3.7.5 Valves. Valves shall be double-acting rising stem gate valves conforming to MIL-V-58039, type I, except that the suction stub valve shall conform to MIL-V-12126, class 1.

3.7.6 Meter. The meter for the type VI assembly shall conform to MIL-M-28519.

MIL-M-82002D

3.7.7 Strainer. The strainer for the type VI assembly shall be provided with nominal 6-inch flanged inlet and outlet connections to match the mating parts and otherwise conform to MIL-S-27661.

3.7.8 Gaskets. Gaskets shall be provided at all bolted connections and shall conform to MIL-C-6183, type II, class 1, grade B, having a minimum thickness of 1/16-inch.

3.7.9 Hardware. All screws shall have a hex-cap type head and length required for the intended use. Nuts shall be hex-cap type with a washer surface. Split lockwashers shall be used on all bolted connections.

3.8 Unit marking. Assemblies shall be marked for identification in accordance with the contractor's standard marking procedures for like equipment. When specified (see 6.2), the assemblies shall be marked in accordance with MIL-STD-130.

3.9 Finish. Unless otherwise specified, after the completion of all welding and prior to final assembly, all exterior aluminum framing surfaces shall be anodic coated in accordance with MIL-A-8625, type as applicable, dyed to an approximate olive drab color. When specified (see 6.2), completed assemblies shall be painted in accordance with MIL-T-704, type A, olive drab color.

3.10 Workmanship.

3.10.1 Aluminum fabrication. The fabrication process shall not cause kinks, sharp bends, or other conditions to be imparted to the aluminum parts which could be detrimental to the finished product's ability to meet the specified requirements. All bends shall be made by controlled means to insure uniformity of size and shape.

3.10.2 Bolted connections. Boltholes shall be accurately punched or drilled and shall have the burrs removed. Washers or lockwashers shall be provided in accordance with good commercial practice, and all bolts, nuts, and screws shall be tight.

3.10.3 Welding. Welding procedures shall be in accordance with a nationally recognized welding code. The surface of parts to be welded shall be free from rust, scale, paint, grease, or other foreign matter. Welds shall be of sufficient size and shape to develop the full strength of the parts connected by the welds. Welds shall transmit stress without permanent deformation or failure when the parts connected by the weld are subjected to proof and service loadings.

3.10.4 Castings. All castings shall be sound and free from patching, misplaced coring, warping, or any other defect which reduces the ability of the casting to perform its intended function.

MIL-M-82002D

4. QUALITY ASSURANCE PROVISIONS

4.1 Responsibility for inspection. Unless otherwise specified in the contract or purchase order, the contractor is responsible for the performance of all inspection requirements (examinations and tests) as specified herein. Except as otherwise specified in the contract or purchase order, the contractor may use his own or any other facilities suitable for the performance of the inspection requirements specified herein, unless disapproved by the Government. The Government reserves the right to perform any of the inspections set forth in this specification where such inspections are deemed necessary to ensure supplies and services conform to prescribed requirements.

4.1.1 Responsibility for compliance. All items shall meet all requirements of sections 3 and 5. The inspection set forth in this specification shall become a part of the contractor's overall inspection system or quality program. The absence of any inspection requirements in the specification shall not relieve the contractor of the responsibility of ensuring that all products or supplies submitted to the Government for acceptance comply with all requirements of the contract. Sampling inspection, as part of manufacturing operations, is an acceptable practice to ascertain conformance to requirements, however, this does not authorize submission of known defective material, either indicated or actual, nor does it commit the Government to accept defective material.

4.2 Classification of inspections. The inspection requirements specified herein are classified as follows:

- a. First article inspection (see 4.2.1).
- b. Quality conformance inspection (see 4.2.2).

4.2.1 First article inspection. The first article inspection shall be performed on one assembly when a first article is required (see 3.2 and 6.2). This inspection shall include the examination of 4.3 and the tests of 4.4. The first article may be either a first production item or a standard production item from the supplier's current inventory provided the item meets the requirements of the specification and is representative of the design, construction, and manufacturing technique applicable to the remaining items to be furnished under the contract.

4.2.2 Quality conformance inspection. The quality conformance inspection shall be performed on each item and shall consist of the examination of 4.3, the test of 4.4, and the packaging inspection of 4.5.

4.3 Examination. Each assembly shall be examined for compliance with the requirements specified in section 3 of this specification. Any redesign or modification of the contractor's standard product to comply with specified requirements, or any necessary redesign or modification following failure to meet specified requirements shall receive particular attention for adequacy and suitability. This element of inspection shall encompass all visual examinations and dimensional measurements. Noncompliance with any specified requirements or presence of one or more defects preventing or lessening maximum efficiency shall constitute cause for rejection.

MIL-M-82002D

4.4 Tests. The first article shall receive the tests of 4.4.1 and 4.4.2. Each production unit shall receive the test of 4.4.2. Failure to pass any test shall constitute cause for rejection.

4.4.1 Rollover test. Prior to hydrostatic testing, assemblies mounted in frames shall be placed on a flat paved surface, with the valves closed. A resilient mat, not over 1/4-inch thick, may be placed on the surface to protect the finish of the frames. Each of the assemblies shall be rolled by hand over each of the twelve edges and allowed to drop flat not less than three times on each of the six faces. This test shall be repeated with the valves fully open. Any visual evidence of cracks, distortion, bent frames, loose connections, separation of welds, or damage to valves, meters, or strainer shall be cause for rejection.

4.4.2 Hydrostatic test. Each assembly shall be capped or plugged and subjected to the test pressure as specified in 3.6 for not less than one minute. While the assembly is under pressure, all valves shall be opened and closed. Any evidence of distortion, leakage at gaskets, valves, connections, or seams shall be cause for rejection.

4.5 Packaging inspection. The preservation, packing, and marking of the item shall be inspected to verify conformance to the requirements of section 5.

5. PACKAGING

5.1 Preservation. Preservation shall be level A or commercial as specified (see 6.2).

5.1.1 Level A.

5.1.1.1 Methods of preservation. Cleaning processes, drying procedures, preservatives, and methods of preservation specified in the following paragraphs are listed in MIL-P-116 and shall conform to the requirements of MIL-P-116 and any applicable specifications.

5.1.1.2 Cleaning and drying. Prior to the application of preservative compounds or paint, surfaces shall be cleaned by process C-1 and dried by any applicable procedure of MIL-P-116.

5.1.1.3 Unpainted surfaces. Unpainted exterior surfaces, including threaded surfaces, shall be coated with type P-1 preservative in accordance with MIL-C-16173 grade 1.

5.1.1.4 Valves, strainers and assemblies. Interior surfaces of valves, strainers, and assemblies shall be coated with type P-10 preservative in accordance with MIL-L-21260, type 1, grade 10, 30 or 50. Openings into the valves, meters, and strainers shall be covered with barrier material conforming to MIL-B-121, class C and held in place with waterproof tape in accordance with PPP-T-60.

5.1.2 Commercial. The equipment shall be preserved in accordance with the contractor's standard practice in a manner to prevent deterioration and damage.

MIL-M-82002D

5.2 Packing. Packing shall be level A, B, or commercial as specified (see 6.2).

5.2.1 Levels A and B. Packing shall be in accordance with MIL-STD-2073 for the applicable level specified. Each manifold assembly shall be individually packed in containers selected from table VII of MIL-STD-2073 for the appropriate level of protection. Open crates shall not be used for level A packing.

5.2.2 Commercial. The equipment shall be prepared for shipment in a manner which will insure arrival at destination in a satisfactory condition. Preparation for delivery shall comply with applicable carrier rules and regulations.

5.3 Marking. Marking shall be in accordance with MIL-STD-129.

6. NOTES

(This section contains information of a general or explanatory nature that may be helpful, but is not mandatory.)

6.1 Intended use. Portable quick-disconnect fuel distribution manifold and accessory assemblies are intended for use in the interconnection of fuel storage tanks, fuel supply, and dispensing hose lines at tank farms. The assemblies facilitate quick installation of any fuel distribution system where quick-disconnect type hose connections are used.

6.2 Acquisition requirements. Acquisition documents should specify the following:

- a. Title, number, and date of the specification.
- b. Type and style required (see 1.2).
- c. When specifications and standards are other than as specified (see 2.1.1 and 2.2).
- d. When a first article is required (see 3.2, 4.2.1, and 6.3).
- e. When unit marking in accordance with MIL-STD-130 is required in lieu of commercial marking (see 3.8).
- f. When assemblies shall be painted in accordance with MIL-T-704, type A in lieu of anodic coating (see 3.9).
- g. Level of preservation and level of packing required (see 5.1 and 5.2).

6.3 First article. When a first article is required, it shall be tested and approved under the appropriate provisions of paragraph 7-104.55 of the Defense Acquisition Regulations. The first article should be a first production item consisting of one complete assembly or it may be a standard production item from the contractor's current inventory as specified in 4.2.1. The contracting officer should include specific instructions in acquisition documents regarding arrangements for examination, test and approval of the first article.

MIL-M-82002D

6.4 Subject term (key word) listing.

High speed dispensing system
Tank farm dispenser

6.5 Changes from previous issue. Marginal notations are not used in this revision to identify changes with respect to the previous issue due to the extensiveness of the changes.

Custodian:
Navy - YD

Preparing activity:
Navy - YD

User activities:
Army - ME, CE

(Project No. 3835-N095)

MIL-M-82002D

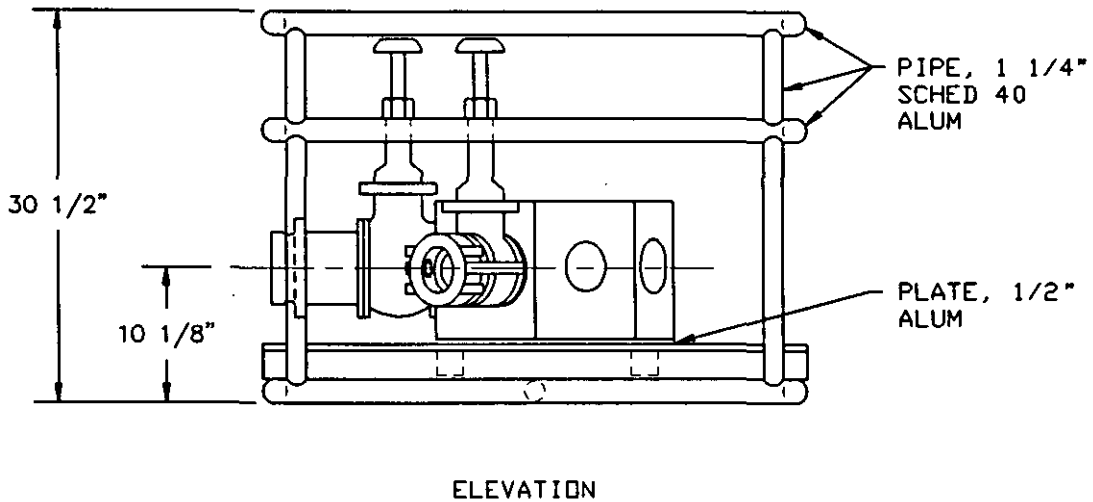
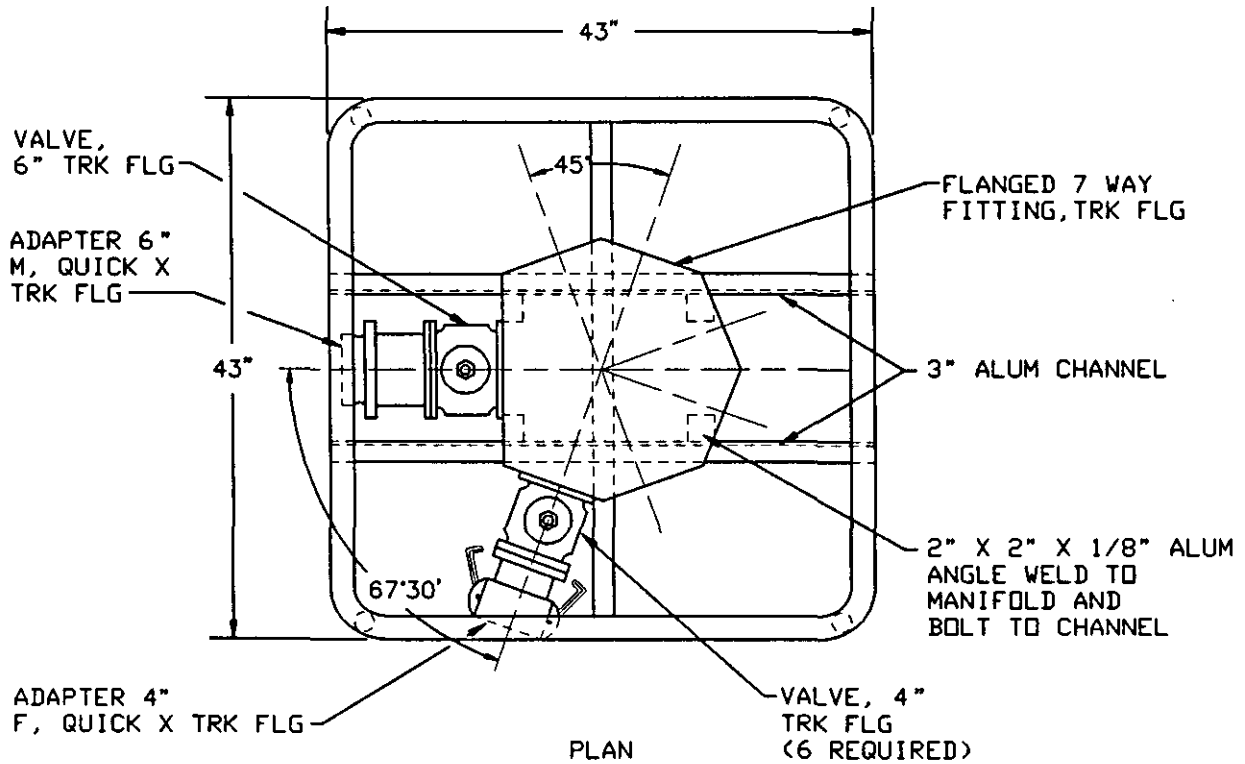

NOTE:

1. BOLTS, STUDS, NUTS AND GASKETS AS REQUIRED.

FIGURE 1. Type I - Seven-way valved manifold.

MIL-M-82002D

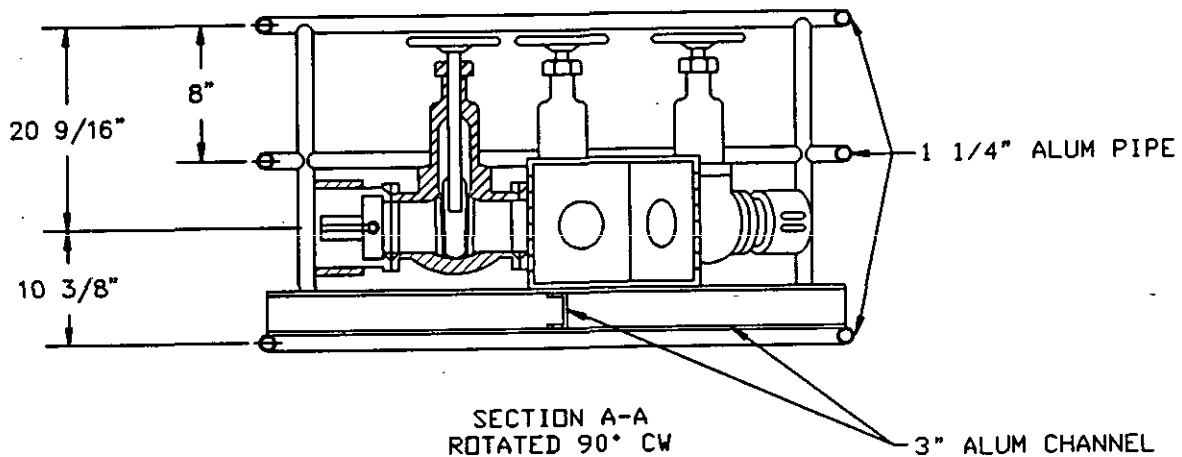
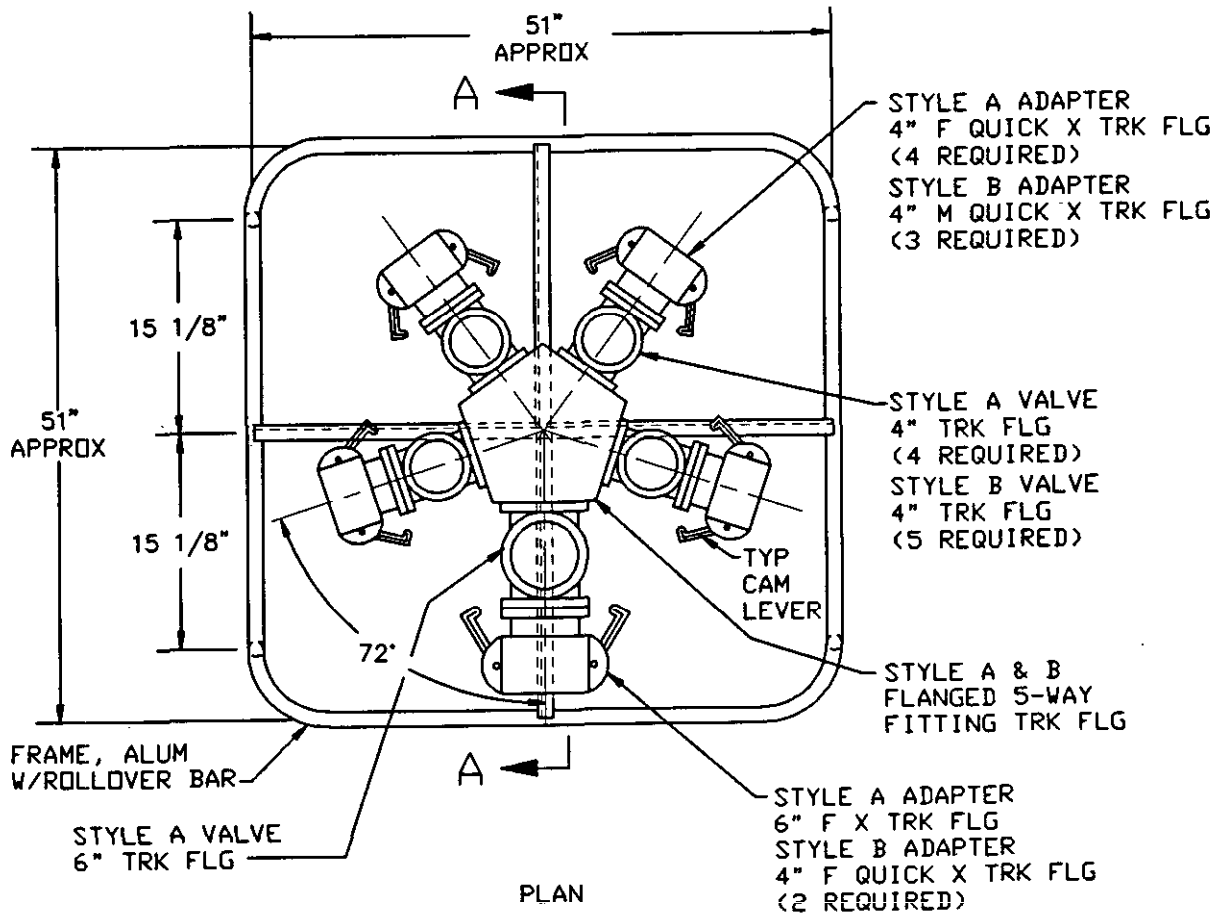

NOTE:

1. BOLTS, STUDS, NUTS AND GASKETS AS REQUIRED.

FIGURE 2. Type II - Five-valved manifold, styles A and B.

MIL-M-82002D

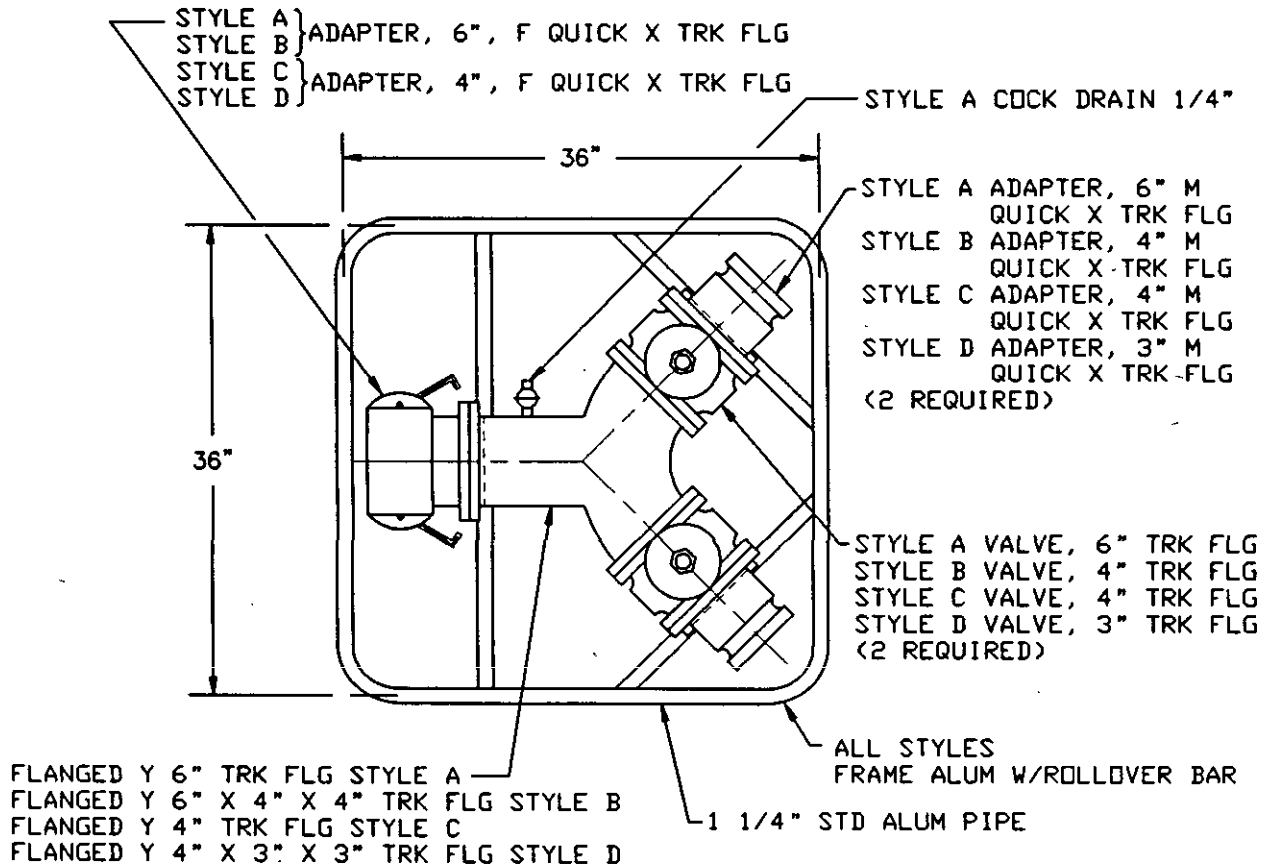

PLAN

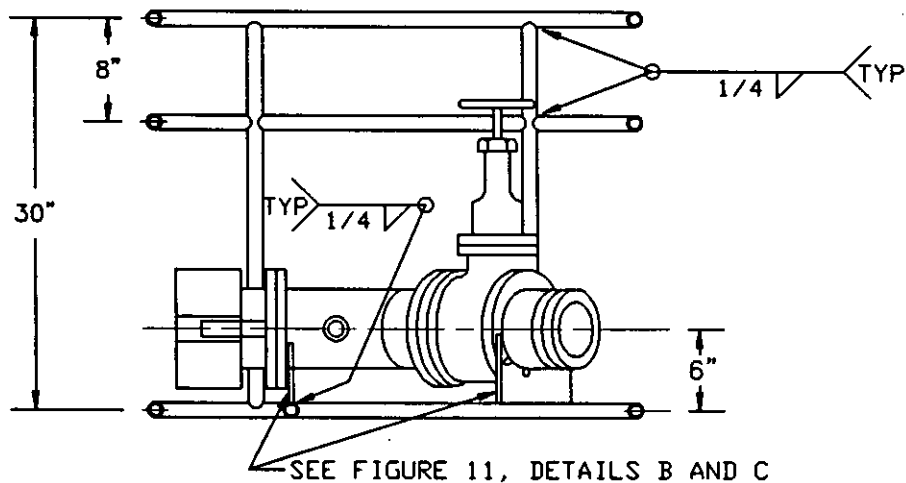

ELEVATION

NOTE:

1. BOLTS, NUTS AND GASKETS AS REQUIRED.

FIGURE 3. Type III - Wye three-way valved manifold styles A, B, C, and D.

MIL-M-82002D

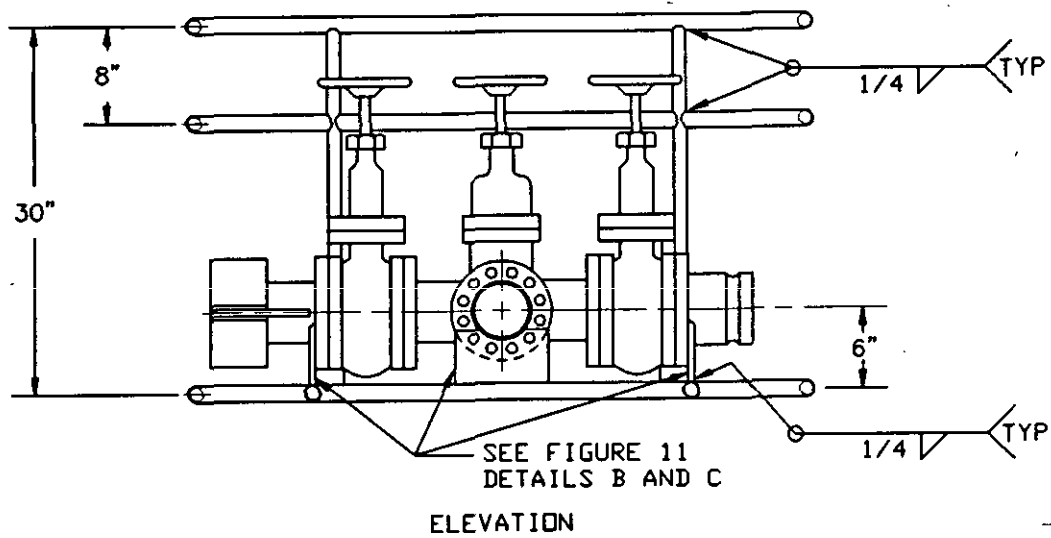
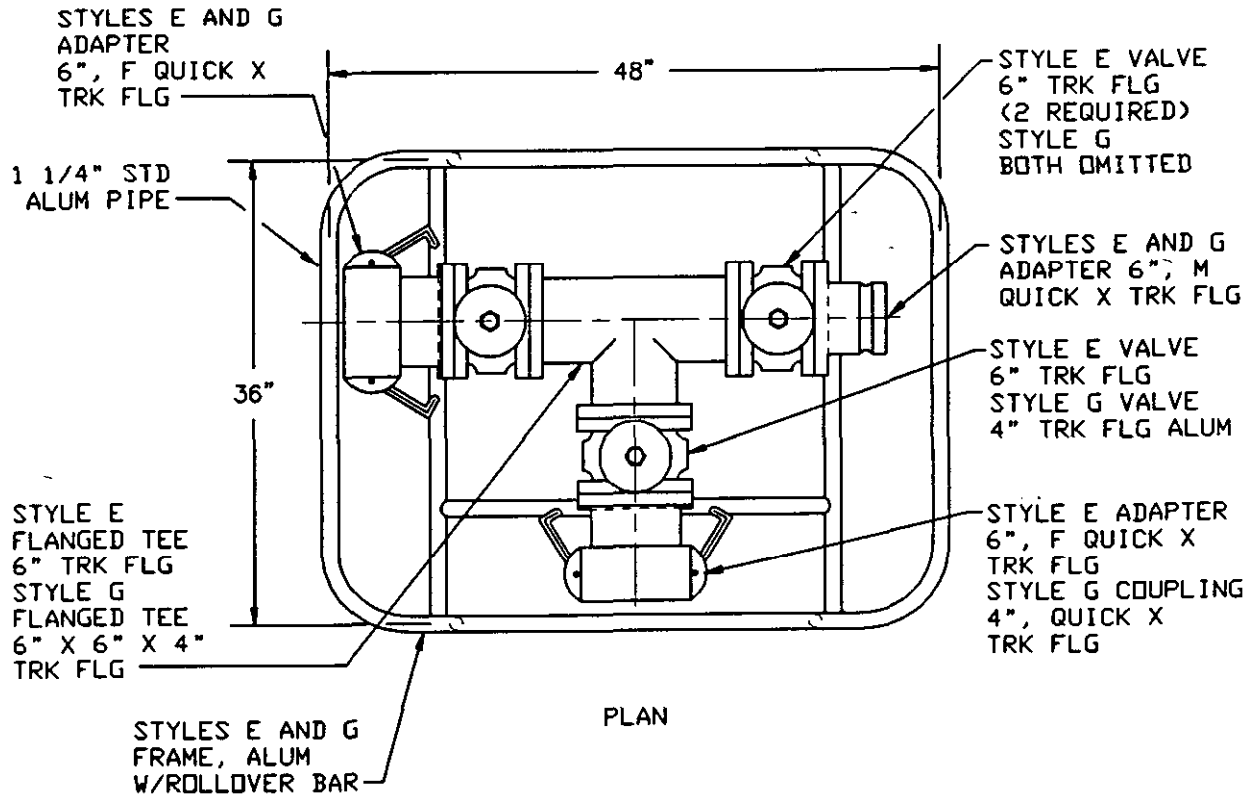

NOTE:

1. BOLTS, STUDS, NUTS AND GASKETS AS REQUIRED.

FIGURE 4. Type IV - Tee three-way valved manifold, styles E and G.

MIL-M-82002D

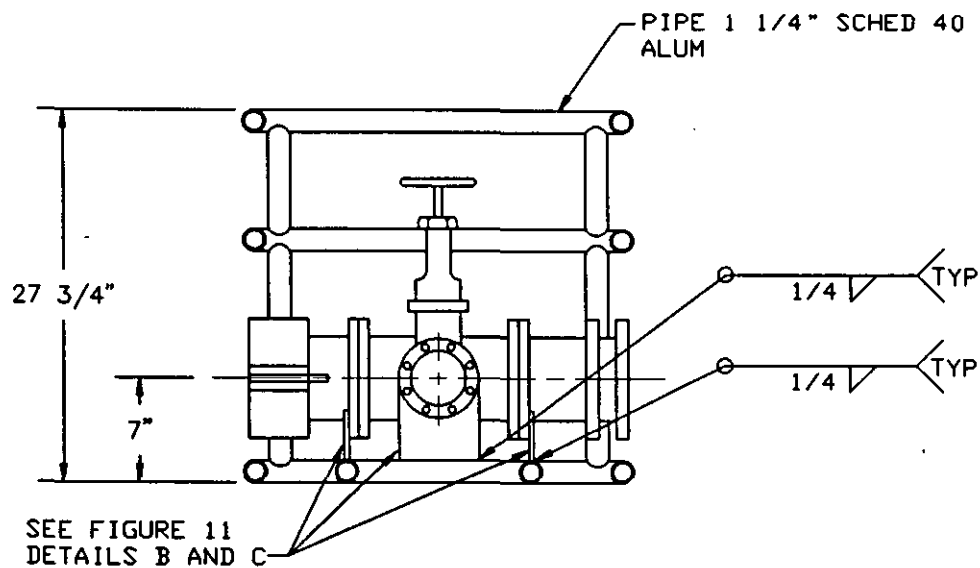
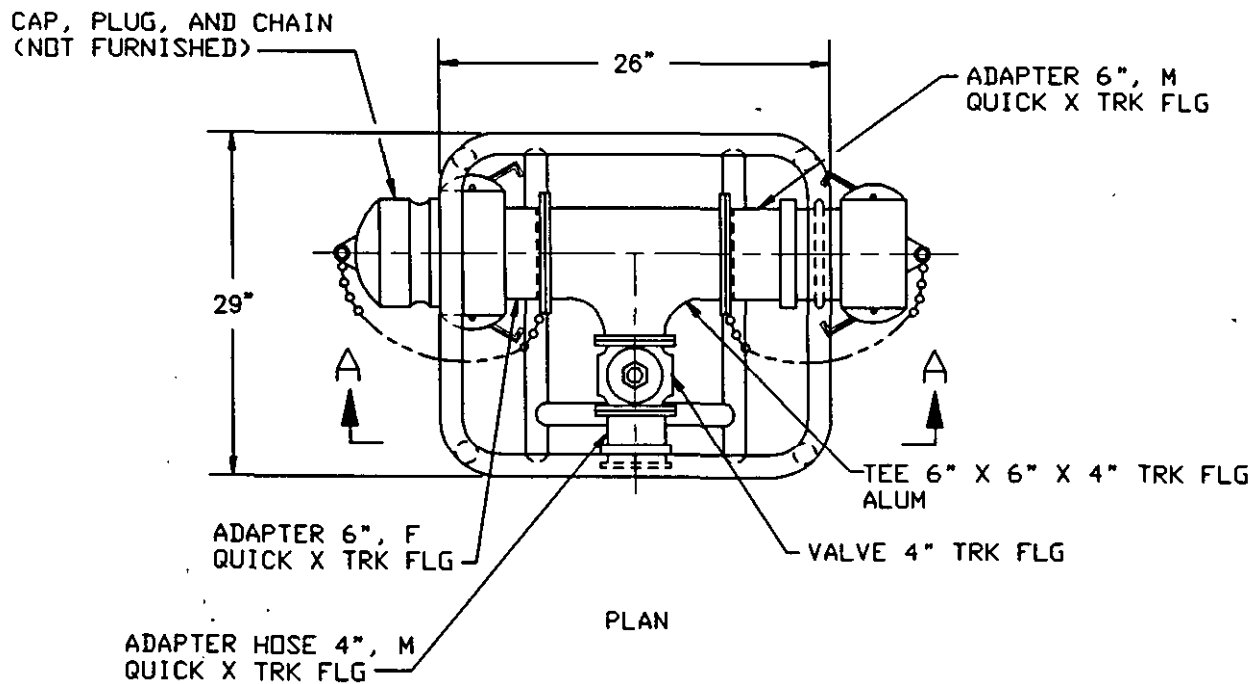

SECTION A-A

NOTE:

1. BOLTS, NUTS AND GASKETS AS REQUIRED.

FIGURE 5. Type IV - Tee three-way valved manifold, style F.

MIL-M-82002D

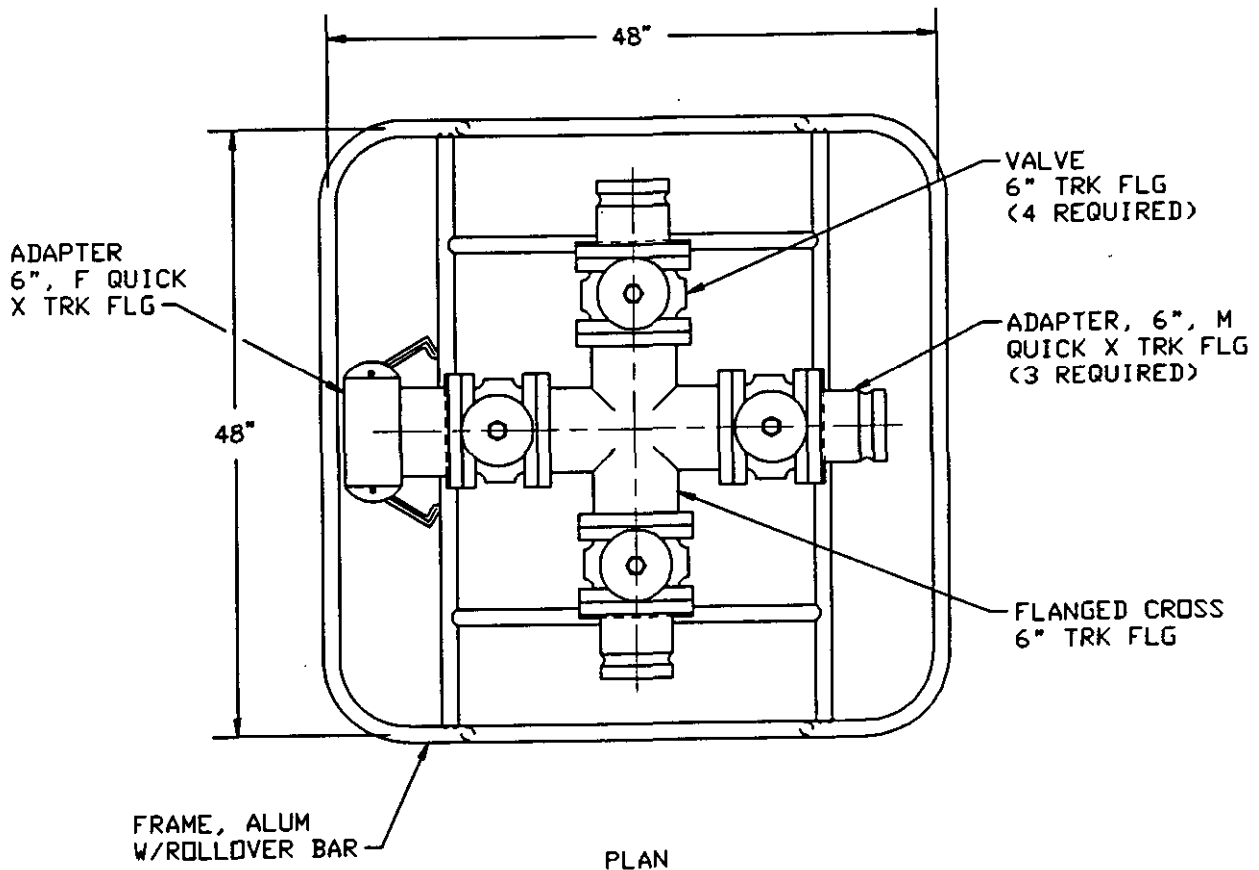

PLAN

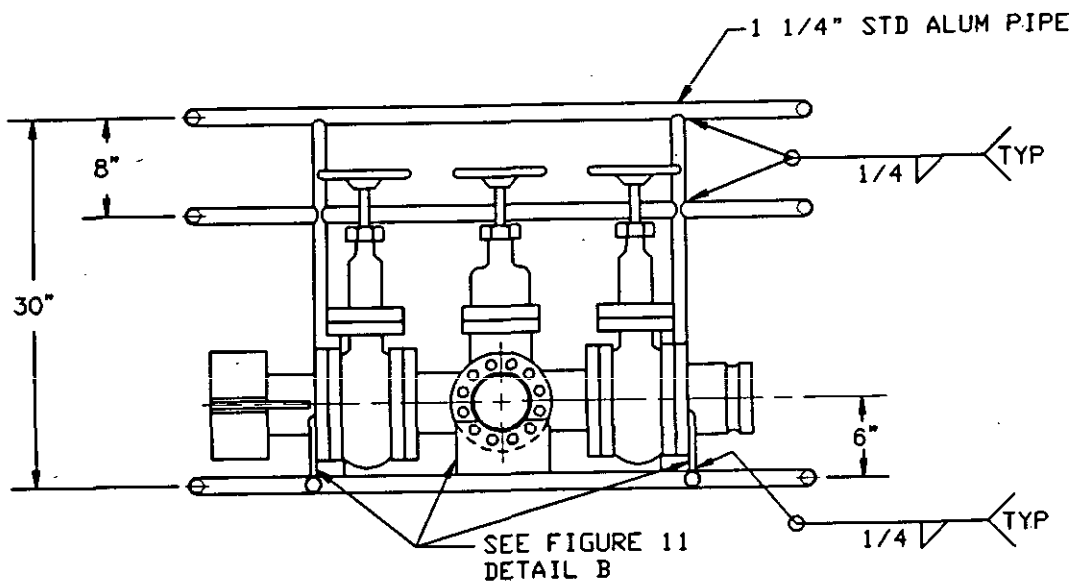

ELEVATION

NOTE:

1. BOLTS, NUTS AND GASKETS AS REQUIRED.

FIGURE 6. Type V - Cross four-way valved manifold, style H.

MIL-M-82002D

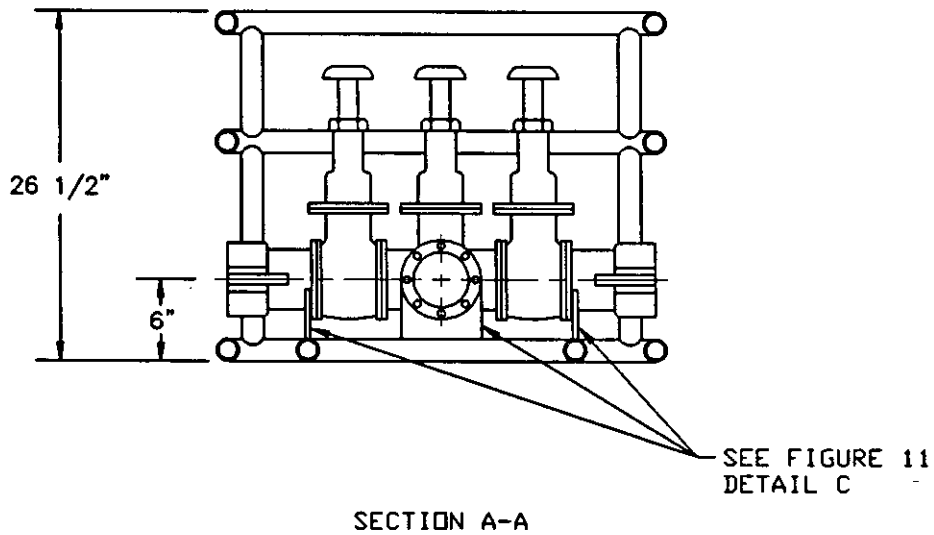
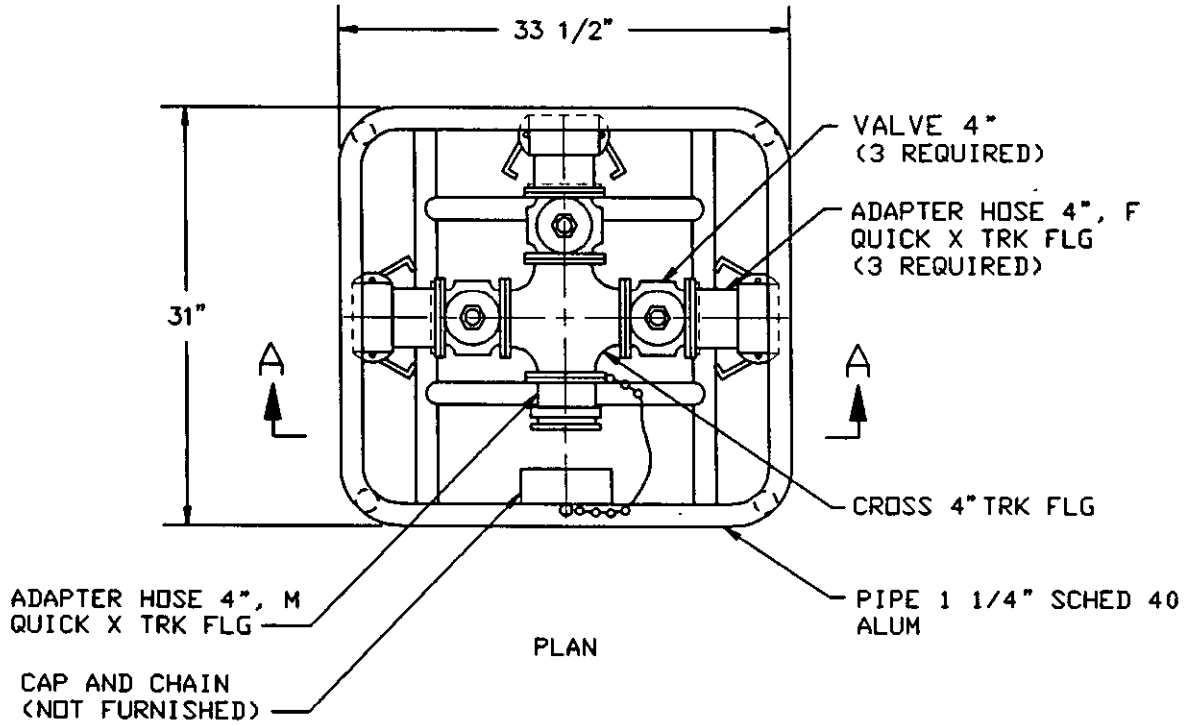

NOTE:

1. BOLTS, NUTS AND GASKETS AS REQUIRED.

FIGURE 7. Type V - Cross four-way valved manifold, style 1.

MIL-M-82002D

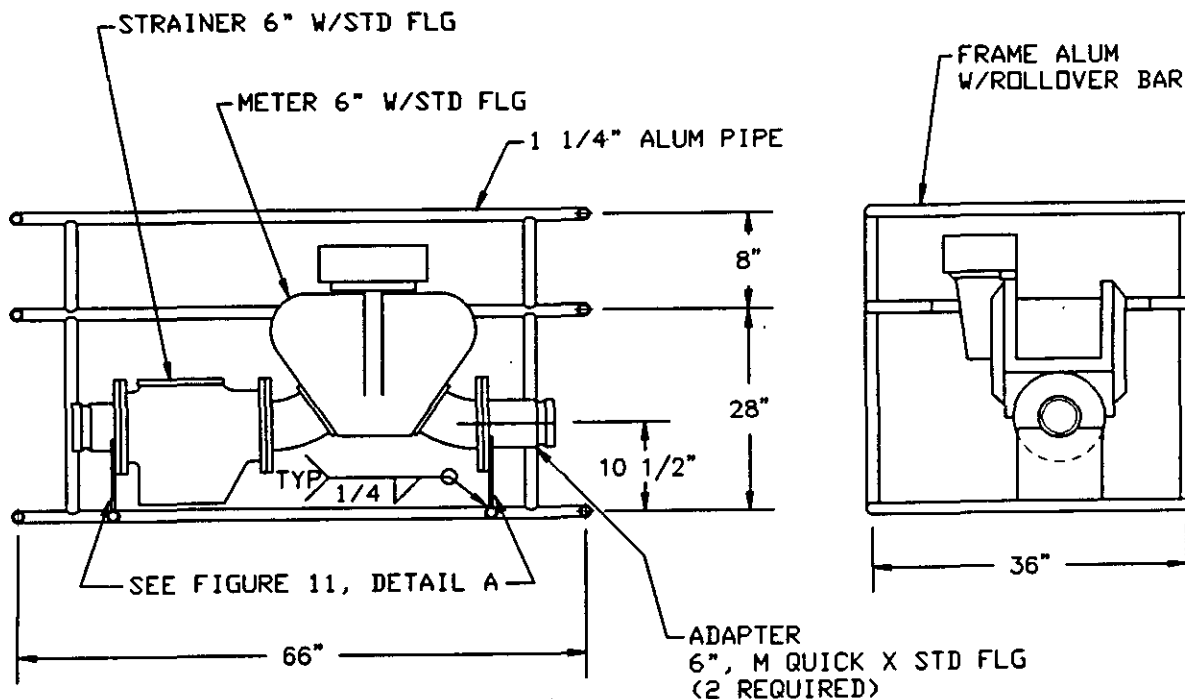

NOTE:

1. BOLTS, NUTS AND GASKETS AS REQUIRED.

METER 6N 600 GPM

FIGURE 8. Type VI - Meter and strainer assembly.

MIL-M-82002D

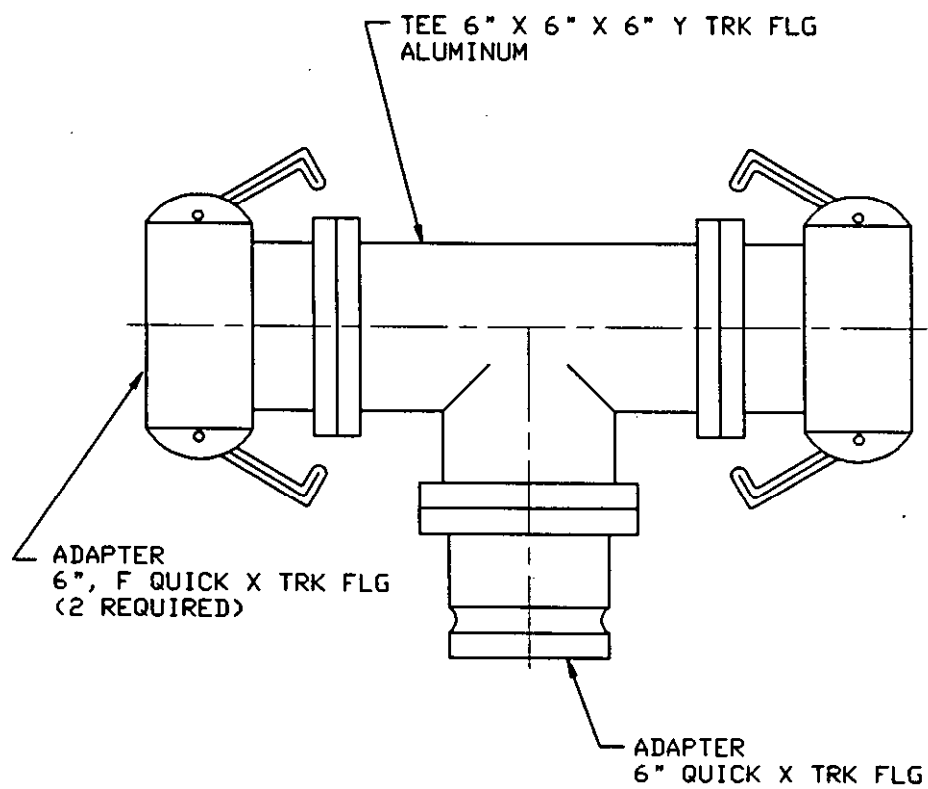

NOTE:

1. BOLTS, NUTS AND GASKETS AS REQUIRED.

FIGURE 9. Type VII - Tee assembly, frameless, three-way manifold.

MIL-M-82002D

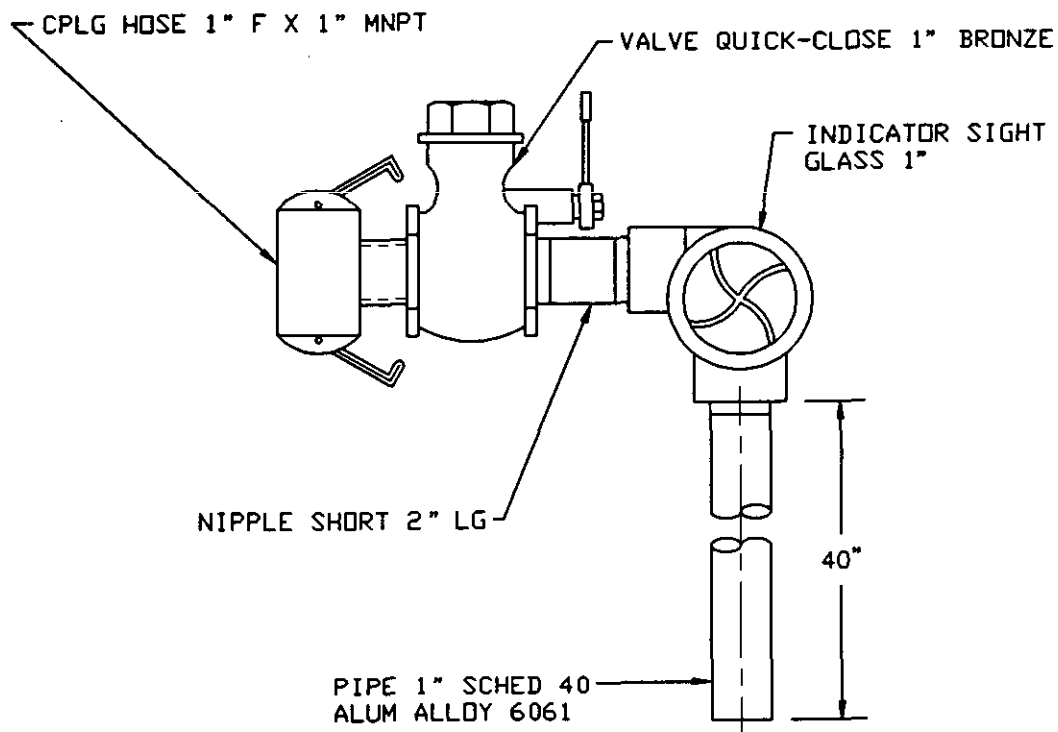

NOTE:

1. BOLTS, NUTS AND GASKETS AS REQUIRED.

FIGURE 10. Type VIII - Suction stub assembly, frameless.

MIL-M-82002D

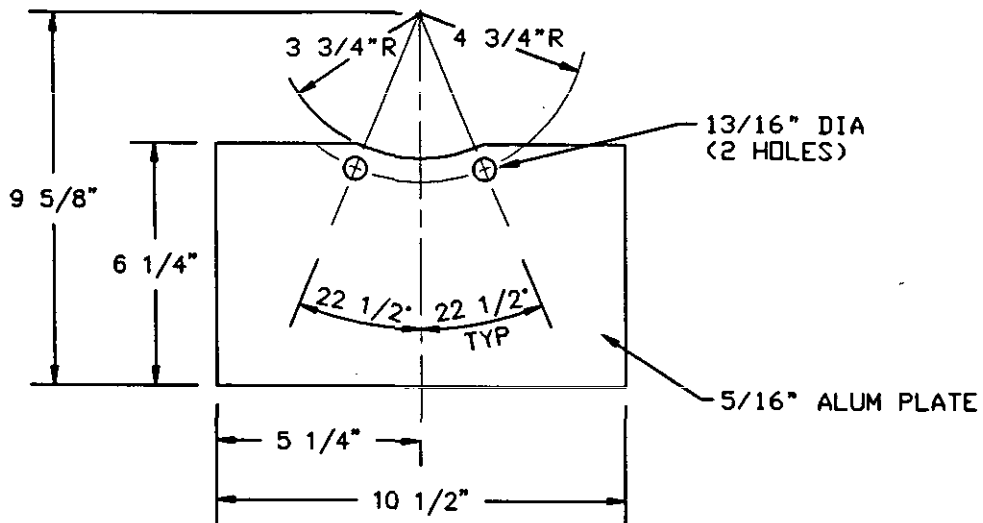

DETAIL A

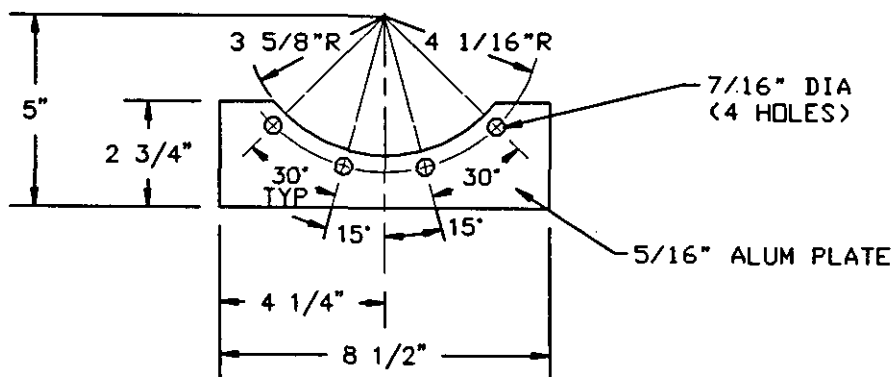

DETAIL B

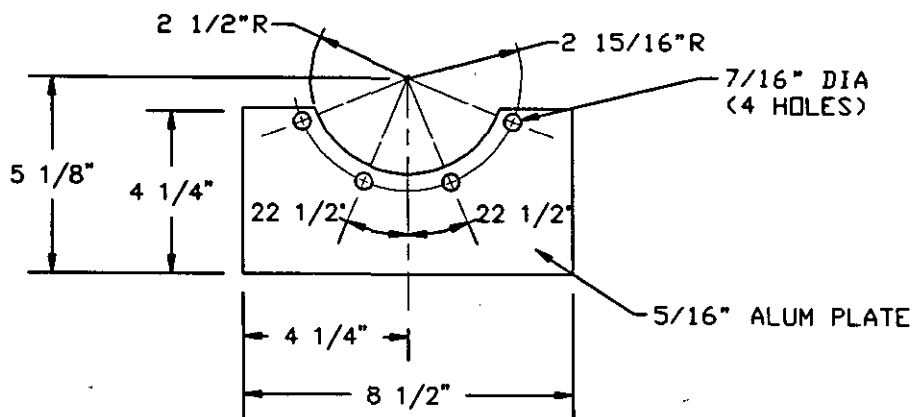

DETAIL C

FIGURE 11. Support details.

MIL-M-82002D

FOR DETAILS
OF FEMALE END
AND SIZE REQ'D
SEE FIGURE 1
MIL-C-24356

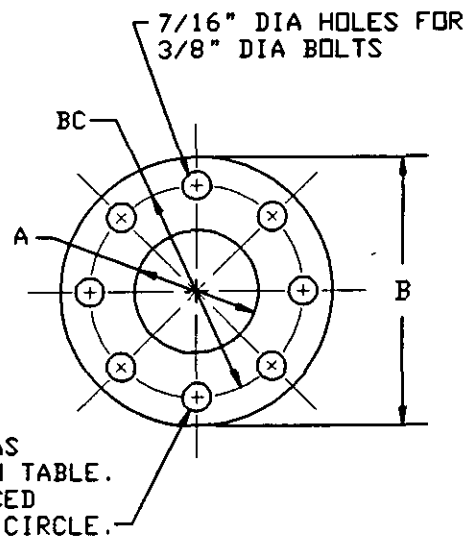
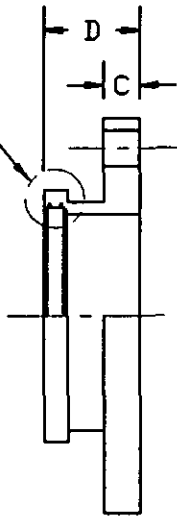

BOLT HOLES AS
SPECIFIED IN TABLE.
EQUALLY SPACED
AROUND BOLT CIRCLE.

STYLE - J

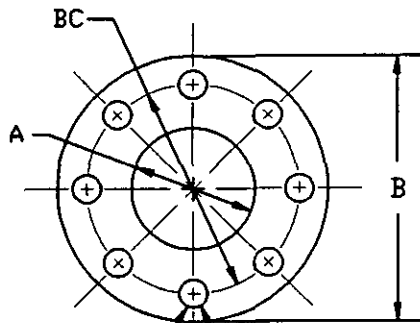

BOLT HOLES AS
SPECIFIED IN TABLE.
EQUALLY SPECIFIED
AROUND BOLT CIRCLE.

7/16" DIA HOLES FOR
3/8" DIA BOLTS

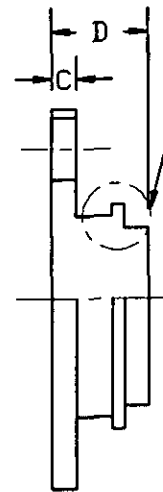

FOR DETAILS
OF MALE END
AND SIZE REQ'D
SEE FIGURE 1
MIL-C-24356

HOSE SIZE	A NOM	B NOM	B C	C	D	BOLT HOLES
6	6	8 7/8	8 1/8	3/8	6 MIN 7 MAX	12
4	4	6 5/8	3 7/8	3/8	4 MIN 5 MAX	8

NOTES:

1. DIMENSIONS=IN INCHES NOMINAL, UNLESS OTHERWISE SPECIFIED.
2. TOLERANCES=FRACTIONS $\pm 1/64$.

STYLE - K

FIGURE 12. Type IX - Adapter-flange x split clamp coupling, styles J and K.

STANDARDIZATION DOCUMENT IMPROVEMENT PROPOSAL

INSTRUCTIONS

1. The preparing activity must complete blocks 1, 2, 3, and 8. In block 1, both the document number and revision letter should be given.
2. The submitter of this form must complete blocks 4, 5, 6, and 7.
3. The preparing activity must provide a reply within 30 days from receipt of the form.

NOTE: This form may not be used to request copies of documents, nor to request waivers, or clarification of requirements on current contracts. Comments submitted on this form do not constitute or imply authorization to waive any portion of the referenced document(s) or to amend contractual requirements.

1. RECOMMEND A CHANGE:		1. DOCUMENT NUMBER MIL-M-82002D	2. DOCUMENT DATE (YYMMDD) 1990 October 3
3. DOCUMENT TITLE MANIFORD AND ACCESSORY ASSEMBLIES, PORTABLE FUEL DISTRIBUTION SYSTEMS, QUICK-DISCONNECT HOSE COUPLING TYPE			
4. NATURE OF CHANGE (Identify paragraph number and include proposed rewrite, if possible. Attach extra sheets as needed.)			
5. REASON FOR RECOMMENDATION			
6. SUBMITTER			
a. NAME (Last, First, Middle Initial)		b. ORGANIZATION	
c. ADDRESS (Include Zip Code)		d. TELEPHONE (Include Area Code) (1) Commercial (2) AUTOVON (If applicable)	7. DATE SUBMITTED (YYMMDD)
8. PREPARING ACTIVITY			
a. NAME R. E. PAMPLONA, Project Manager Equipment Criteria Development Division		b. TELEPHONE (Include Area Code) (1) Commercial (805) 982-5843	(2) AUTOVON 551-5843
c. ADDRESS (Include Zip Code) Commanding Officer (156) Naval Construction Battalion Center Port Hueneme, CA 93043-5000		IF YOU DO NOT RECEIVE A REPLY WITHIN 45 DAYS, CONTACT: Defense Quality and Standardization Office 5203 Leesburg Pike, Suite 1403, Falls Church, VA 22041-3466 Telephone (703) 756-2340 AUTOVON 289-2340	