

MIL-M-25047C (ASG)**18 JUNE 1968**

Superseding

~~MIL-M-25047B (ASG)~~

28 September 1964

MILITARY SPECIFICATION**MARKINGS AND EXTERIOR FINISH COLORS
FOR AIRPLANES, AIRPLANE PARTS, AND MISSILES
(BALLISTIC MISSILES EXCLUDED)**

This specification has been approved by the Department of the Air Force and by the Naval Air Systems Command.

1. SCOPE

1.1 This specification covers the markings used in identification of aircraft and missiles, major structural assemblies, fuselage, plumbing, wiring controls, parts, etc.

1.1.1 Also listed herein are the standard colors to be used on the exterior * surface of Air Force aircraft (see 3.5).

2. APPLICABLE DOCUMENTS

2.1 The following documents, of the issue in effect on date of invitation for bids or request for proposal, form a part of this specification to the extent specified herein:

*** SPECIFICATIONS****Federal**

L-P-387 Plastic Sheet, Laminated, Thermosetting (for Designation Plates)

Military

MIL-D-1000 Drawings, Engineering and Associated Lists
 MIL-W-5088 Wiring, Aircraft, Installation of
 MIL-I-6140 Insignia, National Aircraft
 MIL-F-7179 Finishes and Coatings, General Specification for
 Protection of Aircraft and Aircraft Parts
 MIL-P-7962 Primer Coating, Cellulose-Nitrate Modified Alkyd
 Type, Corrosion-Inhibiting, Fast-Drying (for
 Spray Application Over Pretreatment Coating)
 MIL-W-8160 Wiring, Guided Missile, Installation of, General
 Specification for
 MIL-I-8500 Interchangeability and Replaceability of Component
 Parts for Aircraft and Missiles

FSC 1500

MIL-M-25047C(ASG)

MIL-C-8514	Coating Compound, Metal-Pretreatment, Resin-Acid
MIL-D-8634	Decal, Elastomeric Pigmented Film, for Use on Exterior Surfaces
MIL-D-8635	Decals, for Use on Interior Surfaces
MIL-P-8651	Plates: Identification and Modification (for Aircraft) Installation of
MIL-F-18264	Finishes, Organic, Weapon System, Application and Control of
MIL-I-18464	Insignia and Markings for Naval Weapons Systems
MIL-L-19537	Lacquer, Acrylic-Nitrocellulose, Gloss (for Aircraft Use)
MIL-L-19538	Lacquer; Acrylic-Nitrocellulose, Camouflage (for Aircraft Use)
MIL-P-19834	Plates, Identification, Metal Foil, Adhesive Backed
MIL-P-21563	Paint System, Fluorescent, for Aircraft Application
MIL-P-21600	Paint System, Fluorescent, Removable, for Aircraft Application
MIL-A-25165	Aircraft Emergency Escape System, Identification of
MIL-P-38477	Plastic Material, Pressure Sensitive, for Aircraft Identification and Marking

STANDARDS**Federal**

FED. STD. NO. 595 Colors

Military

MIL-STD-130	Identification Marking of US Military Property
MIL-STD-143	Specifications and Standards, Order of Precedence for the Selection of
MIL-STD-1247	Identification of Pipe, Hose and Tube Lines for Aircraft, Missile, and Space Systems
MS29525	Cap, Pressure Fuel Servicing, 2-1/2 Inch Flush Type
MS33645	Receptacle Installation, Fuel Nozzle Jumper, Aircraft to Servicing Hose
MS33739	Aircraft Markings, Servicing and Precautioning
MS90327	Aircraft Markings, Access Numbering System

PUBLICATIONS**Department of the Air Force Directive**

Arctic Marking

MIL-M-25047C(ASG)

(Copies of specifications, standards, drawings, and publications required by suppliers in connection with specific procurement functions should be obtained from the procuring activity or as directed by the contracting officer.)

3. REQUIREMENTS

3.1 Detail requirements. - Information detailed in specifications and drawings referenced herein shall be applicable as detail requirements of this specification. Where the requirements of the listed specifications and this specification conflict, the requirements of this specification shall govern.

3.1.1 Deviations. - Any deviation from this specification for aircraft and missile markings shall be subject to approval by the procuring activity.

3.2 Material. -

3.2.1 Selection of specifications and standards. - Specifications and standards for necessary commodities and services not specified herein shall be selected in accordance with MIL-STD-143.

* 3.2.2 Material quality. - The marking material (dope, lacquer, or enamel) shall be of the same material if possible, or of a material compatible with that used for the finish on the surface to be marked. Unless otherwise specified by the procuring activity, requirements for marking materials and application of nameplates, including those of dissimilar metals, shall conform to requirements for finishes and coatings for protection of aircraft and aircraft parts as specified in MIL-F-7179. When a coated material for surface finishes is not available or is not practicable, a suitable paste color may be mixed with a suitable clear material.

3.2.3 Application limitations. - Paint or other markings shall not be applied to aircraft or missiles when such application interferes with launching, operation, thermal reactance, light reflection, aerodynamics, or preservation.

3.2.3.1 Metal-marking instruments. - Sharp-pointed metal-marking instruments shall not be used in the layout of insignia and other markings on aircraft and missiles.

3.2.3.2 Static balance - preservation and maintenance. - Paint or marking, when applied to propellers, rotors, or statically balanced control surfaces for antiglare or protective purposes, shall be applied only by the manufacturer or an authorized facility. Between overhauls, when required, marking and finishes may be retained by a light maintenance touchup. Touchup shall be applied to all surfaces in proportionate amounts for retention of proper balance.

3.3 General marking requirements. - Each part and assembly, except the following, shall be permanently and legibly marked with the same number as the manufacturer's part number in accordance with MIL-STD-130 or as otherwise specified (see 3.3.4):

MIL-M-25047C(ASG)

- (a) Parts or assemblies that do not have a suitable nor sufficient surface for a part number.
- (b) Parts or assemblies that are permanently assembled by welding, brazing, soldering, or riveting. These parts or assemblies shall carry their assembly part number.

3.3.1 Marking drawings.- When required, marking drawings shall conform to
* MIL-D-1000.

3.3.1.1 Drawings.- Unless otherwise specified, the contractor shall submit three view drawings of the aircraft or missile to the Government representative designated by the procuring activity for approval. The drawings shall be suitably dimensioned, showing size, where applicable, and location of external insignia and standard identification markings, precautionary and warning markings, and service point markings prescribed by the specification.

3.3.2 Parts interchangeability.- Requirements for physical interchangeability and replaceability of parts shall conform to MIL-I-8500.

3.3.3 Wire installations.- Aircraft wire number assignments for installation of wiring and wiring devices used for interconnection of electric and electronic equipment shall conform to MIL-W-5088 for aircraft use or MIL-W-8160 for missiles.

3.3.4 Identification plates.-

3.3.4.1 Permanent nameplate.- Aircraft shall be identifiable by a nameplate plainly visible in the cockpit and permanently installed in accordance with MIL-P-8651.

3.3.4.2 Equipment and accessory identification plates.- Unless otherwise specified by the procuring activity, identification and information plates for aircraft equipment and accessories shall conform to MIL-P-8651. Plastic materials approved for designation plates, including charts and instruction plates, shall conform to L-P-387. Metallic-foil adhesive-backed plates shall conform to MIL-P-19834.

3.3.4.3 Structural assembly, identification plates.- Identification and modification plates for aircraft structural assemblies shall conform to MIL-P-8651 and shall provide space for recording modification changes.

3.3.4.3.1 Frame marking.- Components of each airfoil and frame shall be permanently and legibly marked with its part number, assigned in accordance with
* MIL-D-1000.

* 3.3.5 Access panel identification.- Interior and exterior aircraft panels, plates, and access doors which require opening or removal at the time of inspection or overhaul shall be identified by the access numbering system in accordance with MS90327.

MIL-M-25047C(ASG)

- 3.4 Style or lettering. - Vertical block type letters and Arabic numerals of uniform size and shape shall be used for all markings. The width of the letters shall be approximately two-thirds of the height; the width of the individual strokes forming them, the letter "I", and normal spacing between letters shall be one-sixth the height. Colors shall be as specified in 3.5. Unless otherwise specified, all letters shall be 1 inch in height, except where, due to space limitations, they may be reduced to 1/2 inch.
- * 3.5 Color and gloss of marking material. - For Air Force, color and gloss of marking and finish materials shall be as follows:

Fed. Std. No. 595
Color No.

Application

Gloss:

Aluminized	17178	Standard exterior finish for Air Force use
White	17875	Insignia and markings required on red background; solar and thermal resistant finishes
Black	17038	May be used as a substitute for Insignia Blue No. 15044; markings over insignia red and yellow warning or precautionary marking; exterior finish for night missions when authorized
Blue	15045	For authorized trim, e.g., separation stripe between solar and conventional finishes
Blue	15044	Insignia and markings
Red	11136	Insignia and markings
Yellow	13538	Warning and precautionary markings; escape hatch, window, door, and emergency exit entry markings
Orange	12197	Powerplant disassembly markings

Lusterless:

White	37875	Insignia and markings for camouflaged aircraft
Red	31136	
Blue	35044	
Light green	34187	
Orange-yellow	33438	For use on rotor blades
		Warning and precautionary markings; escape hatch, window, door and emergency entry markings for camouflaged aircraft
Gray	36622	Bottom finishes for camouflaged aircraft
Tan	30219	For variegated pattern finishes on the upper surfaces of camouflaged aircraft
Green	34079	
Green	34102	
Green	34159	
Green	34201	

MIL-M-25047C(ASG)

Gray	36473	For forward air controller aircraft bottom finishes
Black	37038	Antiglare

* 3.5.1 Finish.- Unless otherwise specified to meet camouflage or antiglare requirements, aircraft and missile finishes and markings shall be glossy. The standard finishing materials for Air Force use shall be an acrylic nitrocellulose system consisting of wash primer in accordance with MIL-C-8514, primer coating in accordance with MIL-P-7962, and top coated in accordance with MIL-L-19537 for conventional finishes or MIL-L-19538 for camouflaged. Other materials approved by the procuring activity may be used, when required, to meet temperature, environmental, or compatibility conditions.

* 3.6 Decalcomanias.- Decalcomanias may be used for all insignia and markings required by this specification on aircraft and missiles. When decals are used they shall conform to the following criteria. For interior application, where not affected by wind and elements, use decalcomanias in accordance with MIL-D-8635, type 5. For exterior application on low performance aircraft not subject to extreme speed and altitude, use decals in accordance with MIL-D-8634. For exterior application on high performance aircraft subject to extremes of temperature, speed and altitude, use decals in accordance with MIL-P-38477. MIL-P-38477 decals may be furnished with perforation holes upon request; however, decals with perforation holes may be applied only over the complete paint system. Application of decals shall in no way be deleterious to the surface to which applied. Decals shall not be applied over brazier head rivets.

3.6.1 Decalcomania sizes (for Air Force).- (For Navy, see (MIL-I-18464.)

3.6.1.1 National insignia decalcomanias.- National insignia decalcomanias shall be available in blue circle diameters (excluding border) of not less than 10 nor more than 60 inches; the 10- to 35-inch diameters shall be in 5-inch increments and the 40- to 60-inch diameters shall be in 10-inch increments.

3.6.1.2 Decalcomania letter heights.- Decalcomania letter heights shall be as follows:

Small:	1, 2, 3, 4-1/2, and 6 inches high
Medium:	9, 12, 15, 18, and 21 inches high
Large:	24, 30, 42, and 48 inches high
Letter sizes larger than 48 inches high:	12-inch increment

Dimensions for letters 2 inches in height or less shall be compatible to the nearest 1/16-inch fractional dimension to retain basic 1/3 ratios for height, width and stroke, e.g., for letters 1 inch in height, 15/16 inch would be a commensurate dimension for letter width 5/8 inch and stroke 3/16 inch.

MIL-M-25047C(ASG)

3.7 External finish identification.- Paint coatings applied to the external surfaces of aircraft and missiles, such as the wing (or section thereof, if painted in sections), the fuselage, and fixed and movable control surfaces, the main landing gear, and the engine cowling shall be identified in accordance with MIL-F-18264. Letters shall be not less than 1/2 inch in height (for optimum letter size, see 3.9.2.4.1).

* 3.7.1 Record of finish application.- Complete information concerning the coating used, identified by the applicable military specification; the preparation of the area to be coated; and the touch-up or replacement procedure for the material used shall be included in the applicable aircraft structural repair instructions.

NOTE: For paint materials not included in a military specification, identification of material and name of manufacturer shall be listed. Markings shall not be applied over thermally reflective coatings.

3.7.2 Fabric exterior finishes.- All fabric-covered aircraft and control surfaces at the time of manufacture or following major fabric repairs involving replacement shall be identified by markings with letters having a minimum height of 1/2 inch applied to the trailing edge. The marking, in abbreviated form, shall indicate the manufacturer or overhaul activity, the material and number of coatings applied, and the date of application as a matter of service life record. Subsequent refinish coatings shall be recorded in the same manner supplemental to the original markings.

3.7.3 Miscellaneous standard markings.- Miscellaneous and special markings shall be as follows.



3.7.3.1 Color and style of markings.- Unless otherwise specified, Arabic numerals and capital letters shall be used for markings. The color of markings shall be black or white, whichever provides the greater contrast with the surrounding surface. The material (dope, lacquer, or enamel) used for the markings shall be the same as that used to finish the surface to be marked. If the surface is bare, enamel is recommended. If the paint material used for the surface finish is not available, or if its use is not practicable, any substitute suitable for letter marking may be used (see 3.7.1).

3.7.3.2 Propeller, rotor, and turbine safety markings.- To avoid an unbalanced condition, safety marking applications to statically balanced propellers and rotor blades shall be limited to new blades or to overhauled blades, processed only by recognized contractors or authorized overhaul agencies (see 3.2.3.2).

3.7.3.2.1 Lusterless colors.- Lusterless colors only shall be used for propellers and rotor blade identification danger zone marking, or preservation and antiglare purposes, unless otherwise noted herein. Before lacquer is applied, all surfaces shall be thoroughly cleaned and primed in accordance with 3.5.1.

MIL-M-25047C(ASG)

* 3.7.3.2.2 Blades.- For Air Force, blades less than 15 feet in diameter will have 4-inch yellow tips. Blades larger than 15 feet will have a 6-inch yellow tip. Lusterless lacquer in accordance with MIL-L-19538, color No. 33538 will be used for this application. For Navy, blades shall be painted as shown on figure 1. Propeller blades on multi-engined planes shall be painted on both sides from the tip to 3 inches from the tip with insignia white Fed. Std. color No. 17875, followed by a 6-inch strip of insignia red Fed. Std. color No. 11136, followed by another 3-inch strip of insignia white. The remainder of the blade shall be colored black, Fed. Std. color No. 37038, except this may be eliminated on blades where both the following conditions are met: (1) corrosion protection is not required and (2) the blades are so situated as to produce no glare or excessive brightness in the pilot's or copilot's eyes; e.g., in cases where the blades rotate in a plane aft of the pilot's seat. If the blades are so situated as to produce glare or excessive brightness in the pilot's or copilot's eyes, the insignia red and insignia white shall be replaced by bright red and insignia white, Fed. Std. color Nos. 31136 and 37875, respectively, on the rear face of the blades only. Propeller blades on single-engine planes shall be painted on the front side in the same manner as for multi-engine blades; the rear face, however, shall be colored black, Fed. Std. color No. 37038, with a 4-inch band of orange-yellow, Fed. Std. color No. 33538, at the tip for blades of less than 15 feet basic diameter and a 6-inch orange-yellow band for larger diameter blades.

3.7.3.2.2.1 Fuselage propeller warning stripe and signs.- That area of the fuselage which is in the plane of the propeller path shall be marked with an insignia red stripe, Fed. Std. color No. 11136, 3 inches wide extending completely around the fuselage, as shown on figure 2. The word "PROPELLER" reading vertically from top to bottom, on both sides, shall be superimposed on this stripe in insignia white letters, Fed. Std. color No. 17875, 2 inches in height, at sufficiently frequent intervals to indicate the dangerous area. The signs "DANGER  " and "  DANGER " shall be applied perpendicular to and centered with respect to the word "PROPELLER", one sign on each side thereof, with the arrow pointing toward the stripe. The letters and arrows shall be insignia red and shall be superimposed on a stripe of white, 3 inches in width. The height of the letters and length of the arrows shall be 2 inches.

3.7.3.2.2.2 Bomb bay, hatch, etc., exit warning stripe and signs.- On all planes where bomb bays, hatches, or other openings exist within 6 feet of each side of the propeller disk, and which may be used as a means of egress from the plane and there is danger of personnel walking into propellers after leaving such opening, warning stripes and signs shall be placed, as follows, to definitely warn personnel regarding the proximity of propellers:

Those interior areas of the fuselage, bomb bay flaps, etc., which are in the plane of the propeller disk, shall be marked with insignia red stripes, 3 inches wide, extending on both sides from center of fuselage to the lowest extremity of such exit, when open. The word "PROPELLER" reading vertically from

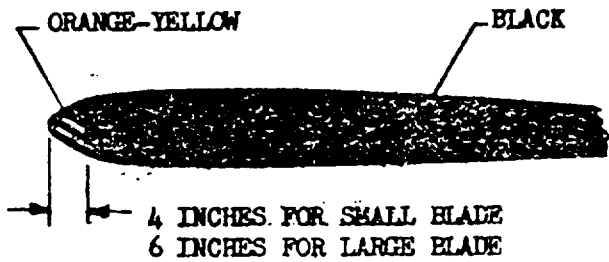

REAR VIEW

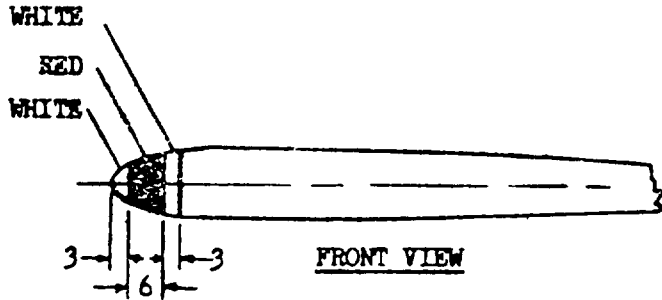

FRONT VIEW

PROPELLER BLADE SINGLE ENGINE

- WHITE
- FED. STD. COLOR NO. 17875 OR
- FED. STD. COLOR NO. 37875
- RED
- FED. STD. COLOR NO. 31136 OR 11136
- BLACK
- FED. STD. COLOR NO. 37038
- ORANGE YELLOW
- FED. STD. COLOR NO. 13538

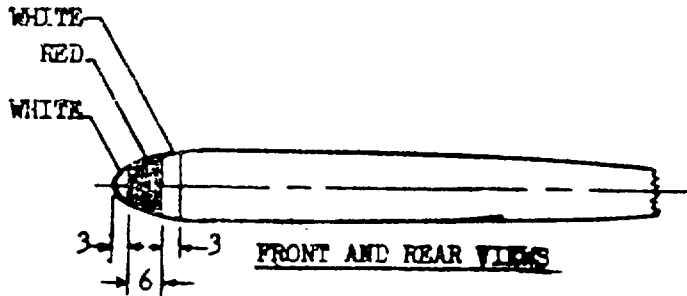

FRONT AND REAR VIEWS

PROPELLER BLADE MULTI-ENGINE

FIGURE 1. (Navy) Color scheme for reciprocating single and multi-engine airplane propellers

MIL-M-250478(ASG)

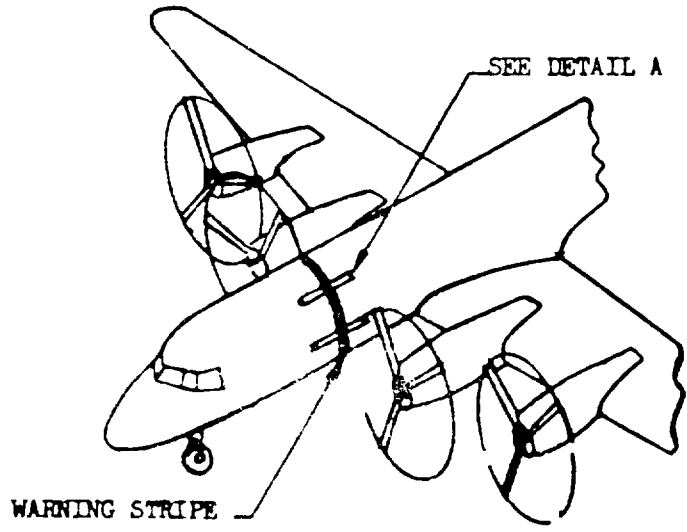
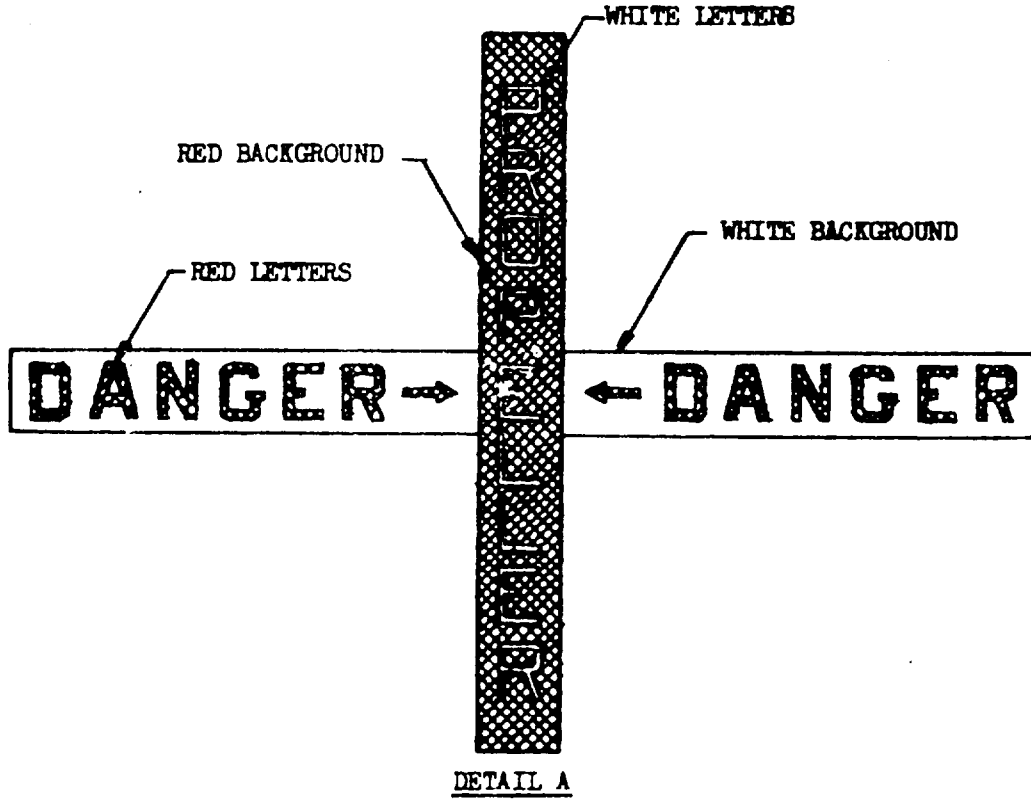

FIGURE 2. Example of multi-engine aircraft showing location of propeller warning stripe and signs on fuselage in plane of propeller

MIL-M-25047C(ASG)

top to bottom on both sides, shall be superimposed on this stripe in insignia white letters, 2 inches in height, at sufficiently frequent intervals to indicate the dangerous areas.

The signs: "DANGER
PROPELLER"  " and "  " DANGER
PROPELLER"

shall be applied perpendicular to and centered with respect to the word "PROPELLER", one sign on each side thereof, with the arrow pointing toward the stripe. The letters and arrows shall be insignia red, and shall be superimposed on a stripe of white, 3 inches in width. The height of the letters and length of the arrows shall be 2 inches.

3.7.3.2.2.3 On aircraft having engines staggered in the wing, a marking similar to that described in 3.7.3.2.2.1 shall also be placed on the cowling of the next inboard engine to mark the plane of rotation of the propeller disk.

3.7.3.2.3 Main rotor blade markings.- Main rotor blade markings shall be as follows. (Also see recessed fittings (3.7.6.1.1).)

3.7.3.2.3.1 Classification numbers.- Classification numbers shall be stenciled on the main rotor blades of all helicopters by any facility authorized to balance or alter the blade. These numbers shall consist of 3 parts. The first shall be the weight in pounds of the blade, expressed in decimal form; the second shall be the distance in inches from the center of rotation to the center of gravity of the blade; the third shall be the distance in percent mean aerodynamic chord (MAC) from the leading edge of the blade to the center of gravity of the blade chordwise (Example: 57.2-75.5-32.4, when the blade has a weight of 57.2 pounds with the center of gravity 75.5 inches from the center of rotation and with the chordwise center of gravity at 32.4 percent MAC). Stenciling, 1/2 inch to 1 inch in height, shall be accomplished with a paint or dope that contrasts well with the color of the blade. The preceding information shall be marked on the flat surface on the ground side of each blade at the inboard or butt end of the main rotor blade.

3.7.3.2.3.1.1 Unmatched sets.- For unmatched sets of main rotor blades, orange-yellow warning stripes, Fed. Std. color No. 33438, shall be applied to both sides of the blades from the tip to 6 inches from the tip, as shown on figure 3.

3.7.3.2.3.1.2 Matched sets.- For matched sets of main rotor blades, individual identification stripes shall be painted on both sides of the blade from the tip to 2 inches from the tip. This stripe shall be insignia white, Fed. Std. color No. 17875 for one blade, insignia red, Fed. Std. color No. 11136 for the second blade, and light green, Fed. Std. color No. 14187 for the third blade. In addition, orange-yellow warning stripes, Fed. Std. Color No. 33538, shall be applied inboard of the 2-inch stripe on both sides of the blade, and extending from the line 2 inches from the tip to a line 8 inches from the tip, as shown on figure 3.

MIL-M-25047C(ASG)

3.7.3.2.4 Tail rotor blades. - Tail rotor blades shall be identified as follows:

3.7.3.2.4.1 Tail rotor blades. - Tail rotor blades shall be finished as shown on figure 3, starting from the tip and on both sides of the blade, as follows:

- (a) A 6-inch wide band of bright red, Fed. Std. color No. 31136.
- (b) A 6-inch wide band of insignia white, Fed. Std. color No. 17875.
- (c) A 6-inch wide band of bright red, Fed. Std. color No. 31136.
- (d) A non-specular black band, Fed. Std. color No. 37038, to within 6 inches of the hub.
- (e) A 6-inch wide band of bright red, Fed. Std. color No. 31136.

* 3.7.3.2.4.2 Helicopter tail boom warning marking. - For helicopters having tail rotor blades revolving in the vertical plane, a warning sign shall be painted on both sides of the tail boom, as shown on figure 4. This shall consist of a 33-inch wide orange-yellow band, Fed. Std. color No. 33538, encircling the tail boom. Centrally superimposed on this band shall be applied a bright red arrow, Fed. Std. color No. 31136, of appropriate size, with the arrow pointing aft as indicated on figure 4. Above the arrow shall appear the word "DANGER" and below the arrow shall appear the words "KEEP AWAY". The letters shall be black, and shall be approximately 2 inches in height. If temporary fluorescent paint conforming to MIL-P-21600 is applied on the tail boom, this paint shall be applied over the orange-yellow band, except that the red arrow and warning legend shall remain visible in a rectangle of appropriate size.

3.7.3.2.4.3 Helicopter tail rotor guards and stabilizers. - On helicopters with tail rotor guards and/or stabilizers, the tail rotor guard and/or stabilizer shall have warning markings applied to prevent ground personnel from accidentally running into these components. The markings shall consist of 2-inch wide alternating stripes of orange-yellow, Fed. Std. color No. 33538, and bright red, Fed. Std. color No. 31136.

3.7.3.3 Arresting hooks. - Arresting hooks shall be painted with gloss black, Fed. Std. color No. 17038, and insignia white, Fed. Std. color No. 17875, alternate bands, 4 inches wide, to produce maximum visibility. Paint shall not be applied to the arresting hook point.

* 3.7.3.3.1 Arresting hook warning marking. - For aircraft having arresting hooks, a warning sign shall be painted on both sides of the fuselage (see figure 5) and shall be located in proximity to the hook point when in the retracted position. The marking shall be clearly visible to maintenance personnel approaching from

MIL-M-25047G(ASG)

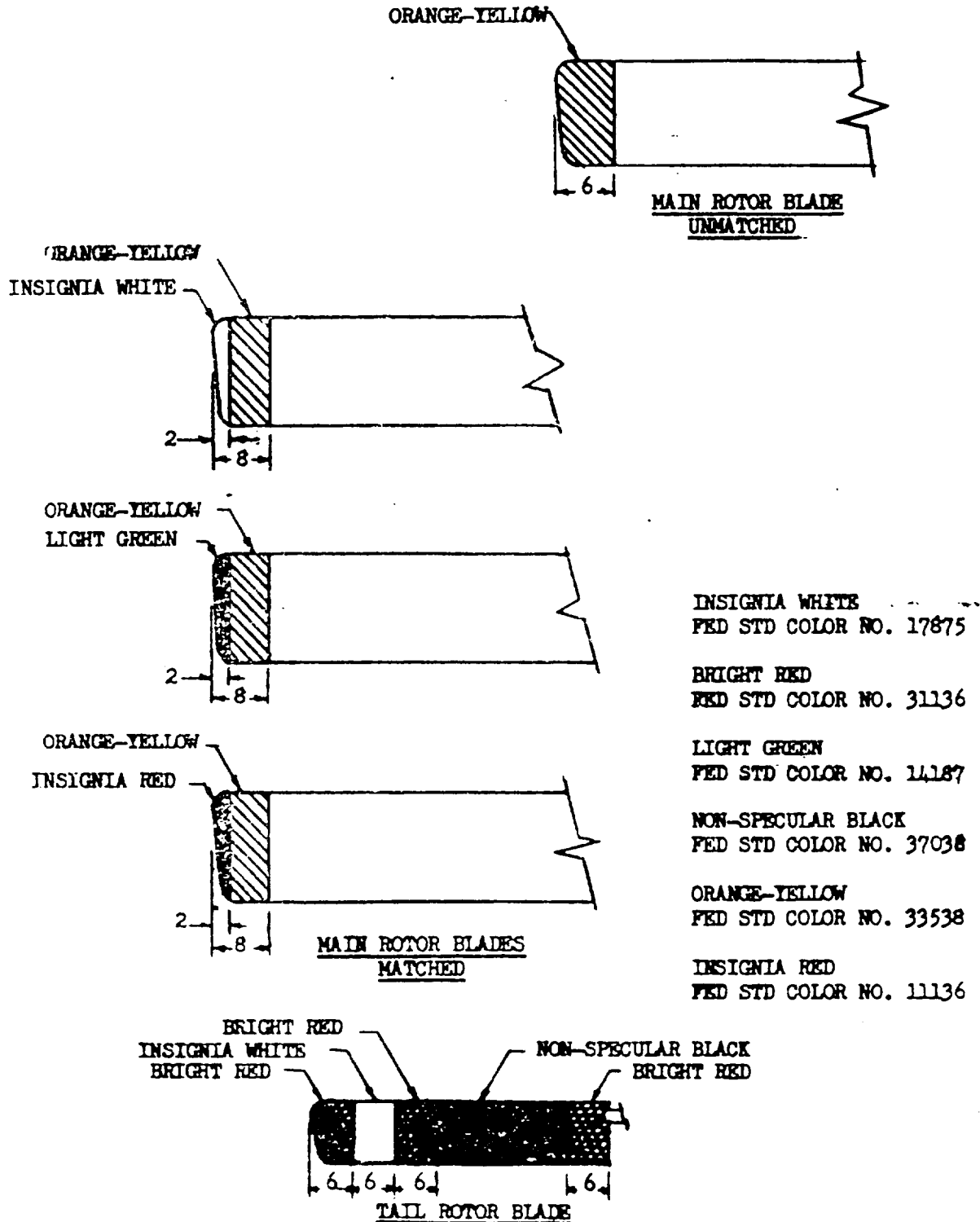

FIGURE 3. Color scheme for helicopter rotor blades

MIL-M-25047C (ASG)

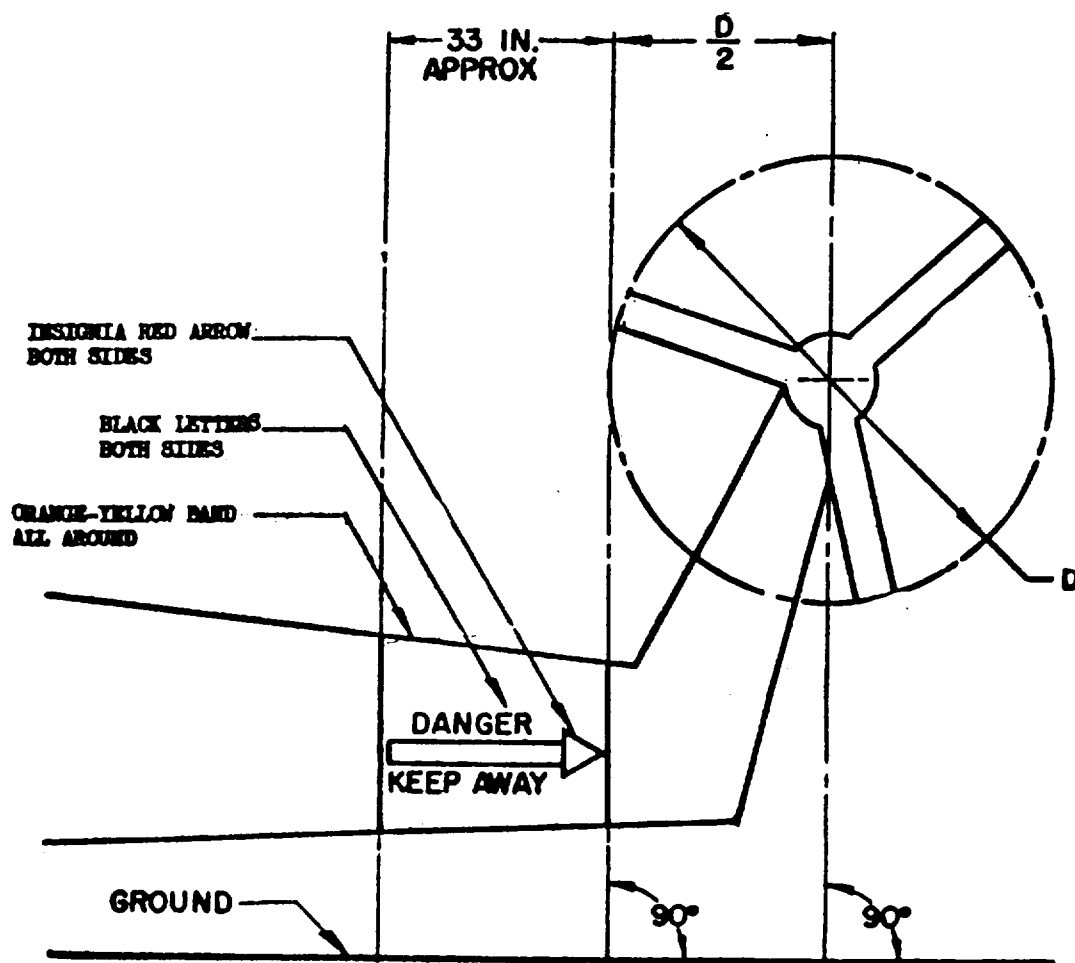

FIGURE 4. Warning marking for helicopter tail boom

MIL-M-25047C(ASG)

either side of the aircraft or when working under the aircraft. The letters and arrows shall be bright red, Fed. Std. color No. 31136. The letters shall be superimposed on a stripe of insignia white, Fed. Std. color No. 37875. The height of the letters and the width of the arrows shall be 2 inches. The arrow length shall be approximately 4 inches.

- * 3.7.3.4 Speed brakes, wing flaps, etc., (for Navy).- Interior surfaces of speed brakes and wing flaps shall be colored insignia red, Fed. Std. color No. 11136. Areas covered by wing flaps when in the retracted position shall also be colored insignia red.
- * 3.7.3.5 Wing leading edge slats (for Navy).- The interior surface and inboard end of wing leading edge slats and the wing area covered by the slat when in a fully retracted position shall be colored insignia red, Fed. Std. color No. 11136. The underside of the wing leading edge slats of carrier type aircraft, i.e., airplanes having white undersurfaces, shall be colored insignia white, Fed. Std. color No. 17875, for thermal pulse reflection.
- * 3.7.3.6 Jet engine intake warning chevrons and signs (for Navy).- The areas of the leading edge of the wing, or the areas of the fuselage, or the areas of the nacelle or pod, or combination thereof, which are adjacent to the sides of a jet engine intake shall be marked with warning chevrons and signs, as specified in the following subparagraphs.

3.7.3.6.1 The chevrons shall be applied so that the ends of their outer sides contact the edge of the intake at points which are three-quarters of the diameter, or three-quarters of the short axis, of the intake port. The outer points of the chevrons shall be located a distance of 4 feet outboard along the leading edge of the wing, or forward or aft, if applied on the fuselage, or aft, if applied on the nacelle or pod, from the center of the intake. The chevrons shall be 3 inches in width, and shall be marked in insignia red. Superimposed on one side of a chevron shall be the word "JET" and on the other side the word "INTAKE" in insignia white. The letters shall be 2 inches in height. The words "DANGER" (with an arrow pointing in juxtaposition to the point of the chevron) and (an arrow pointing in juxtaposition to the point of the chevron) "DANGER" shall be applied along the leading edge of the wing, or on the fuselage, nacelle, or pod, as applicable. The letters and arrows shall be marked in insignia red and shall be superimposed on a stripe of insignia white, 3 inches in width. The height of the letters and length of the arrows shall be 2 inches.

3.7.3.6.2 The dimensions specified above shall be adhered to in general; however, they may be varied, and the words "DANGER" with the arrows required pointing to the edge of the intake may be applied within the V of the chevrons, if due to space limitations or other considerations. The general outline and appearance of the warning chevrons shall conform to figures 6, 7, and 8.

- * 3.7.3.6.3 Jet engine blast warning (for Navy).- The areas of the fuselage or the areas of the nacelle or pod, or combination thereof, which are adjacent to the sides of a jet engine exhaust shall be marked with the words "BEWARE OF BLAST" as shown on figures 7 and 8.

MIL-M-25047C (ASG)

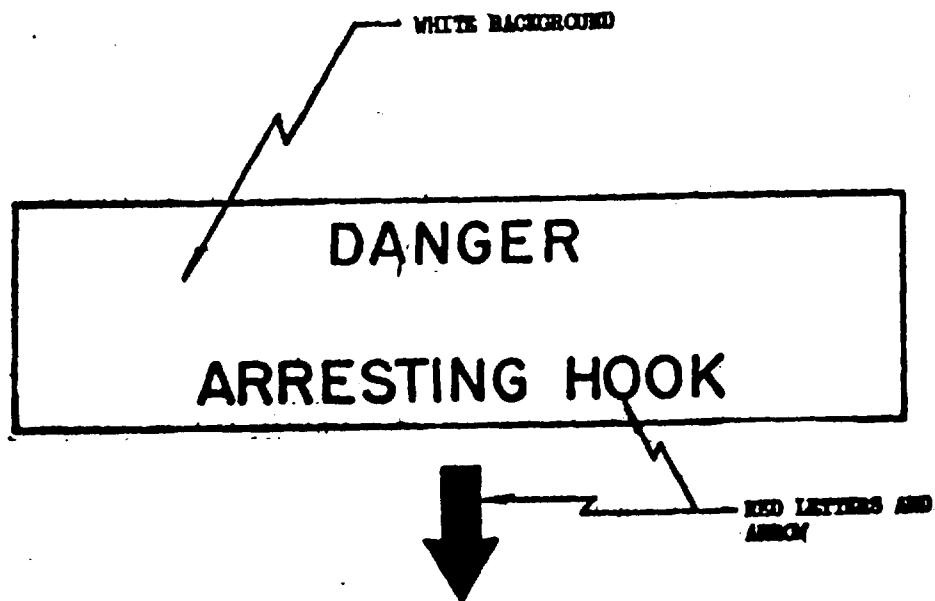

FIGURE 5. Aircraft hook-point warning marking

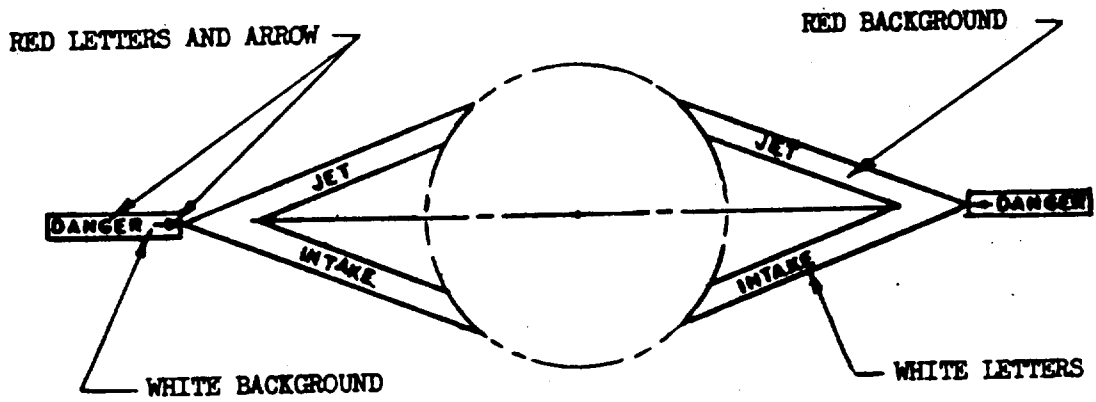

FIGURE 6. Warning chevrons and signs applied adjacent to jet engine intakes

MIL-M-25047C (ASG)

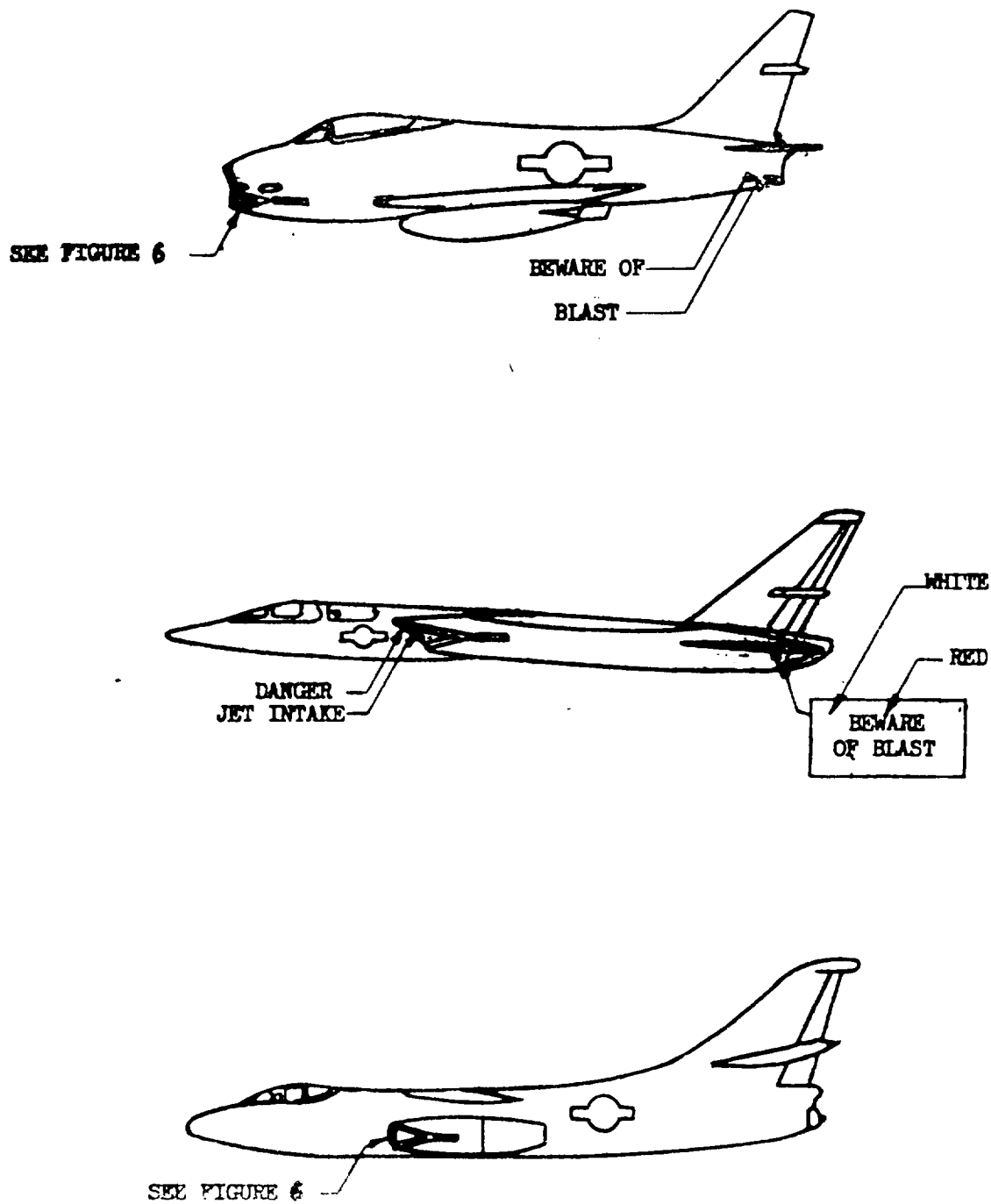
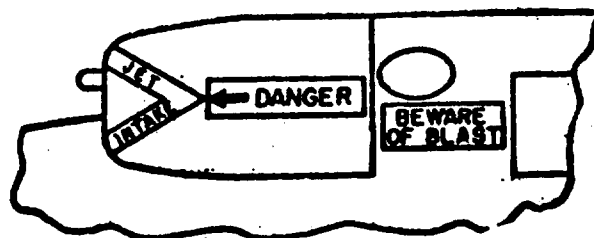

FIGURE 7. Jet aircraft intake and blast warning markings



DETAIL A

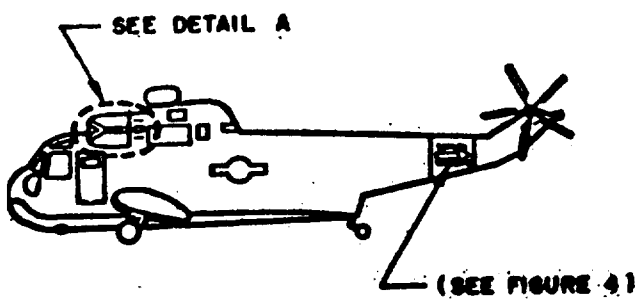

FIGURE 8. Helicopter intake and blast warning markings

MIL-M-25047C(ASG)

3.7.4 Emergency escape markings. -- All markings and markers used to identify or explain the operation of emergency escape facilities shall be in accordance with MIL-A-25165. (See 6.3.)

3.7.5 Walkways and honeycomb panels. - Walkways and honeycomb panels shall be marked as follows.

3.7.5.1 Walkways and steps. - In cases where they do not contrast in color with adjacent areas, walkway areas shall be bounded by a camouflage black line for a light background or a camouflage white line for a dark background, 1/2 inch wide, and marked with the word "WALKWAY" at sufficiently frequent intervals to indicate the walkway area. Steps shall be suitably indicated at all points on the aircraft.

* 3.7.5.2 Honeycomb panels on airplanes. - Honeycomb panels (thin skin) for wing upper surfaces shall be distinctly marked by a 1-1/2 inch wide stripe of hash marks; each hash mark shall be 2 inches long, measured along the stripe with 2 inches between marks. The marks shall slope 45 degrees. The markings shall be painted on, with a material which is compatible with the finish on the aircraft, in the area of application.

3.7.6 Powerplant. - Powerplants shall be marked as follows.

* 3.7.6.1 Powerplant removal. - When making a powerplant assembly change, all systems, lines, conduits, control rods, cables, bell-cranks and casting flanges shall be marked at the point of disassembly. The marking shall be a painted band not exceeding 1 inch in width, of a material which is compatible with the finish on the aircraft, in the area of application.

3.7.6.1.1 Recessed lubrication fittings. - Flush type (female receptacle) grease fittings, recessed set screws, or depressed adjustments, such as may be found on rotor controls and drive shafts, but which require periodic servicing or inspection, shall be identified with a circumscribed band of orange, color No. 12197 of Fed. Std. No. 595 not exceeding 1 inch in width.

3.7.6.2 Powerplant controls. - All engine control units shall be clearly marked in the vicinity of the lever and in such position that the lever marking association is clear, as follows:

<u>Control</u>	<u>Extreme positions</u>	
Throttle	Open	Closed
Mixture	(See 3.7.6.2.1)	
Shutter	Open	Closed
Carburetor heat	Hot	Cold
Propeller	Decrease rpm	Increase rpm
Supercharger (if turbo)	On	Off
Supercharger (if 2-speed geared)	High	Low

MIL-M-25047C(ASG)

In marking the control levers, the abbreviations T, M, S, P, and B may be used for the throttle, mixture toggle switch, propeller, and supercharger levers, respectively. Standard control knobs (other than landing gear and fire extinguisher) shall be gray, color No. 16473 of Fed. Std. No. 595.

3.7.6.2.1 Mixture control lever. - A plate on which the carburetor control positions are marked shall be installed adjacent to the mixture control lever. The markings shall be white letters on a black background, except IDLE CUT-OFF, which shall be white lines on a red background. The lines shall indicate the position of the middle of the control lever when the lever on the carburetor is in the appropriate notch.

3.7.6.3 Fuel system diagram. - A fuel system diagram shall be provided in the cockpit of each aircraft. The fuel system diagram shall be a simple schematic layout of the fuel system with the fuel selector valve or valves displayed in a prominent manner. Lines such as normal tank vent lines, primer lines, and pressure-gage lines need not be shown on the fuel system diagram, which is intended to aid the pilot in obtaining a clear picture of that part of the fuel system with which he is concerned in flight. All fuel system diagrams shall be of sufficient size and clearance for the purpose intended.

3.7.7 Fluid line identification. - All fluid lines shall be marked in accordance with MIL-STD-1247 (see 6.3).

* 3.7.7.1 Color code (identification chart). - Identification chart color codes in accordance with MIL-STD-1247 shall be installed in all aircraft, as follows:

- (a) One identification chart color code shall be installed in each engine nacelle on all aircraft for the use of ground crews. For multiengine aircraft, additional identification chart color codes shall be installed, one per engine, at random (bomb bay between nacelles where the piping becomes exposed upon removal of cowlings, etc.).
- (b) Identification chart color codes are not needed in single-place aircraft for the use of the pilot. One such code shall be installed at each crew station in two-place aircraft and one shall be installed near each crew station in multi-place aircraft, with a maximum of four per aircraft.

3.7.8 Data cards. - Data cards and check lists shall be mounted in the cockpit or in an accessible position. These cards shall be given a coat of clear shellac or other transparent protective material. A Vandyke drawing of the data cards, properly filled in, shall be furnished with drawings, in
* accordance with MIL-D-1000.

3.7.9 Marking of loose and jettisonable equipment. - The following loose equipment shall be marked in a contrasting color, using a stencil or other suitable
* marking, with the radio call numbers: Life rafts; tool kits peculiar to the airplanes; aircraft covers, that is, engine covers, dust covers, etc.; equipment

MIL-M-25047C(ASG)

specifically calibrated for the airplanes, such as drift meters, tuning units, etc., and jettisonable equipment such as canopies, wing tanks, and ejection seats. Ejection seats shall include abbreviation of the operator, such as PLT, CO-PLT, NAV.

3.7.10 Reworked or special parts.- Parts, equipment, and assemblies, including special bolts and reworked items as altered or selected for special fit, performance, or tolerance, shall be marked in accordance with MIL-STD-130. Such markings shall be accomplished in a manner that will not adversely affect the life and utility of the item.

3.8 Conspicuity marking (see and be seen).- Paint coatings for conspicuity marking on all aircraft, except those exempted by Department of the Air Force Directive, "Arctic Marking", applied to aircraft destined for operation in cold-weather areas and for drone aircraft, shall conform to MIL-P-21563. Location and configuration of pattern shall be in accordance with the applicable technical order for US Air Force, or MIL-I-18464 for US Navy (see 6.2).

3.8.1 Fluorescent painting.- Flight-sensitive equipment, which includes propellers, turrets, radomes, external antenna assemblies, refueling boom assembly, wing and empennage de-icers, fabric-covered flight controls, and aluminum-covered flight controls, located within the arctic marking pattern, shall not be fluorescent painted (see 3.2.3).

3.9 National star insignia and standard identification marking (US Air Force only).- Unless otherwise specified by the procuring activity, the national star insignia and the following standard identification markings shall be applied to the external surface of all aircraft, helicopters, convertiplanes, and missiles (ballistic missiles excluded). (See 6.2 for details on surface preparation and marking location.) (For Navy, see MIL-I-18464.)

<u>Marking</u>	<u>General location</u>
Insignia	Wing and fuselage
USAF	Wing
US AIR FORCE	Fuselage
Identification	
Aircraft	Fuselage
Missile	Vertical fin
Radio call number	
Aircraft	Vertical fin
Serial number and fuel requirements	Fuselage

3.9.1 National star insignia.- The national star insignia, conforming to MIL-I-6140, unless otherwise exempted herein, shall be applied on the upper surface of the left wing and on the lower surface of the right wing of all aircraft and winged missiles or missiles equipped with guide vanes.

MIL-M-25047C(ASG)

3.9.1.1 The wing insignia or other markings shall be omitted from the underside of wings or other surfaces on which thermal-resistant finishes are applied (see 3.2.3).

3.9.1.2 Fuselage insignia.— The national star insignia conforming to MIL-I-6140, unless otherwise exempted herein, shall be applied to either side of the fuselage of all aircraft and missiles. Symmetry shall be maintained when applying the insignia to each side of the fuselage. The national star insignia may be omitted from the fuselage of aircraft when application would * interfere with the aircraft identification or the marking "US AIR FORCE" (see 3.2.3).

3.9.1.3 Helicopter and convertiplane insignia.— Four national star insignia shall be applied to aircraft of this type in such a manner as to be identified visibly from either side, from above, and from below. If space limitations and configuration permit, an additional insignia may be applied to the nose of helicopters to provide more positive identification. The insignia shall conform to MIL-I-6140. Symmetry for size and location shall be maintained on all like model series helicopters.

3.9.2 Standard identification marking.— Standard identification marking shall be as follows.

3.9.2.1 Wing marking.— The marking "USAF" shall be placed on the lower surface of the left wing and the upper surface of the right wing of all aircraft and winged missiles or missiles equipped with guide vanes. The height of this marking shall correspond, insofar as possible, with the outside border diameter of the national star insignia located on the opposite wing of the aircraft. The width of the letters shall be three-fourths and the stroke one-sixth of the letter height (see 3.4). This marking may be omitted from the underside of the wing or other surfaces on which thermal-resistant finishes are applied (see 3.2.3).

3.9.2.2 U. S. Air Force marking, aircraft and missiles.— U. S. Air Force markings shall be as follows.

3.9.2.2.1 The markings "U.S. AIR FORCE" shall be placed on each side of the fuselage of all USAF Aircraft and winged missiles, including missiles equipped with guide vanes. Aircraft assigned to other Services or the National Guard shall not be included. The height and location of the lettering may vary on aircraft of different size and model in accordance with the location and space available, but the size of this marking shall be symmetrical on all aircraft and missiles of the same model series (see 3.4 and 6.2).

NOTE: Missiles viewed in an attitude of 60 degrees or greater to the horizon are considered vertically viewed missiles. Missiles viewed in an attitude of less than 60 degrees to the horizon are considered horizontally viewed missiles.

3.9.2.2.1.1 Horizontally viewed missiles.— On horizontally viewed missiles, the marking "U.S. AIR FORCE" shall be placed and maintained on each side of the fuselage as near as practicable to the horizontal centerline, reading from left to right.

MIL-M-25047C(ASG)

3.9.2.2.1.2 Vertically viewed missiles.- On vertically viewed missiles, the marking "US AIR FORCE" (with the period after U and S omitted) shall be placed and maintained on each side of the fuselage on the centerline, as near the nose as practicable, reading from top to bottom with the missile in a position ready for launching.

3.9.2.3 Radio call number (aircraft only).- Radio call numbers shall be as follows.

* 3.9.2.3.1 Each aircraft, except primary trainers not having radio equipment, shall have a radio call number painted on each side of the vertical stabilizer surface or on each outboard side, as applicable. The numbers or designators shall be discernible at a distance of 50 yards. The number height shall be no less than 9 inches; however, if space does not permit a height of 9 inches, the height shall be as large as possible. The radio call numbers shall consist of not less than five numerals and shall be derived from the aircraft serial number. Arabic numbers shall be used when applying call numbers. The first numeral of the contract year and the hyphen in the aircraft serial number shall not be used in the call number. If five numerals are not available in the aircraft serial number from which to derive five numerals for a radio call number, zeros shall be used to produce five numerals. Should more than five numerals be available, the last five numerals of the aircraft serial number shall be used. Since numbers once assigned may reach an age of 10 years or more, there is a possibility that two sets of radio call numbers could be identical. To prevent this, the symbol "0-" shall precede derived numbers of more than 10 years of age.

Examples:

No. 1.	For serial No. 59-5434,	use 95434
No. 2.	For serial No. 59-653472,	use 53472
No. 3.	For serial No. 59-7,	use 90007
No. 4.	For serial No. 60-7,	use 00007
No. 5.	For serial No. 50-7,	use 0-0007

3.9.2.4 Serial number and fuel requirements, aircraft and missiles.- Serial numbers and fuel requirements shall be as follows.

3.9.2.4.1 Aircraft serial number.- The following markings, properly filled in, shall be stenciled on the left side of the fuselage, near the pilot's compartment:

US Air Force (model designation)

Serial No. _____ A

The military component assignment symbol "A" for Air Force shall appear as a suffix immediately following the serial number. Capital letters shall be used, plainly visible from the ground. The letter size shall be commensurate with the following requirements:

MIL-M-25047C(ASG)

<u>Top of forward fuselage above ground level</u>	<u>Letter size</u>
0 through 144 inches	1 inch
145 through 216 inches	2 inches
217 inches, and over	3 inches

3.9.2.4.1.1 Fuel requirement.- Fuel requirement shall appear on all aircraft separated by one space and immediately below the aircraft serial number:

SERVICE THIS AIRCRAFT WITH
GRADE _____ FUEL

(For fuel grades, see 6.2; for letter size, see 3.9.2.4.1.)

3.9.2.4.2 Missile serial numbers.- The missile serial number shall be placed immediately under the U. S. Military Service marking; normally, the letter size shall be commensurate with 3.9.2.4.1. The U.S. Military Service serial number shall be applied by stencil rather than freehand lettering.

3.10 Aircraft and missile service point identification symbols and markings.- Service point identification and precautionary warning markings shall be applied on all aircraft and missiles. Each marking shall be displayed to provide the following (see 6.3):

- (a) Rapid identification of each required servicing point
- (b) Identification of type of ground servicing required
- (c) Display of warning or safety precautions which will prevent injury to personnel or damage to equipment

3.10.1 Servicing instructions for hydraulic systems, landing gear shock struts, tires and wheels, hydraulic reservoirs, and pneumatic systems may be provided on metal instruction plates or stenciled in a permanent and legible manner adjacent to charging points or test connections.

3.10.2 Paint or decals may be used when applying service point identification and precautionary warning markings. When paint is used, stencils incorporating capital letters and Arabic numerals not to exceed 1-1/4 inch in height shall be employed as opposed to freehand applications. The color shall be black when applied on aluminum surfaces, yellow for camouflage finishes other than black, and red on black finishes. Decalcomanias conforming to MIL-D-8634, MIL-D-8635, and MIL-P-38477 may be used in lieu of paint (see 3.6).

3.10.3 The location of each marking shall be predicated on existing available space. Markings may be situated on the equipment concerned, directly below, adjacent to, or on applicable access panels. In the event the service point or marking is concealed, arrows may be used to point out the location of the service point or marking. The arrow should bear a brief identification, or the applicable service point identification, or a precautionary warning marking.

MIL-M-25047C(ASG)

3.10.4 Service point identification markings.- Service point marking symbols shall not exceed 4 inches in width or height. In areas that will not accommodate this size, the next smaller size markings may be used, consistent with existing available space.

3.10.5 Service point markings shall conform to MS33739. A decal similar to that shown on MS33739, defining the location of servicing points shall be located inside the nose wheel well or nose wheel door.

3.10.6 Precautionary or warning markings.- Precautionary or warning markings shall be in accordance with 3.10.7 through 3.10.18.

3.10.7 Fuel nozzle jumper plug receptacles.- Fuel nozzle plug receptacles shall be marked in accordance with MS33645.

3.10.8 Storage batteries.- The notation "BATTERY" shall be painted in red letters 1 inch high on battery access doors. The notation "BATTERY LOCATION _____", with the exact location, shall be placed on the left side of the fuselage when viewed from the rear of the aircraft. The fore and aft location of the markings shall be approximately in line with the trailing edge of the wing. The vertical location of the markings shall be at a point 2 to 3 feet off the ground with the airplanes in the wheel-up position and resting on the ground or, in the case of airplanes having fixed landing gears, with the landing gear washed out. In the event of interference with windows, enclosures, etc., the marking shall be placed as near to the aforementioned location as practicable.

3.10.9 Instrument static opening markings.- Instrument static openings shall not have any finish applied within a 1-inch diameter circle around the opening. A red 1/2-inch wide circular band shall be applied around this unpainted area. The following legend shall also be applied adjacent to the marking "INSTRUMENT STATIC OPENING - DO NOT COVER".

3.10.10 Wing fold warning flag.- On aircraft having wing fold warning flags, the flags shall be painted red, Fed. Std. color No. 31136.

3.10.11 Markings for electrical connections.- The following caution note shall be placed at points where it is necessary to break electrical connections when folding back or removing wings; or removing tail surfaces, etc:

CAUTION

Disconnect electrical wiring before removing part.

3.10.12 Markings for tank areas.-

3.10.12.1 Tanks.- Aircraft tanks shall have notations indicating tank capacity, type of liquid, and level restrictions. Tank markings shall be the same color as that used on attaching lines. Additional data, such as coolant mixture, water-alcohol mixture, and grade of liquid shall be stenciled near the

MIL-M-25047C(ASG)

filler caps in letters 1/2 inch high in the same color as that used to indicate tank capacity. The following shall be the terminology for stenciling fuel tanks:

USE _____ OCTANE FUEL OR BETTER, OR USE GRADE _____
OR BETTER, AS APPLICABLE.

3.10.12.2 Filler caps. - Filler caps for fuel and oil tanks, and other external parts and attachments for which identification is necessary and desirable shall be painted the color assigned to the fitting concerned and shall be indicated by appropriate markings. Where flush type pressure fueling caps in conformance with MS29525 are installed, three radial black lines 3/8-inch wide by 1-inch long, Fed. Std. color No. 37038, shall be so located as to form extension to the lines on the cap when the cap is in the locked position. The type and grade of fuel to be employed in the aircraft shall be indicated adjacent to the filler caps in accordance with MS33739.

3.10.13 Compartment marking, transport aircraft. - The compartments of transport aircraft shall be marked with individual compartment horizontal dimensional limits, the compartment centroids, the compartment letter designations, and the compartment maximum structural capacity in pounds. Cargo compartments shall also be marked in inches from the horizontal reference datum at 20-inch intervals (see figure 9).

3.10.14 Lift points, hand grips, caution legends, etc. - These shall be indicated by appropriate wording painted adjacent to the point concerned.

3.10.15 Baggage compartment, life raft stowage, etc. - These shall be indicated by means of appropriate signs painted adjacent to the area concerned.

3.10.16 Wing access panel latches and safety straps. - On aircraft which have wing access panel latches and safety straps, the inside lever and wing area under the latch safety strap shall be painted an insignia red, Fed. Std. color No. 11136, in such a manner that no red color will show when the latches and straps are properly secured.

3.10.17 Wing-tip tank fins warning markings. - Aircraft having wing-tip tanks with fins installed in such a manner that the fins extend outboard in a horizontal plane, and which fins are such a distance from the ground that personnel may walk into them inadvertently, shall have warning markings applied. The markings shall consist of an orange-yellow band, Fed. Std. color No. 33538, encircling the fin from the tip to a distance 2 inches inboard from the tip, followed by a bright red band, Fed. Std. color No. 31136, encircling the fin from a distance 2 inches inboard from the tip to a distance 4 inches inboard from the tip.

3.10.18 Actuating mechanism warning signs. - A warning sign shall be located adjacent to any actuating mechanism which can cause damage to the weapons systems from improper or out-of-sequence operation.

MIL-M-25047B(AS7)

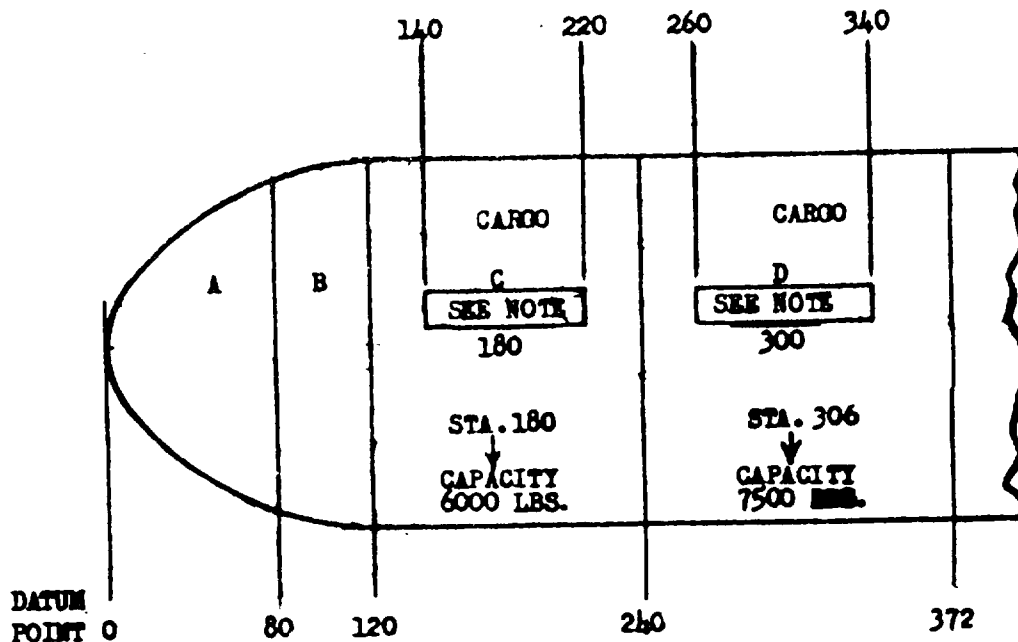
**NOTE:**

THE FOLLOWING INSTRUCTIONS SHALL BE PLAINLY VISIBLE IMMEDIATELY UNDER OR ADJACENT TO THE COMPARTMENT IDENTIFICATION SYMBOL, "FOR COMPLETE LOADING RESTRICTIONS CONSULT TECHNICAL ORDER 1-1B-40 OR APPLICABLE AIRCRAFT T.O.-9 CARGO LOADING." LETTERS SHALL NOT EXCEED 1 INCH IN HEIGHT.

DIMENSIONS IN INCHES.

FIGURE 9. Compartment marking

3.10.19 Float marking. -

3.10.19.1 Handling truck markings. - The handling truck markings shall be applied by means of a black stripe, 2 inches wide, extending a sufficient distance to provide clear definition of function and boundary.

3.10.19.2 Warning stripe and signs. - The area of the float which is in the plane of the propeller path shall be marked with an insignia red stripe, 3 inches wide, extending from chine to chine. The word "PROPELLER", reading vertically from the center of the deck to the chine, on both sides, shall be superimposed on the stripe in insignia white letters, 2 inches in height, at sufficiently frequent intervals to indicate the dangerous area. The signs "DANGER" and "DANGER" shall be applied perpendicular to and centered with respect to the word "PROPELLER", one sign on each side thereof, with the arrow pointing toward the stripe. The letters and arrows shall be insignia red, and shall be superimposed on a stripe of insignia white, 3 inches wide. The height of the letters and length of the arrows shall be 2 inches.

3.11 Additional markings, as required, may be used in conjunction with symbols and markings specified herein only as authorized in accordance with this specification.

3.12 Workmanship. - Particular attention shall be given to freedom from blemishes, accuracy, location, and visibility of dimensions and marking of parts and assemblies throughout. Workmanship shall conform to commercial practice covering this type of work.

4. QUALITY ASSURANCE PROVISIONS

4.1 The methods and all materials entering into the marking of airplanes shall be subject to inspection by the procuring activity. When inspection is performed at the contractor's plant, tests shall be performed by the contractor under the supervision of the procuring activity.

5. PREPARATION FOR DELIVERY

5.1 Not applicable to this specification.

6. NOTES

6.1 Intended use. - This specification is intended to provide a uniform overall marking system for distinguishing insignia, identification, and other special purpose markings for all aircraft, missiles, and parts thereof.

6.2 General. - It is the obligation of the contractor or overhaul activity to be familiar with the following documents for various phases and details pertaining to size and location of identification and special purpose markings, toxicity of solvents used, preparation of surface, application of materials, designation and serial numbers, NATO code markings, fuel requirements, and compartment marking:

T. O. 1-1-4	External Finishes, Insignia and Markings Applicable to USAF Aircraft and Missiles
MIL-I-18464	Insignia and Markings for Naval Weapons Systems

MIL-M-25047C(ASG)

- * 6.3 International standardization. - Certain provisions (3.7.3.1, 3.7.7, 3.10.3, 3.10.4, and 3.10.13) of this specification are the subject of international standardization agreements (ASCC 11/1, 17/3, and 51/2, and STANAGS 3104, 3109, and 3230). When amendment, revision, or cancellation of this specification is proposed, the departmental custodians will inform their respective Departmental Standardization Offices so that appropriate action may be taken respecting the international agreement concerned.
- * 6.4 Marginal indicia. - The margins of this specification are marked to indicate where changes, deletions, or additions to the previous issue have been made. This is done as a convenience only and the Government assumes no liability whatsoever for any inaccuracies in these notations. Figures are not so marked. Bidders and contractors are cautioned to evaluate the requirements of this document based on the entire content as written, irrespective of the marginal notations and relationship to the last previous issue.

* Custodians:

Navy - AS
 Air Force - 11
 International interest(see 6.3)

Preparing activity:

Air Force - 11

Project No. 1500-F001

* Reviewer activities:

Navy - AS
 Air Force - 11, 70, 84

INSTRUCTIONS: In a continuing effort to make our standardization documents better, the DoD provides this form for use in submitting comments and suggestions for improvements. All users of military standardization documents are invited to provide suggestions. This form may be detached, folded along the lines indicated, taped along the loose edge (*DO NOT STAPLE*), and mailed. In block 5, be as specific as possible about particular problem areas such as wording which required interpretation, was too rigid, restrictive, loose, ambiguous, or was incompatible, and give proposed wording changes which would alleviate the problems. Enter in block 6 any remarks not related to a specific paragraph of the document. If block 7 is filled out, an acknowledgement will be mailed to you within 30 days to let you know that your comments were received and are being considered.

NOTE: This form may not be used to request copies of documents, nor to request waivers, deviations, or clarification of specification requirements on current contracts. Comments submitted on this form do not constitute or imply authorization to waive any portion of the referenced document(s) or to amend contractual requirements.

(Fold along this line)

(Fold along this line)

DEPARTMENT OF THE AIR FORCE



NO POSTAGE
NECESSARY
IF MAILED
IN THE
UNITED STATES

OFFICIAL BUSINESS
PENALTY FOR PRIVATE USE \$300

BUSINESS REPLY MAIL

FIRST CLASS PERMIT NO. 73236 WASHINGTON D. C.

POSTAGE WILL BE PAID BY THE DEPARTMENT OF THE AIR FORCE

ASD/ENESS
Wright-Patterson AFB, OH 45433

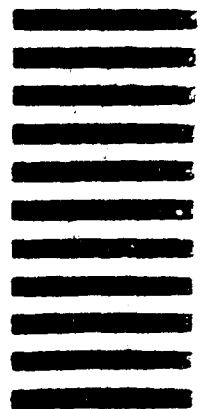

STANDARDIZATION DOCUMENT IMPROVEMENT PROPOSAL

(See Instructions - Reverse Side)

1. DOCUMENT NUMBER

2. DOCUMENT TITLE

3a. NAME OF SUBMITTING ORGANIZATION

4. TYPE OF ORGANIZATION (Mark one)

 VENDOR USER MANUFACTURER OTHER (Specify): _____

b. ADDRESS (Street, City, State, ZIP Code)

5. PROBLEM AREAS

a. Paragraph Number and Wording:

b. Recommended Wording:

c. Reason/Rationale for Recommendation:

6. REMARKS

7a. NAME OF SUBMITTER (Last, First, MI) - Optional

b. WORK TELEPHONE NUMBER (7 digit Code) - Optional

c. MAILING ADDRESS (Street, City, State, ZIP Code) - Optional

8. DATE OF SUBMISSION (YYMMDD)