

MIL-L-85314/1A
30 June 1983
SUPERSEDING
MIL-L-85314/1
27 December 1982

MILITARY SPECIFICATION SHEET

LIGHT SYSTEMS, ROTARY WING AIRCRAFT, ANTI-COLLISION, STROBE, DUAL (RED AND WHITE) MODE, FUSELAGE MOUNTED

This specification is approved for use by all Departments and Agencies of the Department of Defense.

The complete requirements for acquiring the light systems described herein shall consist of this document and the latest issue of Specification MIL-L-85314.

1. SCOPE

1.1 Scope. This detail specification together with the general specification cover the requirements for dual (red and white) mode, strobe, anti-collision light systems for rotary wing aircraft.

1.2 Classification. The classification (types) of the light systems shall be as specified in the general specification.

2. APPLICABLE DOCUMENTS

2.1 Government documents.

2.1.1 Specifications, standards, and handbooks. Unless otherwise specified, the following specifications, standards, and handbooks of the issue listed in that issue of the Department of Defense Index of Specifications and Standards (DoDISS) specified in the solicitation, form a part of this specification to the extent specified herein.

SPECIFICATIONS

Military

DOD-C-38999/40 Connectors, Electrical, Circular, Miniature, High Density, Quick Disconnect (Bayonet, Threaded, and Breech Coupling), Environment Resistant, Removable Crimp and Hermetic Solder Contacts, Receptacle, Wall Mounting Flange, Breech Coupling, Removable Crimp Contacts, Series IV, Metric

FSC 6220

MIL-L-85314/1A

SPECIFICATIONS (Continued)

Military (Continued)

DOD-C-38999/42	Connectors, Electrical, Circular, Miniature, High Density, Quick Disconnect (Bayonet, Threaded, and Breech Coupling), Environment Resistant, Removable Crimp and Hermetic Solder Contacts, Receptacle, Box Mounting Flange, Breech Coupling, Removable Crimp Contacts, Series IV, Metric
DOD-C-38999/46	Connectors, Electrical, Circular, Miniature, High Density, Quick Disconnect (Bayonet, Threaded and Breech Coupling), Environment Resistant, Removable Crimp and Hermetic Solder Contacts, Plug, Breech Coupling, EMI Grounding, Removable Crimp Contacts, Series IV, Metric
MIL-L-85314	Light Systems, Aircraft, Anti-Collision, Strobe, General Specification for

(Copies of specifications, standards, handbooks, drawings, and publications required by manufacturers in connection with specific acquisition functions should be obtained from the contracting activity or as directed by the contracting officer.)

3. REQUIREMENTS

3.1 First article. The strobe, anti-collision, aircraft light systems furnished under this specification shall be products which have been inspected and passed first article inspection. Each type shall be inspected separately.

3.2 Materials and components. Materials and components shall conform to applicable specifications, standards and figures as listed or required herein and unless modified herein to the general specification for the strobe, anti-collision, aircraft light systems, MIL-L-85314.

3.3 Design and construction. The design and construction of the rotary wing aircraft light systems shall comply with the general specification, except as otherwise specified herein.

3.3.1 Operation. The operation of the light systems shall be as specified in the general specification and as specified herein.

3.3.2 System configuration. The system configuration shall consist of one specified in Table I. Switches, mating connectors and interconnecting cables shall not be furnished as components of the system.

MIL-L-85314/1A

3.3.3 Power supply.

3.3.3.1 Input power. The power supply shall conform to the general specification and shall be Type I or II, as specified (see 3.7.1 and 1.2 of the general specification).

3.3.3.2 Power consumption. Each type system shall require a maximum of 300 watts of electrical power from an aircraft source, averaged over each flash cycle.

3.3.3.3 Dimensions. The length, width and height of the power supply assembly, including mounting provisions and connectors inherent in the design of each type system, shall not exceed 14 inches for each dimension location. The total volume shall not exceed 1120 cubic inches.

3.3.3.4 Mounting. Type I and Type II power supplies shall be capable of being mounted using the hole patterns shown in Figures 5 and 6, respectively.

3.3.3.5 Interface connectors.

3.3.3.5.1 Output. The power supply shall provide interface to each light source assembly through separate D38999/40-W-D-5-S-N connectors.

3.3.3.5.2 Input.

3.3.3.5.2.1 Type I. The Type I system power supplies shall provide a D38999/40-W-D-5-P-N connector to interface input power and cockpit control signals.

3.3.3.5.2.2 Type II. The Type II system power supplies shall provide a D38999/40-W-D-5-P-W connector to interface input power and cockpit control signals.

3.3.4 Light source.

3.3.4.1 Mode. Each light source shall consist of a red light mode (low, night) and a white light mode (high, day). The red and white modes shall be remotely selectable.

3.3.4.2 Dimensions. The dimensions of each light source shall conform to Figure 3.

3.3.4.3 Mounting. Each light source shall be designed and constructed to mate with the mounting flange specified in Figure 4. The mounting flange shall not be furnished as a component of the Type I or II light system.

3.3.4.4 Flash rate for alternating light systems. Alternating light systems as specified in Table II shall emit 100 to 120 flashes per minute with each flash alternating sources in either mode shall flash $180 \pm 30^\circ$ out of phase. When either light source is deactivated, the

MIL-L-85314/1A

flash rate from the remaining single source of either mode shall be 50 to 60 flashes per minute. These flash rates shall be maintained throughout the bands of power inputs specified herein and the general specification.

3.4 Performance characteristics. The light systems shall conform to all the performance characteristic requirements specified in the general specification and as specified herein.

3.4.1 Flash rate for synchronous light systems. Synchronous light systems, as specified in Table II, shall emit synchronous flashes from both light sources of 50 to 60 flashes per minute.

3.4.2 Light intensity. The luminous intensity emitted by both the red and white modes shall have, in the vertical field, the hemispherical coverage above and below the horizontal plane of the light source specified in Table III. The minimum light intensity requirement specified in Table III, may be diminished by 15 percent for a 60 degree (maximum) sector or the 360 degree horizontal plane.

3.4.3 Electromagnetic interference. The system shall conform to the electromagnetic interference requirements of the general specification.

3.5 Weight. System configurations A and B (Figures 1 and 2) (Types I and II) shall weigh a maximum 15 pounds (6818 grams). Maximum weights are exclusive of assembly interconnecting wiring and remote switches.

NOTE: Revision letters are not used to denote changes due to the extensiveness of the changes.

Custodians:
Army - AV
Air Force - 11

Preparing Activity:
Navy - AS
(Project No. 6220-0317-2)

MIL-L-85314/1A

TABLE I. System configuration.

Applicable figure	Configuration	Quantity	
		Power supply	Light source
1	A	1	2
2	B	2	2

TABLE II. Applicable light system combinations.

System type	Config-uration	Figure	Flash rate		Quantity		Sight source
			Syn	Alternate	Power supply		
					Type I	Type II	
I	A	1	-	X	1	-	2
II	A	1	-	X	-	1	2
I	B	2	X	-	2	-	2
II	B	2	Optional		-	2	2

TABLE III. Light intensity distribution per light assembly.

Angle above (+) and below (-) horizontal plane (degrees)	Intensity (effective candelas)			
	Day mode (white)		Night mode (aviation red)	
	min	max	min	max
+80	100	-	-	-
+45	875	-	-	-
+20	1750	-	75	250
+10	2800	-	120	250
+ 5	3500	-	150	250
0	3500	-	150	250
- 5	3500	-	120	250
-10	1750	-	75	250
-20	1000	-	38	250

MIL-L-85314/1A

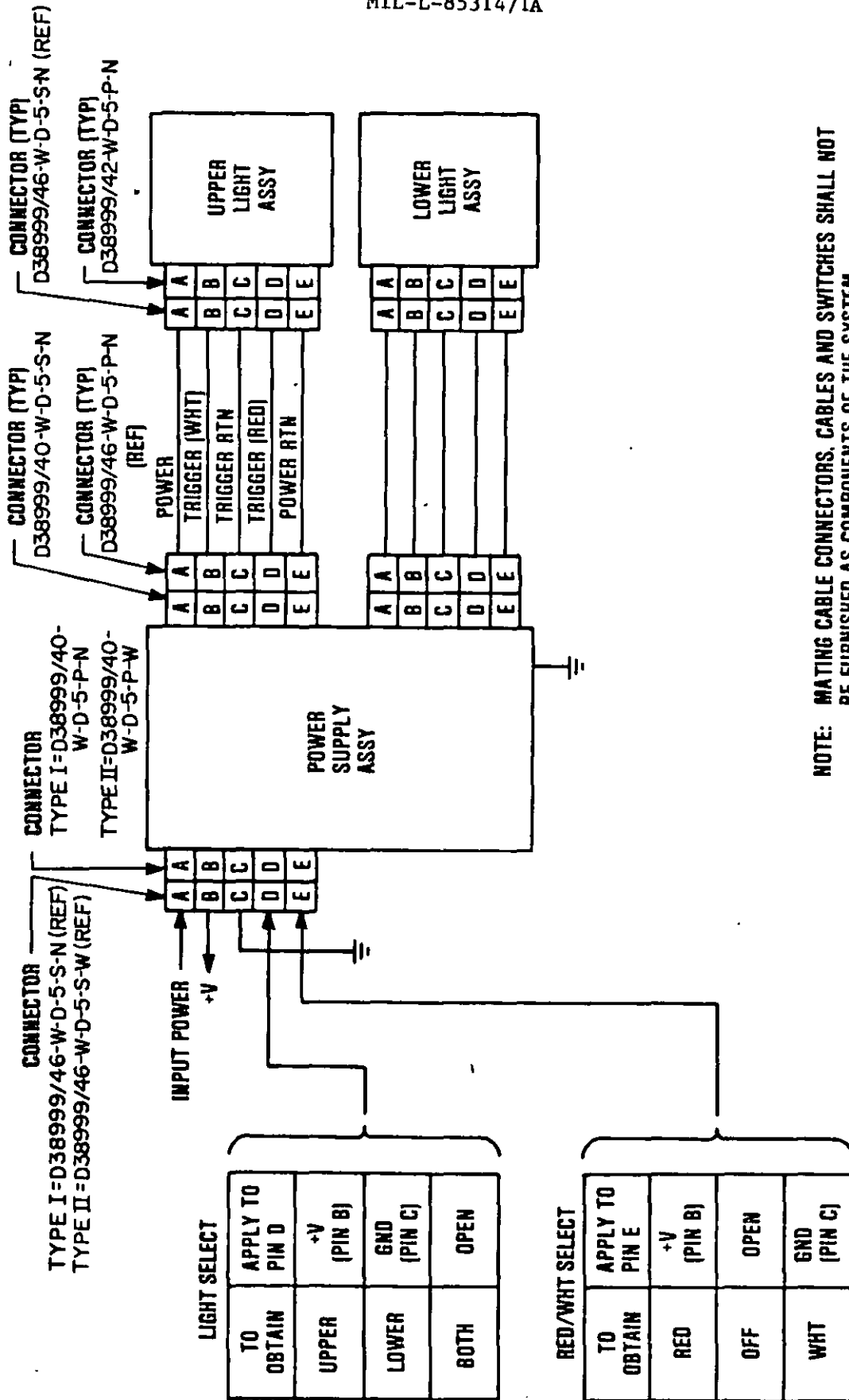
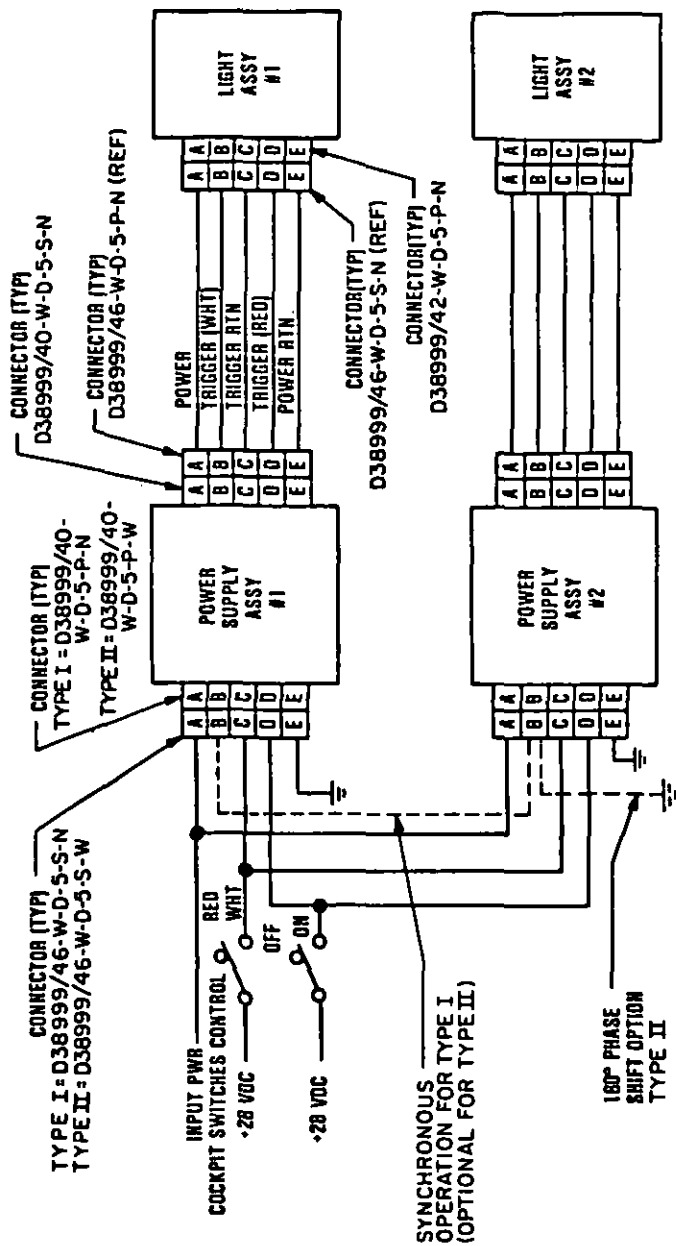

FIGURE 1. System configuration A.



NOTE: MATING CABLE CONNECTORS, CABLES AND SWITCHES SHALL NOT BE FURNISHED AS COMPONENTS OF THE SYSTEM.

FIGURE 2. System configuration B.

MIL-L-85314/1A

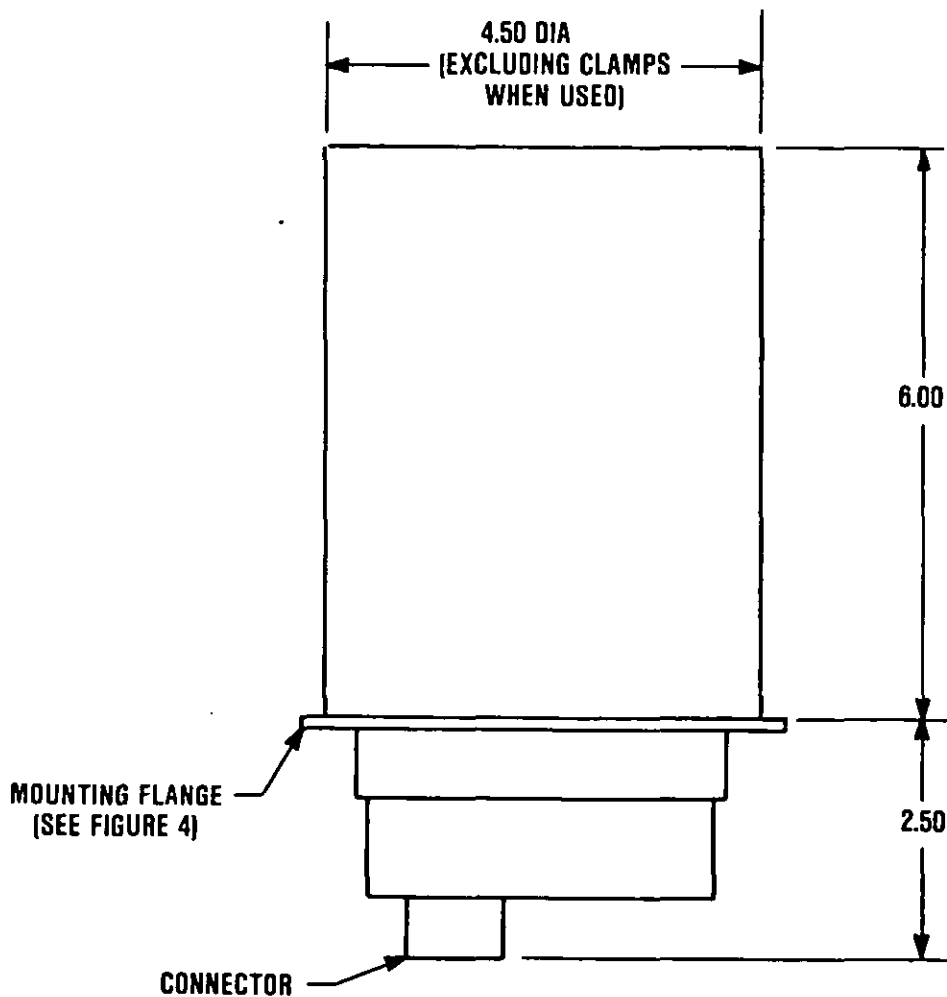

NOTES:

1. DIMENSIONS ARE IN INCHES.
TOLERANCE: .XX \pm .03
2. METRIC EQUIVALENTS ARE GIVEN FOR INFORMATION ONLY AND ARE BASED ON 1 INCH = 25.4MM
3. WEIGHT: 2.20 LBS (1.00KG)

INCHES

MM

6.00

152.40

4.50

114.30

2.50

63.50

FIGURE 3. Typical light source envelope dimensions.

MIL-L-85314/1A

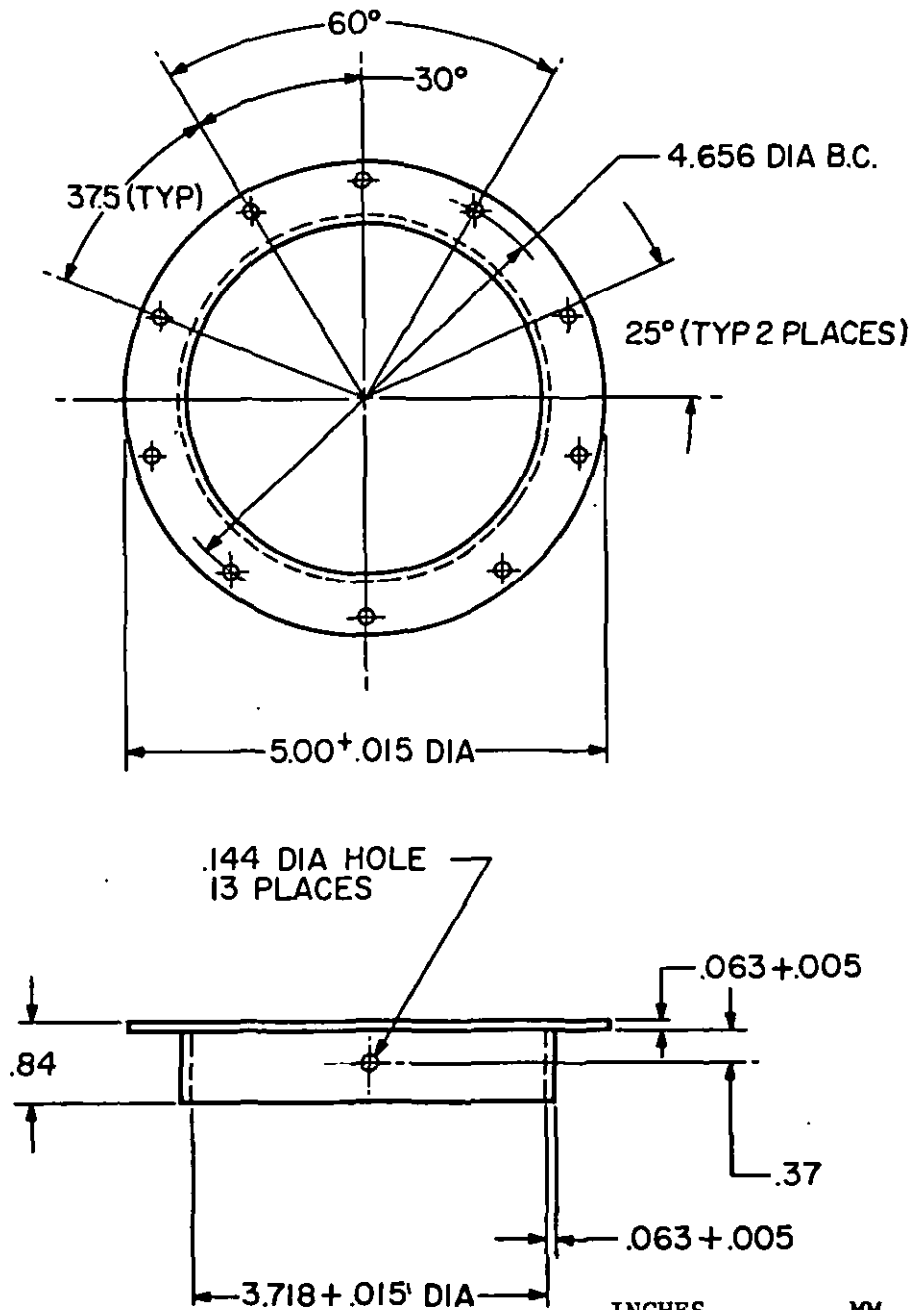

NOTES:

1. DIMENSIONS ARE IN INCHES.
TOLERANCES: .XX ± .03, .XXX ± .010
2. METRIC EQUIVALENTS ARE GIVEN FOR INFORMATION ONLY AND ARE BASED ON 1 INCH = 25.4MM.

	INCHES	MM
	5.00	127.00
	4.656	118.26
	3.718	94.44
	.84	21.34
	.37	9.40
	.144	3.66
	.063	1.60
	.015	.38
	.005	.13

FIGURE 4. Typical mounting flange dimensions and configuration.

MIL-L-85314/1A

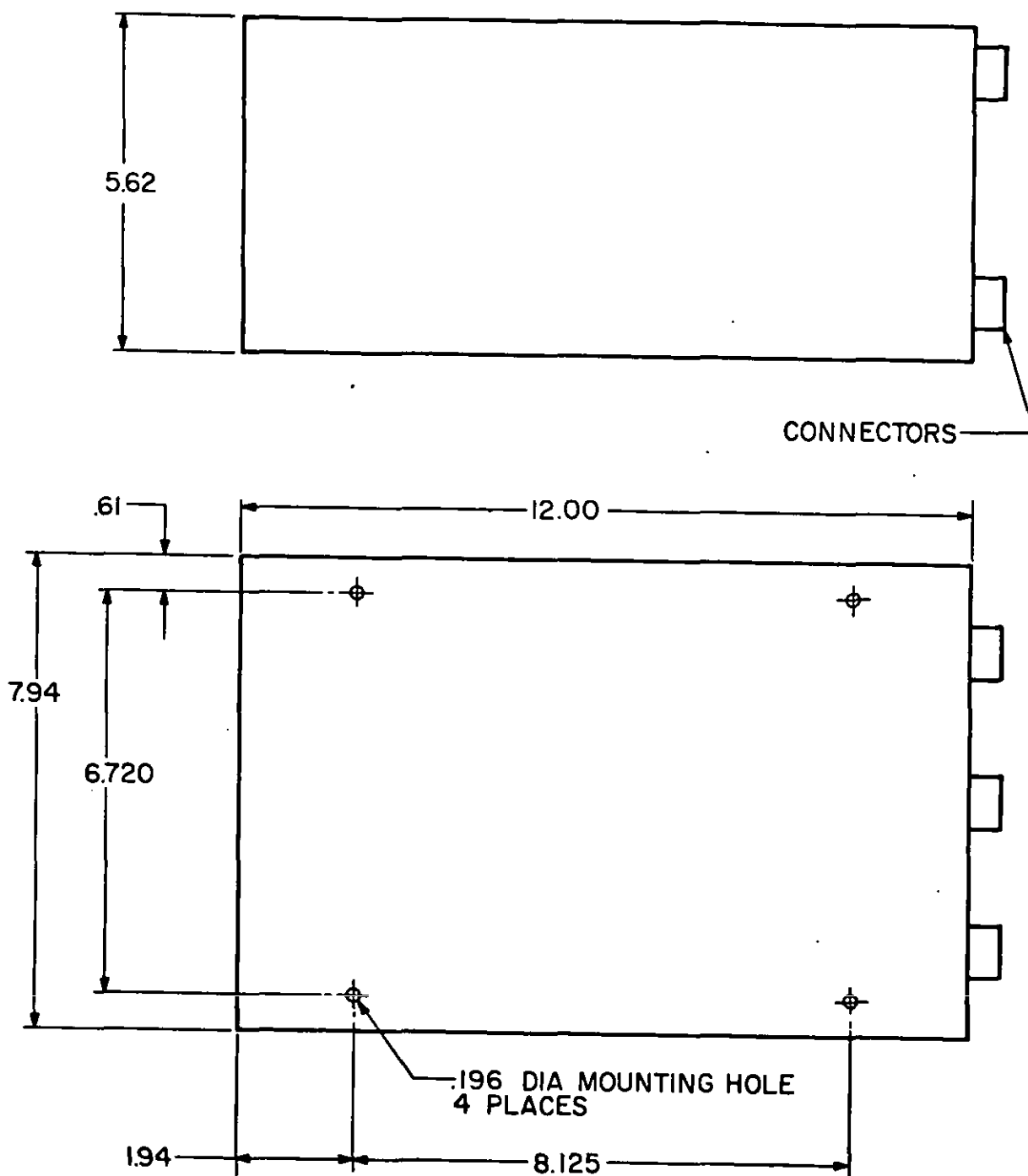

NOTES:

1. DIMENSIONS ARE IN INCHES.
TOLERANCES: $.XX \pm .03$, $.XXX \pm .010$
2. METRIC EQUIVALENTS ARE GIVEN FOR
INFORMATION ONLY AND ARE BASED ON
1 INCH = 25.4MM.

INCHES

MM

INCHES	MM
12.00	304.80
8.125	206.38
7.94	201.67
6.720	170.69
5.62	142.75
1.94	49.28
.61	15.49
.196	4.98

FIGURE 5. Typical power supply dimensions for configuration A.

MIL-L-85314/1A

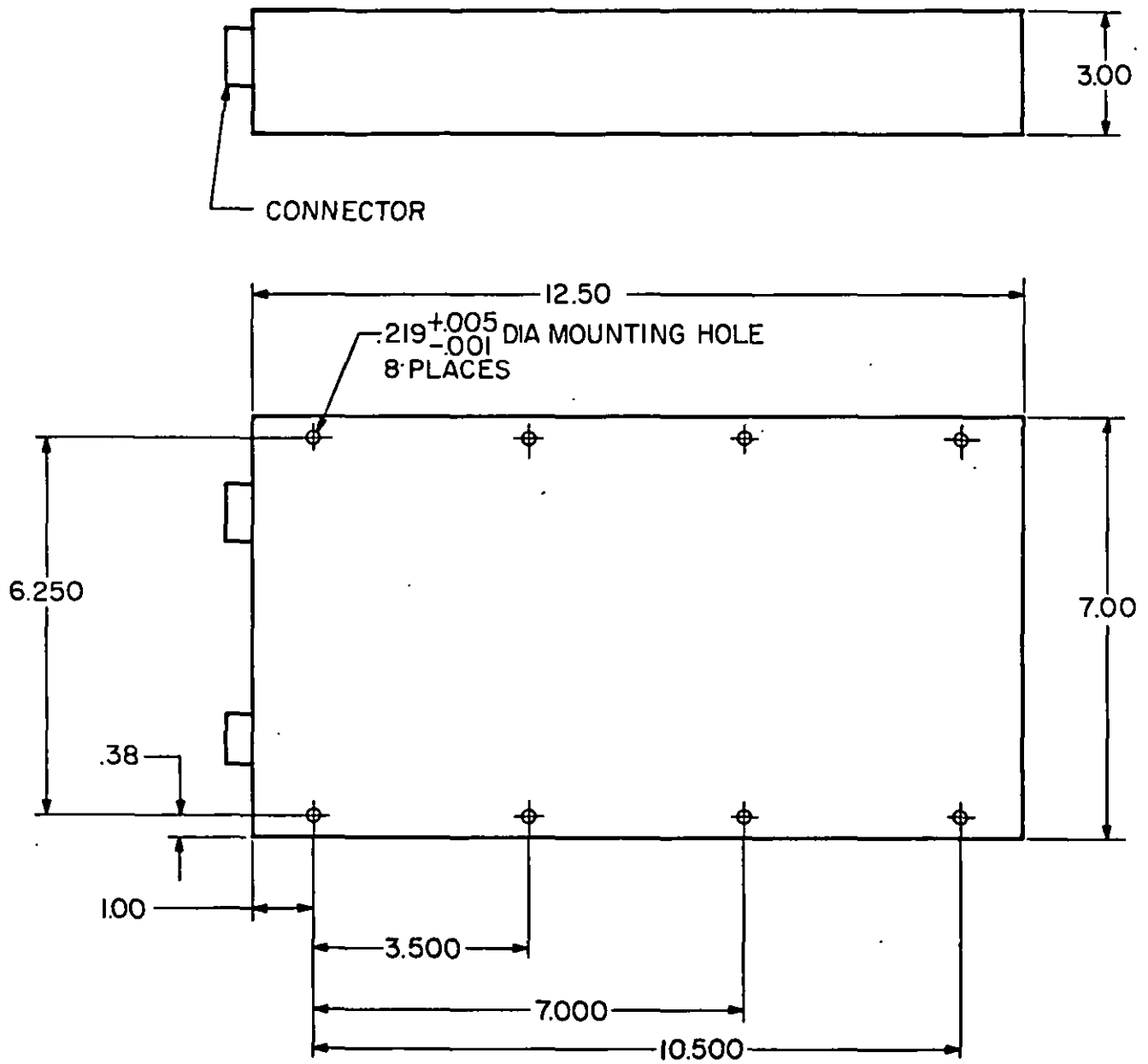

NOTES:

- DIMENSIONS ARE IN INCHES.
TOLERANCES: .XX ± .03, .XXX ± .010
- METRIC EQUIVALENTS ARE GIVEN FOR INFORMATION ONLY AND ARE BASED ON 1 INCH = 25.4MM.

INCHES

MM

INCHES	MM
12.50	317.50
10.500	266.70
7.000	177.80
6.250	158.75
3.500	88.90
3.00	76.20
1.00	25.40
.38	9.65
.219	5.56
.005	0.13
.001	0.03

FIGURE 6. Typical power supply dimensions for configuration B.