

MIL-I-6868E

8 March 1976

---

SUPERSEDING

MIL-I-6868D

30 December 1971

## MILITARY SPECIFICATION

### INSPECTION PROCESS, MAGNETIC PARTICLE

This specification is approved for use by all Departments and Agencies of the Department of Defense.

#### 1. SCOPE

1.1 Scope. This specification covers general requirements and tests for performing magnetic particle inspection.

#### 2. APPLICABLE DOCUMENTS

2.1 Issues of documents. The following documents, of the issue in effect on date of invitation for bids or request for proposal, form a part of this specification to the extent specified herein.

#### SPECIFICATIONS

##### FEDERAL

P-D-680	Dry Cleaning Solvent
VV-K-220	Kerosene, Deodorized

##### MILITARY

MIL-M-6867	Magnetic Inspection Units
MIL-I-6870	Inspection Requirements, Nondestructive, for Aircraft Materials and Parts
MIL-L-9909	Light, Ultraviolet, Metals Examining
MIL-C-45662	Calibration System Requirements

#### STANDARDS

##### MILITARY

MIL-STD-410	Nondestructive Testing Personnel Qualification and Certification
-------------	---

FSC NDTI

MIL-I-6868E

(Copies of specifications, standards, drawings, and publications required by contractors in connection with specific procurement functions should be obtained from the procuring activity or as directed by the contracting officer.)

2.2 Other publications. The following documents form a part of this specification to the extent specified herein. Unless otherwise indicated, the effect on date of invitation for bids or request for proposal shall apply:

AMERICAN SOCIETY FOR TESTING AND MATERIALS (ASTM)

ASTM D 96      Water and Sediment in Crude Oils and Fuel Oils

(Application for copies should be addressed to the American Society for Testing and Materials, 1916 Race Street, Philadelphia, Pennsylvania 19103.)

AMERICAN WELDING SOCIETY (AWS)

AWS-A.2.2      Nondestructive Testing Symbols

(Application for copies should be addressed to the Naval Publications and Forms Center (Code 1051), 5801 Tabor Avenue, Philadelphia, Pennsylvania 19120.)

(Non-Government requests should be addressed to the American Welding Society, 345 East 47th Street, New York, New York 10017.)

SOCIETY OF AUTOMOTIVE ENGINEERS AEROSPACE MATERIAL SPECIFICATIONS

AMS-2300	Premium Aircraft Quality Steel Cleanliness, Magnetic Particle Inspection Procedure
AMS-2301	Aircraft Quality Steel Cleanliness, Magnetic Particle Inspection Procedure
AMS-2303	Aircraft Quality Steel Cleanliness Martensitic Corrosion Resistant Steels, Magnetic Particle Inspection Procedure
AMS-3040	Magnetic Particle Inspection Material, Dry Method
AMS-3041	Magnetic Particles, Wet Method, Oil Vehicle
AMS-3042	Magnetic Particles, Wet Method, Dry Powder

MIL-I-6868E

AMS-3043	Magnetic Particles, Wet Method, Oil Vehicle Aerosol Canned
AMS-3044	Magnetic Particles, Flourescent, Wet Method, Dry Powder
AMS-3045	Magnetic Particles, Flourescent, Wet Method, Oil Vehicle
AMS-3046	Magnetic Particles, Flourescent, Wet Method. Oil Vehicle, Aerosol Canned

(Application for SAE publications may be obtained from the Society of Automotive Engineers, Inc., 485 Lexington Avenue, New York, NY., 10017).

(Technical society and technical association specifications and standards are generally available for reference from libraries. They are also distributed among technical groups and using Federal agencies.)

### 3. REQUIREMENTS

3.1 Responsibility for inspection. Unless otherwise specified in the contract, the contractor is responsible for the performance of all inspection requirements as specified herein. Except as otherwise specified in the contract, the contractor may use his own or any other facilities suitable for the performance of the inspection requirements specified herein, unless disapproved by the Government. The Government reserves the right to perform any of the inspections set forth in the specification where such inspections are deemed necessary to assure supplies and services conform to prescribed requirements.

3.2 Inspection of steel mill products for cleanliness. When magnetic particle inspection is specified on applicable documents, the requirements of AMS-2300, AMS-2301, or AMS-2303 may be applied. However, inspection of these materials to detect rejectable conditions, shall be in accordance with the requirements of this specification.

3.3 Inspection of fabricated parts. Component parts shall be inspected by magnetic particle as necessary to meet reliability requirements of the contract. Applicable drawings or other documents in accordance with MIL-I-6870 requirements shall specify the acceptable size, concentration, and orientation of defects in high- and low-stress areas in fabricated parts. The component drawing or applicable document shall also show:

MIL-I-6868E

- (a) Method of magnetization including magnetizing current, type, magnitude and direction.
- (b) Method of particle application.
- (c) Type of particle (dry or wet visible or wet fluorescent).
- (d) Concentration of suspension.

When the entire surface of the part is not inspected, the area of the part for inspection shall be identified in accordance with AWS-A.2.2.

3.4 Manufacturing processes. When manufacturing processes are involved which may in any way adversely affect the quality of the material or part, such as forging, heat treating, plating, cold forming, welding, grinding, straightening, machining and proof loading, inspection shall be performed subsequent to such processes. When certain processes are involved which may in any way interfere with this inspection, such as heavy deposits of chromium or nickel electroplating, the inspection shall be performed prior to and after such operations. Coating thicknesses shall not exceed 0.005 inch when magnetic particle testing for flaw detection.

3.5 Record of inspection. The results of each magnetic particle inspection shall be recorded. All recorded results shall be identified, filed, and be made available to the procuring activity, and shall be traceable to the specific part or lot inspected. Unless otherwise, specified records shall be retained for a period of two years.

3.6 Qualification of inspection personnel. All magnetic particle inspection personnel shall be qualified in accordance with MIL-STD-410.

#### 4. EQUIPMENT

4.1 Other equipment. Equipment other than that specified herein may be used, subject to approval of the procuring activity.

4.2 Cleaning. Parts and materials shall be free of all surface scale, paint, grease and other materials that would interfere with the inspection process.

MIL-I-6868E

4.3 Magnetizing apparatus. MIL-M-6867 establishes the basic requirements for magnetic particle equipment. Equipment which can fulfill the magnetizing requirements of MIL-I-6868 adequately for the configuration of the material of parts inspected and which includes the necessary requirements for safe operation is considered adequate.

4.3.1 Apparatus for circular method. Apparatus for the circular method shall be arranged to induce a magnetic flux in the piece being tested by means of low-voltage, high-amperage current passed through the piece or through a conductor which passes into or through a hole in the piece.

4.3.2 Apparatus for longitudinal method. Apparatus for the longitudinal method shall be arranged to induce a magnetic flux in the piece being tested by placing the piece in the magnetic field between the poles of electromagnets or in a coil carrying suitable current.

4.4 Lighting apparatus and intensities.

4.4.1 Visible particle techniques. The inspection area shall be equipped with white or visible light when visible particle techniques are used. A minimum of 200 foot candles of white light is required for adequate inspection. The intensities of white light shall be measured at the surface of the parts undergoing inspection.

4.4.2 Fluorescent particle techniques. Fluorescent magnetic particle inspection shall be performed in a darkened booth with a maximum ambient white light level of approximately two foot candles. The inspection area shall be equipped with black light(s) in accordance with MIL-L-9909. The intensity of the black light shall be measured at the surface of the parts being inspected, with Ultra Violet Products, Inc. Model J-221 meter or equivalent. Black light intensities shall be a minimum of  $800 \mu\text{w}/\text{cm}^2$  at 15 inches from the part surface.

4.4.3 Time interval. White light intensity measurements as specified in 4.4.1 shall be accomplished during a maximum allowable time interval of 60 days. When black lights are in use, light intensity measurements as specified in 4.4.2 shall be accomplished during a maximum time interval of one week.

MIL-I-6868E

4.5 Demagnetizing apparatus. The demagnetizing equipment shall be capable of demagnetizing all inspected parts to a satisfactory level. The level of demagnetization shall be determined with field indicators which give approximate quantitative readings of 1.5 oersteds per division. Demagnetized parts shall not produce readings exceeding 2 units or approximately 3 oersteds. More stringent requirements reflecting component utilization shall be specified on the drawing or applicable document.

## 5. PROCESSING MATERIALS

5.1 Magnetic particle materials. All magnetic particle materials utilized for inspection shall meet the requirements of AMS-3040, 3041, 3042, 3043, 3044, 3045, or 3046 (whichever is applicable for the type of particles being used).

5.2 Material performance. The magnetic materials used in the process shall be capable, when tested in accordance with 7.1.2, of detecting at least the outer holes in the sensitivity ring (Figure 2) as defined by the Table below. The material shall produce suitable contrast for the intended application and shall be nontoxic.

TABLE I. Ring specimen indications.

Type of Suspension	Amperage	Minimum Number of Holes Indicated
Nonflourescent, wet	1400	3
	2500	5
	3400	6
Dry Powder	1400	4
	2500	6
	3400	7
Fluorescent	1400	3
	2500	5
	3400	6

MIL-I-6868E

5.1.1 Liquid. The liquid used as a vehicle for carrying the magnetic substance for the wet process shall be a light oil, such as kerosene, conforming to VV-K-220, a dry cleaning solvent, conforming to P-D-680, or an equivalent acceptable to the procuring activity. When approved by the procuring activity, water with an inhibitor and a wetting agent may be used as a liquid vehicle. Although virtually all oil vehicles or water conditioned with wetting agents having a slight blue fluorescence, liquid vehicles for fluorescent magnetic particles shall be essentially non-fluorescent. The use of water baths on cadmium plated steels with tensile strength above 180 ksi is prohibited.

#### 5.2.2 Suspensions.

5.2.2.1 Visible particle concentrations. When tested in accordance with 7.2.1.1, the volume of visible magnetic particles shall be 1.0 to 2.4 ml., unless otherwise specified.

5.2.2.2 Fluorescent particle concentrations. When tested in accordance with 7.2.1.1, the volume of fluorescent magnetic particles shall be 0.1 to 0.5 ml, unless otherwise specified.

5.2.2.3 Viscosity. Total addition of all material to the liquid vehicle shall not raise the viscosity of the suspension above a maximum of 5.0 centistokes at any temperature at which the bath may be used.

5.2.2.4 Suspensions containing both fluorescent and visible magnetic substances shall not be used.

5.3 Dry Process. The magnetic powders used in the dry process shall be capable, when tested in accordance with 7.1.2, of detecting at least the outer holes in the sensitivity ring (Figure 2) as defined by Table I. (See comments on Paragraph 5.1). The powder shall produce suitable contrast for the intended application and shall be nontoxic.

### 6. PROCEDURE

6.1 Cleaning before test. The surface of all materials and parts shall be free from grease, oil, rust, scale, or other matter which might interfere with the proper distribution and concentration, or with intensity, character, or definition of the deposit of the magnetic substance. All small openings leading to internal passages or cavities shall be plugged. Plugging materials shall not mask edges of openings. Note: In the event that a material such as a

MIL-I-6868E

lubricant or antiseize compound is removed which is required for functional or other reasons, the same material(s) shall be reapplied in accordance with the applicable engineering drawing or specifications. Paint and other coatings shall be removed unless otherwise specified by the procuring activity.

6.2 Masking. When the possibility exists that the suspension may damage certain components of the part, as, for example, certain non-metallics, effective masking, including faying surfaces, shall be used to prevent contact with the suspension.

6.3 Circular magnetization.

6.3.1 A central conductor of as large a diameter as practical shall be used in all cases where inspections of the inside surfaces of cylindrically shaped parts is required. A central conductor shall also be used for circular magnetization of other shapes, when applicable. Keep the central conductor against one side of the part as shown in Figure 1. The distance along the circumference effectively magnetized is approximately four times the diameter of the central conductor. When the entire circumference is not magnetized at one time, inspect the entire circumference by repositioning the cylinder on the conductor allowing for approximately 10 percent magnetic field overlap.

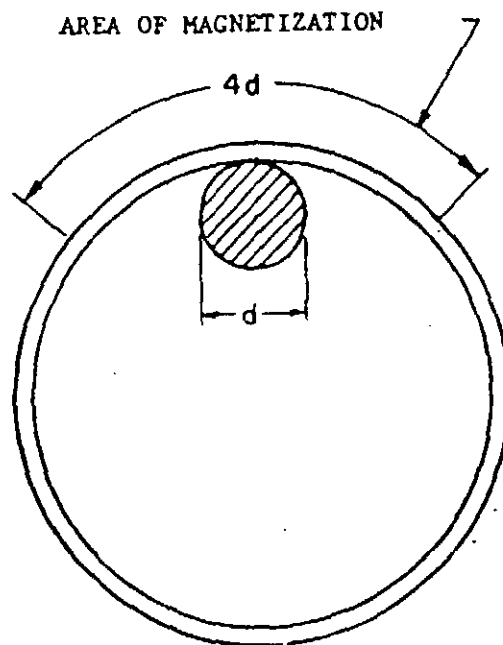

FIGURE 1. Circular magnetization.



MIL-I-6868E

6.3.2 Where it is necessary to pass current through the part itself, care shall be exercised to prevent burning at the electrode contact areas. All contact areas shall be clean, parts shall be mounted between contact plates, and suitable pressure exerted to insure electrical contact. Use of copper braided pads between the electrodes and the part is recommended. When practical, large and heavy parts shall be mounted in suitable fixtures to insure proper orientation.

6.3.3 Magnetizing currents applied by "head shots" shall be a minimum of 1000 amperes per square inch of cross sectional area. Magnetizing currents through the central conductor shall be a minimum of 1.5 times that required if the part itself was placed between the heads.

6.3.4 Unless otherwise specified in the purchase order or contract, flexible cables shall not be used to induce circular magnetization because of the difficulty of orienting the cable parallel to the part.

6.3.5 Contact prods shall not be used on aerospace components.

6.3.6 Spring loaded contact clamps shall not conduct more than 800 amperes when clamped directly on the part.

#### 6.4 Longitudinal magnetization.

6.4.1 When parts are being magnetized by use of a coil, they shall be positioned within the coil and as close to the side of the coil as possible.

6.4.1.1 When using a coil, and the part is positioned on the bottom inside of the coil, the current to be used in the inspection shall be calculated from the following equation:

$$I = \frac{K}{(N)(1/D)} \quad \text{where}$$

I = coil current to be used, amps,

N = number of turns in the coil,

L = part length, inches. For parts longer than 18 inches, L shall be assigned a maximum value of 18 inches.

MIL-I-6868E

D = part diameter, inches, and

K = constant (45,000)

6.4.1.2 The following table gives typical coil currents for a five turn coil:

TABLE II. Typical coil shot currents (amperes) for a five turn coil.

(L) PART LENGTH IN INCHES	(D) PART DIAMETER IN INCHES	L/D RATIO	AMPERE-TURNS REQUIRED	AMPERES REQUIRED
8	4	2	22,500	4,500
12	3	4	11,250	2,250
12	2	6	7,500	1,500
16	2	8	5,625	1,125
10	1	10	4,500	900
18	1-1/2	12	3,750	750
14	1	14	3,214	643

6.4.2 To insure complete inspection, successive over lapping shots shall be used on parts that are longer than the coil axis length plus 12 inches (6 inches on each end of coil.)

6.4.3 Three to five turns shall be employed for hand held coils formed with cable.

6.5 Magnetic flux density. Flux density may be measured for the development of inspection techniques for high stress areas. The flux density and direction may be measured on the surface of the part if the instrumentation used is rendered insensitive to magnetic fields in air.

6.6 Application of particles.

6.6.1 Wet process. For other than squeeze bottles or aerosol cans circulate the suspension for at least 15 minutes before beginning

MIL-I-6868E

inspection. For the continuous method, the suspension shall be applied to the pieces by hosing or immersion so that all surfaces to be examined are thoroughly covered. For the residual method, the suspension shall be applied by immersion. In residual immersion applications, parts shall be removed carefully from the suspension to avoid washing off the indications.

6.6.1.1 Continuous method. The magnetizing circuit shall be closed just before the suspension is diverted from the part. A minimum of two shots of magnetizing current, each 1/2 to 1 second in duration shall be applied.

6.6.1.2 Wet residual method. The part shall be magnetized by the application of 2 shots of current, each at least 1/2 second long. After the current has been turned off, the suspension shall be applied, either by hosing or by immersion in the suspension. The residual method shall be used only when specified by the procuring activity. When alternating current is authorized, the current shall not be employed with the residual method unless the source of the magnetization current is equipped with a suitably synchronized, timed instrument, adjusted to prevent the opening of the magnetic circuit, except during the second quadrant ( $90^{\circ}$  to  $180^{\circ}$  phase angle) of the current wave form.

6.6.2 Dry process (not for use on aerospace components without the specific approval of the procuring activity.) The powder shall be sprayed or dusted directly on the area to be inspected and excess powder removed. A more uniform distribution of the powder may be obtained by lightly vibrating the part. Care shall be exercised in avoiding excessive use of powder because such use will interfere with effective evaluation of defects. Care shall be used in removing excess powder to avoid distributing indications present. For the continuous method, the magnetizing circuit shall be closed just before application of powder and shall remain closed during any subsequent blowing, tapping or vibrating. For the residual method, the piece shall be magnetized, after which the magnetizing current shall be turned off and the powder applied as described above.

6.6.3 The wet continuous process shall be used when inspecting for discontinuities on the surface and just below the surface, such as nonmetallic inclusions found in all rolled steel products and in forgings,

MIL-I-6868E

and tight shallow defects such as grinding or fatigue cracks, which afford a minimum of magnetic flux leakage.

## 6.7 Inspection

6.7.1 Detection of discontinuities. Magnetic particle inspection shall be performed in such manner as to assure satisfactory detection of harmful discontinuities having axes in any direction. A complete magnetic particle inspection test shall consist of multiple magnetizing and inspection operations so conducted that the magnetic lines of force will be transverse, insofar as is practical, to any discontinuity that may be in the piece. Special viewing aids: mirrors, boroscopes, high intensity lamps, etc. will be used for viewing interior areas of parts not readily accessible for normal viewing by inspector.

6.7.2 Irrelevant indications. Particles will adhere to certain local areas created by such design factors as keyways, drilled holes, and abrupt changes of section. Operators shall be acquainted with these and other irrelevant indications arising from these changes in geometry and shall be able to recognize them in an inspection.

6.7.3 Removal of discontinuities. Discontinuity indications in excess of the specified magnetic particle quality level will be reported. If it is established that such discontinuities will not be removed by subsequent machining operations or other suitable mechanical removal techniques, the parts shall be rejected. Dimensions and tolerances on applicable drawings or other publications shall be referred to in all cases. All parts which have had discontinuities removed by machining shall be reinspected to assure defect removal.

6.8 Demagnetization. Demagnetize parts or material between successive magnetizing operations whenever the residual magnetism interferes with the interpretation of indications. In addition, demagnetize all parts and material after completion of magnetic particle inspections. Perform demagnetization as follows:

6.8.1 When using an AC demagnetizing coil, hold the part about one foot in front of the coil and then move it slowly and steadily through the coil and at least three feet beyond the end of the unit. Repeat this process several times if the part does not readily lose its residual magnetism. Rotate and tumble parts of complex configuration while passing through the field of the coil.

MIL-I-6868E

6.8.2 When a 30 point automatic reversing DC demagnetizing unit is used, demagnetize the part in the same position as it was magnetized. The reversing DC cycle should be repeated until the residual magnetic field is depleted.

6.8.3 After demagnetization, test parts with a magnetic field indicator at several locations. Test parts of complex configuration at all significant changes in geometry. Demagnetized parts shall not produce deflections exceeding 2 units or about 3 oersteds on the field indicator after all demagnetization.

6.9 Cleaning after demagnetization. The magnetic substance shall be completely removed from all parts after inspection and demagnetization. Care shall be taken to thoroughly remove all plugs in holes and cavities.

6.10 Marking. Parts which have met the magnetic particle inspection requirements shall be marked in accordance with the applicable drawing, specification, purchase order, contract, or as specified herein. Marking, as specified herein, shall be applied in such manner and location as to be harmless to the part and so as to preclude removal, smearing, or obliteration by subsequent handling. When subsequent processing which would remove identification is planned, the applicable paragraph 6.10.5 symbol shall be affixed to the record accompanying the parts.

6.10.1 Etching. Unless otherwise specified, parts shall be marked by etching, employing fluids and application methods that are not detrimental to the part as a whole. Care must be taken to prevent any potential part damage resulting from the etch fluid.

6.10.2 Impression stamping. Impression stamping may be used where permitted by the applicable specifications or drawings. Impressions should be located in areas adjacent to the part number, whenever practicable.

6.10.2.1 Weld beads. Impression stamping shall not be used on weld beads since this practice can cause stress risers in weldments which may result in fatigue failure.

6.10.3 Dyeing. Where etching or impression stamping is not appropriate, identification may be by dyeing the entire part, or using a rubber stamp with dye.

MIL-I-6868E

6.10.4 Other means of identification, such as tagging, may be applied to parts such as completely ground and polished balls, rollers, pins, and bushings; for which the construction, finish, or functional requirements preclude the use of etching, stamping, or dyeing.

6.10.4.1 Bolts and nuts may be identified as having met the requirements of magnetic particle inspection by conspicuously marking each package.

6.10.5 Symbols for inspected parts. When specified, each item which has been inspected and accepted shall be marked as follows:

- (a) When stamping, etching, or dyeing is applicable, the symbol M shall be employed, either by itself or in a circle or an ellipse. In addition, the symbol shall also identify the facility doing the Magnetic Particle inspection.
- (b) When dyeing is applicable, green dye shall be employed.
- (c) When tagging or labeling is applicable, a statement that the parts conform to the magnetic particle inspection requirements shall be included on the tag or label.

## 7. QUALITY CONTROL

7.1 Equipment and procedures. The effectiveness of equipment and procedures established by the prime contractor to be used by his company and his sub-contractors in performing magnetic particle inspection on a given part or types or parts shall be checked at intervals established by the prime contractor. Such check shall be made by utilizing a simulated part containing fabricated defects, a part or parts in which defects have been found by previous magnetic particle inspection, or the Ketos tool steel ring as described in 7.1.2. The above test shall not be used to indicate the concentration of the suspension.

### 7.1.1 Equipment output.

MIL-I-6868E

7.1.1.1 Stationary machines. Pulse length timers shall be set for 1/2 to 1 second unless specified otherwise. Machine ammeter readings and calibration readings, as determined with a calibrated ammeter/shunt combination, shall be made at intervals as specified in MIL-C-45662 to insure continued accuracy of the equipment. Results shall be recorded. Variations exceeding  $\pm 10$  percent shall necessitate repair or replacement.

7.1.1.2 Yokes. AC electromagnetic yokes shall have a dead weight lifting power of at least 10 pounds with a spacing of 3 to 6 inches. DC electromagnetic or permanent magnetic yokes shall have a dead weight lifting power of at least 30 pounds with a 2 to 4 inch spread or 40 pounds with a 4 to 6 inch spread.

7.1.2 System effectiveness. The general effectiveness of DC magnetic particle inspection shall be checked at intervals not exceeding 1 week by examination of a steel ring with known discontinuities as shown in Figure 2. The ring shall be fabricated from AISI O1 Ketos tool steel with Rockwell B hardness between 90 and 95. The process shall be evaluated by use of the wet continuous method with circular magnetization applied by using the amperage listed in Table I through a one-inch diameter central conductor. The minimum number of holes required to be visible on the outer edge of the ring is as indicated in Table I.

## 7.2 Suspension.

7.2.1 Concentration test. The suspension as delivered on the part shall be tested for magnetic substance content by the following method at 8 hour intervals or shorter intervals if specified by the prime contractor. The method of test shall be as follows:

- (a) Run the pump for at least 30 minutes.
- (b) Fill a 100-ml graduated centrifuge tube as specified in ASTM D-96, to the 100-ml mark with suspension directly from the hose or other device used for applying it to the part in an inspection, or from an immersion tank. Demagnetize the suspension if considered necessary and let it stand for 30 minutes to precipitate or until the solid matter is apparently all down.

MIL-I-6868E

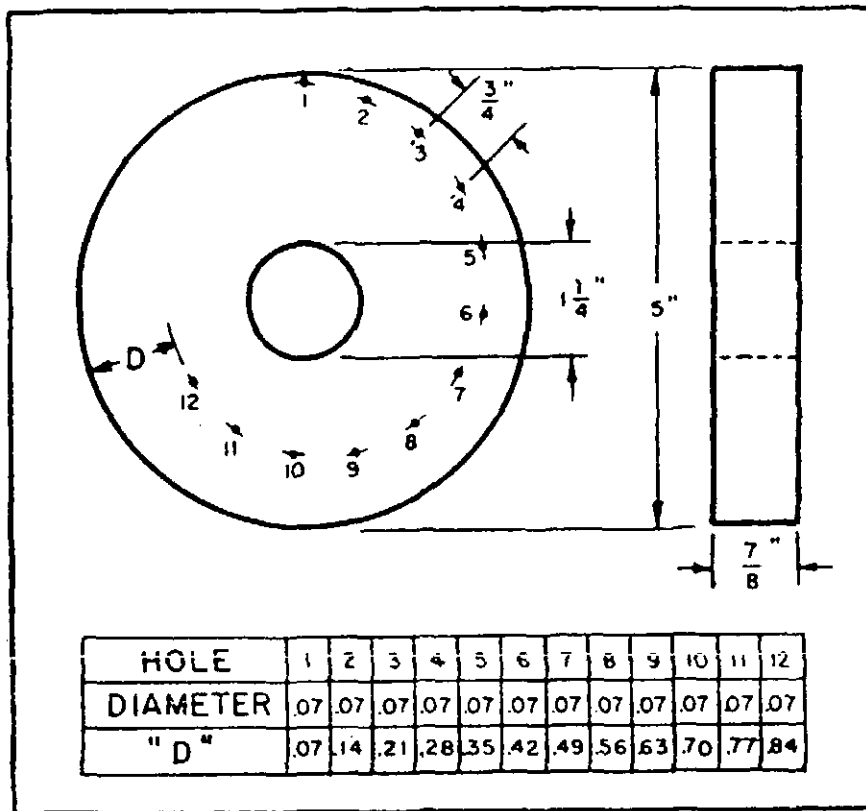

FIGURE 2. Ring specimen with artificial sub-surface discontinuities.

- (c) Read the volume of the precipitate in the graduate. The volume shall be in accordance with 5.1.2. Results shall be recorded.

**7.2.2 Contamination test.** Each 30 days or at a shorter interval if specified by the procuring activity, the suspension shall be tested for contamination as follows:

- (a) Perform steps (a) and (b) of 7.2.1.



MIL-I-6868E

- (b) Examine the liquid above the precipitate with black light. The liquid shall not fluoresce.
- (c) Examine the precipitate. If two distinct layers can be seen, read the volume of each layer. The top layer volume (contamination) shall not exceed 50 percent of the bottom layer volume (magnetic particles) nor shall it fluoresce.

7.2.3 Test for water suspension. Tests shall be made by "water break" or other means approved by the procuring activity to insure the presence of sufficient wetting agent in the water suspension. The water break test shall be performed by flooding a part, similar in surface finish to those under test, with suspension, and then noting the appearance of the surface of the part after the flooding is stopped. If the film of suspension is continuous and even all over the part, sufficient wetting agent is present. If the film of suspension breaks, exposing bare surfaces of the part, and the suspension forms many separate droplets on the surface, more wetting agent is needed. In general, more wetting agent will be required to wet smooth surfaces than rough surfaces. Whenever possible, non-ionic wetting agent should be used. However, in all cases, the amount of wetting agent added should be limited so as not to raise the alkalinity of the suspension above a pH of 9.2.

## 8. DEFINITION OF TERMS

8.1 Circular magnetization. The circular method consists of inducing a circular magnetic field in the piece such that the magnetic lines of force (in any one plane normal to the axis of the current) take the form of concentric rings about the axis of the current. This is accomplished by passing the current directly through the piece or through a conductor which passes into or through a hole in the piece. The circular method is applicable for the detection of defects with axes approximately parallel or radial to the axis of the current through the piece.

8.2 Longitudinal magnetization. The longitudinal method consists of inducing a magnetic field into the piece such that the magnetic lines of force extending through the piece are approximately parallel to the axis of the magnetizing coil, or to a line connecting the two poles when electromagnets are used, and tend to follow the contour of the piece. This method is applicable for detection of defects with axes approximately transverse to the axis of the coil or to a line connecting the two points

MIL-I-6868E

of application of the electromagnets.

8.3 Continuous method. The continuous method of examination consists of applying, or otherwise making available on the surface of the piece, an ample amount of magnetic substance to form satisfactory indications while the magnetizing current is being applied.

8.4 Residual method. In the residual method of examination, the magnetic substance is applied to the piece after it has been magnetized and the magnetizing current is off.

8.5 Black light. Black light is the term popularly applied to the invisible radiant energy in that portion of the ultraviolet spectrum just beyond the blue of the visible spectrum. It is the range between 3,200 and 4,000 angstrom units in wavelength, (predominantly 3650 angstrom units).

8.6 Fluorescence. Fluorescence is a term used to describe the effect produced by certain chemical products which exhibit the property of emitting visible light during activation by black light. These materials absorb the invisible energy, alter its wavelength, and emit the energy in the form of light which is visible to the eye.

8.7 Indication. An indication is an accumulation of magnetic particles being held by a magnetic leakage at the surface of a part when magnetic particle inspection is applied. The indication may be caused by a discontinuity (an actual void or break in the metal) or it may be caused by some other condition that produces a leakage field.

8.8 Magnetic flux. The lines of force in a magnetic circuit always form from closed loops or paths; a magnetic circuit is always closed. The total number of magnetic lines existing in a magnetic circuit is called magnetic flux. Its unit is a single line force called the Maxwell, usually designated by the Greek letter Phi.

8.9 Flux density. This is the flux-per-unit area through an element which cuts the unit area at right angles to the direction of the flux. Flux density, or induction, is usually designated by the letter B and its unit is the gauss.

MIL-I-6868E

8.10 Permeability. The ease with which a magnetic flux is established in a given material. Permeability is numerically equal to  $B/H$  or the ratio of flux density to magnetizing force. A material which has high permeability has low reluctance and vice versa.

8.11 Reluctance. Reluctance is the opposition of a magnetic material to the establishment of magnetic flux. The reluctance of the material determines the magnitude of the flux produced by a given magnetic force. Reluctance is analogous to the resistance in an electric circuit.

8.12 Magnetizing force. This is the total force tending to set up a magnetic flux by a magnetizing current. It is usually designated by the letter  $H$  and its unit is the oersted.

8.13 Hysteresis loop. The hysteresis loop (curve) is a plot of flux density ( $B$  - measured in gauss) versus magnetizing force ( $H$  - measured in oersteds). The test specimen used to plot this curve is a piece of unmagnetized steel. (See Figure 3.)

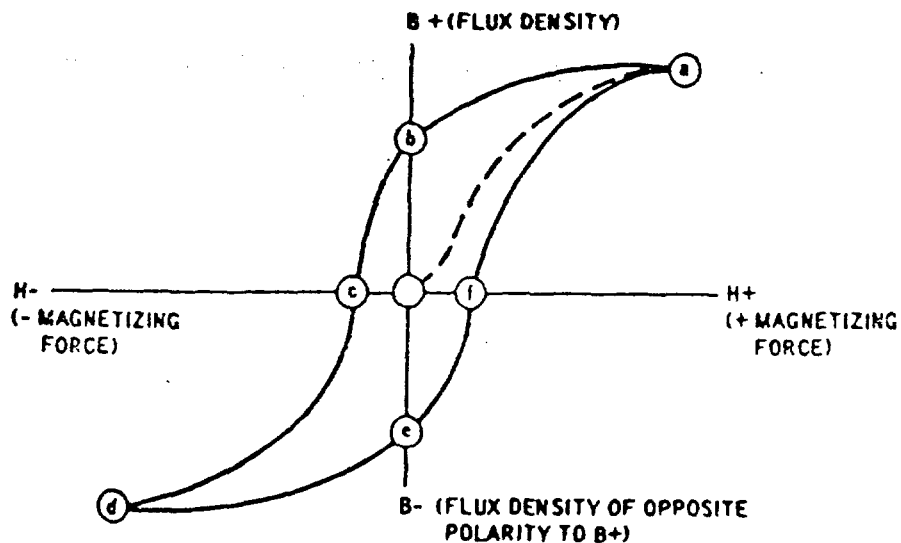

FIGURE 3. The hysteresis curve.

MIL-1-6868E

NOTES:

- (o) - This point on the hysteresis loop represents the unmagnetized state of a piece of steel.
- (a) - This point on the hysteresis loop represents the saturation point, a point at which an increase in the magnetizing force produces no more flux (field).
- (b) - This point on the hysteresis loop represents the residual field, that is the remaining magnetism in the part after the magnetizing force is removed.
- (c) - This point on the hysteresis loop represents coercive force, that is the reverse magnetizing force necessary to bring the flux density back to zero if a part is magnetized.
- (d) - This point on the hysteresis loop represents the negative (-) saturation point.
- (e) - This point on the hysteresis loop represents the negative (-) residual field.
- (f) - This point on the hysteresis loop represents a point opposite, and equal to, (c) (coercive force).

8.14 Residual Magnetism. Residual magnetism is the amount of magnetism which a magnetic material retains after the magnetizing force is removed.

8.15 Retentivity. The retentivity of a particular magnetic material is its property to retain a greater or lesser degree of residual magnetism.

8.16 Coercive Force. Coercive force is defined as the reverse magnetizing force necessary to remove the residual magnetism so as to demagnetize a specimen.

8.17 Magnetic Materials. Some materials are attracted by a magnet while others are repelled. From the definition of magnetism it follows that magnetic materials are those which are attracted by magnetism. These materials are known as paramagnetic materials, whereas materials

MIL-I-6868E

which repel are known as diamagnetic materials. In the realm of magnetic particle testing, the subdivision of paramagnetic, also called ferromagnetic; is a main concern, as only ferromagnetic materials can be strongly magnetized.

8.18 Discontinuity. An interruption in the normal physical structure or configuration of a part. A discontinuity may or may not affect the usefulness of a part.

## 9. NOTES

9.1 Intended use. This specification is intended to complement specifications for magnetic inspection of materials or parts and is applicable only when referenced by the specific material or item specification. The inspection process covered is intended for the detection of surface or sub-surface discontinuities in magnetic materials.

### Custodians:

Army - MR  
Navy - AS  
Air Force - 11

### Preparing activity

Air Force - 11

Project No. NDTI-0017

### User activity:

Army - ME, WC, AT, MU  
Navy - OS

**INSTRUCTIONS:** In a continuing effort to make our standardization documents better, the DoD provides this form for use in submitting comments and suggestions for improvements. All users of military standardization documents are invited to provide suggestions. This form may be detached, folded along the lines indicated, taped along the loose edge (*DO NOT STAPLE*), and mailed. In block 5, be as specific as possible about particular problem areas such as wording which required interpretation, was too rigid, restrictive, loose, ambiguous, or was incompatible, and give proposed wording changes which would alleviate the problems. Enter in block 6 any remarks not related to a specific paragraph of the document. If block 7 is filled out, an acknowledgement will be mailed to you within 30 days to let you know that your comments were received and are being considered.

**NOTE:** This form may not be used to request copies of documents, nor to request waivers, deviations, or clarification of specification requirements on current contracts. Comments submitted on this form do not constitute or imply authorization to waive any portion of the referenced document(s) or to amend contractual requirements.

(Fold along this line)

(Fold along this line)

DEPARTMENT OF THE AIR FORCE



NO POSTAGE  
NECESSARY  
IF MAILED  
IN THE  
UNITED STATES

**OFFICIAL BUSINESS**  
PENALTY FOR PRIVATE USE \$300

**BUSINESS REPLY MAIL**  
FIRST CLASS PERMIT NO. 73236 WASHINGTON D C

POSTAGE WILL BE PAID BY THE DEPARTMENT OF THE AIR FORCE

ASD/ENESS  
Wright-Patterson AFB, OH 45433

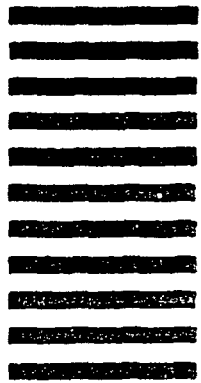

## STANDARDIZATION DOCUMENT IMPROVEMENT PROPOSAL

*(See Instructions - Reverse Side)*

1. DOCUMENT NUMBER	2. DOCUMENT TITLE
3a. NAME OF SUBMITTING ORGANIZATION	4. TYPE OF ORGANIZATION <i>(Mark one)</i> <input type="checkbox"/> VENDOR  <input type="checkbox"/> USER  <input type="checkbox"/> MANUFACTURER  <input type="checkbox"/> OTHER <i>(Specify):</i> _____
b. ADDRESS <i>(Street, City, State, ZIP Code)</i>	
5. PROBLEM AREAS	
a. Paragraph Number and Wording:	
b. Recommended Wording:	
c. Reason/Rationale for Recommendation:	
6. REMARKS	
7a. NAME OF SUBMITTER <i>(Last, First, MI) - Optional</i>	b. WORK TELEPHONE NUMBER <i>(Include Area Code) - Optional</i>
c. MAILING ADDRESS <i>(Street, City, State, ZIP Code) - Optional</i>	8. DATE OF SUBMISSION <i>(YYMMDD)</i>