

MIL-H-62217/2(AT)
 12 September 1974

MILITARY SPECIFICATION SHEET

HOSE, PREFORMED, SILICONE, POLYESTER REINFORCED
 (RADIATOR)

The complete requirements for procuring the hose described herein shall consist of this document and the issue in effect of MIL-H-62217.

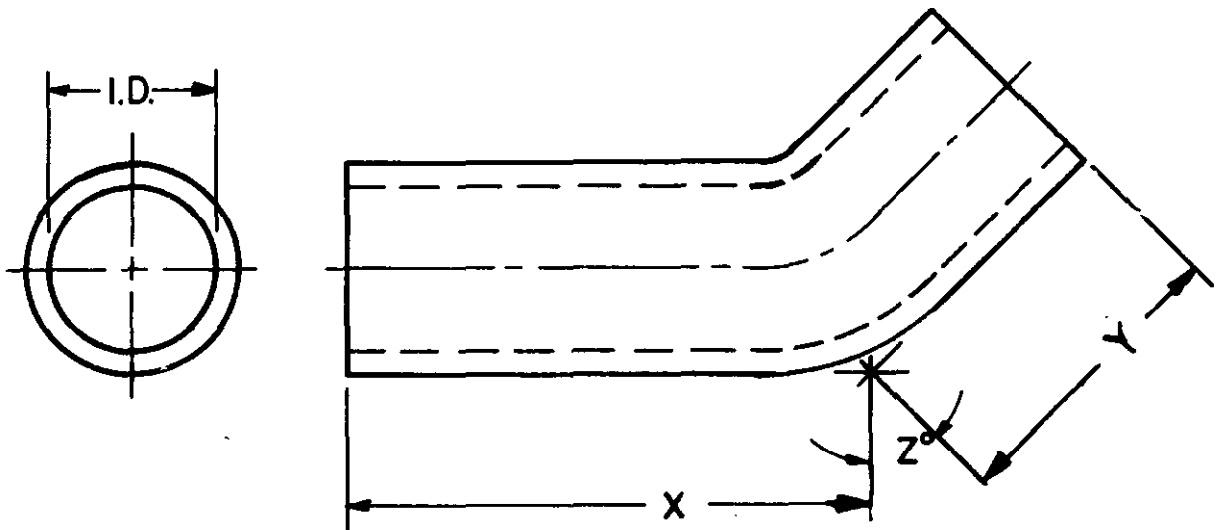

TABLE I

INSIDE DIAMETERS							
A	B	C	D	E	F	G	H
1-1/4	1-1/2	1/3/4	2	2-1/4	2-1/2	3	4

FSC-4720

MIL-H-62217/2(AT)

TABLE II

PART NO. INDEX CODE	LENGTH IN INCHES	PART NO. INDEX CODE	LENGTH IN INCHES
A	5	J	14
B	6	K	16
C	7	L	18
D	8	M	20
E	9	N	22
F	10	P	24
G	11	R	26
H	12	S	28

TABLE III

DEGREE OF BEND					
A	B	C	D	E	F
15	30	45	60	75	90

NOTES:

1. Type II, hose, preformed, silicone, polyester reinforced, of Specification MIL-H-62217.
2. Dimensions shown are in inches or degrees as applicable.
3. Part number definition: (See Tables I, II and III).

MIL-H-62217/2(AT)

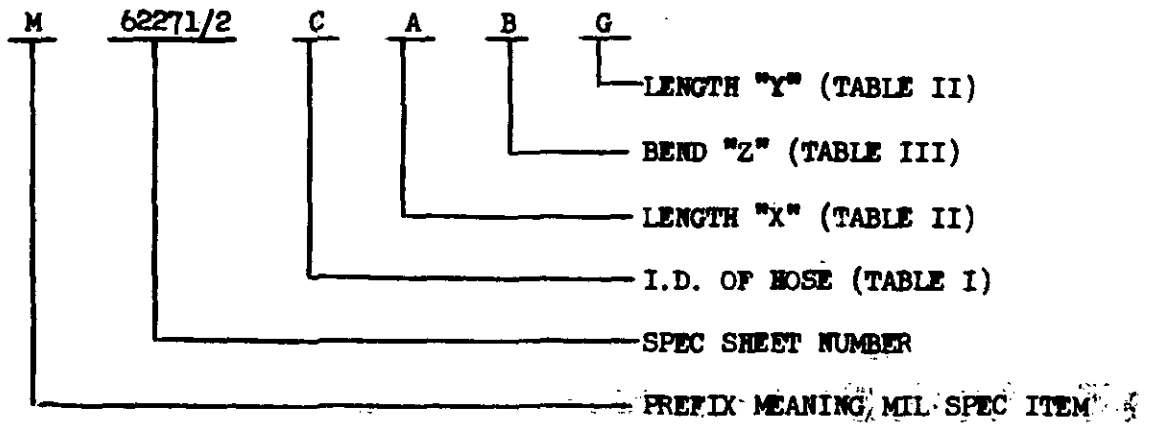

Custodians:
Army - AT

Preparing activity:
Army - AT

Project No. 4720-A381

STANDARDIZATION DOCUMENT IMPROVEMENT PROPOSAL		OMB Approval No. 22-R255
<p>INSTRUCTIONS: The purpose of this form is to solicit beneficial comments which will help achieve procurement of suitable products at reasonable cost and minimum delay, or will otherwise enhance use of the document. DoD contractors, government activities, or manufacturers/vendors who are prospective suppliers of the product are invited to submit comments to the government. Fold on lines on reverse side, staple in corner, and send to preparing activity. Comments submitted on this form do not constitute or imply authorization to waive any portion of the referenced document(s) or to amend contractual requirements. Attach any pertinent data which may be of use in improving this document. If there are additional papers, attach to form and place both in an envelope addressed to preparing activity.</p>		
DOCUMENT IDENTIFIER AND TITLE		
NAME OF ORGANIZATION AND ADDRESS		CONTRACT NUMBER
		MATERIAL PROCURED UNDER A <input type="checkbox"/> DIRECT GOVERNMENT CONTRACT <input type="checkbox"/> SUBCONTRACT
<p>1. HAS ANY PART OF THE DOCUMENT CREATED PROBLEMS OR REQUIRED INTERPRETATION IN PROCUREMENT USE?</p> <p>A. GIVE PARAGRAPH NUMBER AND WORDING.</p> <p>B. RECOMMENDATIONS FOR CORRECTING THE DEFICIENCIES</p>		
2. COMMENTS ON ANY DOCUMENT REQUIREMENT CONSIDERED TOO RIGID		
<p>3. IS THE DOCUMENT RESTRICTIVE?</p> <p><input type="checkbox"/> YES <input type="checkbox"/> NO (If "Yes", in what way?)</p>		
4. REMARKS		
SUBMITTED BY (Printed or typed name and address - Optional)		TELEPHONE NO.
		DATE

DD FORM 1426
1 JAN 72

REPLACES EDITION OF 1 JAN 66 WHICH MAY BE USED

C 16061

FOLD

POSTAGE AND FEES PAID



OFFICIAL BUSINESS
PENALTY FOR PRIVATE USE \$300

Commander
US Army Tank Automotive Command
ATTN: AMSTA-RSE
Warren, MI 48090

FOLD