

MIL-H-11996B

~~23 October 1980~~

SUPERSEDING

MIL-H-11996A (Sig C)

5 May 1960

MILITARY SPECIFICATION
HANDSETS
GENERAL SPECIFICATION FOR

This specification is approved for use by all Departments and Agencies of the Department of Defense.

1. SCOPE

1.1 Scope. This specification covers three types of handsets designated as handset H-60()/U, handset H-156()/U, and handset H-165()/U. Transmitter element TA-117, telephone receiver TA-235()/PT and switch assembly SA-129()/PT are part of the above handsets. Electrical cord assembly CX-2151()/U is part of handset H-60()/PT. Cord CX-4533()/U is part of handset H-165()/PT. A cord assembly constructed as specified herein is part of handset H-156()/PT.

2. APPLICABLE DOCUMENTS

2.1 Issues of documents. The following documents of the issue in effect on date of invitation for bids or request for proposal, form a part of this specification to the extent specified herein.

SPECIFICATIONS

FEDERAL

FF-S-92	- Screw, Machine: Slotted, Cross-Recessed or Hexagon Head.
NN-P-71	- Pallets, Material Handling, Wood, Stringer Construction, 2-Way and 4-way (Partial).
QQ-B-613	- Brass, Leaded and Nonleaded. Flat Products (Plate, Bar, Sheet, and Strip).
QQ-B-626	- Brass, Leaded and Nonleaded. Rod, Shapes, (Forgings, and Flat Products with Finished Edges (Bar and Strip)).
QQ-C-533	- Copper-Beryllium Alloy Strip (Copper Alloy Numbers 170 and 172).
QQ-C-585	- Copper-Nickel-Zinc Alloy Plate, Sheet, Strip, and Bar (Copper Alloy Numbers 735, 745, 752, 762, 766, and 770).
QQ-S-571	- Solder, Tin Alloy: Tin-Lead Alloy, and Lead Alloy.
QQ-S-763	- Steel Bars, Wire, Shapes, and Forgings, Corrosion-Resisting.
QQ-S-766	- Steel Plates, Sheets, and Strip-Corrosion Resisting.
QQ-S-781	- Strapping, Steel, and Seals.
PPP-B-585	- Boxes, Wood, Wirebound.
PPP-B-601	- Boxes, Wood, Cleated-Plywood.
PPP-B-621	- Boxes, Wood, Mailed and Lock-Corner.
PPP-B-636	- Boxes, Shipping, Fiberboard.
PPP-T-60	- Tape: Packaging, Waterproof.
PPP-T-76	- Tape, Packaging, Paper (For Carton Sealing).

Beneficial comments (recommendations, additions, deletions) and any pertinent data which may be of use in improving this document should be addressed to: Commander, US Army Communications, Research and Development Command, ATTN: DRSEL-MMD-P, Fort Monmouth, New Jersey 07703 by using the self-addressed Standardization Document Improvement Proposal (DD Form 1426) appearing at the end of this document or by letter.

MIL-H-11996B

SPECIFICATIONS

MILITARY

- MIL-C-50 - Copper Alloy, Number 260 Cartridge Brass, 70 Percent, Sheet Strip, Plate bar, and Discs.
- MIL-W-76 - Wire and Cable, Hookup, Electrical, Insulated.
- MIL-P-116 - Preservation-Packaging, Methods of.
- MIL-T-152 - Treatment, Moisture and Fungus-Resistant, of Communications, Electronic, and Associated Electrical Equipment.
- MIL-V-173 - Varnish, Moisture-and-Fungus Resistant (For Treatment of Communications, Electronic, and Associated Equipment).
- MIL-I-631 - Insulation, Electrical, Synthetic-Resin Composition, Nonrigid.
- MIL-C-2069 - Cloth, Fleece, Cotton Wrap and Wool-Nylon Filling, Lining, 15-Ounce, Shrink Resistant.
- MIL-R-3065 - Rubber, Fabricated Products.
- MIL-W-3795 - Wire, Electrical (Tinsel).
- MIL-C-3849 - Cord, Electrical (Tinsel).
- MIL-C-3885 - Cable Assemblies and Cord Assemblies, Electrical (Power, Control, and Audio-Frequency); General Specification for.
- MIL-I-3930 - Insulating and Jacketing Compounds, Electrical (For Cables, Cords, and Wires).
- MIL-I-4997 - Insulating and Jacketing Compounds for use in Cords, Cordages, and Cables.
- MIL-S-6872 - Soldering Process, General Specification for.
- MIL-S-8660 - Silicone Compound.
- MIL-T-10727 - Tin Plating; Electrodeposited or Hot-Dipped, For Ferrous and Nonferrous Metals.
- MIL-G-10944 - Gage, Dimensional Control.
- MIL-G-13451 - Gages, Dimensional Control, Mechanical (For USAECOM).
- MIL-C-13924 - Coating, Oxide, Black, For Ferrous Metals.
- MIL-F-14072 - Finishes for Ground Electronic Equipment.
- MIL-C-45662 - Calibration System Requirements.

STANDARDS

MILITARY

- MIL-STD-105 - Sampling Procedures and Tables for Inspection by Attributes.
- MIL-STD-129 - Marking for Shipment and Storage.
- MIL-STD-147 - Palletized Unit Loads.
- MIL-STD-202 - Test Methods for Electronic and Electrical Component Parts.
- MIL-STD-454 - Standard General Requirements for Electronic Equipment.
- MIL-STD-794 - Parts and Equipment, Procedures for Packaging and Packing of.
- MIL-STD-810 - Environmental Test Methods.
- MIL-STD-1188 - Commercial Packaging of Supplies and Equipment.
- MIL-STD-1285 - Marking of Electrical and Electronics Parts.
- MS35274 - Screw, Machine-Drilled Fillister Head, Slotted, Brass, Black Chemical Finish, UNF-2A.

DRAWINGS

DEPARTMENT OF NAVY

- SK-N-864 - Simulated Gun Blast Production Equipment.

MIL-H-11996B

DEPARTMENT OF ARMY

DL-SM-B-207906 - Handset H-60()/U.
 SC-D-55381 - Handle, Handset Assembly.
 SC-D-76454 - Handset H-156/U (Assembly).
 SC-D-76457 - Cord Assembly for Handset H-156()/U.
 SC-DL-19832 - Cord Assembly Electrical CX-2151()/U.
 SC-DL-55379 - Handset H-156()/U.
 SC-DL-76453 - Handset H 156()/U.
 SC-DL-207960 - Switch Assembly SA-129/PT.
 SM-C-207940 - Crystal Unit, Rectifying.
 SM-D-207907 - Handset H-60/PT (Assembly).

(Copies of specifications, standards, drawings, and publications required by contractors in connection with specific procurement functions should be obtained from the procuring activity or as directed by the contracting officer.)

2.2 Other publications. The following documents form a part of this specification to the extent specified herein. Unless otherwise indicated, the issue in effect on date of invitation for bids or request for proposal shall apply.

AMERICAN NATIONAL STANDARDS INSTITUTE (ANSI)

S3.7-1973(R1971) - Coupler Calibration of Earphones, Method for.
 S1.10-1966 - Calibration of Microphones, Method for.

(Application for copies should be addressed to the American National Standards Institute, 1430 Broadway, New York, NY 10018.)

WESTERN ELECTRIC COMPANY

BO-256514 - Artificial Mouth

(Application for copies should be addressed to Western Electric Company, 717 Dexter Avenue, Seattle, Washington, 98104.)

(Technical society and technical association specification and standards are generally available for reference from libraries. They are also distributed among technical groups and using Federal agencies.)

3. REQUIREMENTS

3.1 Specification sheets. The individual item requirements shall be as specified herein and in accordance with the applicable specification sheets. In the event of any conflict between requirements of this specification and the specification sheets, the latter shall govern (see 6.2).

3.2 First article. When specified, (see 6.3) the contractor shall furnish sample unit(s) for first article inspection and approval (see 4.5 and 6.3).

3.3 Materials. Materials shall be as specified in table I of 4.3.

3.4 Design and construction.

3.4.1 Click reducer. A suitable click reducer as specified in SM-C-207940 or equal, shall be used with either the receiver element or the receiver circuit to limit the maximum acoustic output of the receiver, and to guard against possible damage to the receiver element caused by high transient voltages.

3.4.2 Connections. Soldering leads, lugs, and terminals shall be tinned, silver-plated, or lead-alloy coated. Wires subject to breakage at the connections shall be provided with terminals that grip the wire insulation. Solderless terminals may be used on tinned, standard wire in power or audio circuits, but other wire connections shall be soldered. Where practicable, wire soldered to terminals shall be looped at least once and not more than twice around the terminals before soldering, or equivalent means shall be employed. Textile insulation ends of wires shall be secured against fraying by mechanical means or by application of varnish conforming to MIL-V-173.

MIL-H-11996B

3.4.3 Cord, cordage, and cord assembly. The cord and cordage shall conform to SC-DL-19832, and SC-D-76457, as specified (see 3.1). The cord assembly shall conform to MIL-I-4997, when specified (see 3.1).

3.4.4 Gage. Gages shall conform to MIL-G-10944 or MIL-G-13451.

3.4.5 Plugs. The plugs shall be as specified (see 3.1).

3.4.6 Screws. Screws shall conform to FF-S-92 or MS35274.

3.4.7 S-hook assembly (when applicable). The S-hook assembly shall conform to the specified drawing (see 3.1).

3.4.8 Soldering. Soldering process shall conform to MIL-S-6872.

3.4.9 Switch assembly. The switch assembly SA-129()/PT shall be constructed in accordance with SC-DL-207960 (see 3.1).

3.4.10 Transmitter element. The transmitter element TA-117()/PT shall be constructed in accordance with figure 2.

3.4.11 Receiver element. The receiver element TA-235()/PT shall be constructed in accordance with figure 1.

3.4.12 Dimensions and configurations. The dimensions and configurations of these handsets shall be in accordance with the appropriate figures (see 3.1) and DL-SM-B-207906, SC-DL-76453, and SC-DL-55379, as specified (see 3.1).

3.4.13 Handset assemblies. Handset assemblies shall be in accordance with SM-D-207907, SC-D-76454, and SC-C-55381, as specified (see 3.1).

3.5 Receiver. The receiver shall meet the following requirements when tested.

3.5.1 Sensitivity. When tested as specified in 4.7.2.1, the receiver output shall be 74 \pm 3 dB above 20 dynes per sq. cm. at 1,000 Hz.

3.5.2 Frequency response. When tested as specified in 4.7.2.2, the frequency response of the receiver shall be within the following limits:

Frequency range Hz	Deviation - dB (from the 1 kHz level)
500 - 1300	+3 -3
1300 - 3200	+5 -5

3.5.3 Impedance. When tested as specified in 4.7.2.3, the impedance of each receiver element at 1 kHz shall be 150 \pm 15 Ω .

3.5.4 Overload. When tested as specified in 4.7.2.4, the receiver shall show no evidence of rattling or distortion.

3.5.5 Magnetic stability. When tested as specified in 4.7.2.5, the frequency response degradation of each element shall not exceed \pm 2 dB, from levels specified in 3.5.2.

3.5.6 Dielectric strength and leakage resistance. When tested as specified in 4.7.2.6, the receiver element shall show no signs of breakdown or decrease of the insulation resistance below 1 megohm between the case and the terminals.

3.6 Transmitter. The transmitter shall meet the following requirements when tested.

3.6.1 Sensitivity. When tested as specified in 4.7.3.1, the transmitter output shall not be less than 46 dB above a zero reference level of .001 volt.

MIL-H-11996B

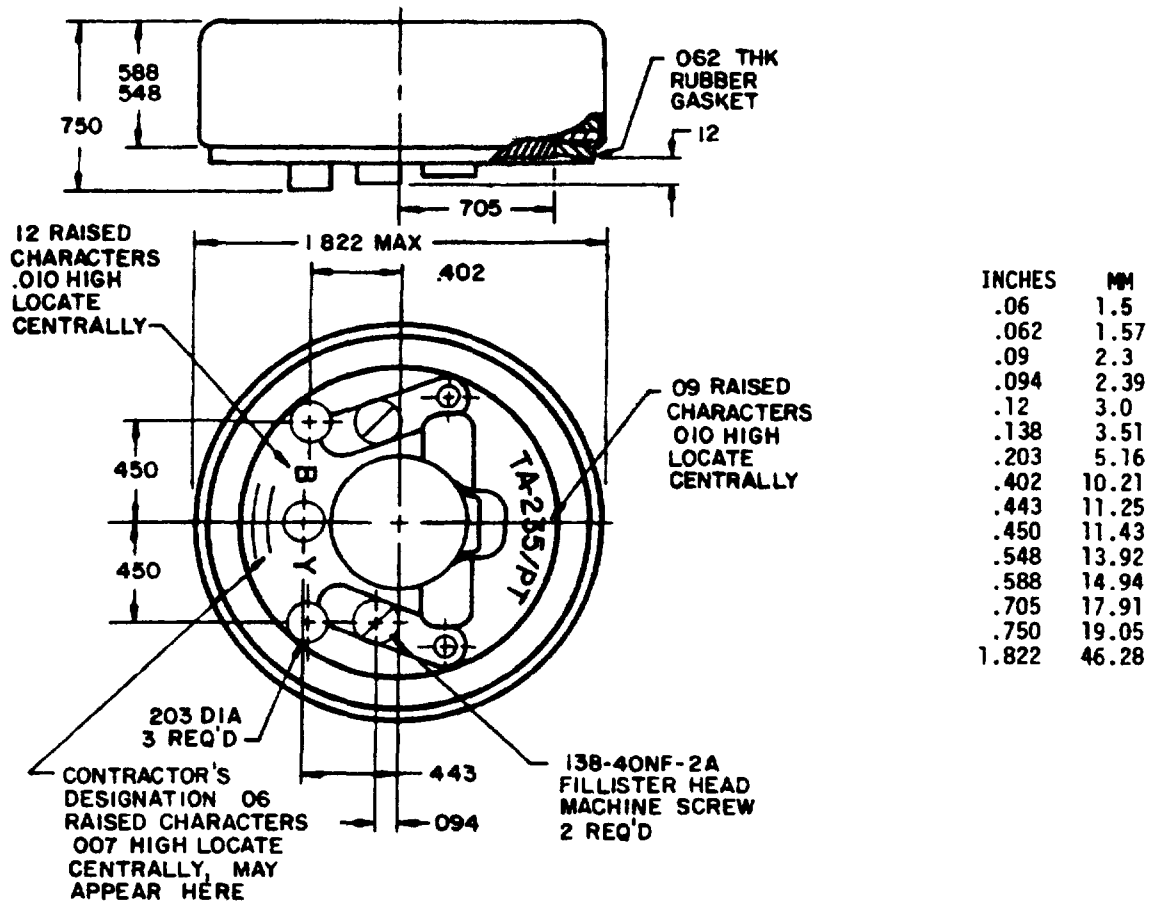

NOTES:

1. Dimensions are in inches.
2. Metric equivalents are given for general information only and are based upon 1.00 inch = 25.4 mm.
3. Unless otherwise specified, tolerances are ± 0.005 (.13 mm) for three place decimals and ± 0.02 (.5 mm) for two place decimals.

FIGURE 1. Receiver element.

MIL-H-11996B

INCHES	MM
.02	.5
.06	1.5
.12	3.0
.203	5.16
.268	6.81
.293	7.44
.405	10.29
.563	14.30
.584	14.83
1.054	26.77
1.814	46.08

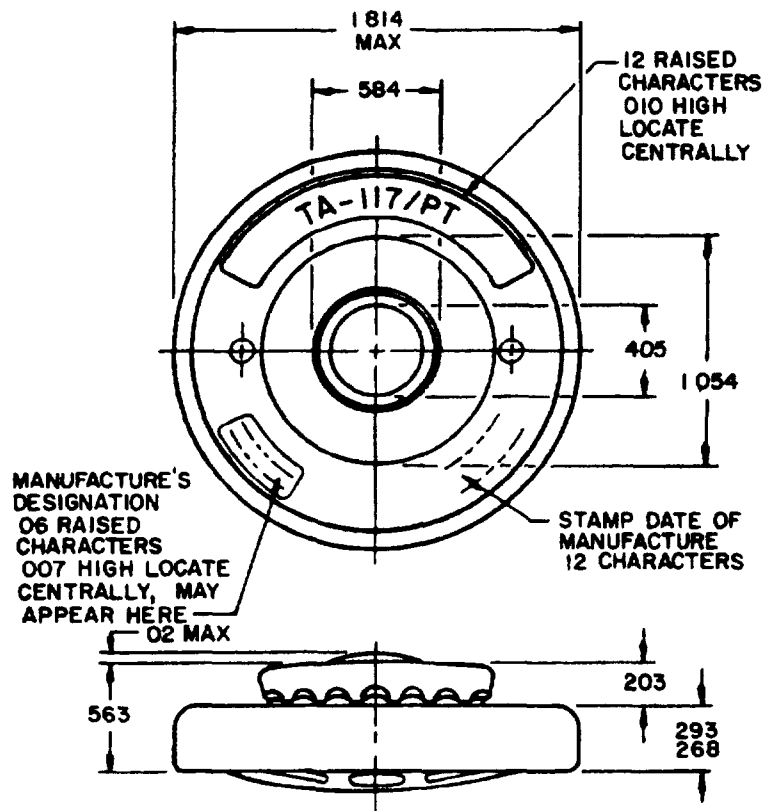

NOTES:

1. Dimensions are in inches.
2. Metric equivalents are given for general information only and are based upon 1.00 inch = 25.4 mm.
3. Unless otherwise specified, tolerances are ± 0.005 (.13 mm) for three place decimals and ± 0.02 (.5 mm) for two place decimals.

FIGURE 2 Transmitter element

MIL-H-11996B

3.6.2 Frequency response.

- a. When tested in a vertical position as specified in 4.7.3.2, the frequency response of the transmitter shall follow a trend line that rises between the limits of 300 Hz to 3,000 Hz at the approximate rate of 2 dB per octave and intersects the level specified in 3.6.1. The rate of change in response shall not exceed the following limits:

<u>Frequency range (in Hz)</u>	<u>Rate of change</u>
300 - 600	5 dB per 100 Hz
600 - 1,000	5 dB per 200 Hz
1,000 - 3,000	5 dB per 250 Hz

- b. When tested in positions other than vertical, the variation in frequency response shall not exceed the following limits:

<u>Position</u>	<u>Deviation from vertical response</u>	
40° face up	+5 dB	-5 dB
90° face up	+7 dB	-7 dB
90° face down	+9 dB	-7 dB

3.6.3 Frequency band response. When tested as specified in 4.7.3.3, the transmitter frequency response shall be not less than 52 dB above .001 volt across the 600 Ω load. The measured values shall be corrected to compensate for transformer loss.

3.6.4 Resistance. When tested as specified in 4.7.3.4, the resistance of each transmitter shall be 35 \pm 10 Ω in the unaged state.

3.6.5 Unagitated current. When tested as specified in 4.7.3.5, the unagitated current shall not exceed 125 milliamperes.

3.6.6 Thermal voltage. When tested as specified in 4.7.3.6, the maximum allowable thermal voltage on individual unagitated transmitter elements at any angle of the transmitter diaphragm relative to vertical shall be 7.0×10^{-3} volts.

3.7 Operational (talk). When handsets are tested as specified in 4.7.4, there shall be no buzzing, rattling, or other spurious sounds. The transmission shall be an intelligible signal.

3.8 Vibration. When handsets are tested as specified in 4.7.5, there shall be no evidence of physical or electrical defects. Following the test, the frequency response shall not exceed ± 2 dB from the limits specified in 3.5.2 and ± 4 dB from the limits specified in 3.6.2.

3.9 Immersion. When handsets are tested as specified in 4.7.6, there shall be no evidence of physical or electrical defects. Following the test, after removing the excess water from the handset by shaking, the frequency response shall not exceed ± 2 dB from the limits specified in 3.5.2 and 3.6.2.

3.10 Shock (drop). When handsets are tested as specified in 4.7.7, there shall be no evidence of physical or electrical defects, except minor chipping. Following the test, the frequency response shall not exceed ± 2 dB from the limits specified in 3.5.2 and ± 4 dB from the limits specified in 3.6.2.

3.11 Thermal shock. When handsets are tested as specified in 4.7.8, there shall be no evidence of physical or electrical defects. Following the test, the frequency response shall not exceed ± 2 dB from the limits specified in 3.5.2 and 3.6.2.

3.12 Tumbling. When handsets are tested as specified in 4.7.9, there shall be no evidence of physical or electrical defects except contact scars. Following the test, the frequency response shall not exceed ± 2 dB from the limits specified in 3.5.2 and ± 4 dB from the limits specified in 3.6.2.

3.13 Relative humidity. When handsets are tested as specified in 4.7.10, there shall be no evidence of physical or electrical defects. Following the test, the frequency response shall not exceed ± 2 dB from the limits specified in 3.5.2 and ± 4 dB from the limits specified in 3.6.2.

MIL-H-11996B

3.14 Gundlast resistance. When handsets are tested as specified in 4.7.11, there shall be no evidence of physical or electrical defects. Following the test, the frequency response shall not exceed ± 2 dB from the limits specified in 3.5.2 and ± 4 dB from the limits specified in 3.6.2.

3.15 Switches (when applicable). When handsets are tested as specified in 4.7.12, there shall be no evidence of physical damage, electrical defects, or degradation in performance. The force to operate the switch shall be 3 pounds maximum, and the force to hold the switch in the operate position shall be 2 pounds maximum.

3.16 Interchangeability. Corresponding units and replaceable assemblies, subassemblies, and replaceable parts shall be physically and functionally interchangeable as units without modification thereof or of other articles the items are used with. When dimensions, ratings, characteristics, etc., are not specified, the manufacturer's design limits shall be used to determine compliance. When a dimension is not within specified or design limits, it shall be considered a major defect. The following shall be examined:

- a. External and internal dimensions of insertable assemblies, when such dimensions affect mating of parts.
- b. Dimensions of cavities, when such dimensions affect insertion of items.
- c. Size and form of special threads.

3.17 Marking. Handsets shall be marked in accordance with MIL-STD-1285, with the type number and the manufacturer's name or symbol, and as specified (see 3.1).

3.18 Workmanship. Handsets shall be processed in such a manner as to be uniform in quality and shall be free from loose or deposited foreign materials, and other defects that will affect life serviceability, or appearance.

4. QUALITY ASSURANCE PROVISIONS

4.1 Responsibility for inspection. Unless otherwise specified in the contract, the contractor is responsible for the performance of all inspection requirements as specified herein. Except as otherwise specified in the contract, the contractor may use his own or any other facilities suitable for the performance of the inspection requirements specified herein, unless disapproved by the Government. The Government reserves the right to perform any of the inspections set forth in the specification where such inspections are deemed necessary to assure supplies and services conform to prescribed requirements.

4.1.1 Test equipment and inspection facilities. Test and measuring equipment and inspection facilities of sufficient accuracy, quality and quantity to permit performance of the required inspection shall be established and maintained by the contractor. The establishment and maintenance of a calibration system to control the accuracy of the measuring and test equipment shall be in accordance with MIL-C-45662.

4.1.1.1 Test equipment.

- a. Vacuum tube voltmeter. A Ballantine model 300 vacuum tube voltmeter or equal shall be used having a flat frequency response from at least 10 Hz to 10,000 Hz and capable of measuring voltages from .001 volts rms to 10 volts or more.
- b. Sound source. A Western Electric Company artificial mouth per drawing 60-256514 or equal sound source shall be used.
- c. Audio oscillator. A general radio type 1304-B beat frequency oscillator or equal having a wave form distortion of less than 2 percent shall be used.
- d. Band frequency oscillator. An oscillator shall be used that will generate a band frequency sweeping at a linear rate from 600 Hz to 1,500 Hz to 600 Hz 12 times per second.
- e. Condenser microphone. A Western Electric 640AA condenser microphone or equal, with its protective grid, shall be used for measuring sound pressures. It shall be calibrated by the reciprocity method in accordance with S1.10-1966.

MIL-H-11996B

4.1.1.2 Test apparatus. The transmitter element assembled in its housing shall be mounted coaxially with the sound source and with a 1/4 inch air space between the guard ring on the sound source and the cap of the transmitter housing as determined with a flat, 1/4 inch thick guage that is wider than the cap diameter. The housing shall be acoustically and mechanically equivalent to the transmitter end of the handset H-60/PT, including the cap of the handset. The test apparatus shall provide mountings for holding and rotating the sound source and test transmitter element in the following positions.

- a. Rotation about its axis through 360 degrees.
- b. Rotation through 180 degrees in a vertical plane perpendicular to the transmitter diaphragm.

4.1.1.3 Sound pressure calibration. Mount the condenser microphone concentrically in a baffle having the same shape as the cap of the transmitter housing, so that the periphery of the plane of the protective grid of the microphone is flush with the front surface of the baffle. Mount the baffle and microphone in the specified test position. The electrical output of the microphone shall be measured either with a volume level indicator or a vacuum tube voltmeter. The electrical input to the sound source from the:

- a. Band frequency oscillator shall be adjusted at individual frequencies in the 600 Hz to 1,600 Hz range to obtain sound pressures within ± 2 dB of the mean band frequency pressure specified.
- b. Audio oscillator shall be adjusted to obtain the specified sound pressure at each test frequency.

4.2 Classification of inspection. The inspections specified herein shall be classified as follows:

- a. Materials inspection (see 4.3).
- b. First article inspection (see 4.5).
- c. Quality conformance inspection (see 4.6).

4.3 Materials inspection. Materials inspection shall consist of certification supported by verifying data that the materials listed in table I, used in fabricating the handsets, are in accordance with the applicable referenced specifications or requirements prior to such fabrication.

TABLE I. Materials inspection.

Material	Requirement paragraph	Applicable specification
Brass	3.3	QQ-B-613 or QQ-B-626
Cloth	3.3	MIL-C-2069
Coating (black oxide)	3.3	MIL-C-13924
Copper beryllium strip	3.3	QQ-C-533
Copper, cartridge brass	3.3	MIL-C-50
Copper-nickel-zinc alloy	3.3	QQ-C-585
Cord and cable	3.3	MIL-C-3849 or MIL-C-3885
Finishes	3.3	MIL-F-14072
Fungus-resistant materials	3.3	MIL-STD-454 or MIL-T-152
Insulation	3.3	MIL-I-631 or MIL-I-3930 or MIL-I-4997
Rubber	3.3	MIL-R-3065
Silicone compound	3.3	MIL-S-8660
Tin plating	3.3	MIL-T-10727
Solder	3.3	QQ-S-571
Steel	3.3	QQ-S-763 or QQ-S-766
Wire	3.3	MIL-W-76 or MIL-W-3795

MIL-H-11996B

4.4 Inspection conditions and preconditioning.

4.4.1 Conditions. Unless otherwise specified herein, all inspections shall be performed in accordance with the test conditions specified in the "GENERAL REQUIREMENTS" of MIL-STD-202. All acoustical testing except operational testing shall be made in an environment where the ambient noise level shall be at least 6 dB lower than the test levels involved.

4.4.2 Bounce preconditioning. The handset shall be placed in its normal operating position on the table of the Package Tester as made by the L.A.B. Corporation, Skaneateles, New York 13152, or equal. The package tester, shafts in phase, shall have a speed such that it is just possible to insert a 1/32-inch-thick strip of material under one corner or edge of the handset to a distance of 3 inches as the handset bounces. The handset shall be subjected to 1 minute of this bounce preconditioning. Following the bounce preconditioning, the handset shall not be repaired, adjusted, aligned, cleaned, or otherwise changed prior to the first article or quality conformance inspection.

4.5 First article inspection (see 3.2). First article inspection shall be performed by the contractor after award of contract and prior to production, at a location acceptable to the Government. First article inspection shall be performed on sample units which have been produced with equipment and procedures normally used in production. First article approval is valid only on the contract under which it is granted, unless extended by the Government to other contracts.

4.5.1 Sample size. Twelve handsets shall be subjected to first article inspection.

4.5.2 Inspection routine. The sample shall be subjected to the inspections specified in table II, in the order shown. All sample units shall be subjected to the inspections of group I. The sample shall then be divided equally into three groups and subjected to the inspections for their particular group.

TABLE II. First article inspection.

Inspection	Requirement paragraphs	Method paragraph
<u>Group I</u>		
Visual and mechanical	3.3, 3.4 thru 3.4.13, inclusive and 3.16 thru 3.18 inclusive	4.7.1
Receiver	3.5	4.7.2
Sensitivity	3.5.1	4.7.2.1
Frequency response	3.5.2	4.7.2.2
Impedance	3.5.3	4.7.2.3
Overload	3.5.4	4.7.2.4
Magnetic stability	3.5.5	4.7.2.5
Dielectric strength and leakage resistance	3.5.6	4.7.2.6
Transmitter	3.6	4.7.3
Sensitivity	3.6.1	4.7.3.1
Frequency response	3.6.2	4.7.3.2
Frequency band response	3.6.3	4.7.3.3
Resistance	3.6.4	4.7.3.4
Unagitated current	3.6.5	4.7.3.5
Thermal voltage	3.6.6	4.7.3.6
Operational (talk)	3.7	4.7.4
<u>Group II</u>		
Vibration	3.8	4.7.5
Immersion	3.9	4.7.6
Shock (drop)	3.10	4.7.7
Thermal shock	3.11	4.7.8
<u>Group III</u>		
Tumbling	3.12	4.7.9
Relative humidity	3.13	4.7.10
Gunblast resistance	3.14	4.7.11
<u>Group IV</u>		
Switches (when applicable)	3.15	4.7.12

MIL-H-11996B

4.5.3 Failures. Any failures in groups I and IV, and more than one failure in groups II and III shall be cause for refusal to grant first article approval.

4.6 Quality conformance inspection.

4.6.1 Inspection of product for delivery. Inspection of product for delivery shall consist of groups A and B inspection.

4.6.1.1 Inspection lot. An inspection lot shall consist of all handsets of the same type, produced under essentially the same conditions, and offered for inspection at one time.

4.6.1.2 Group A inspection. Group A inspection shall consist of the examination and test specified in table III, in the order shown.

4.6.1.2.1 Sampling plan. Statistical sampling and inspection shall be in accordance with MIL-STD-105 for general inspection level II. The acceptable quality level (AQL) shall be as specified in table III. Major and minor defects shall be as defined in MIL-STD-105.

TABLE III. Group A inspection.

Inspection	Requirement paragraph	Method paragraph	AQL (percent defective)	
			Major	Minor
Visual and mechanical- - - - -	3.3, 3.4 thru 3.4.13 inclusive, 3.16 thru 3.18 inclusive	4.7.1	1.0	4.0
Receiver element - - - - -	3.5	4.7.2		
Sensitivity - - - - -	3.5.1	4.7.2.1		
Frequency response - - - - -	3.5.2	4.7.2.2		
Impedance - - - - -	3.5.3	4.7.2.3		
Dielectric strength and leakage resistance - - - - -	3.5.6	4.7.2.6	1.0	---
Transmitter element	3.6	4.7.3		
Sensitivity	3.6.1	4.7.3.1		
Frequency response	3.6.2	4.7.3.2		
Frequency band response	3.6.3	4.7.3.3		
Resistance	3.6.4	4.7.3.4		
Operational (talk)	3.7	4.7.4	1.0	---

4.6.1.2.2 Rejected lots. If an inspection lot is rejected, the contractor may rework it to correct the defects, or screen out the defective units, and resubmit for reinspection. Resubmitted lots shall be inspected using tightened inspection. Such lots shall be separate from new lots, and shall be clearly identified as reinspected lots.

4.6.1.3 Group B inspection. Group B inspection shall consist of the test specified in table IV and shall be made on sample units which have been subjected to and have passed group A inspection.

4.6.1.3.1 Sampling plan. The sampling plan shall be in accordance with MIL-STD-105 for special inspection level S-4. The AQL shall be 6.5 percent defective.

TABLE IV. Group B inspection.

Inspection	Requirement paragraph	Method paragraph
Receiver- - - - -	3.5	4.7.2
Overload- - - - -	3.5.4	4.7.2.4
Magnetic stability- - - - -	3.5.5	4.7.2.5
Transmitter- - - - -	3.6	4.7.3
Unagitated current - - - - -	3.6.5	4.7.3.5
Thermal voltage- - - - -	3.6.6	4.7.3.6

MIL-H-11996B

4.6.1.3.2 Rejected lots. If an inspection lot is rejected, the contractor may rework it to correct the defects, or screen out the defective units, and resubmit for reinspection. Resubmitted lots shall be inspected using tightened inspection. Such lots shall be separate from new lots, and shall be clearly identified as reinspected lots.

4.6.1.3.3 Disposition of sample units. Sample units which have passed the group B inspection may be delivered on the contract or purchase order if the lot is accepted and the sample units are still within specified electrical tolerances.

4.6.1.4 Group C inspection. Group C inspection shall consist of the tests specified in table V, in the order shown. Group C inspection shall be made on sample units selected from inspection lots which have passed groups A and B inspections.

4.6.1.4.1 Sampling plan. Group C inspection shall be performed once each month on nine sample units selected without regard to their quality from units produced during the period of each 1,000 units, whichever occurs first. The sample shall be divided equally into three groups and subjected to the tests of subgroups 1 and 2, and 3 when applicable, of table V.

4.6.1.4.2 Failures. If one or more sample units fail to pass group C inspection, the sample shall be considered to have failed.

TABLE V. Group C inspection.

Test	Requirement paragraph	Method paragraph
<u>Subgroup I</u>		
Vibration - - - - -	3.8	4.7.5
Immersion - - - - -	3.9	4.7.6
Shock (drop) - - - - -	3.10	4.7.7
<u>Subgroup II</u>		
Thermal shock - - - - -	3.11	4.7.8
Tumbling - - - - -	3.12	4.7.9
Relative humidity - - - - -	3.13	4.7.10
<u>Subgroup III</u>		
Switches (when applicable)	3.15	4.7.12

4.6.1.4.3 Disposition of sample units. Sample units which have been subjected to group C inspection shall not be delivered on the contract or purchase order.

4.6.1.4.4 Noncompliance. If a sample fails to pass group C inspection, the manufacturer shall notify the qualifying activity and the cognizant inspection activity of such failure and take corrective action on the materials or processes, or both, as warranted, and on all units of product which can be corrected and which were manufactured under essentially the same conditions, with essentially the same materials and processes, and which are considered subject to the same failure. Acceptance and shipment of the product shall be discontinued until corrective action has been taken, group C inspection shall be repeated on additional sample units (all inspection, or the inspection which the original sample failed, at the option of the qualifying activity). Groups A and B inspection may be reinstated; however, final acceptance and shipment shall be withheld until the group C inspection has shown that the corrective action was successful. In the event of failure after reinspection, information concerning the failure shall be furnished to the cognizant inspection activity and the qualifying activity.

MIL-H-11996B

4.6.2 Inspection of packaging. Except when commercial packaging is specified the preservation, and interior package marking shall be in accordance with the group A and B quality conformance inspection requirements of MIL-P-116. The inspection of the packing and marking for shipment and storage shall be in accordance with the quality assurance provisions of the applicable container specification and the marking requirements of MIL-STD-129. The inspection of commercial packaging shall be as specified in the contract (see 6.2)

4.7 Methods of examination and test.

4.7.1 Visual and mechanical examination. The Handsets shall be examined to verify that the materials, design, construction, physical dimensions, interchangeability, marking, and workmanship are in accordance with the applicable requirements (see 3.3, 3.4 thru 3.4.13 inclusive, and 3.16 thru 3.18 inclusive.)

4.7.2 Receiver element.

4.7.2.1 Sensitivity (see 3.5.1). Sensitivity measurement shall be made at 1,000 Hz in accordance with S3.7-1973(R1971), using a preferred source resistance of 150 ohms and a type 1 coupler. The standard testing level of 20 dynes per square centimeter at 1,000 Hz shall be used, and 1 mW (0.775 volts rms) shall be applied.

4.7.2.2 Frequency response (see 3.5.2). Available power frequency response measurement shall be made starting at 500 Hz and extending through 3,200 Hz in sufficient detail to establish definitely the shape of the curve. Response measurements shall be made in accordance with S3.7-1973(R1971) using a preferred source resistance of 150 ohms and a type 1 coupler. The standard testing level of 20 dynes per square centimeter at 1 kHz shall be used, and 1 mW (0.775 volts rms) shall be applied.

4.7.2.3 Impedance (see 3.5.3). The receiver elements shall be measured while mounted as specified for the frequency response test. Connect the receiver element, in series with a noninductive resistance at least 100 times the rated impedance of the magnetic receiver element, to a source of alternating voltage at 1,000 Hz. Adjust the source voltage to obtain 0.06 volts rms across the receiver element. Replace the receiver element with a variable noninductive resistance, and without changing the source voltage, adjust the variable resistance to obtain the same voltage as for the receiver element. The ohmic value of the resistance necessary to obtain the rms voltage reading shall be considered, as the impedance of the receiver element.

4.7.2.4 Overload (see 3.5.4). The receiver element shall be tested with a source of voltage whose frequency varies over the range of 500 Hz to 2,500 Hz, the voltage of the source shall be adjusted to provide 1 milliwatt into a resistive load equal in value to the specified impedance of the receiver. The receiver shall then be substituted for the load resistance and placed in close proximity to the ear, and examined for evidence of rattling or distortion.

4.7.2.5 Magnetic stability (see 3.5.5). With the receiver element protected with a click reducer (see 3.4.1) it shall be subjected to a total of six successive discharges of opposite polarity from a 10 microfarad capacitor charged to 130 volts.

4.7.2.6 Dielectric strength and leakage resistance (see 3.5.6). The insulation between the receiver element windings and the core, and between the case and terminals shall receive the application of 500 volts rms 60 Hz for 5 seconds.

4.7.3 Transmitter element.

4.7.3.1 Sensitivity (see 3.6.1). The transmitter sensitivity shall be the level at 1,000 Hz determined with the test procedure in 4.7.3.2.

MIL-H-11996B

4.7.3.2 Frequency response (see 3.6.2). Having calibrated the sound source as specified, (see 4.1.1.3) replace the condenser microphone and its baffle with the transmitter element assembled in its housing with its grid located as specified (4.1.1.2) in the vertical position. Connect the transmitter in the circuit shown on figure 3. With the 40 ohm resistor in circuit in place of the transmitter element, adjust the 250 ohm resistor to obtain a direct current of .085 ampere. With the transmitter diaphragm in the vertical plane and with no current flowing, rotate the transmitter smoothly about its axis through an arc of approximately 270 degrees and back to its original position two times at a uniform rate of approximately 1 complete cycle (270 degrees and back) in 2 seconds. Then rotate the test apparatus (see 4.1.1.2) to the position in which the transmitter is to be tested. Close the circuit and wait approximately 3 seconds for current stabilization. Apply an agitation sweep signal varying uniformly from 1,000 Hz to 3,000 Hz and back to 1,000 Hz every 2 seconds. The agitation intensity of this sweep signal shall be adjusted so that the maximum sound pressure obtained during the sweep is 70 dynes/cm². At the conclusion of the third sweep, the audio oscillator shall be shut off so as not to destroy the previous conditioning. After approximately 3 seconds delay, turn on the test tone signal and using a sound pressure of 28 dynes/cm², the voltage frequency response measurements shall be made starting at 300 Hz and extending through 4,000 Hz in sufficient detail to establish definitely the shape of the curve.

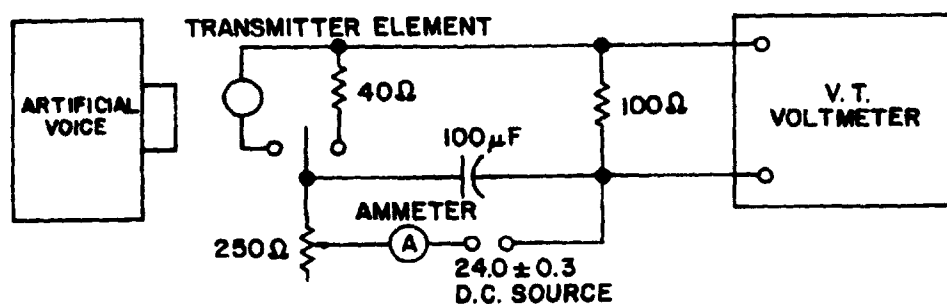
FIGURE 3 Constant current circuit

4.7.3.3 Frequency band response (see 3.6.3). With the transmitter in the sound field, connect the element in the circuit as shown on figure 4, assembled in its housing with its grid located as specified (see 4.1.1.2). With the transmitter diaphragm in the vertical plane and with current flowing, rotate the transmitter element smoothly about its axis through an arc of approximately 270 degrees and back to its original position two times at a uniform rate of approximately one complete cycle in 2 seconds. Apply the band frequency at a mean pressure of 56 dynes/cm² for 3 seconds. After 3 seconds without agitation, apply the band frequency at 28 dynes/cm², and at the end of 3 seconds, read the output voltage.

4.7.3.4 Resistance (see 3.6.4). With the circuit set up as shown on figure 3, place the transmitter in a vertical position in its fixture with its leads shorted. Remove the short and with the current flowing, rotate the element as specified in 4.7.3.2. After approximately 3 seconds, apply 1 cycle of an agitation sweep signal varying uniformly from 1,000 Hz to 3,000 Hz and back to 1,000 Hz in approximately 2 seconds. The maximum sound pressure of the signal during the sweep is 28 dynes/cm². With the signal set at 1,000 Hz and the sound pressure at 28 dynes/cm², measure the dc voltage across the transmitter element with a high resistance dc voltmeter (at least 1,000 ohms/volt).

4.7.3.5 Unagitated current (see 3.6.5). The transmitter element in its housing in the vertical position shall be connected into a test circuit (see figure 5). The transmitter shall be rotated as specified in 4.7.3.2. The circuit shall then be closed and 10 readings of current at intervals of approximately 1 minute shall be taken. The highest reading shall be considered the maximum unagitated current.

NOTE: This test shall be performed in a place that is relatively free from noise and vibration.

MIL-H-11996B

4.7.3.6 Thermal voltage (see 3.6.6). The test circuit shall be as shown on figure 3, except with the direct current adjusted to 170 milliamperes.

NOTE: The transmitter element shall be tested in a circuit and a location sufficiently free from noise and vibration so that the transmitter element output results from disturbances generated within the transmitter element only.

Connect the transmitter element in the circuit with current flowing, rotate the transmitter as specified in 4.7.3.2. Then rotate the test apparatus to the position the transmitter is to be tested in. Agitate for 10 seconds with a sweep signal varying uniformly from 1,000 to 3,000 Hz and back to 1,000 Hz every 2 seconds, with the agitation intensity adjusted so that the maximum sound pressure obtained during the sweep is 70 dynes per square centimeter. Then with the agitation off, measure the thermal ac voltage across the load resistor generated by the microphone.

4.7.4 Operational (talk) (see 3.7). Completely assembled handsets shall be tested by a two-way talk-test to insure correct wiring and satisfactory operation.

4.7.5 Vibration (see 3.8). The handset shall be tested in accordance with method 201 of MIL-STD-202. The following details shall apply:

- a. Frequency response of receiver and transmitter element.
- b. Method of mounting - Mount so the vibration within the handset can be observed and measured. (To facilitate the observation and measurement, subassemblies may be tested separately provided they are secured to the table in a manner similar to that used to mount them in the handle.
- c. Duration of vibration - Change frequency in steps of 1 Hz and maintain each frequency for at least 10 seconds.
- d. Test and measurements during and after vibration - Measure vibration amplitudes by optical means, or by other means provided that vibrations of the part is not affected by the measurement.
- e. Following the test the handset shall be examined for physical or electrical defects and frequency response shall be measured as specified in 4.7.2.2 and 4.7.3.2.

4.7.6 Immersion (see 3.9). The completed handset shall be immersed for 10 minutes in tap water to a depth of 3 feet. Immediately prior to immersion, the temperature of the equipment shall be 40°F or more above the temperature of the water. The tank the handset is immersed in shall be of sufficient capacity to maintain the water within $\pm 2^\circ\text{F}$ of its initial temperature or the temperature of the water shall be maintained within these limits by other means for the duration of the test. Following the test, the handset shall be examined for damage and frequency response shall be measured as specified in 4.7.2.2 and 4.7.3.2.

4.7.7 Shock (drop) (see 3.10). The handset shall be dropped at least six times from a height of 6 feet on a concrete floor. The handset shall strike at least once on the receiver and once on the transmitter end. Following the test, the handset shall be examined for damage to the handle due to breaking or cracking and the frequency response shall be measured as specified in 4.7.2.2 and 4.7.3.2.

4.7.8 Thermal shock (see 3.11). The handset shall be tested in accordance with method 107 of MIL-STD-202. The following details shall apply:

- a. Test condition - A.
- b. Final measurement - At the completion of the final cycle when the handset has returned to thermal stability at room ambient temperature the handset shall be examined for damage and frequency response shall be measured as specified in 4.7.2.2 and 4.7.3.2.

4.7.9 Tumbling (see 3.12). The completed handset, less cord, shall be subjected to 500 revolutions in a 16-inch drop, standard rotary tester. The floor of the tester shall be 3/16-inch Masonite or equal (Brinell hardness No. 11 to No. 13), backed by wood. Following the test, the handset shall be examined for damage and frequency response shall be measured as specified in 4.7.2.2 and 4.7.3.2.

MIL-H-11996B

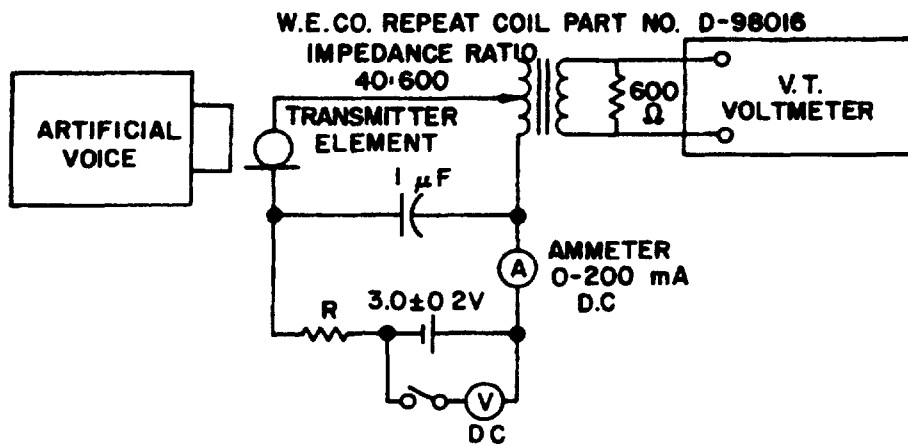

NOTES:

1. The transformer loss shall not exceed 1.0 dB and shall not vary more than 0.2 dB over the frequency range from 300 to 4000 Hz.
2. The resistance of the circuit exclusive of the transmitter element should be 10 ohms.

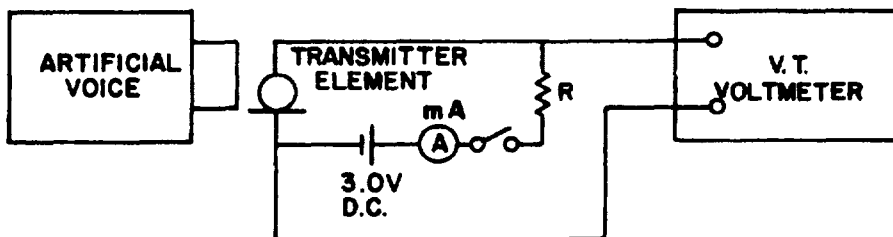
FIGURE 4 Constant voltage circuit

NOTE: Circuit resistance shall be 10 ohms exclusive of the transmitter element.

FIGURE 5. Three volt circuit.

MIL-H-11996B

4.7.10 Relative humidity (see 3.13). The handsets shall be tested in accordance with method 507 of MIL-STD-810. The following details shall apply:

- a. Frequency response of receiver element and transmitter element.
- b. Procedure - number III.
- c. Handset need not be exposed to extreme high temperature before test.
- d. Number of cycles - 5 cycles.
- e. Following the test the handsets shall be examined for damage and frequency response shall be measured as specified in 4.7.2.2 and 4.7.3.2.

4.7.11 Gunblast resistance (see 3.14). The handset shall be mounted on the carriage of the U.S. Navy Simulated Gunblast Equipment, in accordance with SK-N-864, or equal. The handset shall be mounted at the reference plane with the transmitter and receiver diaphragms facing the blast source. The handset shall be subjected to 30 rounds of blast at a peak pressure of 9.5 pounds per square inch. After the test, handsets shall be examined for damage and frequency response shall be measured as specified in 4.7.2.2 and 4.7.3.2.

4.7.12 Switches (when applicable see 3.1)(see 3.15). The switch shall be subjected to 100,000 make-and-break cycles at a rate not to exceed 12 cycles per minute. Tests requiring repetitive operation of switches shall be made using a suitable device arranged to move the switch level into each "ON" position and back to the original position to complete one cycle of operation, and thereby causing the switching mechanism to make-and-break (or break-and-make) all the circuits in which the switch is connected.

5. PACKAGING

5.1 Preservation. Preservation shall be level A or C, or as specified (see 6.2).

5.1.1 Level A.

5.1.1.1 Cleaning. Handsets shall be cleaned in accordance with MIL-P-116, process C-1.

5.1.1.2 Drying. Handsets shall be dried in accordance with MIL-P-116.

5.1.1.3 Preservative application. Preservatives shall not be used.

5.1.1.4 Unit packaging. Handsets shall be individually unit packaged in accordance with submethod IC-2 of MIL-P-116, insuring compliance with the applicable requirements of that specification.

5.1.1.5 Intermediate packaging. Not required.

5.1.2 Level C. The level C preservation for handsets shall conform to the MIL-STD-794 requirements for this level.

5.2 Packing. Packing shall be level A, B, or C, or as specified (see 5.4.3 and 6.2).

5.2.1 Level A. The packaged handsets shall be packed in fiberboard containers conforming to PPP-B-636, class weather resistant, style optional special requirements. In lieu of the closure and waterproofing requirement in the appendix of PPP-B-636, closure and waterproofing shall be accomplished by sealing all seams, corners, and manufacturer's joint with tape, 2 inches minimum width, conforming to PPP-T-60, class 1 or PPP-T-76. Banding (reinforcement requirements) shall be applied in accordance with the appendix to PPP-B-636 using non-metallic or tape banding only.

5.2.2 Level B. The packaged handsets shall be packed in fiberboard containers conforming to PPP-B-636, class domestic, style optional, special requirements. Closures shall be in accordance with the appendix thereto.

5.2.3 Level C. The level C packing for handsets shall conform to the MIL-STD-794 requirements for this level.

MIL-H-119968

5.2.4 Unitized loads. Unitized loads, commensurate with the level of packing specified in the contract or order, shall be used whenever total quantities for shipment to one destination equal 40 cubic feet or more. Quantities less than 40 cubic feet need not be unitized. Unitized loads shall be uniform in size and quantities to the greater extent practicable.

5.2.4.1 Level A. Handsets, packed as specified in 5.2.1, shall be unitized on pallets in conformance with MIL-STD-147, load type I, with a fiberboard cap (storage aid 4) positioned over the load.

5.2.4.2 Level B. Handsets, packed as specified in 5.2.2, shall be unitized as specified in 5.2.4.1 except that the fiberboard caps shall be class domestic.

5.2.4.3 Level C. Handsets, packed as specified in 5.2.3, shall be unitized with pallets and caps of the type, size, and kind commonly used for this purpose. These unitized loads shall conform to the applicable carrier rules and regulations and may be the contractor's commercial practice when such meets the requirements of this level.

5.3 Marking. In addition to any special marking required by the contract or purchase order (see 6.2), each unit pack, exterior container and unitized load shall be marked in accordance with MIL-STD-129.

5.4 General.

5.4.1 Exterior containers. Exterior containers (see 5.2.1, 5.2.2, and 5.2.3) shall be of a minimum tare and cube consistent with the protection required and shall contain equal quantities of identical stock numbered items to the greatest extent practicable.

5.4.2 Packaging inspection. The inspection of these packaging requirements shall be in accordance with 4.6.2.

5.4.3 Army procurements.

5.4.3.1 Level A and B packing. For level A packing when quantities per destination are less than a unitized load, the fiberboard containers shall not be banded but shall be placed in a close fitting box conforming to PPP-B-601, overseas type, PPP-B-621, class 2, style 4, or PPP-B-585, class 3, style 2 or 3. Closure and strapping shall be in accordance with the applicable container specification except that metal strapping shall conform to QQ-S-781, type I, finish A. When the gross weight exceeds 200 pounds or the container length and width is 48 x 24 inches or more and the weight exceeds 100 pounds, 3 x 4 inch skids (laid flat) shall be applied in accordance with the requirements of the container specification. If not described in the container specification, the skids shall be applied in a manner which will adequately support the item and facilitate the use of material handling equipment. For level B packing, fiberboard boxes shall be weather resistant as specified in level A and the containers shall be banded (see 5.2.1, 5.2.2, and 6.2).

5.4.3.2 Level A and B unitization. For level A and B unitization, the fiberboard caps shall be weather resistant and softwood pallets conforming to MN-P-71, type VI, size 2 shall be used. The loads shall be banded to the pallets by strapping conforming to QQ-S-781, type I, finish A or shrink film (see 5.2.4.1 and 5.2.4.2).

5.4.3.3 Commercial packaging. Commercial packaging (including preservation, packing, and marking) shall be in accordance with MIL-STD-1188.

6. NOTES

6.1 Intended use. Handsets covered in this specification are intended for use with wire and radio communications equipment in locations with extreme environmental conditions. The handset H-6U()/U is intended to be used as part of the intercom station AN/VIA-4, AN/MTC-3(). The handset - H-156()/U is intended to be used as part of the AN/GRC-50A(V) 1 thru 5, AN/TRC-143. The handset - H-165()/U is intended to be used as part of the C-1632/VIA-4 that is a component of the AN/VIA-4, AN/MTC-3().

MIL-H-11996B

6.2 Ordering data. The contract or purchase order should specify the following:

- a. Title, number, and date of this specification.
- b. Title, number, and date of the applicable specification sheet and the applicable type number (see 3.1).
- c. Inspection of commercial packaging (see 4.6.2).
- d. Levels of preservation-packaging and packing required (see 5.1, 5.2, 5.4.3.1, and 5.4.3.3).
- e. Method of preservation, if other than submethod IA-15 (see 5.1.1.4).
- f. Special marking, if required (see 5.3).

6.3 First article inspection. Information pertaining to first article inspection of components covered by this specification should be obtained from the procuring activity for the specific contracts involved (see 3.2 and 4.5).

6.4 Changes from previous issue. Asterisks are not used in this revision to identify changes with respect to the previous issue due to the extensiveness of the changes.

Custodians:

Army - CR
Navy - EC
Air Force - 85

Review activities:

Army - MI, AR, SM
Air Force - 99
DLA - ES

Preparing activity:

Army - CR

Agent:

DLA - ES

(Project 5965-0170)