

INCH-POUND

MIL-F-87260(USAF)

7 February 1992

FOAM MATERIAL, EXPLOSION SUPPRESSION, INHERENTLY ELECTRICALLY CONDUCTIVE, FOR AIRCRAFT FUEL TANK AND DRY BAY AREAS

This specification is approved for use by
the Department of the Air Force and is available for use by all
Departments and Agencies of the Department of Defense.

1. SCOPE

1.1 Scope. This document covers the requirements for an electrically conductive open-celled foam material that will be used for explosion suppression in aircraft fuel tanks and dry bay areas (cavities).

1.2 Classification. The conductive explosion suppression material (ESM) shall be of the following classes and grades (see 6.6):

Class 1 - ESM to be used for single point and over-wing refueling throughout the temperature range of 0 to +160°F

Grade IC - Coarse pore

Grade IIC - Fine pore

Class 2 - ESM to be used for single point and over-wing refueling throughout the temperature range of -30 to +160°F

Grade IC - Coarse pore

Grade IIC - Fine pore

All types of ESM of both classes shall have a nominal density of 1.3 lbs/cu ft.

2. APPLICABLE DOCUMENTS

2.1 Government documents

2.1.1 Specifications, standards, and handbooks. The following specifications, standards, and handbooks form a part of this document to the extent specified herein. Unless otherwise specified, the issues of these documents are those listed in the issue of the Department of Defense Index of Specification and Standards (DODISS) and supplement thereto, cited in the solicitation (see 6.2).

Beneficial comments (recommendations, additions, deletions) and any pertinent data which may be of use in approving this document should be addressed to: ASD/ENES, Wright-Patterson AFB, OH 45433-6503 by using the Standardization Document Improvement Proposal (DD form 1426) appearing at the end of this document or by letter.

AMSC: N/A

FSC: 9330

DISTRIBUTION STATEMENT A: Approved for public release; distribution is unlimited.

MIL-F-87260(USAF)**SPECIFICATIONS****Federal**

A-A-208	Ink, Marking, Stencil, Opaque (Porous and Non-Porous Surfaces)
L-P-378	Plastic, Sheet and Strip, Thin Gauge, Polyolefin
QQ-A-250/4	Aluminum Alloy 2024, Plate and Sheet
QQ-A-250/12	Aluminum Alloy 7075, Plate and Sheet
QQ-P-35	Passivation Treatments for Corrosion-Resistant Steel
TT-S-735	Standard Test Fluids, Hydrocarbon
PPP-B-636	Boxes, Shipping, Fiberboard

Military

MIL-P-116	Preservation, Methods of
MIL-T-5624	Turbine Fuel, Aviation, Grade JP-4, JP-5, and JP-5/JP-8 ST
MIL-I-27686	Inhibitor, Icing, Fuel System
MIL-B-83054	Baffle and Inerting Material, Aircraft Fuel Tank
MIL-T-83133	Turbine Fuels, Aviation, Kerosene Types, NATO F-34 (JP-8) and NATO F-35
MIL-C-87936	Cleaning Compounds, Aircraft Exterior Surfaces, Water Dilutable

STANDARDS**Federal**

Fed. Test Method Std. No. 101 (Method 4046.1)	Test Procedures for Packaging Materials: "Electrostatic Properties of Materials"
---	--

Military

MIL-STD-129	Marking for Shipment and Storage
MIL-STD-831	Test Reports, Preparation of
MIL-STD-2073-1	DoD Material Procedures for Development and Application of Packaging Requirements
MIL-STD-2073-2	Packaging Requirement Codes

(Unless otherwise indicated, copies of federal and military specifications, standards, and handbooks are available from the Standardization Documents Order Desk, Building 4D, 700 Robbins Avenue, Philadelphia, PA 19111-5094.)

2.1.2 Other Government documents, drawings, and publications. The following other Government documents, drawings, and publications form a part of this document to the extent specified herein. Unless otherwise specified, the issues are those cited in the solicitation.

MIL-F-87260(USAF)**TEST REPORTS**

Air Force Engineering and Service Center

ESC-TR-84-63 Effective Disposal of Fuel Cell Polyurethane Foam

(Copies of this report are available from the National Technical Information Service (NTIC), 5285 Port Royal Road, Springfield VA 22161.)

AIR FORCE TECHNICAL ORDER

T.O. 42B-1-1 Quality Control of Fuels and Lubricants

(Copies of Air Force Technical orders are available through your contracting officer from Oklahoma City Air Logistics Center (OC-ALC/MMEDT), Tinker Air Force Base, OK 73145-5990.)

2.2 Non-government publications. The following documents form a part of this document to the extent specified herein. Unless otherwise specified, the issues of the documents which are DOD adopted are those listed in the issue of the DODISS specified in the solicitation. Unless otherwise specified, the issues of documents not listed in the DODISS are the issues cited in the solicitation (see 6.2).

American Society for Testing and Materials (ASTM)

D257-78 Standard Test Methods for DC Resistance or Conductance of Insulating Materials

F1110-88 Standard Test Method for Sandwich Corrosion Test

D1655-89 Standard Specification for Aviation Turbine Fuels

D2276-89 Standard Test Methods for Particulate Contaminant in Aviation Turbine Fuels

D3574-86 Standard Methods of Testing Flexible Cellular Materials - Slab, Bonded, and Molded Urethane Foams

Society of Automotive Engineers, Inc. (SAE)

AIR-4170 Reticulated Polyurethane Foam Explosion Suppression Material for Fuel Systems and Dry Bays

(Application for copies of ASTMs should be addressed to the American Society for Testing and Materials, 1916 Race Street, Philadelphia, PA 19103. Application for copies of SAEs should be addressed to the Society of Automotive Engineers, Inc., 400 Commonwealth Drive, Warrendale, PA 15096. Copies not available in the current ASTM standards may be obtained from the procuring activity.)

(Non-Government standards and other publications are normally available from the organizations that prepare or distribute the documents. These documents also may be available in or through libraries or other informational services.)

2.3 Order of precedence. In the event of a conflict between the text of this document and the references cited herein (except for related associated detail specifications, specification sheets, or MS standards), the text of this document takes precedence. Nothing in this document, however, supersedes applicable laws and regulations unless a specific exemption has been obtained.

MIL-F-87260(USAF)**3. REQUIREMENTS**

3.1 Qualification. Material furnished under this specification shall be a product which is authorized by the qualifying activity for listing on the applicable qualified products list at the time of award of contract (see 4.4 and 6.4).

3.1.1 Requalification. Before any change is made in the quality, composition, source of ingredients, or source of supply of the final product, the manufacturer must contact the qualifying activity to determine if requalification or partial requalification is required (see 6.4.1).

3.2 Materials. The raw materials used in processing the material shall be of the highest quality and standards for commercially available products of this type and shall be of the same formulation as that used in the qualification test sample. The end product shall be a flexible urethane foam which is suitable for use in aircraft fuel tanks. The final product shall be a material which is inherently electrically conductive.

3.2.1 Product toxicological data and disposal. Product toxicological data relating to the kit processing and end use, particularly by hot wire thermal decomposition, shall be submitted in the qualification test report for review by an appropriate military medical authority who will determine if any use restrictions exist relative to the safety of personnel. In addition, available data relating to possible methods of disposal for the foam material shall be provided. This includes both new material and material that has been exposed to fuel in an aircraft fuel tank. For additional guidelines on the disposal of fuel cell reticulated foams, consult ESC-TR-84-63.

3.2.2 Human exposure toxicology. The material shall not pose a toxicity hazard to personnel who come in contact with the product. Toxicological data substantiating its safety shall be provided along with the conductive material composition for review by military medical authority to verify personnel safety. All proprietary information shall be protected from disclosure in accordance with appropriate Federal regulations.

3.2.3 Tracer elements. A tracer element shall be incorporated into the material for identification purposes. The tracer element shall be submitted to the qualifying activity for approval and shall be unique to each vendor. The manufacturer shall also supply the analytical test procedure which can be used to identify the tracer element.

3.2.4 Manufacturer internal specification and production quality control documents. The conductive material manufacturer shall provide adequate internal documents (specifications/manuals) to define and control the production, testing, and quality control of the material. This qualification documentation shall include, as a minimum, the manufacturer's quality control manual and internal specification which describe such items as: manufacturer's product, product part numbers, available bun sizes, production testing and frequency of the production tests, testing requirements (limits), quality control procedures, and any other information relative to the materials' certification or usage. This document(s) shall be made available for use by the DCASMA personnel during production facility inspections and during material procurement certification. The vendor's quality control document(s) should also be referenced in the product qualification report and a copy provided to the qualifying agency as part of the qualification package.

3.3 Age. The maximum time of delivery from the manufacturer shall not exceed one year. If the time since manufacture exceeds six months, the material shall be visually inspected, and there shall be no evidence of discoloration resulting in surface deterioration which results in a loss of tension properties. Discoloration of urethane foams with age and exposure to ultraviolet light is a normal occurrence and does not necessarily indicate deterioration.

3.3.1 Storage life. The storage life of the material covered by this specification is not limited, provided it is maintained in the original sealed polyethylene bag plus opaque overwrap at temperatures below 90°F. Storage should be in an area out of direct sunlight and outside weather, including high humidity and temperature. The material should be inspected for evidence of discoloration or surface deterioration (loss in tensile properties) prior to use.

3.4 Coloring pigments. Coloring pigments or coatings shall not be readily extractable when the conductive material is used in contact with fuels conforming to MIL-T-5624, MIL-T-83133, and ASTM D-1655. Product color is not limited except that it shall not be blue, orange, yellow, or red.

MIL-F-87260(USAF)

3.5 Marker legibility. The manufacturer shall identify a suitable marker for use on the conductive material kit pieces (individual identification numbers) to be installed in the aircraft fuel system. The marker shall be compatible with both fuel and the conductive material. A possible source for a fuel compatible marking ink is A-A-208. A suggested marking pen is available from the Diagraph Corporation, Herrin, Illinois. The identification for a white opaque pigment (valve action marker) is GP-X.

3.6 Physical properties and characteristics. The physical properties and characteristics of the conductive material at the time of manufacture shall be suitable for the purpose intended and in accordance with Table I and the applicable paragraphs of Section 3.

TABLE I. Physical properties and characteristics.

Property	Requirement		
	Grade I	Grade II	Test Para. Ref.
Color	See 4.6.2	See 4.6.2	4.6.2
Density Range (lbs/ft ³)	1.20-1.50	1.20-1.50	4.6.3
Density Uniformity (lbs/ft ³)	Report	Report	4.6.3
Porosity (Air Pressure Drop)*	7.5-21.0	21.5-33.0	4.6.4
Air Pressure Drop (in. water)	0.150-0.250	0.260-0.360	4.6.4
Tensile Strength (psi)	10.0 min	15.0 min	4.6.5
Ultimate Elongation (percent)	100.0 min	100.0 min	4.6.5
Tear Resistance (psi)	3.0 min	3.0 min	4.6.6
Constant Deflection Compression Set (percent)	45.0 max	45.0 max	4.6.7
Compression Load Deflection at 25 percent (psi)	0.35 min	0.35 min	4.6.8
Compression Load Deflection at 65 percent (psi)	0.60 min	0.60 min	4.6.8
Fuel Displacement (vol percent)	2.50 max	2.50 max	4.6.9
Fuel Retention (vol percent) **	2.50 max	5.00 max	4.6.10
Water Retention (vol percent)	Report	Report	4.6.10
Flammability (in/min)	15.0 max	15.0 max	4.6.11
Extractable Materials (wt. percent)	3.0 max	3.0 max	4.6.12
Volume Increase (vol. percent)			
Type I Fluid	0-15.0	0-15.0	4.6.13
Type III Fluid	0-40.0	0-40.0	4.6.13
JP-4 Turbine Fuel	0-25.0	0-25.0	4.6.13
Low Temperature Flexibility	No Cracking or Breaking of Strands		4.6.14
Entrained Solid Contamination (mg/ft ³)	11.0 max	11.0 max	4.6.15
Steam Autoclave Exposure (percent tensile loss)	30.0 max	30.0 max	4.6.16
Electrical Resistivity (ohm-cm) at 75°F	1.0x10 ⁷ to 5.0x10 ¹¹		4.6.23
Electrical Resistivity Uniformity at 75°F	2 Orders of Magnitude from Top to Bottom		4.6.23

* For information only (Not for procurement certification)

** To be determined at the maximum air pressure drop limit

MIL-F-87260(USAF)

3.7 Performance requirements. The conductive material shall meet the following performance requirements (in addition to Table I):

3.7.1 Fuel immersion. The following fuel immersion requirements shall be met:

a. JP-4 immersion at 160°F. The material shall not undergo more than 40.0 percent loss in “dry-to-dry” and “wet-to-wet” tension properties after 4, 8, and 12 weeks exposure. In addition, the dry electrical resistivity property of the material after fluid exposure shall not rise above 5.0×10^{12} ohm-cm after exposures of 4, 8, and 12 weeks.

b. Wet property assessment at 75°F. The material shall not undergo more than 60.0 percent loss in tension, compression load deflection, and tear resistance properties from dry-to-wet after a 4-week exposure to JP-4 fuel.

3.7.2 Hydrolytic stability. The conductive material shall meet the following hydrolytic stability requirements:

a. Humidity exposure at 200°F/95 percent relative humidity. The material shall not undergo more than 65 percent loss in tensile strength after 6 weeks exposure. The electrical resistivity property of the material after exposure for 6 and 10 weeks shall not exceed 5.0×10^{12} ohm-cm.

b. Water immersion at 160°F. The material shall not undergo more than 40.0 percent loss in tensile strength after 12 weeks of exposure.

c. Dry bay-dry heat tests at 250°F. The material shall not undergo more than 65 percent loss in tensile strength after four weeks of exposure. The electrical resistivity property of the material shall also be reported on a minimum weekly basis for the duration of exposure and shall not exceed 5.0×10^{12} ohm-cm after four weeks exposure.

3.7.3 Explosion suppression and flame arrestor characteristics. The conductive materials shall meet the following minimum requirements:

a. Coarse pore material. The coarse pore material shall suppress the combustion overpressure for a single void ignition of 20.0 volume percent to a value equal to or below 15.0 psid (pounds per square inch differential).

b. Fine pore material. The fine pore material shall suppress the combustion overpressure for a single void ignition of 35.0 percent volume to a value equal to or below 15.0 psid. In addition, the fine pore material shall prevent flame propagation for the following conditions:

(1) At 0 psig initial pressure and a combustion volume of 16.7 percent volume, the required material thickness shall be 3.0 inches or less.

(2) At 3.0 psig initial pressure and a combustion volume of 16.7 percent volume, the required material thickness shall be 5.0 inches or less.

3.7.4 Corrosion and adhesion. The conductive material shall neither adhere to nor cause any pitting, erosion, or corrosion to aluminum alloy plates when in contact for 14 days.

3.7.5 Electrical resistivity permanence. The conductive material's electrical resistivity property shall not rise above 5.0×10^{12} ohm-cm after exposure to the following conditions:

Water immersion at $120 \pm 5^\circ\text{F}$ for four weeks. Water immersion at $160 \pm 5^\circ\text{F}$ for three weeks may be substituted.

3.7.6 Fuel compatibility. Properties of the JP-4 and JP-8 fuels exposed to the conductive material shall meet the following requirements listed in MIL-T-5624:

a. Color shall be equal to or greater than 15.0 saybolt color units.

- b. Existent gum shall not exceed 14.0 mg/100ml.
- c. Particulates shall not exceed 1.0 mg/liter.
- d. Filtration time shall not exceed 10.0 minutes.
- e. Total acid number shall not exceed 0.015 mg/KOH/g.
- f. JFTOT ΔP (260) shall not exceed 25.0 mm Hg.
- g. No visible extraction of material coloring pigment.

3.7.7 Electrical resistivity and electrostatic fuel impingement test. The electrical resistivity and electrostatic compatibility characteristics of the conductive material shall meet the following requirements:

a. The dry electrical resistivity of both classes of conductive material shall be between 1.0×10^7 and 5.0×10^{11} ohm-cm when tested at $75 \pm 5^\circ\text{F}$ and 10, 50, 95 ± 5 percent relative humidities. In addition the electrical resistivity shall be measured and reported for the following temperatures: 160, 32, 0, -20, -30, $-40 \pm 5^\circ\text{F}$.

b. Class I Materials. The Class I conductive materials shall not produce an incendiary vapor ignition, electrical discharges, or excessive static charge build-up (electrical activity) when impinged by JP-4 fuel that has a conductivity less than 10 conductivity units (cu) as well as in the range from 100 to 800 cu, while in the range of temperatures from 160°F down to 0°F . The range of conductivity shall be achieved through the use of fuel system conductivity additives defined in MIL-T-5624.

c. Class II Materials. The Class II conductive materials shall not produce an incendiary vapor ignition, electrical discharges, or excessive static charge build-up (electrical activity) when impinged by JP-4 fuel that has a conductivity less than 10 cu as well as in the range from 100 to 800 cu, while in the range of temperatures from 160°F down to -30°F . The range of conductivity shall be achieved through the use of fuel system conductivity additives defined in MIL-T-5624.

3.7.8 Infrared spectrum analysis. Infrared spectrum data shall be provided for the conductive material and a reference standard polyether foam.

3.7.9 Static charge dissipation test. The conductive material(s) shall be evaluated to determine the time it takes for an induced electrostatic charge to be dissipated at various temperatures including the following: 60, 32, 0, -20, -30, and $-40 \pm 5^\circ\text{F}$. The results, along with the material's electrical resistivity, shall be used to determine if an adequate rate of power dissipation can be achieved. The temperature at which the rate of power dissipation drastically drops off and approaches a zero rate in a graphical plot of the data shall be defined as the dissipation temperature limit (DTL). This DTL shall be used as the criteria for determining if the material satisfies the specification requirements for class 1 (0°) or class 2 (-30°F) materials. Example data plots as well as formulas for calculating the power dissipation from the dissipation time and electrical resistivity are provided in attachment 3 for reference. These test data and results may be substituted for the electrostatic compatibility test data in 3.7.7.

3.7.10 Electrochemical corrosion. The conductive material shall neither adhere to nor cause any pitting, erosion, or discoloration of metal plates. In addition, the material shall not produce a current flow greater than that for blue polyether foam produced in accordance with MIL-B-83054.

3.7.11 Aircraft service test. The service tested materials critical properties shall not degrade below the minimum specification requirements. The electrical resistivity shall not increase by more than two orders of magnitude from the original baseline values nor shall it exceed 5×10^{12} ohm-cm. There shall be no evidence of electrical buildup, discharge, vapor ignitions, or singeing (burning) of the foam during the service test evaluations.

MIL-F-87260(USAF)

3.7.12 Manufacturing demonstration details. The manufacturer shall successfully demonstrate that the material can be fabricated in the various standard bun sizes defined in 3.8. Hot wire is acceptable for use in final fabrication trimming of the materials provided it does not discolor the bun surfaces non-uniformly.

3.8 Dimensions and tolerances. Material shall be produced in the following standard size buns:

Grade I – 40 inches x 80 inches x 8 inches; 44 inches x 110 inches x 8 inches; 44 inches x 110 inches x 12 inches; and 44 inches x 110 inches x 4 inches.

Grade II – 44 inches x 110 inches x 8 inches; 44 inches x 110 inches x 12 inches; and 44 inches x 110 inches x 4 inches.

3.8.1 Optional bun sizes. Optional bun sizes of the material may also be produced by the manufacturer provided the following sizes are offered: 44 inches x 110 inches x 12 inches for the Grade IC and 40 inches x 80 inches x 8 inches for the Grade IIC. Manufacturing tolerance limits on bun sizes shall be as follows unless otherwise agreed to by the procuring activity and manufacturer:

- a. Width +1, -0 inch
- b. Length +1, -0 inch
- c. Height +1/8, -1/8 inch

3.9 Final product identification. On the end of each bun, a durable label card shall be attached using Dennison 3-inch loop style Swiftachment fasteners, P/N 08909 (Dennison, Fasteners Division, 888 Seventh Avenue, 13th Floor, New York, NY, 10019) or equivalent. The label card shall clearly identify the manufacturer's part number, date of manufacture, manufacturer's run number, lot number, and bun number. Where applicable, the government contract or order number shall be included. There shall be no color coding or marking on the outer surface of the bun. Each bun shall be sealed in a clean 4-mil black polyethylene bag, per L-P-378 Type I, Class I, Grade B, as it comes off the manufacturing line.

3.10 Workmanship. The material shall be fabricated in accordance with high grade manufacturing practices covering this type of material. The material shall be suitable for its intended use and free of defects which may affect its performance. It shall be of uniform color and electrical resistivity and free from excessive voids. It shall not be corrosive or deleterious to fuel systems, metals, and elastomers. Hot wire cutting may be used for the final finishing of the buns to minimize contamination.

4. QUALITY ASSURANCE PROVISIONS

4.1 Responsibility for inspection. Unless otherwise specified in the contract or purchase order, the vendor is responsible for the performance of all inspection requirements (examinations and tests) as specified herein. Except as otherwise specified in the contract or purchase order, the vendor may use his own or any other facilities suitable for the performance of the inspection requirements specified herein, unless disapproved by the Government. The Government reserves the right to perform any of the inspections or tests set forth in this specification where such inspections are deemed necessary to ensure supplies and services conform to prescribed requirements.

4.1.1 Responsibility for compliance. All items shall meet all requirements of sections 3 and 5. The inspection set forth in this specification shall become a part of the contractor's overall inspection system or quality program. The absence of any inspection requirements in the specification shall not relieve the manufacturer of the responsibility of ensuring that all products or supplies submitted to the Government for acceptance comply with all requirements of the contract. Sampling inspection, as part of manufacturing operations, is an acceptable practice to ascertain conformance to requirements, however, this does not authorize submission of known defective material, either indicated or actual, nor does it commit the Government to accept defective material.

MIL-F-87260(USAF)

4.2 Classification of tests. The inspection requirements specified herein are classified as follows:

- a. Qualification tests (4.4)
- b. Quality conformance inspection (4.5)

4.3 Test conditions

4.3.1 Temperature and humidity. Unless otherwise specified herein, all tests shall be conducted under known conditions of temperature and relative humidity. Prior to physical property testing, specimens shall be preconditioned in the test environment a minimum of 30 minutes.

4.3.2 Test fluids. Unless otherwise specified herein, the test fluids shall be of known properties and certified in accordance with the referenced military specification. The turbine fuels conforming to MIL-T-5624 and MIL-T-83133 may be obtained from the qualifying activity along with a certified test report defining, as a minimum, the specific gravity, distillation, aromatic content, existent gum, sulfur content, Reid vapor pressure (JP-4 fuel only), fuel system icing inhibitor level in accordance with MIL-I-27686, and fuel electrical conductivity level.

4.3.3 Basic property testing. Unless otherwise specified herein, all basic property tests shall be in accordance with the applicable sections specified in ASTM D3574. In the case where more than one specimen is tested, the average shall be determined. However, all values shall be reported for all but production testing. Unless otherwise specified, all sample specimens shall be tested in the dry condition. In the case where fuel-wet testing is required (special tension, tear resistance, and compression load deflection tests) the specimen should be removed from the test fluid immediately prior to property testing, drained of excess fuel, and then tested.

4.3.4 Specimen cutting. Unless otherwise specified herein, test specimen cutting shall be by die, saw cutting, or hot wire cutting.

4.4 Qualification testing. See 6.4.

4.4.1 Test sample(s). The specific bun(s) of material chosen for the qualification tests shall be typical of future production buns in terms of density and porosity (air pressure drop). Unless otherwise specified herein, this bun shall be selected from near the midrange in allowable porosity properties. Additional quantities of material will be required at the upper and lower areas of the porosity range for fluid retention, explosion suppression and flame arrestor testing.

4.4.1.1 Test specimens

4.4.1.1.1 Test section location. All test specimens shall be prepared from production material within the test section locations specified herein.

4.4.1.1.1.1 Qualification and process control tests. For qualification and process control tests, the test section shall consist of a full-size bun which has been sectioned to provide for all the qualification test samples and test specimens. All qualification test specimens used shall be from the same machine run of production material and from the specified area defined under 4.6. Where practicable, the material used shall be representative of the mid range in density and pore size (air pressure drop) for the given product.

4.4.1.1.1.2 For production and lot testing. For production and lot testing, the test section shall consist of a section approximately 15 inches long by the normal bun height and width which has been processed along with normal production material or taken from a production bun. Location of the specific test samples within the test section shall be in accordance with the guidelines specified under 4.6. Specimen measurements shall be in accordance with ASTM D3574.

4.4.1.1.2 Quantity of specimens. Unless otherwise specified herein, three specimens per sample shall be tested. The value reported shall be the average of those observed. If any value deviates more than 20.0 percent from the average value, two additional specimens shall be tested and the average for all five values shall be reported.

4.4.2 Test report, disposition of test specimens, and data for the qualifying activities. The following shall be furnished to the qualifying activities as a qualification package:

a. Test report. A qualification test report shall be prepared in accordance with MIL-STD-831 and shall include, as a minimum, the following:

(1) A tabulation of all qualification test data, including production test data on the qualification foam run. All values obtained shall be included as well as sample calculations.

(2) Detailed discussion of any failures, and retesting data.

b. Disposition of test specimens. All test specimens used in the qualification tests shall be submitted to the qualifying activity (see 6.4.1), except those subjected to the following tests:

Tension tests (4.6.5)

Tear resistance test (4.6.6)

Flammability test (4.6.11)

Steam autoclave exposure test (4.6.16)

Infrared spectrum analysis test (4.6.25)

c. Test material. In addition, the following material shall be submitted to the qualifying activity:

(1) A sample from the qualification test bun(s) or adjacent bun: Size 20 inches x 20 inches x the bun thickness.

(2) Unused retention samples (6 inches x 6 inches x 6 inches) near the bottom, middle, and top of the porosity range and corresponding porosity (air pressure drop) specimens which have been air pressure drop tested.

(3) Sufficient material (approximately four buns of Grade IC or two buns of Grade IIC) for the flame arrestor tests specified in 4.6.19.

(4) Corrosion and adhesion metal test specimens (see 4.6.20).

d. Other data. The manufacturer shall include, as a part of the report, any information defined in 6.4 that may not have been available at the time of the submittal of the letter of request for testing. Also, any applicable data or information which may relate to the qualification testing or future procurements of the material shall be included. Information referenced in 3.2.1, 3.2.2, 3.2.3, 3.2.4, and 3.5 shall also be included in the qualification test report.

4.4.3 Qualification approval. Qualification test reports shall be signed or approved by a responsible representative of the manufacturer.

4.4.4 Qualification tests. The qualification tests shall consist of all applicable tests described under 4.6.

4.5 Quality conformance inspections. Quality conformance inspections shall consist of the following tests:

a. Production tests (4.5.1)

b. Lot tests (4.5.2)

c. Process control tests (4.5.3)

d. Examination of product (4.6.1)

MIL-F-87260(USAF)

4.5.1 Production tests. Production tests shall be conducted on each run of material (see 6.4.1) produced in accordance with the following schedule:

- a. All furnished buns of material shall be visually inspected for examination of product per 4.6.1.
- b. For every 180 feet of production (or 15 buns), the following tests shall be conducted once on all products:

Color test (4.6.2)

Density test (4.6.3)

Porosity (air pressure drop) test (4.6.4)

Tensile strength and elongation tests (4.6.5)

Entrained solid contamination tests (4.6.15)

Steam autoclave exposure test (4.6.16) (See NOTE below)

Electrical resistivity (4.6.23)

NOTE: The steam autoclave exposure test specified in 4.6.16 shall be conducted only once for each machine run to verify the hydrolytic stability characteristics of the material. If the bun thickness is less than eight inches, then the entrained solid contamination test specimen should be stacked to get an eight-inch thickness.

4.5.2 Lot tests. In addition to the production tests specified in 4.5.1, the compression load deflection test specified in 4.6.8 and the fuel retention test specified in 4.6.10.1 shall be conducted on each lot (see 6.6.5) or six-month interval, whichever occurs first. The results shall be maintained on file for future reference.

4.5.2.1 Rejection and retest. Failure of any of the test specimens to conform to the applicable requirements of 3.7 and Table I shall require a retest of the property which failed on an additional set of test specimens from the same test section or from the top of the adjacent bun. Additional testing will be authorized by the qualifying activity in order to isolate the extent of defective material. In the event of failure of any of the retested specimens, the material represented by those specimens shall be rejected.

4.5.3 Process control tests. In addition to the production and lot tests, the following tests shall be conducted on production material at 12-month intervals, and the results maintained on file for future reference:

- a. Tear resistance test (4.6.6)
- b. Flammability test (4.6.11)
- c. Volume swell in JP-5 (4.6.13)
- d. Fluid immersion (wet property tests) (4.6.17.3)
- e. Electrical resistivity permanence (4.6.21)

4.5.3.1 Rejection and test. Failure of any of the test specimens to conform to the process control requirements specified herein shall require a retest of one additional set of test specimens for the property that failed from the same test section. In the event of failure of any of the retested specimens, production shall be halted and no additional material accepted until the reason for failure has been determined and corrective action taken. The qualifying activity shall be notified of any test failures encountered.

MIL-F-87260(USAF)**4.6 Test methods**

4.6.1 Examination of product. Each finished bun of material shall be visually inspected for consistency of cell structure, color, complete reticulation, obvious voids, or surface imperfections and the dimensional tolerances specified in 3.8 prior to final packaging. Criteria for rejection of buns shall be any exterior surface defects that could seriously affect the end function of the product, such as:

- a. Excessive cleaves, voids, or splits.
- b. Holes larger than 1/2 inch in diameter and 1/2 inch in depth, not to exceed four per bun and no closer together than two feet.
- c. Level of non-reticulation not to exceed 0.40 percent of the total surface area or 0.07 percent of the total volume, based on the standard size bun.

4.6.2 Color test. Testing for color shall be by visual analysis. The material shall be of a uniform color. Any unusual color variations over the foam surface shall be cause for rejection, especially distinct surface darkening due to dirt, contamination, or surface deterioration or any color mottling. The color of the product is not limited except that it shall not be blue, orange, yellow, or red.

4.6.3 Density test. One test specimen shall be tested in accordance with ASTM D3574 (Test A). Specimen size shall be 3 inches x 7 inches x 10 inches, such that the 3-inch dimension is in the direction of the width (see 6.6.2) and the 7-inch dimension is in the direction of rise (6.6.3) of the test section. The results shall be reported to the nearest 0.1 pound per cubic foot (lb/ft³).

4.6.3.1 Density uniformity. The density uniformity of the product shall be demonstrated during qualification testing by sampling a bun of product at a minimum of ten locations throughout the bun (height) top and bottom and tested for density per 4.6.3. The specimen size shall be 3 inches x 4 inches x 10 inches. The 4-inch dimension shall be in the height direction. The density variation shall be determined and all values reported for both buns of material.

4.6.4 Porosity (air pressure drop) test. The pore size determination shall be by the air pressure drop technique specified herein. Two specimens per sample shall be run for production tests and three specimens per sample for qualification tests. The cylindrical specimen shall be 10 inches in diameter by 1 ± 0.02 inch thick, where the one inch dimension is in the height direction of the test section. For production tests the porosity test specimen shall be taken with the top and bottom three inches of the test section. For qualification testing, the three specimens shall be taken from the same location but from the upper, middle, and lower portions of the bun height. *Pressure drop measurements shall be made using a porosity test rig (see Figure 1) which has been properly calibrated.* Calibration shall be conducted on a daily basis using either a special pressure drop screen or orifice plate in order to determine the reference setting for the orifice differential manometer, or a correction factor that accounts for density variations of the air. Prior to sample testing, the manometer which indicates the air flow shall be adjusted to zero with no airflow. The specimen shall then be inserted into the sample holder until it is properly seated into the cutout. The blower shall be started and the airflow set to coincide with the daily reference calibration setting on the orifice differential manometer. Next, read the sample pressure drop (uncorrected) to the nearest 0.005 inch on the 4-inch manometer (designated sample differential). The value shall then be corrected for thickness (if other than 1.00 inch thickness) by dividing it by the measured sample thickness. This corrected air pressure drop shall then be compared to the porosity curve (Figure 2) in order to determine the average pore size for the sample specimens. The sample pressure drop shall be reported. NOTE: The porosity values shown on Figure 2 are assigned for reference only and do not necessarily relate directly to the actual number of pores per lineal inch.

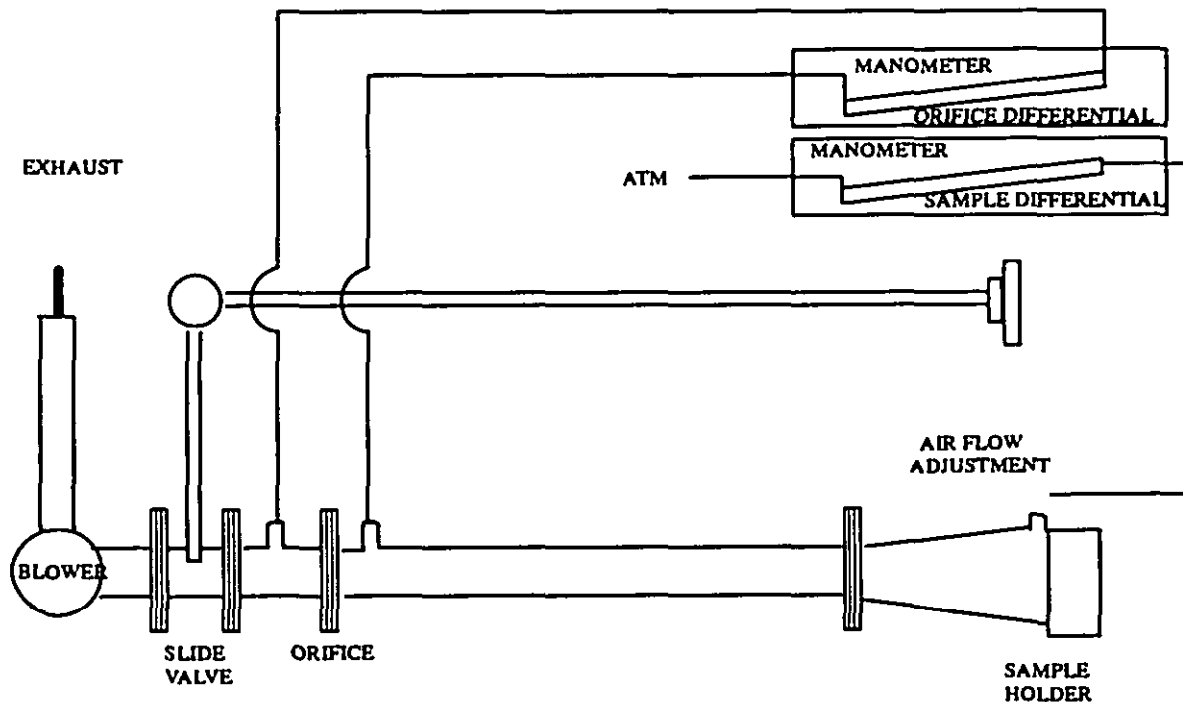

FIGURE 1. Typical porosity (air flow) test apparatus.

4.6.5 Tensile strength and ultimate elongation tests. Tension tests, including tensile strength and ultimate elongation, shall be conducted in accordance with ASTM D3574 (Test E), except that the initial jaw separation shall be 2.0 inches. A 2.5-inch jaw separation may be used for consistency with other products, however, data must be provided in the qualification report showing the correlation between the two grip lengths. For elongation measurements there are two approved techniques, benchmarks and crosshead travel. The rate of travel of the power actuated grip shall be 20 ± 1 inch(es) per minute and shall be uniform at all times. The specimen die to be used shall be in accordance with the Figure 1 of ASTM D3574 entitled "Die For Stamping Tension Specimens". The approximate size of the dry specimen shall be 5.5 inches x 1 inch x 0.50 inch thick. The specimen thickness dimension shall be between 0.500 and 0.600 inches. For all but qualification, three specimens per sample shall be tested. If any value deviates more than 20.0 percent from the average, two additional specimens shall be tested and the average of all five reported. For qualification, 10 specimens shall be tested and all values reported. In addition, a copy of the recorded traces shall be included in the test report. The tensile strength shall be reported in pounds per square inch, and ultimate elongation in percent. Tension specimens shall be taken from the upper half of the test section, and the orientation shall be such that the 1/2-inch dimension (5.5 inches) is always in the machine direction (see 6.6.4). For special fuel-wet tension tests, the specimens shall be measured on the dry specimen prior to test fluid exposure and recorded for later usage. When testing the specimen, it should be removed from the fluid prior to tension tests, drained, and immediately tested. Do not allow the sample to air dry, as it will affect the test results. Original dry specimen data shall be used as a baseline for calculating the percent loss in wet tensile strength for tests in 4.6.17b.

4.6.6 Tear resistance test. Three specimens shall be tested in accordance with ASTM D3574 (Test F) using a crosshead speed of 20 ± 1 inch(es) per minute. Dry specimen size shall be 6 inches x 1 inch x 1 inch where the 6-inch dimension is in the machine direction and the slit cut is parallel to the direction of rise. The tear resistance shall be reported in pounds per lineal inch of thickness. Specimens shall be cut from one inch thick slabs of material. For fuel-wet tear resistance tests (4.6.17b), the specimen shall be tested immediately after removal from the fluid. Original dry specimen data shall be used as a baseline for calculating the percent loss in wet tear resistance.

MIL-F-87260(USAF)

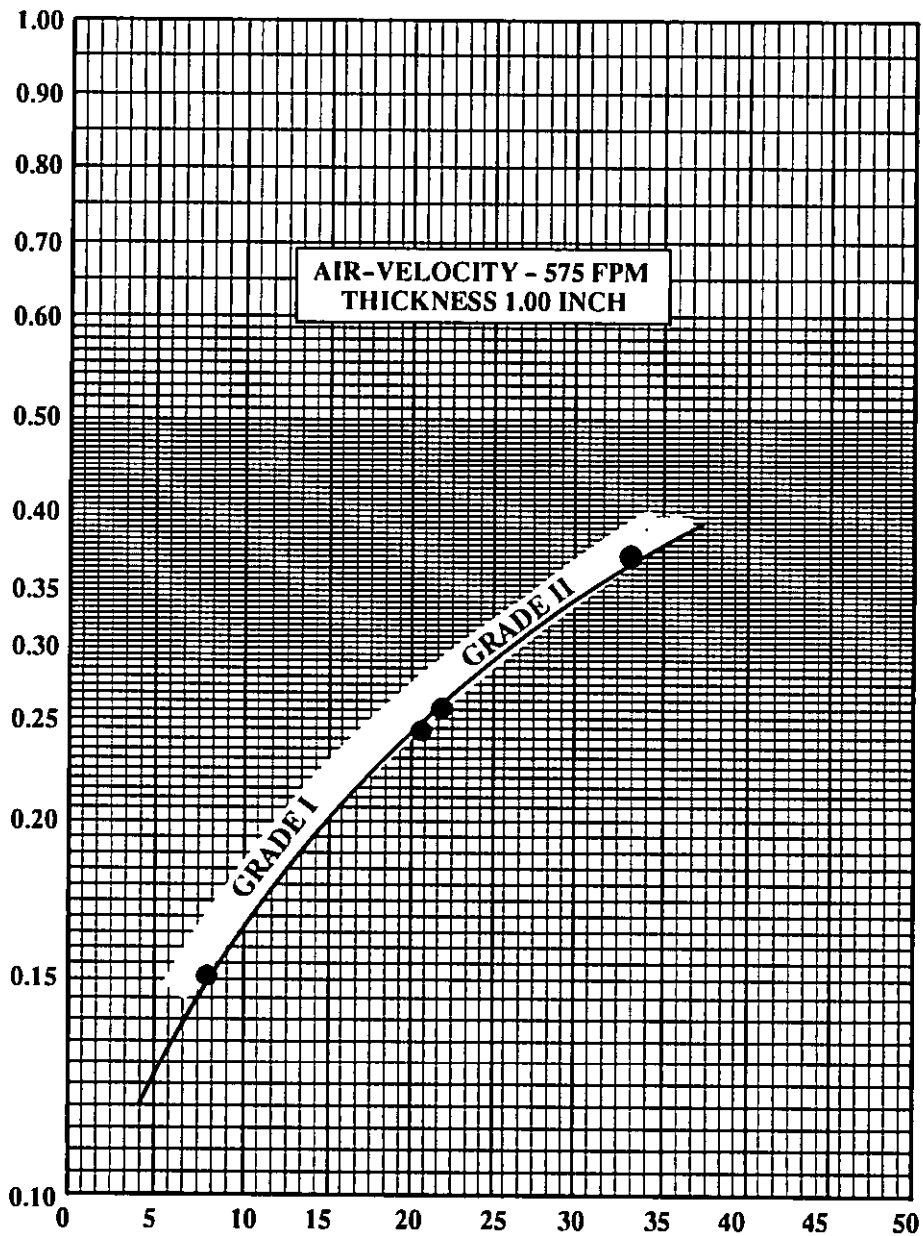

FIGURE 2. Porosity curve.

4.6.7 Constant deflection compression set test. Three specimens shall be tested in accordance with method B of ASTM D3574 (test D) at a 50 percent deflection. Sample size shall be 4 inches x 4 inches x 3 inches. The three specimens shall be cut from the same 3-inch thick slab located in the middle of the test section (bun) height and adjacent to the specimens used in the compression load deflection test specified in 4.6.8. The specimens shall be tested (compressed) in the direction of rise (3-inch dimension). Results for all specimens shall be reported in percent of original thickness.

4.6.8 Compression load deflection (CLD) test. Three specimens shall be tested in accordance with ASTM D3574 (test C) at the 25 percent and 65 percent deflection level after 1 minute at each deflection point. Specimen size shall be 4 inches x 4 inches x 3 inches and taken near the middle of the bun height such that the 3-inch dimension is in the direction of material rise. The rate of compression (deflection) shall be two inches per minute. New material shall be aged for a minimum of 96 hours following thermal reticulation prior to compression load deflection testing. Tests shall be conducted in the direction of material rise. Prior to testing, the specimens shall be preflexed twice to 80 percent compression. A copy of the recorded traces for each test shall be included in the test report and results reported in pounds per square inch. For wet compression load deflection properties the test specimen shall be tested immediately after removal from the fluid. The original dry specimen data shall be used as a baseline for determining the percent loss in wet compression load deflection properties per 4.6.17b.

4.6.9 Fuel displacement test. One sample per test shall be run using grade JP-5 or JP-8 turbine fuel conforming to MIL-T-5624 or MIL-T-83133 respectively, and the average reported as the fuel displacement. The test shall be conducted at standard conditions using a standard 1,000 milliliters (ml) capacity cylinder having 10 to 20 ml graduations. Each specimen shall be cut into a cylindrical shape having a diameter approximately equal to that of the graduated cylinder and a length sufficient to fill the test cylinder to the 900 ml mark. Specimens shall be cut in the direction of the material rise (bun height). Fuel shall be added to the 900 ml mark in the graduated cylinder and the specimen slowly added until it is completely immersed. The specimen shall be immersed for a period of 24 hours to obtain maximum swelling effects. The new fluid level shall be noted and the increase in milliliters shall be recorded. The size of each specimen shall be measured and recorded. The displacement shall be calculated as follows:

$$\text{Percent Volume Displacement} = \frac{\text{millileters increase} \times 100}{\text{original fluid volume}}$$

4.6.9.1 Theoretical fuel displacement. The theoretical volume displacement of the material as calculated from the following formula and based on the material density specified in 4.6.3 shall be reported:

$$\text{Percent displacement(vol)} = \frac{\text{material density (lbs/ft}^3\text{)} \times 100}{\text{density of poplyol(s) polymer (lbs/ft}^3\text{)}}$$

4.6.10 Fuel and water retention tests

4.6.10.1 Fuel retention tests. Fuel retention shall be determined on a 6 inches x 6 inches x 6 inches specimen using grade JP-5 or JP-8 turbine fuel conforming to MIL-T-5624 or MIL-T-83133 respectively, having a specific gravity of 0.788 to 0.845. For qualification testing the retention values shall be determined throughout the porosity range of the product and the data plotted as a function of air pressure drop. A minimum of three different retention specimens at three different porosity locations (lower, middle, and upper porosity ranges) shall be tested for each type of material. At each test location four retention specimens shall be cut from the center of the respective test section (bun) height directly adjacent to each other. These shall be identified at the top surface, and two each shall be identified for the fuel retention test specified herein and the water retention test specified in 4.6.10.2. A porosity test specimen shall be taken directly above and below the retention specimen and tested per 4.6.4. All retention and porosity (air pressure drop) specimens shall be properly labeled on the top surface and submitted to the coordinating activity. One fuel retention specimen from each of the three test locations shall be tested in accordance with the following procedure, and all applicable data shall be recorded:

a. The specimen shall be preconditioned at a temperature of $75 \pm 5^\circ\text{F}$ for a minimum of 30 minutes, weighed to the nearest 0.1 gram, and the dimensions measured in accordance with ASTM D3574. The test fluid shall be prefiltered

MIL-F-87260(USAF)

through a 0.8-micron filter as specified in 4.6.15 and then adequately preconditioned at the test temperature. Just prior to use, the fluid shall be tested for specific gravity (density) and temperature.

b. The retention test apparatus shall be sized to approximately 7 inches x 7 inches x 10 inches and shall have a means of draining the fuel from the bottom at the rate of 500 ± 50 cc/minute. The draining drop rate in this particular apparatus should approximate 0.5 inch per minute. The test fluid shall be charged into the container to a level which corresponds to approximately 0.5 inch above the top of the specimen.

c. The specimen shall then be slowly placed into the container such that the specimen is oriented in the direction of rise (bun height) and supported off the bottom of the container by two glass rods and spaced 0.5 inch from all sides of the container. Fuel shall then be drained at the prescribed rate until flow ceases and the specimen then allowed to drain in this position for an additional two minutes.

d. The specimen shall then be carefully removed from the container and weighed to the nearest 0.1 gram. Care should be taken not to spill the fluid from the bottom surface of the specimen when removing from the test rig. Using the specimen weights before and after fluid-wetting in grams, specimen volume in cubic centimeters, and fuel density in grams per cubic centimeter, the percent volume retention shall be calculated as follows:

$$\text{Percent retention} = \frac{(\text{wet spec. wt} - \text{dry spec. wt}) \times 100}{\text{specimen volume} \times \text{density of fuel}}$$

e. All values, including test fluid temperature and porosity values (top/bottom), shall be reported. The above procedure shall then be repeated, using the same specimens, and report results.

4.6.10.2 Water retention test. Using one unused water retention specimen specified in 4.6.10.1, the volume percent retention shall be determined using the same procedure. This shall be repeated for at least one other porosity location. The test fluid shall be unused distilled water which has been tested for temperature and density just prior to use. CAUTION: Do not run more than two tests per batch of water.

4.6.10.3 Test data and sample requirements. Report test data on all samples tested including the air pressure drop of the specimens directly above and below the retention samples. A minimum of three specimens from various locations within the porosity range for a material shall be evaluated and a curve of fuel retention versus air pressure drop established. The data (curve) shall be extrapolated to the upper air pressure drop limit and the projected fuel retention limit shall be established and reported. A fuel retention sample for each data point along with the tested porosity samples shall be identified and submitted to the qualifying activity (see 6.4.1).

4.6.11 Flammability test. Five specimens shall be tested in accordance with the procedure specified in Appendix B. Specimen size shall be 6 inches x 2 inches x 1/2 inch. Flammability specimens shall be taken from the upper half of the test section, and the orientation shall be such that the 6-inch dimension is in the machine direction (length) and the 1/2-inch dimension is in the direction of rise (height). All test values shall be reported and the average flammability shall be calculated in inches per minute.

4.6.12 Extractable material test. The extractable material test shall be conducted on one test specimen. The specimen size shall be 1 inch x 1 inch x 2 inches and cut by means of a saw or die. Preconditioning of the specimen shall include drying at $200 \pm 5^\circ\text{F}$ for 15 minutes and cooling the specimen in a desiccator for a minimum of 30 minutes. Immediately following the preconditioning, the specimen shall be weighed to the nearest 0.10 milligram. The specimen shall then be placed in a 60 ml volume Soxhlet extraction tube which is connected to a water-jacketed condenser. Several standard boiling stones and 125 ml of Type III test fluid conforming to TT-S-735 shall be added to a 250 ml Florence flask and the flask attached to the extraction tube. The heating unit shall be activated and the fluid allowed to reflux for a period of three hours. Following reflux, the specimen shall be removed, dried at $200 \pm 5^\circ\text{F}$ for 15 minutes, cooled in a desiccator for 30 minutes and then weighed. The percentage of extractable material shall be calculated as follows:

MIL-F-87260(USAF)

$$\text{Percent extractable} = \frac{(\text{orig. specimen weight} - \text{full weight}) \times 100}{\text{original specimen weight}}$$

4.6.13 Volume swell test. One specimen for each test fluid shall be tested for volume changes after immersion for 7 days at $75 \pm 5^\circ\text{F}$ in Type I test fluid conforming to TT-S-735, Type III test fluid conforming to TT-S-735, and grade JP-4, JP-5 conforming to MIL-T-5624, and JP-8 turbine fuel conforming to MIL-T-83133. Sample size shall be 6 inches x 6 inches x 6 inches. The samples shall be taken from the same approximate location in the test section as the retention test specimens specified in 4.6.10. Dry and wet measurements shall be made on the test specimens in accordance with ASTM D3574. Following immersion, the specimens shall be removed and immediately measured wet for the final volume. All values for the specimen including original and wet volumes shall be reported and the percent volume increase from the original and wet measurements shall be calculated.

4.6.14 Low temperature flexibility test. Three specimens, 2 inches x 1/2 inch x 12 inches shall be preconditioned in air along with a 3-inch diameter rod to a temperature of $-55 \pm 5^\circ\text{F}$ for one hour. Each specimen shall be cut such that the 12-inch dimension is in the machine direction. At the end of the conditioning period and without removing the specimens from the chamber, each specimen shall be bent around the rod. Any evidence of breaking or cracking of foam strands shall be cause for failure.

4.6.15 Entrained solid contamination tests. Solid contamination tests shall be conducted on a hot-wire-cut cylindrical specimen having dimensions of 9.25 inches in diameter and 8 inches in height. The 8-inch dimension shall be cut in the direction of rise (bun height). For material having more than 8 inches in bun height, the specimen shall be taken from the lower portion of the test section. Testing shall be conducted using a U.S. Testing Company model 6523 dry cleaning machine or equivalent, having a tumbler rotation speed of 45 rpm. The specimen shall be positioned in the center of the tumbler. The test cycle shall be 5 minutes using a 4-liter charge of Type I fluid conforming to TT-S-735 which has been pre-filtered through a 0.8-micron Millipore Filter Corporation filter, or equivalent. Upon completion of the test cycle, the specimen shall be positioned slightly above the fluid level and allowed to drain for five minutes prior to removal. The test fluid shall then be tested for level of solid contamination in accordance with ASTM D2276, Appendix A3 (laboratory filtration) or T.O. 42B-1-1, Sections 5-23, 5-24, and 5-47 through 5-52. Following filtration of the test fluid and just prior to removal of the filter pad from the apparatus, the filter and contamination shall be neutralized of static charge with a Nuclear Products Company Model 2U500 air deionizer, or equivalent (see 6.9). This step reduces the loss of particles from the filter pad during transfer to the drying oven. Each filter used shall be dried at $200 \pm 5^\circ\text{F}$ for a minimum of 15 minutes and then cooled for a minimum of 15 minutes. A minimum of one control filter shall be run for each set of samples. Test results shall be reported in milligrams per cubic foot of material.

4.6.16 Steam autoclave exposure test. Testing shall be conducted in accordance with ASTM D3574 (test J) steam autoclave test for 10 hours at $250 \pm 5^\circ\text{F}$. Tension tests as specified in 4.6.5 shall be conducted on five control specimens and five exposed specimens. Prior to testing, exposed specimens shall be post-dried for 30 minutes at $160 \pm 5^\circ\text{F}$ and then cooled at room temperature for 30 minutes. The results for tensile strength and elongation shall be reported before and after exposure and the average percent change in tensile strength calculated.

4.6.17 Fluid immersion tests. Fluid exposure tests, shall be conducted on the baffle material under the following exposure conditions:

a. Grade JP-4 turbine fuel conforming to MIL-T-5624 for 12 weeks at $160 \pm 5^\circ\text{F}$. Tension and Electrical Resistivity Specimens, per 4.6.5 and 4.6.4 respectively, shall also be exposed to the test environment.

b. Grade JP-4 turbine fuel conforming to MIL-T-5624 for 4 weeks at $75 \pm 5^\circ\text{F}$. To determine the wet property values for the material, tension, CLD, and tear resistance specimens, per 4.6.5, 4.6.8, and 4.6.6 respectively, shall be exposed to the test environment, and then tested fuel-wetted for all properties.

4.6.17.1 Tension tests. Tests in accordance with 4.6.17a shall be conducted in loosely capped standard quart jars using approximately 900 ± 25 ml of fluid for each nine specimens for each sampling frequency. Specimens shall be taken from the upper half of the test section as specified in 4.6.5. The testing frequency for each condition shall be every four weeks. The JP-4 fuel shall be changed at each four-week interval. Testing shall include three specimens dry tension-tested as specified in 4.6.5, three specimens tested in accordance with the steam autoclave exposure test as specified in 4.6.16, and three additional specimens shall be tension-tested while fuel-wetted in accordance with 4.6.5. Prior to dry tension and steam autoclave testing, the specimens shall be rinsed in petroleum ether, dried for 30 minutes at $160 \pm 5^\circ\text{F}$, and cooled at room temperature. Wet tension tests shall be run immediately after removal from the test fluid. All values for original, final (dry and wet), and percent change of tension properties shall be reported. The wet tensile property change shall be calculated using the initial (time = 0) wet tension values as a baseline.

4.6.17.2 Electrical resistivity test. In addition to the tension tests of 4.6.17.1 electrical resistivity tests shall be conducted using specimens defined in 4.6.4. A total of six specimens shall be exposed to the fuel and at each two-week interval a specimen shall be removed, washed in petroleum ether, dried, and then tested per 4.6.23. The specimens shall also be tested initially, prior to immersion into the fuel. At each four-week interval the fuel shall be changed. All values for original and final electrical resistivity shall be reported along with the test conditions (temperature and humidity) that existed during the electrical resistivity tests. The electrical resistivity tests shall be in accordance with the procedures for production specimens defined in 4.6.23.

4.6.17.3 Immersion tests. Fuel (JP-4) immersion tests in accordance with 4.6.17b shall be accomplished in containers sufficient to provide complete immersion for all tension, CLD, and tear specimens. Following the 4-week exposure at $75 \pm 5^\circ\text{F}$ (room temperature), three specimens shall be immediately tested for wet tension properties in accordance with 4.6.5, wet CLD properties in accordance with 4.6.8, and wet tear resistance properties in accordance with 4.6.6. All values and averages shall be reported and the percent change from the original dry test properties shall be calculated. The original dry property data determined in 4.6.5, 4.6.8, and 4.6.6 should be used to establish the percent change in properties due to fuel-wetting.

4.6.18 Hydrolytic stability tests. The following tests shall be conducted to characterize the hydrolytic stability of the material:

4.6.18.1 Humidity exposure. Tension and electrical resistivity specimens shall be exposed to $200 \pm 5^\circ\text{F}$ and 95 \pm 5 percent relative humidity for 12 weeks or until failure, whichever occurs first.

4.6.18.1.1 Tension tests. Tension tests shall be conducted in loosely capped standard glass quart jars using 50 mls of distilled water for each 900 mls of container volume and a maximum of nine tension specimens for each sampling jar. Specimens shall be supported above the water and the water level shall be maintained throughout the test. A minimum of three specimens for each exposure time shall be tensile tested. In addition, electrical resistivity tests shall be conducted using specimens defined in 4.6.4. Sufficient specimens shall be used to allow samples to be removed at least once a week in order to determine the failure point for the conductive treatment or coating. All resistivity specimens shall be measured initially (prior to exposure) to establish property changes due to testing. The test specimens shall be removed, drained free of water, blotted dry, and then air dried at $160 \pm 5^\circ\text{F}$ for a minimum of 30 minutes prior to any preconditioning for resistivity evaluations. The resistivity specimens shall then be tested (following preconditioning) in accordance with 4.6.23. Water used in the containers shall be maintained and changed on a weekly basis. All values for original and final electrical resistivity shall be reported along with the test conditions (temperature/percent relative humidity) that the specimens were exposed to during the resistivity measurements.

4.6.18.2 Water immersion. Tension specimens shall be immersed in pure distilled water at $160 \pm 5^\circ\text{F}$ for 12 weeks or until failure.

4.6.18.2.1 Testing frequency. Testing frequency and water changes shall be at four-week intervals. Three specimens shall be tested for each sampling frequency. Testing shall be conducted in loosely capped jars using 900 ± 25 mls of water for each of the nine tension specimens. Water used in the containers shall be changed on a weekly basis.

MIL-F-87260(USAF)

4.6.18.3 Dry heat. Tension and electrical resistivity specimens shall be exposed to dry heat at $250 \pm 5^\circ\text{F}$ for eight weeks or until failure.

4.6.18.3.1 Testing frequency. The testing frequency shall be at two-week intervals. A minimum of three tension specimens shall be tested for each sampling frequency. Additional specimens shall be exposed for electrical resistivity evaluations. The specimens shall be in accordance with 4.6.4 and shall be tested, as a minimum, on a weekly basis. Prior to the start of the test, the electrical resistivity specimens shall be tested and the test conditions recorded per 4.6.23. All test data shall be reported including test conditions (temperature/relative humidity) for the electrical resistivity evaluations.

4.6.18.4 Data requirements. All tension and electrical resistivity test data obtained under 4.6.18 shall be reported per 4.6.5 as well as percent loss in tensile strength. In addition, the tensile strength and electrical resistivity values shall be plotted as a function of exposure time.

4.6.19 Explosion suppression and flame arrestor characteristics. The explosion suppression and flame arrestor characteristics of the material shall be defined using a small scale flame tube type apparatus having a minimum total volume of 5 cubic feet and a 100 square inch cross-sectional area. The following parameters shall be satisfied in all the testing:

- a. Stoichiometric propane/air mixture (4.5 to 5.2 volume percent propane) verified by bomb sampling
- b. Spark ignition source having a minimum of 0.25 millijoules energy
- c. Dry arrestor material
- d. Minimum instrumentation shall include: pressure rise, combustion temperature indication, and visual, photographic, or photocell indication of flame penetration downstream of arrestor.
- e. Combustion relief area shall be 80.0 percent of cross-sectional area or greater. The material used for the testing shall be taken from a given bun which has been sufficiently tested to establish its air pressure drop (porosity) and density characteristics. The material shall always be oriented in the test apparatus to permit flame penetration in the direction of porosity testing (direction of rise or bun height).
- f. Where practical, the material used shall be in the lower half of the air pressure drop range. For example: Grade I shall be between 0.150 and 0.200 inch of water and Grade II shall be between 0.260 and 0.310 inch of water.

4.6.19.1 Material sizing. The material shall always be slightly oversized, 2.0 percent maximum, when installed and restraints used to avoid arrestor movement during testing. The combustible mixture on each test shall be verified by bomb sampling and shall meet the following minimum criteria for pressure rise:

$$\Delta P_{\text{min}} = (3P_0) \times 0.7, \text{ where } P_0 = \text{initial pressure of system in psia.}$$

The following definitions shall apply (see Figure 3).

psid = differential pressure rise starting point maximum overpressure point during the combustion process

V_a = arrestor volume

V_c = combustion (ignition volume)

V_r = relief volume = $V_a + V_c$

V_t = total volume of apparatus = $V_c + V_r$

V_v = void volume downstream of arrestor

T_m = minimum arrestor thickness required prevent flame propagation V_c to V_r

MIL-F-87260(USAF)

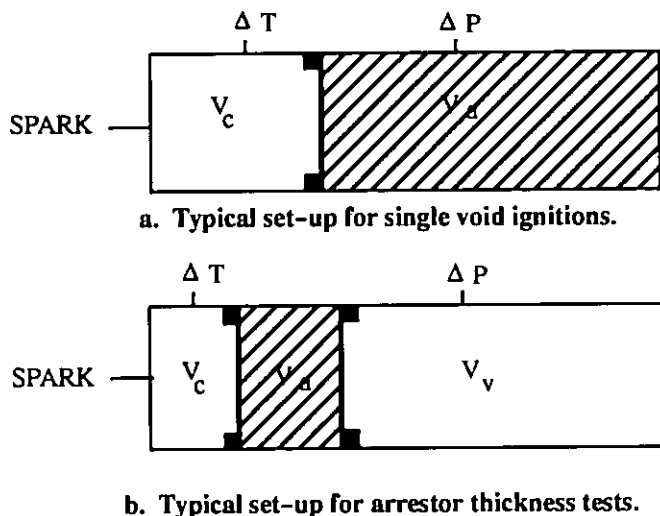

FIGURE 3. Flame arrester apparatus.

4.6.19.2 Additional tests. The following testing shall be conducted and all data shall be reported for each test condition (see Figure 3 for typical flame arrester orientation).

4.6.19.2.1 Single void ignitions. Single void ignitions shall be conducted at 3 psig (17.7 psia) initial pressure with the following minimum number of percent combustion volumes (percent V_v) of:

- a. Grade I: 10, 15, 20, and 30 volume percent
- b. Grade II: 20, 30, 35, and 40 volume percent

A minimum of two tests shall be conducted for a given condition and all data such as bomb sample and system pressure rise, test temperature, extent and location of arrester damage, and any other related information shall be submitted to the coordinating activity. A plot of pressure rise (psid) versus (percent) combustion volume shall be submitted for each initial pressure condition. Repeat test may be conducted on the material provided the damaged (burned) arrester is replaced after each test. All tests shall be conducted at standard laboratory conditions.

4.6.19.2.2 For Grade II (fine pore material only). Determine the amount of arrester (thickness) required to prevent flame propagation from V_c to V_v when the combustion volume (V_c) is 9.1 and 16.7 volume percent and the initial pressures are 0 and 3 psig. Testing shall be conducted at one inch (thickness) intervals until the minimum arrester thickness (T_m) is determined. Then a minimum of two tests shall be conducted to verify the minimum thickness. All data including system and bomb pressure rise, test temperatures, extent and location of arrester damage, and any other related information shall be reported. The ratio of arrester volume to combustion volume (V_a/V_c) shall be calculated for each minimum arrester thickness (T_m).

4.6.20 Corrosion and adhesion test. One 4-inch by 3-inch specimen cut such that the 4-inch dimension is in the direction of material rise shall be exposed in contact with 7075 aluminum alloy per QQ-A-250/12 for 14 days at $75 \pm 5^\circ\text{F}$ (room temperature) and 95 ± 5 percent relative humidity. Color photographs shall be taken of all specimens and plates both before and after exposure.

4.6.20.1 Roughness test. Three sets of metallic plates shall be used having a surface finish of 5–15 micro-inches obtained by lapping. The roughness shall be determined by a profilometer or equivalent instrument. The roughness reading is the arithmetical average of the deviations in the surface expressed in micro-inches measured normal to the surface. For these tests the surface finish should be prepared per 4.6.20.1.1.

MIL-F-87260(USAF)

4.6.20.1.1 Surface finish. A surface finish of 5-15 micro-inches measured perpendicular to the lay at a roughness-width cutoff rating of 0.030 inch and a maximum roughness-width rating of 0.015 inch. One set shall be clamped together with the baffle material specimen such that the baffle material is compressed from 4 to 3 inches in thickness in contact with the polished surfaces. This set along with one set of extra plates (controls) shall then be exposed for 14 days at room temperature and 95 ± 5 percent relative humidity in a sealed container or humidity cabinet. In addition, the third set of plates shall be used to run a comparison test on the vendor's basic blue polyether foam having the same porosity as the conductive material. Test specimens should be oriented such that the metal plates are vertical in order to minimize moisture condensation and pooling on the plate surfaces. At the termination of the test, there shall be no adhesion of the baffle material to the metal plates nor shall there be any evidence of pitting, erosion, corrosion, or bad discoloration as a result of the material contact, as determined by the following procedures. The basis for the comparison shall be the exposed set of control plates.

a. The surfaces of the plates which were in contact with the material shall be inspected for such things as discoloration, deposits, and pitting. If any of these conditions exists, the surface of the plates shall be washed in precipitation naphtha. Deposits determined as urethane materials or elements, which can be removed by this process, shall be construed as adhesion.

b. If any other marks remain on the surface of the plates after being washed in precipitation naphtha as specified in 4.6.20.1.1 a, the surfaces shall be lightly polished with a nonabrasive cloth buff. Any pits or eroded marks remaining after this process shall be construed to be corrosion. Discoloration or staining (marks which do not physically affect the surface of the plates and which easily wash or buff off) shall not be considered detrimental.

4.6.20.2 Test report. All test data, including the photographs, shall be included in the test report. In addition the test plates shall also be submitted to the qualifying activity.

4.6.21 Electrical resistivity permanence

4.6.21.1 Water immersion. Electrical resistivity specimens, per 4.6.4, shall be immersed in pure distilled water at $120 \pm 5^\circ\text{F}$ for 12 weeks or until failure. The same 12-week exposure at $160 \pm 5^\circ\text{F}$ may be substituted for this temperature (see 4.6.18.2). For process control testing, the test time may be reduced to four weeks.

4.6.21.1.1 Electrical resistivity specimens. Sufficient electrical resistivity specimens shall be included to allow for specimen removal at least twice a week. The specimens shall be tested for initial resistivity prior to water exposure to establish a baseline. At least one specimen shall be removed from the test environment twice weekly, and upon removal it shall be dried at $160 \pm 5^\circ\text{F}$ until dry and then preconditioned to the laboratory conditions for at least 30 minutes. Following preconditioning, the specimen shall be tested per 4.6.23 and reinserted into the test environment. The distilled water shall be replaced on a weekly basis. All initial and final electrical resistivities shall be reported, as well as all test conditions (temperature and humidity) during resistivity measurements.

4.6.22 Fuel compatibility test. MIL-T-5624 (grade JP-4) and MIL-T-83133, (grade JP-8) fuels shall be exposed to the conductive material for four weeks at $75 \pm 5^\circ\text{F}$ and then tested for the properties listed below. The fuels shall also be tested prior to the exposure as indicated. The ratio of conductive material to fuel shall be approximately 1:1. The foam color/pigment change (loss) shall be documented following exposure to verify the requirement of section 3.4.

<u>Fuel property</u>	<u>Control Test</u>	<u>After Exposure</u>
a. Saybolt color	YES	YES
b. Total acid number	YES	YES
c. Aromatics and olefins	YES	NO
d. Mercaptan sulfur and total	YES	NO
e. Distillation	YES	NO
f. Density	YES	NO

MIL-F-87260(USAF)

g. Vapor pressure (JP-4 only)	YES	NO
h. Copper strip corrosion	YES	YES
i. Thermal stability	YES	YES
j. Existent gum	YES	YES
k. Filtration time	YES	YES
l. Water reaction	YES	YES
m. Water separation (may use MicroSep or MiniSonic in place of WSIM)	YES	YES
n. Fuel electrical conductivity	YES	YES

4.6.23 Electrical resistivity test. All volume resistivity measurements of the conductive material shall be conducted in accordance with the basic requirements of ASTM D257. A standard set of electrodes shall be used for all measurements and shall be constructed from stainless steel in accordance with the guidelines of Figure 4. The measurements shall be made on qualification and production specimens per 4.6.4, and on full size buns through the bun thickness. For qualification, the resistivity and resistivity uniformity shall be established by evaluating a standard bun of the finished material at several locations (four minimum) by using production specimens, per 4.6.4, from various positions in the bun (top, middle, bottom of the bun height). For production tests, the resistivity specimens shall be taken from the top, middle, and bottom three inches of the test section (per 4.6.4). Qualification and production specimens shall be tested at standard laboratory conditions. The full size bun measurements may be conducted in the manufacturing area after final trimming has been accomplished, with temperature and humidity recorded. These measurements shall be conducted without cutting the bun, but by measuring the resistance through the bun thickness. The electrical resistivity values shall then be extrapolated to standard conditions ($75 \pm 5^\circ\text{F}$, 55 ± 5 percent relative humidity). The extrapolation shall be accomplished with a calibration curve(s) for the product as a function of relative humidity (see 4.6.23.3 for the required correlation data).

4.6.23.1 Test equipment and preconditioning environment. A suggested electrical resistivity test set-up employs a Beckman Megohmmeter Model L-8 (or equivalent) with a variable resistance (10^6 to 10^{13} ohms) and a variable supply voltage (1-1000 volts), in combination with the stainless steel electrodes on Figure 4. The production test specimen size shall be the same as that for air pressure drop (see 4.6.4) and shall be taken from the same locations (top, middle, bottom). One set may be used for both air pressure drop and electrical resistivity. If the resistance of the one inch test specimen is below the lower limit (10^6 ohms) of the megohmmeter being used it may be necessary to use more than one specimen. By stacking 2 or 3 one-inch thick specimens together a value of resistance may be obtained that can be measured on the meter. Production tests shall be conducted in a laboratory environment following a minimum of one hour of preconditioning in the test environment. For full size bun testing, the bun should also be preconditioned for at least one hour prior to testing, and the temperature and humidity in the production test location recorded along with the measured resistance and calculated resistivity.

4.6.23.2 Test procedure and calculation. The test equipment (electrodes/megohmmeter) shall be set up as shown on Figure 4 with the test sample (specimen or bun) placed between the electrodes and the electrodes centered directly over each other to produce a vertical "field" between the plates. The megohmmeter voltage shall be set to 500 volts and the variable resistance adjusted until a steady-state resistance reading is obtained on the meter. Allow the meter to stabilize for one minute and record the resistance for the specimen along with the temperature, relative humidity, and the thickness of the specimen. Calculate the sample volume resistivity as follows:

$$ev = \frac{\text{measured resistance (ohms)} \times 155.7 \text{ (cm}^2\text{)}}{\text{sample thickness (inches)} \times 2.54 \text{ (cm/in)}}$$

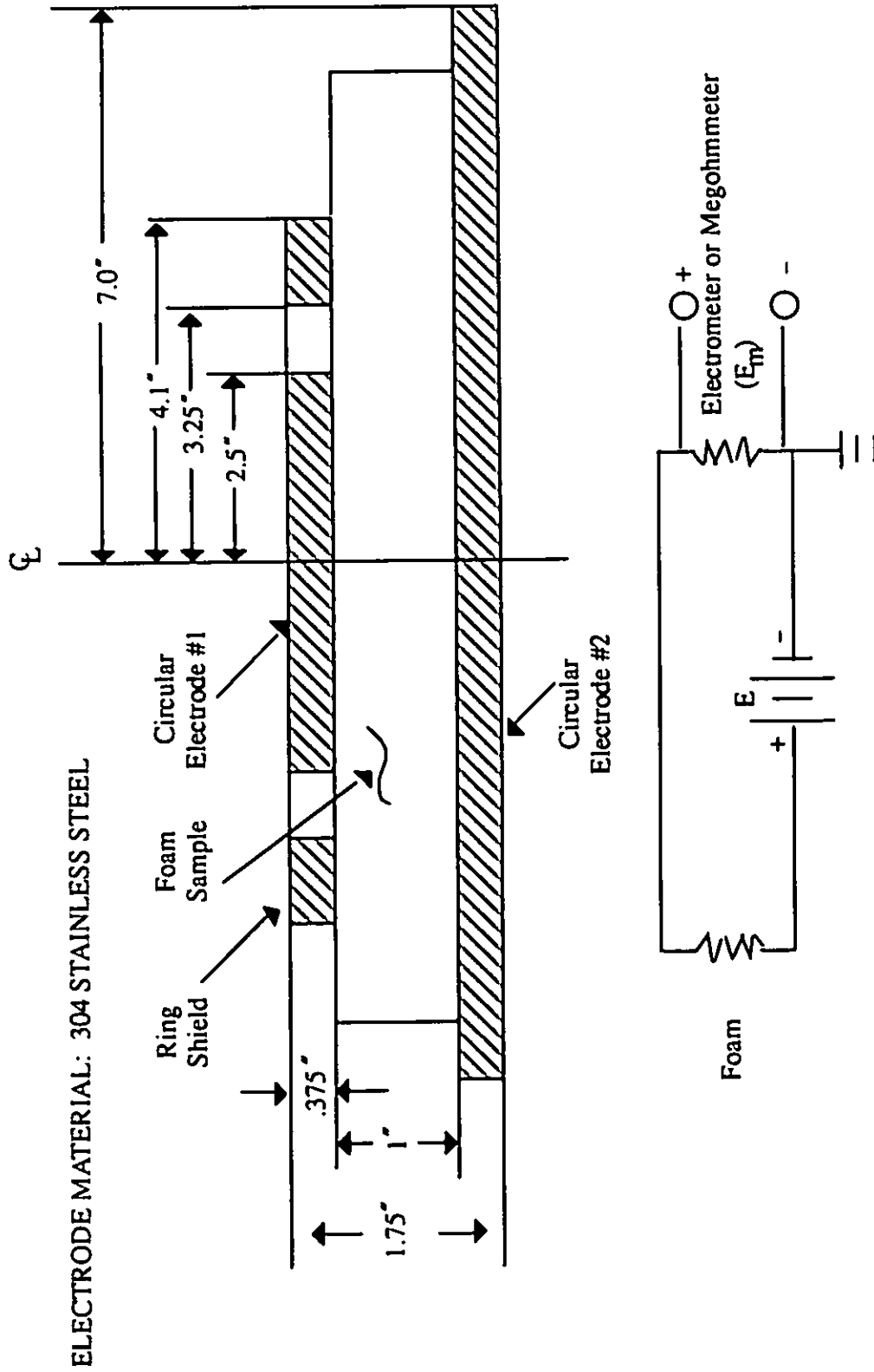

FIGURE 4. Dimensional and electrical diagrams for measuring volume resistivity of conductive materials.

MIL-F-87260(USAF)

4.6.23.3 Correlation test data requirements. A correlation study shall be conducted for the conductive material(s) to show the effect of temperature and humidity on the volume resistance and resistivity using the procedure and equipment in 4.6.23.1 and 4.6.23.2. As a minimum, the test data should include tests at $75 \pm 5^\circ\text{F}$ and relative humidities of 10, 50, and 80 ± 5 percent, and material thickness of 1, 4, 8, and 12 inches. In addition, electrical resistivity tests shall be run on one inch thick specimens at $160 \pm 5^\circ\text{F}$, $60 \pm 5^\circ\text{F}$, $30 \pm 5^\circ\text{F}$, $0 \pm 5^\circ\text{F}$, $-20 \pm 5^\circ\text{F}$, and $-30 \pm 5^\circ\text{F}$, and all data reported including relative humidity conditions (if possible). Record all values for resistance, resistivity, temperature, humidity, and material sample overall dimensions (if other than that per 4.6.4). If the conductive material is found to vary more than two orders of magnitude as a result of the humidity changes, then a correlation curve or extrapolation factor should be developed for use on all production bun tests where the test conditions will likely be other than $75 \pm 5^\circ\text{F}$ and 50 ± 5 percent humidity. The correction will enable the qualifying activity to know the resistivity value at standard laboratory conditions (75°F and 50 percent relative humidity). A plot of resistivity versus temperature shall also be generated to demonstrate the material's resistivity properties throughout the anticipated end use temperature range.

4.6.24 Electrostatic fuel impingement test. A fuel impingement test shall be conducted on the conductive material to demonstrate its electrostatic compatibility. The testing shall be done in a small scale rig (55-gallon drum or equivalent). The basic test requirements to be met include:

a. The test tank shall be filled with the conductive material except for a one to two-inch gap (ullage) at the nozzle inlet area.

b. Fuel requirements: MIL-T-5624 grade JP-4 having the following electrical conductivities shall be used for the evaluations: 0 to 10, 50, 100, 200, 500, and 800 cu. The base fuel should be from the same batch and the conductivity level varied through the use of static dissipation additives. The approved additives include ASA-3 (Royal Lubricants Co, Roseland NJ or equivalent) or STADIS 450 (E.I. duPont de Nemours Co, Wilmington DE or equivalent). Information relating to mixing of the additives into fuel can be found in T.O. 42B-1-1.

c. Test temperatures: Fuel test temperatures shall include, but not limited to, $150 \pm 5^\circ\text{F}$, $60 \pm 5^\circ\text{F}$, $30 \pm 5^\circ\text{F}$, $0 \pm 5^\circ\text{F}$, $-20 \pm 5^\circ\text{F}$, and $-30 \pm 5^\circ\text{F}$. The test fuel temperature is defined as the starting test temperature but is not necessarily the fuel temperature at the test end point.

d. The test tank shall be fitted with a straight one-inch diameter inlet nozzle. The flow rates simulated shall be up to 150 gallons per minute (gpm) with an approximate velocity as high as 61 feet per second (fps). The flow rate/velocity shall then be systematically adjusted until the associated discharge activity appears and/or ceases. The critical flow rate/velocity required for discharge activity shall be identified and compared to the candidate material's critical flow rate/velocity for a given standardized fuel. The absence of discharge activity, at the 150 gpm flow rate, may require the straight inlet nozzle's diameter be reduced to allow higher fuel velocities. Any changes in the fuel's electrical conductivity shall be noted and recorded. In addition to discharge activity, charge transfer levels, associated field strength, and induced voltages on an isolated conductor shall be measured.

e. Baseline fuel impingement tests shall also be conducted on the MIL-B-83054 orange (Type I) and the blue (Type IV or V) using the same batch of fuel that is used on the candidate material. This test data will be used for comparison to the data for the candidate conductive material.

f. Appropriate MIL-T-5624 fuel property tests (including existent gum, particulate matter, and filtration time) shall be performed periodically to aid in identifying test facility contamination. Existent gum test should also be run periodically to control the charge tendency of the fuel which may be affected by the extractables from the candidate materials.

g. A suggested test setup for the 55-gallon test rig is shown in Appendix A of this specification.

4.6.24.1 Test data requirements. The critical flow rates associated with the presence of discharges from flow charge generation shall be reported for the candidate material and the blue and orange baseline materials. The associated field

MIL-F-87260(USAF)

strengths, induced voltages, charge transfer levels, and variances in fuel conductivity shall also be reported. In addition, any vapor ignitions that occur shall be documented and the burned material retained for examination.

4.6.25 Infrared spectrum analysis test. The conductive material shall be characterized (identified) by an infrared spectrometer using a frustrated multiple internal reflectance (FMIR) technique. The spectrum shall be of such detail as to clearly distinguish it from the baseline polyether material. A reference polyether spectrum shall be included for comparison. The following criteria shall be satisfied where applicable:

- a. The baseline of the spectrum determined at 5 microns wavelength shall be a minimum of 95 percent transmittance.
- b. The scan speed shall be such as to obtain optimum resolution.
- c. A 45° KRS-5 prism, Perkin-Elmer Corporation P/N 186-1595, or equivalent, and an FMIR attachment, Perkin-Elmer Corporation P/N 186-0174, or equivalent, shall be used to maintain the specimen for analysis. All equipment used as well as details of the test procedure and instrument settings (scan speed, slot setting, etc.) shall be identified for future reference.

4.6.26 Electrochemical corrosion test. This test is intended to identify foam materials that may act as an electrolyte in high humidity environments and in the presence of dissimilar metals. The electrochemical corrosion potential of the conductive material shall be evaluated by placing it in contact with dissimilar metals at $120 \pm 5^\circ\text{F}$ and 100 percent relative humidity for 7 days. Measurements of current flow and corrosion/adhesion shall be made at specified, periodic intervals. For comparison, a similar set of cells, using the vendor's baseline blue polyether (MIL-B-83054) shall also be tested.

4.6.26.1 Testing shall be conducted in a condensing humidity cabinet (bath) at $120 \pm 5^\circ\text{F}$ for 7 days with measurements of initial current flow (after approximately one hour of exposure) and then at 1, 3, 5, and 7 days. Visual inspection and photographing of the plates for corrosion and adhesion shall be performed initially and then at seven days. Test equipment required for the current flow measurements shall include a Keithley Electrometer Model 616, or equivalent. The meter used shall be set to the 10^{-6} ampere scale. Bonding of the test panels shall be with the standard number 18 or 20 AWG wire attached to each plate with "alligator" clamps or with copper-nickel print (adhesive) and epoxy overcoat. The test cells shall consist of a "sandwich" of two standard stock finished metal panels (6 inches x 3 inches x stock thickness), and the conductive material (6 inches x 3 inches x 1 inch). The comparison cells shall have blue polyether foam of similar porosity substituted in place of the conductive material. The metals shall conform to the following specifications:

- a. 305 stainless steel per QQ-P-35.
- b. Bare 7075 aluminum per QQ-A-250/12.
- c. Bare 2024 aluminum per QQ-A-250/4.

The test cell set-up and bonding schematic is shown in Figure 5.

4.6.26.2 Test metal panels shall be precleaned and photographed prior to the test initiation. The precleaning shall consist of the following steps:

- a. Degrease the plates in a trichloroethane vapor pit.
- b. Soak the plates in MIL-C-87936 Type I alkaline detergent (10:1 solution) for 15-20 minutes until water "breaks-free".
- c. Wash (deoxidize) in alcoholic/phosphoric deoxidizer for two minutes at room temperature per ASTM F1110.
- d. Wash in running tap water.

MIL-F-87260(USAF)

- e. Rinse with distilled water.
- f. Force dry with air or nitrogen.

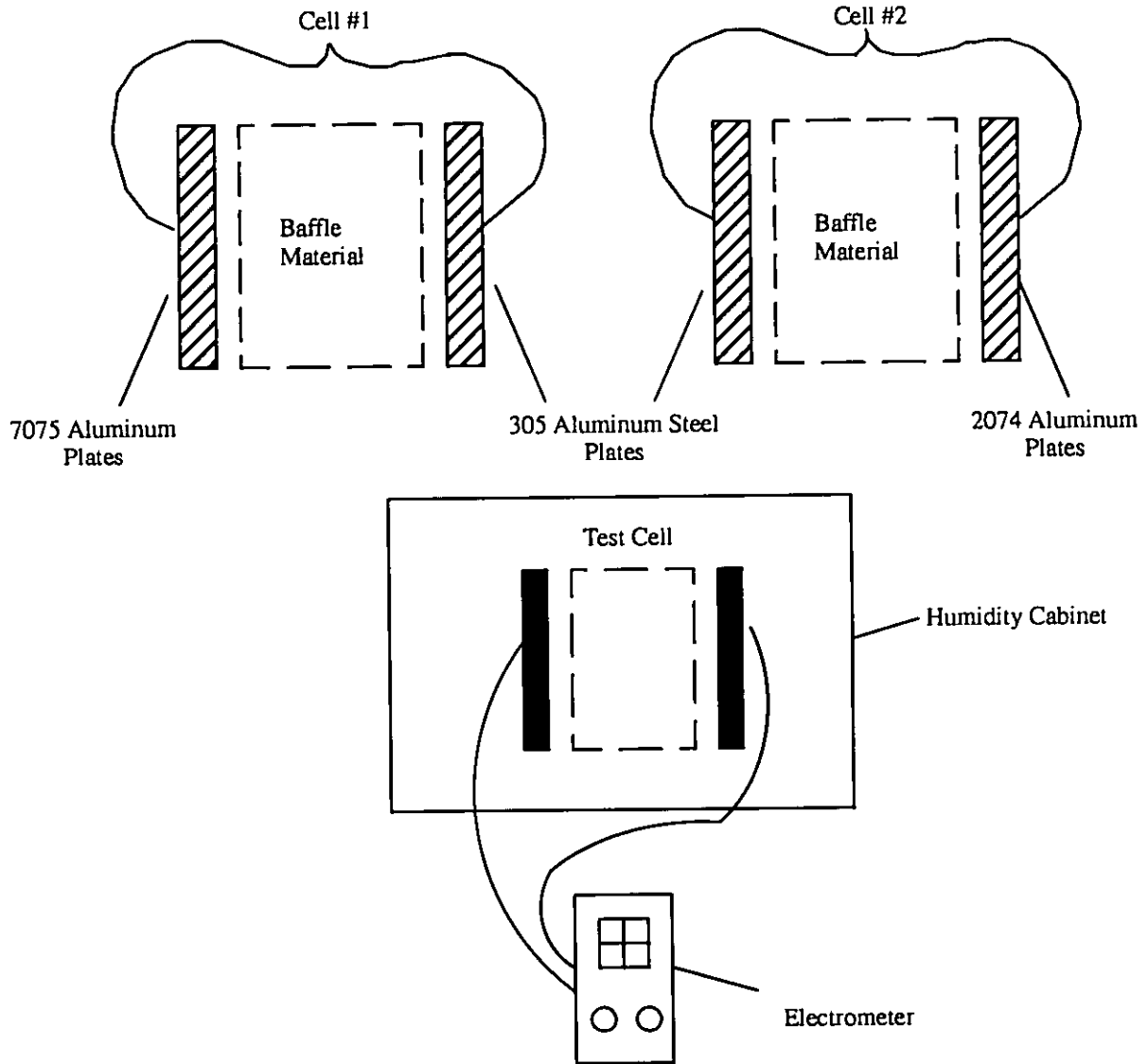
**FIGURE 5. Electromechanical test set-up.**

4.6.26.3 The test exposure shall be accomplished with the plates initially dry. The cells shall be exposed in the vertical position to allow for the drainage of condensing water. The cells may be held together with nylon string or rubber bands to maintain constant contact between metal and foam. The current flow measurements should be made while the specimens are at equilibrium in the humidity cabinet. This requires that the bonding wires be run external to the cabinet for hook-up to the electrometer.

4.6.26.4 At the seven intervals the plates shall be inspected and photographed for any adhesion, corrosion, erosion, pitting, discoloration or staining. The following procedure shall be used to evaluate the plates:

MIL-F-87260(USAF)

a. The surfaces of the plates which were in contact with the foam material shall be inspected for discoloration, deposits, and pitting. If any of these conditions exist, the surface of the plates shall be washed in precipitation naphtha. Deposits determined as urethane materials or elements of the baffle material, which can be removed by this process, shall be construed as adhesion.

b. If any other marks remain on the surface of the plates after being washed in precipitation naphtha, the surface shall be lightly polished with a nonabrasive cloth buff. Any pits or eroded marks remaining after this process shall be construed as corrosion. Discoloration or staining (marks which do not physically affect the surface of the plates and which easily wash or buff off) shall not be considered detrimental.

4.6.26.5 Qualification report. All test results and photographs shall be included in the qualification report. In addition, the test specimens shall be forwarded to the qualifying activity for review and inspection.

4.6.27 Marker legibility test. A marker legibility test shall be conducted to identify a suitable marker which can be used for individual foam kit component identification before installation into the aircraft fuel system. The marker shall be fuel compatible and shall be of a legible color (either white or black) with respect to the candidate material color. The test may be conducted in conjunction with the JP-4 fuel immersion test. A resistivity specimen, per 4.6.4, shall be marked with the selected marking pen, and then exposed to the 160°F JP-4 immersion environment for four weeks. The identification marking used shall be "590-51B" and shall be 1/2 inch to 2 inches in height. Color photographs shall be taken of the specimens both before and after exposure. The exposed specimens and the photographs shall be submitted to the qualifying activity for evaluation. NOTE: Do not include this specimen in the resistivity measurements for the JP-4 immersion test.

4.6.27.1 Suggested markers. Suggested markers to be considered for this test are as follows:

- a. Blaisdell 1173F (black marker), Blaisdell Co., Bethayres, PA, or equivalent.
- b. Diagraph GP-X (white marker), Diagraph Bradley Industries Inc., Herrin, IL, or equivalent.
- c. Commercial marking pen ink per A-A-208.

4.6.27.2 Test report. The test data and photographs shall be included in the qualification report. In addition, all specimens tested shall be submitted to the qualifying activity.

4.6.28 Electrostatic charge dissipation test. The material shall be evaluated for its ability to dissipate static charges as a function of temperature. The test shall be conducted in accordance with the procedure in Federal Test Method Standard (FTMS) 101, Method 4046.1 dated 8 Oct 1982 titled "Electrostatic Properties of Materials", except that the static decay cutoff shall be 10% (500 volts). In addition, the static decay times of the material(s) shall be determined at 60, 32, 0, -20, -30, and -40 ±5°F.

4.6.28.1 Test equipment. A suggested static decay set-up employs an Electro-Tech Systems model 4066 static decay meter, a model 506 humidity control chamber, and a model 512 automatic humidity controller (or its equivalent). A suggested supplier is Electro-Tech Systems Inc., 115 E. Glenside Avenue, Glenside, PA 19038. The test equipment must be housed in a variable cold temperature box capable of controlling temperature from 60°F down to -40°F.

4.6.28.2 Specimen preparation, conditioning and mounting

a. Test specimen shall be 3.0 inches (7.62cm) x 5.0 inches (12.7cm) x 1/2 inch +1/8 inch (0.32cm) -0 inch. The five-inch dimension shall be cut along the axis of the machine travel. The 1/2 inch dimension shall be cut along the direction of foam rise.

b. Prior to testing, specimens shall be conditioned at least one hour in an atmosphere uniformly maintained at 73 ±5°F and a relative humidity of 12 ±5 percent.

MIL-F-87260(USAF)

c. Each specimen, when tested, shall be mounted vertically between the electrodes and the wing nuts shall be tightened in such a manner to insure intimate contact with the electrode surfaces without causing visible distortion or compression of the specimen.

d. For qualification, the static decay and static decay uniformity shall be established by evaluating a standard bun of the finished material at several locations (four minimum) from various positions in the bun (top, middle, and bottom of the bun height).

4.6.28.3 Test procedure and calibration Prior to testing the specimens of conductive foam, the static decay meter shall be calibrated as follows:

a. Mount the Electro-Tech CM-1 calibration module in the Faraday cage in place of a normal test sample. Insert the calibration module's banana plug into the calibration jack at the bottom of the Faraday cage. Close the door of the Faraday cage.

b. Set the cutoff threshold to 500 volts (10%).

c. Turn the power on.

d. *With the unit in zero/standby, set the sample charge meter to zero by adjusting the zero calibration control.*

e. Select the desired polarity of the charging voltage plus or minus.

f. Rotate the high voltage adjust control to set the charging voltage to 5,000 volts.

g. Charge the calibration module. Adjust the sample charge meter to 5,000 volts.

h. Start the test. The decay time shall be within 0.05 seconds of the marking on the CM-1 calibration module in both the positive and negative modes.

4.6.28.4 Specimen test procedure. The following procedure shall be used to determine the voltage decay times at each of the specified temperature conditions:

a. Remove the calibration module from the Faraday cage and mount a specimen of conductive foam. Close the Faraday cage.

b. Set the threshold cutoff to 10% (500 volts) and select the desired polarity of the charging voltage.

c. With the unit in zero stand by, set the sample charge to zero.

d. *With the high voltage off, depress the charge button and check the reading of the sample charge meter. If there is any movement of the sample charge needle, the test sample has an initial charge.*

e. Return the unit to zero stand by. Turn on the high voltage and adjust to 5,000 volts.

f. Charge the specimen and adjust to 5,000 volts.

g. Time until the charge dissipates to 500 volts. Record the static decay time.

4.6.28.5 Correlation of test data. Once the decay times are established over the temperature range, the results shall be combined with the corresponding electrical resistivities of the material to determine the material's power dissipation rate (watts/sec). The formula for calculating the power dissipation rate and sample calculations/data are presented in Appendix C. A sample graphical representation of data for several foam materials are also provided in figure 1 of Appendix C.

MIL-F-87260(USAF)

4.6.28.6 Report. Report sample designation (run or lot number), conditioning time, charge cutoff, and three static decay results for each polarity (plus or minus) for each specimen, at each designated temperature. All calculation for power dissipation (watts/second) shall be provided. A graphical representation of power dissipation rates vs. temperature shall be made and the material DTL determined from the resulting curve. If the DTL cannot be determined by this graphical method, then it can be determined as the temperature at which the curve intersects the 0.15×10^{-6} watts/second point.

4.6.29 Aircraft service test evaluation. A full scale aircraft service test evaluation of the electrically conductive material shall be conducted for a minimum of six months prior to approval of a material for the Qualified Products Listing (QPL). The test shall be conducted under controlled conditions and samples of the product shall be removed from the aircraft fuel system for evaluation of critical properties. These critical properties shall include, but shall not be limited to, electrical resistivity, tensile strength, contamination, and compression load deflection. The installation shall include, as a minimum, one complete fuel tank on a given aircraft, and should preferably include the entire fuel tankage. Test samples (various foam kit pieces) of the product shall be identified in several fuel tank locations and tested for initial electrical resistivity (through the piece thickness) prior to fuel tank installation. The selected foam kit pieces will be removed at 3 to 6-month intervals depending on the service test duration. Additional foam kit pieces shall also be provided to replace those pieces that are removed for critical property testing. The material vendor shall conduct laboratory evaluations of the test specimens if requested. A detailed service test plan shall also be provided to the qualifying activity for approval prior to initiation of the service evaluation. If possible the testing should be conducted in a severe (cold) climate where electrostatic generation, discharges, ignitions were prevalent with blue polyether foam. Consideration should also be given to demonstrating over-the-wing (gravity) refueling if available on the aircraft. Guidelines for designing a foam kit for use in fuel tanks are provided in SAE AIR-4170.

4.7 Inspection of preparation for delivery. Inspection of the preservation, packaging, packing, and marking for shipment shall be in accordance with the requirements of Section 5.

5. PACKAGING

5.1 Preservation and packaging. The material (buns) shall be preserved and packaged in accordance with MIL-P-116, method III.

5.1.1 Buns. The finished material (buns) shall be enclosed and sealed in a 4 mil black polyethylene (plastic) wrap conforming to L-P-378, type I, class I, grade B. If tape sealing is used, it shall be 3M clear tape, P/N 19280 (Highland Brand Utility 371), or equivalent. See 3.9 for further details.

5.2 Packing. Packing shall be level A, B, or C as specified (see 6.2).

5.2.1 Level A. Buns preserved and packaged as specified in 5.1, shall be packed in quantities of one, two, or three (or equivalent volume) in a weather-resistant exterior container selected from and in accordance with MIL-STD-2073-1 and MIL-STD-2073-2.

5.2.2 Level B. Buns preserved and packaged as specified in 5.1, shall be packed as specified in 5.2.1, except containers shall be of the domestic type. If containers conforming to PPP-B-636 are used, the total size limitation specified may be waived.

5.2.3 Level C. Buns preserved and packaged as specified in 5.1, shall be packed as specified in quantities of one, two, or three each (or equivalent volume) in a manner to insure acceptance by common carrier and afford protection against physical and mechanical damage during shipment from the supply source to the first receiving activity for immediate use. Minimum overwrap for each unit package quantity shall be 8 mil black polyethylene conforming to Federal Specification L-P-378, Type I, Class I, Grade B. This level shall comply with uniform freight classification rules and regulations or other carrier regulations as applicable to the mode of transportation.

MIL-F-87260(USAF)

5.3 Marking. Marking shall be in accordance with MIL-STD-129. The nomenclature shall be as follows:

INHERENTLY ELECTRICALLY CONDUCTIVE EXPLOSION SUPPRESSION
MATERIAL, AIRCRAFT FUEL TANK AND DRY BAY AREAS

5.3.1 Additional marking. In addition to the nomenclature, each unit package or container shall contain the following information:

Specification number

Class and Grade of material

Manufacturer's part number

Date of manufacture

6. NOTES

(This section contains information of a general or explanatory nature that may be helpful, but is not mandatory.)

6.1 Intended use. The materials covered by this specification are intended for use in aircraft and ground vehicles fuel tanks using gasoline or kerosene type fuels at temperatures from $-55 \pm 5^{\circ}\text{F}$ to $160 \pm 5^{\circ}\text{F}$ for explosion and fire suppression. The materials may also be used in dry bay areas (cavities) where the temperatures do not exceed 160°F . Temperatures greater than 160°F and high humidity conditions will shorten the service life. These materials are intended to replace all the currently used foams qualified under MIL-B-83054. The advantages of these conductive materials include potentially longer service life and reduced incidents of electrostatic charge generation, discharge, and vapor ignitions that were experienced with the previous polyester/polyether materials.

6.2 Acquisition requirements. Acquisition documents should specify the following:

- a. Title, number, and date of this specification.
- b. Issue of DODISS to be cited in the solicitation, and if required, the specific issue of individual documents referenced (see 2.1).
- c. Class and Grade of material required (see 1.2) and size (see 3.8).
- d. Location and conditions for testing and government inspection and acceptance (see 4.4).
- e. Location of markings (3.8)
- f. Level of packing required (see 5.2).

6.3 Consideration of data requirements. The following data requirements should be considered when this specification is applied on a contract. The applicable Data Item Descriptions (DID's) should be reviewed in conjunction with the specific acquisition to ensure that only essential data are requested/provided and that the DID's are tailored to reflect the requirements of the specific acquisition. To ensure correct contractual application of the data requirements, a Contract Data Requirements List (DD Form 1423) must be prepared to obtain the data, except where DOD FAR Supplement 27.475-1 exempts the requirement for a DD Form 1423.

MIL-F-87260(USAF)

<u>Reference Paragraph</u>	<u>DID Number</u>	<u>DID Title</u>	<u>Suggested Tailoring</u>
4.4.2	DI-MISC-80653	Test Reports	
4.6.20.2	DI-MISC-80653	Test Reports	
4.6.27.2	DI-MISC-80653	Test Reports	

The above DID's were those cleared as of the date of this specification. The current issue of DOD 5010.12-L, Acquisition Management Systems and Data Requirements Control List (AMSDL), must be researched to ensure that only current, cleared DID's are cited on the DD Form 1423.

6.4 Qualification. With respect to products requiring qualification, awards will be made only for products which are, at the time of award of contract, qualified for inclusion in the applicable Qualified Products List whether or not such products have actually been so listed by that date. The attention of the contractors is called to these requirements, and manufacturers are urged to arrange to have the products that they propose to offer to the Federal Government tested for qualification in order that they may be eligible to be awarded contracts or purchase orders for the products covered by this specification. The activity responsible for the Qualified Product List is the Department of the Air Force, WL/MLSE, Wright-Patterson Air Force Base, Ohio, 45433-6503, and information pertaining to qualification of products may be obtained from that activity.

6.4.1 Qualifying activity. The organization responsible for qualification approval for material covered by this specification:

Wright Laboratories
ATTN: WL/MLSE
Wright-Patterson AFB, OH 45433-6503

6.4.2 Qualification tests. The qualification tests contained in this specification are considered adequate to insure that the explosion suppression material procured under this specification is satisfactory for the intended purpose provided the materials are similar to polyurethane reticulated foam. The qualifying activity may specify additional testing or materials submitted for qualification approval with chemical and mechanical properties not anticipated in the preparation of this specification. These tests may include, but shall not necessarily be limited to, the following: ballistic response (gunfire), fuel flow and pumpdown, venting, icing, and fuel system compatibility.

6.5 Supersession data. The inherently electrically conductive explosion suppression materials conforming to this specification supersedes all previous non-conductive explosion suppression foam baffle materials governed by MIL-B-83054, for new procurement applications.

6.6 Definitions. For the purpose of this specification, the following definitions shall apply:

6.6.1 Run of material. Any continuous batch of product or a machine run produced over any continuous time period, the maximum run time being a 12-hour period. When production is interrupted for two or more hours, this will constitute a new run.

6.6.2 Test section width. The standard width direction on a bun (40 or 44 inches).

6.6.3 Direction of rise. The height direction relative to the standard bun (the 4, 8, or 12-inch direction).

6.6.4 Machine direction. The lengthwise direction during production or the longest dimension relative to the standard bun size.

6.6.5 Lot. Fifteen machine runs of product.

6.7 Classes. The class distinction noted in the specification is intended to separate the available products by their ability to dissipate static electricity at low fuel temperatures. Testing has indicated that below the low temperature fuel limits

MIL-F-87260(USAF)

stated (class 1 is 0°F and class 2 is -30°F) the material will generate excessive static electricity when impinged by high velocity fuel and as such may result in discharge and vapor ignition. This in itself is not a safety problem for single point refueling since the foam suppresses the resulting explosion internally; however, in the case where over the wing (gravity) type refueling is used, then a potential hazardous situation exists to refueling personnel and equipment since the fuel vapor can be ignited as it exits the filler opening. Requirements for interchangeability of products are as follows:

a. Class 2 products are interchangeable (substitutable) for class 1 materials; however, only if it is the same grade (example: grade IC for grade IC and grade IIC for grade IIC).

b. Class 1 products are not interchangeable for Class 2 materials unless it is determined that the low temperature requirements can be waived or gravity refueling is restricted to emergency operations.

6.8 Installation guidelines for reticulated foam in aircraft fuel tanks and dry bays. Guidelines for the proper design and installation of various reticulated foams can be found in SAE AIR 4170.

6.9 Air deionizer. An available source for the model 2U500 air deionizer specified in 4.6.15 is the Nuclear Products Company, 2519 N. Merced Avenue, South El Monte, CA 91733.

6.10 Subject term (key word) listing.

- Baffle
- Ballistic foam
- Combat protection
- Dry bay explosion protection
- Fire and explosion
- Fuel tank explosion protection
- Inerting
- Passive system
- Reticulated polyurethane foam
- Safety foam (SAFOAM)
- Slosh attenuation
- Survivability enhancement

Custodian:
AF-11

Preparing Activity:
AF - 11

Project Number: 9330-F004

**MIL-F-87260(USAF)
APPENDIX A**

GUIDELINES FOR SMALL SCALE FUEL IMPINGEMENT EVALUATION

10. SCOPE

10.1 Scope. This appendix contains guidelines for the small scale fuel impingement evaluation of reticulated foam products. The equipment, procedures, and data requirements specified in this appendix may be used for evaluating the electrostatic charge generation and ignition characteristics of reticulated foams (explosion suppression material) by impinging fuel at high velocities onto the material. Measurements of voltage buildup on an isolated conductor within the tank are used as a criteria for evaluation of a product. Electrical activity/discharges/vapor ignitions are other criteria also used to evaluate the acceptability of the product. This appendix is not a mandatory part of the specification. The information contained herein is intended for guidance only.

20. APPLICABLE DOCUMENTS.

American Society for Testing and Materials

D1655-89 Standard Specification for Aviation Turbine Fuels

30. TEST EQUIPMENT AND MATERIALS. The following minimum equipment is suggested for proper conduct of the testing:

- a. Three standard 55-gallon unlined steel drums, modified per the schematics.
- b. Fuel inlet: Standard pipe nozzle (0.82 inch inside diameter).
- c. Fuel lines and fittings to provide transfer of fuel at a maximum flow rate of 65 gpm (60 ± 5 gpm) to the test tank (drum).
- d. Fuel transfer pump and valving to adjust flow rate to the specified rate of 60 ± 5 gpm (37 ± 5 fps at inlet).
- e. Thermometer and portable fuel conductivity meter for checking temperature and electrical conductivity of the test fuel before and after each test.
- f. *Equipment for measuring the ambient temperature and relative humidity around the test area.*
- g. Steel probe and teflon isolator for use in measuring voltage buildup within the tank.
- h. Electrostatic voltmeter and recorder (printer) and/or mag tape recorder for measuring and recording voltage buildup vs time in the tank.
- i. Equipment for measuring the electrical resistivity of the test foam material prior to and after a test series on a product.
- j. Fuel conforming to MIL-T-5624 or ASTM D1655, grade JP-4 or Jet B respectively as the preferred fuel; however, JP-5, Jet A, Jet A1 or JP-8 (MIL-T-83133) are approved alternates. The primary test fuel should be "free" of conductivity additive (antistatic additive) and have a conductivity of less than 10 cu. In addition, testing with ASA

MIL-F-87260(USAF)**APPENDIX A**

additives at 50, 100, 200, 500, and 800 conductivity units should be accomplished by mixing the fuel/additive to the desired level.

k. Test foam: Baseline orange polyester and blue polyether ESM per MIL-B-83054, Types IV and V, as well as the conductive candidate material in the proper porosity range(s). All drums shall be filled with foam for safety purposes.

l. Photographic equipment for documenting the test setup and fuel vapor ignitions (flame out vent) including burned/singed foam.

40. TEST PARAMETERS AND DETAILS. The basic test setup is shown on Figure 1 utilizing three standard (uncoated) 55-gallon drums as the basic tank and fuel collector reservoir. The fuel should be transferred with an electrically driven fuel transfer pump from the reservoir outlet to the test tank inlet located at the top of the upper tank. The suggested flow rate is 60 ± 5 gpm with corresponding inlet velocity of 37 ± 5 fps at the pipe inlet nozzle (3/4 inch outside diameter). An ullage (gap) of one to two inches should be provided at the fuel inlet between the nozzle and foam in the tank. All tanks should be filled with foam (cylinders) cut to the drum inside diameter and 6, 8, or 12 inches high (or combinations thereof). The test drum foam should be dry at the beginning of each sequence of tests in order to provide a worse case condition. The fuel should be fresh and should not contain any trace of electrical conductivity type additives and be verified by test just prior to and after each evaluation. The preferred fuel type is JP-4 or Jet B; however, tests can be run using JP-5, JP-8, Jet A, or Jet A1 as long as the properties of the fuel are documented and within specification limits (MIL-T-5624, MIL-T-83133 or ASTM D1655 as applicable). A minimum of three test runs lasting five to twenty minutes shall be run on each foam type and configuration. The three runs can be run consecutively starting with dry foam at the beginning of each sequence (three tests). A 5-minute (minimum) down time shall be maintained between test runs for charge relaxation, appropriate data measurements, and test tank should be done at a low temperature and relative humidity to enhance static electricity generation. Specifically, temperatures below 50°F and 50 percent relative humidity are desirable; however, if these conditions cannot be attained, then it will not be a limiting factor for conduct of the testing. In order to evaluate the potential effects of temperature on the static electricity generation, it is recommended that several fuel temperatures be evaluated and an optimum set of conditions chosen for the final evaluation of the conductive foam. These include the following temperatures: 140°F, 60°F, 30°F, 0°F; -20°F, and -40°F. The test fuel temperature is defined as the temperature at which the bulk fuel shall be at the start of a test run. If an ignition occurs during a test, the drum shall be opened and the damaged foam replaced and photographed.

50. Test foam types and configurations. Baseline foam tests should be run on orange and blue MIL-B-83054, Types II, IV or V polyester and foams to demonstrate the electrical charge generation/ignition characteristics of the material and measurement capability of the test rig instrumentation. Two test configurations shall be run: (a) fully packed, and (b) "over the wing" refueling inlet simulation. The test tank configurations are shown on Figures 2 and 3 for reference. The "over the wing" void should be four inches in diameter and centered under the nozzle inlet. A one to two-inch ullage shall also be provided just above the foam cylinders in the test tank. Fuel impingement tests should be run on each porosity type of foam being qualified, that is, coarse and fine pore or Types I and II respectively. Also, both configurations, fully packed and "over the wing" voiding, shall be evaluated on each type of foam being qualified unless it can be shown that the fully packed condition is a worse case.

60. Test data and documentation. Prior to any conduct of testing, a test procedure shall be written and submitted for approval. Photographs of the test setup and instrumentation shall be included if available. Typical test data requirements are outlined in the attached data sheets (Figures 4 and 5). Copies of data traces shall also be provided with adequate labeling and identification.

MIL-F-87260(USAF)
APPENDIX A

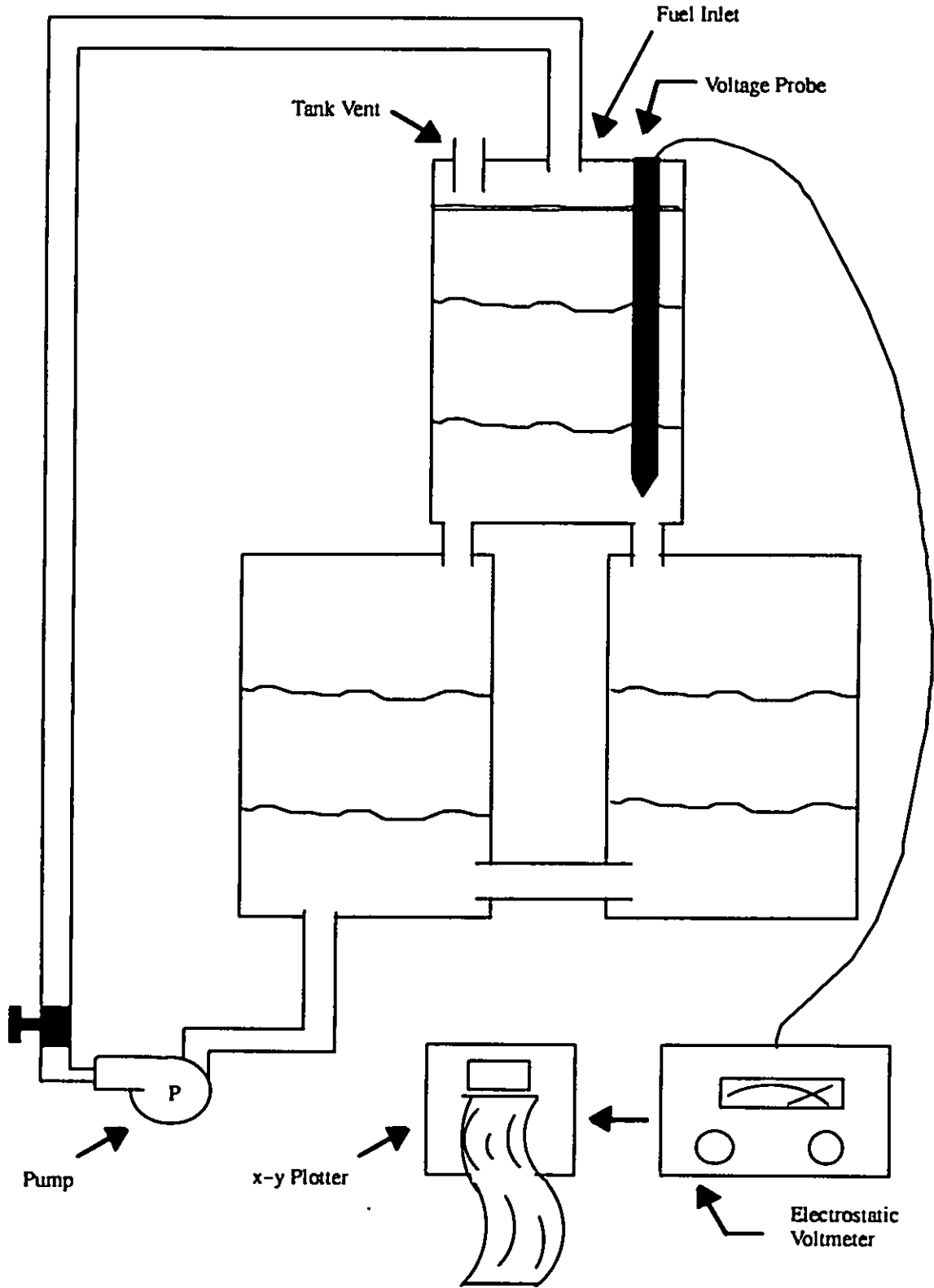

FIGURE 1. Fuel impingement test set-up schematic.

MIL-F-87260(USAF)
APPENDIX A

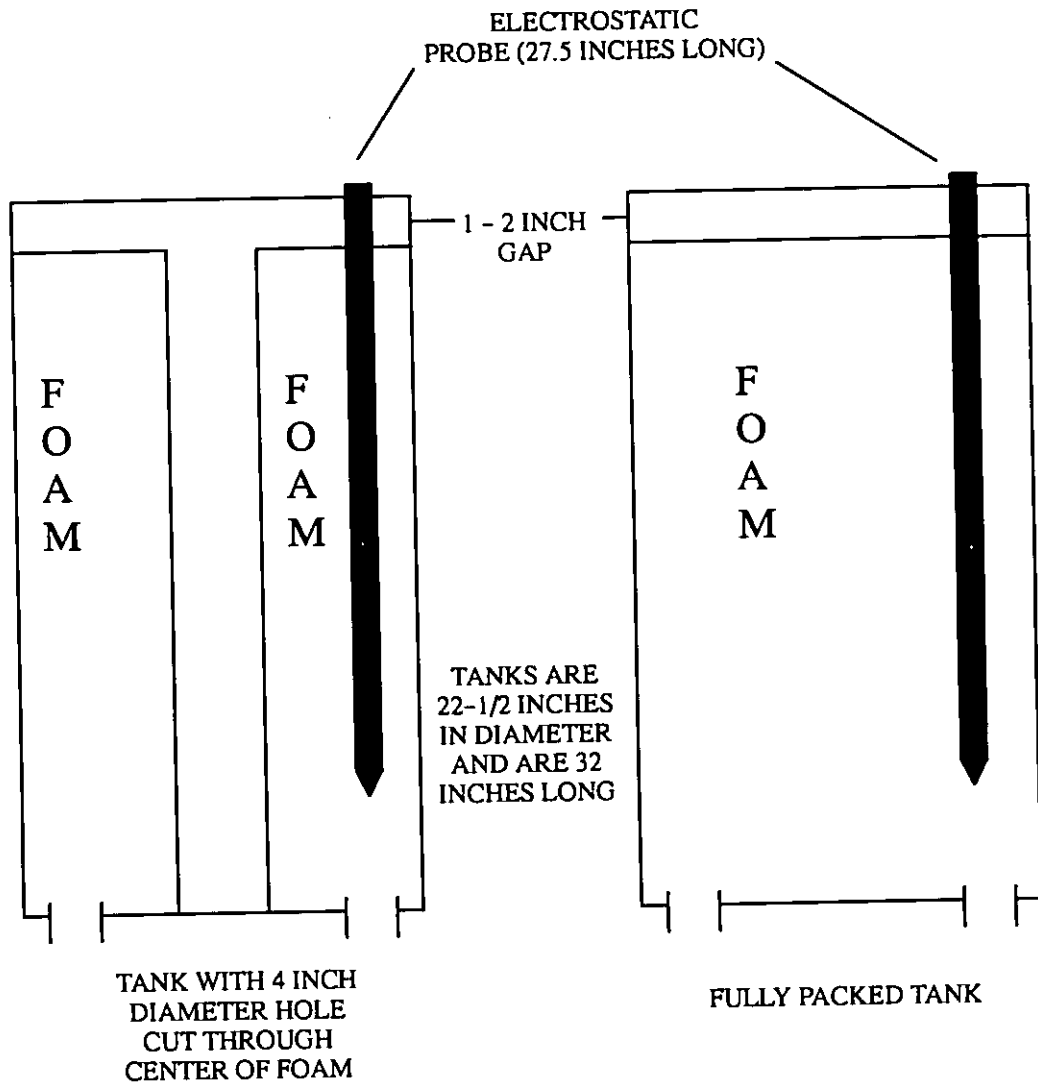

FIGURE 2. Schematic of two different impingement scenarios.

**MIL-F-87260(USAF)
APPENDIX A**

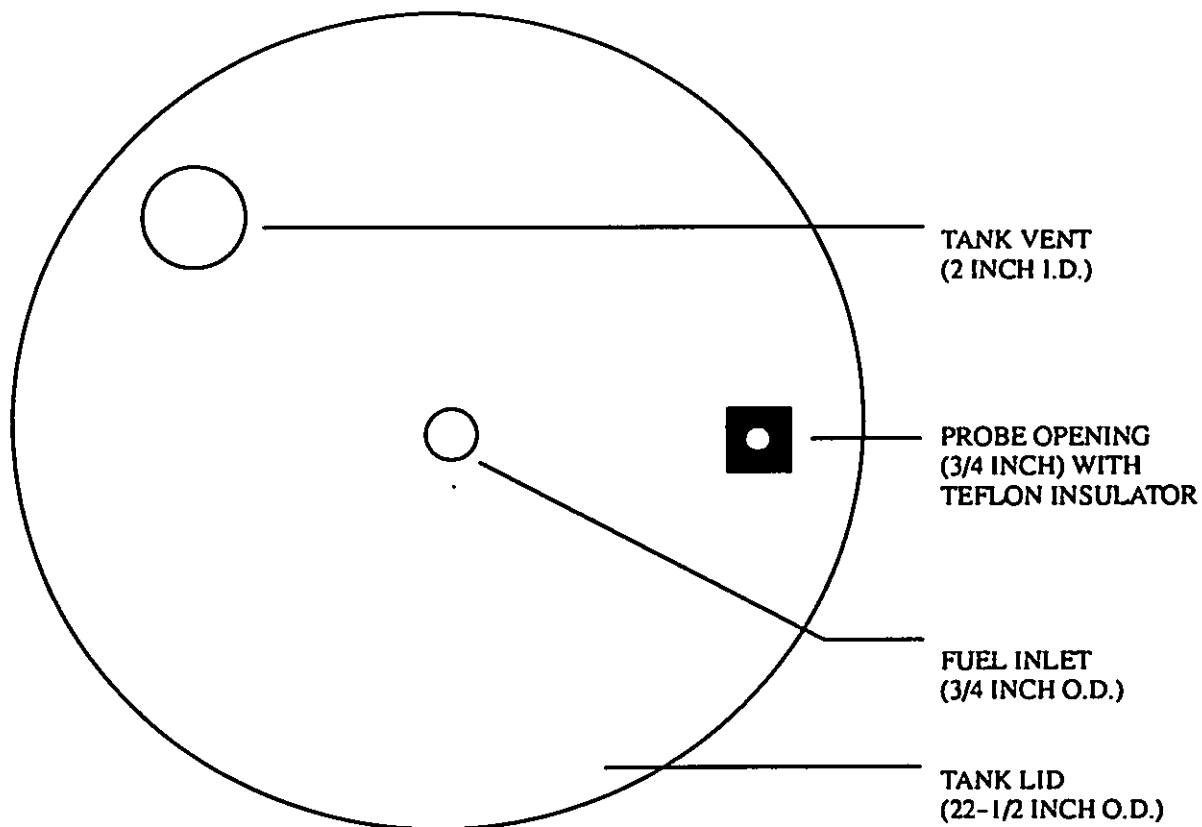

FIGURE 3. Tank lid for the uppermost tank of the fuel impingement test rig.

**MIL-F-87260(USAF)
APPENDIX A**

FUEL IMPINGEMENT SUMMARY TEST DATA SHEET

Test # _____ Date _____ Time _____

Foam Type: Dry or Wet

Fuel Type: Conductivity

Fuel Test Temp: Start _____ End _____

Ambient Conditions: Temperature _____ (% RH _____)

Type Conductivity Additive used _____ (PPM _____)

Test Run Data Summary: Test Run Time _____

Maximum Voltage _____ (Time: _____)

Sparks? Electrical Activity

Vapor Ignition (explain)

Visual Inspection/Observations:

Foam Kit Data	Part Number	Thickness	Resistivity
Top Piece			
Center Lower			
Center Upper			
Bottom			

Figure 4. Fuel impingement summary test data sheet.

FUEL IMPINGEMENT TEST DATA SHEET

TEST # _____

DATE: _____

FOAM TYPE: _____
DRY: _____ WET: _____

TIME

VOLTAGE

FLOW

FUEL TEMP

NOTES

FOAM LAYOUT

ULLAGE VOID:

PN _____

PN _____

PN _____

PN _____

TEST CONDITIONS:

QAT %RH TIME

_____ START

_____ END

FUEL CONDUCTIVITY DATA:

TEMP CU

START _____

END _____

ADDITIVE TYPE _____

ULLAGE VOID

TEST ENGINEER

FIGURE 5. Fuel impingement test data sheet.

**MIL-F-87260(USAF)
APPENDIX B**

**FLAMMABILITY TEST FOR
THE RATE OF BURNING AND/OR EXTENT AND TIME OF
BURNING OF CELLULAR PLASTICS USING A SPECIMEN
SUPPORTED BY A HORIZONTAL SCREEN**

10. SCOPE

10.1 Scope. This method covers a small-scale horizontal laboratory screening procedure for measuring the rate of burning and/or extent and time of burning of rigid or flexible cellular plastics in accordance with this test procedure.

10.2 Caution. During the course of combustion, gases or vapors, are evolved which may be hazardous to personnel. Adequate precautions should be taken to protect the operator.

20. APPLICABLE DOCUMENTS. This section is not applicable to this appendix.

30. SIGNIFICANCE

30.1 Tests made on cellular plastic under conditions herein prescribed can be of consideration value in comparing the rate of burning and/or extent and time of burning of different materials, in controlling manufacturing processes, or as a measure of deterioration or change in burning characteristics prior to or during use.

30.2 This method is not intended to be a criterion for fire hazard. The fire hazard created by materials depends upon the form and end use of the material. Assessment of fire hazard includes, but is not limited to, many factors, such as, ease of ignition, burning rate, flame spread, fuel contribution, intensity of burning, and products of combustion.

40. APPARATUS

40.1 Test chamber. Any enclosure is satisfactory that is large enough to provide quiet draft-free air around the specimen during test, yet will permit normal thermal circulation of air past the specimen during burning. A hood is recommended in order to remove the sometimes noxious products of combustion. If a test chamber is used, it should be of such a design that it can be used in a hood. For referee purposes, test results with the chamber should be the same whether or not the hood exhaust is on. In cases of discrepancy, values obtained with the damper closed or the hood fan off, or both, will be considered valid.

40.1.1 The recommended test chamber should be constructed of sheet metal or other fire-resistant material, having inside dimensions 300 mm wide, 600 mm long, and 760 mm high, open at the top, with a ventilating opening approximately 25 mm high around the bottom. A viewing window of heat-resistant glass should be of sufficient size and in such a position that the entire length of the specimen under test may be observed. The chamber should be readily opened and closed to facilitate mounting and ignition of the test specimen.

40.2 Burner. A standard 9.5 ± 0.5 mm outside diameter barrel Bunsen or tirril burner fitted with a 48 ± 1 mm wide wing top. The wing top may have to be opened to approximately 3 ± 0.1 mm to provide the flame required in 6.4.

40.3 Fuel supply. Propane gas of at least 85 percent purity.

40.4 Specimen support. Wire cloth (wire screen) 6.5 mm mesh using 0.8 mm diameter steel wire. Stainless steel wire cloth can be obtained from Cleveland Wire Cloth and Mfg. Co., 3573 E. 78th St., Cleveland, Ohio 44105. The wire cloth specimen support 75 x 215 mm shall have a 15 ± 1 mm of length bent to form a right angle. This will form the specimen support as shown on Figure 1.

40.5 Specimen support holders. Any holding device that will clamp the wire cloth specimen support horizontally so that the bottom of the bent-up portion is 13 ± 1 mm above the top of the burner wing top, as shown on Figure 2. A typical arrangement consists of two laboratory ring stands with two adjustable flat surface clamps which may be locked in place by set screw and lock nut.

**MIL-F-87260(USAF)
APPENDIX B**

40.6 Sheet of asbestos board. A sheet of asbestos board 250 x 250 x 6.5 mm shall be placed on the bottom of the test chamber.

40.7 Aluminum foil

40.8 Timing device. Accurate to ± 1 second.

40.9 Measuring scale. Graduated in at least 2.0 mm intervals.

40.10 A device to ensure correct relative positioning of burner and specimen.

50. TEST SPECIMENS

50.1 Five specimens 50 \pm 0.25 mm wide x 150 \pm 1 mm long shall be tested.

50.1.1 Specimens shall be cut from representative material. Materials supplied in thickness over 13 mm shall be cut to 13 mm thickness. Materials foamed in thicknesses of 13 mm or less shall be tested at the thickness supplied.

50.1.2 Materials with directional effects such as skin or inserts shall be oriented so as to provide the most adverse results.

50.1.3 Sheet samples shall be cut from a thickness of sheet normally supplied or molded to a desired thickness.

50.1.4 Molded expanded or sponge materials not conforming to the width requirements in 3.1 shall be tested as agreed upon between the manufacturer and purchaser.

50.1.5 Each test specimen shall be marked across its width by one line 125 mm from one end.

60. CONDITIONING

60.1 Specimens shall be preconditioned prior to test for a minimum of two hours in the laboratory test environment where the conditions of temperature and humidity are known.

70. PROCEDURE

70.1 Clamp the wire cloth specimen support horizontally so that the bottom of the wire cloth is 13 \pm 1 mm above the top of the burner wing as shown on Figure 2. Cover the sheet of asbestos board with a layer of aluminum foil and place it on the bottom of the test chamber to catch any dripping or flaming particles. The distance between the wire cloth and the foil shall be between 150 and 200 mm. Change the foil after each test, if there is any debris on the surface from the previous determination. Burn off any material remaining on the wire cloth from the previous tests, or use a new wire cloth for each test. If a new wire cloth is not used for each test, the wire cloth should be cool to the touch before being used. If dripping or melting material fall into the wing top, clean it before testing the next specimen.

70.2 Place the specimen on the support with one end touching the 15 mm bent-up portion of the support. The end of the specimen nearest the gage mark should be away from the bent-up end of the specimen support, so that the gage mark is 125 mm away from the bent-up end.

70.3 Adjust the burner with the wing top to provide a blue flame whose visible portion is 38 \pm 2 mm high with a clearly defined inner cone 6.5 \pm 1.0 mm high as shown on Figure 3. Place the burner under the upturned end of the specimen support so that one edge of the flame is in line with the upturned end of the wire cloth and the other edge of the flame extends into the front end of the specimen.

70.4 Start the timing device when the flame is first applied to the specimen. After 60 seconds, move the burner at least 150 mm away from the test specimen. Record the time in seconds when the flame front reaches the gage mark; if this does not occur, record the time in seconds for the flame front to go out. If the flame goes out before reaching the gage mark, the

MIL-F-87260(USAF) APPENDIX B

extent of burning is equal to 125 mm minus the distance from the gage mark to the nearest evidence of the flame front, such as charring, along the upper surface of the specimen measured to the nearest two mm. Note burning characteristics such as intumescence, melting, dripping, or smothering. Also record if the dripping on the foil burns. In some cases, the burning may cease in the first 60 seconds. This is evident by the disappearance of yellow or characteristic flame.

80. CALCULATIONS

80.1 If the flame front passes the gage mark in any one of the five specimens, the sample shall be judged as burning. The burning rate is calculated by the following equation:

$$A = \frac{B}{C}$$

where:

- A = burning rate, mm/s,
- B = distance to gage mark 125 mm, and
- C = time for flame to reach gage mark, sec.

If only one specimen burns past the gage mark, its burning rate shall be reported, otherwise the average of the specimens that burn past the gage mark shall be reported.

80.2 If the flame front does not reach the gage mark for all five specimens, average the burning time in seconds and average the distance burned in millimeters as measured on the top surface.

90. REPORT

90.1 The report (DI-MISC-90653) shall include the following:

90.1.1 A description of the material including the density, the width and thickness, and any prior treatment or conditioning and the presence or absence of skin. If the specimen had skins, the report shall include whether the skin surface was up or down.

90.1.2 Sample that burned to the gage mark, the burning rate in millimeters/second.

90.1.3 For samples that did not burn to the gage mark, report the average time of burning and the average extent of burning.

Example:

$$ATBXX, AEBXX_{mm}$$

where:

- ATB = average time of burning, and
- AEB = average extent of burning.

90.1.4 A description of burning characteristics such as melting, dripping or intumescence and whether the dripping or melting materials continued to burn on the aluminum foil.

10. PRECISION

100.1 Interlaboratory round-robin testing has established the precision for each part of the test as follows:

100.2 Reproducibility. The standard deviation for interlaboratory reproducibility is:

For burning rates	±0.08 mm/sec
For ATB	±8.5 sec
For AEB	±9.9 mm

MIL-F-87260(USAF) APPENDIX B

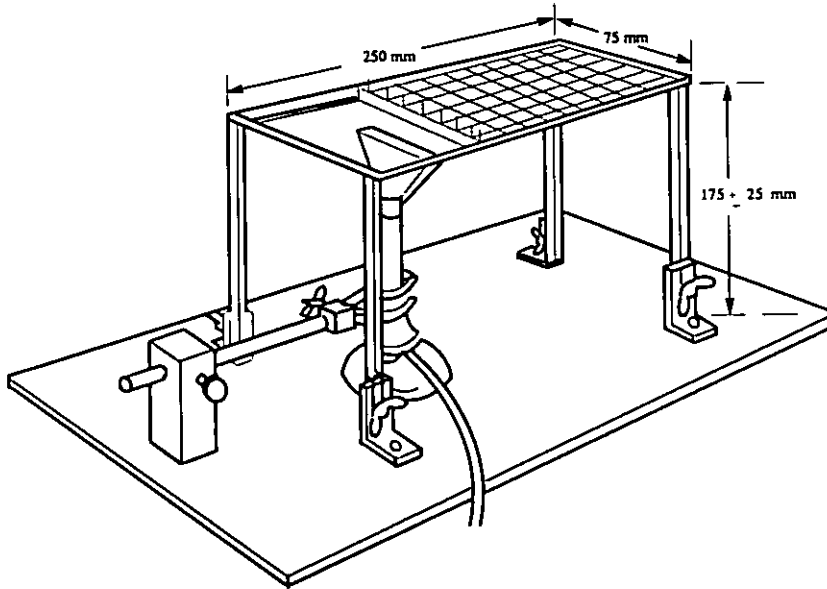

FIGURE 1. Apparatus for support of specimens.

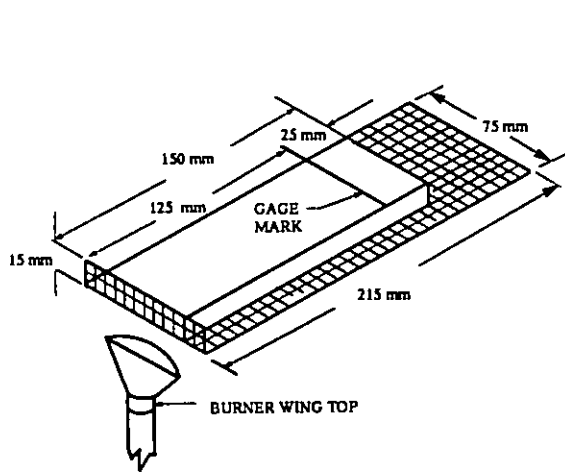

FIGURE 2. Relative positions of burner wing top, top, specimen, and specimen support.

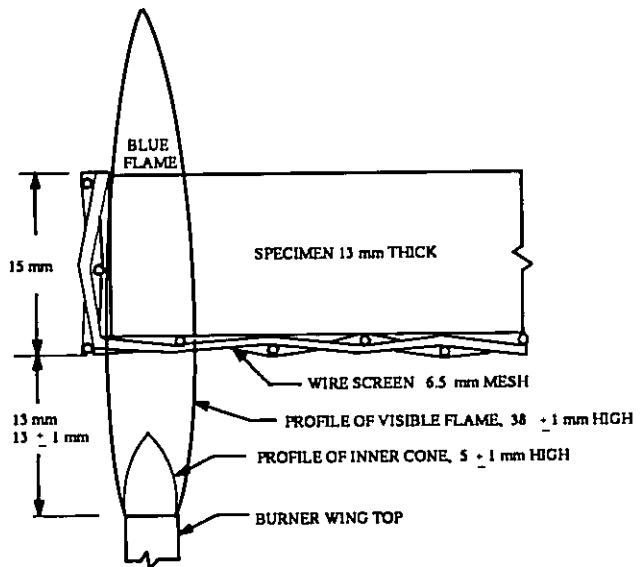

FIGURE 3. Relative positions of burner wing top, flame, specimen, and specimen support.

**MIL-F-87260(USAF)
APPENDIX C**

**STATIC CHARGE DISSIPATION TEST DATA CALCULATIONS
AND GRAPHICAL REPRESENTATION**

10. SCOPE

10.1 Scope. This appendix contains the guidelines for the calculation of the rate of power dissipation and the determination of the dissipation temperature limit.

20. APPLICABLE DOCUMENTS. This section is not applicable to this appendix.

30. CALCULATIONS

30.1 Calculations for the rate of power dissipation. The significant aspect of the conductive foam(s) is the rate of power dissipations (watts) as a function of temperature. This rate of power dissipation can be calculated at each temperature from the charge dissipation time (4.6.28) and the resistivity test results (4.6.23.3) using the following formula:

$$\text{POWER, } \omega(t) = \frac{V^2}{R} \times \frac{\tau}{2} \times 0.99 \quad (\text{TOTAL ENERGY})$$

where,

$\omega(t)$ = total energy dissipated in watts

τ = 0.4343 θ

θ = total time in seconds for the charge to dissipate from 5,000 volts to 500 volts

R = the materials resistivity at each temperature at which the charge dissipation tests were run

After the total energy dissipated, $\omega(t)$, has been determined, divide it by θ to give the rate of power dissipation at each test temperature.

40. DATA REPRESENTATION

40.1 Data representation. Sample data representation for the various test points should be presented in tabular form as shown in 20.1.

40.2 Typical tabular representation of data:

FOAM #1 - COARSE PORE IN-SITU

Temperature (°F)	ohm cm	discharge time (sec)	Tau, τ	watts/sec
0	1.7×10^{12}	10	4.343	3.10×10^{-6}
-5	2.8×10^{12}	17	7.38	1.89×10^{-6}
-10	4.3×10^{12}	25	10.85	1.24×10^{-6}
-20	7.0×10^{12}	46	19.9	0.76×10^{-6}
-30	30×10^{12}	380	165	0.18×10^{-6}

**MIL-F-87260(USAF)
APPENDIX C**

FOAM #2 - COARSE PORE IN-SITU

Temperature (°F)	ohm cm	discharge time (sec)	Tau, τ	watts/sec
32	0.7×10^{12}	4.4	1.9	7.6×10^{-6}
0	5×10^{12}	59.0	25.6	1.07×10^{-6}
-5	7×10^{12}	80.0	34.7	0.76×10^{-6}
-10	10×10^{12}	115.0	50	0.53×10^{-6}
-17	18×10^{12}	451.0	196	0.29×10^{-6}
-30	600×10^{12}	* at -18°F, the material no longer discharges		
-40	$>10^{15}$	* same as above		

FOAM #3 - ORANGE POLYESTER

Temperature (°F)	ohm cm	discharge time (sec)	Tau, τ	watts/sec
60	50×10^{12}	18	7.8	0.1×10^{-6}
40	70×10^{12}	64	28	0.07×10^{-6}
30	100×10^{12}	160.0	70	0.05×10^{-6}

Although these data are representative of the above foam types, it is recommended that several more data points for each foam type be obtained.

40.3 Typical graphical representation of data. The energy (watts/sec) dissipation rate as a function of temperature is shown on figure 1.

40.4 Determine the dissipation temperature limit as shown in the graph either by the change in slope method (foam #1) or by the intersection of the curve with the alternate lower limit line (foam #2).

MIL-F-87260(USAF)
APPENDIX CCONDUCTIVE FOAM CANDIDATES
ENERGY DISSIPATION RATE VS TEMPERATURE

FIGURE 1. Typical graphical representation of data (energy dissipation rate vs temperature)

STANDARDIZATION DOCUMENT IMPROVEMENT PROPOSAL

INSTRUCTIONS

1. The preparing activity must complete blocks 1, 2, 3, and 8. In block 1, both the document number and revision letter should be given.
2. The submitter of this form must complete blocks 4, 5, 6, and 7.
3. The preparing activity must provide a reply within 30 days from receipt of the form.

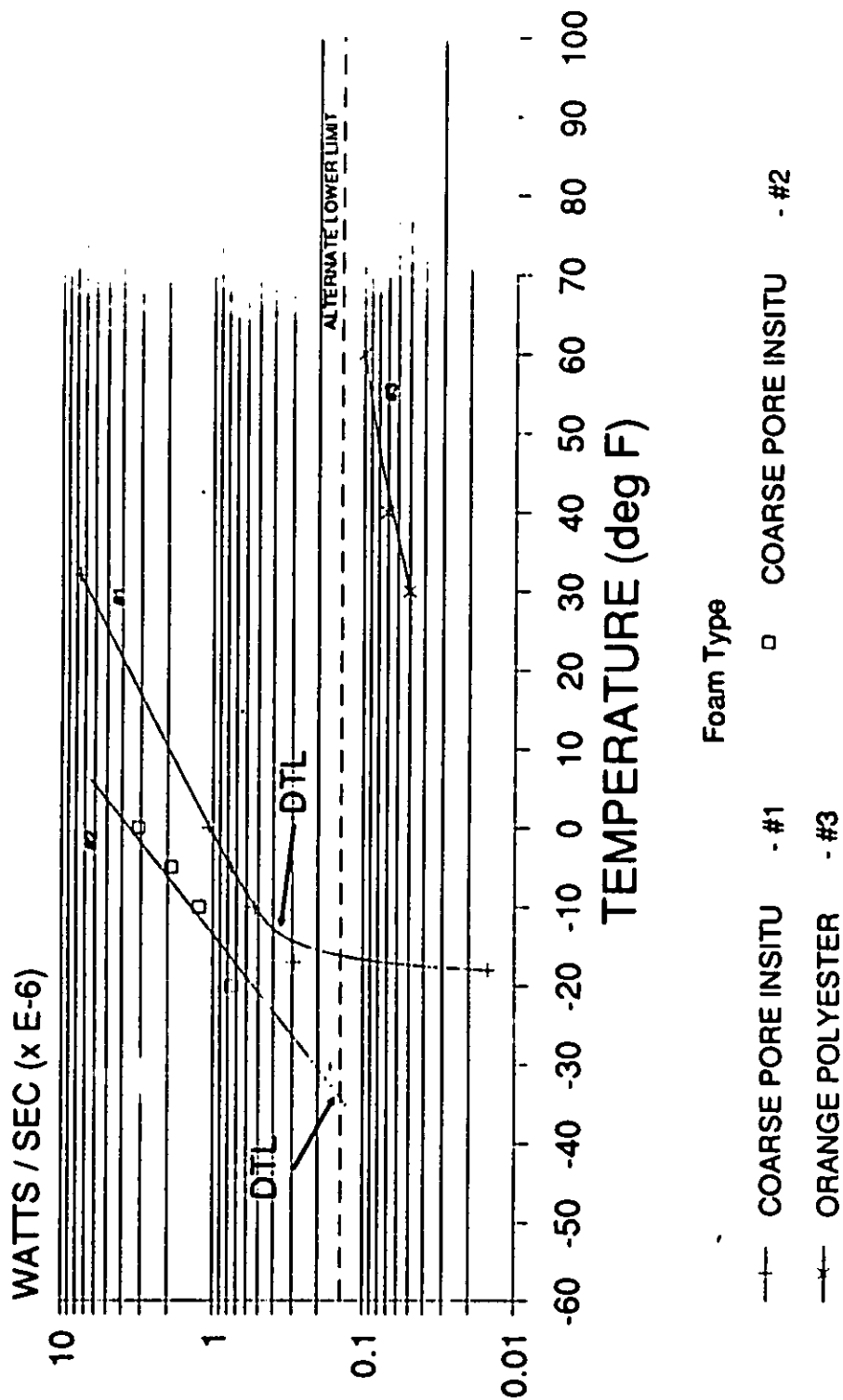
NOTE: This form may not be used to request copies of documents, not to request waivers, or clarification of requirements on current contracts. Comments submitted on this form do not constitute or imply authorization to waive any portion of the referenced document(s) or to amend contractual requirements.

I RECOMMEND A CHANGE:

1. DOCUMENT NUMBER
MIL-F-87260(USAF)2. DOCUMENT DATE (YYMMDD)
920207

3. DOCUMENT TITLE

Foam Material, Explosion Suppression, Inherently Electrically Conductive, for Aircraft Fuel Tank and Dry Bay Areas

4. NATURE OF CHANGE (Identify paragraph number and include proposed rewrite, if possible. Attach extra sheets as needed.)

5. REASON FOR RECOMMENDATION

6. SUBMITTER

a. NAME (Last, First, Middle Initial)

b. ORGANIZATION

c. ADDRESS (Include Zip Code)

d. TELEPHONE (Include Area Code)
(1) Commercial7. DATE SUBMITTED
(YYMMDD)(2) AUTOVON
(If applicable)

8. PREPARING ACTIVITY

A. NAME

ASD/ENES

B. TELEPHONE (Include Area Code)

(1) Commercial

(513) 255-6281

(2) AUTOVON (If applicable)

785-6281

C. ADDRESS (Include Zip Code)

ASD/ENES

Wright-Patterson AFB, OH 45433-6503

IF YOU DO NOT RECEIVE A REPLY WITHIN 45 DAYS, CONTACT:

Defense Quality and Standardization Office

5203 Leesburg Pike, Suite 1403, Falls Church VA 22041-3466

Telephone (703) 756-2340 AUTOVON 289-2340