

MIL-E-55119A(EL)**18 SEPTEMBER 1963****SUPERSEDING****MIL-E-55119(S1,C)****27 FEBRUARY 1961****MILITARY SPECIFICATION****ELECTRO-ACOUSTICAL TRANSDUCER EQUIPMENTS****1. SCOPE**

1.1 This specification covers the following electro-acoustical transducer equipments. Only those equipments specifically listed in the request for proposal and contract shall be furnished by the contractor (see 6.1 and 6.3)

Handset H-138()/GR
 Headset, Electrical H-139()/GR
 Headset, Electrical H-140()/GR
 Headset-Chestset, Electrical H-141()/GR
 Headset-Microphone H-161()/GR
 Handset H-207()/VRC
 Headset, Electrical H-227()/U
 Microphone, Dynamic M-80()/GR
 Microphone, Dynamic M-81()/GR
 Modification Kit, Electronic Equipment
 MK-567/G
 Headset-Microphone Kit MK-525()/G
 Headset-Microphone Kit MK-526()/G

2. APPLICABLE DOCUMENTS

2.1 The following documents, of the issue in effect on date of Invitation for Bids or request for proposal, form a part of this specification to the extent specified herein.

SPECIFICATIONS**FEDERAL**

PPP-B-585 — Boxes, Wood, Wirebound
 PPP-B-591 — Boxes, Fiberboard, Wood-Cleated
 PPP-B-601 — Boxes Wood Cleated
 PPP-B-621 — Boxes Wood Nailed and
 Lock-Corner.

PPP-B-636 — Boxes, Fiber, Solid.
 PPP-T-97 — Tape; Pressure-Sensitive Adhesive Filament Reinforced.

MILITARY

MIL-P-116 — Preservation, Methods of.
 MIL-B-10377 — Box, Wood, Cleated, Veneer, Paper-Overlaid.
 MIL-P-11268 — Parts, Materials and Processes Used in Electronic Communication Equipment.
 MIL-M-13231 — Marking of Electronic Items.
 MIL-F-14072 — Finishes for Ground Signal Equipment.
 MIL-C-55117 — Miniature Cable Assemblies for Audio Connectors.

STANDARDS**MILITARY**

MIL-STD-105 — Sampling Procedures and Tables for Inspection by Attributes.
 MIL-STD-129 — Marking for Shipment and Storage.
 MIL-STD-169 — Extreme Temperature Cycle.
 MIL-STD-170 — Moisture Resistance Test Cycle for Ground Signal Equipment.
 MIL-STD-202 — Test Methods for Electronic and Electrical Components Parts.

MIL-E-55119A(EL)

MIL-STD-252 — Wired Equipment, Classification of Visual and Mechanical Defects.

DRAWINGS**NAVY**

SK-N-864 — Simulated Gun Blast Producing Equipment.

ELECTRONICS COMMAND

SC-DL-68417 — Plug Connector U-161()/U.

SC-DL-164943 — Headset-Microphone Kit MK-525()/G.

SC-DL-164944 — Headset-Microphone Kit MK-526()/G.

SC-A-362100 — Preparation of Preproduction Packs.

SC-DL-415575 — Handset H-207()/VRC.

SC-DL-436100 — Headset Microphone H-161.

SC-DL-436133 — Bail Out Connector (Lower).

SM-D-436135 — Chest Switch Assembly.

SC-DL-436200 — Headset Electrical H-140A/U.

SM-D-436220 — Earphone and Cup Assembly.

SM-C-436230 — Headband, Sub-Assembly.

SC-DL-436250 — Microphone Dynamic M-80/U.

SM-C-436270 — Microphone Assembly.

SC-DL-436300 — Modification Kit Electronic Equipment MK-567/G.

SM-D-436304 — Bail Out Connector (Upper).

SC-DL-436331 — Plug Connector U-182()/U.

SC-DL-448300 — Handset, Electrical H-138()/GR.

(Copies of specifications and standards required by contractors in connection with specific procurement functions should be obtained from the procuring activity or as directed by the contracting officer. Both the title and number or symbol should be stipulated when requesting copies.)

2.2 Other publications. The following documents form a part of this specification to the extent specified herein. Unless otherwise indicated, the issue in effect on date of invitation for bids or request for proposal shall apply.

AMERICAN STANDARDS ASSOCIATION.

ASA Z24.9-1949 — Coupler Calibration of Earphones.

ASA Z24.4-1949 — Pressure Calibration of Laboratory Standard Pressure Microphone.

(Application for copies should be addressed to the American Standards Association, Inc., 10 East 40th Street, New York 16, N.Y.)

3. REQUIREMENTS**3.1 Description.**

(a) **Headset, Electrical H-139/GR** is a single earphone headset with a flexible headband and fold-away earphone, intended for use in low and medium ambient noise areas. The earphone assembly employs a dynamic earphone, impedance matching transformer, attenuation plate and an ear cushion. The earphone through the matching transformer is connected to a retractile cord which is terminated in Connector U-182()/U and the terminal impedance is 1000 ohms.

(b) **Headset, Electrical H-140()/GR** is a double earphone headset with a flexible headband intended for use in medium and high ambient noise areas. The earphone assemblies are identical to those in the H-139()/GR, H-141()/GR and H-161()/GR. The impedance matching transformers are connected to a retractile cord which is terminated in Connector U-182()/U and the terminal impedance is 500 ohms.

(c) **Headset-Chestset H-141()/GR** is a double earphone headset-chestset with a flexible headband for use in medium and high ambient noise areas. The chestset is a neck-strap suspended, hand-held switch and noise-cancel-

MIL-E-55119A(EL)

ling dynamic microphone with a matching transformer and retractile cord having a bail-out connector. The transformer is enclosed internally in the microphone element. The switch provides positions of "lock-on" INTERCOM, CENTER OFF, and "hold-on" RADIO. The earphone assemblies and chestset terminate in a bail-out connector which mates with a retractile cord terminated in two Connectors U-182()/U, the terminal impedance of which are 500 and 150 ohms for earphone and microphone respectively.

- (d) Headset-Microphone H-161()/GR is a double earphone headset-microphone-chestset combination with a flexible headband boom microphone and a neck-strap suspended, hand-held chestset. The chestset switch, earphone assemblies and microphone are identical to those in the H-141()/GR equipment. The earphone and microphone assemblies connect to a molded jack which is connected to a retractile cord terminated like the H-141()/GR equipment.
- (e) Microphones M-80()/GR and M-81()/GR are palm-held, dynamic type units with a push-to-talk switch incorporated in the microphone handle. Microphone M-80()/GR has a noise cancelling feature; Microphone M-81()/GR does not. The microphones are equipped with a four conductor retractile cord terminated with Connector U-182()/U, and a clip for attaching the microphone to the user's clothing or a radio set. Both microphones are blast-resistant and watertight.
- (f) Handset H-138()/GR is a noise-cancelling dynamic handset consisting of five major components; earphone, microphone push-to-talk

switch, retractile cord terminated with Connector U-182()/U and handle.

- (g) Headset-Microphone Kit MK-525()/G and Headset-Microphone Kit MK-526()/C. Each kit consists of two earphones, two ear cushions, a microphone, a boom, switching facilities, cords, connectors, and mounting hardware. The earphone elements are waterproof, dynamic and blast proof. The microphone is dynamic, noise cancelling waterproof and blastproof. Headset-Microphone Kit MK-525()/G will be installed in a regular size Helment, Combat Vehicle Crewman T-56-6 and Headset-Microphone Kit MK-526()/G will be installed in a larger size Helment, CVC-T56-6.
- (h) Handset H-207()/VRC is a noise cancelling dynamic handset consisting of five major components, earphone, microphone, push-to-talk switch and retractile cord 48" long extended terminated with 5 spade lugs".
- (i) Headset, Electrical H-227()/U is a double earphone headset with a flexible headband. This headset is identical to Headset, Electrical H-140()/GR except that Plug, Connector U-161 replaces Plug Connector U-182/U.

3.2 Construction.

- (a) *Models.* A model of the equipment will be available for inspection by prospective bidders and will be loaned to the contractor for the following equipments:
- * Headset, Electrical H-139()/GR
 - * Headset-Chestset, Electrical, H-141()/GR
 - * Headset, Electrical H-227()/U
 - * Microphone, Dynamic M-81()/GR

* *Note* Asterisked items shall be constructed in accordance with the models except for the following components which shall be constructed in accordance with the indicated drawings

MIL-E-55119A(EL)**1. Headset, Electrical H-139()/GR**

Drawings SC-DL-436200 covering Headset Electrical H-140()/U shall apply except that headband using a single earphone shall be in accordance with the model

2. Headset-Chestset H-141()/GR

Drawings SM-D-436220—Earphone and Cup Assembly.

Drawings SM-C-436270—Microphone Assembly.

Drawings SM-D-436135—Chest Switch Assembly

Drawings SM-C-436230—Headband Assembly.

SM-D-436304—Bail Out Connector (Upper)

SM-D-436331—Plug Connector U-182()/U

SM-D-436133—Bail Out Connector (Lower)

All the other parts of the H-141()/GR shall be in accordance with the model

3. Headset, Electrical H-227()/U.

Drawings SC-DL-436200 covering Headset, Electrical H-140()/G shall apply except that Plug Connector U-161()/U in accordance with SC-DL-68417 shall be used instead of Plug Connector U-182()/U

4. Microphone, Dynamic M-81()/GR

Drawings SC-DL-436250 covering Microphone, Dynamic M-80()/U shall apply except that the noise canceling feature be in accordance with the model.

Unless otherwise specified herein or in the invitation for bids, physical construction of the equipment shall incorporate all features of the model (NOTE: In case of conflict between specified performance characteristics for the equipment and the performance of the model, the specified performance characteristics govern.)

(b) The following equipments shall be constructed in accordance with drawings as listed on the Drawing and Data Lists as follows:

SC-DL-164943 Headset-Microphone Kit
MK-525()/G.

SC-DL-164944 Headset-Microphone Kit
MK-526()/G.

SC-DL-415575 Handset
H-207()/VRC.

SC-DL-436100 Headset Microphone
H-161.

SC-DL-436200 Headset Electrical
H-140A/U.

SC-DL-436250 Microphone Dynamic
M-80/U.

SC-DL-436300 Modification Kit,
Electronic Equipment
MK-567/G.

SC-DL-448300 Handset, Electrical
H-138()/GR.

3.3 Parts, materials and processes; general.

In addition to the requirements of this specification, the requirements of Specification MIL-P-11268 including the selection requirements therein, shall apply.

3.3.1 Magnetized materials. The materials used in the magnetic circuit shall be of such a character and shall be so processed and assembled that the microphone and earphone elements will not suffer objectional degradation in performance due to loss in magnetization over long periods of storage or service.

3.3.2 Diaphragm and air gap. The stability of diaphragm material and the concentricity of the air gap shall not be affected by extended aging and exposure to environmental conditions. There shall be no foreign material present in the air gap.

3.4 Finish. Equipment shall be finished in accordance with Specification MIL-F-14072

3.5 Marking. Marking shall conform to Specification MIL-M-13231

3.5.1 Serial numbers Serial numbers are not required.

3.6 Microphone.

3.6.1 Microphone response. The frequency response of the microphone (with transformer) shall be essentially flat from 300 to 3500 cps. The minimum power output of the microphone shall be -56 dbm at 1000 cps when measured in accordance with 4.7.1. In addition the response shall fall within the envelope of figure 1. During this test, the microphone shall be terminated with a noninductive load of 150 ohms.

3.6.2 Distortion. Total harmonic distortion shall not exceed 5 percent of a sound pressure

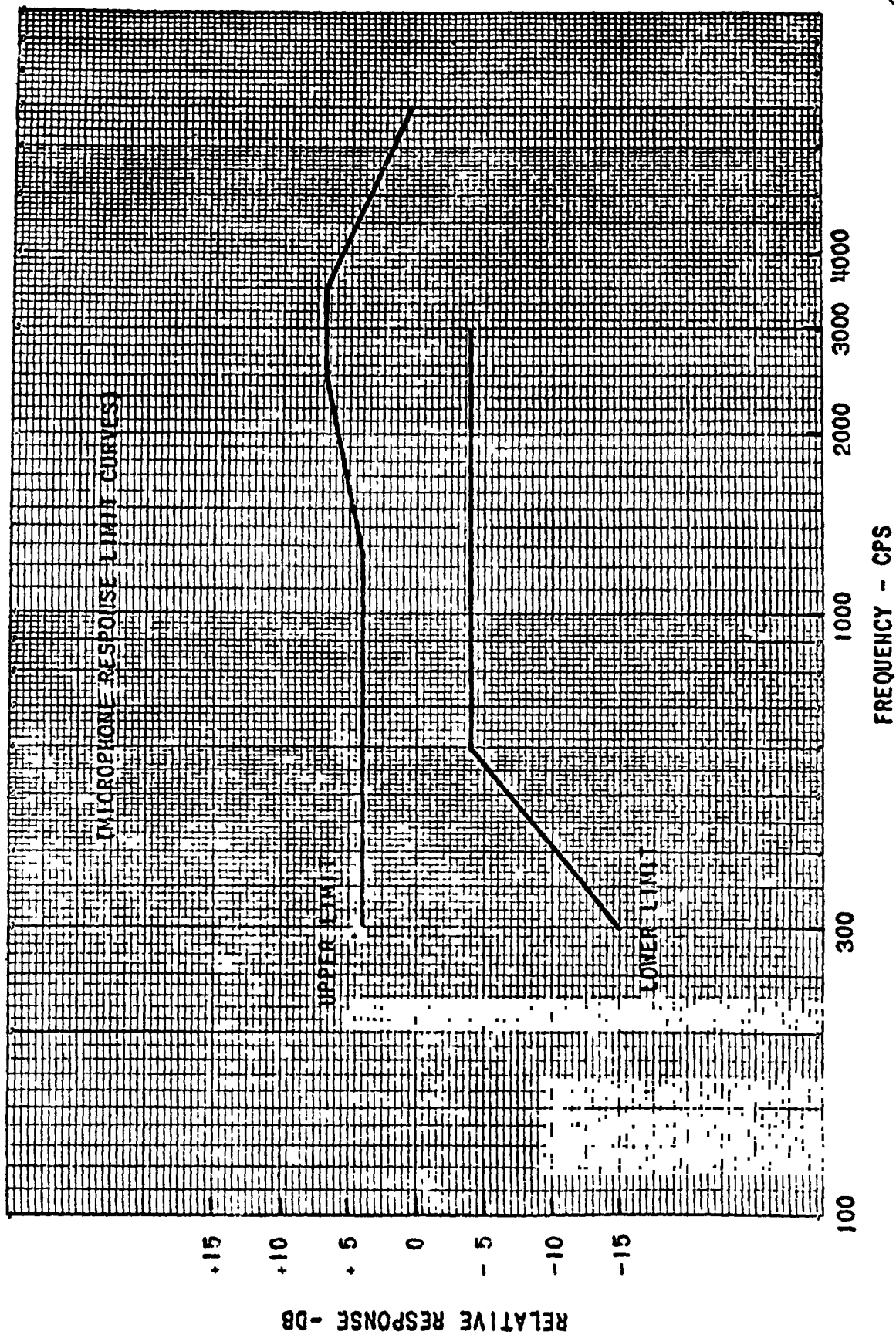

FIGURE 1

MIL-E-55119A(EL)

level of 125 db referenced at .0002 dynes per square centimeter over the frequency range of 300 to 3500 cps.

3.6.3 Signal-to-noise ratio. The signal-to-noise ratio of the microphone shall be at least 15 db (signal over noise) when measured in accordance with 4.7.3.3.

3.6.4 Dielectric strength, and insulation resistance. There shall be no evidence of insulation breakdown when the microphone is subjected to an a.c. voltage of 500 volts rms, 60 cycle for 10 seconds applied between the terminals of the microphone and the insulated outer metal parts of the microphone. The insulation resistance shall exceed one megohm between the indicated points following the application of this voltage (see 4.7.4).

3.7 Earphone.

3.7.1 Earphone response. The output of the earphone shall be not less than 103 db above a reference level of 0.0002 dyne per square centimeter when 1 milliwatt rms power at 1000 cps is applied to the earphone terminals. The response of the earphone at any frequency shall not deviate from the 1000 cps response by more than the values shown in Table I.

TABLE I.

Frequency (in cps)	Deviation from 1000 cps (in db)	
	Min	Max
300-1000	-3.5	+1.5
1000-3500	-5	+5

3.7.2 Distortion. The acoustic output of the earphone shall have no more than 5 percent total harmonic distortion over the audio frequency range of 300 to 3500 cps, when measured as specified in 4.8.3.

3.7.3 Overload. The earphone shall show no more than 3 db change from its original response curve, after being subjected to the test specified in 4.8.4.

3.7.4 Dielectric strength and insulation resistance. The insulation between the earphone terminals and exposed metal parts shall withstand 500 volts rms, 60 cycle ac for 10 seconds without breakdown. The insulation resistance shall exceed one megohm between the indicated points following the application of this voltage (see 4.8.5).

3.7.5 Impedance. The impedance of the earphone at 1000 cps shall be 15 ohms plus or minus 20 percent, as determined by the test of 4.8.2. For Handset H-138()/GR, the impedance of the earphone measured at Connector Plug U-182()/U shall be 1000 ohms \pm 20 percent.

3.8 Service conditions. The equipment shall meet the following service conditions where a test is referenced, meeting the test shall be considered as compliance with requirement.

3.8.1 Temperature (see 4.13.1).

(a) *Operating:* Ambient temperature in the range of +150°F. to -40°F. (The 150°F. temperature includes effect of sunload). Exposure at the high temperature extreme not to exceed 4 hours, and at the low temperature extreme not to exceed 72 hours, at any one time.

(b) *Nonoperating:* Exposure in the range of +160°F. to -80°F.; exposure at the high temperature extreme not to exceed 4 hours and at the low temperature extreme not to exceed 24 hours

3.8.2 Relative humidity (see 4.13.2). Up to 97 percent relative humidity for 20 hours; and exposure at 100 percent relative humidity with condensation for 4 hours.

3.8.3 Elevation (see 4.13.3).

(a) *Operating:* Up to 15,000 feet above sea level.

(b) *Nonoperating:* Up to 50,000 feet above sea level

3.8.4 Immersion (see 4.13.4). Three feet of water for 2 hours.

3.8.5 Salt spray (see 4.13.5). Twenty percent salt solution at 96°F. for 48 hours.

3.8.6 Blast (see 4.13.6). Thirty rounds of blast at a peak pressure of 9.5 pounds per square inch with no more than 3 db degradation in performance.

3.8.7 Vibration (see 4.13.7). The amplitude of vibration of any part, subassembly, or structural member of the equipment shall not exceed twice the amplitude of the vibration applied to the

equipment at any frequency between 10 and 55 cycles per second

3.8.8 Bounce (see 4.13.8). The equipment shall meet specified performance, with no physical damage allowed, after subsection to the test of 4.13.8.

3.8.9 Shock drop (see 4.13.9). The equipment shall be operable after the test of 4.13.9. Any physical damage shall be minor only.

3.9 Switch.

3.9.1 Push-to-talk switch (H-138()/GR, M-80()/GR, M-81()/GR). The switch shall be a push-to-talk switch which shall be capable of 500,000 operations, at a rate not to exceed 1 cycle per second, with a current of ½ ampere (24 volt supply) flowing through the control circuit in series with a resistive load. The switch contacts shall "make" in sequence (microphone circuit first, then control circuit). The control circuit contacts shall "break" before the microphone circuits (see 4.12.1)

3.9.2 Toggle switch H-139()/GR, H-140()/GR, H-141()/GR, H-161()/GR. The switch shall be a toggle switch capable of 100,000 complete cycles of operation when tested as specified in 4.12.2.

3.9.3 Level switch (MK-525()/G and MK-526()/G. The switch shall be capable of 100,000 complete cycles of operation when tested as specified in 4.12.3

3.10 Cord assemblies. Cord assemblies shall be in accordance with Specification MIL-C-55117.

3.11 Operational requirement. Headsets shall be tested as indicated in paragraph 4.9.

3.12 Interchangeability. Like units, assemblies, subassemblies, and replaceable parts shall be physically and functionally interchangeable, without modification of such items or of the equipment. (See 4.11.) Individual items shall not be handpicked for fit or performance. Reliance shall not be placed on any unspecified dimension, rating, characteristic, etc.

3.13 Preconditioning. The equipment shall be capable of meeting the requirements herein,

without subsequent processing, after subsection to the bounce preconditioning of 4.6 (also 4.5).

3.14 Preproduction samples. Unless otherwise specified in the bid request and contract, the contractor shall furnish 12 each preproduction samples of each type of electro-acoustical transducer on order.

3.15 Workmanship. The equipments shall be manufactured and assembled in accordance with the applicable portions of the following paragraphs:

- (a) In Specification MIL-P-11268:
 - General requirements of plastic material and parts.
 - Wiring and cabling, including—
 - Clearance
 - Splicing
 - Connections, general
 - Grounding, general
 - Flux and cleaning agents for soldering.
 - Process for soldering
 - Cleaning of equipment
 - Riveting
 - General Process for securing parts
- (b) In this specification—
 - 3.3.1 Magnetized materials
 - 3.3.2 Diaphragm and air gap

4. QUALITY ASSURANCE PROVISIONS

4.1 Responsibility for inspection. Unless otherwise specified in the contract or purchase order, the supplier is responsible for the performance of all inspection requirements as specified herein. Except as otherwise specified, the supplier may utilize his own facilities or any commercial laboratory acceptable to the Government. The Government reserves the right to perform any of the inspections set forth in the specification where such inspections are deemed necessary to assure that supplies and services conform to prescribed requirements.

4.2 Classification of inspection. Inspection shall be classified as follows:

- (a) Preproduction inspection (does not include preparation for delivery) (see 4.3).
- (b) Inspection covered by subsidiary documents (see 4.4).

MIL-E-55119A(EL)**TABLE II Preproduction inspection**

Inspection	Req para.	Insp. para.
Temperature	3.8.1	4.13.1
Moisture resistance	3.8.2	4.13.2
Altitude	3.8.3	4.13.3
Salt spray	3.8.5	4.13.5
Blast	3.8.6	4.13.6
Vibration	3.8.7	4.13.7
Bounce	3.8.8	4.13.8
Shock, drop	3.8.9	4.13.9

(c) Quality conformance inspection.

- (1) Quality conformance inspection of equipment before preparation for delivery (see 4.5).
- (2) Quality conformance inspection of preparation for delivery (see 4.14).

4.3 Preproduction inspection. This inspection will be performed by the Government unless otherwise specified in the contract. It shall consist of the preproduction inspection specified in table II, the inspection specified in the subsidiary documents covering the items listed in 4.4, and the inspection specified for Group A, and Group B, and Group C (see table III, and IV, and V, respectively). The preproduction inspection will normally be performed in this order: (1) vibration, (2) bounce, (3) shock, drop, and (4) immersion; other preproduction inspection may

precede, follow, or be interspersed among the foregoing.

4.4 Inspection covered by subsidiary documents. The following shall be inspected under the applicable subsidiary documents as part of the inspection of equipment before preparation for delivery:

Item	Where required
Finish	3.4
Marking	3.5
Cord assemblies	3.10

4.5 Quality conformance inspection of equipment before preparation for delivery.

The contractor shall perform the inspection specified in 4.4 and 4.5.1 through 4.5.4. This does not relieve the contractor of his responsibility for performing any additional inspection which is necessary to control the quality of the product and to assure compliance with all specification requirements. The Government will review and evaluate the contractor's inspection procedures and examine the contractor's inspection records. In addition the government—at its discretion—may perform all or any part of the specified inspection, to verify the contractor's compliance with specified requirements (See 6.5.) Test equipment for Government verification inspection shall be made available by the contractor. Each unit which will be subjected to group A, group B, or group C inspection, except preproduction samples, shall be preconditioned after final assembly (see 3.12).

TABLE III. Group A inspection

Inspection	Req para	Insp para	AQL	
			Major	Minor
<i>Visual and mechanical</i>	3.15	4.10	10%	40%
<i>Microphone</i>				
Response	3.6.1	4.7.1	1.0% for the combined group	*
Dielectric strength and insulation resistance	3.6.4	4.7.4		
<i>Earphone</i>				
Responses	3.7.1	4.8.1	10% for the combined group	*
Impedance	3.7.5	4.8.2		
Dielectric strength and insulation resistance	3.7.4	4.8.5		
<i>Operational</i>	3.11	4.9	10%	*

* All electrical and operational defects are considered major

Note: Operational inspection shall be performed prior to packaging.

MIL-E-55119A(EL)

4.5.1 Group A inspection This inspection, including sampling, shall conform to table III and the ordinary inspection procedures of Standard MIL-STD-105. Group A inspection shall be performed in any order which is satisfactory to the Government.

4.5.2 Group B inspection. This inspection, including sampling, shall conform to table IV and to the special procedures for small-sample inspection of Standard MIL-STD-105. The AQL shall be as shown in table IV and the inspection level shall be L-7 for normal and tightened inspection and L-5 for reduced inspection. The reduced inspection procedure shall be R-1. Group B inspection normally shall be performed on inspection lots that have passed group A inspection and on samples selected from units that have been subjected to and met the group A inspection.

TABLE IV Group B inspection

Inspection	Req para	Insp para	AQL
Signal-to-noise ratio	3 6 3	4 7 3 3	6 5%
<i>Distortion</i>			
Microphone	3 6 2	4 7 2	6 5%
Earphone	3 7 2	4 8 3	6 5%
Dimensional			
interchangeability	3 1 2	4 1 1	6 5%
Immersion	3 8 4	4 1 3 4	6 5%

4.5.3 Group C inspection This inspection shall be as listed in table V, and shall be performed on sample units that have been subjected to and met group A and group B inspection.

TABLE V Group C inspection .

Inspection	Req para	Insp para
Overload	3 7 3	4 8 4
Life (switch)	3 9	4 1 2

4.5.3.1 Sampling for inspection of equipment Four of each type unit and two switches for each group C inspection shall be selected from each 500 units without regard of each type to their quality, except that the units inspected at the start of the contract shall be selected from the first units produced

4.5.3.2 Noncompliance. If a sample unit fails group C inspection, the contractor shall immediately investigate the cause of failure and shall report to the Government inspector the result thereof and details of the corrective action taken on the process and all units of product which were manufactured with the same conditions, materials, processes, etc. If the Government inspector does not consider that the corrective action will enable the product to meet specified requirements, or if the contractor cannot determine the cause of failure, the matter shall be referred to the contracting officer (see 6.4).

4.5.4 Reinspection of conforming group B and group C sample units. Unless otherwise specified sample units which have been subjected to and passed group B or group C inspection, or both, may be accepted on contract, provided that they are resubjected to and pass group A inspection after repair of all visible damage.

4.6 Bounce preconditioning. The unit shall be placed in its normal operation position on the table of the Package Tester, Type 1000-SC, as made by the L.A.B Corporation, Skaneateles, New York, or equal. The package tester, shafts in phase, shall have a speed such that it is just possible to insert a $\frac{3}{32}$ inch-thick strip of material under one corner or edge of the unit to a distance of 3 inches as the unit bounces. The unit shall be subjected to this preconditioning for 1 minute. After bounce preconditioning, the unit shall not be repaired, aligned, cleaned, or otherwise changed prior to subjection to quality conformance inspection.

4.7 Microphone tests.

4.7.1 Response test The response of the microphone shall be measured by means of a suitable a-c electronic voltmeter, having an input impedance of at least $\frac{1}{2}$ megohm. The response of the microphone shall be determined using a constant sound pressure of 28 dynes per square centimeter at the point where the microphone is to be placed. The driver unit used to obtain the desired sound pressure input, (Western Electric Co., Type No 555W, or equal) shall have been previously calibrated by means of a condenser microphone such as Western Electric Co 640AA, or equal, (calibrated by "reciprocity method" in

MIL-E-55119A(EL)

accordance with A.S.A. Standard Z24 4-1949 "Pressure Calibration of Laboratory Standard Pressure Microphones"). The sample dynamic microphone shall be positioned with its face $\frac{1}{4}$ inch directly in front of the driver unit with the diaphragm of the microphone parallel to the driver unit. The voltage—frequency response of the microphone (with transformer) shall be measured across a noninductive load resistance of 150 ohms. The response of the microphone shall be tested in the frequency range of 300 to 3500 cycles per second at approximately the following increments: 100 cps increments from 300 to 1000 cps and 250 cps increments from 1000 to 3500 cps. The microphone shall meet the requirements of 3.6.1.

4.7.2 Distortion Harmonic distortion shall be determined using the same equipment and circuitry as used in 4.7.1 except that the constant sound pressure shall be 125 db referenced at .0002 dynes per square centimeter and the output of the microphone terminated in 150 ohms shall be connected to a Hewlett Packard Distortion Analyzer Model 330C, or equal, for distortion measurements. The distortion shall not be greater than 5 percent. Measurements will be made from 300 cps to 1000 cps inclusive at each 1000 cps increment and from 1000 to 3500 cps inclusive at each 50 cps increment.

4.7.3 Signal-to-noise ratio

4.7.3.1 Noise spectrum. By means of apparatus detailed in figure 2, and the test circuit of Figure 3, provision shall be made for the production of the noise spectrum, table VI, at an rms sound pressure of 115 db above a reference level of .0002 dyne per square centimeter as measured at the microphone diaphragm. The "Noise" source shall incorporate a loudspeaker capable of producing a sound pressure of 115 db above a reference level of 0.0002 dyne per square centimeter at the rear, as well as the front of the microphone. The loudspeaker shall be located as far away from the microphone as practicable. The calibrating condenser microphone shall be mounted in the test rig, in the box, $\frac{1}{4}$ inch from the mouth of the signal speaker, which shall be short-circuited during adjustments of the noise spectrum.

TABLE VI NOISE SPECTRUM

Frequency in CPS	Sound Pressure in DB Relative to Sound Pressure at 150 CPS
40	0
70	0
150	0
300	-5
600	-9
1000	-13
2000	-17
3000	-19
4000	-21

4.7.3.2 Signal spectrum. By means of the apparatus as set up previously, provision shall also be made for the production of the following signal spectrum, table VII at an rms sound pressure of 115 db above a reference level of 0.0002 dyne per square centimeter. The "signal" source shall be the driver unit. The calibrating condenser microphone shall be positioned $\frac{1}{4}$ inch directly in front of the driver unit.

TABLE VII. SIGNAL SPECTRUM

Frequency in CPS	Sound Pressure in DB Relative to Sound Pressure at 150 CPS
150	0
300	+7
600	+8
1000	+5
2000	-3
3000	-7
4000	-9

4.7.3.3 Measurement of the signal-to-noise ratio. The microphone shall be mounted in its test rig with its front grid $\frac{1}{4}$ -inch from the mouth of the "signal" speaker. The microphone shall be connected to the test circuit shown in figure 3. The noise spectrum shall be applied for 3 seconds, and the output of the microphone shall be measured. The noise spectrum shall be removed, and the signal spectrum shall be applied for 3 seconds. The output of the microphone shall be measured. The db difference between the "signal" value and the "noise" value is the signal-to-noise ratio, and shall be in accordance with 3.6.3.

4.7.4 Dielectric strength and insulation resistance test. The microphone shall be tested for compliance with 3.6.4.

MIL-E-55119A(EL)

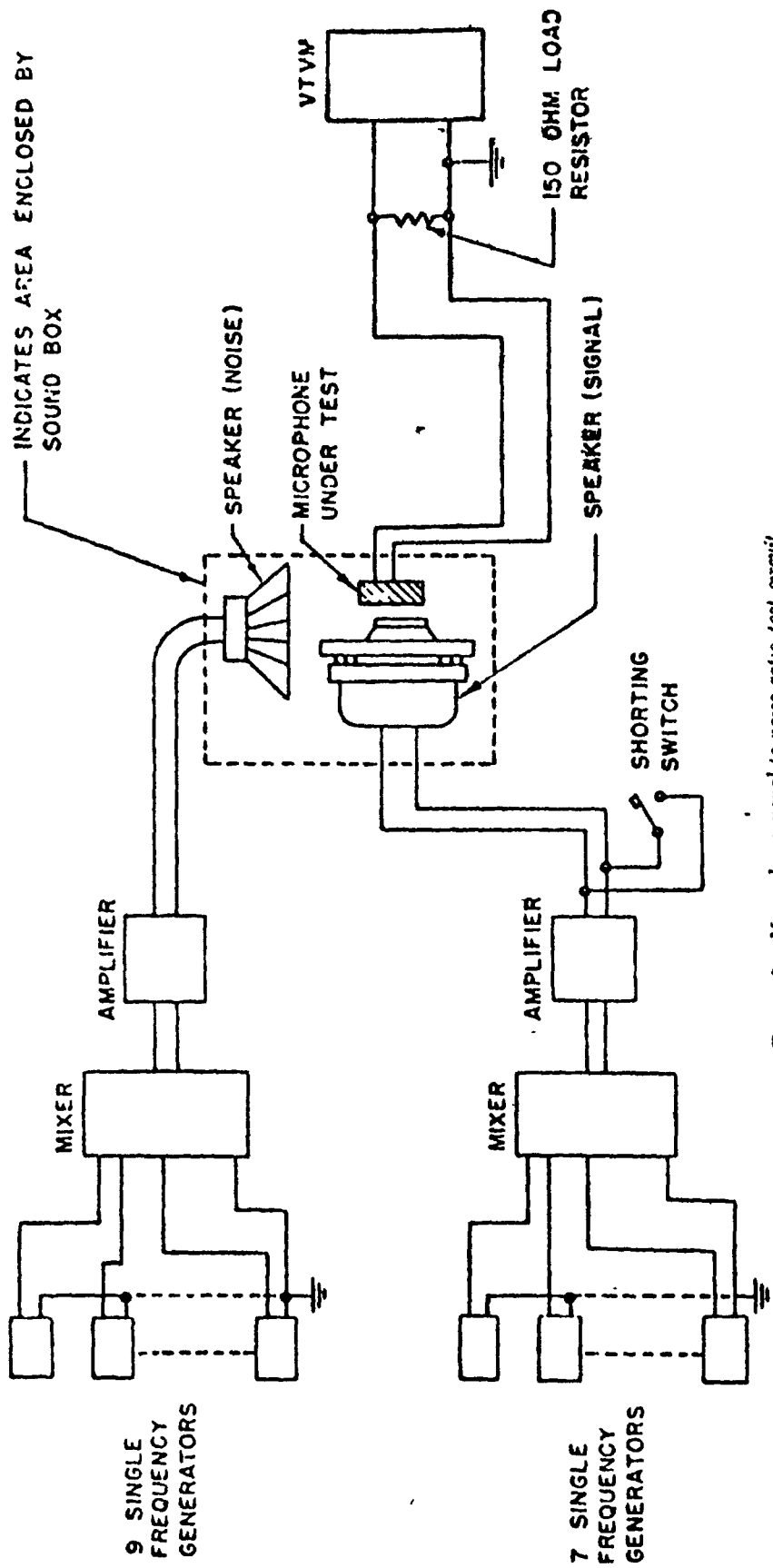

FIGURE 3 Microphone signal-to-noise ratio test circuit.

MIL-E-55119A(EL)**4.8 Earphone tests.**

4.8.1 Earphone response test Available-power frequency response measurements shall be made starting at 300 cycles and extending through 3500 cycles, in sufficient detail to establish definitely the shape of the curve. Response measurements shall be made in accordance with "Coupler Calibration of Earphones," "A.S.A. Standard Z24.9-1949. The contractor shall supply a 6 cc coupler. The outside dimensions of the coupler shall be such as to provide the proper seating and sealing of the earphone.

4.8.1.1 Testing procedure The earphone under test shall be connected to the test circuit and shall be mounted on the 6 cc coupler as shown in figure 4. The output from the oscillator at each test frequency shall be adjusted to 0.245 volts rms as measured by VTVM #1. The output from the calibrated microphone and pre-amplifier unit shall be measured as indicated by the reading of VTVM #2. This reading shall be converted to the equivalent db value above 0.0002 dyne per square centimeter using the most recent available calibration curve for the test microphone in use. The operations set forth above shall be performed from 300 cps to 100 cps inclusive, with measurements at each increment of 100 cps, and from 1000 cps to 3500 cps inclusive, with measurements at each increment of 250 cps. The response of the earphone shall meet the requirements specified in 3.7.1.

4.8.1.2 Test equipment The test equipment used for the response test shall meet the following requirements:

(a) *Calibrating microphone.* A Western Electric Co 640AA condenser microphone, or equal shall be used for measuring sound pressure. It shall be calibrated by the reciprocity method in accordance with A.S.A. Standard Z24.4-1949 Pressure Calibration of Laboratory Standard Pressure Microphones.

(b) *Audio oscillator* The audio oscillator shall have a frequency range of at least 100 to 10,000 cps shall have a high degree of stability in both output voltage and frequency, and shall have

a waveform distortion of less than 2 percent

(c) *Vacuum-tube voltmeter* The vacuum-tube voltmeters used must have flat frequency response (± 1 db) from at least 100 to 10,000 cps and must be capable of measuring voltage from 0.001 volt rms to 10 volts or more.

(d) *Microphone pre-amplifier.* The microphone preamplifier shall have a flat response (± 1 db) over a frequency range of at least 100 to 10,000 cps, shall have a high degree of stability, and shall have distortion of less than 2 percent.

4.8.2 Impedance The impedance of the earphone shall be measured with 0.122 volt at 1000 cps applied to the earphone terminals. The impedance shall be determined either by measuring the voltage across and the current through the earphone or with an impedance bridge. The impedance of the earphone when mounted on the coupler shall meet the requirements of 3.7.5. In addition, the impedance of the earphone of Handset H-138()/GR shall be measured at Connector Plug U-182()/U with 1.0 volt at 1000 cps being applied.

4.8.3 Distortion test The earphone shall be mounted on the 6 cc coupler, and shall be connected to the test circuit described in 4.8.1.1. The output of the oscillator shall be adjusted to 2.12 volts rms at 300 cps across the series combination of the 15 ohm resistor and the earphone. The rms harmonic distortion shall be measured with a Hewlett-Packard Model 330-C Total Noise Distortion Meter, or equal connected across the output of the microphone referenced in 4.8.1. The distortion measurement shall be repeated at 400 cps and at sufficient points between 400 and 3500 cps to determine the frequency where maximum distortion exists. Total harmonic distortion shall meet the maximum requirements of 3.7.2.

4.8.4 Overload After operation of the earphone for 8 hours with 500 milliwatts input power (2.74 volts) at 1000 cps, the response shall be tested per 4.8.1 to establish compliance with the requirements of 3.7.3.

MIL-E-55119A(EL)

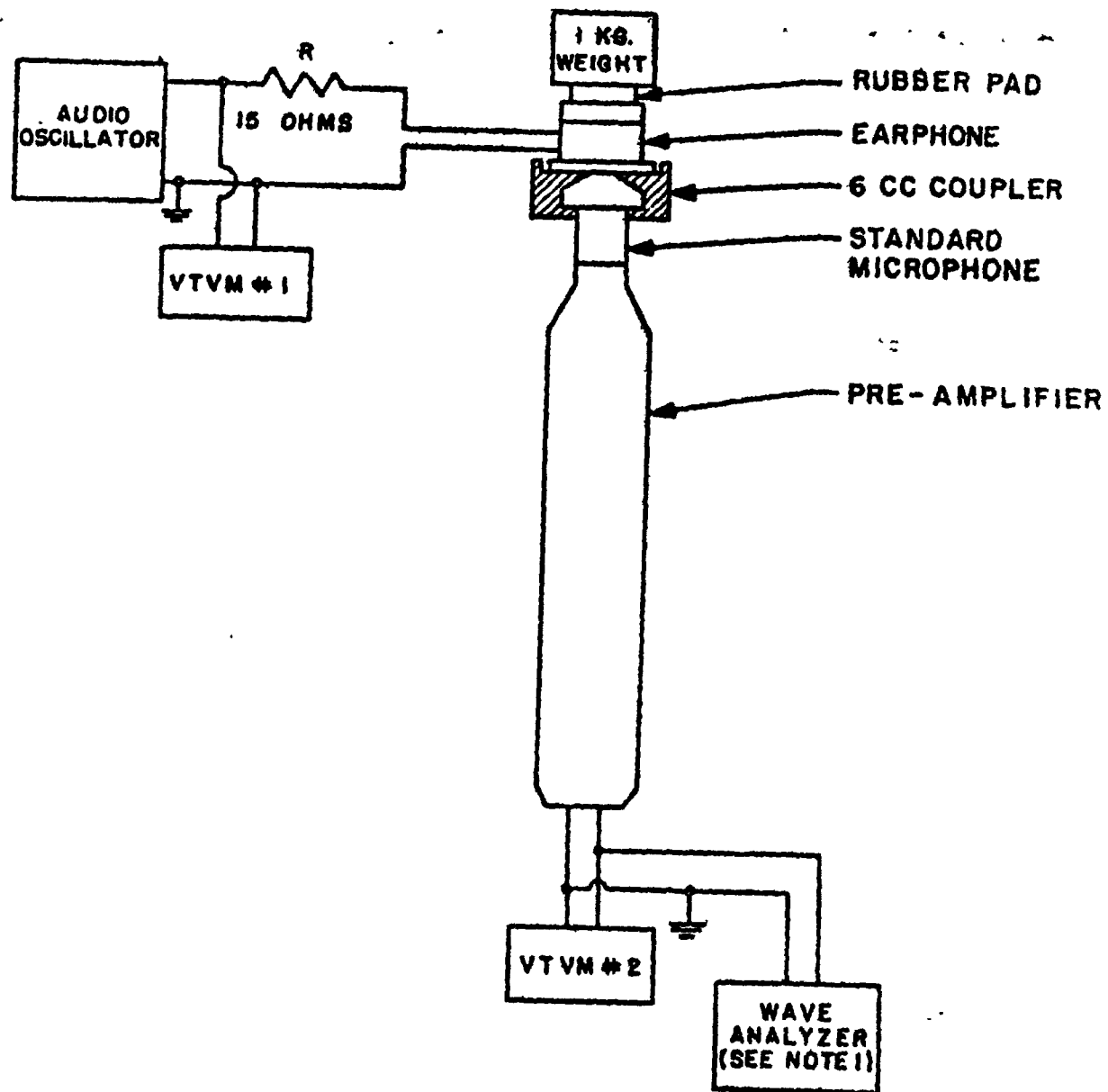

NOTE 1: WAVE ANALYZER REQUIRED FOR DISTORTION TEST ONLY

FIGURE 4 Earphone frequency response test circuit.

MIL-E-55119A(EL)

4.8.5 Dielectric strength and insulation resistance test. The earphone shall be tested for compliance with 3.7.4

4.9 Operational test. Prior to packaging, completely assembled headsets shall be tested by a talk test to insure correct wiring and satisfactory operation.

4.10 Visual and mechanical inspection. The equipment shall be examined for the defects listed in Standard MIL-STD-252.

4.11 Inspection for dimensional interchangeability. Each replaceable part listed below in the selected Transducer Equipments shall be interchanged with the corresponding part in the approved preproduction sample in sequential order. At the completion of this inspection, the interchanged parts shall be reassembled in their original transducer equipments. Noninterchangeability of these parts constitute failure.

Switches

Boots

Retainer plates

Cable relief spring, retaining bushing,
and cord

Microphone mounting clip

Mounting screws

Ear cushions

Boom

Headband

4.12 Life test switch.

4.12.1 Push-a-talk switch (H-138()/GR, M-80()/GR, M-81()/GR). The switch shall be tested by operating it for 500,000 "make" and "break" cycles, with positive detent action, at a rate not to exceed 1 cycle per second at a rated load of one-half ampere and 24 volts flowing through the control circuit in series with a resistive load (see 3.9.1)

4.12.2 Toggle switch (H-139()/GR, H-140()/GR, H-141()/GR, H-161()/GR). The switch shall be tested to determine compliance with 3.9.2. A series circuit shall be set up including a 24 volt dc supply, a resistive load, and the switch. During the test, 250 milliamperes shall flow in the control circuit, and no current shall flow in the microphone circuit of the switch.

One cycle of switch operation test shall consist of the following, in sequence:

- (a) Switch in mid-position.
- (b) Switch in forward position.
- (c) Switch in mid-position
- (d) Switch in back position.
- (e) Switch in mid-position.

Each cycle of switch operation shall take approximately 2 seconds. The switch shall be tested for 100,000 cycles operation.

4.12.3 Lever switch (MK-525()/G and MK-526()/G) The switch shall be tested to determine compliance with 3.9.3. A series circuit shall be set up including a 24 volt dc supply, a resistive load, and the switch. During the test, one ampere shall flow in the control circuit, and 60 milliamperes shall flow in the microphone circuit of the switch. One cycle of switch operation test shall consist of the following, in sequence:

- (a) Switch in mid-position.
- (b) Switch in forward position.
- (c) Switch in mid-position
- (d) Switch in back position
- (e) Switch in mid-position.

4.13 Service conditions tests.

4.13.1 Temperature test. The equipment shall be subjected to the temperature cycle shown on Standard MIL-STD-169. The test of 4.9 shall be performed at step 3 and step 8. At step 10, the equipment shall meet the requirements of 3.6.1 and 3.7.1 with degradation not to exceed 3 db

4.13.2 Moisture resistance

4.13.2.1 Test conditions

- (a) Do not remove equipment from the humidity chamber for measurements
- (b) Start measurements not more than 5 minutes after power is applied to the equipment. Complete measurements as rapidly as possible. Do not leave power on after measurements have been completed.

4.13.2.2 Test procedure The equipment shall be tested as follows:

- (a) Dry at 130° ±5°F. for 24 hours.

MIL-E-55119A(EL)

- (b) Condition at $77^{\circ} \pm 5^{\circ}\text{F}$. and 40 to 50 percent relative humidity for 24 hours
- (c) Perform the test of 4.9.
- (d) Subject to continuous cycling for five 48 hour cycles. Temperature, relative humidity, and period of time for each portion of the cycle shall conform to MIL-STD-170. Perform the test of 4.9 at the times specified on the standard
- (e) After cycling has been completed, condition the equipment for 24 hours at $77^{\circ} \pm 5^{\circ}\text{F}$ at 40 to 60 percent relative humidity. The equipment shall meet the requirements of 3.6.1 and 3.7.1 with degradation not to exceed 3 db. There shall be no evidence of cracking, warping, or other mechanical deterioration

4.13.3 Altitude test

4.13.3.1 Operating The microphone and earphone units shall be placed in an altitude chamber. The response of the microphone and earphone units at ground level shall be obtained at 300, 600, 1000, 2000, and 3500 cps. Pressure inside the chamber shall then be reduced to that corresponding to an altitude of 15,00 feet. The response of the microphone and earphone units shall be taken again at the same frequencies as mentioned above. The degradation in response of either unit shall be not more than 5 db from the requirements of 3.6.1 and 3.7.1.

4.13.3.2 Nonoperating The microphone and earphone shall be subjected to 5 varying pressure cycles. Each pressure cycle shall consist of 30 minutes at 3.4 inches of mercury. The pressure transition shall be approximately 5000 feet per minute. The response characteristics of the earphone and microphone shall be measured, and shall not exhibit a degradation in performance in excess of 5 db from the requirements of 3.6.1 and 3.7.1 after being subject to five pressure cycles

4.13.4 Immersion The equipment shall be immersed to a depth of 3 feet of fresh water at room temperature for 2 hours. After completion of the 2 hour period of immersion, evidence of

water in the switch cavity shall be cause for rejection. Remove any water from the earphone and microphone cavities. The microphone and earphone shall then meet the requirements of 3.6.1 and 3.7.1 respectively.

4.13.5 Salt spray test. The completely assembled equipment shall be exposed to salt spray in accordance with Method 101 of MIL-STD-202 for 48 hours. Upon completion of the test, there shall be no evidence of harmful corrosive action or damage due to the salt spray. The earphone and microphone shall not suffer a degradation in response in excess of 3 db from their performance values of 3.6.1 and 3.7.1.

4.13.6 Blast test. Each earphone and microphone element being tested shall be mounted on the carriage of the U. S. Navy Simulated Gun Blast Equipment in accordance with Bureau of Ships Drawing SK-N-864 with the front edge of the earphone or microphone element in the test plane, and with its axis coincident with that of the explosion chamber. The earphone and microphone element shall be subjected to 30 rounds of blast at a peak pressure of 9.5 pounds per square inch. The earphone and microphone units shall not suffer a degradation in their response of more than 3 db from the performance values of 3.6.1 and 3.7.1.

4.13.7 Vibration test The complete equipment shall be subjected to the vibration test in accordance with Method 201 of MIL-STD-202. The equipment shall be mounted in a horizontal position, and shall be vibrated in a direction perpendicular to the plane of the earphone and microphone for a period of 5 hours. Tests of the earphone element and the microphone element shall be made to determine compliance with 3.6.1 and 3.7.1, respectively prior to, and after the cycling. Upon completion of the vibration test, the equipment shall exhibit no evidence of loosening of parts or other mechanical damage and shall meet full specification requirements.

4.13.8 Bounce test. The equipment shall be tested on the package tester, as made by the L.A.B. Corporation, Skaneateles, N.Y., or equal, as follows:

- (a) Cover the tester bed with a panel of $\frac{1}{2}$ -inch plywod, with the grain parallel

MIL-E-55119A(EL)

to the drive chain. Space sixpenny nails, with the heads below the surface, at 6-inch intervals around all four edges and at 3-inch intervals in a 6-inch square in the center

- (b) Place the equipment on the bed of the package tester. Limit the lateral motion, by wooden fences, to not more than 3 inches and not less than 1 inch. Additional barriers may be used to prevent tumbling, provided that the fore-and-aft motion of the equipment against the back stop is not restrained
- (c) Operate the package tester, shafts in phase, for a total of 3 hours at 284 \pm 2 rpm. Turn the equipment at the end of each 30 minutes so it will rest on a new face,
- (d) At the conclusion of the test, the equipment shall meet the requirements of 3.6.1 and 3.7.1 with degradation not to exceed 3 db.

4.13.9 Shock drop test The complete assembled equipment shall be dropped twelve times at random from a height of 6 feet onto concrete. The equipment shall operate satisfactorily after being dropped and shall not suffer any degradation in performance of more than 3 db for the microphone element or for the earphone when tested in accordance with 3.6.1 and 3.7.1 respectively. The handle shall show no evidence of breaking or cracking or damage to switch. Minor chipping shall not be considered a failure

4.14 Quality conformance inspection of preparation for delivery. Preparation for delivery shall be inspected in accordance with Specification MIL-P-116 to determine conformance to the requirements of section 5

5. PREPARATION FOR DELIVERY

5.1 Preservation and packaging.

5.1.1 Level A The Electro-Acoustical Transducer Equipments shall be preserved, packaged and tested in accordance with the applicable provisions of Specification MIL-P-116 and in a manner that will afford adequate protection against corrosion, deterioration and damage dur-

ing worldwide shipment, handling and open storage.

5.1.2 Level C. The Electro-Acoustical Transducer Equipments shall be afforded preservation and packaging in accordance with the suppliers' normal commercial practice.

5.2 Packing. The Electro-Acoustical Transducer Equipments packaged as specified, shall be packed in shipping containers conforming to the requirements of the specifications referenced below for the designated level. The gross weight shall not exceed the weight shown unless an individually packed item exceeds that amount. Closure and strapping shall be as prescribed in the applicable box specification or appendix thereto, except that bands of reinforced, pressure-sensitive adhesive tape, 1/2 inch wide and conforming to Specification PPP-T-97 for grade IV, shall be used for fiberboard boxes in lieu of metal strapping.

5.2.1 Level A

	<i>Box specification</i>	<i>Max gross wt</i>
Fiberboard (Type 1, Class 2)	PPP-B-636	Table VI
Nailed Wood (Style 4, Class 2)	PPP-B-621	200 lbs
Wirebound (Style 2 or 3, Class 2)	PPP-B-585	200 lbs
Wood Cleated Fiberboard (Overseas)	PPP-B-591	200 lbs
Wood Cleated Plywood (Overseas)	PPP-B-601	200 lbs
Wood Cleated, Veneer, Paper Overlaid (Overseas)	MIL-B-10377	200 lbs

5.2.2 Level B

	<i>Box specification</i>	<i>Max gross wt</i>
Fiberboard (Type 1, Class 1)	PPP-B-636	Table I
Nailed Wood (Style 4, Class 1)	PPP-B-621	200 lbs.
Wirebound (Style 3, Class 1)	PPP-B-585	200 lbs
Wood Cleated Fiberboard (Domestic)	PPP-B-591	200 lbs
Wood Cleated Plywood (Domestic)	PPP-B-601	200 lbs.
Wood Cleated, Veneer, Paper Overlaid (Overseas)	MIL-B-10377	200 lbs

5.2.3 Level C. The Electro-Acoustical Transducer Equipments shall be packed in shipping

MIL-E-55119A(EL)

containers of the type, size and kind commonly used for the purpose in a manner that will insure acceptance by common carrier and safe delivery at destination. Shipping containers shall comply with the rules or regulations of the common carrier, applicable to the mode of transportation.

5.2.4 Pilot Pack. When Level "A" packaging and packing is specified above, one acceptable model of the equipment will be pilot packed in a manner that will pass the preproduction tests prescribed in Specification MIL-P-116. Illustrations of the packaging and packing procedure, together with Bills of Material, will be prepared and furnished in accordance with the provisions of Signal Corps Drawing Number SC-A-362100.

5.3 Marking. In addition to any special marking required by the contract or order, interior packages and exterior shipping containers shall be marked in accordance with the applicable provision of Standard MIL-STD-129.

6. NOTES

6.1 Intended use. The equipment covered in this specification is intended for use as audio accessories for Radio Set AN/VRC-12.

6.2 Ordering data. Procurement documents should specify the following:

- (a) Title number, and date of this specification and any amendment thereto.
- (b) Type required.
- (c) Level of packaging and level of packing required for shipment. (Level A, level B, or Level C.)

(d) The specific paragraphs of section 5 which are applicable to the particular procurement.

(e) Preproduction pack(s) as follows:

Makeup of pack(s).

Number of each kind of pack to be submitted.

Inspection to be performed thereon.

(f) Marking and shipping of samples.

(g) Place of final inspection.

6.3 Nomenclature. The parentheses in the nomenclature will be deleted or replaced by a letter identifying the particular design; for example: H-139W/GR. The contractor should apply for nomenclature in accordance with the applicable clause in the contract (see 1.1).

6.4 Group C inspection. Approval to ship may be withheld, at the discretion of the Government pending the decision from the contracting officer on the adequacy of corrective section.

6.5 Verification inspection. Verification by the Government will be limited to the amount deemed necessary to determine compliance with the contract and will be limited in severity to the definitive quality assurance provisions established in this specification and the contract. The amount of verification inspection by the Government will be adjusted to make maximum utilization of the contractor's quality control system and the quality history of the product.

Custodian:

Army—EL

Preparing activity:

Army—EL

Project No. 5965-A027

MIL-E-55119A(EL)

SPECIFICATION ANALYSIS SHEET		Form Approved Budget Bureau No 119-R004
INSTRUCTIONS		
This sheet is to be filled out by personnel either Government or contractor, involved in the use of the specification in procurement of products for ultimate use by the Department of Defense. This sheet is provided for obtaining information on the use of this specification which will insure that suitable products can be procured with a minimum amount of delay and at the least cost. Comments and the return of this form will be appreciated. Fold on lines on reverse side, staple in corner, and send to preparing activity.		
SPECIFICATION		
ORGANIZATION		CITY AND STATE
CONTRACT NO	QUANTITY OF ITEMS PROCURED	DOLLAR AMOUNT \$
MATERIAL PROCURED UNDER A		
<input type="checkbox"/> DIRECT GOVERNMENT CONTRACT <input type="checkbox"/> SUBCONTRACT		
1 HAS ANY PART OF THE SPECIFICATION CREATED PROBLEMS OR REQUIRED INTERPRETATION IN PROCUREMENT USE? A GIVE PARAGRAPH NUMBER AND WORDING		
B RECOMMENDATIONS FOR CORRECTING THE DEFICIENCIES		
2 COMMENTS ON ANY SPECIFICATION REQUIREMENT CONSIDERED TOO RIGID		
3 IS THE SPECIFICATION RESTRICTIVE? <input type="checkbox"/> YES <input type="checkbox"/> NO IF "YES" IN WHAT WAY?		
4 REMARKS (Attach any pertinent data which may be of use in improving this specification. If there are additional papers, attach to form and place both in an envelope addressed to preparing activity)		
SUBMITTED BY (Printed or typed name and activity)		DATE

To detach this form, cut along this line

DD FORM 1426
1 APR 63

20