

INCH POUND

MIL-DTL-9479E
w/AMENDMENT 1
16 November 2007
SUPERSEDING
MIL-DTL-9479E (USAF)
17 September 1999

DETAIL SPECIFICATION

SEAT SYSTEM, UPWARD EJECTION, AIRCRAFT,

GENERAL SPECIFICATION FOR

This document remains inactive for new design

This specification is approved for use by the Department of the Air Force and is available for use by all Departments and Agencies of the Department of Defense

1. SCOPE

1.1 Scope.

This specification covers the general requirements for adjustable, upward, aircraft ejection seat systems.

2. APPLICABLE DOCUMENTS

2.1 General.

The documents listed in this section are specified in sections 3 and 4 of this specification. This section does not include documents cited in other sections of this specification or recommended for additional information or as examples. While every effort has been made to ensure the completeness of this list, document users are cautioned that they must meet all specified requirements documents cited in sections 3 and 4 of this specification, whether or not they are listed.

Comments, suggestions, or questions on this document should be addressed to ASC/ENOI, 2530 Loop Road West, Wright-Patterson AFB OH 45433-7101 or emailed to EngineeringStandards@wpafb.af.mil. Since contact information can change, you may want to verify the currency of this address information using the ASSIST Online database at <http://assist.daps.dla.mil>.

AMSC/NA

FSC 1680

DISTRIBUTION STATEMENT A. Approved for public release; distribution is unlimited.

**MIL-DTL-9479E
w/Amendment 1**

2.2 Government documents.

2.2.1 Specifications and standards.

The following specifications and standards form a part of this document to the extent specified herein. Unless otherwise specified, the issues of these documents are those listed in the issue of the Department of Defense Index of Specifications and Standards (DoDISS) and supplement thereto, cited in the solicitation (see 6.2).

DEPARTMENT OF DEFENSE SPECIFICATIONS

MIL-R-8236	Reel, Shoulder Harness, Inertia Lock
MIL-H-25579	Hose Assembly, Tetrafluoroethylene, High Temperature Medium Pressure, General Requirements for
MIL-C-83124	Cartridge Actuated Devices/Propellant Actuated Devices, General Design Specification for
MIL-C-83125	Cartridge for Cartridge Actuated/Propellant Actuated Devices, General Design Specification for
MIL-S-83427	Survival Kit Containers, CNU-129(V)/P and CNU-130/P

FEDERAL STANDARDS

FED-STD-191	Textile Test Methods
FED-STD-595	Colors Used in Government Procurement

DEPARTMENT OF DEFENSE STANDARDS

MIL-STD-130 Identification Marking of U. S. Military Property

(Unless otherwise indicated, copies of the above specifications, standards, and handbooks are available from <http://assist.daps.dla.mil> or from the Standardization Documents Order Desk, 700 Robbins Ave, Building 4D, Philadelphia, Pennsylvania 19111-5094.)

2.2.2 Other Government documents, drawings, and publications.

The following other Government documents, drawings, and publications form a part of this document to the extent specified herein. Unless otherwise specified, the issues are those cited in the solicitation.

AIR FORCE

67D34391 Streamer Assembly - Warning, Flight Status

(Application for copies should be addressed to the SA-ALC/TILDD, 306 Tinker Drive, Bldg. 207, Kelly AFB, Texas 78241-5000.)

**MIL-DTL-9479E
w/Amendment 1**

2.3 Non-Government publications.

The following documents form a part of this document to the extent specified herein. Unless otherwise specified, the issues of the documents which are DoD adopted are those listed in the issue of the DoDISS cited in the solicitation. Unless otherwise specified, the issues of documents not listed in the DoDISS are the issues of the documents cited in the solicitation (see 6.2).

RADIO TECHNICAL COMMISSION FOR AERONAUTICS (RTCA)

DO-160C Environmental Test Methods (RTCA/FAA)

(Application for copies should be addressed to the Radio Technical Commission for Aeronautics, One McPherson Square 1425 K Street, N.W., Suite 500, Washington, D.C. 20005)

SOCIETY OF AUTOMOTIVE ENGINEERS (SAE)

SAE AMS 2470 Anodic Treatments of Aluminum Alloys, Chromic Acid Process (DOD Adopted)

SAE AMS 2475 Protective Treatments, Magnesium Alloys (DOD Adopted) SAE AMS 2759 Heat Treatment of Steel Parts, General Requirements (DOD Adopted)

SAE-AMS-STD-2175 Castings, Classification and Inspection of

(Application for copies should be addressed to the Society of Automotive Engineers, 400 Commonwealth Dr., Warrendale, Pennsylvania 15096-0001)

AMERICAN SOCIETY FOR TESTING AND MATERIALS (ASTM)

ASTM B633 Zinc on Iron and Steel, Electrodeposited, Coatings of (DOD Adopted)

ASTM B597 Heat Treatment of Aluminum Alloys (DOD Adopted)

(Application for copies should be addressed to the American Society for Testing and Materials, 1916 Race Street, Philadelphia Pennsylvania 19103.)

2.4 Order of precedence.

In the event of a conflict between the text of this document and the references cited herein (except for related associated specifications or specification sheets), the text of this document takes precedence. Nothing in this document, however, supersedes applicable laws and regulations unless a specific exemption has been obtained.

**MIL-DTL-9479E
w/Amendment 1**

3. REQUIREMENTS

3.1 First article.

When specified (see 6.2), a sample shall be subjected to first article inspection in accordance with 4.4.

3.2 Design.

3.2.1 Seat assembly.

The seat assembly shall provide adequate support and retention of the occupant's head, neck body, arms, and legs during emergency operation; shall be fully suited to normal operational use; and shall comfortably accommodate variations in anthropometric dimensions for the central 90% of crew member sizes represented by multivariate anthropometric cases (see 6.5).

3.2.1.1 Vertical adjustment.

The seat assembly shall be provided with a 5 inch vertical adjustment. The seat adjustment shall be accomplished by powered movement of the entire ejectable portion of the seat system, including the rocket catapult as a single unit (see 4.5.2).

3.2.1.2 Vertical adjustment control.

The vertical adjustment control shall be located on the right-hand side of the seat bucket and shall be easily accessible to the seat occupant. A momentary-ON three-position center-OFF type switch shall be used. The switch shall be positioned so that the direction of switch actuation corresponds with the direction of seat movement (see 4.5.2).

3.2.2 Ejection position.

The ejection seat system shall be designed to permit ejection from any position within the range of vertical seat adjustment (see 4.4.1 a, 4.5.1).

3.2.3 Seat bucket sides.

In order to provide lateral leg retention, the seat bucket sides shall extend forward of the front edge of the seat bottom. The seat side extensions shall be designed to laterally brace the seat occupant's legs against airloads encountered subsequent to ejection (see 4.4.1 a, 4.5.1).

3.2.4 Headrest.

A headrest shall be provided in the upper portion of the seat back and located to provide head support for all sizes of crew members. The headrest design shall include a fixed dimensional relationship with the seat bottom for all conditions of seat adjustment and shall incorporate provisions to diminish lateral head motion under ejection conditions. The entire upper portion of the seat back shall be designed to permit maximum rearward vision consistent with structural requirements for head support and operational requirements when installed in the aircraft. The headrest shall not cause any interference with seat-man separation (see 4.4.1 a, 4.5.1).

**MIL-DTL-9479E
w/Amendment 1****3.2.4.1 Headrest material.**

The contact surface of the headrest shall be padded with a high energy-absorbing foam material with a thickness of 1.75 inches and a density of 2 pounds per cubic foot. This foam shall be covered with a padding of 2 pounds per cubic foot flexible foam, 0.19-inches thick (see 4.4.1 a, 4.5.1).

3.2.5 Canopy piercers.

Canopy piercers shall be incorporated in the seat assembly except where ejection through the canopy is not permitted because of hatch or canopy construction. The design and installation of the canopy piercers shall ensure positive canopy penetration before contact can occur between the canopy and seat occupant and shall also ensure a clear opening through the canopy sufficient for safe passage of the seat and seat occupant (see 4.4.1 a, 4.5.1).

3.2.6 Armrests.

Armrests may be mounted on the seat bucket sides. The armrests shall be designed to provide lateral arm restraint during emergency operation, shall comfortably accommodate all crew members with their flight clothing and shall not interfere with crew member access to the aircraft flight controls. The contact surfaces of the armrests shall be padded with a high-energy-absorbing material of at least 1/2-inch thickness (see 4.4.1 a, 4.5.1).

3.2.7 Environmental flight clothing.

The seat assembly shall be designed to provide space for and be compatible with crew members wearing any of the environmental flight clothing and personal equipment required for the aircraft (see 4.4.1 a, 4.5.1).

3.2.8 Emergency oxygen.

An emergency source of oxygen shall be mounted on the seat assembly to provide emergency breathing oxygen, and, if required, pressure suit pressurization. The source shall contain sufficient oxygen for an emergency descent in the aircraft from maximum altitude, or for free fall following ejection from maximum altitude to the pressure altitude setting of the recovery parachute. Provisions shall be incorporated for actuation of the oxygen supply manually in the aircraft and automatically upon ejection. The emergency oxygen supply shall be replaceable without removing the seat from the crew station and shall include a readily visible status indicator to reflect full oxygen supply (see 4.4.1 a., 4.5.1).

3.2.9 Personal lead services.

Personal leads shall be provided for the following services as required: aircraft oxygen, emergency oxygen, communications, anti-g, and ventilation. Personal leads shall be standard according to the service provided. Personal lead connections shall be positive to ensure the proper attachment is obtained to provide the required service. All disconnections shall be accomplished automatically during the ejection-recovery sequence, as necessary for the required services. Provisions shall be incorporated for disconnection of personal leads in conjunction with the automatic and manual release functions of the personal restraint subsystem (see 4.4.1 a, 4.5.1).

**MIL-DTL-9479E
w/Amendment 1**

3.2.10 Ejection rails.

A set of ejection rails and rollers (or slide blocks) shall be furnished with the seat assembly. The rails shall be designed to be installed parallel to the seat back and shall be sufficiently rigid to prevent deflection which would cause binding of the rollers (or slide blocks) or allow the rollers to jump the rails. The rails and rollers (or slide blocks) shall be designed to provide maximum guided catapult stroke in the aircraft during ejection. The ejection rails and rollers (or slide blocks) shall be such that the friction produced between the rails and rollers (or slide blocks), as a result of the airload on the seat during ejection, will be held to a minimum. Provisions shall be made to prevent foreign objects from becoming lodged between the rollers (or slide blocks) and the rails, consistent with ease of seat installation. The rails and rollers (or slide blocks) shall retain the seat and crewman combination under all ditching and crash loads (see 4.4.1 a, 4.5.1).

3.2.11 Personal restraint subsystem.

The seat system shall incorporate a personal restraint subsystem that will provide full upper and lower torso restraint and control, and shall not decrease crew member efficiency nor cause more than a minimum of restriction to movement during normal flight. The restraint attachments shall be designed to provide sufficient structural integrity for positive crew member protection without injury under all conditions of emergency ejection, ditching, and crash impact. Torso restraint shall be provided through use of an integrated torso harness. The torso harness shall include provisions for attaching personal parachute risers and the survival kit. Depending upon system design, it may also contain provisions for attaching lap straps from the seat in lieu of using a separate lap belt assembly. In cases where lap straps are used, the attachment to the torso harness shall be designed to prevent any movement or submarining of the seat occupant because of ejection, ditching, or crash accelerations (see 4.5.1, 4.5.6.11).

3.2.11.1 Upper torso restraint.

The seat system shall incorporate an inertia reel mechanism conforming to MIL-R-8236, with additional requirements for powered retraction. The manual inertia lock reel control shall be located on the left side of the seat assembly with easy access by the seat occupant. The inertia reel mechanism shall include powered retraction provisions to automatically position and restrain the seat occupant against the backrest of the seat as a pre-ejection function. The powered retraction provisions shall be capable of positioning the seat occupant through 0 to 18 inches of travel and taking a load up to 300 pounds within 0.3 seconds maximum at 70°F (0.4 seconds maximum at -65°F). The reel-in velocity shall be limited to a mean of 9 feet per second with a standard deviation of 1 foot per second. The maximum total load applied to the seat occupant after the reel has positioned the occupant shall not exceed 100 pounds (see 4.5.1, 4.5.6.11).

3.2.11.2 Inertia reel strap bearing point.

The inertia reel strap shall be located so that, when in the fully restrained position, no compression loads will be transferred to the seat occupant's spinal column. This shall be based upon a 95th-percentile sitting shoulder height (see 4.5.1, 4.5.6.11).

3.2.11.3 Lower torso restraint.

The seat system shall incorporate provisions for lower torso restraint through the use of either a lap belt assembly or lap straps that attach from the seat assembly to the torso harness. In either case, the seat attachment points shall be located on a line in the side view which is 45° to the seat bucket bottom and through the seat reference point (this line is shown in figure 1 labeled as

**MIL-DTL-9479E
w/Amendment 1**

the "Lap Strap Attachment Line"). In systems designed to incorporate lap straps, the survival kit retention straps shall be permanently attached to the lap straps so that the survival kit actuator handle is clear for easy access by the crew member at all times during parachute descent prior to kit actuation (see 4.5.1, 4.5.6.11).

3.2.11.4 Automatic restraint subsystem release.

Provisions shall be incorporated to automatically release the crew member from the seat system after ejection. Sequencing of the automatic release shall be compatible with the recovery parachute operation (see 4.5.1, 4.5.6.11).

3.2.11.5 Manual restraint subsystem release.

Manual restraint subsystem releases shall be provided which incorporate the following features (see 4.5.1):

- a. Ability to release the crew member from the seat system (including parachute and survival equipment) when the seat system is in the aircraft cockpit.
- b. Ability to release the crew member, and deploy the recovery parachute and survival equipment from the seat assembly after ejection from the aircraft.
- c. Actuation of the control with a squeeze to release the safety latch and a single motion to initiate the subsystem.
- d. Release control designed and located so that it can be easily reached and actuated by a crew member with the control in the fully retracted position, including actuation by a pressurized pressure suit gloved hand, if applicable.
- e. The release control shall include a lock mechanism which requires a separate reset function after the control has been actuated. The reset function shall not require the use of tools.

3.2.12 Ingress and egress devices.

Any fastening devices provided on the restraint subsystem for normal ingress to, or egress from the seat system, shall be easy to operate, for example, single movement, single handled, or without requiring multiple actions. The number of such devices shall be kept to a minimum and shall be designed so that they can be attached and detached by the crew member without assistance (see 4.5.1, 4.5.6.11).

3.2.13 Initiation subsystem.

All pre-ejection functions and firing of the seat system rocket catapult shall be accomplished by one complete extension of the ejection controls. Unless otherwise specified, controls shall be integrated into loop-type hand grips on the forward portions of both sides of the seat bucket. The complete ejection sequence shall be initiated by a single, upward-and-aft movement of either hand grip. The motion of the ejection controls shall be irreversible, and the controls shall be interconnected to provide initiation of ejection when either or both of the controls are actuated. This subsystem shall be equipped with a safety lock integrated into the controls, which must be released before actuation can be accomplished. The safety lock shall be designed to permit arming and safing the ejection control by a seated crew member (see 4.5.1, 4.5.8).

**MIL-DTL-9479E
w/Amendment 1**

3.2.13.1 Pre-ejection functions.

The following are required pre-ejection functions that will occur after activation of an ejection control (see 4.5.1, 4.5.8):

- a. Initiation of crew member positioning and restraint.
- b. Initiation of canopy and hatch removal.
- c. Initiation of ejection sequencing subsystem where applicable (see 3.2.13.6).

3.2.13.2 Control forces.

The force required to actuate each ejection control hand grip shall be 20 ± 3 pounds, unless otherwise specified (see 4.5.1).

3.2.13.3 Ground safety device.

The seat system shall be protected against inadvertent actuation on the ground by a single safety device. The safety device shall positively lock all controls in the stowed position. The linkage between ejection controls and system initiators shall be designed so that when the controls are safetied, application of force to the linkage will not actuate the system. Additional ground safety devices shall be provided for protection during maintenance activities, but they shall be interconnected and located so they cannot remain installed when the aircraft is ready for flight. Streamers on the safety devices shall be provided in accordance with drawing 67D34391 (see 4.5.1).

3.2.13.4 Canopy and hatch removal.

The seat system shall include provisions for positive, immediate removal of the aircraft canopy and hatch (see 4.5.1).

3.2.13.5 Ejection through the canopy.

The ejection controls and initiation subsystem shall be designed to permit automatic ejection of the seat assembly through the canopy in the event the canopy jettison mechanism malfunctions. On those aircraft where ejection through the canopy is not permitted because of hatch or canopy construction, means shall be provided to prevent firing of the rocket catapult until the hatch or canopy has been jettisoned (see 4.5.1, 4.5.7).

3.2.13.6 Ejection sequencing subsystem.

For a multi-crew aircraft requiring an ejection seat system, an ejection sequencing subsystem shall be provided. The sequencing subsystem shall be initiated by the command pilot as a pre-ejection function but shall not prevent the other crew member(s) from initiating their own ejection. The sequencing subsystem shall be designed to jettison canopies and eject the seat-man combinations in a manner to (see 4.4.2 c., 4.5.5):

- a. Provide protection for personnel from the rocket-catapult heat and blast effects.
- b. Ensure the escape of all crew members in minimum time (see 6.2).
- c. Preclude collisions between jettisoned canopies and ejected seat-man combinations.
- d. Preclude collisions between ejected seat-man combinations.

MIL-DTL-9479E
w/Amendment 1

In training aircraft, the sequencing subsystem shall provide a means for the instructor pilot to initiate the ejection for both crewmen from either ejection seat position. Particular attention shall be directed toward ensuring minimum time between ejection initiation and separation of the last crew member from the aircraft.

3.2.14 Actuation subsystem.

All propellant-actuated devices and cartridge-actuated devices shall conform to MIL-C-83125 and shall be approved by the procuring activity prior to installation. The energy required for activation of mechanical or propulsion links may be transmitted either by transmission hose, detonating transmission lines, electrical lines, or fiber-optic cable. Ballistic gas transmission hose shall conform to the -4 configuration of MIL-H-25579. The ballistic gas transmission hose and fittings shall provide free flow in accordance with the design schematic of the ballistic subsystem (see 4.4.1 b., 4.5.3).

3.2.15 Propulsion subsystem.

The seat system shall be provided with a propulsion subsystem with sufficient impulse to ensure aircraft tail clearance throughout the aircraft performance envelope and, in conjunction with the parachute recovery system, provide recovery from high sink-rate conditions. If a rocket catapult subsystem is used, it shall conform to MIL-C-83124 and shall be approved by the procuring activity prior to installation. The catapult action shall be aligned within 5° of the seat assembly back angle. The thrust shall be as defined by the center-of gravity (cg) envelope (4.5.8).

3.2.16 Precautions against improper component installation.

Cartridge-actuated devices, propellant-actuated devices, and other replaceable components shall be designed to preclude improper installation which could adversely affect the proper functioning of the seat system or its subsystems (see 4.5.2).

3.2.17 Stabilization subsystem.

Provisions shall be incorporated for seat-man stability during free flight, including the period from rocket ignition through recovery parachute deployment. The stabilization subsystem shall become effective at the time of seat-aircraft separation and shall include the following characteristics (see 4.5.8):

- a. Counteract rotations caused by the eccentricity between the dynamic cg and the rocket thrust line, and by aerodynamic forces.
- b. Control the application of deceleration forces. The ejection seat shall be stabilized in such a manner that the neutral direction of aerodynamic deceleration is eyeballs out or eyeballs in. Damped oscillations about the neutral direction of aerodynamic deceleration shall not exceed 20° in the pitch or yaw plane.
- c. Maintain optimum attitude for recovery parachute deployment.
- d. Stabilize the seat-man combination during free fall to the pressure altitude setting for recovery parachute opening, following a high altitude ejection.

**MIL-DTL-9479E
w/Amendment 1****3.2.17.1 CG envelope.**

The cg envelope applicable to the stabilization subsystem for the seat system shall be the broadest envelope determined by surveying crew member body sizes and authorized equipment combinations. Based upon the static cg locations for the full range of crew members, the cg envelope shall include a +2.0 inch tolerance about each individual cg with respect to the rocket thrust line. The relationship of rocket thrust line to cg envelope shall be in accordance with the principle shown on figure 2; however, the cg envelope may not necessarily be completely above the thrust line (see 4.5.8).

3.2.18 Parachute recovery subsystem.

The parachute recovery subsystem shall incorporate an Air Force approved and qualified canopy and shall be fully automatic upon ejection control actuation. The initiation of the recovery parachute shall be controlled by a multimode velocity, acceleration, or force-sensing device and an aneroid. The pressure altitude of the recovery subsystem shall be 15,000 + 1,000 feet. At altitudes below this setting, the recovery parachute shall be deployed in the minimum time after ejection, consistent with human tolerances. The parachute shall be released from the crew member by the actuation of not more than two releases (see 4.5.8).

3.2.18.1 Manual parachute deployment.

Provision shall be incorporated for manual parachute deployment following ejection. An actuation handle for manual deployment shall be provided which can be easily reached and actuated by the crew member. The control shall be actuated by a force not greater than 27 pounds, using only one hand (see 4.5.1, 4.5.8).

3.2.18.2 Seat-man separation.

Seat-man separation shall be accomplished by the deployment and inflation of the recovery parachute. This separation shall be positive and shall prevent seat interference with the man or parachute (see 4.5.1, 4.5.8).

3.2.19 Survival subsystem.

A survival kit in accordance with MIL-S-83427 shall be provided in the seat bucket, except that oxygen equipment and provisions shall not be included within the kit. The kit shall be restrained during negative g maneuvers. The system shall allow a seated crewman to select manual or automatic deployment of the survival kit. The kit shall be attached to the personal restraint subsystem and, when selected, shall be automatically deployed in conjunction with the parachute recovery subsystem operation (see 4.5.1).

3.2.19.1 Personal locator devices.

A method shall be incorporated for automatically actuating personal locator devices upon seat ejection. Any personal locator device antenna shall be routed to afford maximum signal capability. The automatic actuation feature shall include a rapid disarming capability which will permit the crew member to disarm the locator device while in the seat (see 4.5.1).

**MIL-DTL-9479E
w/Amendment 1**

3.3 Fit.

3.3.1 Dimensions.

The seat system shall be compatible and integrate with the aircraft for which it is manufactured (see 6.7). The dimensions of the seat system shall be as specified in figures 1 and 3 (see 4.5.2).

3.3.2 Weight.

The weight of the seat system shall be kept to a minimum consistent with the escape requirements and the performance of the aircraft (see 4.5.2).

3.3.3 Interchangeability.

All parts having the same manufacturer's part number shall be directly and completely interchangeable with each other with respect to installation and performance. Changes in manufacturer's part numbers shall be documented by the contractor and provided to the government when configuration control is transferred (see 4.5.2).

3.4 Function.

3.4.1 Windblast.

Unless otherwise specified, the ejection seat shall be designed to prevent the following windblast effects resulting from the maximum aircraft airspeed or 600 knots equivalent airspeed (KEAS), whichever is less (see 4.5.6.11):

- a. Disconnected personal leads.
- b. Distorted personal leads.
- c. Flailing of personal leads, equipment, or crewmember arms and legs.
- d. Personnel restraint subsystem failure.
- e. Separation or damage of seat components.

3.4.2 System operation time.

The total time from ejection sequence initiation to full inflation of the recovery parachute shall not exceed 3 seconds at any altitude below the pressure altitude setting of the recovery parachute (see 4.5.8).

3.4.3 Acceleration limitations.

The seat system shall protect the dummies utilized in all ejection tests conducted without exceeding the acceleration limitations specified herein. The acceleration limitations specified herein are given for acceleration measured or, during initial design verification, computed as acting at the seat bucket. The limitations pertain to the condition where the acceleration environment will not be amplified by the restraint system or seat cushion materials. The +Gz limits are defined for a probability of spinal injury of 5 percent. The limits specified for other acceleration directions are not nominal limits for a non-injury situation but are maximum limits beyond which disabling injury can be expected (see 4.5.1, 4.5.8).

MIL-DTL-9479E
w/Amendment 1

3.4.3.1 Ejection acceleration.

The acceleration imposed on the seat occupant in the +Gz direction (parallel to the spinal column) by the ejection catapult shall be limited in terms of dynamic response index (DRI) values calculated according to the method described (see 6.4.1). If the acceleration vector is not parallel (within 5°) to the z axis, the acceleration limitations specified (see 3.4.3.2) shall be used. The limits for specific catapult pre-ignition temperature and ejected weight representing the ejection seat, personal equipment, and 50th percentile human body weight are as follows (see 4.5.1, 4.5.8):

a. The mean acceleration time history generated at a pre-ignition temperature of 70°F shall not yield a DRI value in excess of 18.0 with an allowable standard deviation of 1.0.

b. The mean acceleration time history generated at a pre-ignition temperature of 165°F shall not yield a DRI value in excess of 22.0 with an allowable standard deviation of 1.0.

3.4.3.2 Acceleration after aircraft separation.

The seat acceleration due to catapult/rocket thrust and aerodynamic deceleration shall be limited to satisfy equation (1) (see 4.5.1, 4.5.8):

$$\sqrt{\left(\frac{DRI}{DRI_L}\right)^2 + \left(\frac{G_x}{G_{xL}}\right)^2 + \left(\frac{G_y}{G_{yL}}\right)^2} \leq 1.0 \quad (1)$$

where: DRI_L is the limit value of the DRI. The value of DRI_L shall be 18 unless the resultant acceleration vector is more than 5 conical degrees off the z axis and aft of the plane of the seat back, in which case the value of DRI_L shall be 16.

G_x and G_y are the acceleration magnitudes of the x and y axis components of the acceleration time history that are determined using the technique described (see 6.4.2).

G_{xL} is the limit value for the x axis (fore and aft) of figures 4, 5, and 6.

G_{yL} is the limit value for the y axis (sideways) of figure 7.

NOTE: In cases where there are acceleration components acting in the -Gz direction, the equation shall be solved using

$$\frac{-G_z}{-G_{zL}} \text{ in place of } \frac{DRI}{DRI_L}$$

where: $-G_z$ is the -z direction

$-G_{zL}$ is the limit value for the -z direction of figures 8 and 9.

**MIL-DTL-9479E
w/Amendment 1**

3.4.4 Design escape capability.

Unless otherwise specified, the seat system shall be designed to provide safe ejection as specified below, all of which shall be verified by analysis (see 4.5.1, 4.5.8):

- a. Aircraft performance envelope - Unless otherwise stated, all flight attitudes and load factors within the design limit and velocity-attitude envelope of the aircraft except maximum velocity shall be 600 KEAS,.
- b. Zero altitude (level flight) - From zero airspeed to 600 KEAS, or the maximum velocity of the aircraft, unless otherwise stated.
- c. Low level - At low altitude, adverse attitude conditions including those specified in table I.

TABLE I. Low Level Escape Performance¹

Altitude (Feet)	Velocity (Knots)	Attitude	
		Fore and Aft	Roll Angle
0 ²	120	Level	60°
200	150	Level	180°
300 ³	150	Level	0°
500	200	60° Nose down	0°
500	450	30° Nose down	0°
550	200	60° Nose down	60°
600	250	45° Nose down	180°

1/ The cited conditions are at the initiation of the ejection sequence

2/ Aircraft impact with the ground occurs at instant of seat-aircraft separation

3/ 10,000-foot-per-minute sink rate

d. CG locations - Under the conditions specified, (see 3.4.4 a, b, and c) the cg location for any crew member from the 5th to 95th percentile, with flight clothing, survival, and personal equipment, as shown on figure 2.

3.4.5 Performance.

3.4.5.1 Reliability.

The minimum acceptable probability of success is 0.98 at the 90-percent lower confidence limit. A reliability analysis shall be conducted and shall include the following (see 4.5.1, 4.5.9):

- a. Full description of the component parts to be used in the seat system, with logic diagrams and functional block diagrams to show the relationships of the components to the reliability of the seat system.
- b. Specific techniques used for allocating quantitative requirements to the components, and the allocated values.

**MIL-DTL-9479E
w/Amendment 1**

c. Analysis of potential modes of failure, their probable cause and effects on performance and reliability, the severity of these effects, the probability of occurrence, and the degree of protection afforded by the design against failure occurrence or their adverse results.

3.4.5.2 Maintainability.

The seat system shall require not more than 1 man-hour of maintenance downtime per flight hour of the aircraft. Maintenance downtime shall be defined by aircraft type in the acquisition specification and varies according to the aircraft affected. The seat system shall be designed to provide the maximum degree of accessibility to components without removing the seat from the aircraft.

3.4.5.3 Proof loads.

Unless otherwise specified, the seat system shall withstand the following proof loads without permanent deformation (see 4.5.4):

- a. Front edge of seat bucket - 270 pounds downward, distributed 1.5 inches each side of centerline.
- b. Armrest - 135 pounds downward, 4 inches aft of forward edge.
- c. Ejection controls - 200 pounds tension, center of gripping surface.
- d. Headrest - 330 pounds aft, distributed over 2-inch square area at center of headrest.
- e. . Seat back - 1,000 pounds aft, perpendicular to surface, uniformly distributed (below the headrest).

3.4.5.4 Ultimate loads.

Unless otherwise specified, the seat system shall withstand the following ultimate loads without fracture of materials or failure of attachments (see 4.5.4):

- a. Front edge of seat bucket - 400 pounds downward, distributed 1.5 inches each side of centerline.
- b. Armrest - 200 pounds downward, 4 inches aft of forward edge.
- c. Ejection controls - 300 pounds tension, center of gripping surface.
- d. Headrest - 500 pounds aft, distributed over 2-inch square area at center of headrest; 40 times the weight of the headrest assembly forward, through the cg of the headrest assembly.
- e. Seat back - 1,500 pounds aft, perpendicular to surface, uniformly distributed (below the headrest).
- f. Restraint subsystem - 8,600 pounds forward, through the occupant cg; 20° to each side of forward; and 1,750 pounds downward, through the occupant cg.
- g. Seat system - 8,600 pounds plus 40 times the seat system weight forward and 20° to each side of forward, respectively, through the occupant and seat system combination cg, and 4,300 pounds plus 25 times the seat system weight downward, through the occupant and seat system combination cg.
- h. Ejection airload - The ejection airload (simulating the dynamic pressure loads imposed upon the seat and its occupant by windblast during ejection from the aircraft) as applied normal

**MIL-DTL-9479E
w/Amendment 1**

to the centerline of the rollers (or slide blocks) and through the combined center of pressure of the exposed portion of the seat and its occupant, distributed over that portion of the seat back exposed to the airstream. For the application of this load, the seat shall be positioned on the rails (or slide blocks) in the most structurally critical position. The ejection airload shall be applied simultaneously with the applicable rocket-catapult load. The ejection airload shall be computed in accordance with conventional methods of aerodynamic computation and shall be subject to approval by the procuring activity. The critical condition for computation of the ejection airload shall be assumed to be the maximum free-stream dynamic pressure associated with the ejection seat system performance. Unless otherwise specified, the computed load shall be considered an ultimate load at maximum aircraft speed or 600 KEAS, whichever is less.

3.4.5.5 Environmental conditions.

The seat system shall be capable of satisfactory operation under the following conditions and shall withstand the applicable tests specified in section 4 without degradation in performance (see 4.5.6):

- a. Operation at temperature from -65° to 160°F (see 4.5.6.1, 4.5.6.2).
- b. Vibration which may be experienced within the aircraft structural limits (see 4.5.6.3).
- c. Exposure to salt-laden atmosphere (see 4.5.6.4).
- d. Exposure to a warm, highly humid atmosphere as encountered in tropical climates (see 4.5.6.5).
- e. Exposure to rainfall as encountered in any locale (see 4.5.6.6).
- f. Shock which may be experienced within the mechanical shock environment expected in service use. The seat shall not become detached from the attachment points during crash safety shock conditions as specified (see 4.5.6.9).
- g. Exposure to dust (see 4.5.6.8).
- h. Explosive decompression conditions which may be encountered in service use (see 4.5.6.10).

3.4.6 Materials, construction, corrosion protection treatments, and finishes.

3.4.6.1 Lubrication.

Lubrication shall function satisfactorily within the temperature range of -65° to +200°F (see 4.5, 4.5.2).

3.4.6.2 Metals.

Metals shall be of the corrosion-resistant type or treated to resist corrosion due to fuels, salt spray, or atmospheric conditions which may be encountered during normal service (see 4.5).

3.4.6.2.1 Heat treatment.

The heat treatment of aluminum and steel parts, if accomplished, shall be in accordance with ASTM B597 and SAE AMS 2759, respectively (see 4.5.2).

**MIL-DTL-9479E
w/Amendment 1****3.4.6.2.2 Castings.**

| Castings shall conform to SAE-AMS- 2175 (see 4.5.2).

3.4.6.2.3 Protective chemical treatment of metals.

If aluminum alloy parts are utilized, they shall be anodically treated in accordance with SAE AMS 2470. If non-corrosion-resistant steel parts are utilized, they shall be zinc plated in accordance with ASTM B633. If magnesium alloy parts are utilized, they shall be protected from corrosion in accordance with SAE AMS 2475 (see 4.5.2).

3.4.6.2.4 Protective organic treatment of metals.

Subsequent to the application of approved chemical treatment, all exposed metal surfaces shall be given at least one coat of primer compatible with topcoat selected. A minimum of two coats of aircraft quality topcoat shall be applied over all epoxy primer-treated surfaces of the basic ejection seat. If environmental regulations permit, the use of a high solids polyurethane is acceptable (see 4.5.2).

| 3.4.6.3 (paragraph number skipped)

3.4.6.4 Nonmetallic materials.

Materials that are nutrients for fungi shall not be used in the construction of the seat system. The material shall be capable of withstanding the wear and handling incident to normal service usage (see 4.5.2).

3.4.6.4.1 Fungus.

All nonmetallic materials used in the construction of the seat system shall withstand exposure to fungi without deterioration when tested as specified (see 4.5.6.12).

3.4.6.4.2 Flame resistance.

All nonmetallic materials shall meet the flame-resistance test specified (see 4.5.7).

3.4.6.5 Construction.**3.4.6.5.1 Methods.**

Riveting, welding, or other suitable attachment methods may be used in the construction of the seat system where permanent attachments are required. Fittings and joints requiring disassembly for maintenance shall be attached by bolting or other suitable removable attachment (see 4.5.2).

3.4.6.5.2 Projections.

The seat system shall be free of any projections or sharp edges which could snag, jam, or damage clothing and equipment, injure the seat occupant or maintenance personnel, foul personal equipment, jeopardize operation of seat components, or interfere with recovery parachute operation attachment (see 4.5.2).

**MIL-DTL-9479E
w/Amendment 1**

3.4.6.5.3 Workmanship.

The seat system, including all parts and accessories, shall be constructed in accordance with commonly accepted industrial workmanship standards attachment (see 4.5.2).

3.4.6.5.4 Drain holes.

Drain holes shall be provided in the bottom of the seat bucket and in any enclosures where water could accumulate (see 4.5.2).

3.4.6.6 Colors.

Unless otherwise specified, the color of the basic ejection seat shall be medium gray, color 36231 of FED-STD-595. The headrest and armrest upholstery shall be black, color 37038. The ejection controls shall have alternate stripes of 3/4-inch wide orange-yellow, color 13538, and 1/4-inch wide black, color 37038 (see 4.5.2).

3.4.6.7 Identification of product.

Equipment, assemblies, and pans shall be marked for identification in accordance with MIL-STD-130. A nameplate, permanently and legibly marked in accordance with MIL-STD-130, shall be securely attached to the ejection seat in a location where it can be read without removal of the seat from the aircraft attachment (see 4.5.2).

3.4.6.8 Identification of transmission hose, lines and fluid lines.

All ballistic transmission hose, detonating transmission lines, and fluid lines shall be marked for identification in accordance with procuring activity instructions (see 4.5.2, 6.2).

3.4.6.9 Materials.

All materials used shall be of the highest quality, of the lightest practicable weight, and suitable for the purpose intended (see 4.5.2).

**MIL-DTL-9479E
w/Amendment 1**

4. VERIFICATION

4.1 Classification of inspections.

The inspection requirements specified herein are classified as follows:

- a. First article inspection (see 4.3).
- b. Conformance inspection (see 4.4). Conformance inspection shall be performed on the number of ejection seats required (see 4.4.2.2) and shall be performed using the cross-index of requirements to inspections shown in table II.

TABLE II. Paragraph Cross Reference of Requirements and Verifications

RQMT	VERIFICATION	RQMT	VERIFICATION	RQMT	VERIFICATION
3.1	4.4	3.2.13.5	4.5.1, 4.5.7	3.4.6.1	4.5, 4.5.2
3.2.1	4.4.1.a, 4.5.1	3.2.13.6	4.4.2.c, 4.5.5	3.4.6.2	4.5
3.2.1.1	4.5.2	3.2.14	4.4.1.b, 4.5.3	3.4.6.2.1	4.5.2
3.2.1.2	4.5.2	3.2.15	4.5.8	3.4.6.2.2	4.5.2
3.2.2	4.4.1.a, 4.5.1	3.2.16	4.5.2	3.4.6.2.3	4.5.2
3.2.3	4.4.1.a, 4.5.1	3.2.17	4.5.8	3.4.6.2.4	4.5.2
3.2.4	4.4.1.a, 4.5.1	3.2.17.1	4.5.8	3.4.6.4	4.5.2
3.2.4.1	4.4.1.a, 4.5.1	3.2.18	4.5.8	3.4.6.4.1	4.5.6.12
3.2.5	4.4.1.a, 4.5.1	3.2.18.1	4.5.1, 4.5.8	3.4.6.4.2	4.5.7
3.2.6	4.4.1.a, 4.5.1	3.2.18.2	4.5.1, 4.5.8	3.4.6.5.1	4.5.2
3.2.7	4.4.1.a, 4.5.1	3.2.19	4.5.1	3.4.6.5.2	4.5.2
3.2.8	4.4.1.a, 4.5.1	3.2.19.1	4.5.1	3.4.6.5.3	4.5.2
3.2.9	4.4.1.a, 4.5.1	3.3.1	4.5.2	3.4.6.5.4	4.5.2
3.2.10	4.4.1.a, 4.5.1	3.3.2	4.5.2	3.4.6.6	4.5.2
3.2.11	4.5.1, 4.5.6.11	3.3.3	4.5.2	3.4.6.7	4.5.2
3.2.11.2	4.5.1, 4.5.6.11	3.4.1	4.5.6.11	3.4.6.8	4.5.2
3.2.11.3	4.5.1, 4.5.6.11	3.4.2	4.5.8	3.4.6.9	4.5.2
3.2.11.4	4.5.1, 4.5.6.11	3.4.3.1	4.5.1, 4.5.8		
3.2.11.5	4.5.1	3.4.3.2	4.5.1, 4.5.8		
3.2.12	4.5.1, 4.5.6.11	3.4.4	4.5.1, 4.5.8		
3.2.13	4.5.1, 4.5.8	3.4.5.1	4.5.1, 4.5.9		
3.2.13.1	4.5.1, 4.5.8	3.4.5.2	4.5.1, 4.5.10		
3.2.13.2	4.5.1	3.4.5.3	4.5.4		
3.2.13.3	4.5.1	3.4.5.4	4.5.4		
3.2.13.4	4.5.1	3.4.5.5	4.5.6		

**MIL-DTL-9479E
w/Amendment 1**

4.2 Test conditions.

Unless otherwise specified, all tests required by this specification shall be made at an ambient pressure of 28 to 32 inches of mercury, a temperature of $75^{\circ} \pm 20^{\circ}\text{F}$, and a relative humidity of 80 percent or less. When tests are made with atmospheric pressure, temperature, or humidity substantially different from the above values, proper allowances shall be made for the change in instrument readings.

4.3 First article inspection.

First article inspection shall consist of all examinations and tests described (see 4.5).

4.3.1 First article samples.

The first article samples shall consist of

- a. One complete ejection seat system unless otherwise indicated in the approved preproduction test plan.
- b. Material samples as required to conduct the material tests specified herein.

4.3.2 4.3.2 Order of testing.

Unless otherwise specified, tests shall be conducted in the following order:

- a. Any required component tests.
- b. Structural and environmental tests.
- c. Ground, track, and flight escape tests.

4.4 Conformance inspection.

Conformance inspection shall consist of

- a. Individual inspection (see 4.4.1).
- b. Sampling inspection (see 4.4.2).

4.4.1 Individual inspection.

Each seat system shall be subjected to the following as described (see 4.5):

- a. Examination of product (see 4.5.2).
- b. Ballistic gas transmission (4.5.3).

4.4.2 Sampling inspection.

The sampling inspection shall consist of the following as described (see 4.5):

- a. Examination of preparation for delivery.
- b. Structural strength.
- c. Ejection control forces.

**MIL-DTL-9479E
w/Amendment 1**

4.4.2.1 Inspection lot.

An inspection lot shall be expressed in units of complete ejection seat systems manufactured under essentially the same conditions and submitted for acceptance at substantially the same time.

4.4.2.2 Sampling plan.

Sample seats shall be selected at random from each lot on the same material order, in the quantities specified below:

- a. Two seats from each lot of 400 or fraction thereof.
- b. Three seats from each lot of 401 to 800.
- c. One seat from each additional 800 or fraction thereof, above 800.

4.4.2.3 Rejection and retest.

Failure of any seat to pass the acceptance tests shall be cause for rejection of the entire lot represented. If in the opinion of the inspector, such failure is attributable to faulty workmanship or other defects not likely to occur throughout the lot, the contractor must test three additional seats selected at random from the lot. Failure of any one of these additional seats shall be cause for the rejection of the entire lot represented.

4.5 Inspection methods.

4.5.1 Design verification.

On-going verification of the seat system escape design shall be accomplished through use of a 6-degree-of-freedom (6DOF) computer program. The computer simulation program shall be presented at all program reviews, internal and external, at the request of the government. The program shall be employed as a design growth display reflecting the maturing design approach, materials, and test plan basis. A maximum amount of actual test data available from system tests shall be used to refine the computer program.

4.5.2 Examination of product.

Each seat system shall be carefully examined to determine conformance to this specification and applicable drawings with respect to materials, workmanship, standard parts, weight, finish, adjustments, dimensions, and markings. Special attention shall be given to the ejection control mechanism.

4.5.3 Ballistic gas transmission.

The ballistic gas transmission hose and fittings shall be subjected to a flow test, based upon the design schematic of the ballistic subsystem. The plumbing connections to the propellant-actuated devices shall be disconnected for the performance of this test. The testing material used shall be dry air or dry nitrogen at a pressure not greater than 450 psig. There shall be no flow condition or restriction of flow which is not in accordance with the design schematic (see 3.2.14).

**MIL-DTL-9479E
w/Amendment 1**

4.5.4 Structural strength.

The ejection seat shall be mounted on the ejection rails and retained in a test jig which simulates the attachments and interfaces of the ejection seat and rails within the aircraft structure. Under these conditions, the seat system shall be subjected to and shall withstand the required ultimate loads for preproduction inspection and the required proof loads for sampling inspection as specified (see 3.4.5.3 and 3.4.5.4). These loads shall be applied to the seat without cushions. The loads may be applied by means of hydraulic or pneumatic presses, jacks, shot bags, or other suitable methods. The restraint subsystem shall be tested by applying the loads to a block or frame fitted within the seat and held in place by the restraint subsystem. The block or frame shall be formed to simulate operational use of the restraint subsystem.

4.5.5 Ejection control forces.

Each ejection control handgrip shall be actuated. The force required for actuation shall be measured and shall meet the requirements specified (see 3.2.13.2).

4.5.6 Environmental tests.

Environmental testing shall be planned and conducted under the guidance of DO-160C (RTCA/FAA) (see 3.4.5.5).

4.5.6.1 High temperature.

The seat system shall be subjected to a high temperature test in accordance with DO-160, Section 4, Category D1, Operating High Temperature Test, using a constant ambient temperature exposure of 160°F. Operation of the seat shall include the ejection controls, seat adjustment, inertia reel control, emergency oxygen, and manual parachute release.

4.5.6.2 Low temperature.

The seat system shall be subjected to a low temperature test in accordance with DO-160, Section 4, Category D1, Ground Survival Low Temperature Test and Operating Low Temperature Test using a constant ambient temperature of -65°F. Operation of the seat shall include the ejection controls, seat adjustment, inertia reel control, emergency oxygen, and manual parachute release.

4.5.6.3 Vibration.

The seat system shall be subjected to a vibration test in accordance with DO160, Section 8, Standard and Random Vibration. The vibration profile shall be in accordance with the established or projected profile for the specific aircraft or application. Equipment operation shall include operation of the ejection controls, seat adjustment, and inertia reel control.

4.5.6.4 Salt fog.

The seat system shall be subjected to a salt fog test in accordance with DO-160, Section 14, Category S, 5% Salt Spray. Equipment operation shall include operation of the ejection controls, seat adjustment, inertia reel control, emergency oxygen, and manual parachute release.

4.5.6.5 Humidity.

The seat system shall be subjected to a humidity test in accordance with DO160, Section 6, Category A. Equipment operation shall include operation of the ejection controls, seat

**MIL-DTL-9479E
w/Amendment 1**

adjustment, inertia reel control, emergency oxygen, and manual parachute release. In addition, these operations shall be performed at the end of five cycles (120 hours) with the condensation remaining on the seat system.

4.5.6.6 Rain.

The seat system shall be subjected to a rain test in accordance with DO-160, Section 10, Category R, Spray Proof Test to simulate blowing rain. Equipment operation shall include operation of the ejection controls, seat adjustment, inertia reel control, emergency oxygen, and manual parachute release.

4.5.6.7 Temperature shock.

The seat system shall be subjected to a temperature shock test in accordance with DO-160, Section 5, Category B. Operation of the seat shall include operation of the ejection controls, seat adjustment, inertia reel control, emergency oxygen, and manual parachute release.

4.5.6.8 Dust.

The seat system shall be subjected to a dust test in accordance with DO-160, Section 12, Category D. Note; if 140 mesh silica flour is used, local environmental criteria must be observed. Operation of the seat shall include operation of the ejection controls, seat adjustment, inertia reel control, emergency oxygen, and manual parachute release.

4.5.6.9 Shock.

The seat system shall be subjected to a shock test in accordance with DO-160, Section 12, Operational and Crash Safety. The shock pulse shape shall be a 20 g pulse and a time duration of 6-9 ms. Equipment operation shall include operation of the ejection controls, seat adjustment, and inertia reel control.

4.5.6.10 Explosive decompression.

The seat system shall be subjected to an explosive decompression from 8,000 feet equivalent altitude to the maximum cruise altitude of the aircraft within 100 milliseconds. After this exposure, operation of the ejection controls, seat adjustment, and inertia reel control shall be tested.

4.5.6.11 Windblast.

The seat system, with a dummy properly restrained for ejection, shall be exposed to windblast of 600 \pm 20 KEAS (or maximum aircraft airspeed \pm 3 percent, if less than 600 KEAS) for a minimum of 0.3 seconds in each of the following attitudes, emerging into the airstream during ejection, unless otherwise stated:

- a. Fully exposed, in line with guide rails
- b. 45° rotation to right
- c. 90° rotation to right
- d. 45° rotation to left
- e. 90° rotation to left
- f. 30° pitch forward
- g. 30° pitch aft

**MIL-DTL-9479E
w/Amendment 1**

Photographic coverage of each windblast exposure test shall include a minimum of two high-speed motion picture cameras (2,000 frames per second, or greater), located to provide maximum coverage of exposed portions of the seat system. No conditions which would adversely affect the capability for successful seat ejection shall occur during test windblast exposure (see 3.4.1).

4.5.6.12 Fungus.

Samples of all nonmetallic materials used in the construction of the seat system shall be subjected to a fungus test in accordance with DO-160, Section 13.

4.5.7 Flame resistance.

Samples of all upholstery and cover material shall be tested in accordance with method 5906 of FED-STD-191. The burning rate shall not exceed 4 inches per minute. In addition, if the specimens do not support combustion after the ignition flame is applied for 15 seconds, or if the flame extinguishes itself and subsequent burning without a flame does not extend into the undamaged areas, the material shall also be acceptable (see 3.2.13.5).

4.5.8 Ejection.

Ejection tests of the seat system shall be conducted in accordance with the requirements established by the acquiring agency for a specific aircraft. These requirements will include the following types of tests (see 3.2.13, 3.2.13.1, 3.2.15, 3.2.17, 3.2.17.1, 3.2.18, 3.2.18.1, 3.2.18.2, 3.4.2, 3.4.3, 3.4.3.1, 3.4.3.2, 3.4.4):

- a. System tests comprising of ejections from a combination of test aircraft and ground sleds.
- b. Wind tunnel testing to verify windblast performance.
- c. Validation of initial 6DOF computer model.

4.5.9 Reliability.

A reliability of 0.90 with a 0.90 confidence level shall be demonstrated by satisfactory completion of system tests.

4.5.10 Maintainability verification.

Time studies of all corrective maintenance tasks shall be conducted by simulating failures. Timing of each maintenance task shall be performed at least three times to determine average values. The maintenance tasks considered shall be only those related to field level maintenance. The time to accomplish each maintenance task shall include time for preparation, recognition, fault location, removal (based only on the installation provisions of the item), fault correction, adjustment and realignment, final test, and replacement, but shall exclude supply time and administrative time. In the case of repetitive subtasks which occur by the nature of the sequence of maintenance actions (e.g., removal), it shall not be necessary to redetermine the average time required. Recommended preventive maintenance tasks shall be identified, with associated required task times, based either upon time studies performed or upon experience data already available.

**MIL-DTL-9479E
w/Amendment 1**

5. PACKAGING

5.1 General.

For acquisition purposes, the packaging requirements shall be as specified in the contract or order (see 6.2). When actual packaging of materiel is to be performed by DoD personnel, these personnel need to contact the responsible packaging activity to ascertain requisite packaging requirements. Packaging requirements are maintained by the Inventory Control Point's packaging activity within the Military Department or Defense Agency, or within the Military Department's System Command. Packaging data retrieval is available from the managing Military Department's or Defense Agency's automated packaging files, CD-ROM products, or by contacting the responsible packaging activity.

**MIL-DTL-9479E
w/Amendment 1**

6. NOTES

(This section contains information of a general or explanatory nature that may be helpful, but is not mandatory).

6.1 Intended use.

The ejection seat and all subsystems described in this specification are intended to safely eject aircraft crew members from the top of an aircraft and protect them from the adverse effects of the ejection sequence. The ejection seat also provides a means of safely decelerating the crew member during decent to the ground.

6.2 Acquisition requirements.

Acquisition documents must specify the following:

- a. Title, number, and date of the specification.
- b. Issue of the documents cited in the solicitation (see 2.2.1 and 2.2.2).
- c. Packaging requirements (see 5.1).
- d. Flight clothes and personal equipment to be considered.
- e. Whether a first article sample is required (see 4.3.1).
- f. Whether canopy piercers are required.
- g. Specific requirements governed by the type of aircraft the ejection seat will be installed into.
- h. Fluid line marking requirements.
- i. Provide minimum ejection safe clearance time and verification method depending on the aircraft that the ejection seat will be installed.

6.3 Seat reference point.

The seat reference point is the point at which the centerline of the seat back surface (depressed) and seat bottom surface (depressed) intersect. When the seat is positioned at the midpoint of the adjustment range, this intersection is called the neutral seat reference point.

6.4 Techniques.

6.4.1 Determination of dynamic response index (DRI).

The DRI is representative of the maximum dynamic compression of the vertebral column of the human body. In physical terms, the DRI is calculated by mathematically describing the human body in terms of an analogous, lumped parameter mechanical model consisting of a mass, spring, and damper. The DRI is determined from equations (2) and (3).

$$\frac{d^2 \delta}{dt^2} + 2\zeta\omega_n \frac{d\delta}{dt} + \omega_n^2 \delta = \frac{d^2 z}{dt^2} \quad (2)$$

**MIL-DTL-9479E
w/Amendment 1**

$$DRI = \frac{\omega_n^2 \delta_{\max}}{g} \quad (3)$$

Where:

δ = compression of spring

ζ = 0.224 (damping ratio of the model)

ω_n = 52.9 radians/sec (undamped natural frequency of the model)

Substituting given numerical values, these equations become:

$$\frac{d^2 \delta}{dt^2} + 23.7 \frac{d\delta}{dt} + 2798\delta = \frac{d^2 z}{dt^2}$$

$$DRI = 86.9\delta_{\max}$$

6.4.2 Graphic approximation technique.

Based upon acceleration time plots from measurements or computations, the rise time, plateau duration, and g values in the x and y axes at a specific time may be obtained using the following graphic approximation technique, as shown on figure 10.

- a. Establish the calibration baseline, correcting for any gravity bias acceleration.
- b. Establish the maximum (peak) acceleration magnitude.
- c. Construct a reference line parallel to the calibration baseline at a magnitude equal to 10 percent of the peak acceleration. The intersection of this line with the acceleration time plot defines points 1 and 2.
- d. Construct a second reference line parallel to the calibration baseline at a magnitude equal to 90 percent of the peak acceleration. The intersection of this line with the acceleration time plot defines points 3 and 4.
- e. Construct the onset line defined by the straight line through points 1 and 3. f. Construct the offset line defined by the straight line through points 2 and 4.
- f. Construct a line parallel to the calibration baseline, through the peak acceleration.
- g. The time interval defined by the intersections of this line with the constructed onset and offset lines (points 5 and 6) is the plateau duration ($\underline{\Omega}$).
- h. Locate the intersection of the constructed onset line with the calibration baseline (point 7). The time interval defined by points 7 and 5 is the rise time (t_R).
- i. For a given plot of accelerations in the x and y axes, the specific g values obtained from the constructed onset and offset lines for the specific time at w summation vector of acceleration is the greatest. An example is shown on figure 11.

**MIL-DTL-9479E
w/Amendment 1**

6.5 Anthropometric data.

Anthropometric data per "Multivariate Anthropometric Method for Crew Station Design", AL/CF-TR-1993-0054 and "Multivariate Anthropometric Method for

6.6 Subject term (key word) listing.

Acceleration
Catapult
CG envelope
Dynamic response
Emergency
Escape
Rocket
Techniques

6.7 Reference material.

Further information may be obtained from DoD Handbook DH2-2, Crew Stations and Passenger Accommodations, Design Note 2A1, Subnotes 1(1) and 1(3) entitled "Cockpit-Basic Dimensions, Fixed Wing" and "Cockpit-Clearance Dimensions, Ejection Seat," respectively.

6.8 Changes from previous issue.

The margins of this amendment are marked with vertical lines to indicate where changes from the previous issue were made. This was done as a convenience only and the Government assumes no liability whatsoever for any inaccuracies in these notations. Bidders and contractors are cautioned to evaluate the requirements of this document based on the entire content irrespective of the marginal notations and relationship to the last previous issue.

**MIL-DTL-9479E
w/Amendment 1**

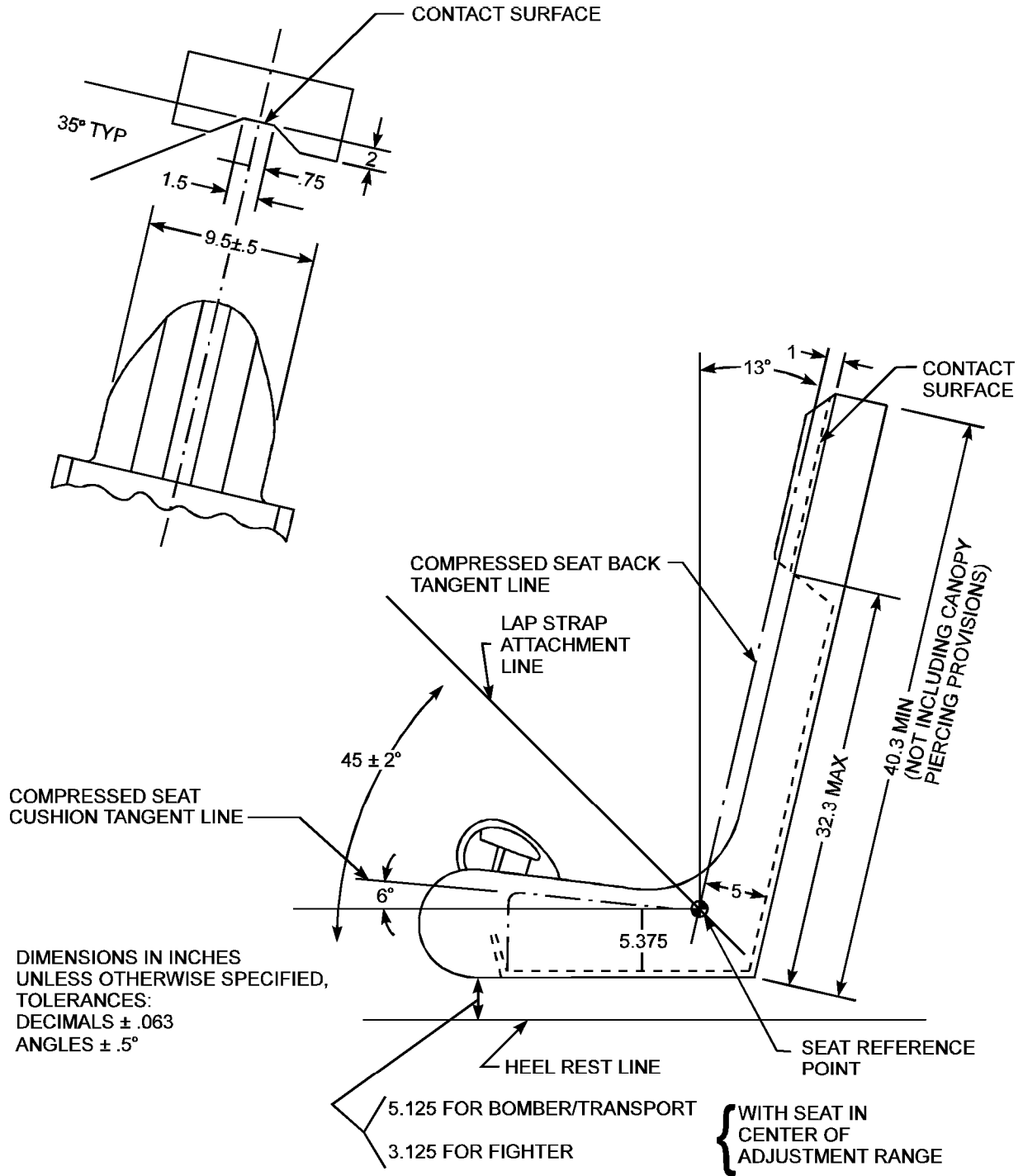

THIS ILLUSTRATION IS
FOR REFERENCE ONLY

FIGURE 1. Side view of seat with example of headrest details.

MIL-DTL-9479E
w/Amendment 1

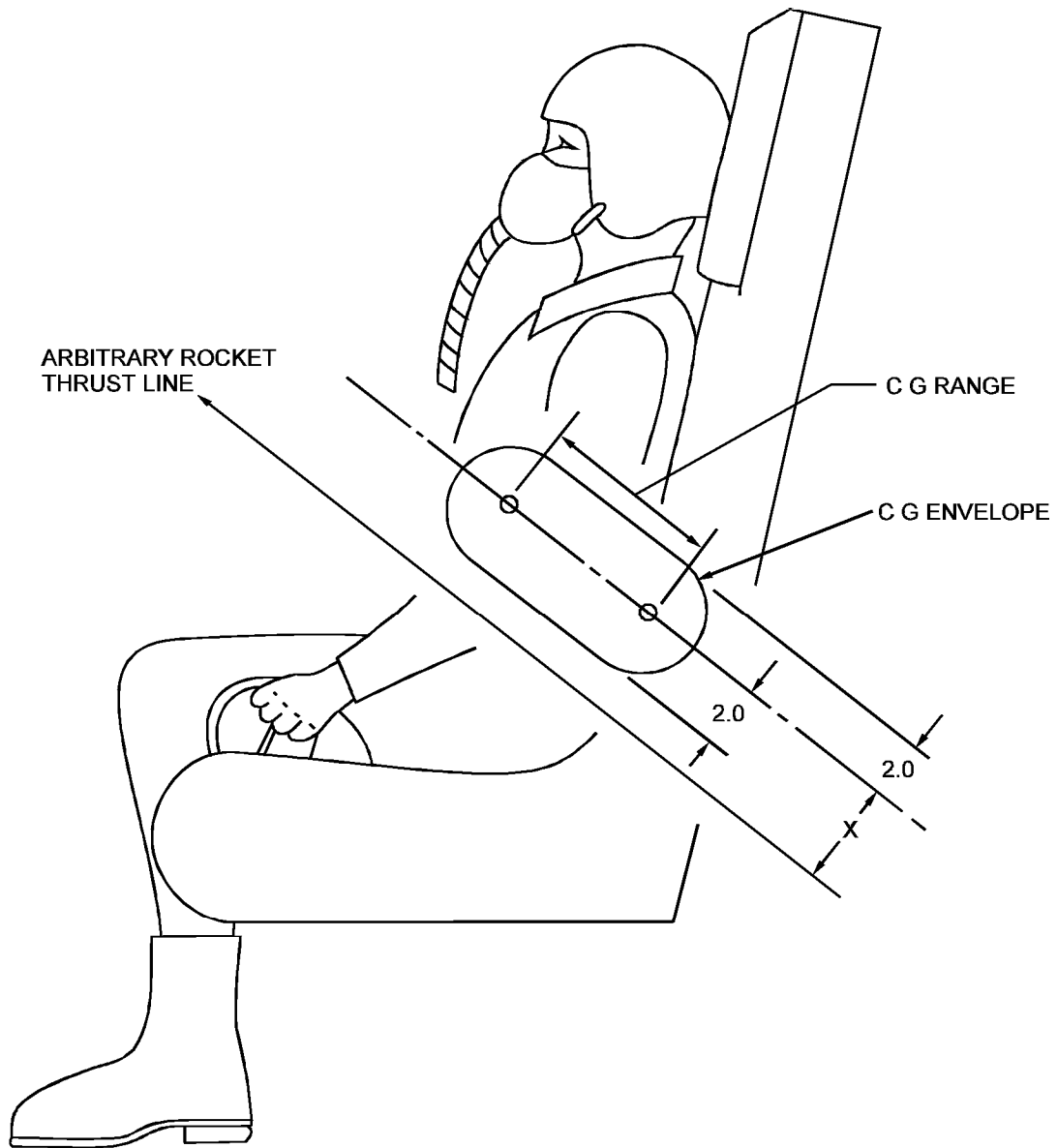

DIMENSIONS IN INCHES

THIS ILLUSTRATION IS
FOR REFERENCE ONLY

FIGURE 2. Center-of-gravity envelope example.

MIL-DTL-9479E
w/Amendment 1

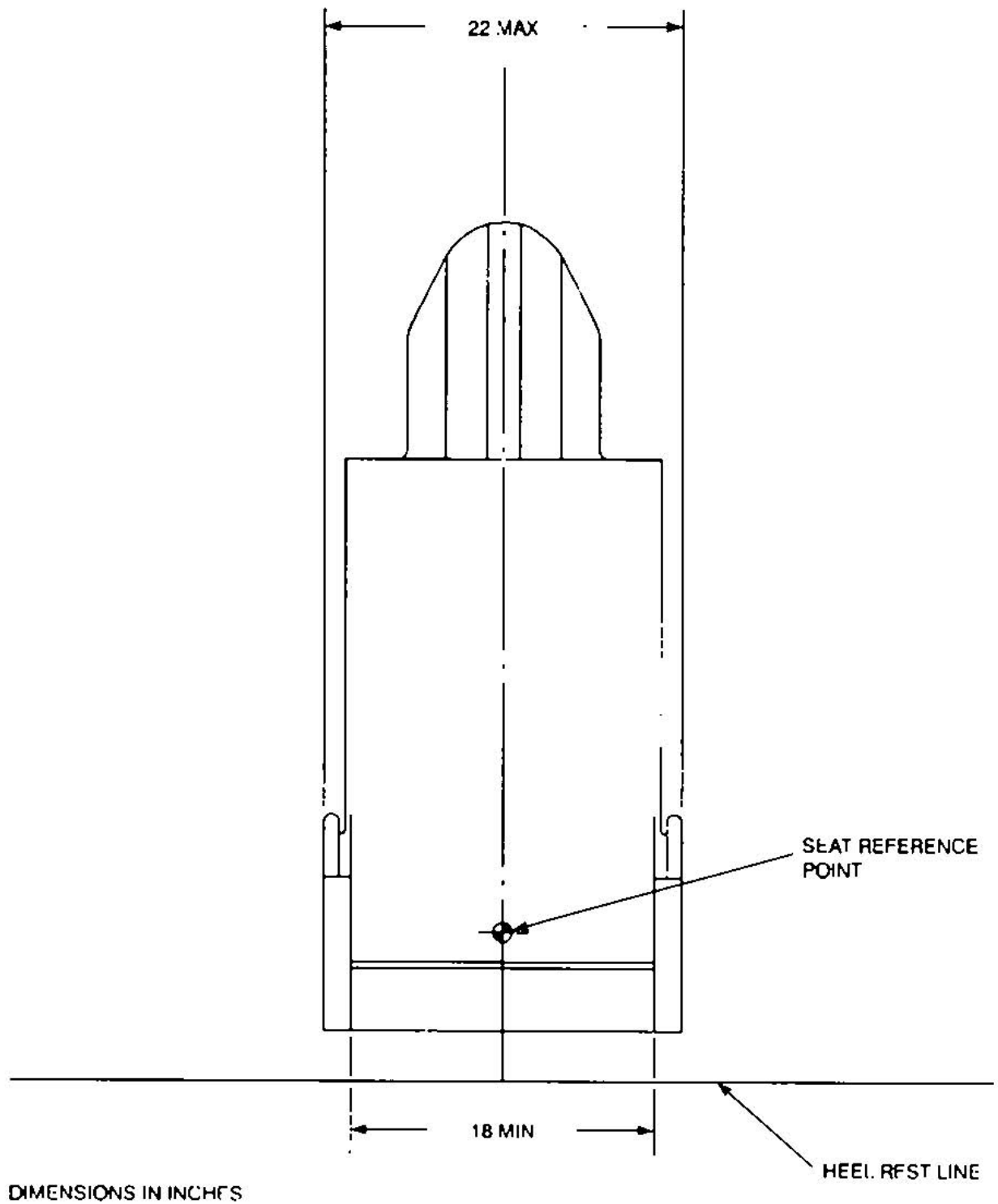

FIGURE 3. Front view of seat.

MIL-DTL-9479E
w/Amendment 1

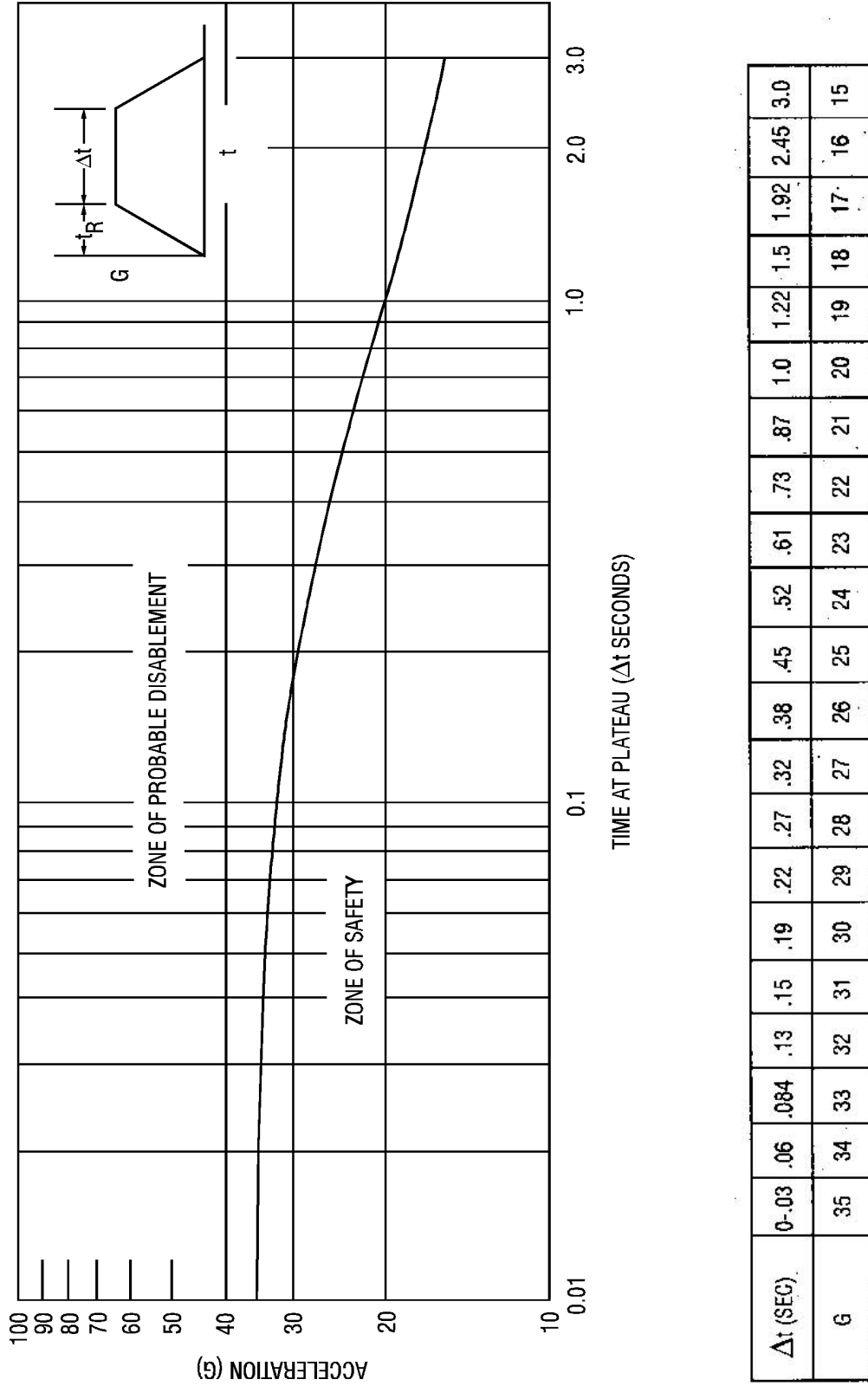

FIGURE 4. Acceleration limit (+G_{XL})(rise time = .03 sec).

MIL-DTL-9479E
w/Amendment 1

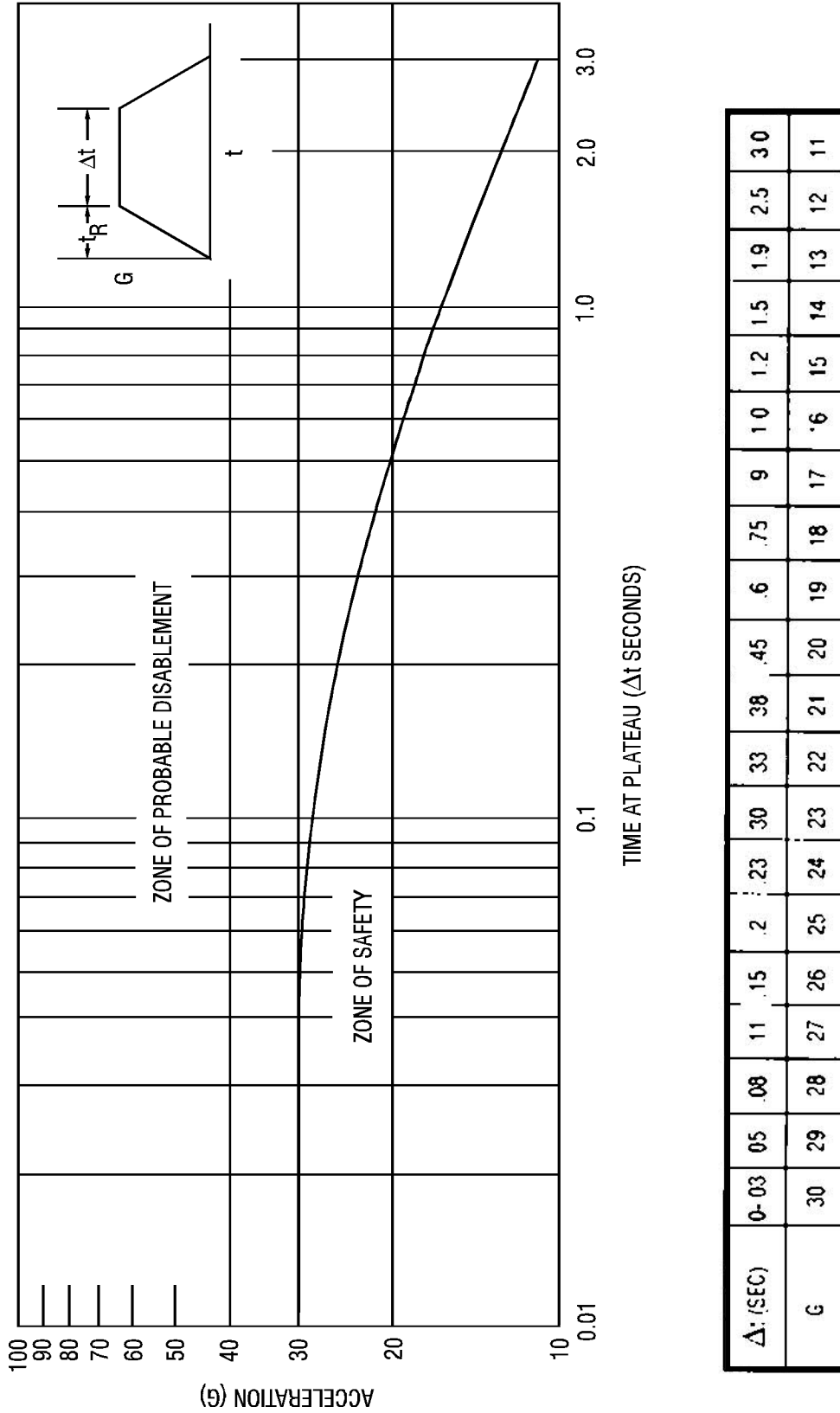

FIGURE 5. Acceleration limit ($-G_{XL}$)(rise time ≈ 0.03 sec).

MIL-DTL-9479E
w/Amendment 1

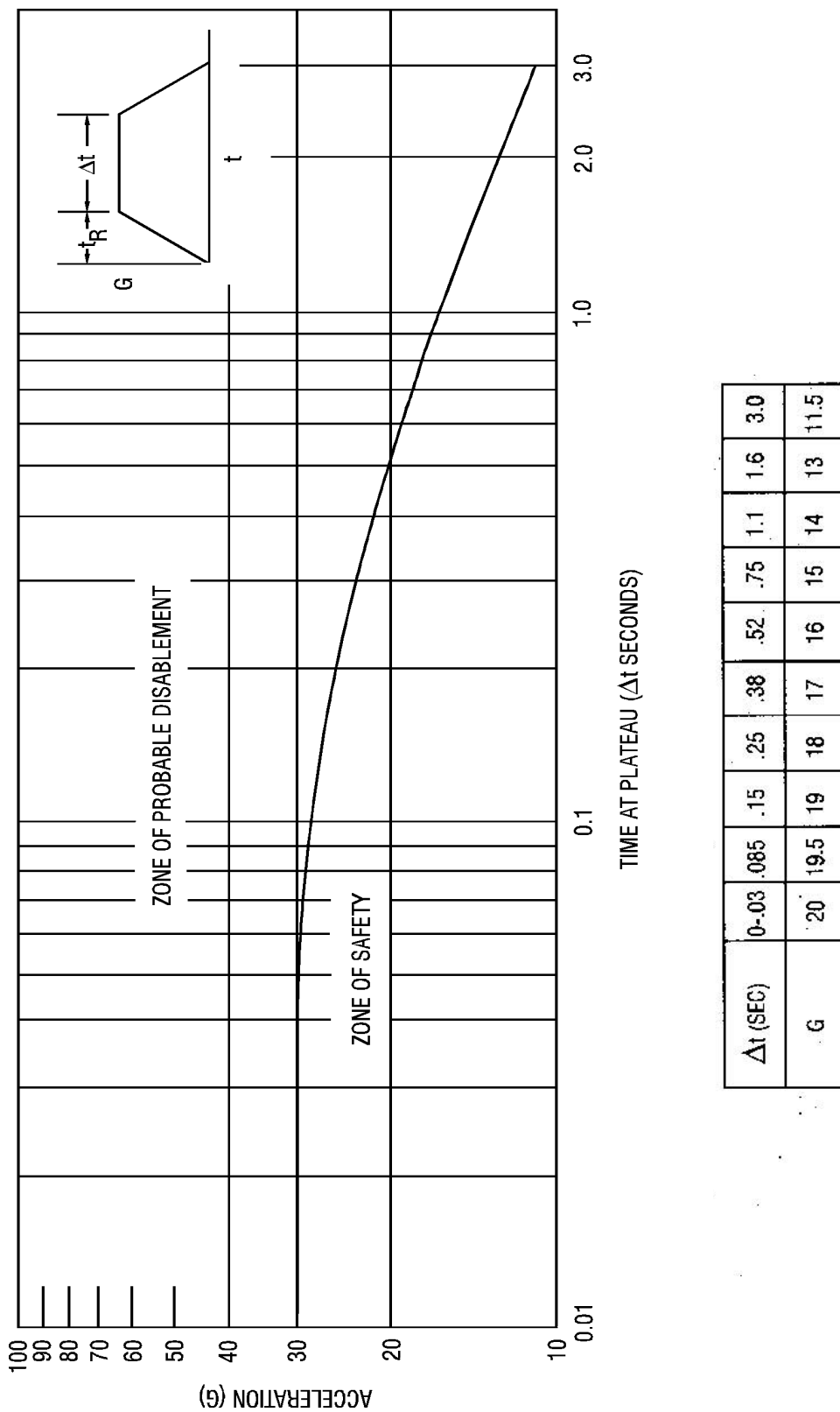

FIGURE 6. Acceleration limit ($\pm G_{x_L}$)(rise time < .03 sec).

MIL-DTL-9479E
w/Amendment 1

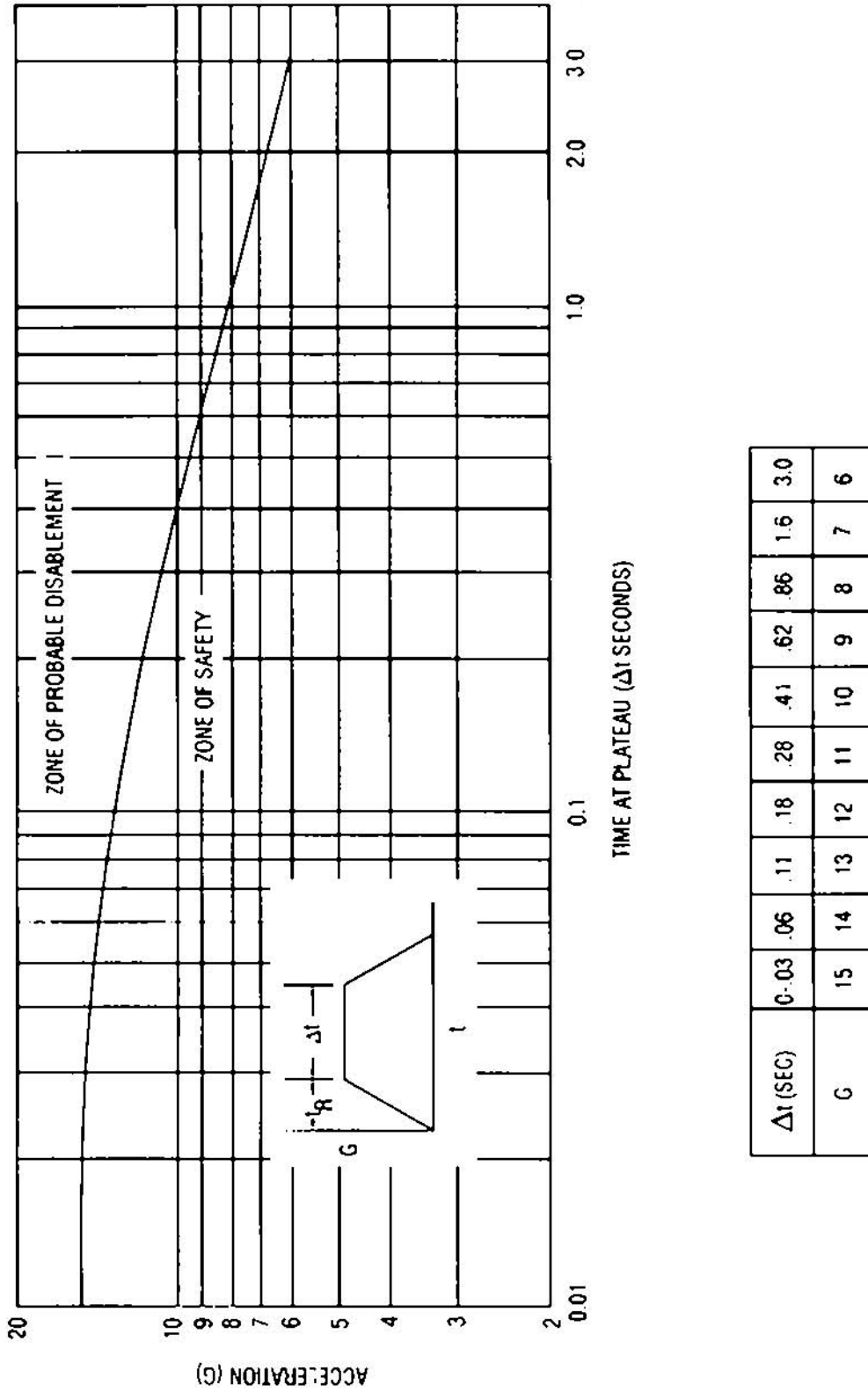

FIGURE 7. Acceleration limit ($\pm G_{VL}$)(any rise time).

MIL-DTL-9479E
w/Amendment 1

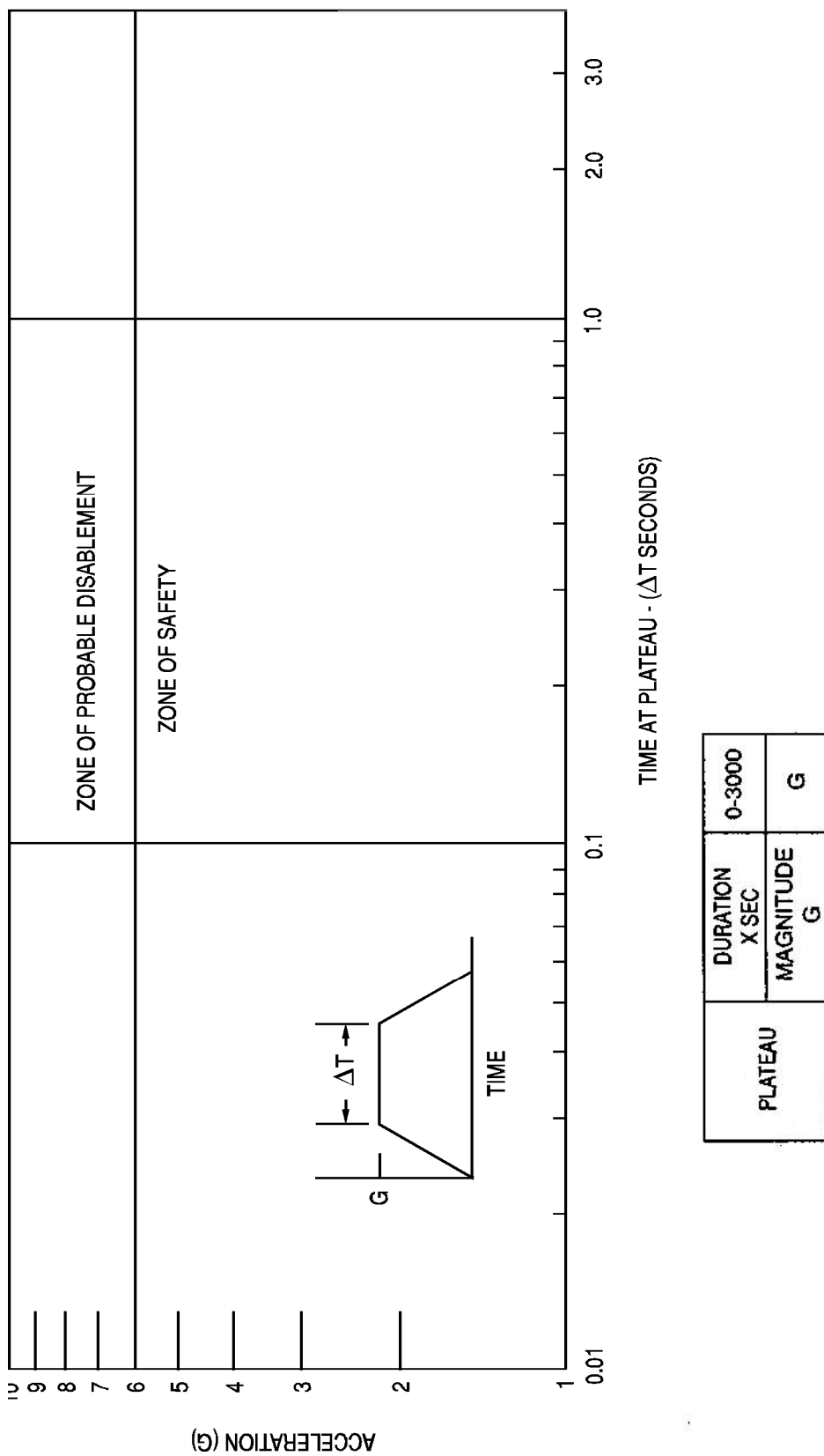

FIGURE 8. Acceleration limit for $-G_z$ (rise time < 0.04 sec).

MIL-DTL-9479E
w/Amendment 1

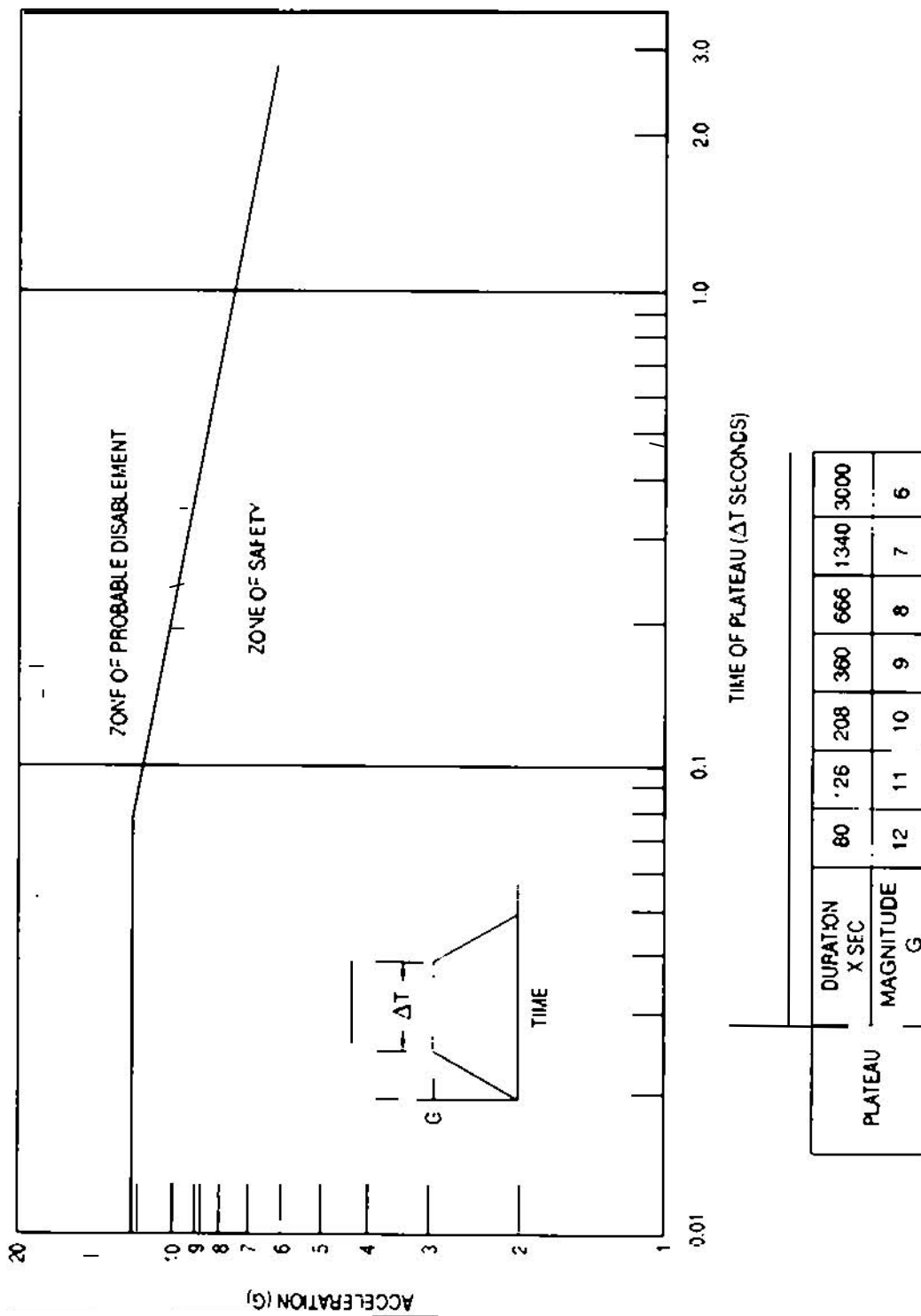

FIGURE 9. Acceleration limit for -G_z(rise time ³ 0.04sec).

MIL-DTL-9479E
w/Amendment 1

$G_{PEAK} = 20G$
 Δt PLATEAU DURATION = 0.016 SEC
 t_R RISE TIME = 0.058 SEC

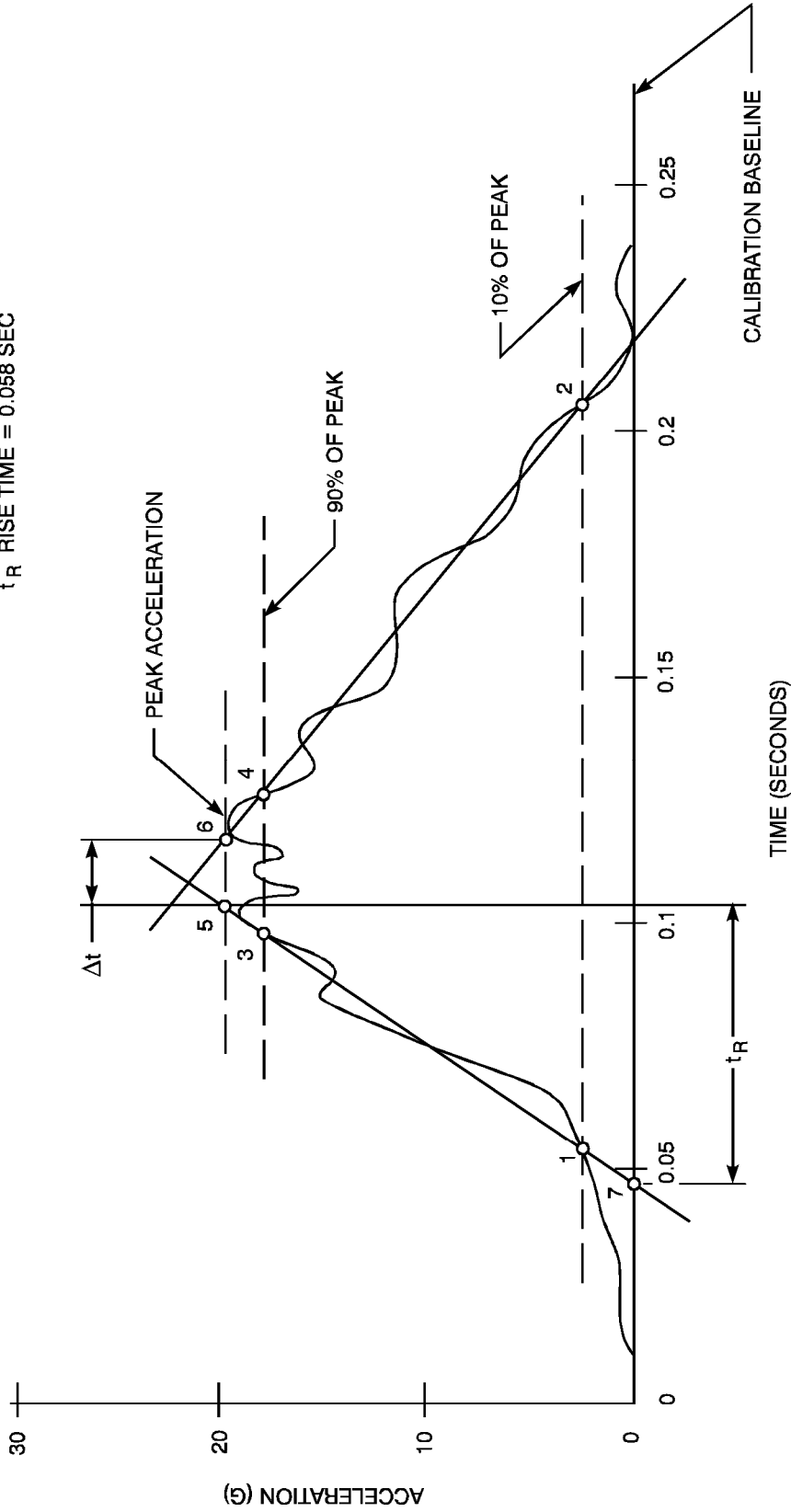

FIGURE 10. Graphic approximation technique.

MIL-DTL-9479E
w/Amendment 1

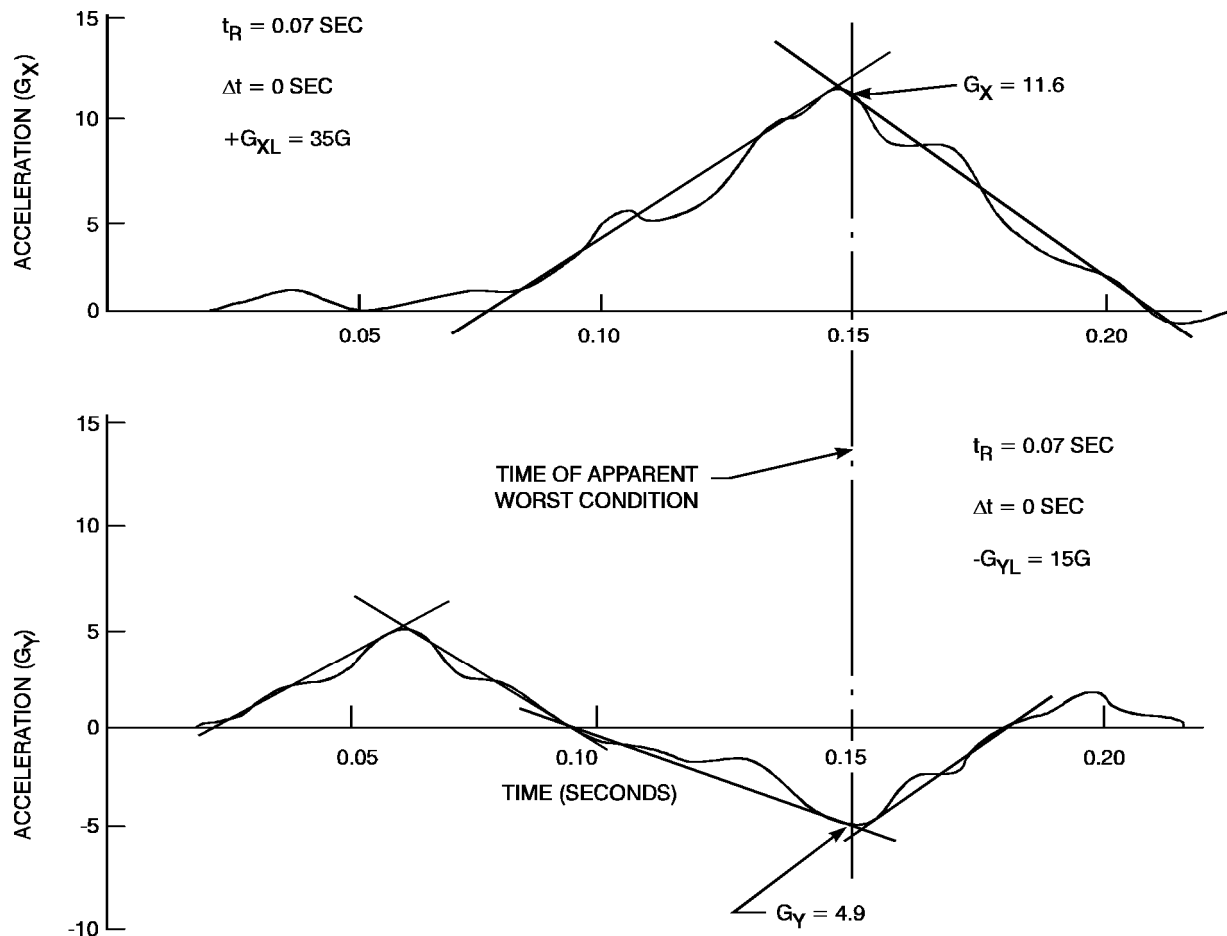

FIGURE 11. Multiaxial acceleration environment example.

Preparing activity:
Air Force - 11

Review activity:
Air Force - 99
DLA - GS

(Project 1680-2007-003)

NOTE: The activities listed above were interested in this document as of the date on the cover. Since organizations and responsibilities can change, you should verify the currency of the information above using the ASSIST Online database at <http://assist.daps.dla.mil>.