

INCH-POUND

MIL-DTL-9177/5D
 4 September 2018
 SUPERSEDING
 MIL-DTL-9177/5C(USAF)
 25 November 2002

DETAIL SPECIFICATION SHEET

CONNECTOR, AUDIO, AIRBORNE, JACK, SWITCH, 4 CONTACT

This specification is approved
 for use by all Departments and Agencies of the Department of Defense (DoD).

The requirements for acquiring the product described
 herein shall consist of this specification and MIL-DTL-9177.

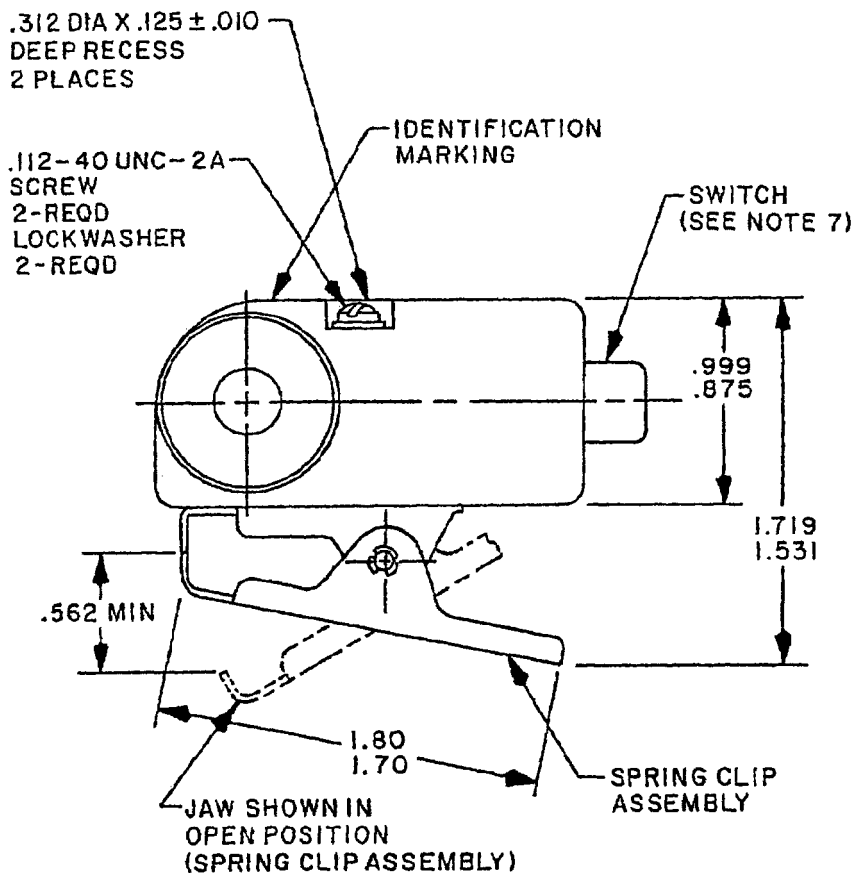

FIGURE 1. Dimensions and configurations (M9177/5-1).



MIL-DTL-9177/5D

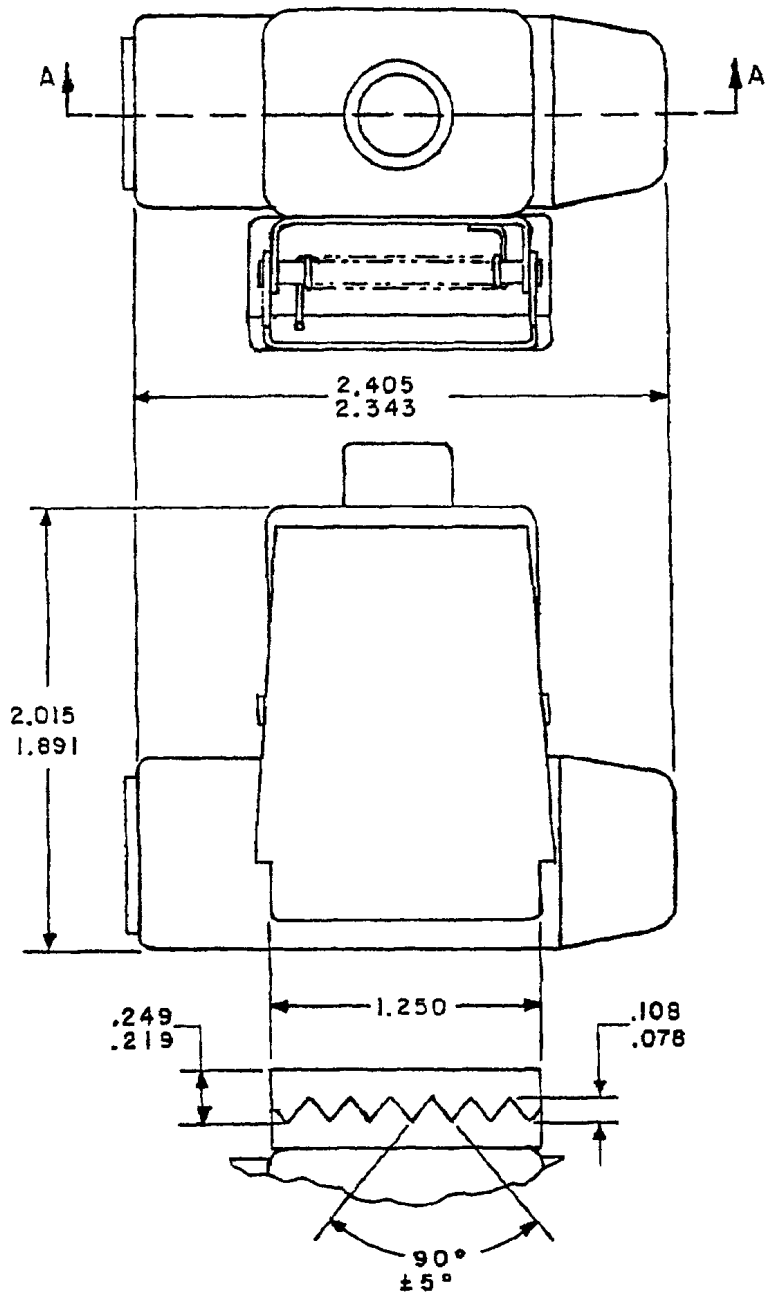

FIGURE 1. Dimensions and configurations (M9177/5-1) – Continued.

MIL-DTL-9177/5D

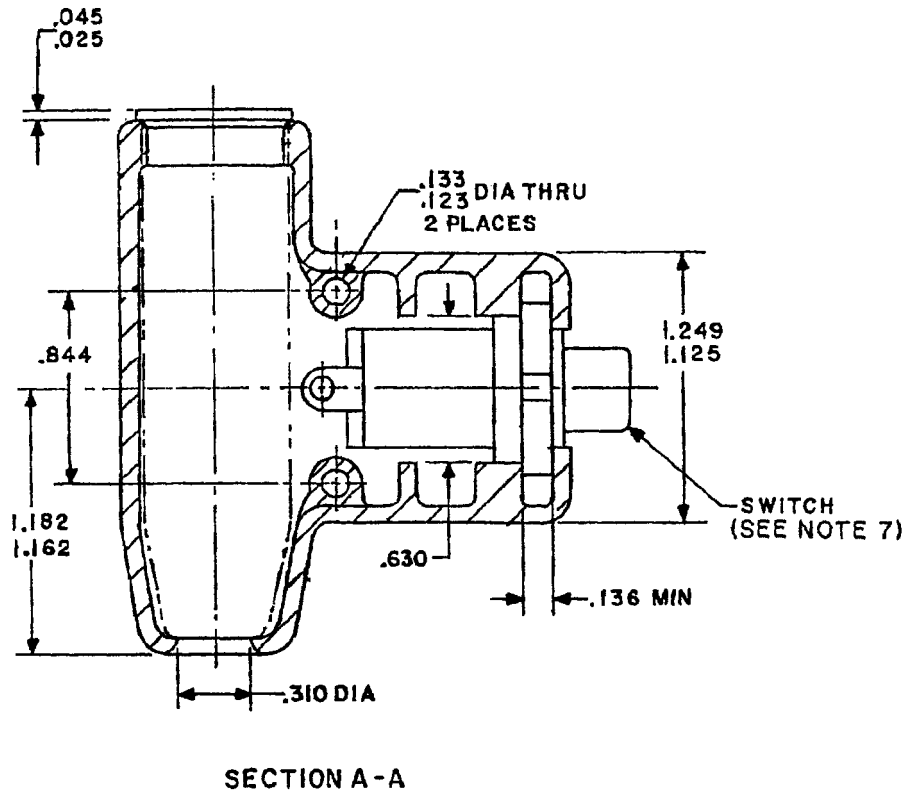

FIGURE 1. Dimensions and configurations (M9177/5-1) – Continued.

MIL-DTL-9177/5D

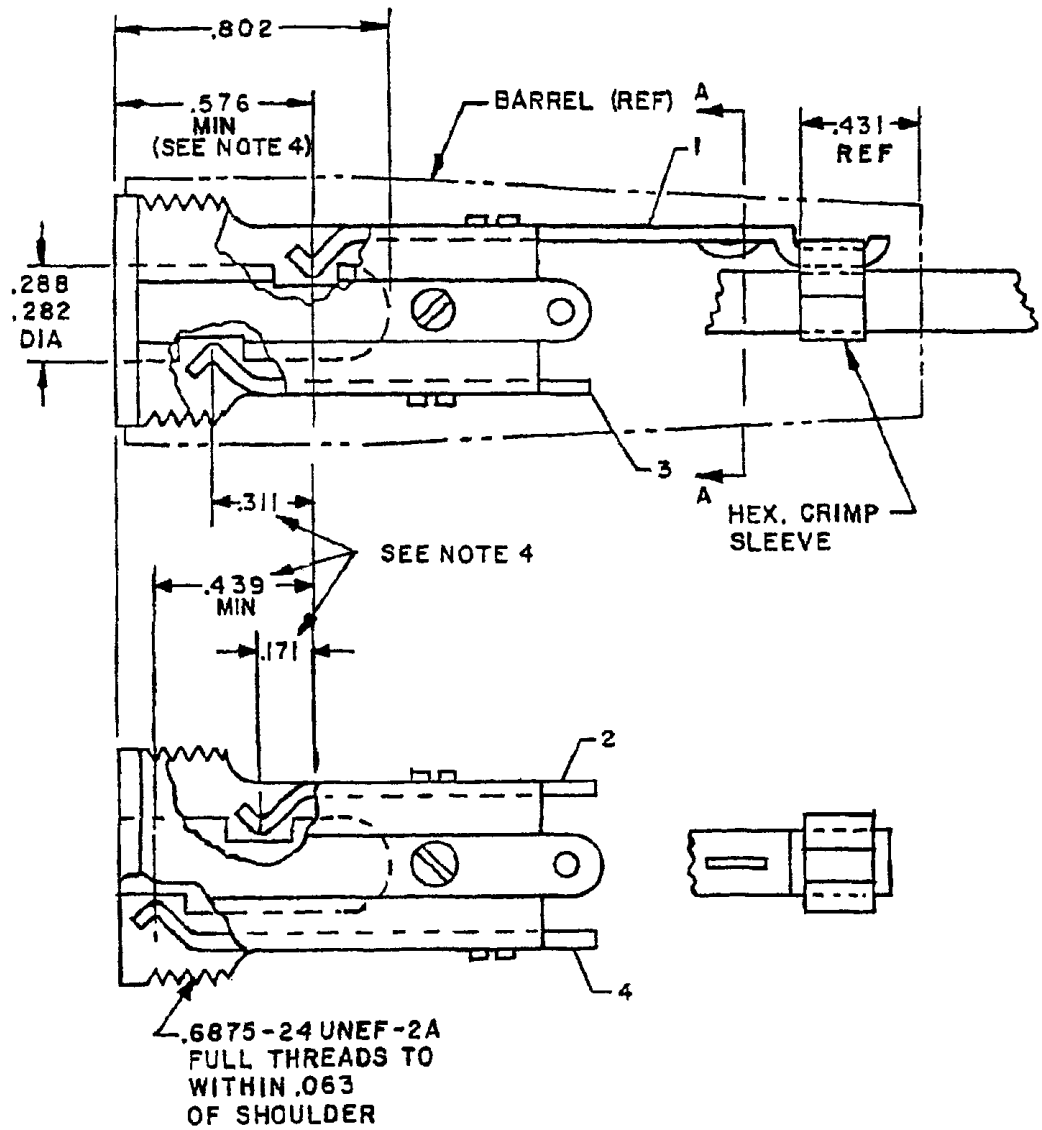
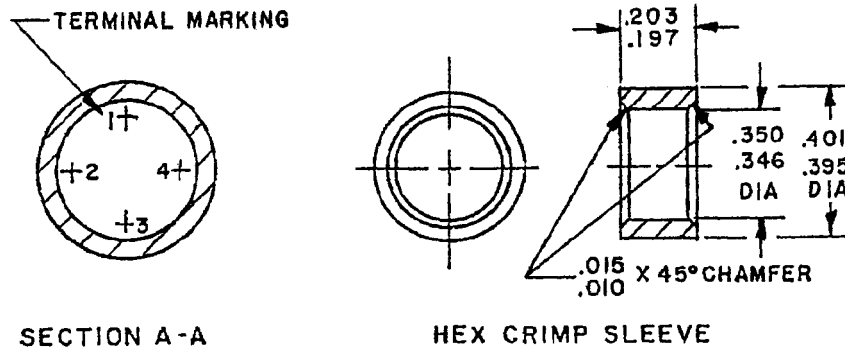

FIGURE 1. Dimensions and configurations (M9177/5-1) – Continued.

MIL-DTL-9177/5D



Inches	mm	Inches	mm	Inches	mm	Inches	mm
.010	0.25	.203	5.16	.431	10.95	1.249	31.72
.015	0.38	.219	5.56	.439	11.15	1.250	31.75
.025	0.64	.249	6.32	.562	14.27	1.531	38.89
.045	1.14	.282	7.16	.576	14.63	1.70	43.2
.078	1.98	.288	7.32	.630	16.00	1.719	43.66
.108	2.74	.310	7.87	.802	20.37	1.80	45.7
.123	3.12	.311	7.90	.844	21.44	1.891	48.03
.125	3.18	.312	7.92	.975	24.76	2.015	51.18
.133	3.38	.346	8.79	.999	25.37	2.343	59.51
.136	3.45	.350	8.89	1.125	28.58	2.405	61.09
.171	4.34	.395	10.03	1.162	29.51		
.197	5.00	.401	10.19	1.182	30.02		

NOTES:

1. Dimensions are in inches.
2. Metric equivalents are given for general information only.
3. Unless otherwise specified, tolerance is $\pm .005$ (0.13 mm).
4. All dimensions are after plating.
5. If the jack passes the electrical continuity test using the test plug, this will be accepted as evidence that the jack meets the contact location requirements.
6. All undimensioned pictorial representations are for reference purposes only.
7. Switch shall be in accordance with MIL-PRF-8805/3, part number MS25089-4B.

FIGURE 1. Dimensions and configurations (M9177/5-1) – Continued.

MIL-DTL-9177/5D

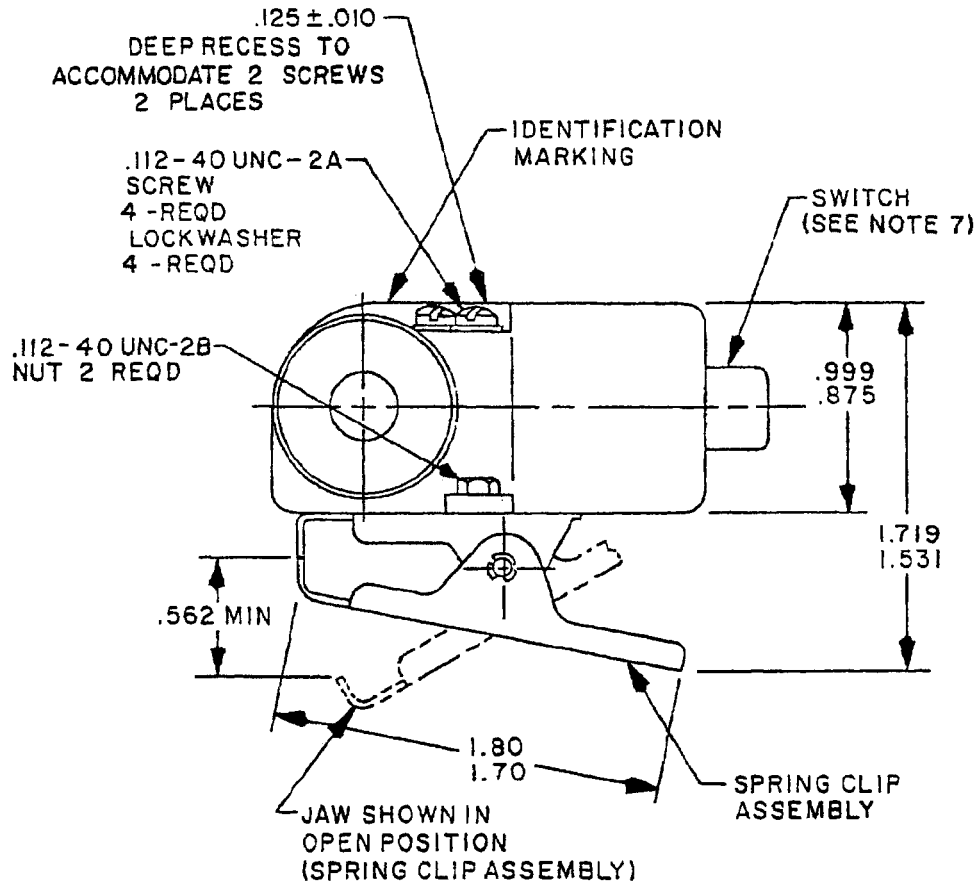

FIGURE 2. Dimensions and configurations (M9177/5-2).

MIL-DTL-9177/5D

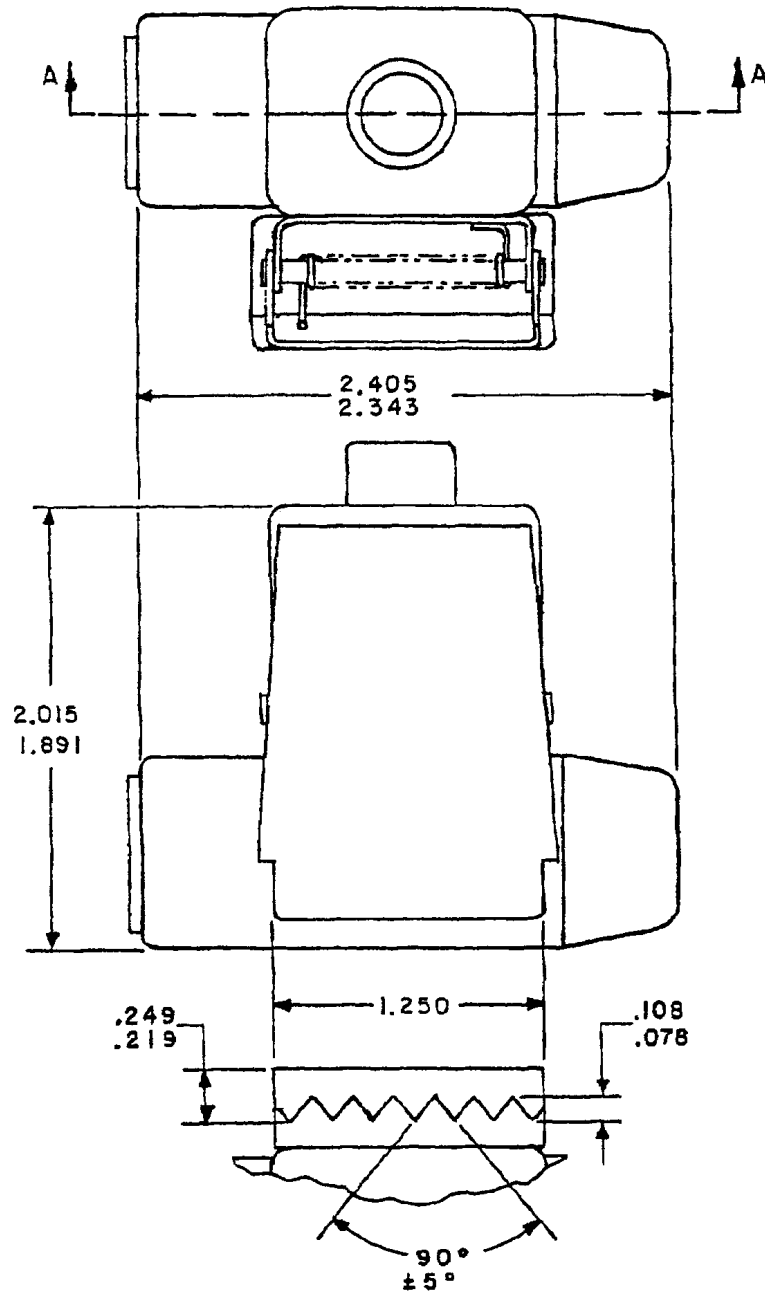

FIGURE 2. Dimensions and configurations (M9177/5-2) - Continued.

MIL-DTL-9177/5D

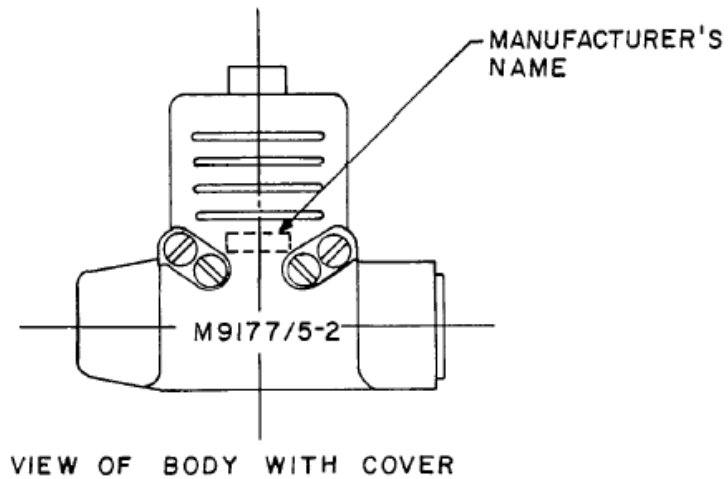
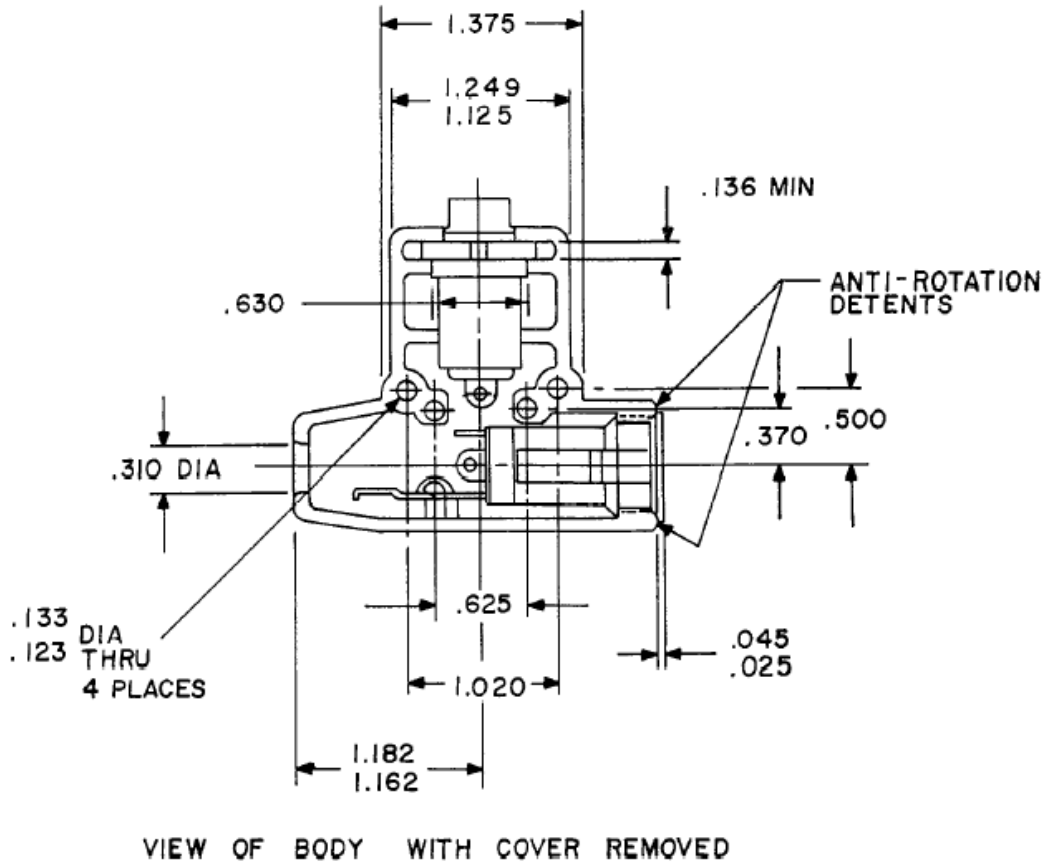

FIGURE 2. Dimensions and configurations (M9177/5-2) – Continued.

MIL-DTL-9177/5D

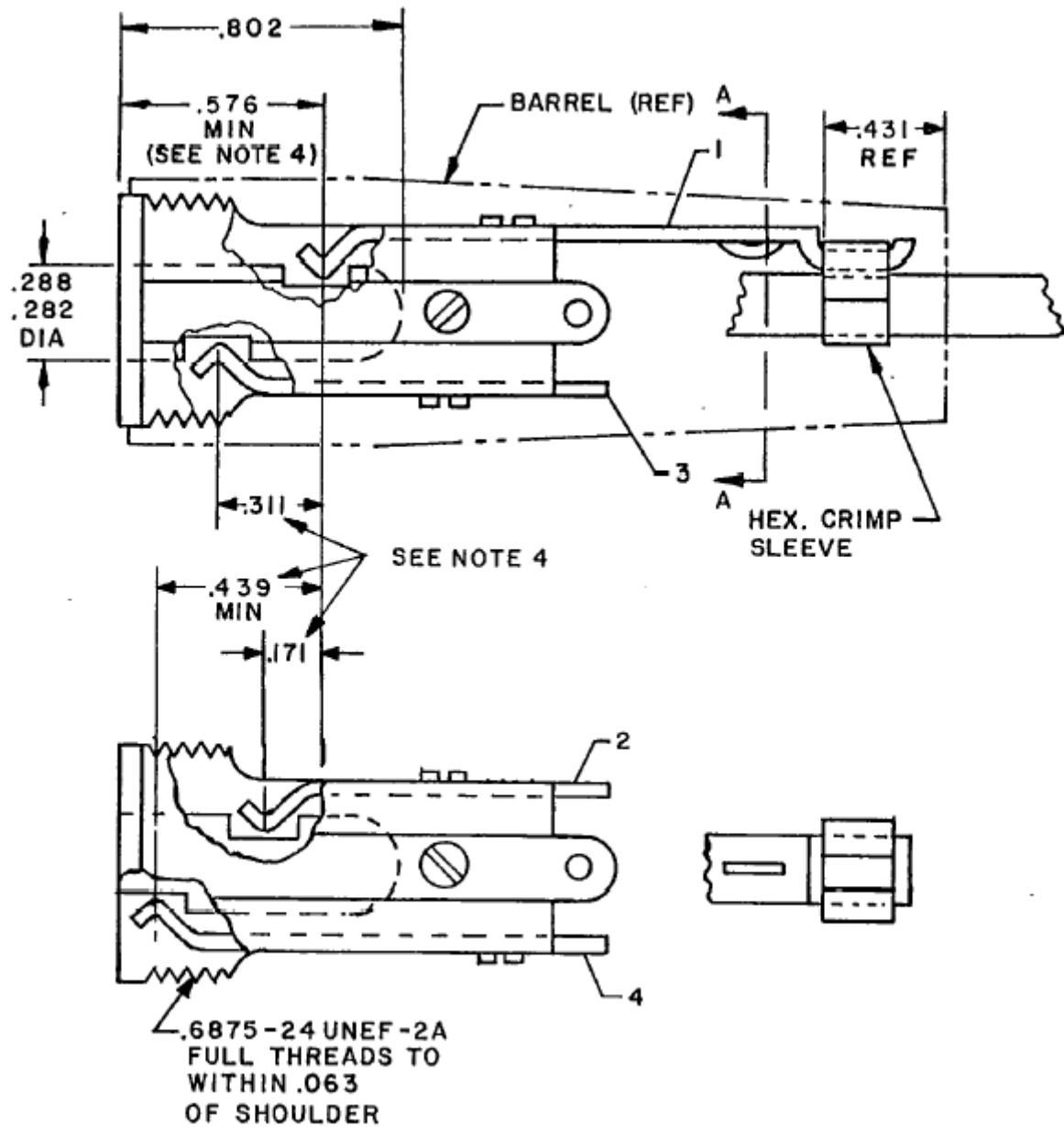
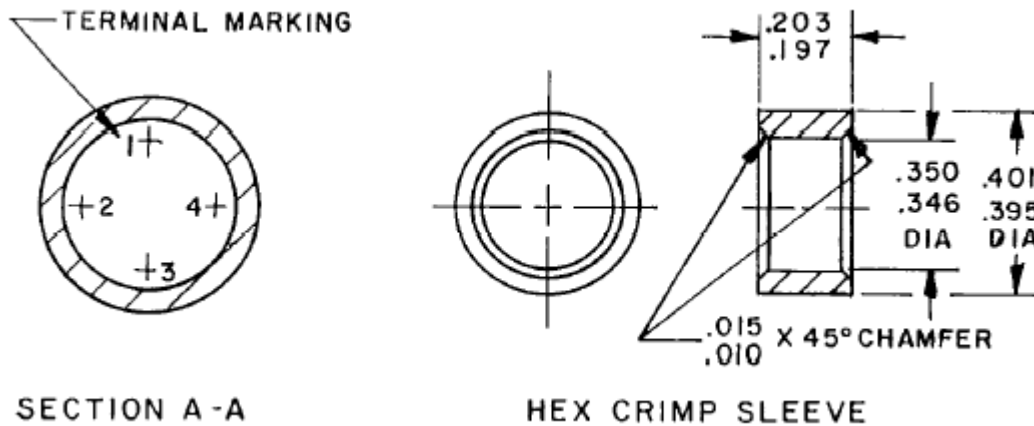

FIGURE 2. Dimensions and configurations (M9177/5-2) – Continued.

MIL-DTL-9177/5D



Inches	mm	Inches	mm	Inches	mm	Inches	mm
.010	0.25	.203	5.16	.431	10.95	1.249	31.72
.015	0.38	.219	5.56	.439	11.15	1.250	31.75
.025	0.64	.249	6.32	.562	14.27	1.531	38.89
.045	1.14	.282	7.16	.576	14.63	1.70	43.2
.078	1.98	.288	7.32	.630	16.00	1.719	43.66
.108	2.74	.310	7.87	.802	20.37	1.80	45.7
.123	3.12	.311	7.90	.844	21.44	1.891	48.03
.125	3.18	.312	7.92	.975	24.76	2.015	51.18
.133	3.38	.346	8.79	.999	25.37	2.343	59.51
.136	3.45	.350	8.89	1.125	28.58	2.405	61.09
.171	4.34	.395	10.03	1.162	29.51		
.197	5.00	.401	10.19	1.182	30.02		

NOTES:

1. Dimensions are in inches.
2. Metric equivalents are given for general information only.
3. Unless otherwise specified, tolerance is $\pm .005$ (0.13 mm).
4. All dimensions are after plating.
5. If the jack passes the electrical continuity test using the test plug, this will be accepted as evidence that the jack meets the contact location requirements.
6. All undimensioned pictorial representations are for reference purposes only.
7. Switch shall be in accordance with MIL-PRF-8805/3, part number MS25089-4B.

FIGURE 2. Dimensions and configurations (M9177/5-2) - Continued.

MIL-DTL-9177/5D

REQUIREMENTS:

Dimensions and configuration: See figures 1 and 2.

Switch: The switch shown on figures 1 and 2 shall be part number MS25089-4B in accordance with MIL-PRF-8805/3.

Crimp sleeve: Crimp sleeve requirement is applicable.

Tool data: Use M22520/5-01 hand tool with crimp die M22520/5-29, M22520/5-35, or M22520/5-55.

Spring attachment clip: Spring attachment clip requirement is applicable.

Static load: Static load test is applicable.

Insertion and withdrawal forces: The insertion and withdrawal forces shall be as specified:

Insertion force: 13 pounds maximum.

Withdrawal force: 6 pounds minimum, 10 pounds maximum.

Insertion and withdrawal force after spring life: 4.5 pounds minimum.

Frame strength: Frame strength test is applicable.

Body, insulation and shell: Materials shall have electrical and non-electrical properties appropriate for their intended use in electrical components. Optional materials are as follows:

Body and insulation:

- a. Glass-filled polycarbonates in accordance with ASTM-D3935
- b. Polystyrene in accordance with ASTM-D4549.
- c. Glass-filled nylon in accordance with ASTM-D4066.

Shell: Optional material is glass filled nylon in accordance with ASTM D4066.

Spring life: The spring life test is applicable.

Contact spring pressure: The contact spring pressure test is applicable.

Spring attachment clip life: Spring attachment clip life test is applicable.

Clip separation force prior to cycling:

Initiation of jaw separation: 2 pounds minimum, 4 pounds maximum.

Jaws open (full): 6 pounds maximum.

Anti-rotation detents: Anti-rotation requirement is applicable.

Cable retention: Cable retention test is applicable. The test cable shall be WF-14U. The force shall be 30 pounds minimum.

Changes from previous issue. Marginal notations are not used in this revision to identify changes with respect to the previous issue due to the extent of the changes.

MIL-DTL-9177/5D

Referenced documents. In addition to MIL-DTL-9177, this document references the following:

ASTM-D4549
ASTM-D4066
ASTM-D3935
MIL-PRF-8805/3

CONCLUDING MATERIAL

Custodians:
Air Force – 85
DLA - CC

Preparing Activity:
DLA - CC

Review activities:
Air Force – 19

(Project 5935-2018-121)

NOTE: The activities listed above were interested in this document as of the date of this document. Since organizations and responsibilities can change, you should verify the currency of the information above using the ASSIST Online database at <https://assist.dla.mil/>.