

INCH-POUND
MIL-DTL-9129G
19 June 2014
SUPERSEDING
MIL-DTL-9129F
18 April 2008

DETAIL SPECIFICATION

DISCHARGERS, ELECTROSTATIC GENERAL SPECIFICATION FOR

This specification is approved for use by all Departments and Agencies of the Department of Defense.

1. SCOPE

1.1 Scope. This specification covers the general requirements for aircraft electrostatic dischargers used to reduce radio frequency electromagnetic interference associated with the discharge of aircraft electrostatic charges.

1.2 Part or Identifying Number (PIN). The PIN will consist of the following:

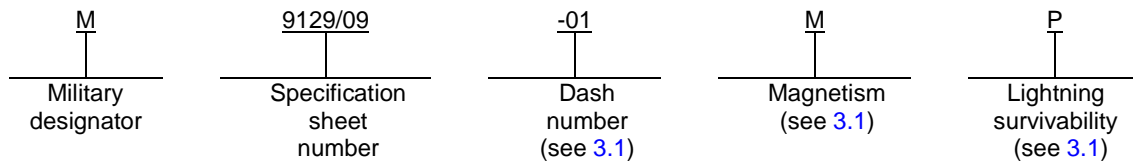

2. APPLICABLE DOCUMENTS

2.1 General. The documents listed in this section are specified in sections 3, 4 or 5 of this specification. This section does not include documents cited in other sections of this specification or recommended for additional information or as examples. While every effort has been made to ensure the completeness of this list, document users are cautioned that they must meet all specified requirements of documents cited in sections 3, 4 or 5 of this specification, whether or not they are listed.

2.2 Government documents.

2.2.1 Specifications, standards, and handbooks. The following specifications, standards, and handbooks form a part of this document to the extent specified herein. Unless otherwise specified, the issues of these documents are those cited in the solicitation or contract (see 6.2).

FEDERAL STANDARDS

FED-STD-H28 - Screw-Thread Standards for Federal Services.

Comments, suggestions, or questions on this document should be addressed to: DLA Land and Maritime, ATTN: DLA Land and Maritime-VAT, Post Office Box 3990, Columbus, Ohio 43218-3990 or by email to CircuitProtect@dla.mil. Since contact information can change, you may want to verify the currency of this address information using the ASSIST Online database at <https://assist.dla.mil/>.

MIL-DTL-9129G

DEPARTMENT OF DEFENSE SPECIFICATIONS

- [MIL-DTL-5624](#) - Turbine Fuel, Aviation, Grades JP-4 and JP-5.
- [MIL-PRF-87257](#) - Hydraulic Fluid, Fire Resistant; Low Temperature, Synthetic Hydrocarbon Base, Aircraft and Missile.

DEPARTMENT OF DEFENSE STANDARDS

- [MIL-STD-202](#) - Test Methods for Electronic and Electrical Component Parts.
- [MIL-STD-889](#) - Dissimilar Metals.
- [MIL-STD-1285](#) - Marking of Electrical and Electronic Parts.

(Copies of these documents are available online at <http://quicksearch.dla.mil> or <https://assist.dla.mil> or from DLA Document Services, Building 4/D, 700 Robbins Avenue, Philadelphia, PA 19111-5094).

2.2.2 Other Government documents, drawings, and publications. The following other Government documents, drawings, and publications form a part of this document to the extent specified herein. Unless otherwise specified, the issues are those cited in the solicitation or contract.

DRAWINGS

AIR FORCE

- [7136810](#) - Tester Assembly, Static Discharger

NAVY

- [NAVAIR 01-S3B-2-3-14-1](#) - Testing and Troubleshooting, Avionic Systems, Non-acoustical Sensors, Electronic Countermeasures, Navigation, Automated Flight Control, and Communications, S3B Aircraft Organizational Maintenance.

(Copies of the specifications, standards, and drawings required by contractors in connection with specific acquisition functions should be obtained from the contracting activity or as directed by the contracting activity.)

2.3 Non-Government publications. The following documents form a part of this document to the extent specified herein. Unless otherwise specified, the issues of these documents are those cited in the solicitation or contract (see 6.2).

AMERICAN SOCIETY FOR TESTING AND MATERIALS (ASTM)

- [ASTM-D910](#) - Gasolines, Aviation.

(Copies of these documents are available online at <http://www.astm.org> or from the American Society for Testing Materials, 100 Barr Harbor Drive, West Conshohocken. PA 19428-2951).

INTERNATIONAL ORGANIZATION FOR STANDARDS (ISO)

- [ISO 10012](#) - Measurement Management Systems - Requirements for Measurement Processes and Measuring Equipment.
- [ISO/IEC 17025](#) - General Requirements for the Competence of Testing and Calibration Laboratories.

(Copies of this document is available online at <http://www.iso.org/iso/home.html> or from the American National Standards Institute (ANSI), 1899 L Street, NW, 11th Floor, Washington, DC 20036-3801).

MIL-DTL-9129G

RADIO TECHNICAL COMMISSION FOR AERONAUTICS

[RTCA DO-160G](#) - Environmental Conditions and Test Procedures for Airborne Equipment.

(Copies of this document are available online at <http://www.rtca.org/> or from the Radio Technical Commission for Aeronautics, RTCA, Inc., 1828 L Street, NW, Suite 805, Washington, DC 20036, Tel: 202-833-9339, Fax: 202-833-9434).

SOCIETY OF AUTOMOTIVE ENGINEERS

[SAE AMS 1435](#) - Fluid, Generic, Deicing/Anti-Icing Runways and Taxiways.

(Copies of these documents are available online at <http://www.sae.org/> or from the Society of Automotive Engineers, 400 Commonwealth Drive, Warrendale, PA 15096-0001.)

2.4 Order of precedence. Unless otherwise noted herein or in the contract, in the event of a conflict between the text of this document and the references cited herein (except for related specification sheets), the text of this document takes precedence. Nothing in this document, however, supersedes applicable laws and regulations unless a specific exemption has been obtained.

3. REQUIREMENTS

3.1 Specification sheets. The individual item requirements shall be as specified herein and in accordance with the applicable specification sheets. In the event of any conflict between requirements of this specification and the specification sheets, the latter shall govern.

3.2 First article inspection. When specified, dischargers furnished under this specification shall be a product which has been tested and passed all applicable inspections specified in 4.4.

3.2.1 Information to be furnished with sample. The applicable information, outlined in 6.3, shall be furnished with the sample together with any other pertinent information as required by the Government.

3.3 Selection of specifications and standards. Specifications and standards for necessary items not specified herein shall be selected to meet the requirements of this specification. Commercial items having suitable properties may be used where no military standard parts exist for the same purpose.

3.4 Materials. Materials shall be as specified herein and the applicable specification sheet (see 3.1). Materials that are not specifically designated shall be inherently fungus resistant and possess such other overall characteristics as to provide for the furnished discharger to meet the requirements of this specification. Acceptance or approval of any constituent material shall not be construed as a guarantee of the acceptance of the finished product.

3.4.1 Metals. All metals used in the construction of the dischargers covered by this specification shall be corrosion resistant or protectively treated to resist corrosion in consonance with the performance requirements specified herein. When dissimilar metals are used in contact with each other, protection against electrolysis and corrosion shall be provided. Metal plating or metal spraying of dissimilar base metals to provide similar or suitable abutting surfaces is permitted. Dissimilar metals are defined in [MIL-STD-889](#).

3.4.2 Pure tin: The use of pure tin, as an underplate or final finish, is prohibited both internally and externally. Tin content of discharger components and solder shall not exceed 97 percent, by mass. Tin shall be alloyed with a minimum of 3 percent lead, by mass (see 6.5).

3.4.3 Nonmetallic materials. Nonmetallic materials and coatings shall not crack, chip, or otherwise deteriorate under temperature extremes, vibration, shock, and moisture conditions. Current carrying, nonmetallic materials shall provide permanent conductivity to the degree that will assure that the complete discharger meets the requirements of this specification.

3.5 Design and construction. Dischargers covered by this specification shall be of the design, construction, and physical dimensions specified herein and in the individual specification sheet (see 3.1).

3.5.1 Mounting. The type of mounting shall be as specified in the individual specification sheet (see 3.1).

MIL-DTL-9129G

3.5.1.1 Adhesives. Dischargers depending upon adhesives for attachment to the aircraft shall be so designed that the tip or body assemblies may be replaced without detachment or replacement of the mounting bracket or base.

3.5.2 Screw threads. Screw threads on removable parts shall be in accordance with [FED-STD-H28](#).

3.6 Performance. Unless otherwise specified (see [3.1](#)), static dischargers shall meet the following performance requirements.

3.6.1 Discharge current. Unless otherwise specified (see [3.1](#)), the discharge current shall be not less than 10 microamperes at a potential difference of 40 kV, applied across 6 inch spacing between the discharger tip and the grounded plate as in [figure 1](#). (see [4.6.2.1](#))

3.6.2 Radio frequency discharge noise. Unless otherwise specified (see [3.1](#)), the radio frequency total noise voltage (root mean square (rms) value of radio frequency generated and coupled by a discharger while it is discharging current at a rate of 50 microamperes shall be a minimum of either 40 dB (for trailing edge types) or 30 dB (for wing tip types) below the simulated trailing edge when measured in accordance with paragraph [4.6.2.2](#).

3.6.2.1 Noise voltage peaks. Any peaks of noise voltage at discrete frequencies within the passband shall not exceed the mean noise voltage by more than 20 dB, nor shall this level be permitted to occupy more than 10 percent of total passband width.

3.6.3 Continuous discharge. Continuous discharge capability shall be a minimum of 50 microamperes for a period of not less than 24 hours without material breakdown or other damage, and shall be capable of meeting the discharge current, radio frequency noise and direct current resistance requirements subsequent to the continuous discharge test (see [3.6.1](#), [3.6.2](#), [3.6.6](#) and [4.6.2.3](#)).

3.6.4 Power Dissipation (see [3.1](#)). The discharger shall withstand a continuous power of 5 watts for a period of 15 seconds without excessive heating (refer to [figure 2](#) for applied current requirement). The discharger shall be considered to have failed if:

- a. The post test discharger resistance exceeds the limits specified in [3.6.6](#).
- b. The temperature rise of the discharger during the 15 second application of power exceeds 25°C.
- c. The current flow, as indicated by the oscilloscope in [figure 4](#), shows irregularities of "noise", other than that directly due to power supply output voltage ripple.
- d. The post test RF discharge noise exceeds the limits specified in [3.6.2](#).

3.6.5 Electrical flashover. The discharger resistance shall remain within specified resistance limits when tested in accordance with [4.6.3](#). The dischargers shall be capable of meeting the discharge current and radio frequency discharge noise requirements subsequent to the flashover test (see [3.6.1](#) and [3.6.2](#)).

3.6.6 Direct current resistance. The resistance of dischargers measured from discharge points to discharger mounting base shall be at 25°C (see [4.6.4](#)):

- a. Trailing edge mounted = 6 to 200 megohms.
- b. Tip mounted = 6 to 120 megohms.
- c. Resistance shall be measured with a 500 volt minimum megohmmeter.

3.6.6.1 Resistance (-60°C to +45°C). The resistance of dischargers shall remain within specified limits when measured at the extreme temperatures of -60°C and +45°C, compared to the resistance measured at 25°C (see [4.6.4](#)).

MIL-DTL-9129G

3.6.7 Lightning transfer. Dischargers are to be tested for lightning transfer characteristics between the discharger holder section and a simulated aircraft skin (see 4.6.5). RTCA/DO-160G Section 23, zone 2A will be used. The current will be passed through the discharger holder and into the simulated skin. After the passing of the above current, the discharger and holder assembly (if applicable) shall remain intact (see 4.6.5).

3.6.8 Vibration. Dischargers shall be capable of withstanding high frequency vibration without physical damage when tested as specified in 4.6.6.

3.6.9 Shock. Dischargers shall be designed and constructed to withstand specified shock load with no physical damage (see 4.6.7).

3.6.10 Solvent resistance. Dischargers shall show no signs of deterioration from solvent materials when tested as specified in 4.6.8.

3.6.11 Thermal shock. Temperature extremes specified in 4.6.9 shall not result in any damage, or alter the function or operation of any of the dischargers covered by this specification.

3.6.12 Salt atmosphere (corrosion). There shall be no evidence of excessive corrosion. Excessive corrosion is defined as that which interferes with the electrical or mechanical performance, or in the case of plated metals, corrosion which has passed through the plating and attacked the base metal. There shall be no warping, cracking, or other electrical or mechanical damage to the discharger (see 4.6.10).

3.6.13 Tension. All dischargers shall be so designed and constructed that their attachment into end components and onward into the mounting adapter (if any) shall withstand without damage a load applied as in 4.6.11. The discharger tip assembly shall similarly withstand a load of 10 pounds.

3.6.14 Sand and dust. When tested as specified in 4.6.12, dischargers shall be capable of withstanding sand and dust. There shall be no evidence of excessive abrasion that will interfere with the electrical or mechanical performance. There shall be no evidence of warping, cracking or other electrical or mechanical damage to the discharger (see 4.6.12).

3.6.15 Magnetism. In order for a discharger to qualify as a non-magnetic discharger, it must pass the test specified in 4.6.13.

3.6.16 Lightning survivability. In order to qualify as a lightning survivable discharger a unit must be tested per RTCA/DO-160G Section 23, zone 1A. Following completion of this test, the unit shall remain intact and shall meet the requirements of paragraphs 3.6.1, 3.6.2 and 3.6.6 (see 4.6.14).

3.7 Marking. Dischargers shall be permanently and legibly marked in accordance with MIL-STD-1285 and shall include the following information:

- a. Military part number.
- b. Manufacturer's part number and name is optional.
- c. Manufacturer's CAGE.
- d. Date code. The date code shall consist of "MFD", followed by a four-digit number in which the first two digits indicate the month and the last two digits indicate the year; i.e., "MFD-0500" indicates a unit manufactured in May of 2000.

3.8 Recycled, recovered, or environmentally preferable, or biobased materials. Recycled, recovered, environmentally preferable, or biobased materials should be used to the maximum extent possible, provided that the material meets or exceeds the operational and maintenance requirements, and promotes economically advantageous life cycle costs.

MIL-DTL-9129G

3.9 Workmanship. Dischargers shall be processed in such a manner as to be uniform in quality and shall be free from cracked, loose, or displaced parts, sharp edges, burrs, and other defects that will affect life, serviceability, or ability to meet the requirements of this specification.

VERIFICATION

4.1 Classification of inspections. The inspection requirements specified herein are classified as follows:

- a. First article inspection (see 4.4).
- b. Conformance inspection (see 4.5).

4.2 Test equipment and inspection facilities. The manufacturer shall establish and maintain a calibration system in accordance with [ISO/IEC 17025](#), [ISO 10012](#), or equivalent system as approved by the qualifying activity.

4.2.1 Mounting for test. Unless otherwise specified, the dischargers shall be mounted by the normal method, including the use of appropriate adhesives if applicable. Non-integral dischargers shall be tested with all applicable holders as specified in the specification sheets.

4.3 Inspection conditions. Unless otherwise specified herein, all inspections shall be performed in accordance with the test conditions specified in the "GENERAL REQUIREMENTS" of [MIL-STD-202](#).

4.4 First article inspection. First article inspection shall be performed by the manufacturer on sample units produced with equipment and procedures normally used in production, after award of the contract and prior to production, at a laboratory acceptable to the government (see 6.3).

4.4.1 Sample. Unless otherwise specified, 10 dischargers (see 3.1) shall be submitted for first article inspection. The sample shall be taken from a production run or shall be produced with equipment and procedures normally used in production. An additional two samples shall be required for dischargers being inspected to include the magnetism characteristic (see 3.6.15). An additional two samples shall be required for dischargers being inspected to include the lightning survivability characteristic (see 3.6.16).

4.4.2 Inspection routine. The sample units shall be subjected to the first article inspection specified in [table I](#) in the order shown. All sample units shall be appropriately coded or otherwise identified to indicate the tests to which each was subjected. All units shall be subjected to the group I inspection. After group I inspection, the sample units shall be divided and subjected to inspection specified in [table I](#). Non-integral dischargers that can interface with multiple holders shall be subject to the applicable tests in [table I](#) with only one of those holders. After completion of the tests in [table I](#) with one of the holders, dischargers shall be tested for vibration, lightning transfer and salt spray with each additional holder listed in the specification sheets. There shall be two sample units subjected to vibration, lightning transfer and salt spray, tested sequentially in that order.

4.4.3 Failure. Failure in any of the applicable inspection elements shall be cause for refusal to accept the first article inspection.

4.4.4 Test verification and samples. The manufacturer shall provide verification to the procuring activity that the first article inspection has been performed on the samples supplied to the requirements of this specification. The tested dischargers shall be identified to indicate the applicable tests to which each has been subjected. The Government reserves the right to require the manufacturer to furnish additional untested samples.

4.5 Conformance inspection.

4.5.1 Inspection of product for delivery. Inspection of product for delivery shall consist of Group A and Group B inspections.

4.5.1.1 Inspection lot. An inspection lot shall consist of all dischargers of the same type produced under essentially the same conditions, and offered for inspection at one time. The lot may include the entire contract quantity, or it may be the production of any convenient time period at the choice of the Government inspector.

MIL-DTL-9129G

4.5.1.2 Group A inspection. Group A inspection shall consist of the inspections specified in [table III](#), in the order shown.

4.5.1.2.1 Sampling plan. Group A inspection shall be on an inspection lot basis. Samples shall be selected in accordance with [table II](#), based on the inspection lot. If there are one or more failures, the inspection lot shall be considered to have failed.

TABLE I First article inspection.

Inspection	Requirement paragraph	Test method paragraph
<u>Group I (all sample units)</u>		
Visual and mechanical inspection	3.1, 3.4, 3.5, 3.7 and 3.8	4.6.1
Direct current resistance	3.6.6	4.6.4
Discharge current	3.6.1	4.6.2.1
Radio frequency discharge noise	3.6.2	4.6.2.2
<u>Group II (2 sample units)</u>		
Continuous discharge	3.6.3	4.6.2.3
Discharge current	3.6.1	4.6.2.1
Radio frequency discharge noise	3.6.2	4.6.2.2
<u>Group III (2 sample units)</u>		
Electrical flashover	3.6.5	4.6.3
Discharge current	3.6.1	4.6.2.1
Radio frequency discharge noise	3.6.2	4.6.2.2
Lightning transfer	3.6.7	4.6.5
<u>Group IV (2 sample units)</u>		
Direct current resistance	3.6.6	4.6.4
Power dissipation	3.6.4	4.6.2.4
Radio frequency discharge noise	3.6.2	4.6.2.2
<u>Group V (2 sample units)</u>		
Vibration	3.6.8	4.6.6
Shock	3.6.9	4.6.7
Discharge current	3.6.1	4.6.2.1
Radio frequency discharge noise	3.6.2	4.6.2.2
Salt spray	3.6.12	4.6.10
<u>Group VI (2 sample units)</u>		
Solvent resistance	3.6.10	4.6.8
Thermal shock	3.6.11	4.6.9
Discharge current	3.6.1	4.6.2.1
Radio frequency discharge noise	3.6.2	4.6.2.2
Tension	3.6.13	4.6.11
Sand and dust	3.6.14	4.6.12
<u>Group VII (2 sample units)</u>		
Lightning survivability	3.6.16	4.6.14
Discharge current	3.6.1	4.6.2.1
Radio frequency discharge noise	3.6.2	4.6.2.2
<u>Group VIII (2 sample units)</u>		
Magnetism	3.6.15	4.6.13

MIL-DTL-9129G

TABLE II. Group A, zero defect sampling plan.

Lot size	Sample size
1 - 13	100 percent
14 - 150	13
151 - 280	20
281 - 500	29
501 - 1,200	34
1,201 - 3,200	42
3,201 - 10,000	50
10,001 - 35,000	60
35,001 - 150,000	74
150,001 - 500,000	90
500,001 and up	102

4.5.1.2.2 Rejected lots. If an inspection lot is rejected, the manufacturer may rework it to correct the defects, or screen out the defective units, and resubmit for inspection. Such lots shall be kept separate from new lots and shall be clearly identified as reinspected lots. If one or more defects are found in this second sample, the lot shall be rejected and shall not be supplied to this specification.

TABLE III Group A inspection.

Inspection	Requirement paragraph	Test method paragraph
Visual and mechanical inspection	3.1, 3.4, 3.5, 3.7 and 3.8	4.6.1
Direct current resistance	3.6.6	4.6.4
discharge current	3.6.1	4.6.2.1
Radio frequency discharge noise	3.6.2	4.6.2.2

4.5.1.3 Group B inspection. Group B inspection shall consist of the tests specified in [table IV](#), in the order shown.

4.5.1.3.1 Sampling plan. Group B inspection shall not be required for contracts or orders of less than 100 units. Dischargers shall be selected at random from sample units which passed group A inspection. The number of sample units required shall be as noted in [table IV](#). Failure of any group B tests shall constitute rejection of the lot.

4.5.1.3.2 Rejected lots. If an inspection lot is rejected, the manufacturer may rework it to correct the defects, or screen out the defective units, and resubmit for reinspection. Resubmitted lots shall be inspected using tightened inspection. Such lots shall be separate from new lots, and shall be clearly identified as reinspected lots.

4.5.1.3.3 Disposition of sample units. Sample units which have passed group B inspection may be delivered on the contract or purchase order, if the represented lot is accepted and adhesive mountings were not used during the tests.

TABLE IV. Group B inspection.

Inspection	Requirement paragraph	Test method paragraph
(4 sample units)		
Direct current resistance	3.6.6	4.6.4
Power dissipation	3.6.4	4.6.2.4
Discharge current	3.6.1	4.6.2.1
Radio frequency discharge noise	3.6.2	4.6.2.2

MIL-DTL-9129G

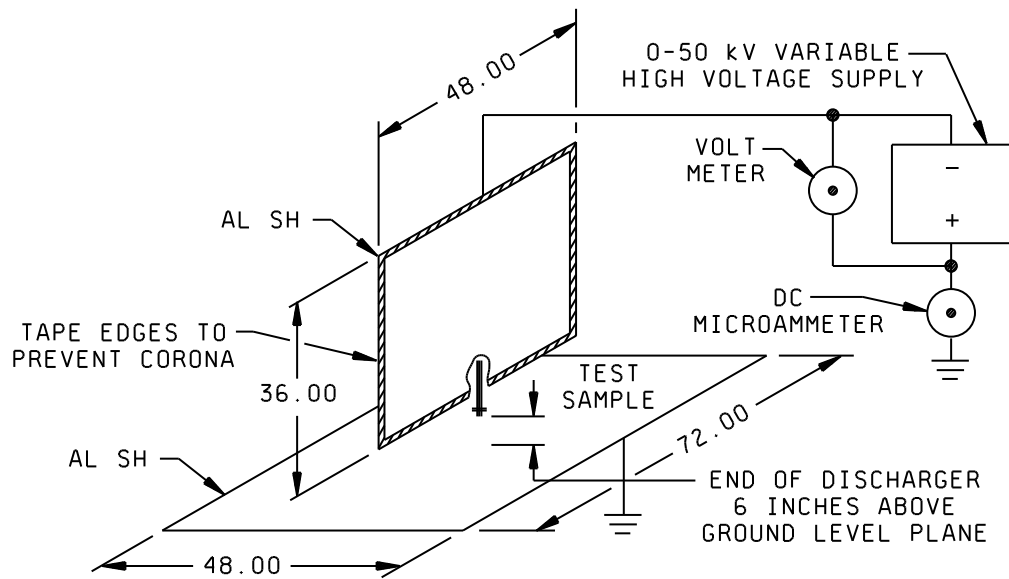

NOTES:

1. Dimensions are in inches.
2. Metric equivalents are given for information only.
3. Unless otherwise specified, the tolerance is $\pm .12$ (3.0 mm).

FIGURE 1. Discharge current test configuration.

MIL-DTL-9129G

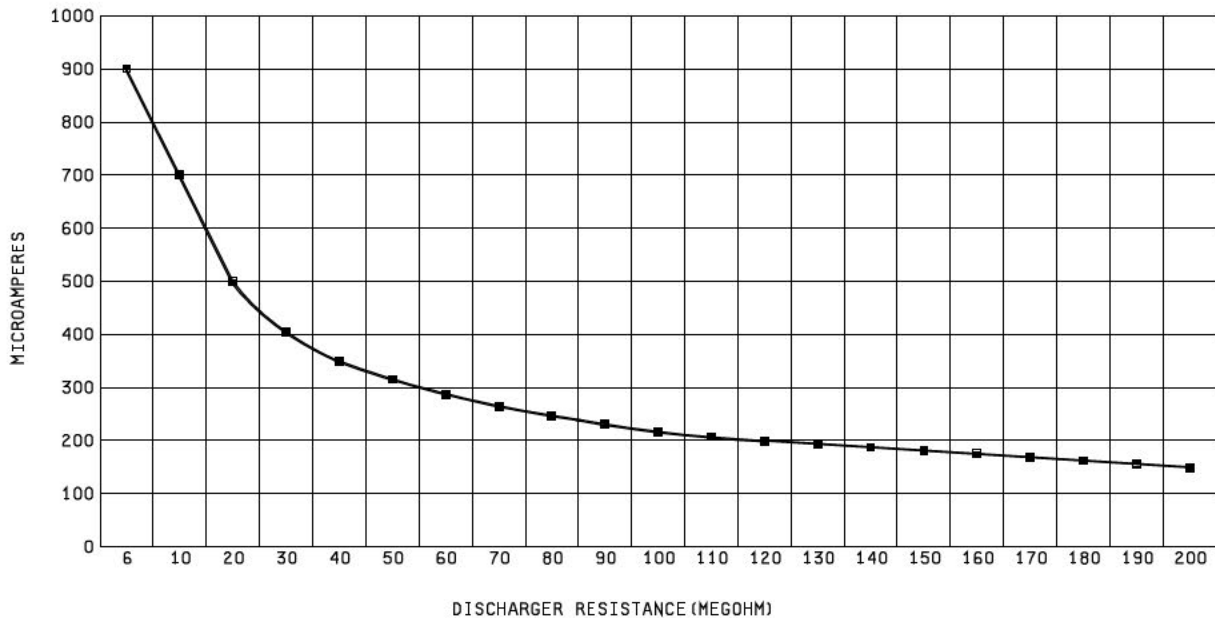
STATIC DISCHARGERS
5 WATT POWER DISSIPATION CURVEFIGURE 2. Power Dissipation test.4.6 Methods of inspection and test.

4.6.1 Visual and mechanical inspection. Dischargers shall be inspected to verify that the physical dimensions, materials, design, construction, marking, and workmanship are in accordance with the applicable requirements.

4.6.2 Discharge current measurement and test.

4.6.2.1 Discharge current (see 3.6.1). Discharge current, voltage and spacing between the discharge points shall be measured, and recorded using the test configuration outlined in figure 1. Any leakage current in the test circuit with the discharger removed shall be subtracted from the specified test current when increasing the test voltage to the specified maximum. Ambient relative humidity and temperature shall be within the ranges of 40 to 60 percent and 16°C to 27°C, respectively.

4.6.2.2 Radio frequency discharge noise (see 3.6.2). Radio frequency discharge noise shall be measured using the test configuration outlined in figure 3. The tester shall be in accordance with Air Force Drawing 7136810 or equivalent tester assembly. The rms voltmeter shall be a "J" Fluke Model 910A, Hewlett Packard Model 3400A, or equivalent. The amplifier, Tektronix type 1121 or equivalent, shall have an input impedance in excess of 1 megohm and a flat frequency response from 5 Hz to 17 MHz. The tester shall be calibrated using a 16 gauge solid metal wire 7 inches long with a radius of curvature on the discharge end equal to one half of the wire diameter. The rms noise voltage generated with the wire discharging 50 μ A will be measured and recorded as the calibration standard. This calibration standard is being specified as being 10 dB below the noise similarly generated by a simulated trailing edge. The discharger will then be installed and its rms noise voltage generated at 50 μ A shall be recorded. The dB noise difference between the simulated trailing edge and discharger shall meet the requirements of paragraph 3.6.2. When testing the calibration standard on the discharger, the end of the standard or the discharge area (as applicable) will break the plane of the cone in figure 3.

MIL-DTL-9129G

4.6.2.3 Continuous discharge test (see 3.6.3). Dischargers shall be subjected to the specified discharge current and time period using the method outlined in figure 1 for applying the required current load. The distance between the test set electrode and the discharger points may be reduced for this test (if the discharge points do not physically contact the electrode) so that the required discharge current may be achieved without excessive voltage. A number of test sets may be operated in parallel with no more than one discharger in each test set, so long as the average recorded discharge current for each discharger is maintained at the required level. The discharger points shall be approximately centered with respect to the test set electrode face. Subsequent to continuous discharge tests, the dischargers shall be retested in accordance with 3.6.1, at the spacing previously recorded, and 3.6.2 for radio frequency discharge noise. Ambient relative humidity and temperature during the test period shall be 40 to 60 percent and 16°C to 27°C, respectively.

4.6.2.4 Power dissipation test (see 3.6.4). Dischargers shall be subjected to the specified continuous power (see figure 2) using the method outlined in figure 4.

4.6.3 Electrical flashover test (see 3.6.5). The direct current resistance of the discharger shall be measured before and after being subjected to five 200 joule electrical impulses. The resistance of the discharger after the impulses shall be within the specified tolerance, and the discharge current and radio frequency discharge noise (see 3.6.1 and 3.6.2) shall remain within the required limits. The test configuration shall be in accordance with that shown on figure 5.

4.6.4 Direct current resistance test (see 3.6.6). The direct current resistance shall be measured from the discharge area to the discharger mounting base after a stabilization/soak period of not less than 10 minutes at the specified temperature.

4.6.5 Lightning transfer (see 3.7). The discharger assembly shall be tested in accordance with zone 2A, current components B, C and D of RTCA/DO-160G, section 23, using a dwell time of 125 ms \pm 25 ms for the continuing current. The following details shall apply:

- a. Integral dischargers shall be mounted on an aluminum panel .08 inches thick, 12 by 12 inches with the appropriate mounting method procedure.
- b. Non-integral dischargers shall be mounted on their mating holder and the holder shall be attached to an aluminum panel .08 inches thick, 12 by 12 with the appropriate mounting method procedure. Measure the bond resistance between the discharger base and grounded aluminum panel. The resistance shall be 2.5 milliohms maximum.
- c. Position the probe within ½ inch of the discharger base.
- d. Apply the current components in the order of D, B, C. It may be required to reposition the probe after application of any one component in order to complete the remainder.
- e. Two dischargers shall be tested as above. The dischargers and holder assemblies (if applicable) shall remain intact. The resistance of the discharger shall remain within the specified limits.

4.6.6 Vibration (see 3.6.8). The discharger shall be tested in accordance with method 204 of MIL-STD-202. Discharger resistance shall remain within the specified limits. The following details shall apply:

- a. All dischargers less than 300 knots:
 - (1) Mounting - Securely attached to a rigid fixture by normal mounting (see 4.2.1).
 - (2) Test condition - C.
 - (3) Inspection after test - Inspect for broken, cracked, or loosened components.
- b. All dischargers less than 600 knots:
 - (1) Mounting - Securely attached to a rigid fixture by normal mounting (see 4.2.1).

MIL-DTL-9129G

(2) Test condition - D.

(3) Inspection after test - Inspect for broken, cracked, or loosened components.

c. All dischargers greater than 600 knots:

(1) Mounting - Securely attached to a rigid fixture by normal mounting (see [4.2.1](#)).

(2) Test condition - E.

(3) Inspection after test - Inspect for broken, cracked, or loosened components.

4.6.7 Shock (see [3.6.9](#)). The discharger shall be tested in accordance with [method 213 of MIL-STD-202](#). Discharger resistance shall remain within the specified limits. The following details shall apply:

a. Mounting - Normal means (see [4.2.1](#)).

b. Referenced surfaces - No special requirements.

c. Test condition - I.

d. Inspection after test - Inspect for broken, cracked, or loosened components.

4.6.8 Solvent resistance test (see [3.6.10](#)). The discharger shall be submerged for a period of 1 hour, in each of the following materials:

a. Hydraulic fluid ([MIL-PRF-87257](#)).

b. Jet engine fuel ([MIL-DTL-5624](#)).

c. Gasoline ([ASTM-D910](#)).

d. Deicing fluid ([SAE AMS 1435](#)).

After each soaking period, the discharger shall be inspected for deterioration of nonmetallic components and coatings. On completion of test, the discharger shall be thoroughly dried and inspected for softening or hardening of nonmetallic components and coatings caused by the exposure. The discharger resistance shall remain within the specified limits.

4.6.9 Thermal shock (see [3.6.11](#)). The discharger shall be subjected to temperature cycling in accordance with [method 107 of MIL-STD-202](#). The following details shall apply:

a. Test Condition A for dischargers less than 500 knots and test condition B for dischargers greater than 600 knots.

b. Measurements - Flexible discharger shall be hand flexed after removal from cold chamber and inspected for breaks or cracks. After completion of test, the discharger shall be inspected for deterioration of material and other damage. The discharger resistance shall remain within the specified limits.

MIL-DTL-9129G

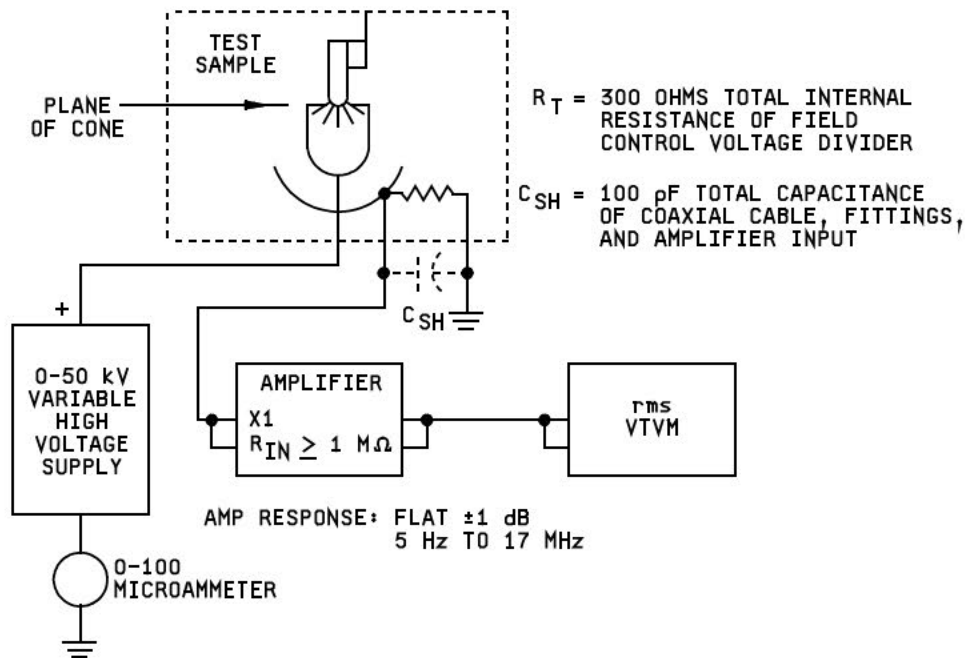
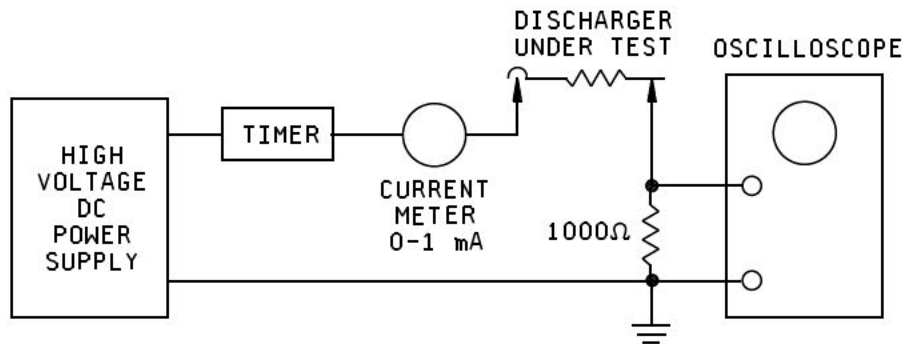
FIGURE 3. Radio frequency noise test configuration.

NOTES

1. Adjust timer for "ON" time of 15 seconds.
2. Adjust high voltage power supply to produce a continuous power of 5 watts (see figure 2).
3. Discharger connection will be at manufacturer's discretion.
- 4.

FIGURE 4. High current test configuration.

MIL-DTL-9129G

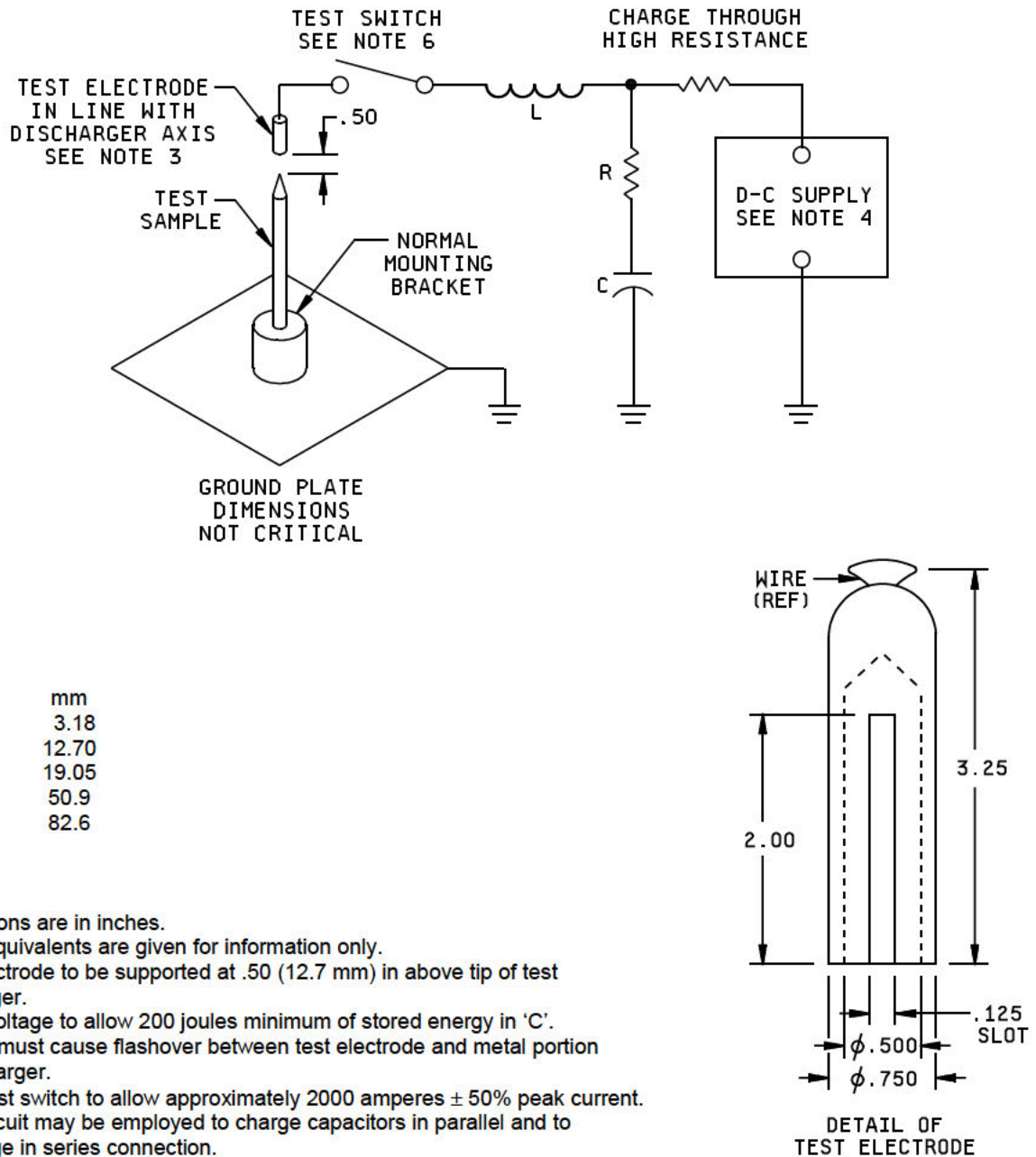

Inches	mm
.125	3.18
.500	12.70
.750	19.05
2.00	50.9
3.25	82.6

NOTES:

1. Dimensions are in inches.
2. Metric equivalents are given for information only.
3. Test electrode to be supported at .50 (12.7 mm) in above tip of test discharger.
4. Adjust voltage to allow 200 joules minimum of stored energy in 'C'.
5. Voltage must cause flashover between test electrode and metal portion of discharger.
6. Close test switch to allow approximately 2000 amperes \pm 50% peak current.
7. Marx circuit may be employed to charge capacitors in parallel and to discharge in series connection.
8. Unless otherwise specified, tolerances are \pm .005 (0.13 mm) for three place decimals and \pm .02 (0.51 mm) for two place decimals.

FIGURE 5. Electrical impulse flashover test configuration.

MIL-DTL-9129G

4.6.10 Salt atmosphere (corrosion) (see [3.6.12](#)). The discharger shall be tested in accordance with [method 101 of MIL-STD-202](#). The following details shall apply:

- a. 5-percent salt solution.
- b. Test condition - B.
- c. Following the drying period, the dischargers shall be subjected to 50 microamperes (50 μ A) for 1 hour.
- d. Following the test, dischargers shall be inspected for compliance with [3.6.6](#).

4.6.11 Tension test (see [3.6.13](#)). The discharger shall be attached to a metal plate by normal method and subjected to a load of 50 pounds applied along the longitudinal discharger axis between the outer discharger extremities and mounting plate. After test, the discharger shall be inspected for breaks, cracks, separations, or other damage of components or coatings, and separation from the mounting plate. The discharger resistance shall remain within the specified limits.

4.6.12 Sand and dust (see [3.6.14](#)). The discharger shall be tested in accordance with [method 110 of MIL-STD-202](#). The following details shall apply:

- a. Test condition A for dischargers less than 600 knots. For dischargers greater than 600 knots, test condition A shall apply except that the specified velocity shall be 2,500 \pm 500 F.P.M.
- b. Following completion, the test dischargers shall meet the minimum requirements of [3.6.1](#), [3.6.2](#), and [3.6.6](#).

4.6.13 Magnetism (see [3.1](#) and [3.6.15](#)). Dischargers shall be tested in accordance with [NAVAIR 01-S3B-2-3-14-1](#) section 7 or an equivalent test procedure.

4.6.14 Lightning survivability (see [3.1](#) and [3.6.16](#)). Dischargers shall be tested in accordance with zone 1A, current components A and B of [RTCA/DO-160G](#), section 23 as follows:

- a. Repeat the steps of paragraph [4.6.5](#), steps a through e using the current components A and B as stated above.
- b. Following completion of the test above, the discharger and holder assemblies (if applicable) shall be tested per paragraph [4.6.2.1](#) and [4.6.2.2](#) and remain within the required limits to be classified as a lightning survivable discharger. Further, the discharger resistance shall remain within the specified limits.

5. PACKAGING

5.1 Packaging. For acquisition purposes, the packaging requirements shall be as specified in the contract or order (see [6.2](#)). When packaging of materiel is to be performed by DoD or in-house contractor personnel, these personnel need to contact the responsible packaging activity to ascertain packaging requirements. Packaging requirements are maintained by the Inventory Control Point's packaging activities within the Military Service or Defense Agency, or within the military service's system commands. Packaging data retrieval is available from the managing Military Department's or Defense Agency's automated packaging files, CD-ROM products, or by contacting the responsible packaging activity.

MIL-DTL-9129G

6. NOTES

(This section contains information of a general or explanatory nature that may be helpful, but is not mandatory.)

6.1 Intended use.

6.1.1 Dischargers. Dischargers covered by this specification are for use in the reduction of aircraft precipitation static discharge interference to radio communications and navigational systems.

6.2 Ordering data. Acquisition documents should specify the following:

- a. Title, number, and date of this specification.
- b. Military part number (see 3.1).
- c. Title, number, and date of the applicable specification sheet (see 3.1).
- d. Packaging requirements (see 5.1).
- e. If special or other identification marking is required (see 5.1).

6.3 First article inspection. Information pertaining to first article inspection of products covered by this specification should be obtained from the acquiring activity for the specific contracts involved. Acquisition documents should specify the following:

- a. Title, number, and date of this specification.
- b. Military or commercial part number, as applicable.
- c. Samples, verification, and test routine, if other than specified (see 4.4.4).
- d. Design and construction (see 3.5).
- e. Performance requirements (see 3.1).

6.4 Warning. Potentially hazardous situations could develop in some of the test procedures specified in this specification. Precautions should therefore be taken to insure that test personnel are adequately protected and observe the necessary safety measures at all times.

6.5 Tin whisker growth. The use of alloys with tin content greater than 97 percent, by mass, may exhibit tin whisker growth problems after manufacture. Tin whiskers may occur anytime from a day to years after manufacture and can develop under typical operating conditions, on products that use such materials. Conformal coatings applied over top of a whisker-prone surface will not prevent the formation of tin whiskers. Alloys of 3 percent lead, by mass, have shown to inhibit the growth of tin whiskers. For additional information on this matter, refer to [ASTM-B545](#) (Standard Specification for Electrodeposited Coatings of Tin).

6.6 Environmentally preferable material. Environmentally preferable materials should be used to the maximum extent possible to meet the requirements of this specification. As of the dating of this document, the U.S. Environmentally Protection Agency (EPA) is focusing efforts on reducing 31 priority chemicals. The list of chemicals is available on their website at <http://www.epa.gov/osw/hazard/wastemin/priority.htm>. Included in the EPA list of 31 priority chemicals are cadmium, lead, and mercury. Use of the materials on the list should be minimized or eliminated unless needed to meet the requirements specified herein (see [Section 3](#)).

6.7 Subject (key word) listing.

Discharge current
Lightning survivability
Magnetism
Radio frequency discharge noise

MIL-DTL-9129G

6.8 Changes from previous issue. The margins of this specification are marked with vertical lines to indicate where changes from the previous issue were made. This was done as a convenience only and the Government assumes no liability whatsoever for any inaccuracies in these notations. Bidders and contractors are cautioned to evaluate the requirements of this document based on the entire content irrespective of the marginal notations and relationship to the last previous issue.

Custodians:

Army - CR
Navy - AS
Air Force - 85
DLA - CC

Preparing activity
DLA - CC

(Project 5920-2012-044)

Review activities:

Army - CE, MI
Navy - MC
Air Force - 19, 99

NOTE: the activities listed above were interested in this document as of the date of this document. Since organizations and responsibilities can change, you should verify the currency of the information above using the ASSIST Online database at <https://assist.dla.mil>.