

**INCH-POUND**  
MIL-DTL-9129E  
12 April 2001  
SUPERSEDING  
MIL-D-9129D  
30 September 1986

DETAIL SPECIFICATION  
DISCHARGERS, ELECTROSTATIC  
GENERAL SPECIFICATION FOR

This specification is approved for use by all Departments and Agencies of the Department of Defense.

1. SCOPE

1.1 Scope. This specification covers the general requirements for aircraft electrostatic dischargers used to reduce radio frequency electromagnetic interference associated with the discharge of aircraft electrostatic charges.

1.2 Military part number. The military part number is constructed as follows:

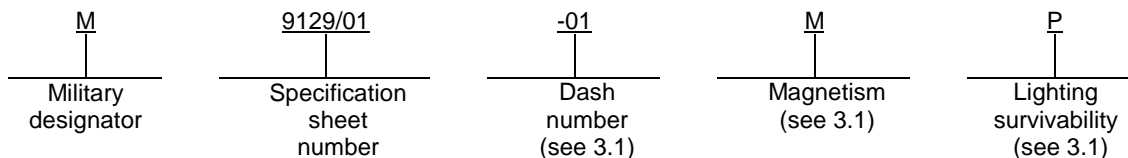

2. APPLICABLE DOCUMENTS

2.1 General. The documents listed in this section are specified in sections 3 and 4 of this specification. This section does not include documents cited in other sections of this specification or recommended for additional information or as examples. While every effort has been made to ensure the completeness of this list, document users are cautioned that they must meet all specified requirements documents cited in sections 3 and 4 of this specification, whether or not they are listed.

2.2 Government documents.

2.2.1 Specifications, standards, and handbooks. The following specifications, standards, and handbooks form a part of this document to the extent specified herein. Unless otherwise specified, the issues of these documents are those listed in the issue of the Department of Defense Index of Specifications and Standards (DoDISS) and supplement thereto, cited in the solicitation (see 6 2).

SPECIFICATIONS

DEPARTMENT OF DEFENSE

MIL-DTL-5624	-	Turbine Fuel, Aviation, Grades JP-4 and JP-5, and JP-5/JP-8 ST.
MIL-D-9129/9	-	Holder, Discharger, Electrostatic.

Beneficial comments (recommendations, additions, deletions) and any pertinent data which may be of use in improving this document should be addressed to: (ex. Defense Supply Center, Columbus, ATTN: DSCC/VAT, Post Office Box 3990, Columbus, OH 43216-5000), by using the Standardization Document Improvement Proposal (DD Form 1426) appearing at the end of this document or by letter.

## MIL-DTL-9129E

## STANDARDS

## FEDERAL

FED-STD-H28 - Screw-Thread Standards for Federal Services.

## DEPARTMENT OF DEFENSE

MIL-STD-202 - Test Methods for Electronic and Electrical Component Parts.

MIL-STD-889 - Dissimilar Metals.

MIL-STD-1285 - Marking of Electrical and Electronic Parts.

(Unless otherwise indicated, copies of the above specifications, standards, and handbooks are available from the Document Automation and Production Service, Building 4D (DPM-DODSSP), 700 Robins Avenue, Philadelphia, PA 19111-5094.)

2.2.2 Other Government documents, drawings, and publications. The following other Government documents, drawings, and publications form a part of this document to the extent specified herein. Unless otherwise specified, the issues are those cited in the solicitation.

## DRAWINGS

## AIR FORCE

7136810 - Tester Assembly, Static Discharger

## NAVY

NAVAIR 01-S3B-2-3-14-1 - Testing and Troubleshooting, Avionic Systems, Non-acoustical Sensors, Electronic Countermeasures, Navigation, Automated Flight Control, and Communications, S3B Aircraft Organizational Maintenance.

(Copies of the specifications, standards, and drawings required by contractors in connection with specific acquisition functions should be obtained from the contracting activity or as directed by the contracting activity.)

2.3 Non-Government publications. The following documents form a part of this document to the extent specified herein. Unless otherwise specified, the issues of the documents that are DoD adopted are those listed in the issue of the DoDISS cited in the solicitation. Unless otherwise specified, the issues of documents not listed in the DoDISS are the issues of the documents cited in the solicitation (see 6.2).

## AMERICAN NATIONAL STANDARDS INSTITUTE (ANSI)

ANSI Z540 - General Requirements for Calibration Laboratories and Measuring and Test Equipment.

(Applications for copies should be addressed to American National Standards Institute, 11 West 42nd Street, New York NY 10036.)

## AMERICAN SOCIETY FOR TESTING AND MATERIALS (ASTM)

ASTM D910 - Standard Specification for Aviation Gasolines.

(Applications for copies should be addressed to American Society for Testing and Materials, 100 Barr Harbor Drive, West Conshohocken, PA 19428-2959.)

## INTERNATIONAL ORGANIZATION FOR STANDARDS (ISO)

ISO 10012-1 - Equipment, Quality Assurance Requirements for Measuring - Part 1: Metrological Confirmation System for Measuring Equipment.

(Applications for copies should be addressed to American National Standards Institute, 11 West 42nd Street, New York NY 10036.)

MIL-DTL-9129E

RADIO TECHNICAL COMMISSION FOR AERONAUTICS

RTCA DO-160D - Environmental Conditions and Test Procedures for Airborne Equipment.

(Applications for copies should be addressed to Radio Technical Commission for Aeronautics, 1140 Connecticut Avenue NW, Suite 1020, Washington, DC 20036.)

SOCIETY OF AUTOMOTIVE ENGINEERS

SAE AMS 1435 - Fluid, Generic, Deicing/Anti-Icing Runways and Taxiways.

(Applications for copies should be addressed to Society of Automotive Engineers Inc., 400 Commonwealth Drive, Warrendale PA 15096-0001.)

2.4 Order of precedence. In the event of a conflict between the text of this document and the references cited herein (except for related associated specifications, specification sheets, or MS sheets), the text of this document takes precedence. Nothing in this document, however, supersedes applicable laws and regulations unless a specific exemption has been obtained.

3. REQUIREMENTS

3.1 Specification sheets. The individual item requirements shall be as specified herein and in accordance with the applicable specification sheets. In the event of any conflict between requirements of this specification and the specification sheets, the latter shall govern.

3.2 Qualification. Dischargers furnished under this specification shall be products which are authorized by the qualifying activity for listing on the applicable qualified products list at the time set for opening of bids (see 4.4 and 6.3).

3.2.1 Product modification. Dischargers, qualified under the provisions of this specification, shall not be subsequently altered in manufacture by substitution of materials, design or any other manner to the extent that compliance with the requirements of this specification could be affected.

3.3 First article inspection. Unless otherwise specified (see 4.5), dischargers furnished under this specification, not covered by specification sheets, shall be a product which has been tested and passed all applicable inspections specified in 4.4.

3.3.1 Information to be furnished with sample. The applicable information, outlined in 6.4, shall be furnished with the sample together with any other pertinent information as required by the Government.

3.4 Materials. Materials shall be as specified herein and the applicable specification sheet (see 3.1). Materials that are not specifically designated shall be inherently fungus resistant and possess such other overall characteristics as to provide for the furnished discharger to meet the requirements of this specification. Acceptance or approval of any constituent material shall not be construed as a guaranty of the acceptance of the finished product.

3.4.1 Metals. All metals used in the construction of the dischargers covered by this specification shall be corrosion resistant or protectively treated to resist corrosion in consonance with the performance requirements specified herein. When dissimilar metals are used in contact with each other, protection against electrolysis and corrosion shall be provided. Metal plating or metal spraying of dissimilar base metals to provide similar or suitable abutting surfaces is permitted. Dissimilar metals are defined in MIL-STD-889.

3.4.2 Nonmetallic materials. Nonmetallic materials and coatings shall not crack, chip, or otherwise deteriorate under temperature extremes, vibration, shock, and moisture conditions. Current carrying, nonmetallic materials shall provide permanent conductivity to the degree that will assure that the complete discharger meets the requirements of this specification.

3.5 Design and construction. Dischargers covered by this specification shall be of the design, construction, and physical dimensions specified herein and in the individual specification sheet (see 3.1).

## MIL-DTL-9129E

3.5.1 Mounting. The type of mounting shall be as specified in the individual specification sheet (see 3.1).

3.5.1.1 Adhesives. Dischargers depending upon adhesives for attachment to the aircraft shall be so designed that the tip or body assemblies may be replaced without detachment or replacement of the mounting bracket or base.

3.5.2 Screw threads. Screw threads on removable parts shall be in accordance with FED-STD-H28.

3.6 Performance. Unless otherwise specified (see 3.1), static dischargers shall meet the following performance requirements.

3.6.1 Discharge current. Unless otherwise specified (see 3.1), the discharge current shall be not less than 10 microamperes at a potential difference of 40 kV, applied across 6 inch spacing between the discharger tip and the grounded plate as in figure 1. (see 4.6.2.1)

3.6.2 Radio frequency discharge noise. Unless otherwise specified (see 3.1), the radio frequency total noise voltage (root mean square (rms) value of radio frequency generated and coupled by a discharger while it is discharging current at a rate of 50 microamperes shall be a minimum of either 40 dB (for trailing edge types) or 30 dB (for wing tip types) below the simulated trailing edge when measured in accordance with paragraph 4.6.2.2.

3.6.2.1 Noise voltage peaks. Any peaks of noise voltage at discrete frequencies within the passband shall not exceed the mean noise voltage by more than 20 dB, nor shall this level be permitted to occupy more than 10 percent of total passband width.

3.6.3 Continuous discharge. Continuous discharge capability shall be a minimum of 50 microamperes for a period of not less than 24 hours without material breakdown or other damage, and shall be capable of meeting the discharge current, radio frequency noise and direct current resistance requirements subsequent to the continuous discharge test (see 3.6.1, 3.6.2, 3.6.6 and 4.6.2.3).

3.6.4 Power Dissipation (see 3.1). The discharger shall withstand a continuous power of 5 watts for a period of 15 seconds without excessive heating (refer to Figure 2 for applied current requirement). The discharger shall be considered to have failed if:

- a. The post test discharger resistance exceeds the limits specified in 3.6.6.
- b. The temperature rise of the discharger during the 15 second application of power exceeds 25°C.
- c. The current flow, as indicated by the oscilloscope in figure 4, shows irregularities of "noise", other than that directly due to power supply output voltage ripple.

3.6.5 Electrical flashover. The discharger resistance shall remain within specified resistance limits when tested in accordance with 4.6.3. The dischargers shall be capable of meeting the discharge current and radio frequency discharge noise requirements subsequent to the flashover test (see 3.6.1 and 3.6.2).

3.6.6. Direct current resistance. The resistance of dischargers measured from discharge points to discharger mounting base shall be at 25°C (see 4.6.4):

- a. Trailing edge mounted = 6 to 200 megohms.
- b. Tip mounted = 6 to 120 megohms.
- c. Resistance shall be measured with a 500 volt minimum megohmmeter.

3.6.6.1 Resistance (-60°C to +45°C). The resistance of dischargers shall remain within specified limits when measured at the extreme temperatures of -60°C and +45°C, compared to the resistance measured at 25°C (see 4.6.4).

## MIL-DTL-9129E

3.6.7 Lightning transfer. Dischargers are to be tested for lightning transfer characteristics between the discharger holder section and a simulated aircraft skin (see 4.6.5). RTCA/DO-160D Section 23, zone 2A will be used. The current will be passed through the discharger holder and into the simulated skin. After the passing of the above current, the discharger and holder assembly (if applicable) shall remain intact (see 4.6.5).

3.6.8 Vibration. Dischargers shall be capable of withstanding high frequency vibration without physical damage when tested as specified in 4.6.6.

3.6.9 Shock. Dischargers shall be designed and constructed to withstand specified shock load with no physical damage (see 4.6.7).

3.6.10 Solvent resistance. Dischargers shall show no signs of deterioration from solvent materials when tested as specified in 4.6.8.

3.6.11 Thermal shock. Temperature extremes specified in 4.6.9 shall not result in any damage, or alter the function or operation of any of the dischargers covered by this specification.

3.6.12 Salt spray (corrosion). There shall be no evidence of excessive corrosion. Excessive corrosion is defined as that which interferes with the electrical or mechanical performance, or in the case of plated metals, corrosion which has passed through the plating and attacked the base metal. There shall be no warping, cracking, or other electrical or mechanical damage to the discharger (see 4.6.10).

3.6.13 Tension. All dischargers shall be so designed and constructed that their attachment into end components and onward into the mounting adapter (if any) shall withstand without damage a load applied as in 4.6.11. The discharger tip assembly shall similarly withstand a load of 10 pounds.

3.6.14 Sand and dust. When tested as specified in 4.6.12, dischargers shall be capable of withstanding sand and dust. There shall be no evidence of excessive abrasion that will interfere with the electrical or mechanical performance. There shall be no evidence of warping, cracking or other electrical or mechanical damage to the discharger (see 4.6.12).

3.6.15 Magnetism. In order for a discharger to qualify as a non-magnetic discharger, it must pass the test specified in 4.6.13.

3.6.16 Lightning survivability. In order to qualify as a lightning survivable discharger a unit must be tested per RTCA/DO-160D Section 23, zone 1A. Following completion of this test, the unit shall remain intact and shall meet the requirements of paragraphs 3.6.1 and 3.6.2 (see 4.6.14).

3.7 Marking. Dischargers shall be permanently and legibly marked in accordance with MIL-STD-1285 and shall include the following information:

- a. Military part number.
- b. Manufacturer's part number and name is optional.
- c. Manufacturer's CAGE.
- d. Date code. The date code shall consist of "MFD", followed by a four-digit number in which the first two digits indicate the month and the last two digits indicate the year; i.e., "MFD-0500" indicates a unit manufactured in May of 2000.

3.8 Recycled, recovered, or environmentally preferable materials. Recycled, recovered, or environmentally preferable materials should be used to the maximum extent possible provided that the material meets or exceeds the operational and maintenance requirements, and promotes economically advantageous life cycle costs.

3.9 Workmanship. Dischargers shall be processed in such a manner as to be uniform in quality and shall be free from cracked, loose, or displaced parts, sharp edges, burrs, and other defects that will affect life, serviceability, or ability to meet the requirements of this specification.

## MIL-DTL-9129E

## VERIFICATION

4.1 Classification of inspections. The inspection requirements specified herein are classified as follows:

- a. First article inspection (see 4.4).
- b. Conformance inspection (see 4.5).

4.2 Test equipment and inspection facilities. The manufacturer shall establish and maintain a calibration system in accordance with ANSI Z540, ISO 10012-1, or equivalent system as approved by the qualifying activity.

4.2.1 Mounting for test. Unless otherwise specified, the dischargers shall be mounted by the normal method, including the use of appropriate adhesives if applicable. Non-integral dischargers shall be tested with all applicable holders as specified in the specification sheets.

4.3 Inspection conditions. Unless otherwise specified herein, all inspections shall be performed in accordance with the test conditions specified in the "GENERAL REQUIREMENTS" of MIL-STD-202.

4.4 First article inspection. First article inspection shall be performed by the manufacturer on sample units produced with equipment and procedures normally used in production, after award of the contract and prior to production, at a laboratory acceptable to the government (see 6.3).

4.4.1 Sample. Unless otherwise specified, 10 dischargers (see 3.1) shall be submitted for first article inspection. The sample shall be taken from a production run or shall be produced with equipment and procedures normally used in production. An additional two samples shall be required for dischargers being inspected to include the magnetism characteristic (see 3.6.15). An additional two samples shall be required for dischargers being inspected to include the lightning survivability characteristic (see 3.6.16).

4.4.2 Inspection routine. The sample units shall be subjected to the first article inspection specified in table I in the order shown. All sample units shall be appropriately coded or otherwise identified to indicate the tests to which each was subjected. All units shall be subjected to the group I inspection. After group I inspection, the sample units shall be divided and subjected to inspection specified in table I. Non-integral dischargers that can interface with multiple holders shall be subject to the applicable tests in table I with only one of those holders. After completion of the tests in table I with one of the holders, dischargers shall be tested for vibration, lightning transfer and salt spray with each additional holder listed in the specification sheets. There shall be two sample units subjected to vibration, lightning transfer and salt spray, tested sequentially in that order.

4.4.3 Failure. Failure in any of the applicable inspection elements shall be cause for refusal to accept the first article inspection.

4.4.4 Test verification and samples. The manufacturer shall provide verification to the procuring activity that the first article inspection has been performed on the samples supplied to the requirements of this specification. The tested dischargers shall be identified to indicate the applicable tests to which each has been subjected. The Government reserves the right to require the manufacturer to furnish additional untested samples.

4.5 Conformance inspection.

4.5.1 Inspection of product for delivery. Inspection of product for delivery shall consist of groups A and B.

4.5.1.1 Inspection lot. An inspection lot shall consist of all dischargers of the same type produced under essentially the same conditions, and offered for inspection at one time. The lot may include the entire contract quantity, or it may be the production of any convenient time period at the choice of the Government inspector.

4.5.1.2 Group A inspection. Group A inspection shall consist of the inspections specified in table III, in the order shown.

4.5.1.2.1 Sampling plan. Group A inspection shall be on an inspection lot basis. Samples shall be selected in accordance with table II, based on the inspection lot. If there are one or more failures, the inspection lot shall be considered to have failed.

## MIL-DTL-9129E

TABLE I First article inspection.

Inspection	Requirement paragraph	Test method paragraph
<u>Group I (all sample units)</u>		
Visual and mechanical inspection	3.1, 3.4, 3.5, 3.7 and 3.8	4.6.1
Discharge current	3.6.1	4.6.2.1
Radio frequency discharge noise	3.6.2	4.6.2.2
<u>Group II (2 sample units)</u>		
Continuous discharge	3.6.3	4.6.2.3
Discharge current	3.6.1	4.6.2.1
Radio frequency discharge noise	3.6.2	4.6.2.2
<u>Group III (2 sample units)</u>		
Electrical flashover	3.6.5	4.6.3
Discharge current	3.6.1	4.6.2.1
Radio frequency discharge noise	3.6.2	4.6.2.2
Lightning transfer	3.6.7	4.6.5
<u>Group IV (2 sample units)</u>		
Direct current resistance	3.6.6	4.6.4
Power dissipation	3.6.4	4.6.2.4
Radio frequency discharge noise	3.6.2	4.6.2.2
<u>Group V (2 sample units)</u>		
Vibration	3.6.8	4.6.6
Shock	3.6.9	4.6.7
Discharge current	3.6.1	4.6.2.1
Radio frequency discharge noise	3.6.2	4.6.2.2
Salt spray	3.6.12	4.6.10
<u>Group VI (2 sample units)</u>		
Solvent resistance	3.6.10	4.6.8
Thermal shock	3.6.11	4.6.9
Discharge current	3.6.1	4.6.2.1
Radio frequency discharge noise	3.6.2	4.6.2.2
Tension	3.6.13	4.6.11
Sand and dust	3.6.14	4.6.12
<u>Group VII (2 sample units)</u>		
Lightning survivability	3.6.16	4.6.14
Discharge current	3.6.1	4.6.2.1
Radio frequency discharge noise	3.6.2	4.6.2.2
<u>Group VIII (2 sample units)</u>		
Magnetism	3.6.15	4.6.13

## MIL-DTL-9129E

TABLE II. Group A, zero defect sampling plan.

Lot size	Sample size
1 - 13	100 percent
14 - 150	13
151 - 280	20
281 - 500	29
501 - 1,200	34
1,201 - 3,200	42
3,201 - 10,000	50
10,001 - 35,000	60
35,001 - 150,000	74
150,001 - 500,000	90
500,001 and up	102

4.5.1.2.2 Rejected lots. If an inspection lot is rejected, the manufacturer may rework it to correct the defects, or screen out the defective units, and resubmit for inspection. Such lots shall be kept separate from new lots and shall be clearly identified as reinspected lots. If one or more defects are found in this second sample, the lot shall be rejected and shall not be supplied to this specification.

TABLE III Group A inspection.

Inspection	Requirement paragraph	Test method paragraph
Visual and mechanical inspection	3.1, 3.4, 3.5, 3.7 and 3.8	4.6.1
Discharge current	3.6.1	4.6.2.1
Radio frequency discharge noise	3.6.2	4.6.2.2

4.5.1.3 Group B inspection. Group B inspection shall consist of the tests specified in table IV, in the order shown.

4.5.1.3.1 Sampling plan. Group B inspection shall not be required for contracts or orders of less than 100 units. Dischargers shall be selected at random from sample units which passed group A inspection. The number of sample units required shall be as noted in table IV. Failure of any group B tests shall constitute rejection of the lot.

4.5.1.3.2 Rejected lots. If an inspection lot is rejected, the manufacturer may rework it to correct the defects, or screen out the defective units, and resubmit for reinspection. Resubmitted lots shall be inspected using tightened inspection. Such lots shall be separate from new lots, and shall be clearly identified as reinspected lots.

4.5.1.3.3 Disposition of sample units. Sample units which have passed group B inspection may be delivered on the contract or purchase order, if the represented lot is accepted and adhesive mountings were not used during the tests.

TABLE IV. Group B inspection.

Inspection	Requirement paragraph	Test method paragraph
(4 sample units)		
Direct current resistance	3.6.6	4.6.4
High discharge current	3.6.4	4.6.2.4
Discharge current	3.6.1	4.6.2.1
Radio frequency discharge noise	3.6.2	4.6.2.2

4.5.3 Periodic inspection. Periodic inspection shall consist of group C. Except where the results of these inspections show noncompliance with the applicable requirements (see 4.5.2.1.4), delivery of products which have passed groups A and B inspections shall not be delayed pending the results of these periodic inspections.



## MIL-DTL-9129E

4.5.3.1 Group C inspection. Group C inspection shall consist of the tests specified in table V, in the order shown. Group C inspection shall be performed on sample units selected from inspection lots that have passed groups A and B inspections. Group C inspection samples shall be representative of production.

4.5.3.1.1 Sampling plan. Group C inspection shall be performed every 24 months on six sample units. The sample shall be equally divided in three groups of two units each as specified in table V.

4.5.3.1.2 Failures. If one or more sample units fail to pass group C inspections, the sample lot shall be considered to have failed. In that event the cognizant inspection activity and the qualifying activity shall be notified immediately.

4.5.3.1.3 Disposition of sample units. Dischargers which have been subjected to group C inspection shall not be delivered on the contract or purchase order.

4.5.3.1.4 Noncompliance. If a sample fails to pass group C inspection, the manufacturer shall notify the qualifying activity and the cognizant inspection activity of such failure and take corrective action on the materials or processes, or both, as warranted, and on all units of product which can be corrected and which were manufactured with essentially the same materials and processes, and that are considered subjected to the same failure. Acceptance and shipment of the product shall be discontinued until corrective action, acceptable to the qualifying activity has been taken. After the corrective action has been taken group C inspection shall be repeated on additional sample units (all tests and examinations, or the test which the original sample failed, at the option of the qualifying activity). Groups A and B inspections may be reinstated; however, final acceptance and shipment shall be withheld until the group C reinspection has shown that the corrective action was successful. In the event of failure after reinspection, information concerning the failure shall be furnished to the cognizant inspection activity and the qualifying activity.

TABLE V. Group C inspection.

Inspection	Requirement paragraph	Test method paragraph
<u>Subgroup 1</u>		
Electrical flashover	3.6.5	4.6.3
Lightning transfer	3.6.7	4.6.5
<u>Subgroup 2</u>		
Vibration	3.6.8	4.6.6
Shock	3.6.9	4.6.7
Discharge current	3.6.1	4.6.2.1
Salt spray	3.6.12	4.6.10
<u>Subgroup 3</u>		
Solvent resistance	3.6.10	4.6.8
Thermal shock	3.6.11	4.6.9
Radio frequency discharge noise	3.6.2	4.6.2.2
Tension	3.6.13	4.6.11
Sand and dust	3.6.14	4.6.12

MIL-DTL-9129E

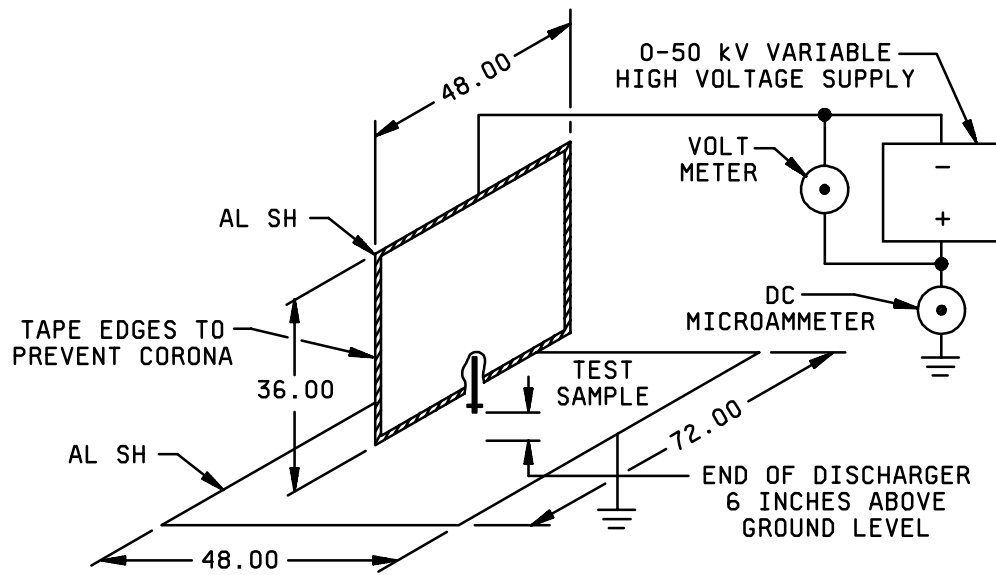

NOTES:

1. Dimensions are in inches.
2. Metric equivalents are given for information only.
3. Unless otherwise specified, the tolerance is  $\pm 12$  (3.0 mm).

FIGURE 1. Discharge current test configuration.

## MIL-DTL-9129E

STATIC DISCHARGERS  
5 WATT POWER DISSIPATION CURVE

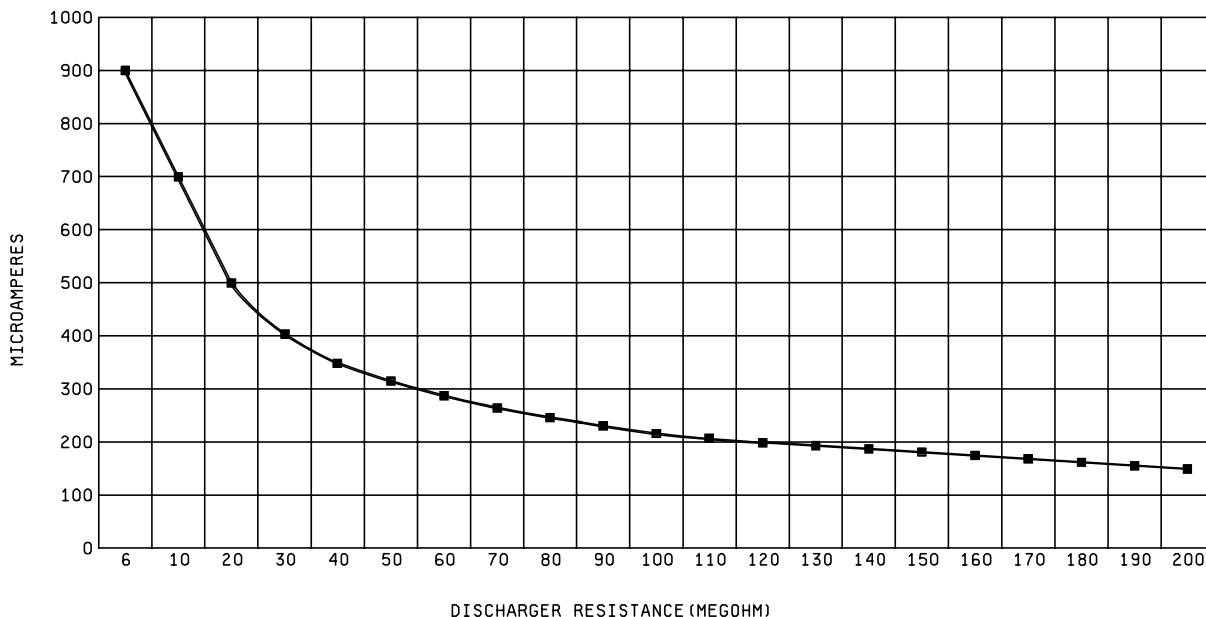

FIGURE 2. Power Dissipation test.

#### 4.6 Methods of inspection.

4.6.1 Visual and mechanical inspection. Dischargers shall be inspected to verify that the physical dimensions, materials, design, construction, marking, and workmanship are in accordance with the applicable requirements.

#### 4.6.2 Discharge current measurement and test.

4.6.2.1 Discharge current (see 3.6.1). Discharge current, voltage and spacing between the discharge points shall be measured, and recorded using the test configuration outlined in figure 1. Any leakage current in the test circuit with the discharger removed shall be subtracted from the specified test current when increasing the test voltage to the specified maximum. Ambient relative humidity and temperature shall be within the ranges of 40 to 60 percent and 16°C to 27°C, respectively.

4.6.2.2 Radio frequency discharge noise (see 3.6.2). Radio frequency discharge noise shall be measured using the test configuration outlined in figure 3. The tester shall be in accordance with Air Force Drawing 7136810. The rms voltmeter shall be a "J" Fluke Model 910A, Hewlett Packard Model 3400A, or equivalent. The amplifier, Tektronix type 1121 or equivalent, shall have an input impedance in excess of 1 megohm and a flat frequency response from 5 Hz to 17 MHz. The tester shall be calibrated using a 16 gauge solid metal wire 7 inches long with a radius of curvature on the discharge end equal to one half of the wire diameter. The rms noise voltage generated with the wire discharging 50  $\mu$ A will be measured and recorded as the calibration standard. This calibration standard is being specified as being 10 dB below the noise similarly generated by a simulated trailing edge. The discharger will then be installed and its rms noise voltage generated at 50  $\mu$ A shall be recorded. The dB noise difference between the simulated trailing edge and discharger shall meet the requirements of paragraph 3.6.2. When testing the calibration standard on the discharger, the end of the standard or the discharge area (as applicable) will break the plane of the cone in figure 3.

## MIL-DTL-9129E

4.6.2.3 Continuous discharge test (see 3.6.3). Dischargers shall be subjected to the specified discharge current and time period using the method outlined in figure 1 for applying the required current load. The distance between the test set electrode and the discharger points may be reduced for this test (if the discharge points do not physically contact the electrode) so that the required discharge current may be achieved without excessive voltage. A number of test sets may be operated in parallel with no more than one discharger in each test set, so long as the average recorded discharge current for each discharger is maintained at the required level. The discharger points shall be approximately centered with respect to the test set electrode face. Subsequent to continuous discharge tests, the dischargers shall be retested in accordance with 3.6.1, at the spacing previously recorded, and 3.6.2 for radio frequency discharge noise. Ambient relative humidity and temperature during the test period shall be 40 to 60 percent and 16°C to 27°C, respectively.

4.6.2.4 Power dissipation test (see 3.6.4). Dischargers shall be subjected to the specified continuous power (see figure 2) using the method outlined in figure 4.

4.6.3 Electrical flashover test (see 3.6.5). The direct current resistance of the discharger shall be measured before and after being subjected to five 200 joule electrical impulses. The resistance of the discharger after the impulses shall be within the specified tolerance, and the discharge current and radio frequency discharge noise (see 3.6.1 and 3.6.2) shall remain within the required limits. The test configuration shall be in accordance with that shown on figure 5.

4.6.4 Direct current resistance test (see 3.6.6). The direct current resistance shall be measured from the discharge area to the discharger mounting base after a stabilization/soak period of not less than 10 minutes at the specified temperature.

4.6.5 Lightning transfer (see 3.7). The discharger assembly shall be tested in accordance with zone 2A, current components B, C and D of RTCA/DO-160D, section 23, using a dwell time of 125 ms  $\pm$ 25 ms for the continuing current. The following details shall apply:

- a. Integral dischargers shall be mounted on an aluminum panel .08 inches thick, 12 by 12 inches with the appropriate mounting method procedure.
- b. Non-integral dischargers shall be mounted on their mating holder and the holder shall be attached to an aluminum panel .08 inches thick, 12 by 12 with the appropriate mounting method procedure. Measure the bond resistance between the discharger base and grounded aluminum panel. The resistance shall be 2.5 milliohms maximum.
- c. Position the probe within ½ inch of the discharger base. Resistance shall remain within the specified limits.
- d. Apply the current components. It may be required to reposition the probe after application of any one component in order to complete the remainder.
- e. Two dischargers shall be tested as above. The dischargers and holder assemblies (if applicable) shall remain intact.

4.6.6 Vibration (see 3.6.8). The discharger shall be tested in accordance with method 204 of MIL-STD-202. Discharger resistance shall remain within the specified limits. The following details shall apply:

- a. All dischargers less than 300 knots:
  - (1) Mounting - Securely attached to a rigid fixture by normal mounting (see 4.2.1).
  - (2) Test condition - C.
  - (3) Inspection after test - Inspect for broken, cracked, or loosened components.
- b. All dischargers less than 600 knots:
  - (1) Mounting - Securely attached to a rigid fixture by normal mounting (see 4.2.1).
  - (2) Test condition - D.

MIL-DTL-9129E

(3) Inspection after test - Inspect for broken, cracked, or loosened components.

c. All dischargers greater than 600 knots:

(1) Mounting - Securely attached to a rigid fixture by normal mounting (see 4.2.1).

(2) Test condition - E.

(3) Inspection after test - Inspect for broken, cracked, or loosened components.

4.6.7 Shock (see 3.6.9). The discharger shall be tested in accordance with method 213 of MIL-STD-202. Discharger resistance shall remain within the specified limits. The following details shall apply:

a. Mounting - Normal means (see 4.2.1).

b. Referenced surfaces - No special requirements.

c. Test condition - I.

d. Inspection after test - Inspect for broken, cracked, or loosened components.

4.6.8 Solvent resistance test (see 3.6.10). The discharger shall be submerged for a period of 1 hour, in each of the following materials:

a. Hydraulic fluid (MIL-H-5606).

b. Jet engine fuel (MIL-DTL-5624).

c. Gasoline (ASTM D910).

d. Deicing fluid (SAE AMS 1435).

After each soaking period, the discharger shall be inspected for deterioration of nonmetallic components and coatings. On completion of test, the discharger shall be thoroughly dried and inspected for softening or hardening of nonmetallic components and coatings caused by the exposure. The discharger resistance shall remain within the specified limits.

4.6.9 Thermal shock (see 3.6.11). The discharger shall be subjected to temperature cycling in accordance with method 107 of MIL-STD-202. The following details shall apply:

a. Test Condition A for dischargers less than 500 knots and test condition B for dischargers greater than 600 knots.

b. Measurements - Flexible discharger shall be hand flexed after removal from cold chamber and inspected for breaks or cracks. After completion of test, the discharger shall be inspected for deterioration of material and other damage.

## MIL-DTL-9129E

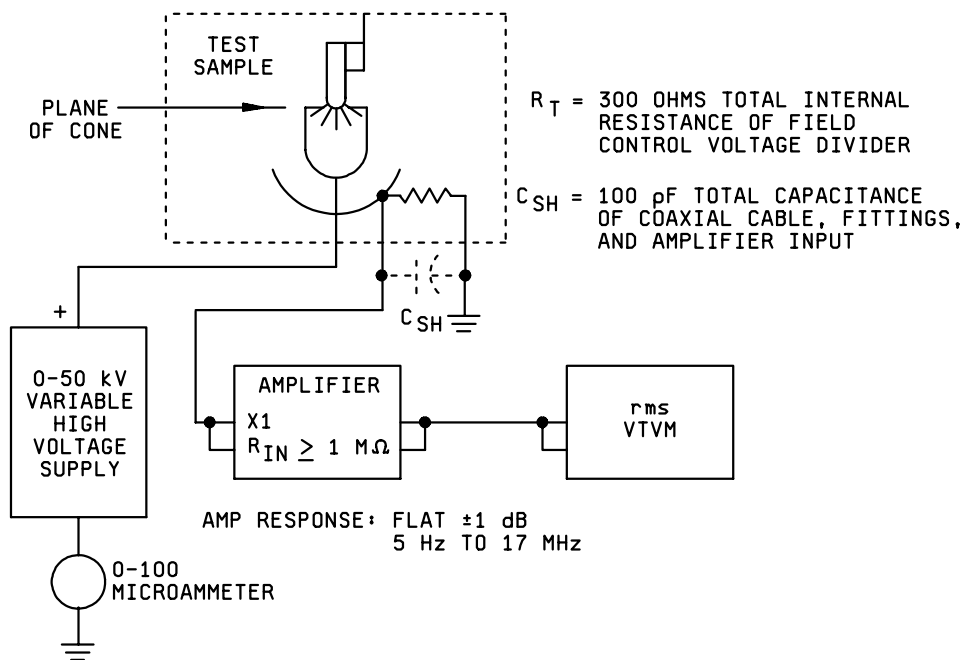
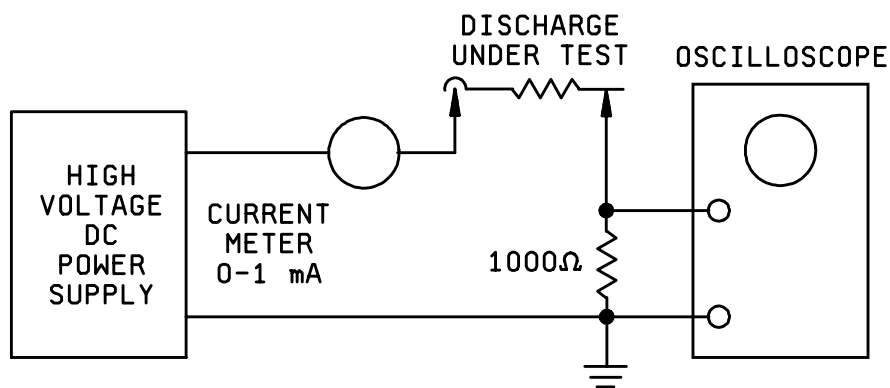
FIGURE 3. Radio frequency noise test configuration.

## NOTES

1. Adjust timer for "ON" time of 15 seconds.
2. Adjust high voltage power supply to produce a continuous power of 5 watts (see figure 2).
3. Discharger connection will be at manufacturer's discretion.

FIGURE 4. High current test configuration.

MIL-DTL-9129E

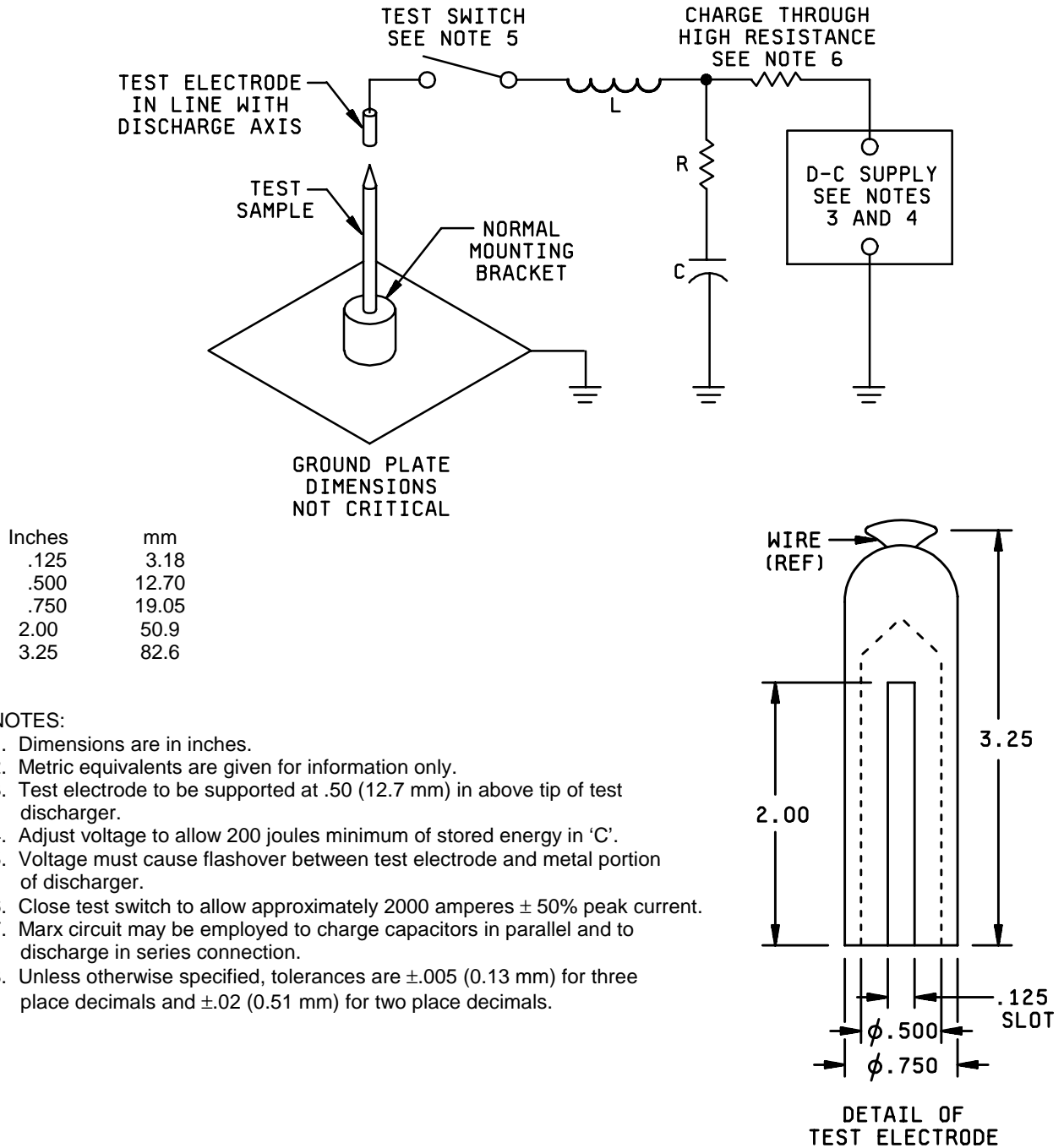
FIGURE 5. Electrical impulse test configuration.

## MIL-DTL-9129E

4.6.10 Salt spray (corrosion) (see 3.6.12). The discharger shall be tested in accordance with method 101 of MIL-STD-202. The following details shall apply:

- a. 5-percent salt solution.
- b. Test condition - B.
- c. Following the drying period, the dischargers shall be subjected to 100 percent of rated current for 1 hour.
- d. Following the test, dischargers shall be inspected for compliance with 3.6.6.

4.6.11 Tension test (see 3.6.13). The discharger shall be attached to a metal plate by normal method and subjected to a load of 50 pounds applied along the longitudinal discharger axis between the outer discharger extremities and mounting plate. After test, the discharger shall be inspected for breaks, cracks, separations, or other damage of components or coatings, and separation from the mounting plate.

4.6.12 Sand and dust (see 3.6.14). The discharger shall be tested in accordance with method 110 of MIL-STD-202. The following details shall apply:

- a. Test condition A for dischargers less than 600 knots. For dischargers greater than 600 knots, test condition A shall apply except that the specified velocity shall be  $2,500 \pm 500$  F.P.M.
- b. Following completion, the test dischargers shall meet the minimum requirements of group I and II of table I tests.

4.6.13 Magnetism (see 3.1 and 3.6.15). Dischargers shall be tested in accordance with NAVAIR 01-S3B-2-3-14-1 section 7.

4.6.14 Lightning survivability (see 3.1 and 3.6.16). Dischargers shall be tested in accordance with zone 1A, current components A and B of RTCA/DO-160D, section 23 as follows:

- a. Repeat the steps of paragraph 4.6.5, steps a through e using the current components A and B as stated above.
- b. Following completion of the test above, the discharger and holder assemblies (if applicable) shall be tested per paragraph 4.6.2.1 and 4.6.2.2 and remain within the required limits to be classified as a lightning survivable discharger.

## 5. PACKAGING

5.1 Packaging. For acquisition purposes, the packaging requirements shall be as specified in the contract or order (see 6.2). When actual packaging of materiel is to be performed by DoD personnel, these personnel need to contact the responsible packaging activity to ascertain requisite packaging requirements. Packaging requirements are maintained by the Inventory Control Point's packaging activity within the Military Department or Defense Agency, or within the Military Department's System Command. Packaging data retrieval is available from the managing Military Department's or Defense Agency's automated packaging files, CD-ROM products, or by contacting the responsible packaging activity.

## 6. NOTES

(This section contains information of a general or explanatory nature that may be helpful, but is not mandatory.)

### 6.1 Intended use.

6.1.1 Dischargers. Dischargers covered by this specification are for use in the reduction of aircraft precipitation static discharge interference to radio communications and navigational systems.



MIL-DTL-9129E

6.2 Ordering data. Acquisition documents should specify the following:

- a. Title, number, and date of this specification.
- b. Military part number (see 3.1).
- c. Title, number, and date of the applicable specification sheet (see 3.1).
- d. Packaging requirements (see 5.1).
- e. If special or other identification marking is required (see 5.1).

6.3 First article inspection. Information pertaining to first article inspection of products covered by this specification should be obtained from the acquiring activity for the specific contracts involved. Acquisition documents should specify the following:

- a. Title, number, and date of this specification.
- b. Military or commercial part number, as applicable.
- c. Samples, verification, and test routine, if other than specified (see 4.4.4).
- d. Design and construction (see 3.5).
- e. Performance requirements (see 3.1).

6.4 Warning. Potentially hazardous situations could develop in some of the test procedures specified in this specification. Precautions should therefore be taken to insure that test personnel are adequately protected and observe the necessary safety measures at all times.

6.5 Subject (key word) listing.

Discharge current  
Lightning survivability  
Magnetism  
Radio frequency discharge noise

6.6 Changes from previous issue. Asterisks are not used in this revision to identify changes with respect to the previous issue due to the extent of the changes.

Custodians:

Army - CR  
Navy - AS  
Air Force - 11  
DLA - CC

Preparing activity

DLA - CC

(Project 5920-0721)

Review activities:

Army - CE, MI  
Navy - MC  
Air Force - 19, 99

## STANDARDIZATION DOCUMENT IMPROVEMENT PROPOSAL

### INSTRUCTIONS

1. The preparing activity must complete blocks 1, 2, 3, and 8. In block 1, both the document number and revision letter should be given.
2. The submitter of this form must complete blocks 4, 5, 6, and 7, and send to the preparing activity.
3. The preparing activity must provide a reply within 30 days from receipt of the form.

NOTE: This form may not be used to request copies of documents, nor to request waivers, or clarification of requirements on current contracts. Comments submitted on this form do not constitute or imply authorization to waive any portion of the referenced document(s) or to amend contractual requirements.

<b>I RECOMMEND A CHANGE:</b>	<b>1. DOCUMENT NUMBER</b> MIL-DTL-9129E	<b>2. DOCUMENT DATE (YYMMDD)</b> 12 April 2001
<b>3. DOCUMENT TITLE</b> DISCHARGERS, ELECTROSTATIC, GENERAL SPECIFICATION FOR		
<b>4. NATURE OF CHANGE</b> <i>(Identify paragraph number and include proposed rewrite, if possible. Attach extra sheets as needed.)</i>		
<b>5. REASON FOR RECOMMENDATION</b>		
<b>6. SUBMITTER</b>		
a. NAME <i>(Last, First, Middle initial)</i>	b. ORGANIZATION	
c. ADDRESS <i>(Include Zip Code)</i>	d. TELEPHONE <i>(Include Area Code)</i> (1) Commercial  (2) DSN <i>(If applicable)</i>	7. DATE SUBMITTED (YYMMDD)
<b>8. PREPARING ACTIVITY</b>		
a. NAME DEFENSE SUPPLY CENTER, COLUMBUS ATTN: DSCC-VAT	b. TELEPHONE <i>(Include Area Code)</i> (1) Commercial 614-692-0556                      (2) DSN 850-0556	
c. ADDRESS <i>(Include Zip Code)</i> 3990 EAST BROAD STREET COLUMBUS, OH 43213-1199	<b>IF YOU DO NOT RECEIVE A REPLY WITHIN 45 DAYS, CONTACT:</b>  Defense Standardization Program Office (DLSC-LM) 8725 John J. Kingman Road, Suite 2533 Fort Belvoir, Virginia 22060-6221 Telephone (703) 767-6888    DSN 427-6888	