

INCH-POUND

MIL-DTL-8834J
w/Amendment 1
23 August 2012
SUPERSEDING
MIL-DTL-8834J
23 March 2011

DETAIL SPECIFICATION

SWITCHES, TOGGLE, POSITIVE BREAK, GENERAL SPECIFICATION FOR

This specification is approved for use by all Departments and Agencies of the Department of Defense.

1. SCOPE

1.1 Scope. This specification covers the military service requirements for snap-action, non-teasable, positive-break and make, one-hole mounting toggle switches. These switches are intended for use in alternating current (ac) and direct current (dc) applications for dry circuit, low level, and power switching. The sealing characteristics covered by this specification include toggle sealed devices and environmentally sealed devices ([see 6.1](#)).

2. APPLICABLE DOCUMENTS

2.1 General. The documents listed in this section are specified in sections 3 and 4 of this specification. This section does not include documents cited in other sections of this specification or recommended for additional information or as examples. While every effort has been made to ensure the completeness of this list, document users are cautioned that they must meet all specified requirements documents cited in sections 3 and 4 of this specification, whether or not they are listed.

2.2 Government documents.

2.2.1 Specifications, standards, and handbooks. The following specifications, standards, and handbooks form a part of this document to the extent specified herein. Unless otherwise specified, the issues of these documents are those listed in the issue of the Department of Defense Index of Specifications and Standards (DoDISS) and supplement thereto, cited in the solicitation ([see 6.2](#)).

FEDERAL STANDARDS

[FED-STD-H28](#) - Screw Thread Standards for Federal Services.

COMMERCIAL ITEM DESCRIPTIONS

SPECIFICATIONS

[A-A-59588](#) - Rubber, Silicone

DEPARTMENT OF DEFENSE

SPECIFICATIONS

[MIL-PRF-15160/2](#) - Fuses, Instrument, Power, and Telephone (Non-indicating), style F02
[MIL-DTL-5423/16](#) - Boot, Dust, and Water Seal, Type A (For Toggle Switch 0.469 Diameter) Style 10 (Panel Bushing Seal Only).

Comments, suggestions or questions on this document should be addressed to DLA Land and Maritime, ATTN: VAT, Post Office Box 3990, Columbus, OH 43218-3990, or emailed to switch@dla.mil . Since contact information can change, you may want to verify the currency of this address information using the ASSIST Online database at https://assist.dla.mil/ .
--

MIL-DTL-8834J w/Amendment 1

STANDARDS

- [MIL-STD-202](#) - Test Method Standard for Electronic and Electrical Component Parts.
- [MIL-STD-1285](#) - Marking of Electrical and Electronic Parts.

(Copies of these documents are available online at <https://assist.dla.mil> or from the Standardization Document Order Desk, 700 Robbins Avenue, Building 4D, Philadelphia, PA 19111-5094.)

2.3 Non-Government publications. The following document(s) form a part of this document to the extent specified herein. Unless otherwise specified, the issues of the documents which are DoD adopted are those listed in the issue of the DoDISS cited in the solicitation. Unless otherwise specified, the issues of documents not listed in the DoDISS are the issues of the documents cited in the solicitation ([see 6.2](#)).

AMERICAN SOCIETY FOR QUALITY (ASQ)

- [ASQ ISO/IEC 17025](#) - General requirements for the competence of testing and calibration laboratories

(Application for copies can be found online at <http://www.asq.org/> or 600 North Plankinton Ave., Milwaukee, WI 53203, telephone 414-272-8575, fax 414-272-1734).

ASTM INTERNATIONAL

- [ASTM E1119](#) - Glycol, Industrial Grade Ethylene, Standard Specification for.
- [ASTM G21](#) - Materials To Fungi, Synthetic Polymeric, Determining Resistance of

(Application for copies can be found online at <http://www.astm.org/> or should be addressed to the ASTM International, 100 Barr Harbor Drive, P.O.Box C700, West Conshohocken, PA, 19428-2959).

INTERNATIONAL ORGANIZATION FOR STANDARDS (ISO)

- [ISO 10012-1](#) - Quality Assurance Requirements for Measuring Equipment - Part 1; Meterological Confirmation System for Measuring Equipment.

(Application for copies can be found online at <http://www.ansi.org> or should be addressed to the American National Standards Institute (ANSI), 25 West 43rd Street, New York, NY 10036-8002, telephone 212-642-4900, fax 212-302-1286).

SAE International

- [SAE-AS50861](#) - Wire, Electric, Polyvinyl Chloride Insulated, Copper or Copper Alloy
- [SAE-AS58091](#) - Circuit Breakers, Trip-Free, Aircraft, General Specification for
- [SAE-AS7928](#) - Terminals, Lug: Splices, Conductor: Crimp Style, Copper, General Specification for

(Application for copies can be found online at <http://www.sae.org> or should be addressed to the SAE International World Headquarters, 400 Commonwealth Drive, Warrendale, PA 15096-0001)

2.4 Order of precedence. In the event of a conflict between the text of this document and the references cited herein (except for related associated specifications or specification sheets, the text of this document takes precedence. Nothing in this document, however, supersedes applicable laws and regulations

MIL-DTL-8834J w/Amendment 1

3. REQUIREMENTS

3.1 Detail requirements for individual types of switches. Detail requirements applicable to individual types of switches shall be as specified in the applicable MS. In the event of any conflict between the requirements of this specification and the MS, the latter shall govern ([see 6.2](#)).

3.2 Switch categories. Switches furnished under this specification shall be category I and category II as defined in [3.2.1 and 3.2.2](#), respectively.

3.2.1 Category I switches. Switches completely defined by an MS military standard (see [3.1](#)).

3.2.2 Category II switches (see 6.2.2). Category II switches are the same as category I switches except for minor differences such as termination, configuration, operating characteristics, and minor actuator variations that do not change the basic design or construction of the qualified switch. Category II switches shall be acquired from a source listed on the qualified products list for the particular similar product in category I. Category II switches are nonstandard.

3.3 Qualification. Category I switches furnished under this specification shall be products which are qualified for listing on the applicable qualified products lists at the time set for opening of bids.

3.4 Material. Unless otherwise approved by the preparing activity, material shall be as specified herein. When a definite material is not specified, a suitable material shall be used which enables the switches to conform to the performance requirements of this specification. Reclaimed materials shall be utilized to the maximum extent possible. Acceptance or approval of any constituent material shall not be construed as a guaranty of the acceptance of the finished product.

3.4.1 Metals. All metal parts shall be of corrosion-resistant material, or shall be suitably protected to resist corrosion. Paint is not acceptable for corrosion protection. Ferrous material shall not be used for current-carrying parts.

3.4.1.1 Dissimilar metals. When dissimilar metals are used in intimate contact with each other, protection against electrolysis and corrosion shall be provided. The use of dissimilar metals which, in contact, tend toward active electrolytic corrosion (particularly brass, copper, or steel used in contact with aluminum or aluminum alloy) is not acceptable. However, metal plating or metal spraying of dissimilar metals to provide similar or suitable abutting surfaces is permitted. The use of dissimilar metals separated by a suitable insulating material is also permitted. Dissimilar metals and compatible couples are defined in [6.8](#) through [6.8.4](#), inclusive, and [table VII](#).

3.4.1.2 Pure tin. The use of pure tin, as an underplate or final finish, is prohibited both internally and externally. Tin content of switch components and solder shall not exceed 97 percent, by mass. Tin shall be alloyed with a minimum of 3 percent lead, by mass (see [6.8.5](#))

3.4.2 Plastic materials. Unless otherwise specified ([see 3.1](#)), molded plastic material, when used, shall be selected to enable the switch to meet performance requirements of this specification. Stacked laminations shall not be used for the switch body. Other types of plastic materials may be used provided the manufacturer submits acceptable evidence of performance to the qualifying activity during the qualification test program on the submitted product.

3.4.2.1 Fungus-resistance. All material shall be inert or fungus resistant in accordance with guideline 4 of [ASTM G21](#).

3.4.3 Elastomer seals. The material for all elastomer seals shall be silicone rubber in accordance with [A-A-59588](#). Other types of silicone rubber may be used provided the manufacturer submits acceptable evidence of performance to the preparing activity during the qualification test program on the submitted product.

MIL-DTL-8834J w/Amendment 1

3.5 Design and construction. The switches shall be of the design, construction, and physical dimensions specified ([see 3.1 and 3.2](#)). The switching action shall be such that the speed of the moving contacts is relatively independent of the actuating mechanism and that once contact movement has started, the motion cannot be stopped before the switching action is completed. Means shall be provided to impart direct, positive breaking between the operating lever and the contact member so that positive opening or closing of the contacts by the operating lever can be effected through a direct mechanical linkage between the movable contact member and the operating lever of the switch.

3.5.1 Actuating lever. The actuating lever shall be metal, shall have a lusterless finish, and shall be insulated from all current-carrying parts.

3.5.2 Attitude. Switches shall be constructed so as to assure proper operation when mounted in any position.

3.5.3 Terminals. Terminals shall be as specified ([see 3.1](#)). Only the number of terminals required to accomplish the circuit characteristic shall be furnished.

3.5.3.1 Solderable terminals. Solderable terminals shall be treated to facilitate soldering. Silver plating shall not be used as the external coating. When gold plating is used because the terminals are integral with the gold contacts, its thickness shall be a minimum of 30 millionths of an inch and a maximum of 100 millionths of an inch. Terminals shall be designed so that wires can be mechanically secured prior to soldering. Terminals may be tapped or drilled after coating.

3.5.3.2 Screw terminals. Screw terminals shall be provided with the hardware specified ([see 3.1](#) and the [appendix A](#) herein).

3.5.4 Mounting bushing. The mounting bushing shall be as specified ([see 3.1](#)). The bushing shall be provided with a seal between the toggle lever and the switching mechanism. The body of the elastomer seal shall not protrude from the top of the mounting bushing with the exception of the tapered joint or meniscus where the seal joins the toggle lever, which may be permitted to exceed the height of the mounting bushing, but not interfere with operation of toggle lever.

3.5.5 Hardware. For direct Government acquisition, all hardware ([see 3.1](#)), shall be supplied in a separate package and packaged with the switch. Crimp pin contacts, for switches with integrated wire termination, are not supplied with the switch. Unless otherwise specified ([see 6.2](#)), QPL sources may provide switches to sources other than the Government, with hardware packaged separately or with specified hardware. Switches packaged separately may be marked with the appropriate MS or M part numbers.

3.5.5.1 Mounting hardware. The mounting hardware shall be as specified ([see 3.1](#)).

3.5.5.2 Terminal hardware. The terminal hardware shall be as specified ([see 3.1](#)).

3.5.6 Antirotational means. All switches shall be designed to have an antirotational mounting means which shall be as specified ([see 3.1](#)).

3.5.7 Screw threads. Screw threads on external threaded parts shall be in accordance with [FED-STD-H28](#). Threading of nonmetallic parts shall not be permitted. Terminal thread engagement shall be at least two full threads.

3.5.8 Solder. Where soldering is employed, only noncorrosive fluxes shall be used. Solder shall not be used on the interior of switches with solderable external contacts.

3.5.9 Weight. Weight shall be as specified ([see 3.1](#)).

3.6 Performance.

3.6.1 Solderability (applicable to solderable terminals). When switches are tested as specified in [4.8.2](#), the criteria for acceptable solderability shall be in accordance with [method 208 of MIL-STD-202](#).

MIL-DTL-8834J w/Amendment 1

3.6.2 Resistance to soldering heat (applicable to solderable terminals). When switches are tested as specified in [4.8.3](#), the switches shall remain operable. When opened, there shall be no internal deformation or damage.

3.6.3 Switching characteristics. When switches are tested as specified in [4.8.4](#), they shall operate as specified ([see 3.1](#)).

3.6.4 Strength of terminals. When switches are tested as specified in [4.8.5](#), there shall be no breakage, loosening, or rotating of terminals, and no damage to the switch body.

3.6.5 Strength of actuating-lever pivot and lever stop. When switches are tested as specified in [4.8.6](#), there shall be no malfunction damage, breakage, or short circuit; switches shall operate mechanically and electrically.

3.6.6 Strength of mounting bushing. When switches are tested as specified in [4.8.7](#), there shall be no loosening of the mounting bushing or other mechanical damage.

3.6.7 Mechanical endurance. When switches are tested as specified in [4.8.8](#), there shall be no deterioration of the toggle seal, mechanical breakage, or malfunction. Circuitry and degree of toggle lever movement shall be as specified ([see 3.1](#)). For momentary switches, return from the actuated position shall be caused solely by the internal mechanism of the switch.

3.6.8 Contact bounce (when specified, see 3.1). When switches are tested as specified in [4.8.9](#), the contact bounce shall not exceed the value specified ([see 3.1](#)).

3.6.9 Contact voltage drop. When switches are tested as specified in [4.8.10](#), the contact voltage drop shall not exceed 1 millivolt.

3.6.10 Dielectric withstanding voltage. When switches are tested as specified in [4.8.11](#), the switches shall withstand the application of the specified voltages without arcing, flashover, breakdown of insulation, or damage; there shall be no momentary flashover or leakage in excess of 500 microamperes.

3.6.11 Electrical overload, endurance, life, low level dry circuit and intermediate current switching, and temperature rise. When switches are tested as specified in [4.8.12](#), each pair of switch contacts under test shall open and close the circuit in proper sequence during each cycle of the switch actuating member. There shall be no external evidence of malfunction or damage during or after the test, and any blown fuse or tripped circuit breaker shall constitute failure. When switches are tested as specified in [4.8.12.6](#), the temperature rise of the switch terminals shall not exceed 50°C. At the conclusion of the test, the switch shall be electrically and mechanically operable while controlling the test load, at the test environment and at room conditions. Electrical tolerances are as follows:

Voltage:	±5 percent for 28 V dc, 125 V dc, and 250 V dc. ±7 percent for 125 V ac and 250 V ac.
Frequency:	±5 percent.
Current:	±5 percent.

3.6.12 Short circuit closure. When switches are tested as specified in [4.8.13](#), the switch contacts under test shall open after each closure operation, and there shall be no mechanical failure.

3.6.13 Shock. When switches are tested as specified in [4.8.14](#), the opening or closing of contacts shall not exceed 10 microseconds for method I ([see 3.1](#)) and 20 milliseconds for method II ([see 4.8.14.2](#)).

3.6.14 Vibration, high frequency. When switches are tested as specified in [4.8.15](#), there shall be no separation of closed contacts or closure of open contacts having a duration exceeding 10 microseconds. There shall be no evidence of damage.

3.6.15 Salt spray. When switches are tested as specified in [4.8.16](#), there shall be no warping, cracking, corrosion which exposes base material, or other damage, and the specified cycling shall be completed without failure. After the test, the mounting hardware shall be readily removable.

MIL-DTL-8834J w/Amendment 1

3.6.16 Moisture resistance. When switches are tested as specified in [4.8.17](#), there shall be no electrical failures, or breaking, spalling, cracking, or loosening of terminals.

3.6.17 Toggle ice. When switches are tested as specified in [4.8.18](#), there shall be no mechanical damage to the toggle seal or to the switch.

3.6.18 Sand and dust. When switches are tested as specified in [4.8.19](#), they shall be electrically and mechanically operable as evidenced by ability to control a pilot-lamp circuit.

3.6.19 Thermal shock. When switches are tested as specified in [4.8.20](#), there shall be no mechanical or electrical damage, or loosening of rivets or other fastening devices, and there shall be electrical continuity between closed contacts only.

3.6.20 Sealing (see 4.8.21).

3.6.20.1 Toggle seal (water) (applicable to toggle sealed switches only). When the seal is tested as specified in [4.8.21.1](#), water shall not enter the interior of the switch.

3.6.20.2 Environmental seal test (applicable to environmentally sealed switches only) (see 4.8.21.2).

3.6.20.2.1 Temperature cycling submersion (applicable for qualification and group B tests only). When switches are tested as specified in [4.8.21.2.1](#), there shall be no mechanical or electrical failures, and they shall meet the requirement for contact voltage drop ([see 3.6.9](#)) and dielectric withstanding voltage ([see 3.6.10](#)).

3.6.20.2.2 Leakage test mass spectrometer (applicable for group A tests only). Unless otherwise specified, the leakage rate shall not exceed 30×10^{-5} standard atmospheric cubic centimeters per second (atm cm³/s) when switches are tested as specified in [4.8.21.2.2](#).

3.6.21 Explosion (toggle seal switches only). When switches are tested as specified in [4.8.22](#), there shall be no explosion within the test chamber whether or not explosion occurs within the switch.

3.6.22 Flammability. When switches are tested as specified in [4.8.23](#), plastic materials used in all external switch parts and enclosures shall be self-extinguishing.

3.7 Marking.

3.7.1 Identification of product. Switches shall be marked in accordance with [MIL-STD-1285](#) as follows:

- a. Military Part or Identifying Number (PIN)(category I only).
- b. Manufacturer's PIN (category II).
- c. Manufacturer's name, trademark, or source code.
- d. Date code.
- e. Switch positions (on-off).
- f. Terminal identification (when specified.)

3.7.1.1 Marking permanency (applicable to switches with printed circuit board terminals only). When switches are tested as specified in [4.8.24](#), all marking shall remain legible.

3.7.2 Terminal identification. When specified ([see 3.1](#)), terminals shall be permanently marked in accordance with [figure 1](#) by either raised or depressed marking. Terminal marking by ink stamping on the side of the switch case is permissible if specified ([see 3.1](#)).

MIL-DTL-8834J w/Amendment 1

3.8 Workmanship. Switches shall be processed in such a manner to be free from cracked or displaced parts, sharp edges, burrs, and other defects which will affect life, serviceability, or appearance.

4. VERIFICATION

4.1 Classification of inspection. The examination and testing of switches shall be classified as follows:

- a. Materials inspection ([see 4.3](#)).
- b. Qualification inspection ([see 4.5](#)).
- c. Inspection requirements for category II switches ([see 4.6](#)).
- d. Conformance inspection ([see 4.7](#)).

4.2 Test equipment and inspection facilities. Test and measuring equipment and inspection facilities of sufficient accuracy, quality, and quantity to permit performance of the required inspection shall be established and maintained by the contractor. The establishment and maintenance of a calibration system to control the accuracy of the measuring and test equipment shall be in accordance with [ASQ ISO/IEC 17025](#), [ISO-10012-1](#), or equivalent system as approved by the qualifying activity.

4.3 Materials inspection. Materials inspection shall consist of certification supported by verifying data that the materials listed in [table I](#) used in fabricating the switches, are in accordance with the applicable referenced specifications or requirements prior to such fabrication, or shall state whether other materials are used. With the qualification test report, the manufacturer shall submit a cross-reference list of the switch parts and the materials used to fabricate those parts.

4.4 Inspection conditions. Unless otherwise specified, all inspections shall be performed in accordance with the test conditions specified in the "GENERAL REQUIREMENTS" of [MIL-STD-202](#).

4.5 Qualification inspection (category I switches, see 3.1 and 3.3). Qualification inspection shall be performed at a laboratory acceptable to the Government ([see 6.3](#)) on sample units produced with equipment and procedures normally used in production.

4.5.1 Sample size. The number of switches to be subjected to qualification inspection shall be as specified in [table II](#) and the [appendix A](#) of this specification.

4.5.2 Inspection routine. The sample shall be subjected to the inspections specified in [table II](#), in the order shown.

4.5.3 Failures. One or more failures shall be cause for refusal to grant qualification approval.

TABLE I. Materials inspection.

Material	Requirement paragraph
Plastic	3.4.2
Fungus	3.4.2.1
Rubber	3.4.3

MIL-DTL-8834J w/Amendment 1

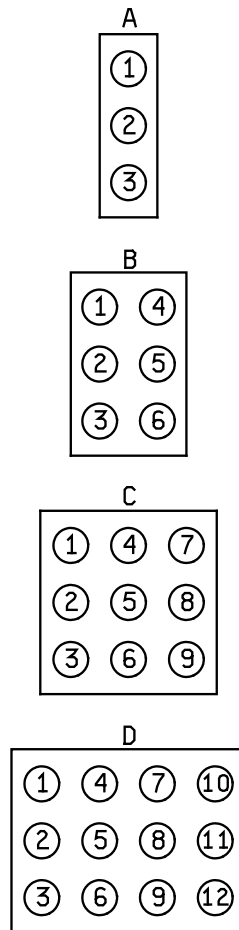

NOTE: All views are rear face of switch with keyway or flat down as applicable ([see 3.1](#)).

FIGURE 1. Terminal symbols and identification numbers.

MIL-DTL-8834J w/Amendment 1

4.5.4 Retention of qualification. To retain qualification, the contractor shall forward a report at 12-or 36-month intervals to the qualifying activity. The preparing activity shall establish the initial reporting date. The report shall consist of:

- a. A summary of the results of the tests performed for inspection of product for delivery, group A, indicating as a minimum the number of lots that have passed and the number that have failed. The results of tests of all reworked lots shall be identified and accounted for.
- b. The results of tests performed for periodic inspection, group B, including the number and mode of failures. The test report shall include results of all periodic inspection tests performed and completed during the reporting period. If the test results indicate nonconformance with specification requirements, and corrective action acceptable to the qualifying activity has not been taken, action may be taken to remove the failing product from the qualified products list.

Failure to submit the report within 30 days after the end of the reporting period may result in loss of qualification for the product. In addition to the periodic submission of inspection data, the contractor shall immediately notify the qualifying activity of any time during the reporting period that the inspection data indicates failure of the qualified product to meet the requirements of this specification.

In the event that no production occurred during the reporting period, a report shall be submitted certifying that the company still has the capabilities and facilities necessary to produce the item. If during 2 consecutive periods there has been no production, the manufacturer may be required, at the discretion of the qualifying activity, to submit the basic switches covered by the applicable MS ([see table IX](#)) to testing in accordance with the qualification inspection requirements.

4.6 Inspection requirements for category II switches. Inspection requirements shall be performed by the contractor, after award of contract and prior to production, in accordance with the ordering data ([see 6.2.2](#)).

4.6.1 Category II switches. Additional tests may be required to verify the deviations.

4.7 Conformance inspection.

4.7.1 Inspection of product for delivery. Inspection of product for delivery shall consist of group A inspection.

4.7.1.1 Inspection lot. An inspection lot shall consist of all switches that appear on the same MS military standard or military specification sheet and that are offered for delivery at one time. Momentary action switches shall form a separate lot.

4.7.1.2 Group A inspection. Group A inspection shall consist of the inspections specified in [table III](#). The inspections may be performed in any order, except dielectric withstanding voltage shall be performed after seal testing.

4.7.1.3 Sampling plan. Statistical sampling shall be in accordance with [table III](#) and [table IV](#). A randomly selected group(s) of samples is required for subgroups 1 and 2. For acceptance of the lot there shall be zero occurrences of defects.

4.7.1.3.1 Subgroup 1. A sample of parts shall be randomly selected in accordance with [table IV](#), subgroup 1 sampling plan.

4.7.1.3.2 Subgroup 2. A sample of parts shall be randomly selected in accordance with [table IV](#), subgroup 2 sampling plan.

4.7.1.4 Rejected lots. If an inspection lot is rejected, the lot shall be 100 percent inspected for the defects noted. The contractor may correct all of the defects or remove all of the defective units from the lot. The lot shall then be sampled again in accordance with [tables III](#) and [IV](#). For acceptance, there shall be zero occurrences of defects. Such lots shall be separate from new lots and shall be clearly identified as reinspected lots.

MIL-DTL-8834J w/Amendment 1

TABLE II Qualification inspection.

Inspection	Requirement paragraph	Test paragraph
<u>Group I (2 sample units)</u>		
Examination of product	3.1	4.8.1
Switching characteristics	3.6.3	4.8.4
Strength of terminals	3.6.4	4.8.5
Strength of actuating-lever pivot or lever stop	3.6.5	4.8.6
Strength of mounting bushing	3.6.6	4.8.7
Flammability	3.6.22	4.8.23
Examination of product <u>1/</u>	3.1, 3.4 through 3.5.9, 3.7, and 3.8	4.8.1
<u>Group II (2 sample units)</u>		
Examination of product	3.1	4.8.1
Marking permanency <u>2/</u>	3.7.1.1	4.8.24
Resistance to soldering heat	3.6.2	4.8.3
Switching characteristics	3.6.3	4.8.4
Mechanical endurance	3.6.7	4.8.8
Thermal shock	3.6.19	4.8.20
Sealing	3.6.20	4.8.21
Toggle seal (water) <u>2/</u>	3.6.20.1	4.8.21.1
Environmental seal test <u>2/</u>	3.6.20.2	4.8.21.2
Examination of product <u>1/</u>	3.1, 3.4 through 3.5.9, 3.7, and 3.8	4.8.1
<u>Group III <u>3/</u></u>		
Examination of product	3.1	4.8.1
Switching characteristics	3.6.3	4.8.4
Contact bounce (when specified, see 3.1)	3.6.8	4.8.9
Contact voltage drop	3.6.9	4.8.10
Electrical overload, endurance, and temperature rise <u>3/</u>	3.6.11	4.8.12
Overload	3.6.11	4.8.12.1
Resistive load (dc)	3.6.11	4.8.12.2
Inductive load (dc)	3.6.11	4.8.12.3
Lamp load (dc)	3.6.11	4.8.12.4
Resistive load (ac)	3.6.11	4.8.12.2
Inductive load (ac)	3.6.11	4.8.12.3
Lamp load (ac)	3.6.11	4.8.12.4
Temperature rise	3.6.11	4.8.12.6
Dielectric withstanding voltage <u>4/</u>	3.6.10	4.8.11
Examination of product <u>1/</u>	3.1, 3.4 through 3.5.9, 3.7, and 3.8	4.8.1

See footnotes of end of table.

MIL-DTL-8834J w/Amendment 1

TABLE II Qualification inspection - Continued.

Inspection	Requirement paragraph	Test paragraph
<u>Group IV (2 sample units)</u>		
Examination of product	3.1	4.8.1
Switching characteristics	3.6.3	4.8.4
Toggle ice	3.6.17	4.8.18
Sand and dust	3.6.18	4.8.19
Dielectric withstanding votlage	3.6.10	4.8.11
Sealing	3.6.20	4.8.21
Toggle seal (water) <u>2/</u>	3.6.20.1	4.8.21.1
Environmental seal test <u>2/</u>	3.6.20.2	4.8.21.2
Examination of product <u>1/</u>	3.1, 3.4 through 3.5.9, 3.7, and 3.8	4.8.1
<u>Group V (2 sample units)</u>		
Examination of product	3.1	4.8.1
Switching characteristics	3.6.3	4.8.4
Dielectric withstanding voltage	3.6.10	4.8.11
Explosion (not required for environmental seal)	3.6.21	4.8.22
Examination of product <u>1/</u>	3.1, 3.4 through 3.5.9, 3.7, and 3.8	4.8.1
<u>Group VI (2 sample units)</u>		
Examination of product	3.1	4.8.1
Switching characteristics	3.6.3	4.8.4
Life, dry circuit, low level, and intermediate current switching <u>5/</u>	3.6.11	4.8.12.5
Dielectric withstanding voltage	3.6.10	4.8.11
Examination of product <u>1/</u>	3.1, 3.4 through 3.5.9, 3.7, and 3.8	4.8.1
<u>Group VII (2 sample units)</u>		
Examination of product	3.1	4.8.1
Switching characteristics	3.6.3	4.8.4
Shock	3.6.13	4.8.14
Method I	3.6.13	4.8.14.1
Method II <u>2/</u>	3.6.13	4.8.14.2
Vibration, high frequency	3.6.14	4.8.15
Moisture resistance	3.6.16	4.8.17
Dielectric withstanding voltage	3.6.10	4.8.11
Sealing	3.6.20	4.8.21
Toggle seal (water) <u>2/</u>	3.6.20.1	4.8.21.1
Environmental seal test <u>2/ 6/</u>	3.6.20.2	4.8.21.2
Examination of product <u>1/</u>	3.1, 3.4 through 3.5.9, 3.7, and 3.8	4.8.1

See footnotes of end of table.

MIL-DTL-8834J w/Amendment 1

TABLE II Qualification inspection - Continued.

Inspection	Requirement paragraph	Test paragraph
<u>Group VIII (2 sample units)</u>		
Examination of product	3.1	4.8.1
Switching characteristics	3.6.3	4.8.4
Short circuit closure	3.6.12	4.8.13
Salt spray	3.6.15	4.8.16
Examination of product ^{1/}	3.1 , 3.4 through 3.5.9 , 3.7 , and 3.8	4.8.1
<u>Group IX (2 sample units)</u>		
Examination of product	3.1	4.8.1
Solderability	3.6.1	4.8.2
Examination of product ^{1/}	3.1 , 3.4 through 3.5.9 , 3.7 , and 3.8	4.8.1

^{1/} Only one sample unit from group I and one sample unit from group VIII shall be inspected for physical dimensions.

^{2/} Where applicable.

^{3/} Two switches will be tested at each voltage, current, and frequency specified ([see 3.1](#)). When more than six loads are specified, additional specimens shall be required. Only sample units subjected to resistive loads shall be tested for temperature rise.

^{4/} The dielectric withstanding voltage test following electrical endurance is not applicable to switches covered by MS military standard sheets that are approved before 1 January 1971.

^{5/} One additional specimen is required for one and two pole switches.

^{6/} For switches with integrated wire terminals, the terminal-sealing/fluid-immersion test shall be performed as specified on the applicable specification sheets or MS drawings ([see 3.1](#)).

TABLE III. Group A inspection.

Inspection	Requirement paragraph	Test method paragraph	Sampling plan
<u>Subgroup 1</u>			
Examination of product	3.1	4.8.1	See 4.7.1.3.1 1/
Material	3.4	4.3 and 4.8.1	
Design and construction	3.5	4.8.1	
Marking	3.7	4.8.1	
Workmanship	3.8	4.8.1	
<u>Subgroup 2</u>			
Sealing (as applicable)	3.6.20.2.2	4.8.21.2.2	See 4.7.1.3.2 1/
Switching characteristics	3.6.3	4.8.4	
Dielectric withstanding voltage	3.6.10	4.8.11	
Contact voltage drop	3.6.9	4.8.10	

^{1/} At the option of the contractor, documented in-process inspection may be used to satisfy the requirements provided that all of the contractor's in-process control data on these tests are made available to the Government upon request.

MIL-DTL-8834J w/Amendment 1

TABLE IV. Zero defect sampling plan.

Lot size	Minimum number of switches to be tested	
	Subgroup 1	Subgroup 2
1-4	All	All
5-12	5	All
13-50	5	13
51-90	7	13
91-150	11	13
151-280	13	20
281-500	16	29
501-1,200	19	34
1,201-3,200	23	42
3,201-10,000	29	50
10,001-35,000	35	60

4.7.2 Periodic inspection. Periodic inspection shall consist of group B. Except where the results of these inspections show noncompliance with the applicable requirements ([see 6.4](#)), delivery of products which have passed group A shall not be delayed pending the results of these periodic inspections.

4.7.2.1 Group B inspection. Group B inspection shall consist of the inspections specified in [table V](#) in the order shown.

4.7.2.1.1 Sampling plan. The sampling plan and test procedure shall be as specified in the [appendix A](#) to this specification. Group B inspection shall be completed in accordance with [table V](#) within each 3-year period after initial qualification. A manufacturer's normal quality control tests, production tests and environmental tests may be used to fulfill all or part of group B inspection; however all of group B inspection shall be completed as specified. Data used may be accumulated within the previous 24 months.

4.7.2.1.2 Disposition of sample units. Sample units subject to group B inspection shall not be delivered on the contract or order but shall be kept on hand until the next inspection period for submittal to the qualifying activity if so requested.

4.8 Methods of inspection.

4.8.1 Examination of product. Switches shall be examined to verify that the design, construction, marking, and workmanship are in accordance with the applicable requirements. Only two of the sample units shall be inspected for compliance with physical dimensions. This inspection shall be performed before any other test is performed on the sample units (see [3.1](#), [3.4](#), and [3.5](#)).

4.8.2 Solderability (applicable to solderable terminals, see 3.6.1). Switches shall be tested in accordance with [method 208 of MIL-STD-202](#). The following details and exceptions shall apply:

- a. Number of terminals to be tested: A minimum of one terminal of a closed contact per switch.
- b. Depth of immersion in molten solder: Terminals shall be immersed to the maximum extent possible.
- c. Examination of terminals: Method for evaluation of lugs and tabs shall apply.
- d. Dipping machine: Need not be used.

MIL-DTL-8834J w/Amendment 1

TABLE V. Group B inspection.

Inspection	Requirement paragraph	Test method paragraph
<u>Subgroup I (2 sample units)</u>		
Examination of product	3.1	4.8.1
Marking permanency <u>1/</u>	3.7.1.1	4.8.24
Mechanical endurance	3.6.7	4.8.8
Sealing	3.6.20	4.8.21
Toggle seal (water) <u>1/</u>	3.6.20.1	4.8.21.1
Environmental seal test <u>1/ 6/</u>	3.6.20.2	4.8.21.2
Examination of product <u>2/</u>	3.1, 3.4 through 3.5.9, 3.7, 3.8	4.8.1
<u>Subgroup II (2 sample units)</u>		
Examination of product	3.1	4.8.1
Shock	3.6.13	4.8.14
Method I	3.6.13	4.8.14.1
Method II <u>1/</u>	3.6.13	4.8.14.2
Salt spray	3.6.15	4.8.16
Examination of product <u>2/</u>	3.1, 3.4 through 3.5.9, 3.7, 3.8	4.8.1
<u>Subgroup III (2 sample units)</u>		
Examination of product	3.1	4.8.1
Electrical overload, endurance, and temperature rise	3.6.11	4.8.12
Overload	3.6.11	4.8.12.1
Resistive load (ac) <u>3/</u>	3.6.11	4.8.12.2
Temperature rise	3.6.11	4.8.12.6
Dielectric withstanding voltage	3.6.10	4.8.11
Examination of product <u>2/</u>	3.1, 3.4 through 3.5.9, 3.7, 3.8	4.8.1
<u>Subgroup IV (2 sample units)</u>		
Examination of product	3.1	4.8.1
Electrical overload and endurance	3.6.11	4.8.12
Overload	3.6.11	4.8.12.1
Inductive load (cc) <u>4/</u>	3.6.11	4.8.12.3
Dielectric withstanding voltage	3.6.10	4.8.11
Examination of product <u>2/</u>	3.1, 3.4 through 3.5.9, 3.7, 3.8	4.8.1
<u>Subgroup V (2 sample units)</u>		
Examination of product	3.1	4.8.1
Life, low level, dry circuit, and intermediate current switching <u>5/</u>	3.6.11	4.8.12.5
Examination of product <u>2/</u>	3.1, 3.4 through 3.5.9, 3.7, 3.8	4.8.1

See footnotes at end of table.

MIL-DTL-8834J w/Amendment 1

TABLE V. Group B inspection - Continued.

Inspection	Requirement paragraph	Test method paragraph
<u>Subgroup VI (2 sample units)</u>		
Examination of product	3.1	4.8.1
Sealing - toggle seal <u>1/</u>	3.6.20.1	4.8.21.1
Examination of product <u>2/</u>	3.1, 3.4 through 3.5.9, 3.7, 3.8	4.8.1
<u>Subgroup VII (2 sample units)</u>		
Examination of product	3.1	4.8.1
Sealing-environmental <u>1/ 6/</u>	3.6.20.2	4.8.21.2
Examination of product <u>2/</u>	3.1, 3.4 through 3.5.9, 3.7, 3.8	4.8.1
<u>Subgroup VIII (2 sample units)</u>		
Examination of product	3.1	4.8.1
Solderability <u>1/</u>	3.6.1	4.8.2
Examination of product <u>2/</u>	3.1, 3.4 through 3.5.9, 3.7, 3.8	4.8.1

1/ As applicable.

2/ Only one sample unit from group I and one sample unit from group III shall be inspected for physical dimensions.

3/ Test at 115 volts, 50 Hz, room temperature and pressure.

4/ Test at 28 V dc and altitude when applicable.

5/ One additional specimen is required for one and two pole switches.

6/ For switches with integrated wire terminals, the terminal-sealing/fluid-immersion test shall be performed as specified on the applicable specification sheets or MS drawings.

4.8.3 Resistance to soldering heat (applicable to solderable terminals, see 3.6.2). Switches shall be tested in accordance with [method 210 of MIL-STD-202](#). The following details shall apply:

- a. Number of terminals to be tested: A minimum of one terminal of a closed contact per switch.
- b. Depth of immersion in molten solder: Terminals shall be immersed to the maximum extent possible.
- c. Test condition letter: B.
- d. Cooling time prior to final examinations and measurements: Not applicable.
- e. Examinations and measurements:
 - (1) Before: None.
 - (2) After: Switches shall be operable and there shall be no evidence of internal deformation or other damage when opened at the conclusion of the test sequence.

4.8.4 Switching characteristics (see 3.6.3). Switching action (e.g., on-off or on-off-on) and circuitry shall be inspected for compliance with the applicable requirements ([see 3.1](#)). Circuit continuity shall be inspected using a 6-volt source and a maximum load of 100 milliamperes.

4.8.5 Strength of terminals (see 3.6.4). When mounted in accordance with [4.8.7](#), terminals shall be tested as specified herein. All terminals are to be tested, but any one terminal shall be tested in one direction only.

MIL-DTL-8834J w/Amendment 1

4.8.5.1 Solderable terminals. Solderable terminals shall be tested in accordance with [method 211 of MIL-STD-202](#). The following details and exceptions shall apply:

- a. Test condition letter: A.
- b. Applied force: 5 pounds.
- c. Direction of applied force:
 - (1) With the terminals vertical and pointing downward, the specified pull shall be applied directly downward.
 - (2) With the terminals horizontal, the specified pull shall be applied directly downward.
 - (3) With the terminal horizontal and rotated 90 degrees about their horizontal axis from the position in c(2), the specified pull shall be applied directly downward.

4.8.5.2 Screw-lug terminals. Screw-lug terminals shall be tested in accordance with [method 211 of MIL-STD-202](#). The following details and exceptions shall apply:

- a. Test condition letter: A.
- b. Applied force: 25 pounds.
- c. Direction of applied force:
 - (1) Parallel to the axis of the terminal screw.
 - (2) Perpendicular to the axis of the terminal screw.

4.8.5.3 Integrated wire terminals. Integrated wire terminals shall be subjected to a 5-pound pull for 5 to 10 seconds, in the following directions:

- a. With the long dimension of the terminal contact vertical, and the contact opening facing downward, specified pull shall be applied directly downward.
- b. With the long dimension of the terminal contact horizontal, the specified pull shall be applied directly downward.
- c. Two outboard terminals on each switch shall be tested. However, a terminal shall be tested only once in one direction.

4.8.5.4 Screw thread terminals. Screw-thread terminals shall be tested in accordance with [method 211 of MIL-STD-202](#), test condition letter E. The torque shall be applied in the direction which will tighten the screw.

MIL-DTL-8834J w/Amendment 1

4.8.6 **Strength of actuating-lever pivot and lever stop** ([see 3.6.5](#)). The switch shall operate mechanically and electrically at a maximum load of 6 V dc, 100 milliamperes after the following tests:

- a. A 25-pound load, except for b. below, shall be applied to the tip of the actuating level for 1-minute under each of the following conditions:
 - (1) Perpendicular to the lever axis and parallel to the line of lever travel at each end position of the lever. For lever-lock types, the test shall be conducted at each fixed position of the lever.
 - (2) Perpendicular to the lever axis and perpendicular to the line of travel at each lever position.
 - (3) Coaxial with the lever axis away from the lever pivot, throughout the entire range of lever travel.
 - (4) Coaxial with the lever axis end toward the lever pivot, throughout the entire range of lever travel. For lever-lock types, this test is only applicable to those changes in lever position which may be accomplished without lifting the lever from its detent position.
- b. For lever-lock types with external stops, a 35-pound load shall be used for test a(1) above.

4.8.7 **Strength of mounting bushing** ([see 3.6.6](#)). Bushing mounted switches shall be mounted on a metal panel using normal mounting means with the hardware specified on the applicable MS. A torque of 25 pound-inches shall be applied to the mounting nut on switches with 15/32 inch diameter bushings or larger and a torque of 15 pound-inches shall be applied to the mounting nut on smaller size bushings. If the unit has provision for an antirotational device, the mounted switch body shall be subjected to a torque of 5-pound-inches, with the nonturn device mounted on the switch in the normal manner.

4.8.8 **Mechanical endurance** ([see 3.6.7](#)). Unless otherwise specified ([see 3.1](#)), the switches shall be subjected to 40,000 cycles of operation. The following details shall apply (a. through g. for environmentally sealed switches only; b. through g. for toggle sealed switches):

- a. Unless otherwise specified ([see 3.1](#)), switches shall be maintained at a temperature of $-55^{\circ}\text{C} \pm 2^{\circ}\text{C}$ for a period of at least 2 hours with the contacts open. At the conclusion of this period, all "on" positions shall be tested using a pilot circuit with parameters of 28 V dc maximum and 100 milliamperes maximum. Failure to turn "on" on the first operation shall constitute failure.
- b. Unless otherwise specified ([see 3.1](#)), one half the cycles shall be at $-55^{\circ}\text{C} \pm 2^{\circ}\text{C}$ while the other half of the cycles shall be at $+71^{\circ}\text{C} \pm 2^{\circ}\text{C}$.
- c. A cycle shall be the movement of the toggle lever from one extreme position to the other extreme position and return to the original position.
- d. Cycling rate shall be 10 to 18 cycles per minute (cpm). At the manufacturer's option, a faster rate of cycling up to 60 cpm may be used.
- e. Lever-lock switch handles shall also be tested for 20,000 actuations, at room ambient conditions, by pulling the lever to its fully extended position and then permitting it to return to its fully retracted position without operation of the switches, at a maximum of 60 cpm.
- f. With the toggle lever in the unlocked position, lever-lock switches shall be tested with the toggle lever moving through all positions.
- g. Momentary switches shall return from their momentary position(s) solely by the internal mechanism of the switch.

MIL-DTL-8834J w/Amendment 1

4.8.9 Contact bounce (when specified, see 3.6.8). Photographic record of contact bounce shall be submitted for qualification and group B test approval. The duration of contact bounce shall be taken as the average of five consecutive readings on each contact pair. The contact bounce shall be determined by the use of the test circuit on [figure 2](#) and bounce time shall be measured as shown on [figure 2](#). Caution should be observed to be sure that the photographic records include not only the initial bounce but any secondary bounce if it exists.

4.8.10 Contact voltage drop (see 3.6.9). Switches shall be tested in accordance with [method 307 of MIL-STD-202](#); the following details shall apply:

- a. Measurements shall be made between the terminals of the contacts of the same pole forming a switching circuit. Measurements shall be made for each pole of multipole switches.
- b. Test current: 100 milliamperes.
- c. Open-circuit voltage: 2 to 6 V dc.
- d. Number of activations prior to measurement: 3.
- e. Number of test activations: 3
- f. Number of measurements per activation: 1.

4.8.11 Dielectric withstanding voltage (see 3.6.10). Switches shall be tested in accordance with [4.8.11.1](#) and [4.8.11.2](#), to which the following details and exceptions shall apply:

- a. [Method 301 of MIL-STD-202](#) shall be used.
- b. Duration of application of test voltage: One minute minimum for qualification and group B; 2 to 5 seconds for other tests.
- c. Points of application:
 - (1) Between mutually insulated parts (not applicable after electrical endurance tests).
 - (2) Between current-carrying parts and all noncommon exposed or grounded metal parts.
- d. Measurements shall be made for each lever position.
- e. Leakage or failure: Momentary flashover or leakage in excess of 500 microamperes shall constitute failure.
- f. Group A test shall be conducted at room ambient conditions only, and the potential shall be 1,800 V rms. For switches rated above 250 volts, the minimum test voltage shall be 240 percent of rated voltage plus 1,200 volts.
- g. Examination after test: Switches shall be examined for evidence of arcing, flashover, breakdown of insulation, or damage.

4.8.11.1 At atmospheric pressure. The following details shall apply:

- a. Test voltage: 1,500 V rms minimum. Switches rated above 250 volts shall be subjected to a minimum voltage of 1,000 V rms plus twice the rated voltage.
- b. 750 V rms minimum shall be used after electrical endurance tests between current-carrying parts and all noncommon exposed or grounded metal parts. Duration of application of test voltage: 1 minute minimum.
- c. In lieu of voltage and time in b. above, use 900 V rms for 2 to 5 seconds.

MIL-DTL-8834J w/Amendment 1

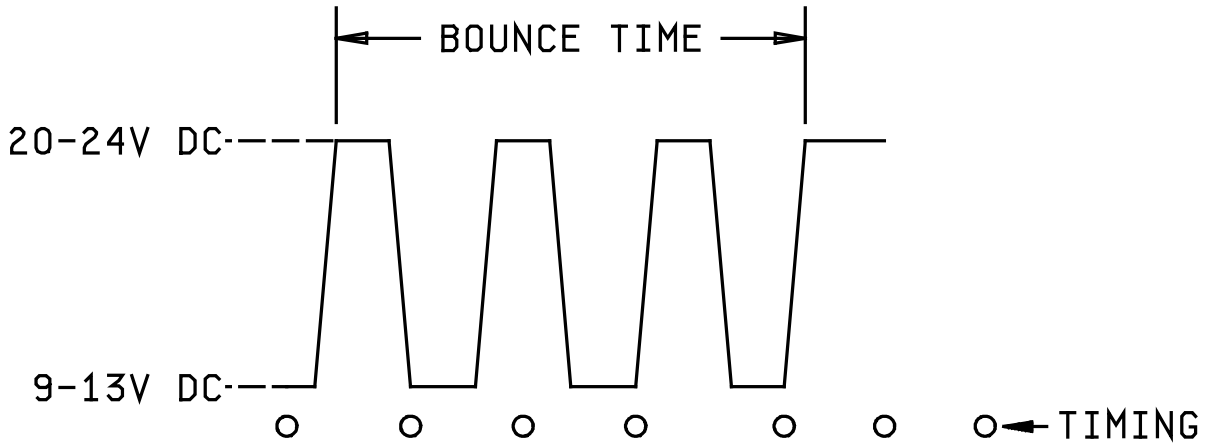

TYPICAL RECORDING OF CONTACT BOUNCE

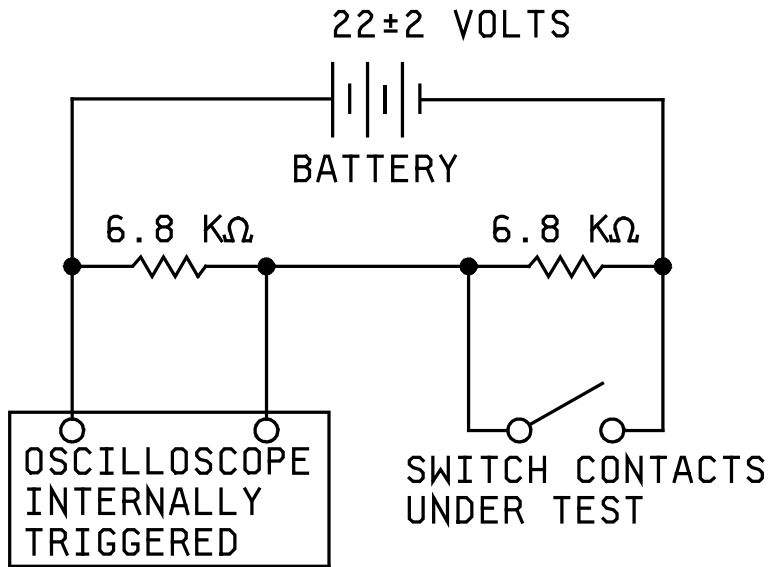

FIGURE 2. Test circuit for contact bounce.

MIL-DTL-8834J w/Amendment 1

4.8.11.2 At reduced barometric pressure. The following details shall apply:

- a. [Method 105 of MIL-STD-202](#) at 65,000 feet.
- b. Test voltage: 500 V rms minimum. Switches rated above 250 volts shall be subjected to a minimum voltage of 500 V rms plus twice the rated voltage.

4.8.12 Electrical overload, endurance, life, low level and intermediate current switches, and temperature rise (see 3.6.11). The following conditions and exceptions shall apply:

- a. Test switches shall be mounted by their normal mounting means against a metal plate. Insulators shall not be interposed between the switch case and the metal plate or between the metal actuator of the actuating machine and the switch toggle.
- b. The metal mounting plate, one side of the power supply, and the metal actuator of the actuating machine shall all be connected to a common ground through a 3 ampere fuse in accordance with [MIL-PRF-15160/2](#) characteristic A (F02A, 250 V, 3 A) (see [figure 3](#)). For direct current, the negative side of the power supply shall be grounded. The test switch shall be connected to the power source and test load using a 6 inch to 6 foot length of wire as specified in [table VI](#).
- c. The test voltage magnitude and electrical frequency shall be maintained within the tolerances specified when the test voltage is measured at the switch terminals. Monitor circuits shall be provided to detect failure or any pair of contacts to open or close their circuit in proper sequence and shall not shunt switch contacts or inductive components in the test circuit.
- d. One throw of each pole of the switch shall be connected to an independent test circuit meeting the specified conditions. Multipole switches are to be tested with a load per pole. All poles shall be connected to the same supply line, as shown in [figure 3](#). For double-throw switches, one half the switches shall be tested with the load circuit connected to one throw and the remaining half of the switches shall be tested with the load circuit connected to the other throw. The load switched by a switch contact shall be the same throughout the duration of the cycling.
- e. Switches shall be actuated at a frequency of 10 to 18 cpm and at a maximum velocity of 5 inches per second by a power driven actuator.
- f. During the overload test, the closed time of the switch shall be 0.5 second duration minimum during each cycle of operation. Unless otherwise specified ([see 3.1](#)), the endurance test duty cycle shall be a minimum of 25 percent on.
- g. Switches shall be subjected to the overload, and electrical tests specified in [table II](#).
- h. Overload and endurance tests shall be performed on the same pair of contacts using the same voltage and electrical frequency for both tests.
- i. Momentary switches shall return from their momentary position(s) solely by the internal mechanism of the switch.

4.8.12.1 Overload circuit. The switch shall make and break 150 percent of rated resistive load at the applicable voltage and electrical frequency for 50 cycles of operation at room conditions.

4.8.12.2 Resistive load (dc and ac). One half of the switches for test shall make and break the rated resistive load for 20,000 operating cycles while at room pressure and a temperature of $71^{\circ}\text{C} \pm 2^{\circ}\text{C}$ (or other temperature as specified). Unless otherwise specified ([see 3.1](#)), the other half of the switches for test shall make and break the rated resistive load for 20,000 operating cycles while at room temperature and a pressure equivalent to 65,000 feet altitude.

4.8.12.3 Inductive load (dc and ac). Unless otherwise specified ([see 3.1](#)), one half of the switches shall make and break the rated inductive load for 20,000 operating cycles while at a pressure equivalent to 65,000 feet altitude and at room temperature. The other half shall make and break rated inductive load for 20,000 operating cycles at room ambient. The ac inductive circuit shall have a power factor of 75-80 percent.

MIL-DTL-8834J w/Amendment 1

TABLE VI. Wire size and circuit breaker or fuse designation.

Amperes	SAE-AS50861 wire sizes	Circuit breaker or fuse
3.0 or less	20	The size of the circuit breaker or fuse shall be equivalent to the test current. Fuses shall conform to MIL-PRF-15160/2 . Circuit breakers shall conform to SAE-AS58091 .
5.0	20	
7.5	18	
10.0	18	
15.0	18	
18.0	16	
20.0	16	
25.0	14	
30.0	14	
40.0	12	
60.0	10	
80.0	8	
175.0	2	

4.8.12.4 Lamp-load circuit (ac and dc). Switches shall be subjected to 20,000 operating cycles when wired into a circuit having rated steady state lamp-load current at the applicable rated voltage. For ac lamp loads, only tungsten filament lamps having a wattage not exceeding 200 watts at the specified voltage shall be used to make up the load. For dc lamp loads, tungsten filament lamps having a nominal wattage of 25 to 50 watts at the specified voltage shall be used to make up the load. A minimum cooling period of 15 seconds shall be allowed between successive operations of the lamps. At the option of the manufacturer, a synthetic lamp load may be used for this test. The synthetic lamp shall consist of making 10 times the rated lamp load and breaking the rated lamp load. The duration of the 10 times inrush current shall be 0.015 second, minimum.

4.8.12.5 Life, dry circuit, low-level, and intermediate-current switching. Unless otherwise specified ([see 3.1](#)), single-pole switches shall be connected to the loads specified herein in the sequence shown. One pole of each multipole switch shall be connected to rated resistive load at 28 V dc. The other poles shall be connected to the loads specified herein in the sequence shown. Contacts subjected to these tests shall not have been electrically loaded prior to these tests.

<u>Circuit or pole no.</u>	<u>Loads</u>
1	10 milliamperes resistive load at 30 mV
2	5 percent rated resistive load at 28 V dc
3	3 percent rated inductive load at 28 V dc

The switches shall be operated for 20,000 operations on these loads at a rate of 10 to 12 operations per minute in an ambient temperature of 71°C ± 2°C.

4.8.12.6 Temperature rise. Each pole of the switch shall be connected in a circuit carrying the rated resistive endurance test current at any convenient ac or dc voltage. At the end of a one-hour period the terminal temperature rise, at a point adjacent to the insulating medium, shall be determined by means of appropriate thermocouples consisting of No. 28-32 AWG iron-constantan. This test shall be performed on the same switch contacts previously subjected to the overload and electrical endurance test. During this test, switches shall be mounted 6 inches apart on a .062 inch thick steel panel 6 inches wide in still air.

MIL-DTL-8834J w/Amendment 1

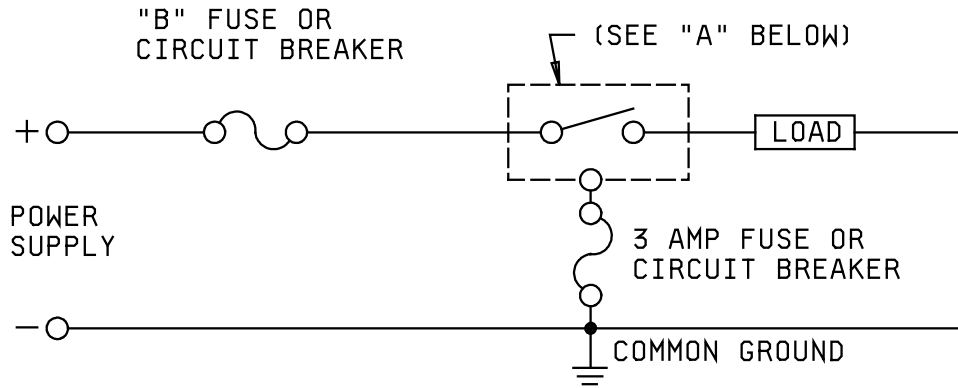

TEST SET-UP FOR SINGLE POLE SWITCHES

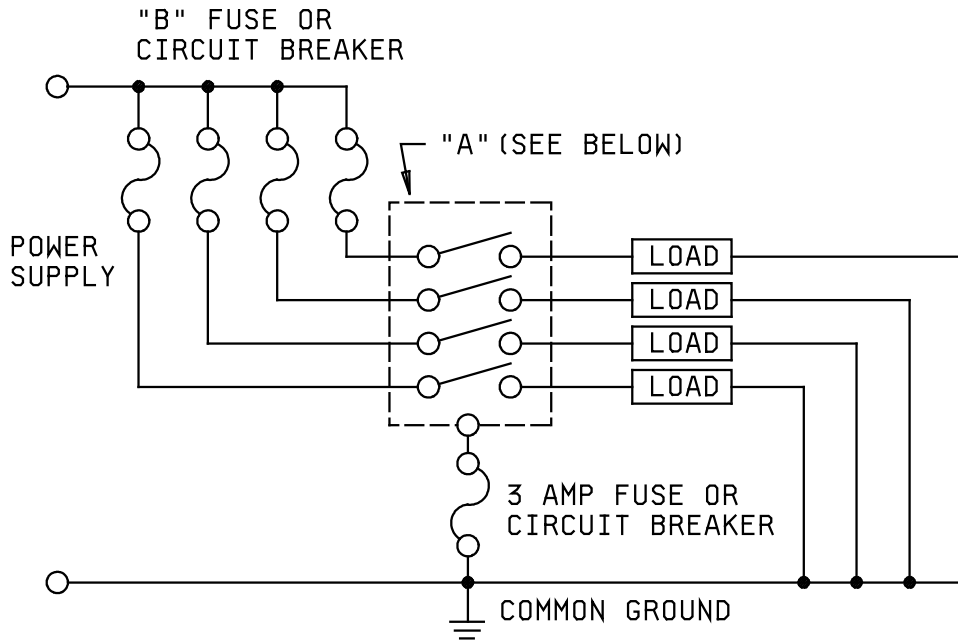

TEST SET-UP FOR MULTIPOLE SWITCHES

"A" metal mounting plate and metal actuator of actuating machine.
 "B" see [table VI](#) for proper fuse or circuit breaker.

FIGURE 3. Test set-up for electrical endurance test.

MIL-DTL-8834J w/Amendment 1

4.8.13 Short circuit closure (see [3.6.12](#)). The switch shall be inserted in a circuit calibrated to supply current equal to 60 times the rated resistive load at the lowest rated dc voltage specified (see [3.1](#)). The switch shall be connected in series by 1-foot lengths of wire to a thermal-type circuit breaker or a fuse in accordance with [figure 4](#) and [table VI](#). The wire shall be as specified in [SAE-AS50861](#) and [table VI](#) determined by the rated resistive load of the switch (see [3.1](#)). If the rated load of the switch does not coincide with a wire size, the next larger wire size shall be used. The terminals shall be in accordance with [SAE-AS7928](#). The circuit breaker shall be in accordance with [SAE-AS58091](#) and fuses shall be in accordance with [MIL-PRF-15160/2](#), or equivalent. If the rated load of the switch does not coincide with a circuit breaker or fuse current rating, the next larger breaker or fuse size shall be employed. Calibration shall be made without the circuit breaker (or fuse), test switch, or switch leads in the circuit. The calibrated circuit shall be closed by the switch under test and, after the circuit breaker or fuse interrupts the circuit, the test switch shall be manually opened by means of the toggle lever. This procedure shall be repeated 10 times. After each closure, the operating lever shall be returned manually to the "off" position, and the switch contacts shall be checked for proper opening by any suitable continuity test method. The circuit breaker shall be reset or the fuse replaced after each closure. A minimum of 2 minutes shall elapse between successive closure operations of the test switch. For double-throw switches, one-half of the switches shall be tested in one position and the remaining half shall be tested in the other position. Only one pole of multiple pole switches need be tested.

4.8.14 Shock (see [3.6.13](#)). Switches shall be tested in accordance with [4.8.14.1](#), or when specified (see [3.1](#)) in accordance with [4.8.14.2](#).

4.8.14.1 Method I. Switches shall be tested in accordance with [method 213 of MIL-STD-202](#), test condition I. The following details and exceptions shall apply:

- a. Contacts shall be monitored in accordance with [method 310 of MIL-STD-202](#).
- b. Switches shall be mounted using normal mounting means to a sufficient mass in each of its three perpendicular axes in turn. Half of the switches shall be tested in one lever position and the other half of the switches shall be tested in the alternate lever position.
- c. Electrical load conditions: The electrical load shall consist of the monitor circuit only.
- d. Measurement during shock: Switch contact stability shall be continuously monitored during shock. If more than one contact pair is being monitored simultaneously by one chatter indicator, open contact pairs shall be connected in parallel and closed contact pairs shall be connected in series during this test. In event of indication of a contact opening greater than specified, the test shall be modified by applying successive identical blows in the same plane to monitor contacts, switch by switch, to determine whether a switch is defective.
- e. Measurements after shock: Switches shall be inspected for switching characteristics (see [4.8.4](#)).
- f. Examination after test: Switches shall be examined for evidence of broken, deformed, displaced, or loose parts.

4.8.14.2 Method II (when specified). Switches shall be tested in accordance with [method 207 of MIL-STD-202](#). The following details and exceptions shall apply:

- a. Mounting: Mounting shall be as specified in [4.8.14.1b](#).
- b. Measurements during shock: Switch-contact stability shall be monitored simultaneously by one chatter indicator, open contact pairs shall be connected in parallel and closed contact pairs shall be connected in series during this test. In the event of indication of a contact opening greater than 20 milliseconds, the test shall be modified by applying successive identical blows in the same plane to monitor contacts, switch by switch, to determine which switches are defective.
- c. Measurements after shock: Switches shall be inspected for switching characteristics (see [4.8.4](#).)
- d. Examination after test: Switches shall be examined for evidence of broken, deformed, displaced, or loose parts.

MIL-DTL-8834J w/Amendment 1

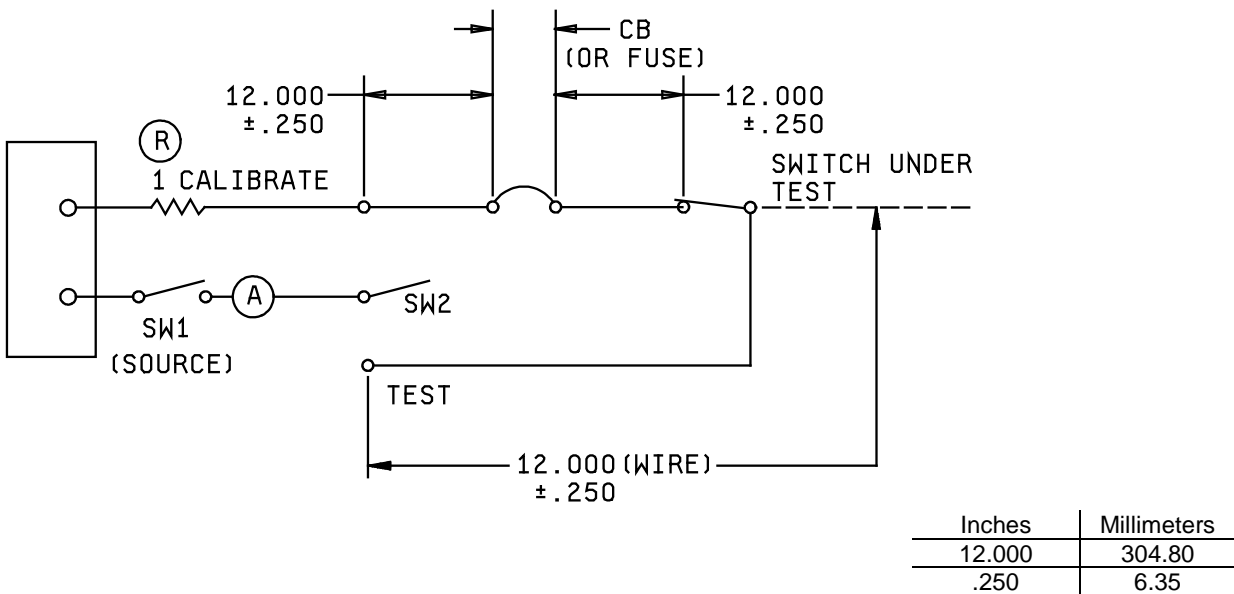

NOTES:

1. Dimensions are in inches.
2. Metric equivalents are in parenthesis.
3. Metric equivalents (to the nearest .01 mm) are given for general information only.

FIGURE 4. Circuit diagram for short-circuit test.

4.8.15 Vibration, high frequency (see 3.6.14). Switches shall be tested in accordance with [method 204 of MIL-STD-202](#). The following details and exceptions shall apply:

- a. Contact chatter shall be monitored in accordance with [method 310 of MIL-STD-202](#).
- b. Test condition letter: D, except sweep cycle shall be performed two times in each of three mutually perpendicular directions.
- c. Tests and measurements prior to vibration: Not applicable.
- d. Mounting: Switches shall be rigidly mounted by their normal mounting means on a rigid metal panel. The mounting fixture shall be free from resonance over the test frequency range. Half of the switches shall be tested in one lever position and the other half of the switches shall be tested in the alternate lever position.
- e. Electrical load conditions: The electrical load shall consist of the monitor circuit only.
- f. Measurements during vibration: Switch contact stability shall be continuously monitored during vibration. If more than one contact pair is being monitored simultaneously, open contact pairs may be connected in parallel and closed contact pairs may be connected in series during this test. In the event of indication of a contact opening or closure greater than specified, the test may be modified so that switches may be individually tested to determine if a switch is defective. Switches shall be observed for critical resonant frequencies. Resonant endurance tests shall be conducted for 15-minute periods at each critical resonant frequency found. If a change in resonant frequency occurs during testing, the frequency of vibration shall be adjusted to follow the change.
- g. Measurements after vibration: Switching characteristics (see 4.8.4).
- h. Examination after test: Switches shall be examined for change in actuated position and evidence of broken, deformed, displaced, or loose parts.

MIL-DTL-8834J w/Amendment 1

4.8.16 Salt spray (see 3.6.15). Switches shall be tested in accordance with [method 101, MIL-STD-202](#). The following details and exceptions shall apply:

- a. Test condition B.
- b. Treatment after test: Within 10 minutes after test, switches shall be washed for 5 minutes under running water not warmer than 38°C, accompanied by slight brushing, then dried for 6 hours in a force-draft oven at 50°C to 60°C.
- c. Following the drying period: The switches shall be examined for warping, cracking, or other damage. Environmentally sealed switches shall be subjected to 50 cycles of operation making and breaking the rated resistive current at the lowest rated dc voltage specified (see 3.1).

4.8.17 Moisture resistance (see 3.6.16). Switches shall be tested in accordance with [method 106 of MIL-STD-202](#). The following details shall apply:

- a. Mounting: By normal mounting means on a noncorrosive metal panel positioned 15 degrees from the vertical. One half of the switches shall be toggle mounted with toggle lever up and the other half with the toggle lever down. The mounting panel shall have appropriate mounting holes so that switches are at least 1 inch apart.
- b. Polarization: During steps 1 to 6 inclusive, a dc potential of 100 volts shall be applied between current-carrying parts and panel. Negative polarity shall be applied on the panel. Switches shall be monitored for electrical failures; a switch with a leakage current in excess of 1 milliamperes shall be considered a failure. Steps 7a and 7b are not applicable.
- c. Final measurements: Following a 24-hour period at room ambient conditions, switching characteristics shall be measured as specified in [4.8.4](#). Switches shall be examined for evidence of breaking, spalling, cracking, or loosening of terminals.
- d. Water: Steam, distilled, or de-ionized shall be used.

4.8.18 Toggle ice (see 3.6.17). The open end of the toggle sleeve shall be filled with water and the switch subjected to an ambient temperature of -55°C or below for a one-hour period. Then while still at ambient temperature, the switch shall be operated, breaking the ice. This test shall be conducted with the toggle lever in each position. The switch shall then be examined for evidence of mechanical damage.

4.8.19 Sand and dust (see 3.6.18). Switches shall be tested in accordance with [method 110 of MIL-STD-202](#). The following details and exception apply:

- a. Delete steps 2 and 3.
- b. Air velocity: 300 ± 200 feet per minute. During the test, the switches shall be mechanically operated for 2,500 cycles. The cycling rate shall be 10 to 18 cycles of operation per minute. The switch shall then be tested for mechanical and electrical operation, using a pilot lamp circuit or equivalent.

4.8.20 Thermal shock (see 3.6.19). Switches shall be tested in accordance with [method 107 of MIL-STD-202](#). The following details shall apply:

- a. Test condition: A.
- b. Measurements before and after cycling: Not applicable.
- c. Examination after test: Switches shall be examined for mechanical and electrical damage, loosening of rivets or other fastening devices, and electrical continuity.

MIL-DTL-8834J w/Amendment 1

4.8.21 Sealing (see 3.6.20).

4.8.21.1 Toggle seal (water) (applicable to toggle sealed switches only) (see 3.6.20.1). Switches shall be tested in accordance with [4.8.21.1.1](#) or when specified ([see 3.1](#)), in accordance with [4.8.21.1.2](#).

4.8.21.1.1 Method I. The open end of the mounting sleeve shall be gradually subjected to water pressure of 6.5 ± 0.5 pounds per square inch. While submerged, the switch shall be operated for 20,000 operations at a rate of 10 to 12 operations a minute. A panel seal in accordance with [MIL-DTL-5423/16](#) should be used to seal the sleeve-panel opening during this test. Switches shall then be examined to determine if water has entered the interior of the switches.

4.8.21.1.2 Method II (when specified). Switches shall be subjected to a 0.5 inch +0.25, -0 inch head of water above the top of the bushing. While subjected to the head of water, they shall be tested in the following sequence:

- a. 5 minutes static with the lever in any position.
- b. 5 complete normal operations.
- c. 5 minutes static with the lever in any position.

Switches shall then be examined to determine if water has entered their interiors.

4.8.21.2 Environmental seal test.

4.8.21.2.1 Temperature cycling submersion (applicable for qualification and group B tests only) (see 3.6.20.2.1). Unless otherwise specified ([see 3.1](#)), the switches shall be completely submerged in ethylene glycol in accordance with [ASTM E1119](#), at a temperature of 71°C ± 2°C, and each pole connected to a 0.1-ampere resistive load at the specified dc power supply voltage(s). The switches shall then be operated at a rate of 10 to 12 operations per minute for 20,000 operations; switches shall be constantly monitored for proper contact action. At the end of the second hour, the temperature of the ethylene glycol shall be reduced to -18°C ± 2°C and held at that temperature until the end of the fourth hour, at which time it shall be returned to 71°C ± 2°C. This 4-hour cycle shall be repeated throughout the test. The temperature change shall be completed within 10 minutes in each case. Switches shall be examined for mechanical and electrical failure. Immediately following the test, the switches shall be washed in clear water and dried by subjecting them to room ambient conditions for 4 hours. Switches shall then be subjected to the contact voltage drop test ([see 4.8.10](#)) and a dielectric withstanding voltage test of 1,000 volts ([see 4.8.11](#)).

4.8.21.2.2 Leakage test mass spectrometer (applicable for group A tests only) (see 3.6.20.2.2). Switches shall be tested in accordance with [method 112 of MIL-STD-202](#). The following details and exception shall apply:

- a. Test condition C: Procedure III.
- b. Leakage rate sensitivity 1×10^{-8} atmospheric cm^3/s during the exposure to helium atmosphere between the interior and exterior of the switches under test. Test conditions A and B for gross leak not applicable.

4.8.22 Explosion (toggle seal only) (see 3.6.21). Switches shall be tested in accordance with [method 109 of MIL-STD-202](#). The following detail shall apply:

Mechanical and electrical load: Switches shall be operated at their maximum rated dc inductive current ([see 3.1](#)).

MIL-DTL-8834J w/Amendment 1

4.8.23 Flammability (see 3.6.22). Switches shall be tested in accordance with [method 111 of MIL-STD-202](#). The following details and exceptions apply:

- a. Specimens are mounted so axis of bushing is horizontal.
- b. One-half of the specimens are to be tested with the keyway up; the other half shall have the keyway 90° from the up position.
- c. Specimens shall be tested without terminal hardware.
- d. Direction of the flame: Horizontal.
- e. The point of impingement of the applied flame: The backside of switch (opposite of toggle lever) as close to the middle as possible.
- f. Allowable time for burning of visible flame on the specimen is:
 - (1) Miniature switch: 90 seconds.
 - (2) Large switch: 60 seconds.

4.8.24 Marking permanency (applicable to switches with printed circuit board terminals, see 3.7.1.1). Switches shall be tested in accordance with [method 215 of MIL-STD-202](#). Only the marked portion of the switch (see 3.7.1) shall be tested.

5. PACKAGING

5.1 Packaging. For acquisition purposes, the packaging requirements shall be as specified in the contract or order (see 6.2). When packaging of materiel is to be performed by DoD or in-house contractor personnel, these personnel need to contact the responsible packaging activity to ascertain packaging requirements. Packaging requirements are maintained by the Inventory Control Point's packaging activities within the Military Service or Defense Agency, or within the military service's system commands. Packaging data retrieval is available from the managing Military Department's or Defense Agency's automated packaging files, CD-ROM products, or by contacting the responsible packaging activity.

6. NOTES

(This section contains information of a general or explanatory nature that may be helpful, but is not mandatory.)

6.1 Intended use. Switches furnished under this specification are intended for use in circuits with ratings no lower than the life, low current level, dry circuit switching requirements of [3.6.11](#).

6.2 Acquisition requirements. Acquisition documents must specify the following:

- a. Title, number and date of the specification.
- b. ASSIST Online database at <https://assist.daps.dla.mil/> should be cited in the solicitation, and if required, the specific issue of individual documents referenced (see 2.1).
- c. Packaging requirements (see 5.1).

6.2.1 Category I switches.

- a. National Stock Number (NSN).
- b. Switch, toggle.
- c. MS PIN along with document number and data (see 3.1).

MIL-DTL-8834J w/Amendment 1

- d. Basic document and date.
- e. Amendments, if applicable.
- f. Packaging requirements ([See 5.1](#)).
- g. Whether mounting or terminal hardware is not to be furnished.

6.2.2 Category II switches. (Available manufacturing test data showing compliance may be substituted as meeting these requirements at option of acquiring activity. A copy of the drawing furnished under g. including the description of the variations from the specification sheet, should be sent to the preparing activity as listed on the individual specification sheet

- a. National Stock Number
- b. Switch, toggle.
- c. MS number along with document number and date of similar category I switch.
- d. Basic document, date, and amendment, if applicable.
- e. Statement that switch is category II.
- f. Manufacturer's PIN of modified switch.
- g. Details of the variations from the MS military standard sheet.
- h. Inspection requirements: (To verify variations from category I switches).
 - (1) Tests to be performed (if any).
 - (2) The laboratory at which inspection is to be performed.
 - (3) Samples and submission of data, if other than that specified.
- i. Packaging requirements ([see 5.1](#)).

6.3 Qualification. With respect to products requiring qualification, awards will be made only for products which are, at the time of award of contract, qualified for inclusion in Qualified Products List (QPL) whether or not such products have actually been so listed by that date. The attention of the contractors is called to these requirements, and manufacturers are urged to arrange to have the products that they propose to offer to the Federal Government tested for qualification in order that they may be eligible to be awarded contracts or orders for the products covered by this specification. Information pertaining to qualification of products may be obtained via email to vqp.chief@dla.mil or from the Defense Supply Center Columbus, Attn: DSCC-VQP, 3990 East Broad Street, Columbus, OH 43213-1199.

6.4 Noncompliance. If a sample fails to pass group B inspection, the manufacturer should notify the qualifying activity and the cognizant inspection activity of such failure and take corrective action on the materials or processes, or both, as warranted, and on all units of product which can be corrected and which were manufactured under essentially the same conditions with essentially the same materials, processes, and which are considered subject to the same failure. Acceptance and shipment of the product should be discontinued until corrective action, acceptable to the qualifying activity has been taken. After the corrective action has been taken, group B inspection should be repeated on additional sample units (all inspection, or the inspection which the original sample failed, at the option of the qualifying activity.) Group A inspection may be reinstated; however, final acceptance and shipment should be withheld until the group B inspection has shown that the corrective action was successful. In the event of failure after reinspection, information concerning the failure should be furnished to the cognizant inspection activity and the qualifying activity.

6.5 Bushing and panel seals. Boots, when required, should be in accordance with [MIL-DTL-5423](#). Panel seals, when required, should be in accordance with [MIL-DTL-5423/16](#).

MIL-DTL-8834J w/Amendment 1

6.6 Switch guards. When switch guards are required, they should be in accordance with [MIL-DTL-7703](#).

6.7 Definitions.

6.7.1 Snap-action positive break. Snap-action positive break is a switch design in which the linkage between the actuator and movable contacts is a combination of a resilient linkage and direct mechanical linkage such that should the resilient member become fully compressed without moving the contacts, a direct mechanical linkage will override the resilient linkage to insure positive break.

6.7.2 Dry circuit. A dry circuit is an electrical circuit in which its current and voltage values are so small that when switch contacts are subjected to this electrical load, their contact resistance does not change.

6.8 Intermetallic contact. The finishing of metallic areas to be placed in intimate contact by assembly presents a special problem, since intermetallic contact of dissimilar metals results in electrolytic couples which promote corrosion through galvanic action. To provide the required corrosion protection, intermetallic couples are restricted to those permitted by [table VII](#). [Table VII](#) shows metals and alloys (or plates) by groups which have common electromotive forces (EMF) within 0.05 volt when coupled with a saturated calomel electrode in sea-water at room ambient temperatures. All members of a group are considered as completely compatible, one with the other. Compatible couples between groups have been specified in [table VII](#) based on a potential difference of 0.25 volt maximum. To simplify any arithmetic involved, [table VII](#) shows, in addition to EMF against calomel electrode, a derived "anodic index" with group 1 (gold) as 0 and group 18 (magnesium) as 175. Subtraction of a lower group anodic index gives the EFM difference in hundredths of a volt.

6.8.1 Groups. [Table VII](#) sets up 18 primary groups. It may be noted that neither the metallurgical similarity or dissimilarity of metals is the parameter for selection of compatible couples. All members within a group, regardless of metallurgical similarity, are considered inherently nonsusceptible to galvanic action when coupled with any member within the group; for example, such dissimilar metals as platinum and gold. Similarly, such basically dissimilar alloys as austenitic stainless steel, silver-solder, and low brass (all members of group 5) are inherently nonsusceptible when coupled together.

6.8.2 Compatibility graphs. Permissible couple series are shown in [table VII](#), by the graphs at the right. Members of groups connected by lines will form permissible couples. A o indicates the most cathode member of each series, a • an anodic member, and the arrow indicates the anodic direction.

6.8.3 Selection of compatible couples. Proper selection of metals in the design of equipment will result in fewer intermetallic contact problems. For example, for sheltered exposure, neither silver nor tin require protective finishes. However, since silver has an anodic index of 15 and tin 65, the EMF generated as a couple is 0.50 volt, which is not allowable by [table VII](#). In this case, other metals or plates will be required. It should be noted that, in intermetallic couples, the member with the higher anodic index is anodic to the member with the lower anodic index and will be susceptible to corrosion in the presence of an electrolytic medium. If the surface area of the cathodic part is significantly greater than that of the anodic part, the corrosive attack on the contact area of the anodic part may be greatly intensified. Material selection for intermetallic contact parts, therefore, should establish the smaller part as the cathodic member of the couple, whenever practicable.

6.8.4 Plating. When base metals intended for intermetallic contact form couples not allowed by [table VII](#), they are to be plated with those metals which will reduce the potential difference to that allowed by [table VII](#).

MIL-DTL-8834J w/Amendment 1

TABLE VII. Compatible couples (see y). 1/

GROUP NO.	Metallurgical category	EMF (volt)	Anodic Index (0.01v)	Compatible coupler
1	Gold, solid and plated; gold-platinum alloys; wrought platinum (most cathodic)	+0.15	0	○
2	Rhodium plated on silver-plated copper	+0.05	10	●
3	Silver, solid or plated; high silver alloys	0	15	○
4	Nickel, solid or plated; monel metal, high nickel-copper alloys	-0.15	30	●
5	Copper, solid or plated; low brasses or bronzes; silver solder; German silver; high copper-nickel alloys; nickel-chromium alloys; austenitic corrosion-resistant steels	-0.20	35	○
6	Commercial yellow brasses and bronzes	-0.25	40	●
7	High brasses and bronzes; naval brass; muntz metal	-0.30	45	○
8	18 percent chromium type corrosion-resistant steels	-0.35	50	●
9	Chromium, plated; tin, plated; 12 percent chromium type corrosion-resistant steels	-0.45	60	○
10	Tin-plated;terneplate; tin-lead solder	-0.50	65	●
11	Lead, solid or plated; high lead alloys	-0.55	70	○
12	Aluminum, wrought alloys of the duralumin type	-0.60	75	●
13	Iron, wrought, gray, or malleable; plain carbon and low alloy steels, armco iron	-0.70	85	○
14	Aluminum, wrought alloys other than duralumin type; aluminum, cast alloys of the silicon type	-0.75	90	●
15	Aluminum, cast alloys other than silicon type; cadmium, plated and chromated	-0.80	95	○
16	Hot-dip-zinc plate; galvanized steel	-1.05	120	●
17	Zinc, wrought; zinc-base die-casting alloys; zinc, plated	-1.10	125	○
18	Magnesium and magnesium-base alloys, cast or wrought (most anodic)	-1.60	175	●

1/ Compatible couples: potential difference of 0.25 volt maximum between groups.

6.8.5 Tin whisker growth. The use of alloys with tin content greater than 97 percent, by mass, may exhibit tin whisker growth problems after manufacture. Tin whiskers may occur anytime from a day to years after manufacture and can develop under typical operating conditions, on products that use such materials. Conformal coatings applied over top of a whisker-prone surface will not prevent the formation of tin whiskers. Alloys of 3 percent lead, by mass, have shown to inhibit the growth of tin whiskers. For additional information on this matter, refer to [ASTM-B545](#) (Standard Specification for Electrodeposited Coatings of Tin).

MIL-DTL-8834J w/Amendment 1

6.9 Internal standardization agreement. Certain provisions ([3.1](#) and [3.5.6](#)) of this specification are the subject of international standardization agreement ASCCAS 12/16A. When amendment, revision, or cancellation of this specification is proposed which will affect or violate the international agreement concerned, the preparing activity will take appropriate reconciliation action through international standardization offices, if required.

6.10 Environmentally preferable material. Environmentally preferable materials should be used to the maximum extent possible to meet the requirements of this specification. As of the dating of this document, the U.S. Environmental Protection Agency (EPA) is focusing efforts on reducing 31 priority chemicals. The list of chemicals and additional information is available on their website at <http://www.epa.gov/osw/hazard/wastemin/priority.htm>. Included in the EPA list of 31 priority chemicals are cadmium, lead, and mercury. Use of these materials should be minimized or eliminated unless needed to meet the requirements specified herein (see Section 3).

6.11 Subject term (key word) listing.

Dry circuit
Environmentally Sealed
Low level
Power switching
Snap action

6.12 Changes from previous issue. The margins of this specification are marked with vertical lines to indicate where modifications from this amendment were made. This was done as a convenience only and the Government assumes no liability whatsoever for any inaccuracies in these notations. Bidders and contractors are cautioned to evaluate the requirements of this document based on the entire content irrespective of the marginal notations.

MIL-DTL-8834J
APPENDIX APROCEDURE FOR QUALIFICATION INSPECTION,
AND MOUNTING AND TERMINAL HARDWARE

A.10. SCOPE

A.10.1 Scope. This appendix details the procedure for submission of samples for qualification and group B inspection of toggle switches covered by this specification. This appendix also lists mounting and terminal hardware used with toggle switches covered by this specification. Mounting and terminal hardware should be of the following design and construction as specified ([see 3.1](#)). This appendix is a mandatory part of the specification. The information contained herein is intended for compliance.

A.20. Samples.

A.20.1 Qualification. For qualification inspection, the sample size shall be as specified in [table II](#) and the tests shall be performed in the sequence shown.

A.20.1.1 Single submission. A sample consisting of the required number of specimens of each switch shall be submitted. Qualification shall be restricted to the type submitted.

A.20.1.2 Group submission. A sample consisting of the required number of specimens of each basic switch listed in [table A-I](#) shall be submitted and shall be subjected to the qualification test sequence of [table II](#) in the order shown. In addition, two specimens of each of the other switches listed in [table A-I](#) shall be submitted and shall be subjected to the examination of product and switching characteristics test of [table II](#).

A.20.2 Group B inspection. Sample units shall be selected at random from lots that have passed group A inspection.

A.20.2.1 Single submission. The sample size shall be as specified in [table V](#) and the tests shall be performed in the order shown.

A.20.2.2 Group submission. A sample consisting of the required number of specimens of each basic switch listed in [table A-I](#) shall be subjected to the test sequence of [table V](#) in the order shown. In addition, two specimens of each of the other switches listed in [table A-I](#) shall be submitted and shall be subjected to the examination of product and switching characteristic test of [table V](#). If the basic switches of a group are not in production at the time of selection of samples, other switches of the same group may be submitted, but maintained action switches shall not be substituted for momentary action switches.

MIL-DTL-8834J
w/Amendment 1
APPENDIX A

TABLE A-I. Group submission for qualification tests and extent of approval.

Group	Basic switches	Other switches	Extent of approval
1	MS25306-212 and MS25306-272	MS25306-232 MS25306-302	MS25306-212 through MS25306-312
2	MS25307-212 and MS25307-272	MS25307-232 MS25307-302	MS25307-212 through MS25307-312
3	MS25308-212 and MS25308-272	MS25308-232 MS25308-302	MS25308-212 through MS25308-312
4	MS21026-211 and MS21026-271	MS21026-231	MS21026-211 -221 -271 -231 -281 -241 -311
5	MS21027-211 and MS21027-271	MS21027-231	MS21027 -211 -271 -381 -221 -281 -231 -311 -241 -371
6	MS24612-212 and MS24612-272	MS24612-232 MS24612-302	MS24612-212 through MS24612-312
7	MS24613-212 and MS24613-272	MS24613-232 MS24613-302	MS24613-212 through MS24613-312
8	MS24614-212 and MS24614-272	MS24614-232 MS24614-302	MS24614-212 through MS24614-312
9	MS24655-211 and MS24655-271	MS24655-231	MS24655 -211 -271 -221 -281 -231 -311 -241
0	MS24656-211 and MS24656-271	MS24656-231	MS24656 -211 -271 -221 -281 -231 -311 -241
11	MS90310-211 and MS90310-271	MS90310-231	MS90310 -211 -271 -221 -281 -231 -311 -241
12	MS90311-211 and MS90311-271	MS90311-231	MS90311 -211 -271 -221 -281 -231 -311 -241

MIL-DTL-8834J
w/Amendment 1
APPENDIX A

TABLE A-I. Group submission for qualification tests and extent of approval - Continued

Group	Basic switches	Other switches	Extent of approval
13	MS14001-212 and MS14001-272	MS14001-232 MS14001-302	MS14001-212 through MS14001-312
14	MS14002-212 and MS14002-272	MS14002-232 MS14002-302	MS14002-212 through MS14002-312
15	MS14003-212 and MS14003-272	MS14003-232 MS14003-302	MS14003-212 through MS14003-312
16	MS21346-211 and MS21346-271	MS21346-231	MS21346 -211 -271 -221 -281 -231 -311 -241
17	MS21347-211 and MS21347-271	MS21347-231	MS21347 -211 -271 -221 -281 -231 -311 -241
18	MS21350-321	None	MS21350-321
19	MS21351-321 CANCELLED	None	MS21351-321 CANCELLED
20	MS21352-351 CANCELLED	MS21352-321 -331 -341	MS21352-321 CANCELLED -331 CANCELLED -341 CANCELLED -351 CANCELLED
21	MS21353-351	MS21353-321 -331 -341	MS21353-321 -331 -341 -351
22	MS21354-211 and MS21354-271	MS21354-231	MS21354 -211 -271 -221 -281 -231 -311 -241
23	MS21355-211 and MS21355-271	MS21355-231	MS21355 -211 -271 -221 -281 -231 -311 -241
24	MS21356-211 and MS21356-271	MS21356-231	MS21356 -211 -271 -221 -281 -231 -311 -241
25	MS21357-211 and MS21357-271	MS21357-231	MS21357 -211 -271 -221 -281 -231 -311 -241

MIL-DTL-8834J
w/Amendment 1
APPENDIX A

MOUNTING AND TERMINAL HARDWARE

A.30. Scope. Mounting and terminal hardware shall be of the following design and construction as specified (see 3.1).

A.40. Mounting hardware.

A.40.1 Nut, plain, hexagon, electrical thin.

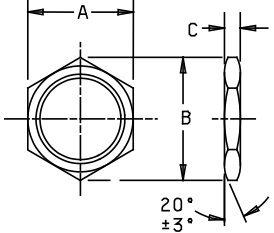
	Threads	A		B		C
		Min	Max	Min	Max	$\pm .005$ (0.13)
		.250-40 UNS-2B (.35)	.302 (7.67)	.313 (7.95)	.348 (8.84)	.361 (9.17)
.469-32 UNS-2B (11.91)	.553 (14.05)	.564 (14.33)	.630 (16.00)	.651 (16.54)	.078 (1.98)	
Material	ASTM B16, Alloy UNS C36000					
Finish	Brass nickel, shall enable the switch to meet performance requirements of this specification(Matte) Mil. hardware, can be replaced by MS 25082-B14 (.250-40) or MS25082-B8 (.469-32)					

A.40.2 Lockwasher, internal tooth

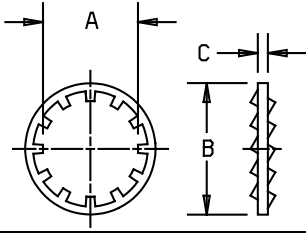
	Size	A		B		C
		Min	Max	Min	Max	$\pm .002$ (0.05)
		.250 (6.35)	.256 (6.50)	.267 (6.78)	.395 (10.03)	.410 (10.41)
.469 (11.91)	.472 (11.99)	.480 (12.19)	.593 (15.06)	.607 (15.42)	.018 (0.46)	
Material	Steel	Shall enable the switch to meet performance requirements of this specification.				
Finish	Steel	Suitably protected to resist corrosion Mil. hardware, CRES, Can be replaced by NASM35333-135 (.250 size) or NASM35333-136(.469 size)				

A.40.3 Locking ring.

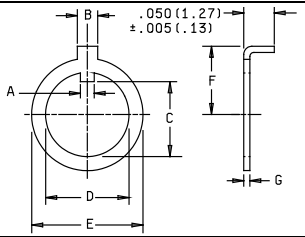
	Bush dia	A		B		C		D		E		F		G	
		Min	Max	Min	Max	Min	Max	Min	Max	Min	Max	Min	Max	Min	Max
	.469	.059 (1.50)	.065 (1.65)	.105 (2.67)	.115 (2.92)	.433 (11.00)	.440 (11.18)	.470 (11.94)	.480 (12.19)	.703 (17.86)	.735 (18.67)	.387 (n)	.397 (10.08)	.037 (0.94)	.043 (1.09)
Material	Steel	Shall enable the switch to meet performance requirements of this specification													
Finish	Steel	Suitably protected to resist corrosion. Mil hardware, CRES, can be replaced by MS25081-C4.													

A.50. Terminal hardware.

A.50.1 Terminal screw (Pan head).

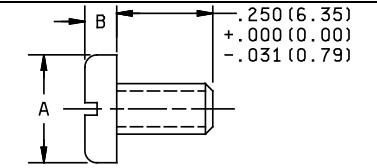
	Thread size	A		B	
		Min	Max	Min	Max
	.138-32 UNC-2A (3.51)	.256 (6.50)	.270 (6.86)	.072 (1.83)	.082 (2.08)
Material	Brass	ASTM B16, alloy UNS C36000			
Finish	Brass	Silver plate, tin plate, or nickel plate, shall enable the switch to meet performance requirements of this specification, (matte)			

MIL-DTL-8834J
APPENDIX A

A.50.2 Washer, lock-spring, helical series.

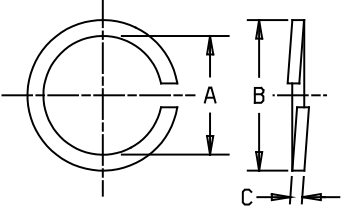
	Size	A		B	C	
		Min	Max	Max	Min	Max
	(No. 6) .138 (3.51)	.141 (3.58)	.151 (3.84)	.253 (6.43)	.031 (0.79)	.037 (0.94)
Material	Bronze	ASTM B139, alloy UNS C51000				
Finish	Bronze	Suitably protected to resist corrosion Mil. hardware, can be replaced by NASM35338-98.				

A.50.3 Screw with captive internal tooth lockwasher.

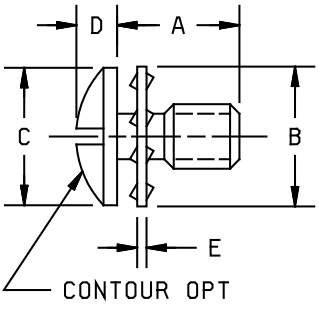
	Thread size	A	B	C	D	E
	.138-32 UNC-2A	.260 (6.60)	.295 (7.49)	.290 (7.37)	.087 (2.21)	.020 (0.51)
		.219 (5.56)	.265 (6.73)	.256 (6.50)	.071 (1.80)	.016 (0.41)
.164-32 UNC-2A	.250 (6.35)	.338 (8.58)	.322 (8.18)	.095 (2.41)	.022 (0.56)	
	.219 (5.56)	.327 (8.31)	.306 (7.77)	.085 (2.16)	.018 (0.46)	
Screw (Brass)	Material	ASTM B16, alloy UNS C36000, or C26000				
	Finish	Silver or tin plate				
	Mil. Hardware	None				
Lockwasher (Phos bronze)	Material	ASTM B139 alloy UNC alloy UNS 51000				
	Finish	Silver or tin plate				
	Mil. Hardware	None				

NOTES:

1. Dimensions are in inches.
2. Metric equivalents are in parenthesis.
3. Metric equivalents (to the nearest 0.01 mm) are given for general information only.
4. The terminal screw (pan head) shall be used in conjunction with the helical series lock-spring washer.
5. Captive washers shall rotate freely on the terminal screw.
6. The terminal screws with the captive internal tooth lockwasher shall be threaded to within .024 of the lockwasher.

MIL-DTL-8834J
w/Amendment 1

Custodians:

Army - CR
Navy - AS
Air Force - 85
DLA - CC

Preparing activity:

DLA - CC

(Project 5930-2011-035)

Review activities:

Army - AR, AT, MI
Navy - EC, MC
Air Force - 99

NOTE: The activities listed above were interested in this document as of the date of this document. Since organizations and responsibilities can change, you should verify the currency of the information above using the ASSIST Online database at <https://assist.dla.mil/>.