

INCH-POUND

MIL-DTL-8789F
w/AMENDMENT 2
14 July 2011
SUPERSEDING
MIL-DTL-8789F
w/AMENDMENT 1
5 July 2007

DETAIL SPECIFICATION

FITTING END, ATTACHABLE, HYDRAULIC, HIGH PRESSURE (3,000 PSI), GENERAL SPECIFICATION FOR

This specification is approved for use by all Departments and Agencies of the Department of Defense.

1. SCOPE

1.1 Scope. This specification covers the requirements for fitting end, attachable, hydraulic pressure (3000 psi).

1.2 Part or Identifying Number (PIN). The PIN consists of the letters MS (see 3.4), the basic specification number, and a dash for fitting size.

PIN:

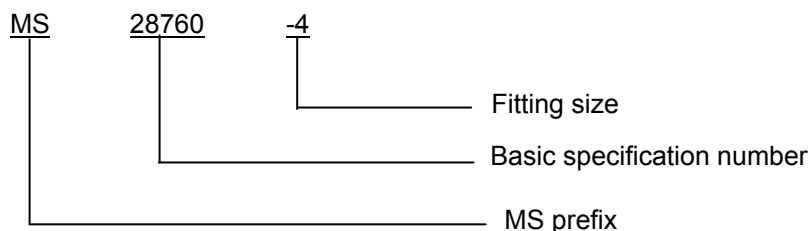

2. APPLICABLE DOCUMENTS

2.1 General. The documents listed in this section are specified in sections 3, 4, or 5 of this specification. This section does not include documents cited in other sections of this specification or recommended for additional information or as examples. While every effort has been made to ensure the completeness of this list, document users are cautioned that they must meet all specified requirements documents cited in sections 3, 4, or 5 of this specification, whether or not they are listed.

2.2 Government documents.

2.2.1 Specifications, standards, and handbooks. The following specifications, standards, and handbooks form a part of this document to the extent specified herein. Unless otherwise specified, the issues of these documents are those cited in the solicitation or contract.

Comments, suggestions, or questions on this document should be addressed to: DLA Land and Maritime, Columbus, Attn: VAI, P.O. Box 3990, Columbus, OH 43218-3990, or emailed to FluidFlow@dla.mil. Since contact information can change you may want to verify the currency of this address information using the ASSIST Online database at <https://assist.daps.dla.mil>.

MIL-DTL-8789F
w/AMENDMENT 2

DEPARTMENT OF DEFENSE SPECIFICATIONS

MIL-A-8625	-	Anodic Coatings for Aluminum and Aluminum Alloys
MIL-DTL-8788	-	Hose, Rubber, Hydraulic, High Pressure (3,000 psi)
MIL-DTL-8790	-	Hose Assemblies, Rubber, Hydraulic, High Pressure (3,000 psi)
MIL-PRF-5606	-	Hydraulic Fluid, Petroleum Base, Aircraft, Missile and ordnance Hydrocarbon Base, Aircraft and Missile
MIL-PRF-83282	-	Hydraulic Fluid, Fire Resistant, Synthetic Hydrocarbon Base, Metric, NATO Code Number H-537
MIL-PRF-87257	-	Hydraulic Fluid, Fire Resistant, Synthetic Hydrocarbon Base, Aircraft and Missile

DEPARTMENT OF DEFENSE STANDARDS

MIL-STD-889	-	Dissimilar Metals
MS28760	-	Fitting End, Straight, Attachable, Hydraulic and Pneumatic, High Pressure Hose (3,000 psi), Flared Tube
MS28761	-	Fitting End, Straight, Attachable, Hydraulic, High Pressure Hose (3,000 psi), Flareless Tube
MS28780	-	Fitting End, 45° Elbow, Attachable, Hydraulic, High Pressure Hose (3,000 psi), Flared Tube
MS28781	-	Fitting End, 90° Elbow, Attachable, Hydraulic, High Pressure Hose (3,000 psi), Flared Tube

(Copies of these documents are available online at <https://assist.daps.dla.mil/quicksearch/> or from the Standardization Document Order Desk, 700 Robbins Avenue, Building 4D, Philadelphia, PA 19111-5094.)

2.3 Non-Government publications. The following documents form a part of this document to the extent specified herein. Unless otherwise specified, issues of these documents are those cited in the solicitation or contract.

ASME INTERNATIONAL

ASME B46.1	-	Surface Texture (Surface Roughness, Waviness and Lay)
------------	---	---

(Copies of this document are available online at <http://www.asme.org> or from ASME International, Three Park Avenue, New York, NY 10016-5990.)

ASTM INTERNATIONAL

ASTM D380	-	Standard Test Methods for Rubber Hose
ASTM A513	-	Standard Specification for Electric-Resistance-Welded Carbon and Alloy Steel Mechanical Tubing

(Copies of this document are available online at <http://www.astm.org> or from ASTM International, P.O. Box C700, 100 Barr Harbor Drive, West Conshohocken, PA 19428-2959.)

AMERICAN WELDING SOCIETY INC. (AWS)

AWS C3.4	-	Specification for Torch Brazing
AWS D17.1	-	Specification for Fusion Welding for Aerospace

(Copies of this document are available online at <http://www.aws.org/> or from the American Welding Society Inc., 550 N.W. Le Jeune Road, Miami, FL 33126.)

MIL-DTL-8789F
w/AMENDMENT 2

NCSL INTERNATIONAL

NCSL Z540.3 - Requirements for the Calibration of Measuring and Test Equipment

(Copies of these documents are available online at <http://www.ncsli.org> or from NCSL International 2995 Wilderness Place, Suite 107 Boulder, Colorado 80301-5404.)

INTERNATIONAL ORGANIZATION FOR STANDARDIZATION (ISO)

ISO 17025 - General requirements for the competence of testing and calibration laboratories

(Copies of these documents are available online at <http://www.iso.ch> or from the International Organization for Standardization American National Standards Institute, 11 West 42nd Street, 13th Floor, New York, NY 10036.)

SAE INTERNATIONAL

SAE-AMS-H-6875 - Heat Treatment of Steel Raw Materials
 SAE-AMS-QQ-A-225/9 - Aluminum Alloy 7075, Bar, Rod, and Wire, and Special Shapes; Rolled, Drawn, or Cold Finished-UNS A97075
 SAE-AMS-QQ-A-367 - Aluminum Alloy Forgings
 SAE-AMS-QQ-P-416 - Plating, Cadmium (Electrodeposited)
 SAE-AMS-2658 - Hardness and Conductivity Inspection of Wrought Aluminum Alloy Parts
 SAE-AMS-2700 - Passivation of Corrosion Resistant Steels
 SAE-AMS-2772 - Heat Treatment of Aluminum Alloy Raw Materials
 SAE-AMS-4111 - Aluminum Alloy Forgings 7.7Zn-2.5Mg-1.5Cu-0.16Cr (7049-T73) Solution and Precipitation Heat Treated (UNS A97049) R
 SAE-AMS-4124 - Aluminum Alloy, Rolled or Cold Finished Bars, Rods, and Wire 5.6Zn - 2.5Mg - 1.6Cu - 0.23Cr (7075-T7351) Solution Heat Treated, Stress Relieved by Stretching, and Overaged-UNS A97075
 SAE-AMS-4141 - Aluminum Alloy Die Forgings 5.6Zn - 2.5Mg - 1.6Cu - 0.23Cr (7075-T73) Solution and Precipitation Heat Treated
 SAE-AMS-5050 - Steel Tubing, Seamless 0.15 Carbon, Maximum Annealed
 SAE-AMS-6322 - Steel Bars, Forgings and Rings 0.50Cr-0.55Ni-0.25Mo (0.38-0.43C) (SAE 8740)
 SAE-AMS-6325 - Steel, Bars and Forgings 0.50Cr-0.55Ni-0.25Mo (0.38-0.43C) (SAE 8740) Heat Treated, 105 psi (724MPa) Tensile Strength
 SAE-AMS-6327 - Steel Bars and Forgings 0.50Cr-0.55Ni-0.25Mo (0.38-0.43C) (SAE 8740) Heat Treated, 125,00 psi (862MPa) Tensile Strength
 SAE-AMS-6349 - Steel Bars 0.95Cr - 0.20Mo (0.38 - 0.43C) (SAE 4140) Normalized-UNS G41400
 SAE-AMS-6382 - Steel, Bars, Forgings, and Rings 0.95Cr - 0.20Mo (0.38 - 0.43C) (SAE 4140) Annealed-UNS G41400
 SAE-AMS6346 - Steel Bars 0.95Cr - 0.20Mo (0.28 to 0.33C) (SAE 4130) Hardened and Tempered, 125 Ksi (862 MPa) Tensile Strength
 SAE-AMS6370 - Steel, Bars, Forgings, and Rings 0.95Cr - 0.20Mo (0.28 - 0.33C) (SAE 4130)-UNS G41300
 SAE-ARP908 - Torque Requirements Installation and Qualification Test, Hose and Tube Fittings
 SAE-AS4395 - Fitting End-Flared Tube Connection, Design Standard
 SAE-AS603 - Impulse Testing of Hydraulic Hose, Tubing, and Fitting Assemblies
 SAE-AS8879 - Screw Threads - UNJ Profile, Inch

MIL-DTL-8789F
w/AMENDMENT 2

- | | | |
|-------------|---|--|
| SAE-AS33514 | - | Fitting End, Standard Dimensions for Flareless Tube Connection and Gasket Seal |
| SAE-J1966 | - | Lubricating Oils, Aircraft Piston Engine (Non-Dispersant Mineral Oil) |

(Available from SAE International, 400 Commonwealth Drive, Warrendale, PA 15096-0001, Tel: 877-606-7323 (inside USA and Canada) or 724-776-4970 of these documents (outside USA), www.sae.org.)

2.4 Order of precedence. In event of a conflict between the text of this document and the references cited herein (except for related specification sheets), the text of this document takes precedence. Nothing in this document, however, supersedes applicable laws and regulations unless a specific exemption has been obtained.

3. REQUIREMENTS

3.1 Specification sheets. The individual item requirements shall be as specified herein and in accordance with the applicable specification sheet. In the event of any conflict between the requirements of this specification and the specification sheet, the latter shall govern.

3.2 Qualification. The fittings furnished under this specification shall be products that are authorized by the qualifying activity for listing on the applicable qualified products list before contract award (see 4.5 and 6.3).

3.3 Materials. Materials used shall be as specified herein. However, materials not specified herein shall be of a quality that will enable the fitting end to meet the requirements specified herein.

3.3.1 Recycled, recovered, or environmentally preferable materials. Recycled, recovered, or environmentally preferable materials should be used to the maximum extent possible provided that the material meets the operational and maintenance requirements, and promotes economically advantageous life cycle costs.

3.3.2 Dissimilar metals. When dissimilar metals are used in intimate contact with each other, protection against electrolysis and corrosion shall be provided. Dissimilar metals such as brass, copper or steel (except corrosion-resisting steel passivated in accordance with SAE-AMS-2700, type 6 or 7) shall not be used in intimate contact with aluminum or aluminum alloy. Protective measures for dissimilar metals shall be in accordance with MIL-STD-889.

3.3.3 Electrical conductivity and hardness. Aluminum alloy fittings and nuts shall meet the electrical conductivity and hardness requirements of SAE-AMS-2658 or equivalent.

3.3.4 Heat treatment.

3.3.4.1 Aluminum Alloy. Aluminum alloy fittings and nuts shall be supplied in the final temper as specified in table I. When fitting material is purchased in other than the final temper, the heat treatment shall be in accordance with SAE-AMS-2772.

3.3.4.2 Steel. Corrosion-resistant steel fittings and nuts shall have a hardness of Rockwell B80 minimum. When required steel shall be heat treated in accordance with SAE-AMS-H-6875.

MIL-DTL-8789F
w/AMENDMENT 2TABLE I. Material.

Type of part	Material	Specification
Nipples, nuts, and elbows <u>1/</u>	Steel	SAE-AMS-6322
		SAE-AMS-6325
		SAE-AMS-6327
		SAE-AMS-6349 alloy 4140
		SAE-AMS6370 alloy 4130 <u>2/</u>
		SAE-AMS-6382 alloy 4140
Socket, bodies	Aluminum alloy	SAE-AMS-QQ-A-225/9 alloy 7075 - T73
		SAE-AMS-QQ-A-367 alloy 7075 - T7351
		SAE-AMS-4111 alloy 7049-T73
		SAE-AMS-4141 alloy 7075 - T73
		SAE-AMS-4124 alloy 7075 - T7351

1/ The elbow may be fabricated from an alternate material using steel tubing in accordance with SAE-AMS-5050 or ASTM A513 grade 1010.

2/ Nuts shall be 4130 in accordance with SAE-AMS6346 4 cold finished (drawn).

3.4 Design and construction. The design and construction of the attachable end fitting shall conform to MS28760, MS28761, MS28780, or MS28781 and this specification, as applicable. The end fitting shall be suitable for use with hose qualified to MIL-DTL-8788 to form flexible assemblies, which shall meet all the requirements of MIL-DTL-8790.

3.4.1 Fittings. Fitting ends shall be fabricated of materials listed in table I and as specified in the applicable specification sheets.

3.4.2 Finish.

Aluminum alloy: Anodic treatment in accordance with MIL-A-8625, type II, class 2.

Steel: Cadmium plate in accordance with SAE-AMS-QQ-P-416, type II, class 3, color optional.

3.4.3 Surface roughness. Surface roughness of machined parts shall not exceed 125 μ inches (3.18 μ m) arithmetical average, except for the sealing of fittings which shall not have annular tool marks in excess of 100 micro inches (2.54 μ m) arithmetical average. The arithmetical average values shall be interpreted in accordance with ASME B46.1.

3.4.4 Dimensions. Dimensions and tolerances shall be as shown on the applicable specification sheet. Dimensional requirements are applicable after heat treatment and protective finish.

MIL-DTL-8789F
w/AMENDMENT 2

3.4.5 Threads. All threads shall be in accordance with SAE-AS8879, except root radius is not required on incomplete threads. External threads on aluminum alloy shall be produced by machining, single point method or grinding.

3.5 Examination of product. The fitting shall conform to the material (see 3.3), design and construction (see 3.4), identification markings (see 3.9) and workmanship (see 3.10) specified herein and in the applicable specification sheets, when examined as specified in 4.9.1.

3.6 Performance. The fittings shall meet the following performance requirements. When hose assemblies are required for testing the fittings shall be assembled on qualified hose in accordance with MIL-DTL-8788.

3.6.1 Bulge resistance (connector to hose assembly). The ball gage, used to determine the inner tube diameter at the bulge, shall fall through the section under its own weight through the section of the end-fitting insert in the hose, when tested in 4.9.2.

3.6.2 Proof pressure. The hose assembly shall not leak or fail during or at the completion of the test, as specified in 4.9.3, with the applicable proof pressure specified in table II. There shall be no visual evidence of damage or permanent deformation.

TABLE II. Performance characteristics. 1/ 2/

Hose dash size	Proof pressure, min psi (bar)	Burst pressure, min psi (bar)	Operating pressure psi (bar)	Bend radius inside, min inches (mm)	Assembly length of test samples inches (cm) 3/
4	8,000 (207)	16,000 (1103)	3,000 (207)	3.00 (76.20)	16 (41)
5	7,000 (483)	14,000 (965)	3,000 (207)	3.38 (85.85)	18 (46)
6	7,000 (483)	14,000 (965)	3,000 (207)	5.00 (127.00)	21 (53)
8	7,000 (483)	14,000 (965)	3,000 (207)	5.75 (146.05)	24 (61)
10	6,000 (414)	12,000 (827)	3,000 (207)	6.50 (165.10)	30 (76)
12	6,000 (414)	12,000 (827)	3,000 (207)	7.75 (196.85)	33 (84)
16	5,000 (345)	10,000 (689)	3,000 (207)	9.63 (244.60)	24 (61)

1/ Dimensions are in inches.

2/ Metric equivalents are given for information only.

3/ Represents length of assembly in accordance with MIL-DTL-8790. A minimum free length of 12 inches (30.5 cm) shall remain between fittings.

3.6.3 Leakage. The hose assembly shall not show any evidence of leakage during or at the completion of the test, when tested in 4.9.4.

3.6.4 Burst pressure. There shall be no leakage at the end fittings or in the hose below and including the minimum burst pressure specified in table II when tested in 4.9.5. The fittings shall not loosen or disconnect from the hose. The hose shall not burst or develop a permanent blister.

MIL-DTL-8789F
w/AMENDMENT 2

3.6.5 Impulse. The hose assembly shall not show any evidence of leakage, burst, or fitting loosening or blow-off, when tested in [4.9.6](#).

3.6.6 Low temperature flexibility. The hose assembly shall not leak or fail during or at the completion of the test, when tested in [4.9.7](#). There shall be no visual evidence of damage or permanent deformation.

3.6.7 Over-tightening torque. The fitting assembly shall not show any evidence of material failure, deformation of the assembly or difficulty in turning the swivel nut on the nipple by hand, when tested in [4.9.8](#).

3.7 Brazing. Unless otherwise specified, fittings requiring brazing shall be copper hydrogen brazed in accordance with AWS C3.4.

3.8 Welding. Fittings requiring welding shall be welded in accordance with AWS D17.1.

3.9 Identification of product. Each end fitting assembly shall be identified with a durable permanently attached tag. This tag shall show the PIN, Commercial and Government Entity (CAGE) code, and manufacturer's name or trademark.

3.10 Workmanship. All parts of the end fitting shall be uniform in quality and free from irregularities, defects, or foreign matter.

4. VERIFICATION

4.1 Classification of inspection. The inspection requirements specified herein are classified as follows:

- a. Qualification inspection (see [4.5](#)).
- b. Conformance inspection (see [4.6](#)).

4.2 Inspection conditions. Unless otherwise specified, all required inspections shall be performed in accordance with the test conditions specified in [4.8](#).

4.3 Test equipment and inspection facilities. Test and measuring equipment and inspection facilities of sufficient accuracy, quality, and quantity to permit performance of the required inspection shall be established and maintained by the contractor. The establishment and maintenance of a calibration system to control the accuracy of the measuring and test equipment shall be in accordance with ISO 17025 and NCSL Z540.3 as applicable.

4.4 Responsibility for compliance. All items shall meet all requirements of sections [3](#), [4](#), and [5](#). The inspection set forth in this specification shall become a part of the contractor's overall inspection system or quality program. The absence of any inspection requirements in the specification shall not relieve the contractor of the responsibility of ensuring that all products or supplies submitted to the Government for acceptance comply with all requirements of the contract. Sampling inspection, as part of manufacturing operations, is an acceptable practice to ascertain conformance to requirements, however, this does not authorize submission of known defective material, either indicated or actual, nor does it commit the Government to accept defective material.

4.5 Qualification inspection. Qualification inspection shall be performed at a laboratory acceptable to the qualifying activity on sample units produced with equipment and procedures used in production.

MIL-DTL-8789F
w/AMENDMENT 2

4.5.1 Samples for qualification. Qualification samples shall be representative of the products proposed to be furnished to this specification. Samples shall consist of sufficient end fittings to permit the fabrication of 10 hose assemblies of each size and of the lengths specified in [table II](#). The samples shall be hose in accordance with MIL-DTL-8788 and assembled with end fittings of the same size. Fittings shall be qualified with hose from a minimum of two specific current qualified hose manufacturer(s).

4.5.2 Qualification inspection routine. Samples shall be subjected to qualification testing as specified in [table III](#) in the sequence specified in [table IV](#).

TABLE III. Qualification inspection.

Requirement	Requirement paragraph	Test method paragraph
Examination of product	3.5	4.9.1
Bulge resistance	3.6.1	4.9.2
Proof pressure	3.6.2	4.9.3
Leakage	3.6.3	4.9.4
Burst resistance	3.6.4	4.9.5
Impulse	3.6.5	4.9.6
Low temperature flexibility	3.6.6	4.9.7
Over-tightening torque	3.6.7	4.9.8

TABLE IV. Qualification inspection sequence.

Required qualification test	Test method paragraph	Sample number										
		1	2	3	4	5	6	7	8	9	10	
Examination of product	4.9.1	X	X	X	X	X	X	X	X	X	X	X
Bulge resistance	4.9.2	X	X	X	X							
Proof pressure	4.9.3	X	X	X	X	X	X	X	X	X	X	X
Leakage	4.9.4					X	X					
Burst resistance	4.9.5					X	X					
Impulse	4.9.6	X	X	X	X							
Low temperature flexibility	4.9.7							X	X			
Over-tightening torque	4.9.8									X	X	
Proof pressure	4.9.3							X	X			

4.5.3 Alternate qualification inspection criteria. Fittings shall meet the requirements of 4.5.2. Alternatively, when the identical hose is manufactured and tested in accordance with MIL-DTL-8788, and the identical hose assemblies are manufactured and tested in accordance with MIL-DTL-8790, using identical fittings in accordance with MIL-DTL-8789, it is not necessary to test the fittings to meet the qualification requirements of this specification. This applies when substantially identical test requirements and test procedures are required for the assembly and the individual components and upon documented approval by the qualifying activity.

4.5.4 Failures. One or more failures shall be cause for refusal to grant qualification approval.

4.6 Conformance inspection.

MIL-DTL-8789F
w/AMENDMENT 2

4.6.1 Sampling tests (inspection of product delivery). Sampling tests shall consist of the examinations specified in table V. The inspection sample shall be selected at random from the production lot without regard to quality and shall be the size specified in table VI.

4.6.1.1 Nonconformance of sampling tests. If one or more defects are identified, then the entire production lot shall be screened for that defect and all defects shall be removed. A second inspection sample shall then be selected and the sampling tests shall be performed again. If one or more defects are identified from the second inspection lot, then the entire production lot shall be rejected and not supplied to this specification.

4.6.2 P1 inspection tests. Fittings shall be randomly selected from a production lot to form an inspection sample and shall be subjected to sampling and P1 inspection tests specified in [table V](#).

4.6.2.1 P1 inspection samples. Sampling and P1 inspections as specified in table V shall be performed on 3 assemblies (6 fittings) for each size at least once per year regardless of the total number of fittings produced. At least 3 of the 6 fittings, used for testing, shall be flared fittings with the greatest bend angle. If no flared fittings were produced, flareless fittings shall be used. The 6 fittings selected shall be as representative as possible of those produced during the period in terms of fitting material and joint configuration. If there has been no production for a particular size, during the past year, P1 inspections are not required for that size.

4.6.2.2 P1 inspections performed at bulk hose or assembly level. Required P1 inspections tests at the fitting level that were already performed at the bulk hose or assembly level may be eliminated if documented approval has been obtained from the qualifying activity.

TABLE V. Sampling and P1 inspections.

Requirement	Requirement paragraph	Test method	Sampling	P1 1/
Examination of product	3.5	4.9.1	X	
Proof pressure	3.6.2	4.9.3		X
Leakage	3.6.3	4.9.4		X
Burst pressure	3.6.4	4.9.5		X

1/ These are destructive tests, also see [4.6.3.3](#).

TABLE VI. Inspection sample.

Production lot size	Sample size
1 to 8	all
9 to 90	8
91 to 150	12
151 to 280	19
281 to 500	21
501 to 1,200	27
1201 to 3,200	35
3201 to 10,000	38
10,001 to 35,000	46

MIL-DTL-8789F
w/AMENDMENT 2

4.6.2.3 Nonconformance of P1 inspections. If a sample fails any P1 inspection test, acceptance and shipment of the product shall be discontinued until corrective action acceptable to the qualifying activity has been taken. After the corrective action has been taken, sampling or P1 inspection, see table V, shall be repeated on additional samples. At the discretion of the qualifying activity this may include all sampling or P1 inspections, or the inspection which the original sample failed. However final acceptance of the hose or hose assemblies shall be withheld until the P1 inspection has shown that the corrective action was successful.

4.6.2.4 Disposition of P1 test specimens. Test specimens which have been subjected to P1 testing are considered damaged and shall not be delivered on a contract or purchase order.

4.6.3 P2 inspections. P2 inspections as specified in table VII, shall be performed on 2 fittings at least once per year regardless of the total number of fittings produced. The fittings shall be of any bend angle and joint configuration. The 2 fittings selected shall be as representative as possible of those produced during the period, in terms of material used for the threaded parts. The size of the 2 fittings shall be determined based on the fitting size that is most likely to fail if there was a defect. If there has been no production during the past year, P2 inspections are not required.

TABLE VII. P2 inspections. 1/

Requirement	Requirement paragraph	Test method
Over-tightening torque	3.6.7	4.9.8

1/ If no failures have occurred after two consecutive 12 month intervals then P2 testing can be done every 36 months.

4.6.3.1 Disposition of test specimens. Test specimens, which have been subjected to P2 inspection testing, are considered damaged and shall not be delivered on a contract or purchase order.

4.6.3.2 Nonconformance of P2. If a sample fails the P2 inspection test acceptance, shipment of the product shall be discontinued until corrective action acceptable to the qualifying activity has been taken. After the corrective action has been taken P2 inspection, see table VII, shall be repeated on additional samples. At the discretion of the qualifying activity this may include all inspections, or the inspection which the original sample failed. Sampling and P1 inspections may be reinstated. However final acceptance of the hose or hose assemblies shall be withheld until the P2 inspection has shown that the corrective action was successful.

4.6.3.3 Alternate conformance inspection criteria. When the identical hose is manufactured and tested in accordance with MIL-DTL-8788, and the identical hose assemblies manufactured and tested in accordance with MIL-DTL-8790, using identical fittings in accordance with MIL-DTL-8789, it is not necessary to test the fittings to meet the conformance inspection data requirements of this specification. This applies when substantially identical test requirements and test procedures are required for the assembly and the individual components and upon documented approval by the qualifying activity.

MIL-DTL-8789F
w/AMENDMENT 2

4.7 Additional QPL test and reporting requirements.

4.7.1 Retention of qualification. To retain qualification, the contractor shall submit a test report to the qualifying activity at 12 month intervals. The qualifying activity shall establish the initial reporting date. Each report shall consist of a summary of test and inspection results required by this specification that were performed during the 12 month reporting interval. As a minimum, the report shall include the following:

- a. Number of lots produced and tested, including lot and sample sizes for each lot.
- b. Identify which tests were performed.
- c. Quantities passed.
- d. Quantities failed.
- e. All reworked sampling lots shall be accounted for and identified. A summary of corrective action taken shall be included.

4.7.2 Loss of product qualification.

4.7.2.1 Failure to meet test requirements. The manufacturer shall immediately notify the qualifying activity at any time during the 12-month reporting period when the qualified product fails to meet the test and inspection requirements of this specification. The manufacturer shall identify and indicate what corrective action will be taken to correct the problem. Failure to take corrective action acceptable to the qualifying activity may result in removal of the product from the QPL.

4.7.2.2 Failure to submit summary test data report. Failure to submit a report within 30 days after the end of the 12 month reporting period may result in loss of qualification for the product.

4.7.2.3 Change to manufacturing process, materials or equipment. The manufacturer shall notify the qualifying activity, in writing, of any changes in the manufacturing process, materials, or equipment used to manufacture a QPL product. Subsequently, the qualifying activity will notify the manufacturer, in writing, if a full re-qualification, partial re-qualification, or no additional testing is required as a result of these changes.

4.7.2.4 No production during reporting period (12 months). When no production occurs during the reporting period, a report shall be submitted to the qualifying activity certifying that the manufacturer still has the capability and facilities necessary to produce the QPL product.

4.8 Test conditions.

4.8.1 Preparation of specimens. Test samples shall be assembled with samples of hose of applicable size in accordance with MIL-DTL-8788. Assembly lengths shall be as shown in [table II](#).

4.8.2 Test fluids. Unless otherwise specified, the test fluid shall be lubricating oil grade 50 in accordance with SAE-J1966 or hydraulic fluid in accordance with MIL-PRF-5606, MIL-PRF-83282, MIL-PRF-87257 or water.

4.8.3 Aging of samples. When specified, specimens shall be either air aged (see 4.8.3.1) or oil aged (see 4.8.3.2) prior to testing.

4.8.3.1 Air aging. Air aged samples shall be kept in air at a temperature of 158°F ±2°F (65.6°C ±1.11°C) for a minimum of 168 continuous hours.

MIL-DTL-8789F
w/AMENDMENT 2

4.8.3.2 Oil aging. Samples shall be completely immersed in hydraulic fluid in accordance with MIL-PRF-5606, MIL-PRF-83282 or MIL-PRF-87257 at a temperature of 158°F ±2°F (65.6°C ±1.11°C) for a minimum of 168 continuous hours. Air shall not be trapped in the bore of the tube during this aging period. The volume of fluid used shall be sufficient to completely fill and cover the samples. Both the samples and the fluid shall be placed in a non-pressurized closed type container or in a reflux type condenser to prevent distillation of the volatile matter in the fluid. For qualification tests, a new batch of oil shall be used for each group of test samples. For quality conformance tests, a new batch of oil shall be used for each 10 or fewer tests.

4.9 Test methods.

4.9.1 Examination of product. The end fitting shall be visually examined for material (see 3.3), design and construction (see 3.4), identification markings (see 3.9), and workmanship (see 3.10).

4.9.2 Bulge resistance test. Hose assemblies when subjected to the bulge resistance test shall meet the requirements of 3.6.1. The following details shall apply:

- a. Four hose assembly samples that have been prepared for the impulse test (see 4.9.6) shall be checked for bulging of the inner tube and reduction of fitting nipple inner diameter caused by the attachment of end fittings. Measurements shall be taken on assemblies using a ball-end type gage.
- b. The diameter of the ball shall not be less than .002 inch (0.05 mm) but no greater than .001 inch (0.03 mm) smaller than the bulge diameter "A" specified in table VIII.
- c. The weight of the ball, in ounces, shall be no more than the hose size tested.
- d. Without using force or lubrication, the ball shall be placed inside the end of the assembly at the bulge gage inspection point shown on figure 1.

TABLE VIII. Hose inner tube diameter at the bulge.

Hose dash size	A diameter ^{1/} min inches (mm)
4	.146 (3.71)
5	.177 (4.50)
6	.271 (6.88)
8	.365 (9.27)
10	.455 (11.56)
12	.568 (14.43)
16	.778 (19.76)

^{1/} Diameter A, indicates both the minimum permissible inner tube diameter at the bulge, and the minimum nipple ID of the fitting, when the fitting is assembled with the hose.

MIL-DTL-8789F
w/AMENDMENT 2

FIGURE 1. Minimum diameter of hose inner tube at the bulge.

4.9.3 Proof pressure test. Each hose assembly shall be tested in accordance with ASTM D380 and subjected to the applicable proof pressure listed in [table II](#). Each hose assembly shall meet the requirements of [3.6.2](#). The test fluid shall be water or fluid in accordance with MIL-PRF-5606, MIL-PRF-83282 or MIL-PRF-87257.

4.9.4 Leakage test. Two unaged hose assemblies shall be tested as specified in ASTM D380 and meet the requirements of [3.6.3](#). The following details shall apply:

- a. The samples shall be a minimum of 12 inches (30.5 cm) in length.
- b. Test fluid shall be water or hydraulic fluid in accordance with MIL-PRF-5606, MIL-PRF-83282 or MIL-PRF-87257.
- c. Samples shall be subjected to 70% of the minimum burst pressure as specified in [table II](#) and held for 5 minutes.
- d. After 5 minutes, the pressure shall be released and reduced to zero. Then the pressure shall be raised again to 70% of the minimum burst pressure and held for another 5 minutes.
- e. The adjacent outer cover shall be carefully inspected during this period for any wicking or leakage of the test fluid.
- f. After completion of the leakage test on these samples, they shall be subjected to the burst resistance test specified in [4.9.5](#).

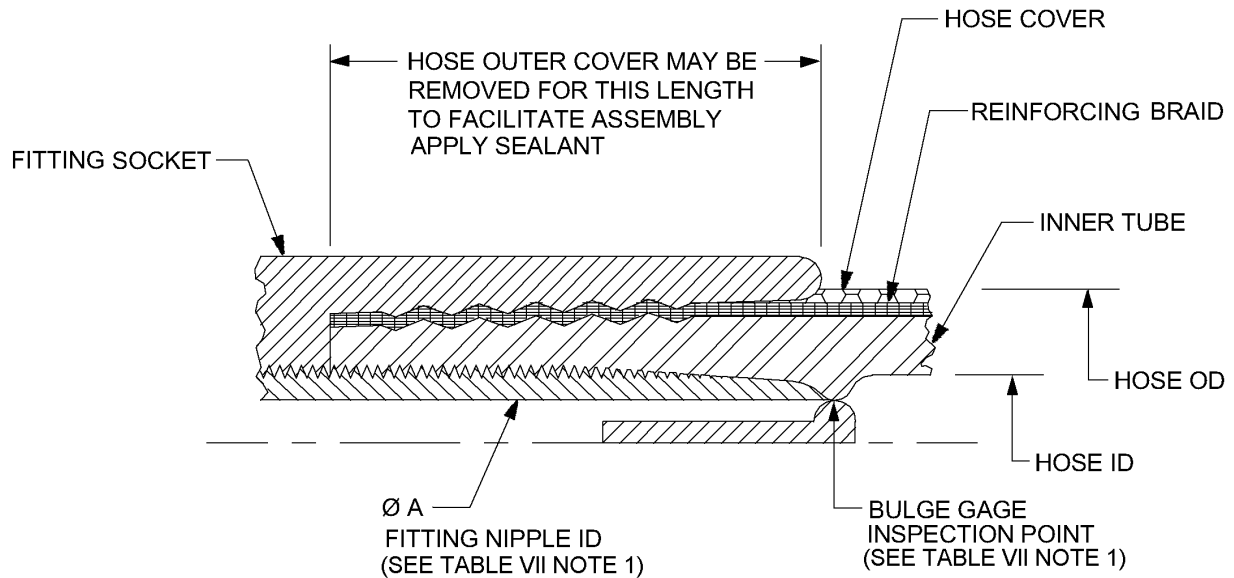
MIL-DTL-8789F
w/AMENDMENT 2

4.9.5 Burst pressure test. Two unaged hose assemblies shall be subjected to the burst pressure specified in [table II](#) and shall meet the requirements of [3.6.4](#). The following details shall apply:

- a. The assemblies shall be a minimum of 12 inches (30.5 cm) in length.
- b. During this test, the hose assembly shall be fastened at one end to the source of pressure, the hose shall be extended straight, and the free end shall not be restrained or fastened in any way.
- c. Test fluid shall be water or hydraulic fluid in accordance with MIL-PRF-5606, MIL-PRF-83282 or MIL-PRF-87257.
- d. The rate of pressure rise shall be 25,000 +0/-10,000 psi per minute (1723.7 bar +0/-689.5 bar per minute).
- e. Pressure shall be applied until failure occurs.
- f. The actual pressure at which the samples burst or otherwise fail shall be recorded and record the site of the burst.

4.9.6 Impulse test. Four hose assemblies when subjected to impulse testing in accordance with SAE-AS603 shall meet the requirements of [3.6.5](#). The following details shall apply:

- a. Four samples of the length specified in shall be subjected to the proof pressure test (see [4.9.3](#)), prior to impulsing.
- b. Two of the four samples shall be air aged and the other two shall be oil aged.
- c. Operating pressure for impulse testing shall be specified in [table II](#) and impulse cycles shall be specified in [table IX](#).
- d. Only hose size 16 shall be tested without surge peaks and in a straight position with one end free.
- e. Test fluid shall conform to MIL-PRF-5606, MIL-PRF-83282 or MIL-PRF-87257, except that up to 25% of the total volume may be fluid in accordance with SAE-J1966, grade 50.
- f. The fluid temperature, measured in the manifold, shall be held at 120°F ± 20° F(48.9°C ±11.1°C).

TABLE IX. Impulse cycles.

Hose dash size	Minimum impulse cycles per hose	Minimum average impulse cycles <u>1/</u>	Maximum impulse cycles that can be used to compute average <u>2/</u>
4	100,000	---	---
5	100,000	---	---
6	100,000	---	---
8	75,000	100,000	150,000
10	50,000	75,000	100,000
12	35,000	50,000	70,000
16	45,000	55,000	75,000

1/ The average of the test samples shall not be below the values listed in this column.

2/ When test samples impulse cycles are averaged, the maximum cycles that may be used to compute the average shall not exceed the figures given in this column. This column is giving a limit to the number of impulse cycles that are allowed to calculate the average. While testing is in progress the test operator will take a reading of the impulse cycles completed. If it's higher than the value in column 4, the test operator would use the value specified in the table not the higher (true) value from the reading.

MIL-DTL-8789F
w/AMENDMENT 2

4.9.7 Low temperature flexibility test. Hose assemblies when subjected to low temperature flexibility testing shall meet the requirements of 3.6.6. The following details shall apply:

- a. Two samples of the lengths specified in table II.
- b. Both hose assemblies shall be assembled with fittings as specified herein.
- c. One sample shall be unaged, while the other shall be oil aged prior to testing.
- d. Samples shall be filled with fluid in accordance with MIL-PRF-5606, MIL-PRF-83282, or MIL-PRF-87257 and then exposed for 24 hours in a chamber at a temperature of $-65 \pm 2^{\circ}\text{F}$ ($-53.9^{\circ}\text{C} \pm 1.11^{\circ}\text{C}$).
- e. Size 16 hose may be exposed to a temperature of $-40^{\circ} \pm 2^{\circ}\text{F}$ ($-40^{\circ}\text{C} \pm 1.11^{\circ}\text{C}$).
- f. After the 24 hour exposure and while still at the specified temperature, the samples shall be flexed through 180° at each extreme travel (see figure 2), considered as one cycle, to the applicable inside bend radius specified in table II.
- g. Each sample shall be subjected to one cycle only, the duration of which shall be no greater than four seconds.
- h. After the flexing cycle (see figure 2), samples shall be removed from the cold chamber and subjected to the proof pressure test (see 4.9.3).

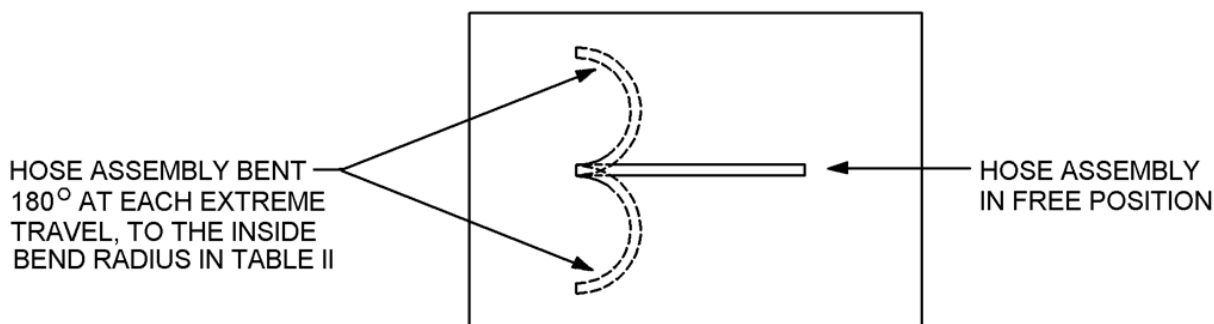

FIGURE 2. Flexibility test set up.

4.9.8 Over-tightening torque test. Flared and flareless type fitting when subjected to over-tightening torque in accordance with SAE-ARP908 shall meet the requirements of 3.6.7. The flared and flareless type fittings shall be installed on mating adapter ends (SAE-AS4395 or SAE-AS33514).

5. PACKAGING

5.1 Packaging. For acquisition purposes, the packaging requirements shall be as specified in the contract or order (see 6.2). When packaging of material is to be performed by DoD or in-house contractor personnel, these personnel need to contact the responsible packaging activity to ascertain packaging requirements. Packaging requirements are maintained by the Inventory Control Point's packaging activity within the Military Service or Defense Agency, or within the Military Service's System Commands. Packaging data retrieval is available from the managing Military Department's or Defense Agency's automated packaging files, CD-ROM products, or by contacting the responsible packaging activity.

6. NOTES

(This section contains information of a general or explanatory nature that may be helpful, but is not mandatory.)

MIL-DTL-8789F
w/AMENDMENT 2

6.1 Intended use. These end fittings covered by this specification are intended to be used with hydraulic pressure operating at 3000 psi.

6.1.1 Military unique rationale. The fittings covered by this specification are military unique fittings that mate with hose, in accordance with MIL-DTL-8788, to form hose assemblies, in accordance with MIL-DTL-8790. The military unique hose assemblies are intended to be used in high pressure hydraulic systems requiring interoperability and compatibility with associated components and equipment. The hose assemblies are required to withstand an operating pressure of 3,000 psi (206.8 bar). The interoperability and compatibility has been assured through strict adherence to the military detail specification requirements. Manufacturers of these items and users place great reliance on the detailed technical requirements to ensure the products meet the interoperability and compatibility requirements while encountering rapid ambient temperature fluctuations.

6.2 Acquisition requirements. Acquisition documents should specify the following:

- a. Title, number, and date of this specification.
- b. Title, number, and date of the applicable specification sheet and the complete PIN (see 1.2).
- c. Level of preservation, packaging, and marking required (see 5.1).

6.3 Qualification. With respect to products requiring qualification, awards will be made only for products which are, at the time of award of contract, qualified for inclusion in Qualified Products List QPL No.8789 whether or not such products have actually been so listed by that date. The attention of the contractors is called to these requirements, and manufacturers are urged to arrange to have the products that they propose to offer to the Federal Government tested for qualification in order that they may be eligible to be awarded contracts or orders for the products covered by this specification. Information pertaining to qualification of products may be obtained from DLA Land and Maritime, P.O. Box 3990, ATTN: DSCC-VQ, Columbus, Ohio 43218-3990 or emailed to vqp.chief@dla.mil. An online listing of products qualified to this specification may be found in the Qualified Products Database (QPD) at <https://assist.daps.dla.mil>.

6.3.1 Provisions governing qualification (SD-6). Copies of "Provisions Governing Qualification" are available online at <https://assist.daps.dla.mil> or from the Standardization Document Order Desk, 700 Robbins Avenue, Building 4D, Philadelphia, PA 19111-5094.

6.4 Environmentally preferable material. Environmentally preferable materials should be used to the maximum extent possible to meet the requirements of this specification. As of the dating of this document, the U.S. Environmental Protection Agency (EPA) is focusing efforts on reducing 31 priority chemicals. The list of chemicals and additional information is available on their website <http://www.epa.gov/epawaste/hazard/wastemin/index.htm>. Included in the EPA list of 31 priority chemicals are cadmium, lead, and mercury. Use of the materials on the list should be minimized or eliminated unless needed to meet the requirements specified herein (see section 3).

MIL-DTL-8789F
w/AMENDMENT 2

6.5 Subject term (key word) listing.

Adapter
Aircraft systems
Aluminum
Braze assembly
Cadmium
Flared
Flareless
Fuel
Hose
Oil
Pneumatic
Steel
Straight
Rubber
45°
90°

6.6 Amendment notations. The margins of this specification are marked with vertical lines to indicate modifications generated by this amendment. This was done as a convenience only and the Government assumes no liability whatsoever for any inaccuracies in these notations. Bidders and contractors are cautioned to evaluate the requirements of this document based on the entire content irrespective of the marginal notations.

CONCLUDING MATERIAL

Custodians:

Army - AV
Navy - AS
Air Force - 99
DLA - CC

Preparing activity:
DLA-CC

(Project 4730-2010-021)

Review activities:

Army - AT, MI
Navy - CG, MC, SA, SH
Air Force - 71

NOTE: The activities listed above were interested in this document as of the date of this document. Since organizations and responsibilities can change, you should verify the currency of the information above using the ASSIST Online data at <https://assist.daps.dla.mil>.