

INCH-POUND

MIL-DTL-8794F
w/AMENDMENT 5
1 September 2020
SUPERSEDING
MIL-DTL-8794F
w/AMENDMENT 4
9 May 2017

DETAIL SPECIFICATION

HOSE, SYNTHETIC RUBBER - HYDRAULIC FLUID, FUEL,
COOLANT, AND OIL RESISTANT, GENERAL SPECIFICATION FOR

This specification is approved for use by all Departments and Agencies of the Department of Defense.

1. SCOPE

1.1 Scope. This specification covers hose, synthetic rubber - hydraulic fluid, fuel, coolant, and oil resistant.

1.2 Part or Identifying Number (PIN). The hose PIN consists of the letter M, the basic specification number, hose size in dash number, applicable code, hose length, a dash, and hose length tolerance in 1/8th fraction of an inch or the letter B or S for bulk hose.

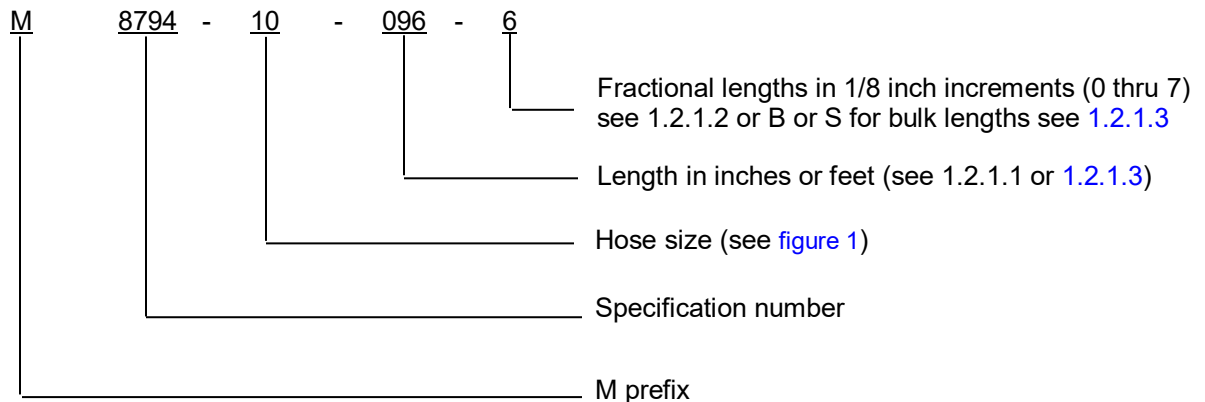

PIN examples:

M8794-8-014-5 (size 8 hose 14 5/8 inches long)
M8794-6-050-B (size 6 hose 50 feet bulk sizes)
M8794-4-025-S (size 4 hose 25 feet specific length)

1.2.1 Hose lengths.

1.2.1.1 Lengths of hose. Lengths of hose are represented by inches unless bulk hose is required (see 1.2.1.3).

Comments, suggestions, or questions on this document should be addressed to: DLA Land and Maritime, Attn: VAI, P.O. Box 3990, Columbus, OH 43218-3990, or emailed to FluidFlow@dla.mil. Since contact information can change you may want to verify the currency of this address information using the ASSIST Online database at <https://assist.dla.mil>.

AMSC N/A

FSC 4720



MIL-DTL-8794F
w/AMENDMENT 5

1.2.1.2 Fractions. Fractions are expressed in 1/8 inch increments (0 thru 7). Not applicable to bulk or specific hose lengths.

1.2.1.3 Bulk hose lengths. Bulk hose lengths are represented by the letter B or S. Bulk lengths are in increments of 20 feet or more (see 3.4.3.1). The S designator is used to define specific lengths in feet (see 3.4.3.2).

NOTE: For the inch designator insert the number zero in front of designator for lengths less than 100 inches.

Examples:

When 12 7/8 inch length is required the designator is: 012-7

When 96 inches is required the designator is: 096-0

When 30 feet total length is required the designator is: 030-B

When 30 feet continuous length is required with a 1% tolerance the designator is: 030-S

2. APPLICABLE DOCUMENTS

2.1 General. The documents listed in this section are specified in sections 3 and 4 of this specification. This section does not include documents cited in other sections of this specification or recommended for additional information or as examples. While every effort has been made to ensure the completeness of this list, document users are cautioned that they must meet all specified requirements of documents cited in sections 3 and 4 of this specification, whether or not they are listed.

2.2 Government documents.

2.2.1 Specifications standards, and handbooks. The following specifications, standards, and handbooks form a part of this document to the extent specified herein. Unless otherwise specified, the issues of these documents are those cited in the solicitation or contract.

FEDERAL STANDARDS

FED-STD-601 - Rubber: Sampling and Testing

COMMERCIAL ITEM DESCRIPTIONS

A-A-52624 - Antifreeze, Multi Engine Type

DEPARTMENT OF DEFENSE SPECIFICATIONS

MIL-DTL-5070 - Adapter, Hose to Tube, Pipe, and Flange, Reusable - Hydraulic, Fuel, and Oil Lines, General Specification for

MIL-DTL-5624 - Turbine Fuel, Aviation, Grades JP-4 and JP-5

MIL-DTL-8795 - Hose Assemblies, Elastomeric - Hydraulic Fluid, Fuel, and Oil Resistant, General Specification for

MIL-DTL-25524 - Turbine Fuel, Aviation, Thermally Stable (JPTS)

MIL-PRF-5606 - Hydraulic Fluid, Petroleum Base; Aircraft, Missile, and Ordnance

MIL-DTL-83133 - Turbine Fuel, Aviation, Kerosene Type, JP-8 (NATO F-34), NATO F-35, and JP-8+100 (NATO F-37)

MIL-DTL-8794F
w/AMENDMENT 5

- MIL-PRF-2104 - Lubricating Oil, Internal Combustion Engine, Combat/Tactical Service
- MIL-PRF-83282 - Hydraulic Fluid, Fire Resistant, Synthetic Hydrocarbon Base, Aircraft, Metric, NATO Code Number H-537
- MIL-PRF-87257 - Hydraulic Fluid, Fire Resistant; Low Temperature, Synthetic Hydrocarbon Base, Aircraft and Missile

DEPARTMENT OF DEFENSE STANDARDS

- MS28741 - Hose Assembly, Detachable End Fitting, Medium Pressure

(Copies of these documents are available online at <https://quicksearch.dla.mil/>.)

2.3 Non-Government publications. The following documents form a part of this document to the extent specified herein. Unless otherwise specified, the issues of these documents are those cited in the solicitation or contract.

ASTM INTERNATIONAL

- ASTM D380 - Standard Test Methods for Rubber Hose
- ASTM D412 - Standard Test Methods for Vulcanized Rubber and Thermoplastic Elastomers-Tension
- ASTM D413 - Standard Test Methods for Rubber Property-Adhesion to Flexible Substrate

(Copies of these documents are available online at <http://www.astm.org/>.)

EURO-ASIAN COUNCIL OF STANDARDIZATION, METROLOGY, AND CERTIFICATION (EASC)

- GOST 10227 - Jet Fuels Specifications

(Copies of this document are available from <https://www.ihs.com/>.)

INTERNATIONAL ORGANIZATION FOR STANDARDIZATION (ISO)

- ISO/IEC DIS 17025 - General requirements for the competence of testing and calibration laboratories

(Copies of these documents are available online at <https://www.iso.ch/>.)

NCSL INTERNATIONAL

- NCSL Z540.3 - Requirements for the Calibration of Measuring and Test Equipment

(Copies of these documents are available online at <https://www.ncsli.org/>.)

NORTH ATLANTIC TREATY ORGANIZATION

- AFLP-3747 - Guide Specifications (Minimum Quality Standards) For Aviation Turbine Fuels (F-24, F-27, F-34, F-35, F-37, F-40 and F-44)

(Copies of this documents are available from <https://quicksearch.dla.mil/>.)

MIL-DTL-8794F
w/AMENDMENT 5

SAE INTERNATIONAL

SAE-AMS-STD-595/13538	-	Yellow Gloss
SAE-AMS2629	-	Fluid, Jet Reference
SAE-AS603	-	Impulse Testing of Hydraulic Hose Tubing and Fitting Assemblies
SAE-AS1933	-	Age Controls for Hose Containing Age-Sensitive Elastomeric Material

(Copies of these documents are available online from <https://www.sae.org>.)

UK MINISTRY OF DEFENCE

Defence Standard 91-091 - Turbine Fuel, Kerosene Type, Jet A-1, NATO Code F-35; Joint Service Designation: AVTUR

(Copies of this document are available online from <https://www.ihs.com>.)

2.4 Order of precedence. Unless otherwise noted herein or in the contract, in the event of a conflict between the text of this document and the references cited herein the text of this document takes precedence. Nothing in this document, however, supersedes applicable laws and regulations unless a specific exemption has been obtained.

3. REQUIREMENTS

3.1 Qualification. Hose furnished under this specification shall be products that are authorized by the qualifying activity for listing on the applicable qualified products list before contract award (see 4.5 and 6.3).

3.2 Materials. Hose shall be uniform in quality and free from defects in materials. Materials shall conform to the requirements specified herein. When a specific material is not called out, a material shall be used that will meet the performance requirements of this specification.

3.2.1 Recycled, recovered, environmentally preferable, or biobased materials. Recycled, recovered, environmentally preferable, or biobased materials should be used to the maximum extent possible, provided that the material meets or exceeds the operational and maintenance requirements, and promotes economically advantageous life cycle costs.

3.2.2 Hazardous substances. The use of hazardous substances, toxic chemicals, or ozone depleting chemicals shall be avoided whenever feasible.

3.3 Construction.

3.3.1 Elastomeric inner tube. The portion of the hose that is in contact with the fluids being conveyed shall be a seamless synthetic rubber. The internal surface of the tube shall have a smooth bore and shall be free from pitting. The synthetic rubber shall be hydraulic fluid, fuel, coolant, and oil resistant (see 3.3.8). The inner tube shall be aviation turbine fuel-resistant- NATO F-24 (STANAG/AFLP 3747), JP-5 (MIL-DTL-5624), JP-8 (MIL-DTL-83133), Jet A-1 (Defence Standard 91-091), TS-1 (GOST 10227), and JPTS (MIL-DTL-25524) - see 4.2.1.

MIL-DTL-8794F
w/AMENDMENT 5

3.3.2 Reinforcing material. Hose shall contain a reinforcing wire braid which consists of one fiber braid and one high tensile steel wire braid (corrosion resistant steel (CRES)). The wire braid shall be braided to resist tension so as to provide strength and limit expansion of the hose to a minimum. No length of hose shall contain missing, broken or spliced wire braid or reinforcing material.

3.3.3 Outer cover. The outer cover of the hose shall be oil and fungus resistant. If a fabric is used as the surface material, the material shall be impregnated or fully coated with the elastomeric or cement material.

3.3.4 Vulcanization. The entire construction shall be vulcanized.

3.3.5 Operating temperature. Hose shall be capable of operating in ambient temperatures as specified in [table I](#).

TABLE I. Hose temperature application.

Hose size	Application/operating temperature range <u>1/</u>		
	Hydraulic	Fuel	Oil
-3	N/A <u>2/</u>		
-4	-65°F to +275°F		
-5	(-53.9°C to 135°C)		
-6		-65°F to 160°F	-65°F to 250°F
-8	-65°F to +160°F	(-53.9°C to 71.1°C)	(-53.9°C to 121.1°C)
-10	(-53.9°C to 71.1°C)		
-12			
-16			
-20			
-24	-40°F to 160°F	-40°F to 160°F	-40°F to 160°F
-32	(-40°C to 71.1°C)	(-40°C to 71.1°C)	(-40°C to 71.1°C)
-40			
-48			

1/ Temperature range - ambient and internal fluid.

2/ Size -3 shall not be used in hydraulic applications.

3.3.6 Operating pressure. Hose shall withstand the operating pressures specified in [table II](#) without leakage or evidence of imperfections.

MIL-DTL-8794F
w/AMENDMENT 5

TABLE II. Performance requirements of hose assemblies. 1/

Size (dash number)	Length of hose assemblies for all tests (inches) 2/	Minimum bend radius at inside of bend (inches)	Hydraulic		Fuel		Oil			Burst pressure (psi)
			Operating pressure (psi)	Proof pressure (psi)	Operating pressure (psi)	Proof pressure (psi)	Operating pressure (psi)	Surge pressure (psi)	Proof pressure (psi)	
-3 3/	14	3	N/A	N/A	1,000	1,500	50	400	600	4,000
-4	14	3	3,000	6,000	1,000	1,500	50	400	600	12,000
-5	16	3.375	3,000	6,000	1,000	1,500	50	400	600	12,000
-6	18	4	2,000	4,500	1,000	1,500	50	400	600	9,000
-8	21	4.625	2,000	4,000	1,000	1,500	50	400	600	8,000
-10	23.5	5.5	1,750	3,500	1,000	1,500	50	400	600	7,000
-12	27.5	6.5	1,500	3,000	1,000	1,500	50	400	600	6,000
-16	18	7.375	800	1,600	750	1,000	50	400	600	3,200
-20	18	9	600	1,250	500	750	50	400	600	2,500
-24	18	11	500	1,000	250	375	50	400	600	2,000
-32	18	13.25	350	700	200	300	50	400	600	1,400
-40	18	24	N/A	N/A	200	300	N/A	N/A	N/A	1,000
-48	18	33	N/A	N/A	200	300	N/A	N/A	N/A	800

1/ Assembled with adapters in accordance with MIL-DTL-5070.

2/ Except as otherwise specified in the individual test description.

3/ Size -3 shall not be used in hydraulic applications.

3.3.7 Hose assembly. Hose shall be installed with MIL-DTL-5070 adapters in accordance with MIL-DTL-8795 hose assembly specification.

3.3.8 Fluids. Hose shall be used with petroleum based, synthetic based, or hydrocarbon based hydraulic fluids, pneumatic, coolant, fuels, and oils.

3.3.9 Cleanliness. The interior surface of the hose shall be free from oil, grease, dirt, moisture, cleaning solvents and foreign materials.

3.4 Dimensions.

3.4.1 Diameters. The inside and outside diameters shall be as specified on [figure 1](#).

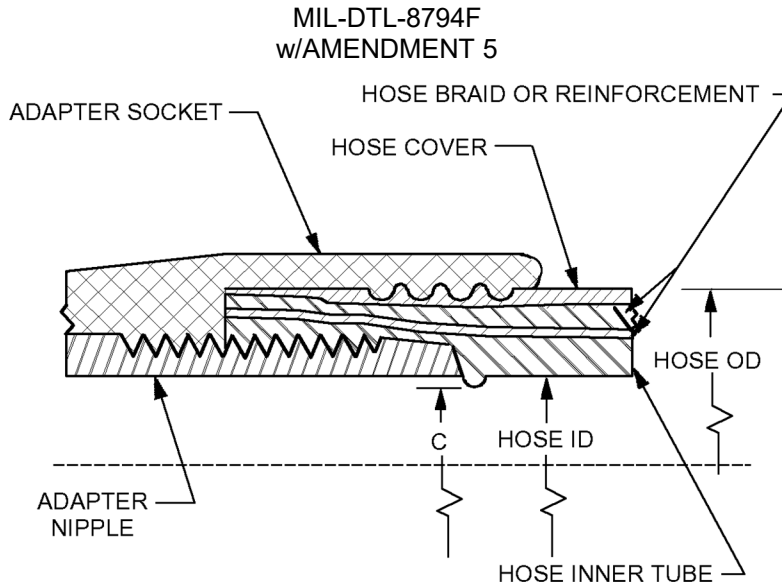

Hose size dash number	Adapter size dash number	ID of hose				OD of hose inch (mm)		C Minimum diameter (see note 3) inch (mm)
		fraction inch	decimal inch	mm	Tolerance inch (mm)			
-3	-3	1/8	.125	3.18	+0.019 (0.48) -0.000	.453 (11.51)	+0.023 (0.58) -0.016 (0.41)	.080 (2.03)
-4	-4	3/16	.188	4.78	+0.026 (0.66) -0.000	.516 (13.11)		.132 (3.35)
-5	-5	1/4	.250	6.35	+0.031 (0.79) -0.000	.578 (14.68)		.200 (5.08)
-6	-6	5/16	.313	7.95		.672 (17.07)	.260 (6.60)	
-8	-8	13/32	.406	10.31	+0.039 (0.99) -0.000	.766 (19.46)	±0.023 (0.58)	.350 (8.89)
-10	-10	1/2	.500	12.70		.922 (23.42)		.450 (11.43)
-12	-12	5/8	.625	15.88	+0.042 (1.07) -0.000	1.078 (27.38)	±0.031 (0.79)	.575 (14.61)
-16	-16	7/8	.875	22.23	+0.047 (1.19) -0.000	1.234 (31.34)		.781 (19.84)
-20	-20	1 - 1/8	1.125	28.58		1.500 (38.10)	1.015 (25.78)	
-24	-24	1 - 3/8	1.375	34.93		1.750 (44.45)	1.250 (31.75)	
-32	-32	1 - 3/16	1.813	46.05	+0.062 (1.57) -0.000	2.219 (56.36)	±0.047 (1.19)	1.719 (43.66)
-40	-40	2 - 3/8	2.375	60.33		2.875 (73.03)		2.178 (55.32)
-48	-48	3	3.000	76.20		3.563 (90.50)		2.803 (71.20)

See notes at end of figure.

FIGURE 1. Hose construction.

MIL-DTL-8794F
w/AMENDMENT 5

NOTES:

1. Dimensions are in inches
2. Metric equivalents are given for information only.
3. C diameter indicates maximum permissible bulge of inner synthetic rubber tube when hose is assembled with adapters.

FIGURE 1. Hose construction - Continued.3.4.2 Concentricity.

3.4.2.1 Concentricity (hose sizes -3 through -8). The outer surface of the hose shall be concentric with the inside bore of the synthetic rubber tube within .020 inch (0.05 mm) total indicator reading. The variation in concentricity between the inside bore of the synthetic rubber tube and the OD of the reinforcing material shall not exceed these same values.

3.4.2.2 Concentricity (hose sizes -10 through -48). The outer surface of the hose shall be concentric with the inside bore of the synthetic rubber tube within .030 inch (0.08 mm) total indicator reading. The variation in concentricity between the inside bore of the synthetic rubber tube and the OD of the reinforcing material shall not exceed these same values.

3.4.3 Length of bulk hose.

3.4.3.1 B designator of bulk hose lengths. Bulk hose shall be furnished in lengths greater than 20 feet (6.10 m). However, up to 10% of the order may be furnished in random lengths between 10 and 20 feet (3.05 to 6.10 m). No more than 10% of the order shall be furnished in random lengths between 3 and 10 feet (0.91 to 3.05 m).

3.4.3.2 S designator for specific bulk hose lengths. When the order is for a specific length in feet, a tolerance of $\pm 1\%$ of the required length shall be used.

3.5 Performance.3.5.1 Materials performance.

3.5.1.1 Tensile strength and elongation of rubber. When tested as specified in 4.8.2, the tensile strength shall be a minimum of 2200 psi (16.17 MPa) and the elongation shall be a minimum of 200%.

3.5.1.2 Adhesion (hose size -12 through -48). When tested as specified in 4.8.3, strip specimens shall be tested for adhesion between the inner tube and inner cotton braid, and inner cotton braid and wire braid. The synthetic rubber tube and the inner layer of reinforcing material, and between layers of reinforcing material, shall be at least 10 pounds per inch, and 5 pounds per inch for an oil aged sample.

3.5.2 Synthetic rubber tube performance.

3.5.2.1 Resistance to coolant. After exposure to coolant as specified in 4.8.4, the synthetic rubber tube tensile strength shall not exceed 35 percent, based on the original cross-sectional area of the synthetic rubber tube, see 3.5.1.1.

MIL-DTL-8794F
w/AMENDMENT 5

3.5.2.2 Fuel resistance. After exposure to fuel, the tensile strength of the synthetic rubber tube shall not be less than 1,000 psi (69 bar) when tested as specified in 4.8.5, the elongation shall be not less than 100 percent, and the volume increase shall not exceed 30 percent for hose sizes -12 and smaller, and shall not exceed 60 percent for hose sizes greater than size -12.

3.5.3 Proof pressure. Hose when as specified in 4.8.6, shall withstand the applicable hydraulic proof pressures specified in table II without leakage or evidence of imperfections.

3.5.4 Reduction in diameter. Hose when tested as specified in 4.8.7, the ID of the hose shall not decrease to less than 90 percent of the minimum ID specified on figure 1.

3.5.5 Impulse test.

3.5.5.1 Impulse test (hose assemblies of sizes -4 through -16). Hose assemblies sizes -4 through -16 when tested as specified in 4.8.8, shall withstand not less than 200,000 dynamic hydraulic impulse cycles, at a nominal rate of 70 pulses per minute at 125 percent of the hydraulic operating pressure specified in table II, without leakage, deformation, or separation from an adapter.

3.5.5.2 Impulse test (hose assemblies of sizes -20 through -32). Hose assemblies of sizes -20 through -32 when tested as specified in 4.8.8, shall withstand not less than 100,000 dynamic hydraulic impulse cycles, at a nominal rate of 70 pulses per minute at 100 percent of the hydraulic operating pressure specified in table II, without leakage, deformation, or separation from an adapter.

3.5.6 Collapse test (hose sizes -3 through -10). Hose sizes -3 through -10 when tested as specified in 4.8.9, shall not collapse to less than the minimum clearance specified in table III. There shall be no ply separation, blistering, or other damage, when subjected to an internal vacuum of 28 inches of mercury (711.2 mm of mercury).

TABLE III. Minimum clearance for collapse test.

Hose size (Dash No.)	Clearance $\pm .001$ inch (± 0.03 mm) inch (mm)
-3	.070 (1.78)
-4	.125 (3.18)
-5	.188 (4.78)
-6	.250 (6.35)
-8	.343 (8.71)
-10	.406 (10.31)

3.5.7 Bending and vacuum.

3.5.7.1 Bending and vacuum test (hose sizes -3 through -24). Hose sizes -3 through -24 when tested as specified in 4.8.10, shall exhibit no more than an additional 10 percent reduction in OD the hose, after bending to 180° at the minimum bend radius specified in table II at any section when an internal vacuum of 28 inches of mercury (711.2 mm of mercury) is applied.

MIL-DTL-8794F
w/AMENDMENT 5

3.5.7.2 Bending and vacuum hose sizes -32 and larger. Hose sizes -32 and larger when tested as specified in 4.8.10, shall exhibit no more than an additional 25 percent reduction in OD the hose, after bending to 180° at the minimum bend radius specified in table II at any section when an internal vacuum of 28 inches of mercury (711.2 mm of mercury) is applied.

3.5.8 Elongation and contraction (hydrostatic pressure test). Hose when tested as specified in 4.8.11, shall not change in length more than +2 or -4 percent at the applicable hydraulic operating pressures specified in table II.

3.5.9 Corrosion resistance. When tested as specified in 4.8.12, the hose shall resist corrosion by aqueous salt atmosphere.

3.5.10 Burst pressure. Hose when tested as specified in 4.8.13, shall not burst or cause adapters to loosen or separate from the hose, and there shall be no external leakage from the hose or hose-to-adapter interface, at any pressure up to the burst pressure specified in table II.

3.5.11 Low temperature flexing.

3.5.11.1 Low temperature flexing (hose sizes -3 through -12). Hose sizes -3 through -12 when tested as specified in 4.8.14, shall be capable of being flexed through 180° of bend in 3 to 5 seconds to the bend radius specified in table I at -65 °F (-53.9°C) without leakage.

3.5.11.2 Low temperature flexing (hose sizes -16 and larger). Hose sizes -16 and larger shall be capable of being flexed through 180° of bend in 3 to 5 seconds to the bend radius specified in table I at -40°F (-40°C) without leakage.

3.5.12 Bulge. When tested as specified in 4.8.15, the bulge of the synthetic rubber tube of the hose when assembled with adapters in accordance with MIL-DTL-5070 shall not reduce the ID of the hose to less than the C dimension shown on figure 1.

3.5.13 Fuel immersion. When tested as specified in 4.8.16, the hose and the hose-to-adapter interface shall not leak after immersion in fuels. The hose shall be visually inspected and there shall be no indication of disintegration, such as ply separation, solubility of component parts, porosity, blistering, or collapse.

3.5.14 Lubricating oil circulation.

3.5.14.1 Lubricating oil circulation (hose size -3 through -12). Hose size -3 through -12 when tested as specified in 4.8.17, shall be capable of circulating oil at fluid temperatures up to 250°F (121.1°C) and under surge conditions of 325°F (162.8°C) without leakage operating at the oil operating pressures specified in table II.

3.5.14.2 Lubricating oil circulation (hose size -16 and larger). Hose size -16 and larger when tested as specified in 4.8.17, shall be capable of circulating oil at fluid temperature up to 160°F (71.1°C) and under surge conditions of 325°F (162.8°C) without leakage while operating at the oil operating pressures specified in table II.

MIL-DTL-8794F
w/AMENDMENT 53.5.15 Volumetric expansion.

3.5.15.1 Volumetric expansion (hose size -3, -4, and -5). Hose size -3 and -4 when tested as specified in 4.8.18, shall be not greater than .06 cubic centimeter per inch of free length at 1,000 pounds per square inch (psi) pressure. The volumetric expansion of size -5 hose when tested as specified in 4.8.18, shall be not greater than .08 cubic centimeter per inch of free length at 1,000 psi (68.9 bar) pressure.

3.5.15.2 Volumetric expansion (hose size -6 and larger). There are no volumetric expansion limits for size -6 hose and larger.

3.5.16 Leakage. Hose assemblies when tested as specified in 4.8.19, shall have no leakage of the hose or from the hose-to-adapter interface, and no seepage back through the fabric that might produce separation or swelling of the hose, when subjected to 70 percent of the burst pressure specified in table II.

3.6 Marking. The outer cover of bulk hose or hose in hose assemblies shall be marked with, continuous yellow stripe. As a minimum, the hose cover material shall be marked with the following information at intervals of not more than 12 inches (305 mm).

- a. PIN as specified in 1.2, length designator may be omitted.
- b. Cure date in quarter and year such as 4Q06 for fourth quarter 2006.
- c. CAGE code.
- d. Manufacturer's name or trademark.

(Example: "MIL-DTL-8794-6-2Q06-00TBD" designates hose size -6 manufactured during the second quarter of calendar year 2006 by the manufacturer whose CAGE Code is 00TBD.)

3.6.1 Marking color. The marking color shall be yellow in accordance to SAE-AMS-STD-595/13538. The marking shall be a water resistant, gasoline resistant, and oil-resistant.

3.7 Workmanship. Hose shall be manufactured and processed in such a manner as to be uniform in quality and shall be free from foreign material and other defects that will affect life, serviceability, strength, assembly or durability, see table IV. Workmanship shall be such as to enable the hose to meet the applicable performance requirements of this specification.

3.8 Age limit. The age limit of bulk hose and hose assemblies covered by this specification and furnished for use by the Government shall not exceed the limits in accordance with SAE-AS1933.

MIL-DTL-8794F
w/AMENDMENT 5
TABLE IV. Workmanship defects.

Defect	Inspection	Reference
Misbranding	Visual	3.6
Age limit	Visual	3.8
Dimensions affecting interchangeability not within tolerance	Standard inspection equipment	3.4
Ridge on tube - Severe	Standard inspection equipment	N/A
Bunching of tube - Severe	Standard inspection equipment	N/A
Loose tube	Standard inspection equipment	N/A
Off center -under gage cover	Standard inspection equipment	N/A
Hole in tube	Standard inspection equipment	N/A
Nad lap or delamination of tube	Standard inspection equipment	N/A
Reinforcement through tube	Standard inspection equipment	N/A
Reinforcement through cover	Visual	N/A
Poorly patched cover	Visual	N/A
Blistered or loose, patch on cover	Visual	N/A
Under gage cover area	Visual	N/A
Poor overlap, opening or lack of adhesion	Visual	N/A
Cover missing	Visual	3.3.3
Loose cover (wrinkles when bent)	Visual	N/A
Exposed reinforcement braid	Visual	3.3.2
Split, slit or break in cover	Visual	N/A
Blister under cover	Visual	N/A

4. VERIFICATION

4.1 Classifications of inspection. The inspection requirements specified herein are classified as follows:

- a. Qualification inspection (see 4.5).
- b. Conformance inspection (see 4.6).

4.2 Test equipment and inspection facilities. Test and measuring equipment and inspection facilities of sufficient accuracy, quality and quantity to permit performance of the required inspection shall be used. The establishment and the maintenance of a calibration system to control the accuracy of all test and measuring equipment shall be in accordance with ISO/IEC DIS 17025 and NCSL Z540.3 as applicable.

4.2.1 Aviation test fluids. SAE-AMS2629 shall be the test fluid; it serves as surrogate test fluid for all of the applicable aviation turbine fuels (F-24, JP-5, JP-8, Jet A-1, TS 1, and JPTS) listed in this specification. Should SAE AMS2629F not be available, NATO F-24, as described in AFLP 3747, is an acceptable alternative test fluid.

MIL-DTL-8794F
w/AMENDMENT 5

4.3 Responsibility for compliance. All items shall meet all requirements of sections 3 and 4. The inspection set forth in this specification shall become a part of the contractor's overall inspection system or quality program. The absence of any inspection requirements in the specification shall not relieve the contractor of the responsibility of ensuring that all products or supplies submitted to the Government for acceptance comply with all requirements of the contract. Sampling inspection, as part of manufacturing operations, is an acceptable practice to ascertain conformance to requirements, however, this does not authorize submission of known defective material, either indicated or actual, nor does it commit the Government to accept defective material.

4.4 Hose assemblies for hose testing. The hose assemblies used for hose testing shall be assembled using adapters in accordance with MIL-DTL-5070 of the applicable size in accordance with the adapter manufacturer's instructions (see MIL-DTL-8795 and MS28741). Hose assemblies shall be examined to verify that there has been no degradation of the hose or adapters resulting from the assembly process. Unless otherwise specified, hose assembly lengths shall be as specified in [table II](#).

4.5 Qualification inspection. Qualification inspection shall be performed at a laboratory acceptable to the qualifying activity on sample units produced with equipment and procedures used in production. Each nominal hose size (ID) shall be qualified individually.

4.5.1 Samples for qualification. Samples for qualification shall be representative of the products proposed to be furnished to the Government. Samples shall be of one type and nominal size of hose and shall be of the quantity and length specified in the applicable test method.

4.5.2 Qualification inspection routine. All samples shall be subjected to qualification testing as specified in [table V](#) and the test sequence as specified in [table VI](#).

4.5.3 Disposition of test specimens. Test specimens that have been subjected to qualification testing shall not be delivered on a contract or purchase order.

MIL-DTL-8794F
w/AMENDMENT 5

TABLE V. Qualification inspection.

Inspection	Requirement paragraph	Test method paragraph	Sample type
Tensile (tension) properties			
Tensile strength and elongation	3.5.1.1	4.8.2	Sample hose cover and tube
Adhesion	3.5.1.2	4.8.3	Strip
Synthetic rubber tube properties			
Coolant resistance	3.5.2.1	4.8.4	Tube
Fuel resistance	3.5.2.2	4.8.5	Tube
Hose and hose assemblies			
Visual inspection	3.3, 3.4, 3.6, 3.7, and 3.8	4.8.1	Hose
Cleanliness	3.3.9	---	Hose
Proof pressure	3.5.3	4.8.6	Hose assembly
Reduction in diameter	3.5.4	4.8.7	Hose
Impulse	3.5.5	4.8.8	Hose assembly
Collapse	3.5.6	4.8.9	Hose assembly
Bending and vacuum	3.5.7	4.8.10	Hose assembly
Elongation and contraction	3.5.8	4.8.11	Hose assembly
Corrosion resistance	3.5.9	4.8.12	Hose assembly
Burst pressure	3.5.10	4.8.13	Hose assembly
Low temperature flexing	3.5.11	4.8.14	Hose assembly
Bulge	3.5.12	4.8.15	Hose assembly
Fuel Immersion	3.5.13	4.8.16	Hose assembly
Lubricating oil circulation	3.5.14	4.8.17	Hose assembly
Volumetric expansion	3.5.15	4.8.18	Hose assembly
Leakage	3.5.16	4.8.19	Hose assembly

MIL-DTL-8794F
w/AMENDMENT 5
TABLE VI. Qualification test sequence.

Hose or hose assembly number	Hose assembly type	Test sequence				
N/A	Strip specimen	4.8.2				
N/A		4.8.3				
N/A	Inner tube	4.8.1 ^{1/}	4.8.4			
N/A		4.8.1 ^{1/}	4.8.5			
1 and 2	Hose	4.8.7				
3 through 9	Hose assembly	4.8.1	4.8.6	4.8.8		
10		4.8.1	4.8.6	4.8.9		
11		4.8.1	4.8.6	4.8.10		
12 and 13		4.8.1	4.8.6	4.8.11	4.8.12	4.8.13
14 and 22		4.8.1	4.8.6	4.8.14		
23 through 15		4.8.1	4.8.6	4.8.15		
16		4.8.1	4.8.6	4.8.16		
17		4.8.1	4.8.6	4.8.17		
18		4.8.1	4.8.6	4.8.18		
19		4.8.1	4.8.6	4.8.19		

^{1/} Visual inspection, see 3.3.1.

4.5.3 Acceptance of qualification inspection data. Required qualification tests at the hose assembly level that were already performed at the bulk hose level may be waived if documented approval has been obtained from the qualifying activity.

4.5.4. Failures. One or more failures shall be cause for refusal to grant qualification.

4.5.5 Test plans and qualification reports.

4.5.5.1 Test plans. Test plans shall be prepared and submitted in accordance with the requirements of the qualification activity. The method of qualification proposed by the contractor is subject to the approval of the qualification activity. Manufacturers shall discuss with the qualifying activity the test specimens and test plans. These plans shall state specifically the component requirement to be verified during the test, such as test fixtures, setup, conditions, and identification of the successor failure criteria shall be included as appropriate.

4.5.5.2 Qualification reports. Qualification reports shall be submitted in accordance with requirements of the qualifying activity. The visual and mechanical inspection and the hose assembly fitting inspection will be 100% unless another sampling plan is approved in writing by the qualifying activity.

4.6 Conformance inspection.

4.6.1 Individual inspection. Individual inspection shall consist of the inspections specified in table VII in the order shown.

MIL-DTL-8794F
w/AMENDMENT 5

TABLE VII. Individual inspections.

Inspections	Requirement paragraph	Inspection paragraph
Visual inspection <u>1/</u>	3.3, 3.4, 3.6, 3.7, and 3.8	4.8.1
Proof pressure	3.5.3	4.8.6

1/ 100 percent inspection of the bulk hose length unless an alternate sampling plan is approved in writing by the qualifying activity.

4.6.2 Individual inspections sampling plan. Individual inspection tests specified in table VII shall be performed on a production lot basis. All defective material will be removed from the production lot and shall not be supplied to this specification

4.6.3 Sampling inspection lot.

4.6.3.1 Sampling for bulk hose. Sampling for bulk hose shall be performed on each continuous run under essentially the same conditions. Samples shall be selected at a rate of 1 sample for each full or partial increment of 750 feet (228.60 m) of hose produced in the continuous run, up to a maximum of 2 samples (for continuous runs greater than 1,500 feet (457.20 m), 2 samples shall be selected, but they shall be representative of the entire production run). Sampling tests for length change, leakage, and burst shall be performed in the listed order on each sample as applicable. When a hose assembly is specified in the test method, a hose assembly shall consist of the hose as specified herein, coupled with fittings as specified in 3.3.7.

4.6.4 Sampling and periodic inspections. Sampling and periodic inspections shall consist of the inspections specified in table VIII and shall be performed on test samples selected from production lot(s) that has been subjected to and passed the individual inspections (see table VII).

TABLE VIII. Sampling and periodic inspections.

Inspections	Requirement paragraph	Inspection paragraph	Sampling	Periodic
Elongation and contraction	3.5.8	4.8.11	X	---
Leakage	3.5.16	4.8.19	X	---
Burst pressure	3.5.10	4.8.13	X	---
Impulse <u>1/</u>	3.5.5	4.8.8	---	X
Collapse <u>1/</u>	3.5.6	4.8.9	---	X
Adhesion <u>1/</u>	3.5.1.2	4.8.3	---	X

1/ Aging is not required for periodic inspection.

4.6.4.1 Periodic testing sampling plan.

4.6.4.2 Periodic quality conformance inspection (QCI) (bulk hose) . Four (4) samples, of one hose size, shall be tested to each required periodic test for each production of 20,000 feet (6096 m) (large lot option). At the option of the manufacturer, 1 sample, of one hose size may, be tested to each required periodic test for each production of 5,000 feet (1524 m) as applicable (small lot option).

MIL-DTL-8794F
w/AMENDMENT 5

4.6.4.2.1 Reduced production bulk hose. If there has been some production, but the footage of bulk hose, for one size produced has not reached 5,000 feet (1524 m) within three years, the manufacturer shall perform periodic control tests on one sample of that size, for each required periodic test, unless documented approval to not perform the test has been obtained from the qualifying activity.

4.6.4.3 Periodic samples. Periodic samples may be subjected to more than one periodic test at the discretion of the manufacturer. However, the manufacturer assumes all risk that the effect of one test will not have a detrimental impact on the following tests.

4.6.4.4 Disposition of test specimens. Test specimens that have been subjected to sampling and periodic inspections in [table VIII](#) shall not be delivered on the contract or purchase order.

4.6.5 Nonconformance of sampling and periodic inspections.

4.6.5.1 Failures. If a sample fails to pass sampling and periodic inspections, see [table VIII](#), the manufacturer shall immediately notify the qualifying activity and cognizant inspection activity of such failure. The manufacturer shall take corrective action on the materials or processes or both as warranted, on all units of product which can be corrected and which were manufactured under essentially the same conditions, with essentially the same materials and processes, and which are considered subject to the same failure.

4.6.5.2 Acceptance and shipment. Acceptance and shipment of the product shall be discontinued until corrective action acceptable to the qualifying activity has been taken. After the corrective action has been taken sampling and periodic inspection, see [table VIII](#), shall be repeated on additional samples. At the discretion of the qualifying activity this may include all inspections, or the inspection which the original sample failed. Individual and sampling and periodic inspections, if applicable, may be reinstated. However final acceptance of the hose or hose assemblies shall be withheld until the sampling and periodic inspection has shown that the corrective action was successful.

4.6.6 Additional QPL test and reporting requirements.

4.6.6.1 Retention of qualification. To retain qualification, the contractor shall submit a test report to the qualifying activity at 36-month intervals. The qualifying activity shall establish the initial reporting date. Each report shall consist of a summary of test and inspection results required by this specification that were performed during the 36-month reporting interval. As a minimum, the report shall include the following:

- a. Number of lots produced and tested, including lot and sample sizes for each lot.
- b. Identify which tests were performed.
- c. Quantities passed.
- d. Quantities failed.
- e. All reworked sampling lots shall be accounted for and identified. A summary of corrective action taken shall be included.

4.6.7 Loss of product qualification.

4.6.7.1 Failure to meet test requirements. The manufacturer shall immediately notify the qualifying activity at any time during the 36-month reporting period when the qualified product fails to meet the test and inspection requirements of this specification. The manufacturer shall identify and indicate what corrective action will be taken to correct the problem. Failure to take corrective action acceptable to the qualifying activity may result in removal of the product from the QPL.

MIL-DTL-8794F
w/AMENDMENT 5

4.6.7.2 Failure to submit summary test data report. Failure to submit a report within 30 days after the end of the 36-month reporting period may result in loss of qualification for the product.

4.6.7.3 Change to manufacturing process, materials or equipment. The manufacturer shall notify the qualifying activity, in writing, of any changes in the manufacturing process, materials, or equipment used to manufacture a QPL product. Subsequently, the qualifying activity will notify the manufacturer, in writing, if a full re-qualification, partial re-qualification, or no additional testing is required as a result of these changes.

4.6.7.4 No production during reporting period (36 months). When no production occurs during the reporting period, a report shall be submitted to the qualifying activity, certifying that the manufacturer still has the capability and facilities necessary to produce the QPL product.

4.6.7.5 Discontinuation and resumption of production of bulk hose (three years or more). If there has been no production of a specific hose size for a period of three years or more, samples for each test shall be randomly selected from the first lot produced when production of that size hose has been resumed. Two (2) hose samples shall be subjected to each of the sampling tests and four (4) hose samples shall be subjected to each of the periodic control tests (see table VIII).

4.7 Sample preparation.

4.7.1 Inspection conditions. Unless otherwise specified, all inspections shall be performed in accordance with the test conditions specified in ASTM D380, or in accordance with the applicable test method referenced in the test procedures. Unless otherwise specified, room temperature shall be defined as +60°F to +90°F (15.56°C to 32.22°C).

4.7.1.1 Test fluid. The test fluid shall be coolant in accordance with A-A-52624; lubricating oil in accordance with MIL-PRF-2104, hydraulic fluid in accordance with MIL-PRF-5606, MIL-PRF-87257 or MIL-PRF-83282; or fuel in accordance with SAE-AMS2629, see 4.2.1. -Water is an acceptable test fluid only for the leakage, proof pressure, and burst tests. If water is used, the test article must be thoroughly dried before use in further testing or prior to delivery.

4.7.1.2 Oil-aging. For tests that require a hose assembly to be oil-aged the procedure shall be as follows:

- a. The hose assembly shall be completely immersed in hydraulic fluid within a non-pressurized closed container or reflux condenser (to prevent distillation of the volatile matter in the fluid).
- b. The hose assembly shall be maintained at a temperature of 160°F ± 5°F (71.1°C ± 2.8°C) for 7 days prior to the start of the test.
- c. During the aging period, the bore of the hose assembly shall be open and no air shall be entrapped therein.
- d. No more than 10 hose assemblies shall be aged in a given quantity of test fluid.

4.7.1.3 Air-aging. For tests that require a hose assembly to be air-aged, the hose assembly shall be maintained in air at a temperature of 160°F ± 5°F (71.1°C ± 2.8°C) for 7 days prior to the start of the test.

MIL-DTL-8794F
w/AMENDMENT 54.8 Performance.

4.8.1 Visual inspection. Hose and hose assemblies shall be examined to ensure conformance with this specification and associated specification sheets. Hose and hose assemblies shall be examined to verify that the design, construction and physical dimensions are in accordance with the applicable requirements. Continuous examination shall be performed to assure compliance with the following requirements:

- a. Design, construction, materials, and physical dimensions (see [3.3](#)).
- b. Marking (see [3.6](#))
- c. Workmanship (see [3.7](#))
- d. Age limit (see [3.8](#))

4.8.2 Tensile (tension) properties (see [3.5.1.1](#)). Samples of the hose cover and tube when subjected to the tensile (tension) test in accordance with ASTM D380 shall meet the requirements of [3.5.1.1](#).

4.8.3 Adhesion test (see [3.5.1.2](#)). An unaged and oil aged (see [4.7.1.2](#)) hose specimen shall be tested for adhesion and shall meet the requirements of [3.5.1.2](#). The following details shall apply:

- a. The adhesion test is applicable for hose sizes -12 through -48 only.
- b. Verification of adhesion for hose sizes smaller than -12 may be accomplished on the basis of similarity to larger sizes.
- c. An unaged and an oil-aged (see [4.7.1.2](#)) hose specimen shall be tested for adhesion between the synthetic rubber tube and inner layer of reinforcing material, and between the inner and outer layer of reinforcing material, in accordance with the machine method of ASTM D413 using a type A specimen.
- d. The oil-aged strip specimen shall be tested for adhesion within one hour after removal from the oil-aging fluid.

4.8.4 Resistance to coolant. Inner tube specimens when subjected to resistance to coolant testing shall meet the requirements of [3.5.2.1](#). The following details shall apply:

- a. Specimens shall be in accordance with ASTM D412 or FED-STD-601 method 4111.
- b. Testing shall be in accordance with ASTM D471.
- c. Tube samples shall be immersed in a solution of 60 percent inhibited ethylene glycol antifreeze conforming to type I of A-A-52624, and 40 percent water for 166 hours at 235°F \pm 5°F (113°C \pm 5°C).
- d. The tensile strength shall be measured within 15 minutes after removal from the solution.

4.8.5 Fuel resistance test (synthetic rubber tube) (see [3.5.2.2](#)). The synthetic rubber tube when subjected to immersion testing in accordance with ASTM D380 shall meet the requirements of [3.5.2.2](#). The following details shall apply:

- a. The strength deterioration test samples shall be tested in accordance with ASTM D380, except that the test specimens shall be immersed in fuel in accordance with SAE-AMS2629, for 72 hours at room temperature.
- b. The tensile strength and elongation shall be measured within 5 minutes after removal from the test fluid (see [3.5.2.2](#)).
- c. Specimens of the synthetic rubber tube shall be subjected to the swelling tests in accordance with FED-STD-601, method 6211, except that the specimens shall be immersed for 72 hours at room temperature in fuel in accordance with SAE-AMS2629, and the volume increase shall be measured within 5 minutes after removal from the test fluid.

MIL-DTL-8794F
w/AMENDMENT 5

- d. Specimens shall be dissected longitudinally, and any indication of disintegration such as ply separation, solubility of component parts, porosity, blistering, or collapse shall be cause for rejection.

4.8.6 Proof pressure (see 3.5.3). All hose assemblies shall be proof pressure tested in accordance with ASTM D380 and shall meet the requirements of 3.5.3. The following details shall apply:

- a. Hose assembly shall be unaged.
- b. Hose assemblies shall be subjected to the hydraulic proof pressure, except -3 to fuel proof pressure, specified in [table II](#) for a period of not less than 1 minute.
- c. The hose assembly shall show no evidence of leakage, burst, deformation, movement relative to the hose, or separation from the hose.

4.8.7 Reduction in diameter test (see 3.5.4). The reduction in diameter test shall be conducted on a length of hose 3 inches long that has been oil-aged (see 4.7.1.2) and shall meet the requirements of 3.5.4. The hose shall be measured at least 1/2 inch (12.7 mm) inside the hose from each end.

4.8.8 Impulse test (see 3.5.5). Size -4 through -32 hose assemblies when subjected to impulse testing in accordance with SAE-AS603 shall meet the requirements of 3.5.5. Impulse testing of sizes -3, -40, and -48 is not required. The following details shall apply:

- a. Six hose assemblies of the length specified in [table II](#) shall be subjected to hydraulic impulse testing.
- b. Two assemblies shall be oil-aged (see 4.7.1.2), two shall be air-aged (see 4.7.1.3), and two shall be unaged.
- c. All hose assemblies shall be subjected to and successfully withstand the applicable hydraulic proof pressure specified in [table II](#) prior to impulse testing.
- d. Hose assemblies in sizes -4 through -32 shall be connected to a manifold and installed in an impulse test machine that shall produce dynamic impulses in the manifold of the magnitude and frequency required by SAE-AS603.
- e. For hose assemblies -4 through -16 the peak pressure shall be 125 percent of the hydraulic operating pressure specified in [table II](#). Hose assemblies in size -20 through -32 shall be subjected to a peak pressure of 100 percent of the hydraulic operating pressure specified in [table II](#).
- f. In all cases, the backpressure shall be a maximum of 75 psi.
- g. There shall be no evidence of leakage or separation of the adapter from the hose.
- h. Any retightening of adapters or other maintenance on the adapters or hoses during this test shall be recorded.
- i. The fluid used for this test shall conform to either MIL-PRF-5606, MIL-PRF-87257, or MIL-PRF-83282, except that the test fluid may contain up to 25 percent by volume of lubricating oil in accordance with MIL-PRF-2104.
 - (1) The fluid shall be held to a temperature of 120°F ±10°F (49°C ±5.6°C) measured at the test manifold.
- j. Hose sizes -4 through -12, when installed on the impulse test machine, shall be bent into a “U” shape with a bend radius as specified in [table II](#).
- k. Hose sizes -16 through -32 may be installed straight.
- l. Both ends of the bent hose assembly shall be connected to a rigid support and one end of the straight hose assembly shall be free.
 - (1) Sizes -4 through -16 shall be subjected to 200,000 impulse cycles,
 - (2) Sizes -20 through -32 shall be subjected to 100,000 impulse cycles.
- m. There shall be no evidence of leakage or separation of the hose from the adapter.

MIL-DTL-8794F
w/AMENDMENT 5

4.8.9 Collapse test (hose size -3 through -10 only) (see [3.5.6](#)). A hose assembly when subjected to collapse testing shall meet the requirements of [3.5.6](#). The following details shall apply:

- a. The collapse test shall be conducted on a hose assembly that has been oil-aged as specified in [4.7.1.2](#).
- b. The hose assembly shall not be dried or washed after oil aging, and the test shall be conducted within 1 hour after removal of hose from the oil-aging fluid.
- c. A steel ball, with the diameter specified in table III and adequately perforated to prevent being affected by a vacuum, shall be used as test specimen.
- d. The hose assembly shall be bent over a form to the radius specified in [table II](#) and a vacuum of 28 inches of mercury applied and held for 5 minutes, during which time the hose assembly shall be rotated and re-bent over the form at 90° intervals throughout 360°.
- e. With vacuum still applied, the hose assembly shall be straightened and held in a horizontal position and gradually tilted to 30° in each direction.
- f. The test is passed if the ball rolls through the hose assembly.
- g. After release of the vacuum, the hose shall be dissected longitudinally and examined for evidence of ply separation, blistering, collapse, or other damage (see [3.5.6](#)).

4.8.10 Bending and vacuum test (see [3.5.7](#)). The bending and vacuum test shall be conducted on a hose assembly that has been oil-aged (see [4.7.1.2](#)) and shall meet the requirements of [3.5.7](#). The following details shall apply:

- a. The hose assembly shall be bent over a form to the radius specified in [table II](#) and the OD measured at the flattened section.
- b. While still bent in this radius, a vacuum of 28 inches of mercury (711.2 mm of mercury) shall be applied to the hose assembly and held for 5 minutes, during which time the hose shall be checked for additional flattening.
- c. After release of the vacuum, the hose shall be dissected longitudinally and examined for evidence of ply separation, blistering, collapse, or other damage.
- d. All sizes of hose shall not flatten or otherwise deform at any section in an amount greater than 10 percent reduction in OD (25 percent for size -32) before the vacuum is applied.
- e. This test does not apply to hose sizes -40 and -48.

4.8.11 Elongation and contraction (see [3.5.8](#)). The elongation and contraction shall be tested as specified in ASTM D380 and meets as specified in [3.5.8](#). The following details shall apply:

- a. Test specimens shall consist of three hose assemblies, each not less than 18 inches (457 mm) between fittings.
- b. Test pressure shall be the hydraulic operating pressure specified in [table II](#) for the type and size hose tested.
- c. Average change in length of the three specimens, expressed in percentage of the original length, shall be calculated and used as specified in [3.5.8](#).

4.8.12 Corrosion resistance test (see [3.5.9](#)). A hose assembly subjected to the corrosion resistance test shall meet the requirements of [3.5.9](#). The following details shall apply:

- a. With the ends plugged, the hose assembly shall be immersed in a vertical position into a 2.5 percent aqueous solution of sodium chloride for a period of 5 minutes.
- b. The hose assembly shall then be air-dried for 25 minutes at a temperature of 140± 5 °F (60°C ± 5°C).
- c. This immersion and drying cycle shall be repeated for a total of 168 hours.
- d. Upon completion of this test, the hose assembly shall be subjected to the applicable burst pressure as specified in [4.8.13](#).

MIL-DTL-8794F
w/AMENDMENT 5

4.8.13 Burst pressure test (see 3.5.10). A hose assembly when subjected to burst pressure testing in accordance with ASTM D380 shall meet the requirements of 3.5.10. The following details shall apply:

- a. The hose assembly shall be subjected to the burst pressure of [table II](#).
- b. The test shall be conducted using water or hydraulic fluid as the test fluid, except that pressure shall be applied at a rate between 15,000 psi (1034 bar) and 25,000 psi (1724 bar) per minute.
- c. The hose shall not leak or burst and the adapter shall not separate from the hose at pressures up to the burst pressure of [table II](#).

4.8.14 Low temperature flexing (see 3.5.11). Hose assemblies when subjected to the low temperature flexing shall meet the requirements of 3.5.11. The following details shall apply:

- a. Two hose assemblies shall be subjected to the cold temperature flexing test.
- b. For hose sizes -16 and larger, the hose assembled with adapters shall be 30 inches in length.
- c. One assembly shall be oil-aged (see [4.7.1.2](#)), and the other assembly shall be air-aged (see [4.7.1.3](#)).
- d. These assemblies shall be placed in a cold chamber, the temperature of which shall be -65°F, -5°F/+0 °F (-53.9°C, -2.8°C/+0°C).
 - (1) Hose assemblies of size -16 and larger may be tested at -40°F (-40°C) in lieu of -65 F (-53.9°C).
- e. After this time, and while still at the specified temperature, the two assemblies shall be removed from the cold chamber and immediately each assembly shall be flexed through 180° to the bend radius, specified in [table II](#), in 3 to 5 seconds.
- f. The hose assemblies shall then be subjected to the applicable hydraulic proof pressure in accordance with [4.8.6](#), after removal from the cold temperature flexing test.

4.8.15 Bulge test (see 3.5.12). Hose assemblies when subjected to bulge testing shall meet the requirements of 3.5.1.2. The hose assemblies shall be measured for bulging of the synthetic rubber tube and resulting reduction of ID caused by the attachment of the hose to the adapter. The following details shall apply:

- a. The hose shall be conditioned in air at a temperature of 160°F ±5°F (71.1°C ±2.8°C) for a minimum of 16 hours prior to assembly.
- b. The hose and adapters shall be assembled in accordance with procedures recommended by the adapter manufacturer for hand assembly and the bulge measured.
- c. The hose assembly shall then be oil aged (see [4.7.1.2](#)) for 7 days for qualification inspection (20 to 24 hours for conformance inspection) and the bulge again measured.
- d. A ball-end-type gauge is recommended for the bulge measurement.
- e. If used, the diameter of the ball type gauge shall be within .001 inch (0.03 mm) of the minimum bulge diameter C shown on [figure 1](#).
- f. Holding the hose in a vertical position, the gauge is inserted into the end of the hose assembly at the bulge inspection point C shown on [figure 1](#).
- g. The gauge must fall through the section at the end of the adapter insert under its own weight without lubrication and without forcing the gauge through the adapter-to-hose interfacing section.
- h. The weight of the gauge shall be equal in ounces to the dash number of the hose for which designed (see [figure 1](#)).

MIL-DTL-8794F
w/AMENDMENT 5

4.8.16 Fuel immersion test (hose assembly) (see 3.5.13). Hose assembly when subjected to fuel immersion test shall meet the requirements of 3.5.13. The following details shall apply:

- a. A hose assembly having 9 inches (229 mm) of free hose between the adapters shall be immersed in fuel in accordance with SAE-AMS2629 for 72 hours at room temperature.
- b. Upon completion of this period, the assembly shall be subjected to the proof pressure specified (see 4.8.2) for fuel in table II and held for 5 minutes.
- c. The test fluid used for pressure checking shall be lubricating oil in accordance with MIL-PRF-2104, or MIL-PRF-5606, MIL-PRF-87257 or MIL-PRF-83282 hydraulic fluid.
- d. The hose shall then be dissected longitudinally and visually inspected as specified in 3.5.13.

4.8.17 Lubricating oil circulation test (see 3.5.14). A hose assembly subjected to lubricating oil circulation testing shall meet the requirements of 3.5.14. The following details shall apply:

- a. The test fluid used for this test shall be lubricating oil in accordance with MIL-PRF-2104, or hydraulic fluid in accordance with MIL-PRF-5606, MIL-PRF-87257 or MIL-PRF-83282.
- b. A hose assembly smaller than size -24 shall have 9 inches (229 mm) of free-length hoses between adapters. For a hose assembly of size -24 and larger, the ratio of free length hose between adapters to the nominal hose size in inches shall be six to one. The following sequence of steps shall be performed:
 - (1) The hose assembly shall be filled with test fluid while at room temperature. The hose assembly shall remain filled for the duration of the test.
 - (2) The hose assembly shall be installed in a temperature-controlled box.
 - (3) The temperature of the ambient air shall be reduced to $-40^{\circ}\text{F} \pm 5^{\circ}\text{F}$ ($-40^{\circ}\text{C} \pm 2.8^{\circ}\text{C}$) and held for a minimum of 3 hours.
 - (4) Circulation of the fluid shall then be started at the specified operating pressure for oil in table II at a minimum flow rate of 3 gallons per minute.
 - (5) A 400 psi (27.6 bar) surge pressure shall be applied for the first 30 seconds of fluid circulation while the ambient temperature is at -40°F (-40°C).
 - (6) The temperature of the fluid shall then be increased within 1 hour to the specified circulation temperature of $250^{\circ}\text{F} \pm 5^{\circ}\text{F}$ ($121.1^{\circ}\text{C} \pm 2.8^{\circ}\text{C}$). The ambient air temperature shall be increased to $140^{\circ}\text{F} \pm 10^{\circ}\text{F}$ ($60^{\circ}\text{C} \pm 5.6^{\circ}\text{C}$).
 - (7) Circulation shall be continued for a minimum of 20 hours.
 - (8) The temperature of the fluid shall be raised to 325°F , $+0$, -5°F (162.8°C , $+0$, -5°C), for 15 minutes during the last 30 minutes of each 20-hour cycle.
 - (9) The ambient air temperature shall be maintained at $140^{\circ}\text{F} \pm 10^{\circ}\text{F}$ ($60^{\circ}\text{F} \pm 5.6^{\circ}\text{C}$).
 - (10) Fluid circulation shall then be stopped.
 - (11) Steps 1, 2, and 3 shall be accomplished a total of 10 times to obtain a minimum of 200 hours fluid circulation.
 - (12) Upon completion of the above test sequence, the hose assembly shall be subjected to a proof pressure test at the pressure (see 4.8.6) specified for oil in table II and held for 5 minutes.

4.8.18 Volumetric expansion test (see 3.5.15) (Hose size -3, -4, and -5 only). Hose shall be subjected to the volumetric expansion test of ASTM D380 and shall meet the requirements of 3.5.15.

MIL-DTL-8794F
w/AMENDMENT 5

4.8.19 Leakage test (see 3.5.16). A hose assembly when subjected to the leakage test in accordance with ASTM D380 shall meet the requirements of 3.5.16. The following details shall apply:

- a. The hose assembly shall be subjected to 70 percent of the burst pressure shown in table II and held for 5 minutes using water or hydraulic fluid as the test fluid.
- b. The pressure shall then be reduced to 0 psi, after which the pressure shall again be raised to 70 percent of the burst pressure and held for an additional 5 minutes.
- c. The surface of the hose shall be carefully checked during this period for any wicking or leakage of the test fluid that might indicate leakage of the hose.

5. PACKAGING

5.1 Packaging. For acquisition purposes, the packaging requirements shall be as specified in the contract or order (see 6.2). When packaging of materiel is to be performed by DoD or in-house contractor personnel, these personnel need to contact the responsible packaging activity to ascertain packaging requirements. Packaging requirements are maintained by the Inventory Control Point's packaging activities within the Military Service or Defense Agency, or within the military service's system commands. Packaging data retrieval is available from the managing Military Department's or Defense Agency's automated packaging files, CD-ROM products, or by contacting the responsible packaging activity.

6. NOTES

(This section contains information of a general or explanatory nature that may be helpful, but is not mandatory.)

6.1 Intended use. The hose when assembled to MIL-DTL-5070 adapters are used in aircraft for hydraulic, fuel and engine oil system hose assemblies in accordance with MIL-DTL-8795. Other hose assemblies utilizing this hose with the proper firesleeving may be used within fire zones. This hose is intended for use in systems with an operating environment from -65°F to +250°F.

6.1.1 Military unique rationale. The rubber hose assemblies described by this specification require qualification (material, part, and process), and on site audits, which include traceability of parts. The rubber hose assemblies must be capable of interoperability and compatibility which can only be assured through strict adherence to the detail specification sheet requirements. Commercial parts are not designed to be interchangeable with aircraft hydraulic, fuel, or oil systems.

6.2 Acquisition requirements. Acquisition documents should specify the following:

- a. Title, number, and date of this specification.
- b. PIN (see 1.2)
- c. Packaging requirements (see 5.1).
- d. Shelf life requirements (see 6.2.1).

6.2.1 Shelf life. This specification covers items where the assignment of a Federal shelf-life code is a consideration. Specific shelf-life requirements should be specified in the contract or purchase order, and should include, as a minimum, shelf-life code, shelf-life code, shelf-life package markings in accordance with MIL-STD-129 or FED-STD-123, preparation of a materiel quality storage standard for type II (extendible) shelf-life items, and a minimum of 85 percent shelf-life remaining at time of receipt by the Government. These and other requirements, if necessary, are in DoD4140.27-M, *Shelf-life Management Manual*. The shelf-life codes are in the Federal Logistics Information System Total Item Record. Additive information for shelf-life management may be obtained from DoD 4140.27-M, or the designated shelf-life Points of Contact (POC). The POC should be contacted in the following order: (1) the Inventor Control Points that manage the item and (2) the DoD Service and Agency administrators for the DoD Shelf-Life

MIL-DTL-8794F
w/AMENDMENT 5

Program. Appropriate POCs for the DoD Shelf-Life Program can be contacted through the DoD Shelf-Life Management website: <https://www.shelflife.dla.mil/>.

6.3 Qualification. With respect to products requiring qualification, awards will be made only for products which are, at the time of award of contract, qualified for inclusion in Qualified Products List QPL No.8794 whether or not such products have actually been so listed by that date. The attention of the contractors is called to these requirements, and manufacturers are urged to arrange to have the products that they propose to offer to the Federal Government tested for qualification in order that they may be eligible to be awarded contracts or orders for the products covered by this specification. Information pertaining to qualification of products may be obtained from DLA Land and Maritime, P.O. Box 3990, ATTN: VQ, Columbus, Ohio 43218-3990 or emailed to vqc.chief@dla.mil. An online listing of products qualified to this specification may be found in the Qualified Products Database (QPD) at <https://assist.dla.mil>.

6.4 FAA - Technical Standard Orders Authorization (TSOA). A TSOA is a process within FAA, where they adopt a standard document and authorize a manufacturer to make that part at the minimum performance standard for specified materials, parts, and appliances used on civil aircrafts. When authorized to manufacture a material, part or appliances to a TSO standard, this is referred to as a TSO authorization. Receiving a TSO authorization is both design and production approval.

Receiving a TSO authorization is not an approval to install or use the article in the aircraft. It means that the article meets the specific TSO and applicant is authorized to manufacture it. The TSO associated with this document is TSO-C53a.

6.5 Definitions.

- a. NATO F-24: Jet A commercial aviation turbine fuel meeting ASTM D1655 additized with the military fuel additive package for JP-8 in MIL-DTL-83133. Its requirements are listed in NATO STANAG/AFLP 3747.
- b. JP-5: High flash point additized aviation turbine fuel meeting the requirements in MIL-DTL-5624.
- c. JP-8: Additized aviation turbine fuel meeting the requirements in MIL-DTL-83133.
- d. Jet A-1: Aviation turbine fuel meeting the requirements in Defence Standard 91-091.
- e. TS-1: Aviation turbine fuel grade in GOST 10227.
- f. JPTS: Thermally stable aviation turbine fuel meeting the requirements in MIL-DTL-25524.

6.5.1 Seamless construction. Construction by any method that results in the absence of seams or discontinuities in the material.

6.6 Subject term (key word) listing.

Brake line
Elastomeric
Lube
Pneumatic systems
TSO-C53a Type A
TSO-C53a Type C

MIL-DTL-8794F
w/AMENDMENT 5

6.7 Amendment notations. The margins of this specification are marked with vertical lines to indicate modifications generated by this amendment. This was done as a convenience only and the Government assumes no liability whatsoever for any inaccuracies in these notations. Bidders and contractors are cautioned to evaluate the requirements of this document based on the entire content irrespective of the marginal notations.

CONCLUDING MATERIAL

Custodians:

Army - AV
Navy - AS
Air Force - 71
DLA - CC

Preparing activity:

DLA - CC

(Project 4720-2020-019)

Review activities:

Army - AT, MI
Navy - MC, SA
Air Force - 11

NOTE: The activities listed above were interested in this document as of the date of this document. Since organizations and responsibilities can change, you should verify the currency of the information above using the ASSIST Online database at <https://assist.dla.mil>.