

NOT MEASUREMENT
SENSITIVE

MIL-DTL-87929D
20 April 2012

SUPERSEDING
MIL-DTL-87929C
1 February 2000

DETAIL SPECIFICATION TECHNICAL MANUALS, OPERATION AND MAINTENANCE INSTRUCTIONS IN WORK PACKAGE FORMAT (FOR USAF EQUIPMENT)



Comments, suggestions, or questions on this document should be addressed to: ESC/HGGI, 4170 Hebble Creek Road, Bldg. 280, Door 15, Area A, Wright-Patterson AFB, OH 45433-5653 or emailed to: SGMLsupport@wpafb.af.mil. Since contact information can change, the currency of this address information should be verified using the ASSIST Online database at <https://assist.daps.dla.mil/>.

AMSC N/A

FSC TMSS

DISTRIBUTION STATEMENT A. Approved for public release; distribution is unlimited.

MIL-DTL-87929D**NOTE**

This specification is approved for use by the Department of the Air Force and is available for use by all Departments and Agencies of the Department of Defense.

1 SCOPE

1.1 Scope. This detail specification covers the requirements for preparation of equipment Operation and Maintenance (O&M) Technical Manuals (TM) in Work Package (WP) and Subordinate Work Package (SWP) formats. Manuals, using the WP and SWP concept described within this specification, are intended for use at Intermediate and Depot levels on all equipment and at Organizational level for equipment not using the MIL-DTL-83495 maintenance manual concept. This specification provides for Standard Generalized Markup Language (SGML) Document Type Definitions (DTD) usage (see appendices [A.1](#) through [L](#)) required for electronic data delivery. All appendices are intended for compliance when required. The type(s) of manual(s) to be prepared, as specified by the acquiring activity, are as follows:

- a. Maintenance Manuals.
 1. Intermediate Maintenance Manuals.
 2. Depot Maintenance Manuals.
 3. Combined Maintenance Manuals.
 4. On-Condition Maintenance Instruction Manuals (engines only).
 5. Manual Set.
 6. Accessories.
- b. Operation and Maintenance Instruction Manuals.
- c. Special Technical Manuals.
- d. Checklists.

2 APPLICABLE DOCUMENTS

2.1 General. The documents listed in this section are specified in sections [3](#), [4](#), or [5](#) of this specification. This section does not include documents cited in other sections of this specification or recommended for additional information or as examples. While every effort has been made to ensure the completeness of this list, document users are cautioned that they must meet all specified requirements of documents cited in sections [3](#), [4](#), or [5](#) of this specification, whether or not they are listed.

2.2 Government documents.

2.2.1 Specifications, standards, and handbooks. The following specifications, standards, and handbooks form a part of this document to the extent specified herein. Unless otherwise specified, the issues of these documents are those cited in the solicitation or contract.

MILITARY SPECIFICATION

MIL-PRF-5096	Manuals, Technical: Inspection and Maintenance Requirements; Acceptance and Functional Check Flight Procedures and Checklists; Inspection Work Cards; and Checklists; Preparation of
MIL-PRF-38807	Manuals, Technical: Illustrated Parts Breakdown, Preparation of

MILITARY STANDARDS

MIL-STD-681	Identification Coding and Application of Hookup and Lead Wire
MIL-STD-38784	Technical Manuals: General Style and Format Requirements

(Copies of these documents are available online at <https://assist.daps.dla.mil/quicksearch> or from the Standardization Documents Order Desk, 700 Robbins Avenue, Building 4D, Philadelphia, PA 19111-5094.)

MIL-DTL-87929D

2.2.2 Other Government documents, drawings, and publications. Other Government documents, drawings, and publications. The following other Government documents, drawings, and publications form a part of this document to the extent specified herein. Unless otherwise specified, the issues are those cited in the solicitation.

PUBLICATIONS

AIR FORCE TECHNICAL MANUALS

TO 00-25-203

Contamination Control of Aerospace Facilities, US Air Force

TO 00-85-series

Preservation, Packaging and Packing External Aircraft Fuel Tanks/Cells

(Copies of documents required by contractors in connection with specific procurement functions should be obtained from the acquiring activity or as directed by the contracting officer.)

2.3 Order of precedence. In case of conflict between the text of this document and the references cited herein, the text of this document takes precedence. Nothing in this document, however, supersedes applicable laws and regulations unless a specific exemption has been obtained.

3 REQUIREMENTS.

3.1 General requirements. The general manner of preparation shall be in accordance with MIL-STD-38784 unless otherwise specified herein. The acquiring activity shall determine if the manuals are to be prepared in single or double column format (see 6.2c.).

3.1.1 Electronic presentation requirements. Electronic presentation requirements prescribed herein shall apply only to the development of Type 1 linear data for electronic viewers. For development of Portable Document Format (PDF) data, print presentation requirements herein shall apply, as applicable.

3.1.2 Abbreviations. The requirements of MIL-STD-38784 are applicable.

3.1.3 Size of manuals. Print presentation: Work package manuals shall be prepared in the 8 1/2 by 11-inch sizes only.

3.2 Categories of manuals.

3.2.1 Maintenance manuals. Maintenance manuals shall contain detailed procedures such as disassembly, cleaning, inspection, repair, rework, major overhaul, assembly, test, etc. Procedures shall be provided for all parts, subassemblies and assemblies coded (Source, Maintenance, and Recoverability [SMR] code) for repair. Specific data shall be provided to adequately describe acceptable repairs, including specifications for materials to make repairs. The manuals may also include an illustrated parts breakdown. The manuals shall include only the level of maintenance authorized by the users maintenance concept and authorized support equipment. Depot maintenance manuals shall cover complete major repair and overhaul procedures. The type(s) of manuals to be prepared shall be specified by the acquiring activity (see 6.2c.).

3.2.1.1 Intermediate maintenance manual. The intermediate maintenance manual shall contain repair instructions required for maintenance and repair of removed equipment at base level activities.

3.2.1.2 Organizational maintenance manual. Organizational maintenance on installed equipment will normally be covered in the weapon system (e.g., aircraft, missile, communications station, etc.) maintenance manual. When specified, organizational manuals shall be produced in accordance with this specification.

3.2.1.3 Depot maintenance manual. The depot maintenance manual shall contain instructions required for depot repair and overhaul of equipment, modules, and component parts. The acquiring activity shall specify (see 6.2.c.3.) whether the manual shall be developed to support horizontal or vertical disassembly and assembly maintenance concept (engines and missiles only).

3.2.1.4 Combined maintenance manual. When specified (see 6.2.c.4.) Intermediate and Depot maintenance manuals may be combined, depending on size and complexity of the equipment. Instructions that are beyond intermediate maintenance capability, due to authorized support equipment, tools, or skills, shall be identified as depot only. If duplication of material is required, it shall be in accordance with MIL-STD-38784 and may only be duplicated to preserve WP/SWP integrity or clarity.

MIL-DTL-87929D

3.2.1.5 On-condition maintenance instruction manual (engines only). When specified (see 6.2.c.5.) on-condition maintenance instructions shall be provided for conditional or unscheduled maintenance required for repair and/or replacement of parts, components, modules, assemblies, and subassemblies necessary to restore equipment to a serviceable condition. This manual shall contain those procedures developed to gain quick access to areas requiring maintenance rather than following the total disassembly and assembly process. A maintenance sequence diagram of maintenance requirements shall be provided. This diagram shall provide a step-by-step manner in which the equipment will be disassembled and reassembled for repair and/or preventive maintenance. It shall graphically represent the required removal/installation sequence for each equipment component/assembly. Specific test procedures and limits shall be provided.

3.2.1.6 Manual set. When specified by the acquiring activity (see 6.2.c.6.) based on the number of assemblies or complexity of the equipment, the maintenance manual may be prepared as separate manuals for each major assembly.

3.2.1.7 Accessories. When specified by the acquiring activity (see 6.2.c.7.) manuals shall be prepared for major accessories. Suitable reference shall be made in the maintenance manual to applicable accessory technical manual identification numbers. This shall be done in tabular form, cross referencing part number and nomenclature to technical manual identification number.

3.2.2 Operation and maintenance instruction manual. Operation and maintenance instruction manual(s) shall contain, as applicable, but not be limited to, the following: General system information, receiving and handling, servicing, operation, inspection, maintenance, preparation for shipment and storage, limits, difference data, and illustrated parts breakdown (see 3.5).

3.2.3 Special technical manuals. Certain equipment requiring operation and maintenance instructions that have unique characteristics, unusual support requirements, and other uncommon considerations shall require additional specific information. This peculiar or unique information shall be included in standard manuals and associated technical WPs as described in Appendices B thru L (see 3.6). Examples of this type of operation and maintenance procedures are Aircraft Engine Testing and Trending Procedures, Parachute Packing Procedures, Special Requirements For Storage and Maintenance Procedures; AUR Munitions and Associated Support Equipment, Conventional Components and Chemical Munitions/Biological Research (CMBR) Agents, and ATE Operator Test Procedures Manual. If conflicts exist between the guidance of the standard WPs and the guidance contained in the special technical manuals appendices, the special technical manual appendix guidance shall take precedence.

3.2.4 Checklists. When specified (see 6.2.j.) checklists shall be prepared in accordance with MIL-PRF-5096. Procedures from individual WPs shall form the basis for the checklist tasks.

3.3 General WP/SWP requirements.

3.3.1 WP description. Each WP prepared shall be an independent, task/process oriented unit, using a minimum amount of references. Only essential information shall be provided. Text shall be factual, concise, comprehensive and readily understandable to personnel with a minimum of training and experience in the area where the data will be used. Technical phraseology or symbols that require specialized knowledge shall not be used unless no other word or phrase will convey the intended meaning.

3.3.2 WP coverage. Work packages may cover such subjects as alphabetical index (for a manual), foreword (to a manual), theory of operation, operating instructions, troubleshooting or fault isolation, alignment, disassembly, assembly, cleaning, inspection, and repair. Each WP shall contain the minimum amount of information required to complete the coverage of the functional task.

Print presentation: WPs shall always begin on a right-hand page.

3.3.3 SWP description. A WP may be subdivided into SWPs. This division shall be used when one division by WP is not sufficient to maintain a logical sequence of data, for clarity, or to isolate specific maintenance level requirements of a combined manual.

Print presentation: SWPs shall always begin on a right-hand page.

3.3.4 Numbering of WP/SWPs. WP/SWP numbers shall be in Arabic numerals with a seven digit field allowed, beginning with the number 001 00. The first three digits shall identify the WP number. The last

MIL-DTL-87929D

two digits of the WP number shall identify the SWPs. SWPs shall be numbered 01 through 99, as required. There shall be two spaces between the WP number and SWP number, e.g., SWP 007 05. There shall be one space between "WP" or "SWP" and the WP number, e.g., SWP 007. The Alphabetical Index WP shall always be the first WP in the manual and assigned the number 001 00. Foreword WP shall always be the second WP in the manual and assigned the number 002 00. Master List of Special Tools, Test Equipment, and Consumables shall always be the third WP in the manual and assigned the number 003 00. The fourth and subsequent WPs in the manual shall be numbered 004 00 through 997 00 as required.

Print presentation: The WP/SWP number shall be immediately below the TM identification number.

Electronic presentation: The WP/SWP number shall be placed in an area to make it persistently visible.

3.3.4.1 Numbering of added WP/SWPs. Addition of new WP/SWPs within the manual (that cannot be logically added at the end of the sequence) shall be avoided whenever possible. When such additions are required, numbering of the added WP/SWPs shall be as shown in the following examples:

- a. A new WP added between existing WP 027 00 and WP 028 00 would be numbered WP 27A 00.
- b. A new SWP added between existing SWP 036 12 and 036 13 would be numbered 036 12A with only one space between 036 and 12A.
- c. A new SWP added between existing SWP 017A 14 and 017A 15 of a previously added WP would be numbered 017A14A. This method of numbering utilizes the two (2) blank spaces that normally separates the three (3) digit WP number from the two (2) digit SWP number, yet sustains the seven (7) digit field allowed for the overall WP/SWP number.

3.3.5 Numbering of figures, tables, and pages. Figures, tables, shall each be numbered consecutively, within each WP or SWP, using Arabic numerals.

Print presentation: Pages shall be numbered consecutively, within each WP or SWP, using Arabic numerals.

3.3.6 Numbering of added material. Numbering of added material within a WP/SWP shall be in accordance with the requirements of MIL-STD-38784.

3.3.7 Assignment of WP/SWP titles. Titles shall be assigned with full consideration of the effect they may have on easy, rapid access to data. The name of the object or equipment shall precede the modifier. A title such as Compressor Inlet Variable Vane Control and Cylinder may cause the reader unnecessary time in attempting to retrieve the information needed. A more effective title would be Control and Cylinder, Variable Vane, Compressor Inlet.

3.3.8 Text content. Collectively, the WP/SWPs shall provide all essential information required to operate, maintain, and support the equipment for which these manuals are prepared. Text shall be complemented by appropriate illustrations to the extent necessary for complete coverage and understanding. Emphasis shall be placed on the specific steps of the maintenance procedures to be followed, the results which may be expected or desired, and the corrective measures required when such results are not obtained. Procedures requiring a team of specialists for accomplishment of maintenance tasks shall have the tasks of these individuals designated separately in sequence of required accomplishment. Use of warnings, cautions, and notes shall be in accordance with MIL-STD-38784.

3.3.8.1 Paragraphs. Paragraphs shall be consecutively numbered in accordance with MIL-STD-38784 except chapter number prefix shall be omitted. Paragraph titling shall be in accordance with MIL-STD-38784 except only primary sideheads must be titled.

3.3.8.2 Nomenclature. Nomenclature shall be in accordance with of MIL-STD-38784. Consistency shall be maintained between nomenclature in text, callouts on illustrations on the first occurrence of an equipment item, and the nomenclature in Illustrated Parts Breakdown (IPB) manuals. Nomenclature corresponding to that appearing on the equipment in decals, engraved legends, nameplates, or other markings shall be repeated verbatim on the first occurrence. On subsequent occasions, if there is no other name with which it might be confused, the nomenclature may be shortened. For example, the external main power switch may be called the power switch if no other switch has been mentioned or illustrated on the same illustration. Simple identifying nomenclature may be provided for attaching parts in both pictorial callouts and text, such as lower attaching bolts. All hardware items involved in a task shall be specifically mentioned. Terminology

MIL-DTL-87929D

that conveys the purpose, function or nature of an item that is irrelevant to the task requirement shall not be used. For example, the unified fuel control cable quadrant need not be called such in an instruction to insert a rig pin. The presence of an illustration showing the location of the unit enables the instruction to be written simply: "Insert rig pin in quadrant," or "Insert rig pin." Modifiers are required only when one or more items of the same object nomenclature are acted upon in the same task.

3.3.8.3 References. The requirements of MIL-STD-38784 and those below apply:

- a. Information contained in the foreword WP shall not be duplicated in other maintenance WPs or SWPs. When required, theory shall be referenced under "Referenced Material Required" (see 3.4.3.4.1). Normally, theory shall not be referenced in text.
- b. Replacement or repair instructions on testing and troubleshooting fault logic diagrams, or in fault logic text shall not be listed as WP/SWP reference material. Rather, this information shall be referenced in one of the following methods:
 1. On the fault logic diagram.
 2. In the fault logic text.
 3. In tabular form in the WP or SWP.
- c. References to manuals prepared in WP format shall be by publication number and WP number. For example; "Refer to TO 2J-XXX-X WP 012 00," or "Perform operational checkout of the Rear Compressor Variable Vanes (TO 2J-XXX-X, WP 231 00)."
- d. References within the same manual shall be by WP or SWP number: For example, "Remove main oil pump (WP 223 00)," or "Install oil pressure transmitter (SWP 223 07)."
- e. Reference material shall be included under "Reference Material Required" (see 3.4.3.4.1) within the following guidelines:
 1. Publications (other than technical manuals prepared in WP format) required to complete the task, or support discussion presented, shall be listed by title and publication number.
 2. WPs and SWPs required to complete the task or support discussion shall be listed by title, publication number, WP/SWP title and WP/SWP number. When two or more WP/SWPs are referenced in the same manual, repetition of the manual title and publication number shall not be required if they are listed consecutively.
- f. WPs shall be complete within themselves without excessive cross-reference to one another. Self-contained, task-oriented, work packages with minimum references are preferred. Material may be extracted from other publications, but only the specific information required by the user to perform a specific function shall be included.
- g. Reference to equipment, its parts or components, shall be by type designation, standard nomenclature, reference designation, or figure and index number as applicable. The principle noun in names of items shall be consistent throughout the manual. Reference to part numbers, after the first callout, shall be held to a minimum.
- h. Electrical and electronic reference designations shall be in accordance with MIL-STD-38784.
- i. Reference to chassis wiring color shall be in accordance with MIL-STD-681. Chassis wiring in equipment which does not conform to MIL-STD-681 shall be explained in the manual.

3.3.9 Illustrations. Illustrations and foldouts shall be in accordance with MIL-STD-38784.

3.3.9.1 Line art. All illustrations shall be line art, utilizing illustration techniques such as two dimensional, cutaway, or exploded views.

3.3.9.2 Procedural illustrations. Step-by-step sequential illustrations shall be included as required for clarity depicting special tool usage and mechanical operations. Procedural illustrations shall depict the actual sequence of significant events to perform a task. It is not necessary to illustrate each step of a procedure such as removal of screws with an ordinary screwdriver, or lifting of a cover after the

MIL-DTL-87929D

screws have been removed. The illustrations shall include brief instructions as required, tool numbers, dimensions and other pertinent information.

3.3.9.3 Exploded views. Exploded views of the equipment shall be in accordance with MIL-STD-38784.

3.3.9.4 Repair illustrations. Pictorial displays shall depict all information necessary to support a repair procedure.

3.3.9.5 Inspection illustrations. Illustrations shall support inspection limits by clearly showing all points of limits. Access and inspection openings shall be indicated by index number and a tabulation of the equipment or parts for which access is provided. Illustrations shall not show limit values but shall show reference callouts with leaders to the point of clearance.

3.3.9.6 Illustration keys. Print presentation: Legends or tables applicable to partial page illustrations shall, whenever possible, appear on the same page. If adequate room is not available, or for a full page illustration, the information shall appear on a facing or following page. If the legend or table, exceeds the allowable space, it may be continued on a second page.

Electronic presentation: Legends or tables applicable to partial screen view illustrations shall, whenever possible, appear in the same view. If adequate room is not available, or for a full view illustration, the information shall appear in a scrollable view. If the legend or table, exceeds the allowable space, it shall also be scrollable.

3.3.10 Diagrams. The manual shall include diagrams and associated data necessary for maintenance personnel to:

- a. Understand the makeup and function of each component, power, control, and signal circuit, and of each mechanical system.
- b. Trace each circuit and mechanical system.
- c. Accomplish general and specific troubleshooting on inoperative or malfunctioning circuits or mechanical systems.

Print presentation: Foldouts shall be in accordance with MIL-STD-38784.

3.3.10.1 Explanatory text. The foreword WP shall contain an explanation of the diagrams used in the manual as to their content and proper use. This shall include the working relationship to material in other WP/SWPs, how to locate a particular diagram, an explanation of the wiring identification system used on the diagrams, when applicable, and any other information considered essential for proper understanding and use.

3.3.10.2 Symbols. Symbols shall be in accordance with MIL-STD-38784.

3.3.10.3 Schematic diagrams.

3.3.10.3.1 Schematic diagram general requirements. Where the equipment's nature, relative complexity, and number of components make it feasible, a single schematic diagram shall be prepared to cover all signal circuits, power circuits, and control circuits. When a single diagram is infeasible, a separate diagram shall be prepared for each item of equipment. Any circuits left in "midair" and picked up on other diagrams and which terminate with a plug, terminal strip, or jack, shall show a composite plug grouping. Each lead shall be extended through the plug, terminal strip, or jack, and labeled to indicate the necessary designator of the first connection within the other component, or other significant point of termination.

3.3.10.3.1.1 Interconnections. When the equipment obtains information from, or supplies information to other items of equipment of a system, diagrams shall be provided showing all required interconnections, unless this information is not contained in a system manual. If provided by a system manual, reference shall be made to that manual.

3.3.10.3.1.2 Circuits. Power circuits, control circuits, and signal flow within a particular circuit(s) or functional loop(s) shall be identified.

3.3.10.3.2 Schematic diagrams for equipment. A schematic diagram of an item of equipment shall show the following:

- a. Subassemblies shall be indicated by a series of broken lines.

MIL-DTL-87929D

- b. For each detail part, identification shall be by reference designations.
 - c. For each detail part, the principal electrical characteristics expressed in actual values (ohms, microfarads, microhenrys, etc.) shall be tabulated next to the diagram and indexed by reference designation to applicable points on the diagram when sufficient space is not available on the diagram itself. Values normally shall be expressed as numbers, omitting the unit of measurement (such as ohms). However, a general note shall state which units are used.
 - d. Wave shapes, duration, and amplitude of voltages at designated test points throughout the circuit and at interconnecting points within the equipment or systems, under normal test conditions and other specified conditions, shall be indicated on the schematic diagram of the component.
- 3.3.10.3.3 Overall schematic diagrams. If separate component diagrams are not provided, the overall equipment schematic shall show the information identified in 3.3.10.3.2. In addition, diagrams shall show inter-equipment circuits with the connections and terminals properly numbered. Items of equipment shall be indicated by a series of broken lines.
- 3.3.10.3.4 Power and control schematics. Separate schematic diagrams to show the power and control circuits, when it is infeasible to show such information on the overall schematic diagram, shall be prepared as follows: each power circuit and each control circuit with its relationship to the signal circuits using a combination of blocks, schematics, or pictorial diagrams; tolerances of power distribution associated with each power and control circuit.
- 3.3.10.3.5 Module schematic diagrams. Schematic diagrams of electronic modules, when shown separately, shall be arranged to indicate signal flow progressing from left to right. Where possible, an equivalent block/logic diagram of the module circuitry shall be placed on the schematic to aid in interpreting the schematic.
- 3.3.10.4 Logic diagrams. When feasible, overall operation of the equipment shall be shown by conventional logic diagrams. Current equipment utilizing solid state and integrated circuit devices is understood and troubleshooting is accomplished by means of logic diagrams rather than detailed schematics.
- 3.3.10.5 Waveform diagrams. Waveform diagrams shall be provided, if required, in support of maintenance tasks and the information is not provided on functional or schematic diagrams. These diagrams shall show the waveforms and nominal values, as seen in an oscilloscope of a type listed in WP 003 of the manual, at designated points for normally functioning equipment or systems. Operating conditions and switch positions shall be noted at the time of each indication.
- 3.3.10.6 Terminal voltage diagrams. Voltages to ground, or identified points for all sockets and terminal points of individual circuits shall be shown on terminal voltage diagrams. These diagrams shall provide measurements between various subassemblies, assemblies, and detail parts of a component or equipment of a system. Voltages between terminals shall be shown if significant. All pin numbers shall be shown. The ohm-per-volt rating of the voltmeter and its voltage scale shall be indicated. The type of voltage (AC or DC) and critical voltages and frequencies shall be stated, showing allowable tolerances. The power supply, if any, and all control settings shall be noted.
- 3.3.10.7 Terminal resistance diagrams. Resistance to ground, or to other identified points for all socket terminals and terminal points of individual circuits shall be shown on terminal resistance diagrams. Preparation shall be essentially the same as for terminal voltage diagrams.
- 3.3.10.8 Combination diagrams. Combinations of the information required by 3.3.10.3 through 3.3.10.7 shall be shown on a single diagram, where feasible.
- 3.3.10.9 Interconnection cable diagrams. These diagrams shall show the cabling or connections for the system, equipment, or component. Interconnections between components or equipment shall be indicated by either a diagram or a table. Where applicable, a complete internal wiring diagram of each junction box, indicating the relationship to the external wiring circuits, shall be provided.
- 3.3.11 Test point identification. Test point identification shall be incorporated on schematic wiring diagrams, tables, charts, and illustrations. Test point identification will not be required for equipment with self-test capability, equipment designed to be tested by an automatic checkout system, and equipment designed with

MIL-DTL-87929D

critical test points accessible at front panel connectors. Where the design of the equipment includes built-in test capability, tests performed using this capability shall be identified but not outlined in detail. Any function requiring the participation of maintenance personnel, or interpretation of test results, shall be included in detail. Instructions required to determine the operability of the design built-in test circuits and components, fault isolation and repair instructions, shall be included. Symbols shall be as marked on the equipment, or as they appear on applicable engineering drawings. Voltages, waveforms, etc., should be placed adjacent to the test point and if required may be in tabular form. Indiscriminate use of test points shall be avoided; for example, test point identification shall normally be restricted to signal tracing test points and voltage and continuity check points. The following test point identification system shall be used:

3.3.11.1 Major test points. A star-enclosed Arabic numeral, ☆, is used to identify and designate the test points used in checking the overall functions of, and localizing trouble to individual components, or groups of components. Major test points are identified on schematic wiring diagrams, tables, charts, and illustrations by use of the Arabic numerals 1, 2, 3, etc., enclosed in a star; but shall be referred to in the text as test point 1, test point 2, etc. Typical examples of major test points are:

- a. The input terminals for the supply source voltage.
- b. The high voltage output terminals of the equipment's power system.
- c. The signal input terminals of the equipment.
- d. The signal output terminals of the equipment.
- e. The major points of power or voltage distribution within the equipment.

3.3.11.2 Secondary test points. An encircled capital letter, (A), is used to identify and designate the test points used in isolating causes of subnormal performance within a specific assembly or subassembly of the equipment. Secondary test points are identified on schematic wiring diagrams, tables, charts, diagrams, and illustrations by use of capital letters, A, B, C through Z; AA, AB through AZ; BA, BB through BZ, etc., enclosed in a circle; but shall be referred to in the text as test point A, test point B, etc. Typical examples of secondary test points are:

- a. Circuit supply voltage terminals.
- b. Signal output points used in checking the gain of a stage or group of stages.

3.3.11.3 Minor test points. An encircled capital letter and Arabic numeral, (A1), is used to identify and designate the test points used in isolating causes of abnormal indications within a specific circuit of the equipment. Minor test points are identified on schematic wiring diagrams, tables, charts and illustrations by use of a capital letter and Arabic numeral, A1, A2, etc., enclosed in a circle; but shall be referred to in the text as test point A1, test point A2, etc. Different letters shall be assigned to each component. Typical examples of minor test points to be so designated are:

- a. Specific voltage and resistance check points.
- b. All other points used in checking for trouble in a specific circuit.

3.3.11.4 Assignment of symbols. Test point identification symbols on the schematic wiring diagrams shall be assigned consecutively throughout the composite equipment. Once assigned, a symbol shall not be reassigned to another test point. An explanation of the use of test points shall appear in the Foreword WP of the manual.

3.4 Arrangement. Appendix A.1 provides information for obtaining the DTD for electronic delivery of the standard WP manual.

3.4.1 Manual arrangement. The technical manual(s) shall be arranged in the following order:

- a. Front Matter (see 3.4.1.1).
- b. Alphabetical Index (WP 001 00) (see 3.4.3.1).
- c. Foreword (WP 002 00) (see 3.4.3.2).
- d. Master lists of special tools, test equipment, and consumables (WP 003 00) (see 3.4.3.3).

MIL-DTL-87929D

- e. Technical procedures WP/SWPs (see 3.4.3.4).
- f. Illustrated Parts Breakdown (when applicable) (see 3.4.3.5).
- g. Difference data sheets (when applicable) (Last WP of manual) (see 3.4.3.6).

3.4.1.1 Front matter. The front matter of the manual, or first manual in a manual set, shall be as follows:

- a. Title page. Print presentation: In accordance with MIL-STD-38784.
Electronic presentation: In accordance with MIL-STD-38784.
- b. List of Effective Pages. Print presentation: Listing only the front matter pages for that manual. In accordance with MIL-STD-38784. The total manual page count statement shall read as follows: "THE TOTAL NUMBER OF PAGES IN THIS MANUAL IS ____."
- c. Verification Status Page (when applicable). Print presentation: In accordance with MIL-STD-38784.
Electronic presentation: In accordance with MIL-STD-38784.
- d. Numerical Index of Effective Work Packages (see 3.4.1.1.1).
- e. Safety Summary. In accordance with MIL-STD-38784.

3.4.1.1.1 Numerical Index of Effective Work Packages.

- a. The title "NUMERICAL INDEX OF EFFECTIVE WORK PACKAGES" shall be centered below the header.
- b. The following note shall be placed below the title: "Only those work packages and subordinate work packages assigned to this manual are listed in this index, therefore WP/SWP numbers may not be sequential."
- c. Print presentation: In Change 1 and subsequent changes to the manual, the following shall be added to the note required by subparagraph (b), above: "Insert Change No. _____, work packages and subordinate work packages, dated _____. Dispose of superseded work packages and subordinate work packages. If changed pages are issued to a work package or subordinate work package, insert the changed pages in the applicable work package or subordinate work package. The portion of the text affected in a change or revised WP or SWP is indicated by change bars in the outer margin of each column of text. Changes to illustrations and diagrams are indicated by pointing hands or shaded areas."
- d. The following column heads shall be placed below the applicable statements required by b. and c. above:

NUMERICAL INDEX OF EFFECTIVE WORK PACKAGES

WP/SWP No.	Change No.	Model Application	Title
------------	------------	-------------------	-------

- 1. The Model Application column shall be used only if more than one equipment model is covered by the manual.
- 2. A numerical listing of each WP/SWP assigned to the manual shall be placed below the applicable column heads. Deleted WPs and SWPs shall be accounted for by the entry "Deleted" and the applicable change number listed in the Change Number Column following the applicable WP/SWP number.
- 3. The title of each WP/SWP shall be included in the Title column.

3.4.2 Manual set arrangement. When a manual set is prepared, the primary manual of the set shall contain complete front matter as described in 3.4.1.1. All other manuals of the set shall contain the following abbreviated front matter and applicable technical procedure WP/SWPs.

- a. Title page. Print presentation: In accordance with MIL-STD-38784.
Electronic presentation: In accordance with MIL-STD-38784.

MIL-DTL-87929D

- b. List of Effective Pages. Print presentation: Listing only the front matter pages for that manual. In accordance with MIL-STD-38784.
- c. Verification Status Page (when applicable). In accordance with MIL-STD-38784.
- d. Numerical Index of Effective Work Packages. (For that manual only.)

3.4.3 WP/SWP arrangement.

3.4.3.1 Alphabetical index WP. The alphabetical index shall always be the first WP in the manual or of the first manual of a set. The alphabetical index shall be prepared in accordance with the following:

- a. The first page/view of the index shall be the title page/view (see Figure 1) consisting of:
 - 1. Technical Manual Identification Number. As assigned to overall manual.
 - 2. WP/SWP Number. As assigned to individual WP/SWP.
 - 3. Title. Shall include, "WORK PACKAGE" or "SUBORDINATE WORK PACKAGE" as applicable; Type of WP/SWP; Procedures covered.
 - 4. Effectivity.
 - 5. List of Effective WP pages.
- b. Include level of maintenance codes (intermediate, depot) for combined manuals (see 3.2.1.4).
- c. List all WP/SWPs subject, in alphabetical order by subject, and WP/SWP number, (see sample headings). (Also list applicable TO number when manual set is used.) The listing may begin on the bottom of the title page if this will not crowd the information.

Subject	WP/SWP	Subject	WP/SWP
---------	--------	---------	--------

3.4.3.2 Foreword WP. The Foreword WP shall always be the second WP of the manual, or of the primary manual of a manual set. The first page/view of the WP shall be the title page/view consisting of the requirements found in 3.4.3.1a. The Foreword WP shall contain, but not be limited to, the following:

- a. Table of contents. In accordance with MIL-STD-38784.
- b. List of illustrations. In accordance with MIL-STD-38784.
- c. List of tables. In accordance with MIL-STD-38784.
- d. Foreword/Preface/Introduction requirements of MIL-STD-38784.
- e. Purpose and scope of the maintenance manual or set.
- f. Structure of the manual or set.
- g. Type of coverage contained in each manual (for manual set).
- h. Scheme of indexing, e.g., the methodology used to breakout the manuals/WPs/SWPs.
- i. Procedures for locating specific information.
- j. Procedures and other relevant information that may increase the usability of the manual set.

3.4.3.2.1 General information. General information to be used by maintenance personnel to further their understanding of the equipment, assemblies/modules, and related systems shall be provided. A brief description shall reflect the equipment's purpose and main features. The integration of all components and accessories into an operational system shall be explained. Appropriate illustrations or exploded views shall be provided. Information such as cylinder numbering system, compressor stages, combustion chamber arrangement, etc., shall be depicted. Major assemblies, sections, modules, and accessories, shall be depicted and appropriately described, as necessary, to facilitate understanding. If the manual covers more than one model, significant differences shall be explained. A table of leading particulars listing the following type information shall be included:

- a. Fuse complement by component: Quantity, type, rating.
- b. Power requirements: Voltage, type, frequency, tolerance.

MIL-DTL-87929D

- c. Location and function of operating and adjustment controls used in normal operation.
- d. Other significant features: For example; length of stroke, operating pressure, displacement, duty cycle, inlet and outlet connection sizes, and direction of rotation.

3.4.3.2.2 Maintenance concept. The maintenance concept shall contain explanations of "Operation and Maintenance", "Intermediate/Depot Maintenance", "On-Condition Maintenance", horizontal and/or vertical maintenance (e.g., engines), and other relevant information. When applicable the narrative shall include definitions of unusual terms and abbreviations.

3.4.3.2.3 Environmental control. When applicable, environmental control (clean room) information required for maintenance or overhaul of equipment shall be specified.

3.4.3.2.4 Warranty provisions. When applicable, equipment/hardware warranty provisions shall be included. Only those provisions that affect or limit equipment operation, maintenance, or repair procedures shall be stated. For example, if a unit contains a power supply which is under warranty, a statement similar to the following would be used: "Power supply PS2 is a warranted item. During the warranty period, maintenance of the power supply is limited to removal and replacement of the input filters or the complete power supply." Inclusion of warranty provisions in no way alleviates the requirement for repair procedures which will be used after expiration of the warranty.

3.4.3.3 Master list of special tools, test equipment, and consumables WP. This WP shall always be the third WP of the manual, or of the primary manual of a manual set. The first page of the WP shall be the title page/view consisting of requirements in 3.4.3.1a. This WP shall list all special tools, test equipment, and consumables required for the work described within the manual or manual set. Such items shall be selected from the list of tools and test equipment approved by the Government by means of Support Equipment (SE) listings, provisioning conferences, Engineering Change Proposals (ECP), and procurement documents. Standard types of tools, such as screwdrivers and pliers shall not be listed. Standard types of test equipment, such as voltmeters and tube testers shall be listed. When a contractor cannot obtain an approved list, a manual shall show the contractor's recommended special tools and test equipment. However, these recommendations shall be changed promptly to conform to the official Government list as soon as such information is provided to the contractor.

3.4.3.3.1 Master list of special tools. The list of special tools shall be arranged in the following format.

Master List of Special Tools

Part No./Specification No./NSN.	CAGE Code	Figure/Index No.	Nomenclature	Use
---------------------------------	-----------	------------------	--------------	-----

- a. Part (tool) Number. Tools shall be listed in alphanumeric sequence by part (tool) number, specification number, or national stock number.
- b. CAGE Code. Contractor and Government Entity (CAGE) code or manufacturers name and address if code is not available.
- c. Figure and Index Number. The figure and index numbers that appear in other WPs, or this WP, of the manual, shall be shown.
- d. Nomenclature. Nomenclature shall be in accordance with the requirements of MIL-STD-38784.
- e. Use. The purpose of each tool shall be stated. If the use is described in any part of the manual, reference to the applicable WP will suffice.

3.4.3.3.2 Master list of test equipment. The list of test equipment shall be arranged in the following format:

Master List of Test Equipment

Part No./Specification No./NSN	CAGE Code	Figure & Index No.	Nomenclature	Use
--------------------------------	-----------	--------------------	--------------	-----

MIL-DTL-87929D

- a. Part No./Specification No./National Stock Number (NSN). Test equipment shall be listed in alphanumeric (AN) sequence by part number, using the AN type designation, if assigned. If no part number is listed, either the specification number or NSN may be listed. If an alternate item of test equipment can be used, its AN type designation, if assigned, or the commercial or manufacturer's designation shall be listed immediately following the item for which it is an alternate, and be identified as an alternate in the use column.
- b. CAGE Code. Contractor and Government Entity (CAGE) code or manufacturers name and address if code is not available.
- c. Figure and Index Number. The figure and index numbers that appear in other WPs, or this WP, of the manual, shall be shown.
- d. Nomenclature. Nomenclature shall be in accordance with the requirements of MIL-STD-38784.
- e. Use. The purpose of each item of test equipment shall be stated. If the use is described in any part of the manual, reference to the applicable WP will suffice.

3.4.3.3.3 Master list of consumables. Consumable materials and expendable items shall be listed. All chemicals shall be grouped separately at the beginning of the list. The list shall be in tabular form, in alphabetical order by nomenclature, as follows:

Master List of Expendable Items and Consumable Materials

Nomenclature	Specification/Part No./NSN	CAGE Code	Use	Reference
--------------	-------------------------------	-----------	-----	-----------

- a. Nomenclature. Nomenclature in accordance with MIL-STD-38784.
- b. Specification/Part Number/NSN. The military, Government, or commercial specification number, part number, or NSN shall be shown.
- c. CAGE Code. (If part number is shown) CAGE Code, or manufacturer's name and address if code has not been assigned.
- d. Use. The use of the item, e.g., cleaning electrical contacts, paint touch-up, conformal coating, etc.
- e. Reference. The WP/SWP and paragraph(s) where the item is used.

3.4.3.3.4 Master list of containers. When specified (see 6.2d.) stocklisted reusable containers shall be listed in tabular format giving: nomenclature, figure no., container application and part no., number of units contained, dimensions, cube, weight loaded, and weight empty. Illustrations of the containers shall follow the table.

3.4.3.3.5 Repair of special tools and test equipment. When specified (see 6.2e.) instructions shall be provided for maintenance, inspection, repair, and test of special tools and test equipment unless coverage is contained in other manuals.

3.4.3.3.6 Local manufacture of tools/equipment. Instructions shall be included which explain how to order drawings for local manufacture tools/equipment. When specified (see 6.2f.) instructions for local manufacture of tools/equipment shall be included. These instructions shall include all data necessary for fabrication of the tool/equipment and shall include items such as parts required, procedures for fabrication and treating, special processes, etc.

3.4.3.4 Technical WP/SWP. The first page of each technical WP/SWP shall be the title page consisting of requirements in 3.4.3.1a. In addition, the following information, applicable only to that WP, shall be provided. The information shall continue on page 2, 3, etc., as required.

- a. Table of Contents. In accordance with MIL-STD-38784 except that only primary and first subordinate paragraphs shall be listed, regardless of inclusion of an index.
- b. List of Illustrations. In accordance with MIL-STD-38784.
- c. List of Tables. In accordance with MIL-STD-38784.

MIL-DTL-87929D

- d. Reference Material Required.
- e. Applicable Time Compliance Technical Orders (TCTO)s.
- f. Consumable Materials.
- g. Applicable Support Equipment.
- h. Illustrated Support Equipment.
- i. Table of Limits (when applicable).
- j. Foreword.
- k. Technical Procedures.

3.4.3.4.1 Reference material required. All documents referenced in the WP that are required to accomplish the task shall be listed in a tabular format by document number and title. If there is no reference material to list, then only the table heading shall be included and the words NONE shall be centered below the table title.

3.4.3.4.2 Applicable TCTOs. All TCTOs pertinent to the WP shall be listed. TCTOs that have been completed and rescinded shall be removed from the list at the next change to the WP. If there are no applicable TCTOs to list, then, only the table title shall be included and the words NONE shall be centered below the table title.

3.4.3.4.3 Consumable materials. Consumable materials, including expendable items, required within the WP shall be listed in a tabular format by nomenclature, specification/part number, and CAGE code. Chemicals shall be grouped separately at the beginning of the list. If there are no consumable materials to list, then, only the table title shall be included and the words NONE shall be centered below the table title.

3.4.3.4.4 Applicable support equipment. Applicable test equipment and special tools used in the WP shall be listed in a tabular format by part number, CAGE code, and nomenclature/type designation. If there is no applicable support equipment to list, then, only the table title shall be included and the words NONE shall be centered below the table title.

3.4.3.4.5 Illustrated support equipment. Test equipment and special tools not illustrated in use, within the WP, shall be illustrated. Standard tools and test equipment need not be illustrated. If there is no illustrated support equipment, then, only the heading shall be included and the words NONE shall be centered below the table title.

3.4.3.4.6 Table of limits. When applicable, each technical WP/SWP shall have a table(s) of limits including all clearances, backlashes, end-plays, spring pressure, etc., arranged in numerical sequence by reference number. The table of limits shall be supported by an illustration(s) to show clearly all points of limits. Illustrations shall not show limit values, but only reference numbers with leaders to the point of clearance. The table(s) shall be cross-referenced to the figure on which the reference number is located. The table shall be arranged as follows:

Dimensional Limits

Reference Number	Figure Number	Description	New Mini- mum/Maximum	Replacement Min- imum/Maximum
------------------	---------------	-------------	--------------------------	----------------------------------

3.4.3.4.7 Foreword. The foreword shall contain a brief description of the WP technical content.

3.4.3.4.8 Technical procedures. Technical procedures, for accomplishing the specific tasks required by the WP/SWP shall be included.

3.4.3.4.8.1 Warhead data. When applicable, procedures shall include any special instructions required for "high explosive" and "incendiary" type warheads.

3.4.3.4.8.2 Arming/de-arming procedures. When applicable, procedures for arming/de-arming of rocket motors and munitions shall be included.

3.4.3.4.8.3 Contingency procedures. When applicable, procedures shall contain instructions pertaining to special flight evaluation configurations, such as installation of a telemetry unit, and other procedures

MIL-DTL-87929D

which may be required. The WP shall also contain step-by-step procedures for each emergency condition that may occur during assembly, handling, servicing, or maintenance, and instructions for assembly and inspection at a forward base under heavy engagement.

3.4.3.5 Illustrated Parts Breakdown (IPB) WP. When specified (see 6.2g.) an IPB WP shall be prepared and shall be numbered 998 00. The first page of the WP shall be the title page consisting of requirements in 3.4.3.1a. Format and contents of the IPB WP shall be prepared in accordance with MIL-PRF-38807. The IPB may also be subdivided into SWPs. If the IPB uses SWP, only WP 998 00 shall contain the IPB front matter information.

3.4.3.6 Difference data WP. The difference data WP (when applicable) shall be numbered 999 00. The first page of the WP shall be the title page consisting of requirements in 3.4.3.1a. Use, format, and contents of difference data sheets shall be in accordance with requirements of MIL-STD-38784.

3.5 Technical WP/SWP development. The task development phase of technical manual preparation is critical because it will reflect the arrangement and alignment of the technical information. Based on maintenance requirements identified in the Supportability Analysis or approved maintenance plan, all tasks and support data shall reflect end item operation, inspection, fault isolation, and maintenance criteria at the appropriate level(s) of maintenance. Task analysis is the most appropriate method of establishing a matrix of task requirements and sequence of task actions. The depth and scope of task analysis depends on hardware sophistication and the magnitude of effort defined in the Supportability Analysis or approved maintenance plan. Therefore, this specification does not designate the specific technical WP/SWPs to use but instead designates the coverage of the information. WP/SWP breakdown shall correspond to the level and type of maintenance, tasks to be performed, etc. The WP/SWP breakdown can vary depending on equipment and maintenance complexities.

a. For example, a technical manual structure of typical technical WPs, with appropriate SWPs may be as follows:

1. Receiving and Handling WP
 - (a) Unpacking
 - (b) Receiving inspection
 - (c) Handling
 - (d) Assembly
 - (e) Checkout
2. Servicing WP
3. Operation WP
 - (a) Equipment fault isolation and correction
 - (b) Operator inspection
 - (c) Operator maintenance and servicing
4. Inspection WP
 - (a) Periodic and special inspection
 - (b) Visual inspection
 - (c) Sampling inspection
 - (d) Nondestructive inspection
 - (e) In-process inspection
5. Maintenance WPs
 - (a) Theory of operation
 - (b) Preparation for maintenance
 - (c) Fault isolation (troubleshooting)
 - (d) Disassembly

MIL-DTL-87929D

- (e) Cleaning
- (f) Corrosion prevention
- (g) Lubrication
- (h) Repair and replacement
- (i) Assembly
- (j) Servicing
- (k) Testing
- (l) Operational checkout
- (m) Follow-on maintenance
- (n) On-condition maintenance
- (o) Accessory maintenance
- (p) Scheduled maintenance
- (q) Programmed depot maintenance

6. Preparation for Shipment and Storage WP

- (a) Preservation and packing
- (b) Closing and sealing
- (c) Shipping and storage

7. Storage Inspection WP

b. The above WP/SWP arrangement is typical. Ideally, each WP/SWP in the manual shall be an independent, self-contained data unit. The writer may be required to group some tasks and divide others into WP/SWPs of suitable length. Actual WP/SWP arrangement, when appropriate:

1. May or may not include all subjects or categories of tasks.
2. WPs may be combined.
3. WPs may be broken out into two or more WPs.
4. WPs may be divided into SWPs.
5. SWPs may become WPs.
6. SWPs may be combined.
7. Additional SWPs may be developed.

c. Division or selection of coverage shall depend on the equipment covered, operational modes, complexity of maintenance actions, and maintenance level(s) covered. Regardless of the actual WP/SWP breakdown, logical sequence of task requirement occurrence shall be followed.

3.5.1 Receiving and handling. Receiving and handling procedures shall include instructions for unpacking, inspecting components and assemblies, and checkout of the equipment.

3.5.1.1 Unpacking. Unpacking procedures shall include instructions for unpacking of the equipment. When applicable, procedures shall also be included for retention and storage of serviceable packaging materials and shipping containers.

3.5.1.2 Receiving inspection. Receiving inspection shall contain procedures for inspection of inner package, identification of contents, correct marking, quantities, and possible damage to the equipment.

3.5.1.2.1 Inspection or damage terms. Inspection or damage criteria shall be preceded by a glossary of damage/inspection terms in the following format:

Term**Definition**

MIL-DTL-87929D

3.5.1.2.2 Inspection or damage requirements. Inspection or damage requirements shall be in the following format:

Item	Inspection (Inspect for the Following Defects)	Disposition
------	--	-------------

3.5.1.3 Handling. Procedures for proper handling of the equipment shall be furnished in the most logical order. Procedures shall include, but not be limited to, the following:

- a. Hoisting and moving procedures.
- b. Hoist points, push points, jack points.
- c. Positioning points.
- d. Load capacity of handling equipment, if critical.
- e. Mooring attachments and methods.
- f. Special or unique features or limitations that must be considered to preclude safety hazards to personnel or damage to equipment.

3.5.1.3.1 Propellant characteristics and safety precautions. Instructions shall contain all essential information concerning propellants that are used in the equipment. Physical characteristics of each propellant that is used shall be given, with emphasis on those characteristics which serve as identifying or distinguishing points. All necessary safety precautions that must be observed in handling and using propellants, covering, but not be limited to, such items as clothing, fire, contamination, containers, cleaning, and neutralizing, shall be given. Any danger signals shown by the propellant shall be explained fully and complete instructions given as to proper steps to take to avoid mishap. First aid action to be taken, in event of accident in handling propellants and oxidizers, shall be given.

3.5.1.3.2 Drop criteria. When applicable, component drop criteria shall be included in the following format:

Component Drop Criteria

Item	Packaged/Unpackaged	Drop Distance	Required Action
------	---------------------	---------------	-----------------

3.5.1.4 Assembly. Applicable instructions and illustrations for assembly of parts into major subassemblies, and final assembly of subassemblies to form a complete end item of equipment, including accessory units, shall be provided. Appropriate tests for operation of a subassembly prior to final assembly shall be provided, including applicable safety precautions to be observed. Extent of coverage for assembly, rigging, and adjustment shall depend upon the complexity of the equipment and required operations.

3.5.1.5 Checkout. Checkout, or functional checks, shall be provided for determining the operational suitability of the equipment, its components, and systems. Procedures shall be provided for individual components, assemblies, and overall equipment as required. All equipment components and sections, repaired or replaced shall be inspected before and after installation.

3.5.2 Servicing. Servicing information regarding capacities, pressures, and types of servicing fluids, as applicable, shall be provided. The specific location of each filler cap and servicing point shall be provided.

- a. Lubricating requirements shall be diagramed when necessary to ensure complete understanding (see Figure 2).
- b. Attachment of accessories and special wiring connections shall be illustrated.
- c. Leveling requirements, if applicable, including specific points where the leveling instrument shall be placed during this operation.
- d. Other procedures necessary to prepare the equipment for operation.

MIL-DTL-87929D

3.5.3 Operation. Operating procedures shall include principles and instructions for operating the equipment. Illustrations, wiring, and system diagrams, shall be used when necessary for a complete understanding of the subject. Complete operating instructions shall include, but not be limited to, the following:

- a. Safety precautions.
- b. Purpose and use of operating controls.
- c. Purpose and use of all indicating instruments.
- d. Equipment start-up procedures.
- e. Equipment normal operating procedures.
- f. Equipment emergency operating procedures.
- g. Accessory equipment operating procedures, including installed emergency equipment.
- h. Equipment shut down procedures, normal and emergency.

3.5.3.1 Equipment fault isolation and correction. The most common malfunctions which are likely to occur during equipment operation, a statement of probable cause(s), and a satisfactory remedy for each cause shall be included in tabular format as shown. This information shall be listed in probable occurrence sequence.

Fault Isolation and Corrective Action

Trouble	Probable Cause	Corrective Action
---------	----------------	-------------------

3.5.3.2 Operator inspection. All periodic inspections which are to be performed by the operator shall be included in a table, as shown in 3.5.4.1.2. Inspection periods shall be expressed in miles, hours of operation, or maximum periods of time that may elapse between inspections.

3.5.3.3 Operator maintenance and servicing. Operator maintenance and servicing instructions shall be provided. Components which require lubrication by the operator shall be identified and illustrated. The type and amount of lubricants and fluids shall be included. This information shall cover temperature ranges and other environmental conditions for which the equipment was designed. Types and specification numbers of the lubricants and fluids shall be included in the "List of Consumables."

3.5.4 Inspections. Procedures shall include the required inspection methods, equipment, and instructions for inspection of parts within the scope of the manual. Inspection instructions shall encompass failures, wear, damage, corrosion, leakage, aging, burning, malfunctioning, deformation, and deterioration that can be expected to occur during service or storage of the equipment. Allowable service limits and adequate standards for determining when parts should be repaired or replaced shall be included. Illustrations shall be used wherever necessary to augment inspection procedures. Connector pin location diagrams shall be provided when pin numbers cannot otherwise be located. Accordingly, definitions, illustrations, and limitations of descriptive terms, such as "scoring," "galling," etc., shall be included. Procedures shall be included for performing special inspections required when the equipment has operated beyond permissible limits.

3.5.4.1 Periodic and special inspection. Types of inspection requirements are classified as Periodic and Special.

- a. Periodic Inspection. This is a repetitive type of inspection to be accomplished on days of calendar time (30, 90, 180, etc.), operational hours or cycles, with the interval of time to be designated by the acquiring activity.
- b. Special Inspection. These inspections supplement other inspections and are accomplished because of specific circumstances or events. All special inspections shall be event oriented only.

3.5.4.1.1 Stating requirements. Each inspection requirement shall specifically state what condition is to be sought or the operation required to obtain a desired condition. The format for stating inspection requirements shall be by noun (nomenclature), as used in applicable maintenance manuals, for the condition(s) to be sought. Normally, more than one major item shall not be stated in the same requirement. If a requirement appears in more than one portion of the manual and the intended scope of the requirement is the same for

MIL-DTL-87929D

each inspection, each entry must be worded exactly the same. Further, the man-minute data, when included, shall also be identical. When magnetic particle, X-ray, or fluorescent penetrant inspection is required, a statement to this effect shall be included as a part of the requirement. In no case shall the statement of an inspection requirement explain procedures for removal of equipment or correction of trouble found as the result of inspection. The following type items shall not be included in the inspection requirements:

- a. Luxury items that do no harm if they fail.
- b. Items of a housekeeping nature.
- c. Checking for continuance of a static condition.

3.5.4.1.2 Inspection requirements. Inspection requirements shall be presented in the following format. Instructions for entries to each column follow:

Periodic/Special Inspection Requirements

Inspection Requirements	Type of Inspection		Applicability	Man-Minutes
	Periodic	Special		

3.5.4.1.2.1 Inspection requirements column. Each inspection requirement shall be clearly and concisely stated and shall identify exactly what condition is to be sought. The inspection requirements shall be grouped according to system, subsystem, end items or similar functional categories. The applicable system nomenclature and code number (two digit; i.e., System 11, 23, 56, BA, MA) shall be entered preceding each group.

- a. Preparation steps and special tools shall not be shown. This requirement is contained in the WP, technical manual or checklist that is referenced for each inspection requirement.
- b. Each inspection requirement entry shall reference the WP, technical manual or checklist that covers the requirement, as applicable.

3.5.4.1.2.2 Type of inspection column. Each type of inspection column shall be completed as follows:

- a. Periodic. The interval of time shall be placed opposite each applicable inspection requirement in the "Periodic" Column. The basic time interval shall be established by the acquiring activity.
- b. Special. In the "Special" Column, the condition or circumstance governing each applicable requirement shall be inserted. All special inspections shall be event oriented only.

3.5.4.1.2.3 Applicability column. This WP may apply to all models of a certain series and may, therefore, contain inspection requirements that are not applicable to the specific equipment configuration to be inspected. When this situation is encountered, only those requirements that are applicable, as indicated by the Applicability Column, should be accomplished. Entries made in the column shall show the applicable model or, when applicable, by Air Force Base (i.e. VAFB, DMAFB, LAFB).

3.5.4.1.2.4 Man-minutes column. The time in man-minutes required to accomplish each inspection requirement shall be entered.

3.5.4.2 Visual inspection. When applicable, procedures shall be prepared for visual, external inspection of the equipment. The information shall include purpose and conditions under which the inspections will be made. Equipment limits and specific information for interpretation of the equipment condition shall be given.

3.5.4.3 Sampling inspection. When applicable, certain inspections may contain procedures using sampling procedures; inspections shall consist of the usual inspections for defects, and other mechanical and electrical tests, as applicable. Defects shall be separated into critical defects, major defects, and minor defects. The inspection requirement shall also contain the number of allowable defects, how to handle and dispose of rejected items, and sampling charts.

3.5.4.4 Nondestructive Inspection (NDI). Unless covered in a separate manual, requirements for special nondestructive-type inspections, such as borescope, radiographic, magnetic particle, ultrasonic, eddy-current, X-ray, or liquid penetrant, shall be specified (see Appendix F).

MIL-DTL-87929D

3.5.4.5 In-process inspection. When applicable, assembly or reassembly procedures shall include in-process inspections that must be accomplished at those stages where further assembly would prevent access to perform the required inspection.

3.5.5 Maintenance.

3.5.5.1 Theory of operation. Theory of operation shall consist of a functional narrative written to provide the technician a thorough understanding of the equipment to support operation, fault detection and isolation (diagnostic), and maintenance. Schematic diagrams shall be used to support this text. This narrative shall completely describe the:

- a. Equipment operation.
- b. Equipment data flow.
- c. Equipment monitoring systems (electrical, mechanized, and manual).
- d. Equipment mechanized systems.
- e. Contribution made by the mechanical, electrical, fluid, and other elements of the system.
- f. System interfaces.

3.5.5.1.1 Functional divisions. When the functional divisions defined on the master block diagram are sufficiently complex, further division is necessary. In this case, intermediate and functional diagrams shall be provided to show the transition between major divisions on the master functional diagram. Additionally, the subordinate functional diagrams necessary to describe the theory of operation shall be included. Intermediate functional diagrams shall be prepared as necessary by dividing each functional block on the master diagram into discreet single page/view subfunctional diagrams.

3.5.5.1.2 Subfunctions. As necessitated by equipment complexity, block diagrams shall be prepared to further show the subfunctions of the equipment.

3.5.5.1.3 Composite. The composite of the functional diagrams shall be constructed to provide the user the clearest explanation of theory and understanding of the maintenance requirements of the equipment and accessories. Basic theory of operation shall be excluded; however, special or unique features shall be explained and illustrated.

3.5.5.1.4 Description of system tie-in of equipment and accessories. The integration of all equipment and accessories into an operational system shall be explained unless provided in another manual. When a system uses inputs from a different system or provides output to a different system, input sources and output destinations shall be explained and shall be shown in block diagrams. The explanation may be a narrative description, diagrams, or a combination of narrative description and diagrams of the tie-in of the equipment and accessories of the system.

3.5.5.2 Preparation for maintenance. Instructions shall contain procedures prior to inspection, repair, and replacement of parts specifically tailored to the level of maintenance to which the manual applies. Procedures shall include, but not be limited to, removal of equipment from shipping container, installation into stands/fixtures, and de-preservation. When appropriate, references to TO 00-25-203, "Contamination Control of Aerospace Facilities, US Air Force" shall be made. If references are not appropriate, specific limits for temperature, humidity, and particle control shall be provided.

3.5.5.2.1 Extreme weather maintenance. Any special procedures or processes required under extreme temperature and humidity conditions within the limits established by the design specification, shall be included.

3.5.5.2.2 Proprietary processes. Proprietary processes shall be identified. When a Government activity must be certified to apply a proprietary process, the conditions shall be stated.

3.5.5.2.3 Prefunctional check (electrical). Information shall be included to ensure no short circuits exist prior to testing. The following note may be included:

MIL-DTL-87929D

NOTE

It is not necessary to perform the following prefunctional checks unless reported deficiency of equipment to be repaired indicates an internal short circuit exists.

Procedures for manually testing electronic and electromechanical equipment shall also be provided when applicable.

3.5.5.2.4 Required conditions. Certain functions are dependent on the equipment being in a given condition. When required conditions can be obtained by performing other maintenance instructions, these instructions shall be indicated as prerequisite to the task. An example of a required condition is "Aircraft Safe for Maintenance."

3.5.5.3 Fault isolation (troubleshooting). The instructions shall contain procedures for performance testing and for locating and identifying the cause of the fault. Wherever possible this shall be done on a unit basis. However, where it is necessary to combine two or more items of equipment into a system or portion thereof, instructions for performance testing, and location and identification of the fault cause(s) shall be covered. In either case, the instructions shall be as follows:

3.5.5.3.1 Analysis. A fault isolation guide shall be provided in a logical step-by-step troubleshooting sequence which relates Support Equipment (SE) and/or component indications to specific detail parts or circuits which are most likely to have caused the problem and specifying the necessary adjustment, repair or replacement. A clearly defined path must be evident from the fault description to its probable cause and correction. The path must lead the technician to a definite and positive conclusion. A "closed loop" situation shall be avoided under all circumstances.

3.5.5.3.2 Bench test setup (when applicable). Figures shall be presented illustrating the suggested bench test setup showing:

- a. Details of intercomponent connections.
- b. Connections between test equipment and equipment or component under test for each procedure.

3.5.5.3.2.1 Identical test setup. When a number of separate procedures utilize identical test setups, one figure illustrating the setup shall be presented once, and not repeated. Appropriate reference to the figure number will suffice for each procedure. If a cable, hose, or line is to be connected to more than one connection during the procedure, an asterisk or other symbol shall be placed at the unconnected connector(s) on the test setup diagram to indicate that connection instructions will be given in the appropriate step of the test procedure.

3.5.5.3.3 Circuit analysis (detailed). Data shall provide input, internal, and output signal flow and the functions of assemblies, subassemblies, and detailed parts of the equipment in normal operating condition. Signal and voltage levels may be given to clarify operation. Schematic diagrams of partial circuits or stages may be prepared for clarity.

3.5.5.3.4 Test equipment. Instructions essential for proper use of test equipment in diagnosing trouble within a specific item of equipment shall be included within each procedure.

3.5.5.3.4.1 Cable fabrication. When cable assemblies are required for bench test setup, but are not supplied, instructions shall be provided for fabricating interconnecting cable assemblies from spares and bulk supplies. The part number, drawing number, and manufacturer or designer for each part of the cable assembly shall be shown, as well as identification of wires, connectors, pin connections, and letters or other designators.

3.5.5.3.5 Test data. Test values and acceptable tolerances shall be given for each test as applicable.

3.5.5.4 Disassembly. Instructions shall be given for the disassembly of the equipment into assemblies, subassemblies, components, and parts as required. Special tools to be used, precautions to be observed, critical dimensions to be recorded, shall be prescribed. All hardware items which are to be removed shall be specified by name. Instructions shall be included for matching, marking, or labeling for installation, any component(s) which could be installed incorrectly. This includes any cables, hoses, or lines which are disconnected during removal of an item if any possibility of incorrect installation exists. Special hardware items (nonstandard fasteners, brackets, or fittings slightly different from others in the same assembly) shall be specified by their identifying characteristics (i.e., longer, thicker, plastic). These characteristics shall also

MIL-DTL-87929D

appear as a callout on the illustration. When appropriate, instructions shall be included to retain items for reinstallation and to record position of items removed, such as number of shims at each attaching point.

3.5.5.4.1 Repair kits. When repair parts for the equipment are to be supplied in the form of kits, the following note shall be placed at the conclusion of the disassembly instructions:

NOTE

Certain repair parts for components covered in this publication are supplied in the form of kits. Refer to the applicable Illustrated Parts Breakdown (IPB) for details. Maintenance activities shall replace all parts, regardless of condition, which are removed during disassembly, with like parts furnished in the kit. Therefore, instructions for inspection, cleaning, and rework of the used parts have been omitted. If any parts in the kit must be inspected, cleaned, or tested prior to installation, instructions for performing these requirements are included in this WP. An installed part which is not defective need not be removed solely for the purpose of replacement by a corresponding kitted part.

3.5.5.5 Cleaning. Instructions shall describe any special cleaning methods required. The type of cleaning shall be specified, such as using a liquid, brushing away dust, blowing out with compressed air; if the latter, air pressure required shall be indicated. Requirements for special ventilation or controlled environment shall be indicated. Precautions to be observed shall be listed. Instructions for after cleaning relating to the preservation of metal parts and surface treatment (such as paint touch-up) shall be provided. Cleaning instructions in connection with nondestructive inspection methods shall be included. Special tools, jigs, and fixtures necessary during cleaning shall be indicated. General cleaning instructions shall be omitted.

3.5.5.6 Corrosion prevention. Instructions shall, when applicable, specify use of approved corrosion preventive compounds, neutralization, or other protection on parts and components. Materials and methods for touch-up or repainting shall be included as applicable.

3.5.5.7 Lubrication. All parts which require lubrication shall be identified. The type of lubricant to be used and frequency of application shall be specified. Tabular format is recommended.

3.5.5.8 Repair and replacement. Comprehensive instructions shall be provided for necessary repair and replacement operations to restore the equipment to a serviceable condition. Repair methods shall be specified for the correction of all deficiencies and conditions considered repairable within the scope of the level of maintenance to which the manual applies. Specific data shall be provided to adequately describe acceptable repairs, including material specifications pertinent to making repairs. The application and operation of special tools and test equipment shall be described.

3.5.5.8.1 Piping and clamping. Detailed instructions shall be provided for proper routing, connection, and clamping of tubes, cables, and hardware unless covered elsewhere.

3.5.5.8.2 Fabrication. Instructions shall be included for local fabrication of all component parts source coded as "local manufacture."

3.5.5.9 Assembly. Detailed step-by-step instructions shall be included for assembly of component parts into major subassemblies to form a complete end item. Assembly instructions to include all pertinent assembly criteria such as clearances, backlash dimensions, special torque values, peculiar safety wiring, end play, and similar data, shall be provided. Appropriate tests for operation of a subassembly prior to final assembly shall be provided, including safety precautions to be observed. Instructions for rigging, adjustment, and alignment, when required, shall be included in logical sequence. All corrosion preventive compounds, special lubricants, and other consumables required for assembly shall be specified. Any inspections, lubrications, or adjustments, which must be performed prior to mating of subassemblies (which cannot be accomplished at a later point in the assembly), shall be identified. Instructions for requirements shall be integrated into the procedure, as applicable. Assembly instructions, such as "Reverse the Disassembly Sequence", shall not be used except on very simple items. Reference to the applicable procedure for checkout of the item shall be made at the end of the assembly instructions.

MIL-DTL-87929D

3.5.5.9.1 Marking and stenciling. Methods and materials for replication of stenciling, marking, and decalomania which may have been damaged or obliterated, or to indicate overhaul, shall be provided.

3.5.5.9.2 Installation of hardware. All hardware items which are to be installed shall be specified by name. Instructions shall refer to any items which were retained during removal and to any record of item position. No items shall be installed which must be immediately removed in a required subsequent function or follow-on task.

3.5.5.10 Servicing. Instructions shall include procedures for checking, replenishing, sampling, and priming of fuel, lubrication, and hydraulic systems. Capacities, with allowance for expansion, government specification number and grades for fuels, oils, and fluids shall be given.

3.5.5.11 Testing. Instructions shall be included for aligning, adjusting, testing, and calibrating the equipment after reassembly. Test point, test values, and acceptable tolerances shall be given for each test, as applicable. Corrective action shall also be described for failures of equipment to meet the necessary tests. This may be in the form of a troubleshooting table, if appropriate, showing trouble, probable causes, and remedy. As far as possible, the corrective actions shall specify adjustments which can be made without disassembling the equipment.

3.5.5.12 Operational checkout. Operational checkout functions required after maintenance shall be included. All primary equipment and test set turn-on and warm-up procedures shall be included. If procedures are extensive and are outlined in detail elsewhere, they shall be referenced. If obvious, immediate and simple corrective actions, as indicated by certain no-go conditions, shall be included in the procedures.

Print presentation: If a no-go condition in an operational checkout can be corrected by an adjustment procedure requiring less than two pages, such procedures may be incorporated into the operational checkout as a task of the checkout.

Electronic presentation: If a no-go condition in an operational checkout can be corrected by an adjustment procedure it shall be presented in a scrollable view and such procedures may be incorporated into the operational checkout as a task of the checkout.

3.5.5.13 Follow-on maintenance. If, upon completion of a maintenance action, further maintenance is required to return the equipment to operational readiness, it shall be termed "Follow-on maintenance." References to applicable TM/WPs must be provided as a part of the function to return the equipment to the required condition/configuration.

3.5.5.14 On-condition maintenance.

3.5.5.14.1 Equipment assembly/disassembly. Instructions shall contain procedures preliminary to inspection, repair and replacement of parts during on-condition maintenance. Procedures shall include both dismantling into major sections for further maintenance and final assembly of major sections prior to operational check.

3.5.5.14.2 Assembly/disassembly of major sections and subassemblies. Instructions shall contain procedures necessary to complete dismantling, inspection, repair, and assembly of major sections/subassemblies during on-condition maintenance.

3.5.5.15 Accessory maintenance. Instructions shall contain step-by-step procedures for removal and installation of individual accessories from assembled equipment. Instructions shall be provided for inspections, adjustment, troubleshooting, minor repair, on-condition maintenance (when applicable), and testing. When it is necessary to provide data, each accessory shall be treated as a separate entity and complete instructions shall be provided. For accessories having separate TMs covering maintenance, suitable reference shall be made to applicable accessory TM number. This shall be done in tabular form, cross-referencing part number and nomenclature to publication number.

3.5.5.16 Scheduled maintenance. Scheduled maintenance required by operational event (i.e., hours, cycles, temperature, counts, calendar time) shall be covered.

3.5.5.16.1 Replacement schedule. This schedule lists units of operating equipment that are to be replaced periodically and specifies how often they are to be replaced. Replacement intervals are indicated by operational event. Replacement shall be accomplished during the inspection period occurring nearest to the replacement time specified in this schedule.

MIL-DTL-87929D

3.5.5.16.1.1 Contents. The replacement schedule shall contain a listing of those items of equipment to be replaced at the expiration of an interval of calendar time. Where this is not feasible, replacements should be accomplished by operational event or at the occurrence of a specific condition. The replacement components shall be segregated according to the major items on which usage data shall be maintained. This shall be accomplished by identifying the major items in the nomenclature and part number column. This shall be followed with a listing of all time change components contained within the major item.

3.5.5.16.1.2 Format. Entries to the Replacement Schedule shall be as follows:

Replacement Schedule

Replacement Frequency	System No.	Nomenclature Part No.	Quantity	Man-Minutes
-----------------------	------------	-----------------------	----------	-------------

- a. Replacement Frequency. The replacement frequency of each item shall be entered in this column. Replacement frequencies shall be listed in calendar time and aligned with scheduled inspections. If replacement frequencies for non-calendar life items cannot be converted to calendar time, the replacement frequencies shall be stated by operational event.
- b. System No. The system code number (reference applicable work unit code manual) to which the major item and subordinate replacement items apply, shall be entered in this column.
- c. Nomenclature and Part No. The nomenclature and part number of the major item and each replacement item shall be entered. Replacement components under the major item shall be indented.
- d. Quantity. The quantity of the item, as applicable, shall be entered.
- e. Man-Minutes. The time in man-minutes required to replace the item, including time required to gain access to the item, shall be entered.

3.5.5.17 Programmed Depot Maintenance (PDM). When applicable, data shall be included to enable repair activities to determine when components, assemblies, and subassemblies require maintenance or repair, or when they shall be completely overhauled. Processing instructions shall be included to cover inspection, the extent of disassembly necessary, and the detailed mandatory parts replacement information applicable to time replacement and forced removal components.

3.5.5.17.1 Inspection tables. Tables shall be included for textual presentation of inspection data in a tabular format. The tables shall contain the following headings:

Inspection Table

Inspect	Max Serviceable Limits	Max Serviceable Limits	Corrective Action
---------	------------------------	------------------------	-------------------

- a. Inspect. Identifies the component or item being inspected.
- b. Max Serviceable Limits. Identifies the maximum limits to continue a component or item in service.
- c. Maximum Repairable Limits. Identifies the maximum repair or rework permitted to continue a component or item in service.
- d. Corrective Action. Identifies the corrective action required to return the component or item to serviceable condition.

3.5.6 Preparation for shipment and storage. Procedures shall be provided for any maintenance requirements (i.e., purging, draining, servicing, or sealing) prior to packaging.

3.5.6.1 Preservation and packing. Procedures shall be provided for preserving the equipment and preparing for storage. Procedures shall also be provided for packing the equipment/components in appropriate containers, and shall include applicable shipping and storage instructions. Dimensions and weight of the shipping and storage container with equipment and/or modules packed for shipment shall be given.

MIL-DTL-87929D

Information shall be provided for the prevention, recognition, and elimination of corrosion. Specific instructions shall be provided for equipment concerned with reference to general series manuals as necessary.

3.5.6.1.1 Special packing. When applicable, packing shall be accomplished in accordance with Special Packaging Instructions (SPI) and reference shall be made to the applicable SPI. Components shall be packed in original containers, when possible, utilizing shipping plugs/caps as required. Explosive components of the missile are packed in accordance with TO 00-85-series technical orders and shall be referenced. Show all shipping and storage containers in tabular format. Receiving inspections shall be in accordance with 3.5.1.2. Acquiring activity shall identify container marking requirements.

3.5.6.2 Closing and sealing. Instructions for closing of containers, torquing bolts, and any other final operations required to prepare containers for shipment, or return to storage, shall be provided.

3.5.6.3 Shipping and storage. Shipping and storage procedures shall be in accordance with regulations applicable to the specific equipment involved. Empty shipping containers and dunnage should be retained for future use.

3.5.7 Storage inspection. For equipment (tanks, racks, adapters, pylons, etc.), "Ready" and "Extended Storage" categories of inspection shall be explained and storage and maintenance requirements shall be provided. As a minimum, maintenance and inspection criteria shall be provided in the following chart form:

Inspection and Maintenance Criteria

Nomenclature	Inspect For	Repair	Ready Storage	Extended Storage
--------------	-------------	--------	---------------	------------------

3.5.7.1 Degrees of storage. The acquiring activity shall determine the inspection frequency for weapons release equipment in ready storage (see 6.2h.) The following text, with appropriate paragraph numbering, shall be included in the maintenance procedures:

“X. STORAGE INSPECTION.

Different degrees of inspection are required based upon the type of storage:

X.X. Ready Storage. Equipment maintained in a completely ready status in anticipation of a relatively near term use requirement. This equipment may be positioned on the shelf, held in the shop, or may be installed in the next higher assembly or installation. The item may be preloaded with munitions and maintained in a munitions holding area or munitions storage igloo in preparation for installation on the aircraft. Equipment shall be provided adequate protection from damage and the elements. Examples of ready storage would be DD 780 equipment receiving frequent use, and mobility contingency, or bare base assets requiring a high degree of readiness for immediate employment. Inspection interval for items placed in ready storage shall be that deemed necessary by the Item Manager/System Manager to assure serviceability in "ready-to-use" condition. For weapons release equipment, the inspection frequency on items in ready storage shall be a minimum of every (xx) months.

X.X. Extended Storage. Those items maintained in a ready condition for which no requirement exists for frequent exercises or immediate short term employment. Equipment placed in extended storage shall be in a serviceable, ready-to-use condition. This category includes War Reserve Material assets.

X.X.X. Inspection Criteria. An annual sampling inspection shall be performed of percent of all assets in extended storage. Items inspected shall be identified and marked to prevent redundant inspection of the same items during future annual inspections. Subsequent annual inspections shall be performed on those items which have acquired the longest calendar year time period since last inspection. In the event that deterioration of equipment is detected during any annual inspection, a determination shall be made whether an inspection of all assets having corresponding packaging dates must be performed. For field organizations, this determination shall be made either by the organizational commander or maintenance supervisor. For AFMC depot organizations, this determination shall be made by the supply inspector.

X.X.X. Storage and Packaging. Equipment placed in extended storage shall meet the following criteria:

- a. Equipment shall be packaged in accordance with applicable transportation packaging order.

MIL-DTL-87929D

- b. Packaged equipment must be warehoused in a covered structure which will provide protection from climatic elements.
- c. Units which have been subjected to prior use must meet all criteria prior to being placed in extended storage.
- d. Items received from depot or in base supply assets, meeting the packaging requirements specified in READY STORAGE above, shall be considered as being in extended storage.

3.6 Special technical manuals development. Equipment operation and maintenance procedures shall be documented in accordance with the preceding instructions. However, certain equipment characteristics require unique operation and maintenance procedures, unusual support requirements, and other considerations that require additional specific information be furnished, as applicable, in the form of special manuals.

Appendices B thru L provides the information for obtaining the DTDs for electronic delivery of the specialized WP manuals. When specified (see 6.2i.) these special manuals shall be developed in accordance with the WP/SWP concept previously determined. As a minimum, WP/SWP shall be arranged as follows:

- a. Front Matter (see 3.4.1.1).
- b. Alphabetical Index (WP 001 00) (see 3.4.3.1).
- c. Foreword (WP 002 00) (see 3.4.3.2).
- d. Master List of Special Tools, Test Equipment and Consumables (WP 003 00) (see 3.4.3.3).
- e. Technical WP/SWPs (meeting the requirements of 3.4.3.4) shall include the specialized or unique technical procedures as described for the following various special manuals:
 1. Aircraft Engine Testing and Trending Procedures Manual (see Appendix B).
 2. Aircraft Power Package (Engine Installation Hardware Configuration) Testing Procedures Manual (Appendix C).
 3. Static Firing of Missile Motors Manual (see Appendix D).
 4. System Peculiar Corrosion Control Manual (see Appendix E).
 5. Nondestructive Inspection (NDI) Manual (see Appendix F).
 6. Aircraft Structural Integrity Program (ASIP) Manual (see Appendix G).
 7. Automated Test Equipment (ATE) Operator Test Procedures Manual (see Appendix H).
 8. Specialized Storage and Maintenance Procedures; AUR Munitions and Associated Support Equipment, Conventional Components, and CMBR Agents Manual (see Appendix I).
 9. Parachute Packing Procedures Manual (see Appendix J).
 10. Operators Instructions (Hand-Held Flight Computers) Manual (see Appendix K).
 11. Installation-Engineering Facility (Ground C-E Equipment) Manual (see Appendix L).

4 VERIFICATION.

4.1 Verification requirements. When the technical data produced according to this specification is offered for acceptance, all tests, reviews, and verifications required by the PM to determine that it conforms to the requirements in section 3 of the specification, shall be performed as specified in the solicitation or contract. The Air Force Technical Order Policy and Procedures (AF TOPP) team, AFMC/A4UE, provides the specific requirements for verification of technical data developed and delivered through this specification, as well as guidance for including these requirements in the solicitation or contract (see TO 00-5-3, AF Technical Order Life Cycle Management, 2.2.2).

4.2 Compliance. Technical Manuals (TMs) shall meet all requirements of section 3 of this specification (see 6.2) and the appropriate DTD appendix, as required by the PM. The requirements set forth in this specification shall become a part of the contractor's overall inspection system or quality program. The absence of any requirements in this specification shall not relieve the contractor of the responsibility of ensuring that all products or supplies, submitted to the government for acceptance, comply with all

MIL-DTL-87929D

requirements of the contract. Use of sampling inspections shall be at the discretion of the contractor, and in accordance with commercially acceptable quality assurance procedures. However, use of sampling in QA procedures does not authorize submission of known defective material, either indicated or actual, nor does it commit the government to accept defective material.

5 PACKAGING

5.1 Packaging. For acquisition purposes, the packaging requirements shall be as specified in the contract or order (see 6.2.1.). When actual packaging of materiel is to be performed by DoD personnel, these personnel need to contact the responsible packaging activity to ascertain requisite packaging requirements. Packaging requirements are maintained by the Inventory Control Point's packaging activity within the Military Department or Defense Agency, or within the Military Department's System Command. Packaging data retrieval is available from the managing Military Department's or Defense Agency's automated packaging files, CD-ROM products, or by contacting the responsible packaging activity.

6 NOTES

(This section contains information of a general or explanatory nature that may be helpful, but is not mandatory.)

6.1 Intended use. Technical manuals prepared in accordance with this specification are intended to be used for accomplishing military specific operation, inspection, maintenance, storage, and other specialized tasks on Air Force equipment.

6.1.1 WP concept. The objective of the WP concept is to present a self-contained set of procedures based on work area requirements to support significant Operation and Maintenance (O&M) tasks. Division of O&M information into specific WPs depends on the operational modes and complexity of the O&M actions and the level of O&M to be covered. Each WP or SWP is an independent, task/process oriented unit using a minimum amount of references within a TM. Text is factual, concise, comprehensive, and readily understandable to personnel with a minimum of training and experience in the area where the data will be used.

6.1.2 Application. The WP/SWP concept applies to the operation and maintenance of system components removed from their host system or from their higher assembly (i.e., off-equipment). A WP may also be used for a total system when the system is small enough to make it cost effective. Complexities and maintenance concepts dictate how WPs and SWPs will be developed for given equipment. Relatively simple, non complex equipment may require a TM with only a few WPs containing all of the O&M procedures. Complex equipment however, may require a set of TMs, each manual with a full set of WPs and, when applicable, a number of SWPs to further manage and focus the information for specific maintenance work stations or specific operations.

6.2 Acquisition requirements. Acquisition documents must specify the following:

- a. Title, number, and date of this document.
- b. If the manual is to be prepared in single or double column format (see 3.1).
- c. The type, quantity and breakout of manuals comprising a maintenance manual set (see 1.1, 3.2.1).
 1. Organizational level maintenance (O-Level) (see 3.2.1.2).
 2. Intermediate level maintenance (I-Level) (see 3.2.1.1).
 3. Depot level maintenance (D-Level) (see 3.2.1.3).
 - (a) Horizontal or vertical maintenance (engines and missiles) (see 3.2.1.3).
 - (b) Maintenance concept (conditional maintenance or total overhaul) (see 3.2.1).
 4. Combined I- and D-Level maintenance manuals (see 3.2.1.4).
 5. On-condition maintenance instruction manual (see 3.2.1.5).
 6. If a manual set is to be prepared (see 3.2.1.6).
 7. If manuals are to be prepared for major accessories (see 3.2.1.7).
 8. Combined operation and maintenance (see 3.2.2).

MIL-DTL-87929D

- d. If a master list of containers is required (see [3.4.3.3.4](#)).
- e. If repair of special tools and test equipment is to be included (see [3.4.3.3.5](#)).
- f. If instructions for local manufacture of tools/equipment are to be included (see [3.4.3.3.6](#)).
- g. If IPB is to be included (see [3.4.3.5](#)).
- h. If an inspection interval is required for weapons release equipment in ready storage (see [3.5.7.1](#)).
- i. If specialized manuals are required (see [3.6](#)).
 - 1. Aircraft Engine Testing and Trending Procedures Manual (see Appendix [B](#)).
 - (a) If testing and trending procedures is to be a WP in the engine maintenance manual(s) (see Appendix [B.3.1](#)).
 - 2. Aircraft Power Package (Engine Installation Hardware Configuration) Testing Procedures Manual (see Appendix [C](#)).
 - 3. Static Firing of Missile Motors Manual (see Appendix [D](#)).
 - 4. System Peculiar Corrosion Control Manual (see Appendix [E](#)).
 - 5. Nondestructive Inspection (NDI) Manual (see Appendix [F](#)).
 - 6. Aircraft Structural Integrity Program (ASIP) Manual (see Appendix [G](#)).
 - (a) If detailed system information for flight data gathering programs is to be included (see [G.3.1.4](#)).
 - 7. ATE Operator Test Procedures Manual (see Appendix [H](#)).
 - 8. Specialized Storage and Maintenance Procedures; AUR Munitions and Associated Support Equipment, Conventional Components, and CMBR Agents (see Appendix [I](#)).
 - (a) If the table of contents is to contain second level subordinate paragraphs (see [I.3.2](#)).
 - (b) If other inspections are to be included and, if so, the categories and types (see [I.3.5.5.1.8.2](#)).
 - (c) If a humidity indicator inspection cycle table is required (see [I.3.5.5.1.8](#)).
 - (d) If a configuration table is to be included and, if so, the required column headings (see [3.5.1.4](#)).
 - (e) If a depot related data and special instructions WP is to be included and, if so, what appropriate data is to be included (see [I.3.5.11](#)).
 - (f) If procedures for containers are not to be included (see [I.3.3](#)).
 - (g) If WPs 110 00 through 997 00 or SWPs are to be used and if so, the arrangement and breakout to be used (see [I.3.5](#)).
 - (h) If other WP/SWPs are to be included and the type of information required (see [I.3.5b](#), (4), [I.3.5.12](#)).
 - (i) If a configuration table is to be included and if so, the required column headings (see [I.3.5.1.4](#)).
 - (j) If special tools are to be illustrated elsewhere in the manual or not illustrated (see [I.3.5.3.4](#)).
 - (k) If test equipment is to be illustrated elsewhere in the manual or not illustrated (see [I.3.5.3.5](#)).
 - (l) If sample size for periodic inspections (PI) is other than specified (see [I.3.5.5.1.3](#)).
 - (m) Whether the IPB may be prepared as a separate WP or as a separate manual (see [I.3.5.8.2](#)).
 - (n) If a Testing/Reprogramming WP will be included (see [I.3.5.9](#)).

MIL-DTL-87929D

(o) If a Contingency Procedures WP will be included (see [I.3.5.10](#)).

(p) If a chemical munitions/biological research agents manual is to be prepared (see [I.3.6](#)).

9. Parachute Packing Procedures Manual (see Appendix [J](#)).

(a) Required inspection intervals (see [J.3.2.2](#)).

10. Operators Instructions (Hand-Held Flight Computers) Manual (see Appendix [K](#)).

11. Installation-Engineering Facility (Ground Communication-Electronic [C-E] Equipment Manual (see Appendix [L](#)).

j. If checklists are to be prepared (see [3.2.4](#)).

k. If responsibility for inspection is to be other than as specified in this document (see [4.1](#)).

l. Packaging requirements as specified in [5.1](#).

6.3 Technical manual. The requirement for technical manuals should be considered when this specification is applied on a contract. If technical manuals are required, specifications and standards that have been authorized and assigned an Acquisition Management Systems Control (AMSC) number must be listed on a separate Contract Data Requirements List (DD Form 1423), which is included as an exhibit to the contract. The technical manuals must be acquired under separate contract line item in the contract.

6.4 Definitions.

6.4.1 Cautions. A caution is a short message which calls attention to an essential operating or maintenance procedure, practice, condition, statement, etc., which, if not strictly observed, could result in damage to, or destruction of equipment or loss of mission effectiveness.

6.4.2 Consumables. Sealants, lubricants, gaskets, seals, cleaning solvents, and paint are considered consumable materials.

6.4.3 Nonnuclear munitions. Nonnuclear munitions are: nonnuclear bombs, fuzes, warheads, missiles, pyrotechnics, chemical/biological materials. Items such as impulse cartridges, jettison charges, training items, ammunition, and other non-aircraft inventory items will be considered similar or relative to nonnuclear munitions.

6.4.4 Notes. A note is a short message which describes an unusual procedure or condition to which special attention must be paid for any reason. A note may not replace a warning or caution.

6.4.5 Replacement. Replacement means removal of the equipment and installation of a new or newly overhauled item in its place.

6.4.6 Special containers. For the purpose of this specification, a special container is defined as a container that has been designed and fabricated to meet specific requirements, such as configuration, environmental control, impact protection, accessory, and hardware storage, for a specific item.

6.4.7 Verification. Verification, in the context of this specification, equates to the contractor's quality assurance program for validating the content of the WP/SWP. Suggested validation methods include:

a. Actual performance. Using production configured equipment, hands-on performance of the procedure using the technical instructions as written.

b. Simulation. Using production configured equipment and the technical manual procedure, simulate the actions required by comparing the task steps to the hardware, while not actually removing any equipment.

c. Table top analysis. Primarily for non-procedural data, compare the technical content to source data to ensure the technical accuracy and depth of coverage.

6.4.8 Warnings. A warning is a short message which calls attention to an essential operating or maintenance procedure, practice, condition, statement, etc., which, if not strictly observed, could result in injury to, or death of personnel or long term health hazards.

MIL-DTL-87929D

6.5 Subject term (key word) listing.

- Depot Level Maintenance
- Engineering Change Proposals
- Intermediate Level Maintenance
- Maintenance Concept
- Organizational Level Maintenance
- Servicing Operation
- Subordinate Work Package
- Verification

6.6 Changes from previous issue. Marginal notations are not used in this revision to identify changes with respect to the previous issue due to the extent of the changes.

MIL-DTL-87929D

TO 2J-F110-16-3
WP 005 00

WORK PACKAGE

TECHNICAL PROCEDURES

MANUAL TITLE⇒

ACCESSORIES

WP TITLE⇒

MAIN FUEL SYSTEM
REMOVAL AND INSTALLATION

EFFECTIVITY: Engine Model F110-G5-129

LIST OF EFFECTIVE WP PAGES

Total number of pages in this WP is 26 consisting of the following:

* Zero in this column indicates an original page.

Page No.	*Change NO.	Page No.	*Change NO.	Page NO.	*Change NO.
1-25.....	0	26 blank.....	0		

TABLE OF CONTENTS

<u>PARAGRAPH</u>	<u>PAGE</u>	<u>PARAGRAPH</u>	<u>PAGE</u>
Fuel Boost Pump - Removal	15	Main Fuel Filter - Inspection	10
Main Fuel Control - Installation	25	Main Fuel Filter - Installation	14
Main Fuel Control - Removal	12	Main Fuel Filter - Removal	3

1

FIGURE 1. Sample work package title page

MIL-DTL-87929D

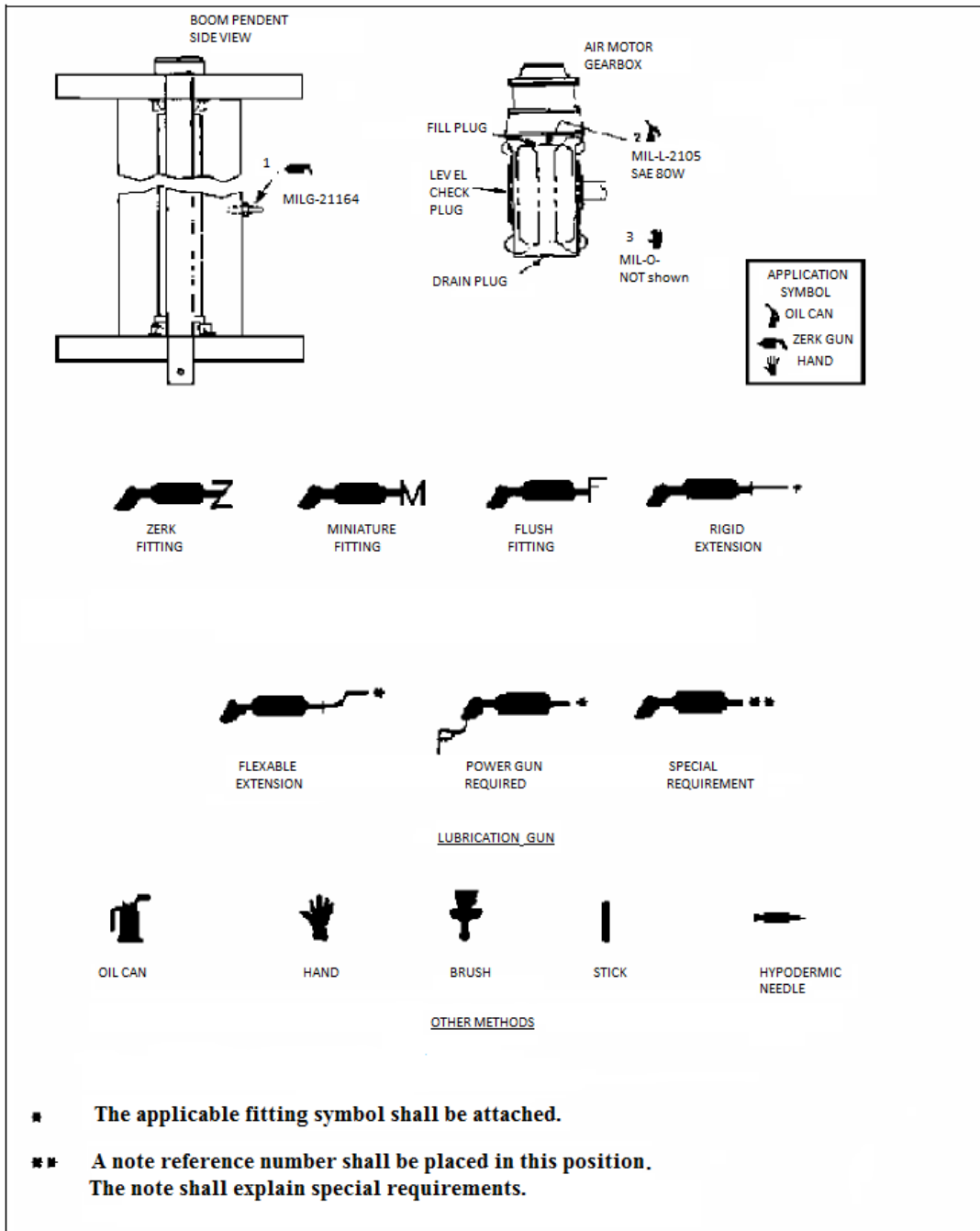

FIGURE 2. Sample of lubrication and illustration symbols

MIL-DTL-87929D**APPENDIX A****BASIC WORK PACKAGE TYPE MANUAL
DOCUMENT TYPE DEFINITION (DTD) SUBSET****A.1 SCOPE.**

A.1.1 Scope. DTDs are based on rules outlined in MIL-PRF-28001 and ISO 8879. The DTD subset referenced within this appendix provides the structure and content templates of documents prepared in accordance with this detail specification. For digital copies of the DTD, see [A.4.3](#). This appendix is a mandatory part of this detail specification. The information herein is intended for compliance.

A.2 APPLICABLE DOCUMENTS.

Not applicable.

A.3 DIGITAL SUPPORT SUITE (DSS).

The DSS is comprised of the following tools for authoring and rendering the Basic Work Package Type manual doctype.

A.3.1 DTD. The Basic Work Package Type DTD provides the structure and content template in accordance with this detail specification. To be delivered digitally, the Basic Work Package Type manual shall be tagged using the applicable DTD found at the Technical Manual Specifications and Standards (TMSS) activity website (see [A.4.1](#)).

A.3.2 Tag Description Table (TDT). TDT provides detailed descriptions of the elements contained in the Basic Work Package Type manual DTD. The TDT contains the element tagging structure, full element name, tag minimization requirements, element structure, reference elements, source paragraph, and attribute descriptions unique to the element. See [A.4.1](#) for information on obtaining this file in digital format.

A.3.3 Attribute Description Table (ATD). ATD provides detailed descriptions of the attributes contained in the Basic Work Package Type manual DTD. See [A.4.1](#) for information on obtaining this file in digital format.

A.4 OBTAINING FILES.

A.4.1 Obtaining files with a .mil address. Obtaining DSS files with a .mil address.

A.4.1.1 TMSS web site. DTDs, TDTs, and other files in the DSS can be accessed at the TMSS website at <https://techdata.wpafb.af.mil/tmss/index.html>. On the web page, the “Baseline” menu option in the left pane contains three bulleted options called “Specifications”, “Standards”, and “Handbooks”. Hover the cursor over “Specifications” and a listing of the TMSS specifications will appear. Hover over the desired specification number and another drop down list will appear that shows a list containing a PDF version of the specification and the associated appendices. To obtain the preferred DTD, select the desired appendix. The following items will appear on the downloading page: The name of the specification, the appendix number and name, the current version of the DSS, buttons to download the DTD, FOSI, screen FOSI, ATD, and the TDT, and a “Download” button to download the entire DSS zip file.

A.4.1.2 TMSS Community of Practice (CoP). For access to the TMSS CoP use the following web address: <https://afkm.wpafb.af.mil/community/views/home.aspx?Filter=OO-LG-MC-38>.

A.4.2 Obtaining files without a .mil address. For addresses other than .mil., information can be obtained through the Program Management Office (PMO) or see [A.4.3](#).

A.4.3 TMSS support. Please address any comments or questions relating to the DSS to SGMLSUPPORT@wpafb.af.mil or by mail to Technical Manual Specifications and Standards, ESC/HGGI, 4170 Hebble Creek Road, Building 280, Door 15, Wright-Patterson AFB OH 45433-5006.

MIL-DTL-87929D**APPENDIX B****SPECIAL REQUIREMENTS FOR AIRCRAFT ENGINE TESTING AND TRENDING PROCEDURES TECHNICAL MANUAL****B.1 SCOPE.**

B.1.1 Scope. This appendix provides the special or unique criteria, in addition to the provisions of this specification, required for development of an aircraft engine testing and trending procedures Technical Manual (TM). The information contained in and referred to in this appendix forms a part of the specification and is intended for compliance. The Document Type Definition (DTD) referenced herein may be obtained directly from the preparing activity (see [A.4.3](#)).

B.2 APPLICABLE DOCUMENTS.

B.2.1 This section is not applicable to this appendix.

B.3 SPECIAL REQUIREMENTS.

B.3.1 Aircraft engine testing and trending procedures manual. This manual shall provide instructions for conducting test of the complete engine. When specified, the testing and trending procedures shall be a WP in the engine maintenance manual(s). Test data pertaining to specific testing conditions, test set up and operating procedures of applicable support equipment shall be included.

- a. The following, as applicable, shall be included:
 1. Safety Precautions.
 2. Preparation for Test.
 3. Instrumentation Requirements.
 4. Engine Static Test and Motoring Procedures.
 5. Engine Starting, Operating, and Shutdown Procedures.
 6. Operating Limits.
 7. Level of Testing Following Specific Repairs.
 8. Engine Functional Test and Performance Evaluation MIL-DTL-87929) Appendix B.
 9. Test Schedule.
 10. Penalty Schedule.
 11. Fluid and Electrical Supply Requirements.
 12. Drainage Requirements.
- b. If an item has been provided for testing the engine, instructions for its use shall be provided.
- c. Allowable engine performance data corrected to standard day atmospheric conditions shall be included. Performance evaluation charts or curves shall be provided. Correction charts shall be included to show correction factors for performance evaluation.
- d. If engine performance is to be evaluated through use of Aircraft Integrated Data System (AIDS), provisions shall be included for compilation of data and establishment of the engine condition indication baseline. Data shall be presented in such a manner that diagnosis of mechanical or performance problems or trends toward potential problems may be evaluated through the use of AIDS. The instructions shall specify that these data will remain with the engine during maintenance for comparative use.
- e. The sequence and method of accomplishing a functional test or performance evaluation of the engine shall be included. All checks and adjustments shall be described in detail with appropriate references to charts or curves. For performance evaluation, a test schedule shall be provided in tabular form.

MIL-DTL-87929D**APPENDIX B**

- f. A table shall be included outlining the additional testing required for parts reinstalled or replaced following successful completion of a performance run. The table shall contain the following headings:

Penalty Applications

Part No.	Nomenclature	Reinstallation Test	Replacement Test	Remarks
----------	--------------	---------------------	------------------	---------

- g. A paragraph reading substantially as follows shall be inserted immediately following the Penalty Application table: "Parts removed to gain access to other parts or areas shall invoke the same penalties, in accordance with the table of penalty applications, as parts removed to correct deficiencies and malfunctions. In the event that more than one penalty is invoked, the most severe shall apply."

MIL-DTL-87929D**APPENDIX C****SPECIAL REQUIREMENTS FOR AIRCRAFT POWER PACKAGE
(ENGINE INSTALLATION HARDWARE CONFIGURATION) TESTING
PROCEDURES TECHNICAL MANUAL****C.1 SCOPE.**

C.1.1 Scope. This appendix provides the special or unique criteria, in addition to the provisions of this specification, required for development of a technical manual (TM) for Aircraft Power Package Testing Procedures (Engine Installation Hardware Configuration). The markup tags described herein are based on rules outlined in MIL-HNDBK-28001 and ISO 8879. The information contained in and referred to in this appendix forms a part of the standard and is intended for compliance. The Document Type Definition (DTD) referenced herein may be obtained directly from the preparing activity (see A.4.3). This technical manual requirement shall apply when test facilities have been provisioned and the using command maintenance plans require test and trim of removed power packages.

C.2 APPLICABLE DOCUMENTS.

Not applicable.

C.3 SPECIAL REQUIREMENTS.

C.3.1 Testing procedures manual. This manual shall include testing procedures for aircraft power package in engine installation hardware configuration with the power package removed from the aircraft. All essential information required to install the power package in the test stand, conduct tests, adjust engine trim, analyze any malfunctions evidenced during test, and remove the power package from the test stand shall be included. Instructions shall include a functional test of all power package components remotely controlled by or having indicators in the cockpit.

C.3.1.1 Testing facility WP. A brief description of the entire test facility and functional descriptions of the controls and indicators used and monitored during power package testing shall be included. Illustrations shall be provided to portray control panels and indicators peculiar to testing of specific power packages. Calibration requirements for peculiar test instrumentation shall include the frequency of calibration and required accuracy of instruments only. Reference to applicable instrument manuals for calibration instructions shall be made.

C.3.1.2 Preoperative procedures WP. Detailed step-by-step instructions for all preliminary operations required prior to performing a power package test run shall be included. Instructions shall include:

- a. Initial preparation of test area.
- b. Engine transfer from transportation dolly to run-up dolly.
- c. Installation and positioning of equipment and special tools required for test.
- d. Engine inspection.
- e. Installation of run-up dolly in test facility.
- f. Servicing instructions.
- g. Hook up of all control and instrumentation connections (at engine and test facility) and preliminary leak check.
- h. Final preparation of test area.
- i. Positioning of power switches and circuit breakers.
- j. Engine anti-icing valves check (check both engine anti-icing valves and nose cowl anti-icing valves).
- k. Ignition system check.
- l. Constant Speed Drive (CSD) oil system priming (if applicable).
- m. Oil sampling (if applicable).

MIL-DTL-87929D**APPENDIX C**

C.3.1.3 Operating procedures WP. Step-by-step operating procedures, charts, graphs, electrical schematics, and flow diagrams necessary to perform the power package test shall be included. Instructions shall include, but are not limited to, the following:

- a. Pre-trim preparation instructions.
- b. Test reference table.
- c. Temperature limit charts for engine starting, acceleration, and stabilized conditions.
- d. Trim time limitation figure.
- e. Trim target charts shall be prepared and properly annotated to indicate correction factors when using closed type cells, inlet screens, or sound suppressors.
- f. Chart for determining depression factors.
- g. Engine starting, shut down, and emergency shut down procedures.
- h. Engine fuel flow and engine oil system pressure check.
- i. Engine revolutions per minute (RPM) indicating system check.
- j. Engine breather check.
- k. Alternator functional check - (Use exciting A1A Load Bank) Engine vibration shall be taken during loaded condition. A token load may be required during run to prevent damage to the system.
- l. Exhaust gas temperature (EGT) harness check - Spread check and average shall be made with existing equipment.
- m. Exhaust pressure ratio (EPR) system check (if applicable).
- n. Bleed valve functional check (use EPR limits).
- o. Fuel pump output pressure.
- p. PT7 pressure measurement.
- q. Anti-ice functional check.
- r. Engine oil temperature measurement.
- s. Oil consumption check, curves, etc.
- t. Hydraulic pump functional check (using system comparable to M37).
- u. Generator checkout.
- v. Trim procedures in step-by-step form.
 1. Trim checks shall include simulated wet trim for temperature presently authorized.
 2. N1 and N2 RPM (engine conditioning and overspeed check).
 3. Field cleaning (carbo-blast).
 4. Vibration analysis check.
 5. EGT spread check.

C.3.1.4 Trouble analysis WP. Troubleshooting tables and procedures shall be included. Electrical schematics and flow diagrams, as an aid to troubleshooting, and engine system checkouts shall be provided as required. Remedies shall be brief and concise. The table shall also contain references to test points shown on the diagrams so that the table and diagrams combined will provide a systematic procedure for isolating the source of malfunction. Troubleshooting instructions shall be listed and arranged under the following headings:

Troubleshooting Instructions

Trouble	Probable Cause	Isolating Procedure	Remedy
---------	----------------	---------------------	--------

MIL-DTL-87929D**APPENDIX C**

C.3.1.5 Postoperative Procedures WP. Step-by-step instructions for all operations required to restore the test facility to normal configuration after power package testing shall be included. Instructions shall include:

- a. Removal of special equipment from power package and test facility.
- b. Removal of power package from test stand.
- c. References to applicable Technical Manual for engine preservation and de-preservation.
- d. Oil sampling (if applicable).

C.4 DOCUMENT TYPE DEFINITION.

C.4.1 SGML document type definition. The document type definition (DTD) provides the structure and content of documents prepared in accordance with this specification. Data to be delivered digitally in accordance with this Appendix shall be SGML tagged using the DTD applicable to Aircraft Power Package (Engine Installation Hardware Configuration) Testing Procedures Technical Manual.

C.5 DIGITAL SUPPORT SUITE (DSS).

The DSS is comprised of the following tools for authoring and rendering the Basic Work Package Type manual doctype.

C.5.1 DTD. The Aircraft Power Package (Engine Installation Hardware Configuration) Testing Procedures Type DTD provides the structure and content template in accordance with this detail specification. To be delivered digitally, the Aircraft Power Package (Engine Installation Hardware Configuration) Testing Procedures Type manual shall be tagged using the applicable DTD found at the Technical Manual Specifications and Standards (TMSS) activity website (see [A.4.1](#)).

C.5.2 Tag Description Table (TDT). TDT provides detailed descriptions of the elements contained in the Aircraft Power Package (Engine Installation Hardware Configuration) Testing Procedures Type manual DTD. The TDT contains the element tagging structure, full element name, tag minimization requirements, element structure, reference elements, source paragraph, and attribute descriptions unique to the element. See [A.4.1](#) for information on obtaining this file in digital format.

C.5.3 Attribute Description Table (ATD). ATD provides detailed descriptions of the attributes contained in the Aircraft Power Package (Engine Installation Hardware Configuration) Testing Procedures Type manual DTD. See [A.4.1](#) for information on obtaining this file in digital format.

C.6 OBTAINING FILES.

See [A.4](#).

MIL-DTL-87929D**APPENDIX D****SPECIAL REQUIREMENTS FOR STATIC FIRING OF MISSILE MOTORS TECHNICAL MANUAL****D.1 SCOPE.**

D.1.1 Scope. This appendix provides the special or unique criteria, in addition to the provisions of this specification, required for development of a static firing of missile motors Technical Manual (TM). The markup tags described herein are based on rules outlined in MIL-HNDBK-28001 and ISO 8879. The information contained in and referred to in this appendix forms a part of the standard and is intended for compliance. The Document Type Definition (DTD) referenced herein may be obtained directly from the preparing activity (see [A.4.3](#)).

D.2 APPLICABLE DOCUMENTS.

Not applicable.

D.3 SPECIAL REQUIREMENTS.

D.3.1 Static firing of missile motors manua. This manual shall provide procedures for the static firing of missile motors. The manual shall include procedures for transportation of missile motors from the storage facility/Depot Maintenance Facility (DMF) to the test site, roll transfer into and out of the radiographic and other buildings, inspections required throughout the receipt to the test pad area, post firing inspections and dissection. The manual shall also provide procedures for the static firing of the motor, calibration of instrumentation, connection of motor instrumentation to the land lines, data collection, handling, reduction and analysis, and the final report format. The manual shall provide sequentially all operations and procedures required, from the time the rocket motors are removed from, and returned to the operational inventory (DMF)/motor surveillance storage facilities (R&D). The handling inspection, and post firing inspection completion (except static firing) and reduction shall also be included. Also, the instructions shall be prepared in a manner to include two types of motors:

- a. Research and development surveillance.
- b. Operational inventory surveillance.

D.3.1.1 General safety requirements. The following statement shall be included in the safety summary of each WP:

"The safety requirements and precautions set forth in AFI 91-201 shall be complied with by munitions personnel during static firing operations. All personnel engaged directly, as well as indirectly, in operations in which munitions, explosives, and other hazardous materials are involved should be thoroughly trained in explosive safety and capable of recognizing hazardous explosive exposures. Thinking safety and working safely must become a firmly established habit when working with or in the vicinity of items capable of exhibiting a hazard due to the nature of their explosive, flammable, or toxic fillers. The absence of a safety requirement in this manual or in AFMAN 91-201 does not necessarily indicate that no safeguards are needed. A safety precaution is included in procedures where it is required. If immediately dangerous munitions are encountered, all operations in the immediate vicinity shall be shut down, personnel evacuated to a safe location, and EOD or other authorized personnel called to render assistance in elimination of the hazard. Operations shall not be resumed until the hazard has been eliminated."

D.3.1.2 Handling, transportation, and inspection WP. Procedures shall be provided to remove the rocket motor from storage facilities, horizontal/vertical and DMF, and prepare and instrument rocket motor for road test, vibration test, and board course test. These instructions shall also cover the preparation and loading instructions for transportation, including unloading from transporter and all inspection (including nondestructive inspection) required to determine pre-firing posture. The information shall be brief but factual, giving step-by-step procedures.

MIL-DTL-87929D**APPENDIX D**

D.3.1.3 Preparation for firing WP. Procedures shall be provided for preparation and inspection of the motor for static firing, i.e. instrumentation, preparation and installation of Data Acquisition System (DAS). DAS checkout, and installation of firing harness and other related fixtures required for static firing of motor.

D.3.1.4 Prefire facility preparation WP. Procedures shall be provided for test facility preparation (test pad, annex building, data recording building), test equipment verification, test pad instrumentation requirements, digital data reduction information, and test data documentation. In addition, procedures for support systems preparation, rocket motor installation in test stand, and rocket motor alignment in test fixture shall be provided. All procedures necessary for setup, checkout, and inspection of mechanical and electrical systems shall be provided.

D.3.1.5 Test operations and motor firing WP. Procedures shall be provided for motor instrumentation, termination and calibration, Thrust Vector Control System (TVCS) checkout, TVCS dry run performance, pre-fire operations, and motor firing. Emergency procedures for motor hangfire and motor malfunction are required.

D.3.1.6 Postfire inspection WP. Procedures shall be provided for postfire inspections, calibrations, photography, test setup disassembly, test data review and documentation, test anomalies or motor malfunction, dissection of motor and components, and data reduction and analysis.

D.4 DOCUMENT TYPE DEFINITION.

D.4.1 SGML document type definition. The document type definition (DTD) provides the structure and content of documents prepared in accordance with this specification. Data to be delivered digitally in accordance with this Appendix shall be SGML tagged using the DTD applicable to Static Firing of Missile Motors Technical Manual.

D.5 DIGITAL SUPPORT SUITE (DSS).

The DSS is comprised of the following tools for authoring and rendering the Basic Work Package Type manual doctype.

D.5.1 DTD. The Static Firing of Missile Motors Technical Manual Type DTD provides the structure and content template in accordance with this detail specification. To be delivered digitally, the Static Firing of Missile Motors Technical Manual Type manual shall be tagged using the applicable DTD found at the Technical Manual Specifications and Standards (TMSS) activity website (see [A.4.1](#)).

D.5.2 Tag Description Table (TDT). TDT provides detailed descriptions of the elements contained in the Static Firing of Missile Motors Technical Manual Type manual DTD. The TDT contains the element tagging structure, full element name, tag minimization requirements, element structure, reference elements, source paragraph, and attribute descriptions unique to the element. See [A.4.1](#) for information on obtaining this file in digital format.

D.5.3 Attribute Description Table (ATD). ATD provides detailed descriptions of the attributes contained in the Static Firing of Missile Motors Technical Manual Type manual DTD. See [A.4.1](#) for information on obtaining this file in digital format.

D.6 OBTAINING FILES.

See [A.4](#).

MIL-DTL-87929D**APPENDIX E****SPECIAL REQUIREMENTS FOR SYSTEM PECULIAR CORROSION CONTROL TECHNICAL MANUAL****E.1 SCOPE.**

E.1.1 Scope. This appendix provides the special or unique criteria, in addition to the provisions of this specification, required for development of a system peculiar corrosion control Technical Manual (TM). The markup tags described herein are based on rules outlined in MIL-HNDBK-28001 and ISO 8879. The information contained in and referred to in this appendix forms a part of the standard and is intended for compliance. The Document Type Definition (DTD) referenced herein may be obtained directly from the preparing activity (see [A.4.3](#)).

E.1.2 Purpose. This manual provides instructions and guidance to organizational, intermediate, and depot level maintenance personnel for system peculiar corrosion prevention and control on equipment.

E.2 APPLICABLE DOCUMENTS.**E.2.1 Government documents.**

E.2.1.1 Specifications, standards, and handbooks. The following specifications, standards, and handbooks form a part of this document to the extent specified herein. Unless otherwise specified, the issues of these documents are those cited in the solicitation or contract.

STANDARDS**FEDERAL****FED-STD-595**

Color Requirements for Individual Color Chips

E.2.1.2 Other Government documents, drawings, and publications. The following other Government documents, drawings, and publications form a part of this document to the extent specified herein. Unless otherwise specified, the issues are those cited in the solicitation.

PUBLICATIONS**Air Force Technical Manuals****TO 1-1-3**

Inspection and Repair of Aircraft Integral Tanks and Fuel Cells

TO 1-1-8

Application of Organic Coatings, Aerospace Systems

TO 1-1-689-1

Organic/Unit and Intermediate Maintenance - Avionic Cleaning and Corrosion Prevention/Control

1-1-691

Aircraft Weapons Systems - Cleaning and Corrosion Control

(Copies of documents required by contractors in connection with specific procurement functions should be obtained from the acquiring activity or as directed by the contracting officer.)

E.2.2 Non-government standards and other publications. Not applicable.

E.3 SPECIAL REQUIREMENTS.

E.3.1 System Peculiar Corrosion Control Manual. This appendix provides for the general style and format of Corrosion Control Manuals.

E.3.1.1 Preparation. The general preparation of the manual shall be in accordance with [3.4.1](#), [3.4.1.1](#) and the following:

- a. Cleaning and temporary protection WP.
- b. Paint removal and painting WP.
- c. Sealing WP.
- d. Special WPs, if needed.
- e. Corrosion prone areas WPs.

MIL-DTL-87929D**APPENDIX E**

E.3.1.2 Contents. The manual shall contain information required by maintenance personnel for determining the location and extent of corrosion damage and instructions for its removal and treatment. The manual shall not contain information already included in general series TMs unless essential for continuity of system peculiar data. Specific instructions in general series TMs shall be referenced where required. If the information in the general series TMs is not sufficient, the system peculiar manual shall contain the necessary information.

E.3.1.3 New materials. When new materials are used in the original fabrication of the equipment, an alternate material shall be identified for replacements, if available and applicable.

E.3.1.4 Special or proprietary equipment or processes. Use of "special" or proprietary equipment shall not be specified in the TMs without prior approval of the procuring activity and the Air Force Corrosion Program Manager, WR-ALC/CNC. The manual shall not refer to any contractor's process or material specifications. The applicable detailed process instructions shall be specified in the manual if not covered by general series TMs.

E.3.1.5 Cleaning and temporary protection WP. This WP shall describe cleaning and/or washing procedures for the equipment and shall include procedures for use of corrosion preventive compounds for temporary protection of specific areas after washing.

E.3.1.6 Paint removal and painting WP. Procedures which are applicable to the equipment and are not adequately covered in TO 1-1-8. Corrosion removal and treatment procedures shall be included if not sufficiently covered in TO 1-1-691 or TO 1-1-689-1.

E.3.1.7 Sealing WP. This WP shall describe types of sealants to be used. Sealing procedures shall be included and contain references to TO 1-1-691 or TO 1-1-3 where applicable.

E.3.1.8 Special WPs. Special WPs (such as a WP/SWP on the control of microbial infestation in fuel tanks) may be included if a special problem exists, or if the special procedures for inspection and treatment are not covered in the general series TMs.

E.3.1.9 Corrosion prone areas WPs. For aircraft, and larger/medium size missiles and equipment, there shall be a separate WP for each major structural group, auxiliary system or major area. Example: wings, fuselage, empennage, landing gears, and system components. These WPs shall address each corrosion prone area separately and present the following information for each area:

- a. Illustrations shall be used to identify areas and conditions and shall be placed on a page facing the text for each corrosion prone area.
- b. Information covering:
 1. The types of corrosion which may be found in the area and where it is likely to occur.
 2. The cause of the commonly found corrosion in the area.
 3. Particular metal and alloy types in the area.
 4. Any production changes in the equipment which may significantly affect corrosion, including changes in alloys, sealing materials, finishes, etc. Serial numbers of equipment affected by production changes shall be included.
 5. Any other general information about this area.
- c. Information regarding the classification of structure in the area as to what is critical, noncritical, etc. Any necessary warning for critical structure shall be given.
- d. Information giving damage limits or a reference to the manual where the damage limits are located.
- e. Information giving the preferred inspection method, including reference to the Nondestructive Inspection (NDI) manual.
- f. Information giving the recommended treatment/corrosion removal procedures.
- g. Information identifying the type of sealant and sealing methods to be used with suitable reference to other parts of the manual, TOs 1-1-3, 1-1-691, and 1-1-689-1 as required.
- h. Information identifying the finish system to be used and the procedures for application with suitable reference to TOs 1-1-3, 1-1-8, and 1-1-689-1 as required.

MIL-DTL-87929D**APPENDIX E**

E.3.1.10 Illustrations and tables for corrosion prone areas. In addition to the requirements of E.3.1.9, the following illustrations and tables shall be included at the end of every WP/SWP of the manual on corrosion prone areas (e.g. wing, fuselage, etc.).

E.3.1.10.1 Illustrations. An illustration or group of illustrations shall be provided which identify each of these areas/items separately;

- a. Magnesium components.
- b. Critical forgings and/or expensive and difficult to replace components (i.e., primary structure).
- c. High strength steel (over 180 kilopounds per square inch) components.
- d. Areas subject to collect moisture and area drain locations (condensate and urinal drains, battery vents, etc.).

These items/areas must be inspected and protected. An arrow should be included on structural illustrations to show the grain flow. The area of a component which has a tendency to corrode should be highlighted. A location key shall be used to coincide with the text of a corrosion prone area and the table of corrosion inspections specified below.

E.3.1.10.2 Corrosion inspections. A table of corrosion inspections shall provide the following information:

Corrosion Inspections

Index No. ¹	Area/Item Nomenclature	Material Identification	Corrosion Appearance	Preferred Inspection Method	Probably Cause
------------------------	------------------------	-------------------------	----------------------	-----------------------------	----------------

¹ C - Critical area

- a. Index No. This column shall contain an index number corresponding to the key in the illustration and text. The footnote "¹ C - Critical area" shall be included and critical areas shall be identified with a "C" before the index number.
- b. Area/Item Nomenclature. This column shall give the area or part number and nomenclature of the corrosion prone area.
- c. Material Identification. This column shall list the basic metal followed by the standard alloy code in parentheses. When the material has a special surface treatment such as shot peen, stress roll, etc, it shall be specified. Any material change shall be noted.
- d. Corrosion Appearance. This column shall identify the type of corrosion anticipated. A detailed description of what the corrosion will look like on each specific part, based on the use/location/exposure of the part, shall be included in this column or a reference to the discussion of known corrosion problems in the area shall be given. General statements such as "red rust" for steel parts or "white or grey powder" for aluminum parts are not adequate. Specific locations on the part where corrosion may be expected to start shall be identified.
- e. Preferred Inspection Method. This column shall give the preferred inspection method in brief form. Long procedures shall be included in the manual discussion and shall be referenced by the table. NDI procedures shall not be given in detail in the discussion unless they cannot be referenced in another Air Force TM.
- f. Probable Cause. This column shall give the probable cause of the corrosion normally encountered in the area.

E.3.1.10.3 Corrosion removal and repair procedures. A table giving the corrosion removal and repair procedures shall be keyed to the illustrations and text for the corrosion prone areas. The table shall include the following:

MIL-DTL-87929D**APPENDIX E****Corrosion Removal and Repair**

Index No. ¹	Area/Item Nomenclature	Damage Limit	Repair Procedure
------------------------	------------------------	--------------	------------------

¹ C- Critical area

- a. Index No.- See E.3.1.10.2 a.
- b. Area/Item Nomenclature - See E.3.1.10.2 b.
- c. Damage Limit. This column shall provide the damage limits. It shall give specific grind-out limits for each area/item.
- d. Repair Procedure. This column shall specify the corrosion repair procedure or reference a procedure in a general series TM, the text for the corrosion prone area, another WP/SWP or another system peculiar manual. Any material change shall be noted with the procedure for the new material also being listed.

E.3.1.10.4 Sealant repair table. This table shall give the sealant repair procedure for all areas of the equipment with an area/reference key for a specific corrosion prone area, where applicable. Illustrations shall be used if needed. Detailed procedures in TO 1-1-3, TO 1-1-691, or the sealing WP of the manual shall be referenced. The table shall include the following:

Sealant Repair

Index No. ¹	Area/Item Nomenclature	Repair Procedure
------------------------	------------------------	------------------

¹ C- Critical area

- a. Index No. (see E.3.1.10.2a).
- b. Area/Item Nomenclature (see E.3.1.10.2b).
- c. Repair Procedure. This column shall specify the sealant repair procedure or reference a procedure in a general series TM, the text for the corrosion prone area, another WP/SWP or another system peculiar manual. Any material change shall be noted with the procedure for the new material also being listed.

MIL-DTL-87929D**APPENDIX E**

E.3.1.10.5 Finish system table and illustrations. An illustration and a table in each WP/SWP shall show every type coating required for all areas of the equipment covered. The exact areas being defined shall be shown using a silhouette of the structure and a table. The table shall follow the format shown below and shall be keyed to the corresponding silhouette or silhouettes. The area reference key for a specific corrosion prone area shall be used in the table where applicable. Both interior and exterior silhouettes shall be shown. Finish system application procedures in TO 1-1-8, TO 1-1-691, and/or the paint removal and painting WP of the manual shall be referenced in the "Touch-Up Repair and Repaint" column. Vertical and horizontal lines are used in this sample table only for ease of reading.

Finish System

Index No. ¹	Area/Item Nomen- clature	Metal Identifi- cation	Original Pretreat- ment	Color		Touch-Up Repair and Repaint		
				Name	Number FED-STD- 595	Pretreat- ment	Primer	Top Coat

¹ C- Critical area

E.3.1.10.6 Marking illustrations. A table of exterior and interior markings shall show all authorized markings on the equipment. The table shall denote the marking legend, marking/lettering size, color of the marking per FED-STD-595, and exact location by referencing diagrams (foldouts acceptable). These diagrams shall show the actual location and reference back to the marking table. Usable on codes for markings that differ on similar models shall be used.

E.3.2 Definitions.

E.3.2.1 General series technical orders. Technical orders which contain general information applicable to all types of systems. Example; TOs 1-1-3, TO 1-1-691, etc.

E.3.2.2 System peculiar. The term "system peculiar" indicates that information is applicable to one and only one weapon system or other item of aerospace equipment, but all series of a system may be included.

E.3.2.3 Special materials. Special materials are those corrosion control materials not listed in the general series technical orders that are required for use on a particular aerospace system.

E.4 DOCUMENT TYPE DEFINITION

E.4.1 SGML document type definition. The document type definition (DTD) provides the structure and content of documents prepared in accordance with this specification. Data to be delivered digitally in accordance with this specification shall be SGML tagged using the DTD applicable to System Peculiar Corrosion Control Technical Manual.

E.5 DETAILED DESCRIPTION

E.5.1 Document type definition. The DTD provides the structure and content of documents prepared in accordance with this specification. The DTD is available in a digital format. See [A.4.3](#), for information on obtaining the file.

E.5.2 Tag description table. The tag description table (TDT) provides detailed descriptions of the tags and provides the element tagging structure, full element name, tag minimization requirements, element structure, referencing elements, source paragraph, and attribute descriptions unique to the element. See [A.4.3](#), for information on obtaining this table.

MIL-DTL-87929D**APPENDIX F****SPECIAL REQUIREMENTS FOR NONDESTRUCTIVE INSPECTION TECHNICAL MANUAL****F.1 SCOPE.**

F.1.1 Scope. This appendix provides the special or unique criteria, in addition to the provisions of this specification, required for development of a Nondestructive Inspection (NDI) Technical Manual (TM). The markup tags described herein are based on rules outlined in MIL-HNDBK-28001 and ISO 8879. The information contained in and referred to in this appendix forms a part of the standard and is intended for compliance. The Document Type Definition (DTD) referenced herein may be obtained directly from the preparing activity (see [A.4.3](#)).

F.2 APPLICABLE DOCUMENTS.**F.2.1 Government documents.**

F.2.1.1 Specifications, standards and handbooks. The following specifications, standards, and handbooks form a part of this document to the extent specified herein. Unless otherwise specified, the issues of these documents are those cited in the solicitation or contract.

(Copies of these documents are available online at <https://assist.daps.dla.mil/quicksearch/> or from the Standardization Document Order Desk, 700 Robbins Avenue, Building 4D, Philadelphia, PA 19111-5094.)

SPECIFICATIONS**MILITARY****MIL-STD-38784**

Technical Manuals, General Style and Format Requirements

(Unless otherwise indicated, copies of federal and military specifications, standards and handbooks are available from the Standardization Documents Order Desk, Building 4D, 700 Robbins Avenue, Philadelphia, PA 19111-5094.)

F.2.1.2 Other Government documents, drawings, and publications. The following other Government documents, drawings, and publications form a part of this document to the extent specified herein. Unless otherwise specified, the issues are those cited in the solicitation.

PUBLICATIONS**AIR FORCE TECHNICAL MANUALS****TO 33B-1-1**

Nondestructive Inspection Methods

(Copies of documents required by contractors in connection with specific procurement functions should be obtained from the acquiring activity or as directed by the contracting officer.)

F.2.2 Non-government standards and other publications.

F.2.2.1 Non-government publications. The following documents form a part of this document to the extent specified herein. Unless otherwise specified, the issues of these documents are those cited in the solicitation or contract.

NON-GOVERNMENT PUBLICATIONS**INTERNATIONAL ORGANIZATION FOR STANDARDIZATION (ISO)****ISO 8879**

Information Processing - Text and Office Systems - Standard Generalized Markup Language (SGML) (DoD Adopted)

(Application for copies should be addressed to Standardization Documents Order Desk, Building 4D, 700 Robbins Avenue, Philadelphia, PA 19111-5094, for issue to DoD activities. Others may purchase copies from the American National Standards Institute, 11 West 42nd Street, New York, NY 10036.)

MIL-DTL-87929D**APPENDIX F****F.3 SPECIAL REQUIREMENTS.**

F.3.1 Nondestructive inspection (NDI) manual. This manual shall provide all NDI instructions, procedures and techniques for the system, subsystem, components or equipment concerned.

F.3.1.1 Definitions. Definitions of NDI processes, procedures, materials, etc., shall be in accordance with the documents listed in Section F.2 of this appendix.

F.3.1.2 References. The manual shall not include or refer to any contractor's process or material specifications solely by title and number. When such contractor data is needed, this data shall be included in the manual.

F.3.1.3 Commodity items and support equipment. NDI procedures for commodity items and support equipment contained in or on the weapon system shall be included in the system peculiar manual.

F.3.1.4 System peculiar NDI. The manual shall include system peculiar procedures covering the following major NDI methods: fluorescent penetrant, magnetic particle, eddy current, ultrasonic, and radiographic. Other methods shall be included when required to provide improved inspection, capability. The need for inclusion of equipment and reference standards not contained in the Table of Allowances (TA) 455 shall be submitted as soon as the requirement and equipment are identified.

F.3.1.4.1 Routine visual inspections. Routine visual, magnifying glass, or other optical inspections that are normally accomplished by maintenance personnel shall not be included in the manual.

F.3.1.4.2 Instructions. The manual shall contain detailed step-by-step instructions for each inspection so that a qualified NDI technician, can perform the required inspections. The basic theory, practice, and control of NDI methods are contained in TO 33B-1-1 which shall be used as a guide for development of the manual.

F.3.1.4.3 Accept/reject criteria. The manual shall not contain inspection frequency, accept/reject criteria, or instructions for correcting defective conditions. However, the NDI procedures shall be capable of supporting the rejectable flaw sizes listed in the system and/or engine maintenance manuals.

F.3.1.4.4 Related maintenance manuals. The NDI procedures shall be responsive to, and consistent with, the maintenance manuals it supports. Those manuals establish and govern accept/reject criteria, such as rejectable flaw/crack sizes.

F.3.1.5 Illustrations.

F.3.1.5.1 Engineering production drawings. NDI requirements contained in engineering production drawings shall not be automatically used to govern in-service NDI procedures unless specifically approved for maintenance use. Engineering production drawings normally contain requirements generated by fabrication operations and do not necessarily represent NDI requirements generated by the in-service stress spectra.

F.3.1.5.2 Foldout pages and illustrations. Foldout pages shall not be used.

F.3.1.5.3 Specific part/component illustration. Each NDI procedure shall contain an illustration of the specific part or component to be inspected indicating the location and orientation of potential defects. Standard NDI symbols shall be used. The defect location shall be crosshatched or otherwise highlighted on the illustration to indicate the area of the specific NDI procedure.

F.3.1.5.4 Instrumented NDI procedure illustrations. Each instrumented NDI procedure shall contain an illustration which accurately represents equipment readings and other data.

F.3.1.5.5 Illustrations used for more than one inspection. If an illustration is used for more than one inspection of the same component or part, the illustration shall be placed behind the first inspection and referenced in all subsequent inspections.

F.3.1.6 NDI inspection safety. In addition to the requirements of MIL-STD-38784, the safety summary shall specify the requirement to follow the safety precautions outlined in TO 33B-1-1.

F.3.1.7 Sequence. The inspection procedures shall be arranged in a logical sequence of events. The procedures shall contain all information required to perform the NDI method reliably, including references to other technical manuals required to accomplish such tasks as gaining access to a part, removal of protective finishes, referral for accept/reject criteria, etc.

MIL-DTL-87929D**APPENDIX F**

F.3.1.8 NDI equipment technical manuals. NDI equipment technical manuals shall be referenced when they govern initial equipment setup and/or operation.

F.3.1.9 Foreword WP. In addition to the requirements of 3.4.3.2, the foreword WP shall contain the following tables and figures, as applicable, and shall contain the intent of the following:

"This manual contains specific instructions for accomplishing nondestructive inspection of the (insert name) system and its associated subsystems. The procedures provide step-by-step instructions for the nondestructive inspection of locations where service defects would adversely affect safety, reduce fatigue and damage tolerance requirements, prevent items from functioning properly and/or affect component serviceability."

"This manual does not contain inspection level or frequency, accept/reject criteria or instructions for correcting defective conditions. Inspection levels and frequency are provided in the inspection (-6) manual. Detailed accept/reject criteria and instructions for correcting defects are provided in the system maintenance manual set."

"Recommendations for new, revised or field developed procedures shall be prepared on AFTO Form 242, Nondestructive Inspection Data, in accordance with TO 33B-1-1"

F.3.1.9.1 Table of bare aluminum alloy conductivity acceptance values. This table shall indicate alloy type, heat treat (temper), and conductivity in Percent International Annealed Copper Standard (% IACS) for each structural aluminum alloy used in the system.

F.3.1.9.2 Table of clad aluminum alloy sheet conductivity acceptance values. This table shall indicate alloy type, heat treat (temper) and conductivity in % IACS for each structural application.

F.3.1.9.3 Figure of depth of penetration. This figure shall show effective depth of penetration for eddy currents as a function of conductivity of the test material and eddy current operating frequency.

F.3.1.9.4 Figure of exposure correction. This figure shall contain a source to object exposure correction chart for radiographic procedures.

F.3.1.9.5 Figure of radiographs. This figure shall show maximum coverage of radiographs for honeycomb structures as a function of honeycomb thickness against a given cell size for each structural application.

F.3.1.10 Master list of special tools, test equipment, and consumables WP. This WP shall be in accordance with 3.4.3.3 with the following exceptions:

- a. Peculiar NDI equipment shall be listed in a separate table (with same boxhead titles).
- b. Ultrasonic, eddy current, and other NDI reference standards shall be listed in separate tables with a DWG (Drawing) No. column replacing the Figure and Index No. column. The drawing number shall be listed only if it is different from the part number, including dash numbers. Reference to applicable engineering drawings which specify dimensions, surface finish, tolerances, material composition, sample flaws and applicable fasteners of each NDI reference standard shall be included. NDI reference standards, penetrometers, fixtures (such as tube head stands), etc., shall be illustrated in accordance with 3.4.3.4.5.
- c. Eddy current probes shall be listed in a separate table. This list shall denote eddy current probes for each NDI method. (semiautomatic, Manual, Conductivity, etc.)
- d. Ultrasonic transducers shall be listed in a separate table. This list shall denote ultrasonic transducers for each NDI method. (Resonance, Ring Pattern, Contact Through Transmission, etc.)
- e. General NDI equipment shall be listed as follows:

NDI Equipment

Nomenclature	Specification Requirements
--------------	----------------------------

1. Nomenclature. List the generic name of the equipment.
2. Specification Requirements. List the requirements such as amperage, tank size, temperature range, etc., for the system or hardware covered in the NDI manual.

MIL-DTL-87929D**APPENDIX F**

f. Couplants, fluorescent penetrant materials, magnetic particle/magnetic rubber materials, cleaning solvents, etc., are considered consumable items and shall be listed as such.

1. Radiographic materials shall be listed in a separate table.
2. Fluorescent penetrant materials shall be listed in a separate table.
3. Magnetic particle/magnetic rubber materials shall be listed in a separate table.

F.3.1.11 Repetitive NDI procedures WP. This WP shall contain all repetitive (occurring more than once) NDI procedures, including repetitive procedures for NDI equipment setup, and standardization of reference standards. Standard NDI symbols shall be used. The following is a typical WP/SWP breakout; however, regardless of breakout, the information required by the following shall be included.

WP 004	REPETITIVE NDI PROCEDURES (TECHNIQUES)
SWP 01	GENERAL
SWP 02	NDI EQUIPMENT SETUP
SWP 03	FLUORESCENT PENETRANT PROCEDURES
SWP 04	RADIOGRAPHIC PROCEDURES
SWP 05	MAGNETIC PARTICLE PROCEDURES
SWP 06	ULTRASONIC PROCEDURES
SWP 07	EDDY CURRENT PROCEDURES
SWP 08	OTHER NDI PROCEDURES

F.3.1.11.1 SWP 01, General. This SWP shall contain all general information pertinent to WP 004.

F.3.1.11.2 SWP 02, NDI equipment setup. This SWP shall contain all repetitive NDI equipment setups. Steps shall be provided for the standardization of NDI equipment for specific inspections to detect specific defects in a specific structural area or part. Procedures for standardizing instrumented NDI methods using NDI reference standards shall be provided.

F.3.1.11.3 SWP 03, Fluorescent penetrant procedures. This SWP shall contain all repetitive fluorescent penetrant procedures. Visible dye penetrant inspection methods are not acceptable and shall not be included.

F.3.1.11.4 SWP 04, Radiographic procedures. This SWP shall contain all repetitive radiographic procedures. The radiation icon shall be used.

F.3.1.11.5 SWP 05, Magnetic particle procedures. This SWP shall contain all repetitive magnetic particle procedures.

F.3.1.11.6 SWP 06, Ultrasonic procedures. This SWP shall contain all repetitive ultrasonic procedures. The procedure shall state the specific ultrasonic method used (pulse echo, through transmission, etc.).

F.3.1.11.7 SWP 07, Eddy current procedures. This SWP shall contain all repetitive eddy current procedures. The procedure shall state the specific eddy current method used (high frequency, low frequency, etc.).

F.3.1.11.8 SWP 08, Other NDI procedures. This SWP shall contain all other repetitive NDI procedures not provided in SWPs 03 thru 08.

F.3.1.12 WP 005 and subsequent WP/SWPs. WP 005 and subsequent WP/SWPs shall be broken out by major assembly, system, or end item. These WP/SWPs shall contain the NDI procedures for the parts/components within that assembly/system/item. Repetitive procedures shall be referenced as required. A figure of the assembly/system/item shall be provided at the beginning of each WP and the parts/components to be inspected shall be indexed. A table listing the index number, nomenclature, drawing number and inspection figure or paragraph reference for the part/component shall be provided. If the assembly/system/item is so large that indexing of parts or components causes overcrowding, the figure at the beginning of each WP shall consist of the assembly/system/item with subassemblies or subsystems indexed. The figure shall

MIL-DTL-87929D**APPENDIX F**

contain a table listing the subassembly/subsystem index number, nomenclature, and subassembly/subsystem figure reference. The subassembly/subsystem figures shall be located throughout the WP/SWPs preceding the applicable group of part/component inspection procedures.

F.3.1.12.1 Title. The title of each inspection procedure shall consist of the nomenclature of the part/component to be inspected with applicable part numbers.

F.3.1.12.2 Safe for maintenance. Specific safe for maintenance procedures shall be included unless provided in the system manual, in which case they shall be referenced.

F.3.1.12.3 Parts description. Text shall be provided to describe and identify the part/component to be inspected, including part number. The text shall include the specific part material, heat treatment, if applicable, method of fabrication (cast, forged, bonded, etc.), and surface coating/finish.

F.3.1.12.4 Defect description. A narrative with illustration shall be included describing the defect. Illustrations shall be consistent with related manuals.

F.3.1.12.5 Use of NDI standards. NDI reference standards are considered support equipment; however, their specific use shall be governed by the NDI manual.

F.3.1.12.6 General NDI equipment setup procedures. General NDI equipment setup procedures contained in the NDI equipment technical manual shall not be repeated, but shall be referenced.

F.3.1.12.7 Repetitive procedures. All repetitive equipment setup/standardization shall be referenced as required (see [F.3.1.12.2](#)).

F.3.1.12.8 Specific NDI method. The NDI method (fluorescent penetrant, radiographic (x-ray), ultrasonic, etc.) required to evaluate the component, part or area for particular defects, or conditions shall be included. Illustrations shall be used to accurately represent equipment readings and other related data and shall be consistent with related manuals.

F.3.1.12.8.1 Access. This step shall describe the procedures required to gain access for inspection. Examples include: lower flaps, open/close doors, etc. The maintenance manual shall be referenced, to include specific panel numbers for removal, etc.

F.3.1.12.8.2 Preparation of part for inspection. This step shall provide the requirements necessary to prepare the part for inspection, such as: soil removal, removal of protective coatings, primer, topcoat, disassembly, etc. The applicable maintenance manual governing the part preparation requirements shall be referenced.

F.3.1.12.8.3 Equipment required. Equipment required to perform the NDI procedure shall include:

- a. All ground support equipment required to accomplish the specific NDI methods shall be identified.
- b. All NDI equipment required to accomplish the specific NDI methods shall be identified. All NDI equipment required by the NDI manual shall be consistent with NDI equipment model and type used during validation.
- c. NDI reference standards required for standardizing instrumented test sensitivity (ultrasonics, eddy current, etc.) shall be listed, including master standards. A master standard shall be required for functional calibration of instrumented NDI methods, such as eddy current or ultrasonics.

F.3.1.12.8.4 NDI equipment setup/standardization. Steps shall be provided for the setup/standardization of NDI equipment for specific inspections being performed. Procedures for standardizing instrumented NDI methods using NDI reference standards shall be provided.

F.3.1.12.8.5 Supplies. All expendable supplies, items, and/or materials shall be listed as required to perform the specific NDI procedure.

F.3.1.12.8.6 Fluorescent penetrant. Fluorescent penetrant inspections shall conform to [F.3.1.11.3](#).

F.3.1.12.8.7 Radiographic. Radiographic inspection methods shall conform to [F.3.1.11.4](#).

F.3.1.12.8.8 Magnetic particle. Magnetic particle inspections shall conform to [F.3.1.11.5](#).

F.3.1.12.8.9 Ultrasonic. Ultrasonic inspection shall conform to [F.3.1.11.6](#).

F.3.1.12.8.10 Eddy current. Electrical conductivity testing shall conform to [F.3.1.11.7](#).

MIL-DTL-87929D**APPENDIX F**

F.3.1.12.8.11 More than one defect. If more than one defect or type of defect is expected in a component/area, the inspection method to be used for each particular defect shall be included in the NDI procedure.

F.3.1.12.8.12 Additional information. Information pertinent to the inspection procedure which does not fall into any other category shall be included. Example: "This inspection must be performed prior to or following inspection number XX-1."

F.3.1.12.9 Backup NDI procedure (technique). A backup or verification procedure shall be included in all cases where initial inspection results do not provide enough information to be confident a defect is present, or if needed, to quantitatively assess a flaw.

F.3.1.12.10 System securing. The final paragraph in the inspection procedure shall provide information on the securing and/or restoration of the subsystem component, part, or aircraft area in accordance with applicable maintenance manuals. This step is intended to provide only general requirements and shall reference the applicable maintenance manual or procedure number for detailed instructions to restore original operating configuration. For those procedures which require a backup inspection, system securing shall be included in the backup procedure and not the primary.

F.4 DOCUMENT TYPE DEFINITION.

F.4.1 SGML document type definition. The document type definition (DTD) provides the structure and content of documents prepared in accordance with this specification. Data to be delivered digitally in accordance with this specification shall be SGML tagged using the DTD applicable to Nondestructive Inspection Technical Manual.

F.5 DETAILED DESCRIPTION.

F.5.1 Document type definition. The DTD provides the structure and content of documents prepared in accordance with this specification. The DTD is available in a digital format. See [A.4.3](#), for information on obtaining the file.

F.5.2 Tag description table. The tag description table (TDT) provides detailed descriptions of the tags and provides the element tagging structure, full element name, tag minimization requirements, element structure, referencing elements, source paragraph, and attribute descriptions unique to the element. See [A.4.3](#), for information on obtaining this table.

MIL-DTL-87929D**APPENDIX G****SPECIAL REQUIREMENTS FOR AIRCRAFT STRUCTURAL INTEGRITY PROGRAM TECHNICAL MANUAL****G.1 SCOPE.**

G.1.1 Scope. This appendix provides the special or unique criteria, in addition to the provisions of this specification, required for development of an Aircraft Structural Integrity Program Technical Manual (TM). The markup tags described herein are based on rules outlined in MIL-HNDBK-28001 and ISO 8879. The information contained in and referred to in this appendix forms a part of the standard and is intended for compliance. The Document Type Definition (DTD) referenced herein may be obtained directly from the preparing activity (see [A.4.3](#)).

G.2 APPLICABLE DOCUMENTS.**G.2.1 Government documents.**

G.2.1.1 Specifications, standards, and handbooks. The following specifications, standards, and handbooks form a part of this document to the extent specified herein. Unless otherwise specified, the issues of these documents are those cited in the solicitation or contract.

(Copies of these documents are available online at <https://assist.daps.dla.mil/quicksearch/> or from the Standardization Document Order Desk, 700 Robbins Avenue, Building 4D, Philadelphia, PA 19111-5094.)

SPECIFICATIONS**MILITARY****MIL-STD-1530**

Aircraft Structural Integrity Program, Aircraft Requirements

G.2.1.2 Other Government documents, drawings, and publications. The following other Government documents, drawings, and publications form a part of this document to the extent specified herein. Unless otherwise specified, the issues are those cited in the solicitation.

PUBLICATIONS**AIR FORCE INSTRUCTIONS****AFI 63-1001**

Aircraft Structural Integrity Program

(Copies of documents required by contractors in connection with specific procurement functions should be obtained from the acquiring activity or as directed by the contracting officer.)

G.2.2 Non-government standards and other publications.

G.2.2.1 Non-government publications. The following documents form a part of this document to the extent specified herein. Unless otherwise specified, the issues of these documents are those cited in the solicitation or contract.

NON-GOVERNMENT PUBLICATIONS**INTERNATIONAL ORGANIZATION FOR STANDARDIZATION (ISO)****ISO 8879**

Information Processing - Text and Office Systems - Standard Generalized Markup Language (SGML) (DoD Adopted)

(Application for copies should be addressed to Standardization Documents Order Desk, Building 4D, 700 Robbins Avenue, Philadelphia, PA 19111-5094, for issue to DoD activities. Others may purchase copies from the American National Standards Institute, 11 West 42nd Street, New York, NY 10036.)

G.3 SPECIAL REQUIREMENTS.

G.3.1 Aircraft Structural Integrity Program (ASIP) manual. This manual directs special aircraft related maintenance procedures required to support an ASIP. Coverage shall provide instructions and guidance to crew members and to personnel in the organizational, intermediate, and depot levels of maintenance. An explanation of the ASIP for the particular series of aircraft shall be included.

MIL-DTL-87929D**APPENDIX G**

G.3.1.1 Preparation. The general manner of preparation shall be in accordance with 3.4.1 and 3.4.1.1, except the manual shall not contain a master list of special tools, test equipment, and consumables WP. In addition to the requirements of 3.4.1 and 3.4.1.1, the following shall be included:

- a. ASIP General Description (part of Foreword)
- b. (Aircraft designation) ASIP Description
- c. (Aircraft designation) Aircraft Program Operation

G.3.1.2 Foreword WP. In addition to the requirements of 3.4.3.2, the foreword WP shall contain descriptive information about the ASIP in general. It shall include the following:

G.3.1.2.1 Program objectives. A discussion of AFI 63-1001 as it relates to this manual shall be included.

G.3.1.2.2 Tasks. A brief description of Task I through Task III as described in MIL-STD-1530 and a more detailed description of Tasks IV and V of the Force Management Program shall be included.

G.3.1.2.3 Interaction with other programs. Information describing the integral part the operational aircraft programs play in the overall ASIP shall be included.

G.3.1.2.4 Applicable references. A list of all references required to support the Flight Recorder and Individual Airplane Tracking (IAT) programs shall be included. These references include: applicable handbooks, specifications, standards, TMs, regulations, instructions, and work unit codes. This list shall be part of the list of related publications.

G.3.1.3 (Aircraft designation) ASIP description. This WP shall contain descriptive information about the specific aircraft ASIP. It shall include the following:

- a. A general description of the applicable force management (Task V) Operational Programs for the aircraft. The Flight Loads Recorder Program shall be listed and described as an integral part of the Loads/Environment Spectra Survey Program. The following operational programs shall be listed and described as an integral part of the IAT Data Program:
 1. Exceedance Counter Program.
 2. Mechanical Strain Recorder Program.
 3. IAT Forms Program (to include AFTO Form 238 for component serialization report).
- b. Graphical flow diagrams of flight loads recorder data through the Loads/Environment Spectra Survey Program and exceedance counter, mechanical strain recorder and IAT data through the IAT Program. Further, flow diagrams shall show the information feedback to organizational, intermediate, and depot levels of maintenance. A brief discussion of each task/step in the graphical flow diagram shall also be included.
- c. Detailed instructions for recorder or forms management reporting/information collection responsibilities. Single points of contact for each functional/management area shall also be included.

G.3.1.4 (Aircraft designation) aircraft program operation. Unless otherwise specified by the acquiring activity, this WP shall contain reference to existing aircraft TMs. When specified, detailed system description, operation, checkout, maintenance, troubleshooting, and data forms instructions for the following flight data gathering programs (if applicable to aircraft series) shall be included:

- a. Flight Loads Recorder Program.
- b. Exceedance Counter Program.
- c. Mechanical Strain Recorder Program.
- d. IAT Forms Program.

G.4 DOCUMENT TYPE DEFINITION

G.4.1 SGML document type definition. The document type definition (DTD) provides the structure and content of documents prepared in accordance with this specification. Data to be delivered digitally in

MIL-DTL-87929D

APPENDIX G

accordance with this specification shall be SGML tagged using the DTD applicable to Aircraft Structural Integrity Program Technical Manual.

G.5 DETAILED DESCRIPTION

G.5.1 Document type definition. The DTD provides the structure and content of documents prepared in accordance with this specification. The DTD is available in a digital format. See [A.4.3](#), for information on obtaining the file.

G.5.2 Tag description table. The tag description table (TDT) provides detailed descriptions of the tags and provides the element tagging structure, full element name, tag minimization requirements, element structure, referencing elements, source paragraph, and attribute descriptions unique to the element. See [A.4.3](#), for information on obtaining this table.

MIL-DTL-87929D**APPENDIX H****SPECIAL REQUIREMENTS FOR ATE OPERATOR TEST PROCEDURES TECHNICAL MANUAL****H.1 SCOPE.**

H.1.1 Scope. This appendix provides the special or unique criteria, in addition to the provisions of this specification, required for development of an Automated Test Equipment (ATE) Operators Test Procedures Technical Manual (TM). The markup tags described herein are based on rules outlined in MIL-HNDBK-28001 and ISO 8879. The information contained in and referred to in this appendix forms a part of the standard and is intended for compliance. The Document Type Definition (DTD) referenced herein may be obtained directly from the preparing activity (see [A.4.3](#)).

H.2 APPLICABLE DOCUMENTS.

H.2.1 Government documents. Not Applicable.

H.2.2 Non-government standards and other publications.

H.2.2.1 Non-government publications. The following documents form a part of this document to the extent specified herein. Unless otherwise specified, the issues of these documents are those cited in the solicitation or contract.

NON-GOVERNMENT PUBLICATIONS

INTERNATIONAL ORGANIZATION FOR STANDARDIZATION (ISO)

ISO 8879

Information Processing - Text and Office Systems - Standard
Generalized Markup Language (SGML) (DoD Adopted)

(Application for copies should be addressed to Standardization Documents Order Desk, Building 4D, 700 Robbins Avenue, Philadelphia, PA 19111-5094, for issue to DoD activities. Others may purchase copies from the American National Standards Institute, 11 West 42nd Street, New York, NY 10036.)

H.3 SPECIAL REQUIREMENTS.

H.3.1 ATE operator test procedures manual. Operator test procedures manuals are used in conjunction with ATE. Manuals prepared to this specification must be compatible with the approved maintenance concept and related documents such as computer program source listing, flow charts and test requirements documents. The manual shall contain specific procedures for using one or more Computer Programs (CP) with ATE to test, fault isolate, or calibrate one or more Units Under Test (UUT).

H.3.1.1 Foreword WP. In addition to the requirements of [3.4.3.2](#), the following information shall be included.

H.3.1.1.1 Purpose. The intended function of the manual shall be described relative to the test equipment type, unit(s) to be tested and applicable level of maintenance. These items shall be described by nomenclature, type designation, reference designation, and part number, referring to the Table of Use and Applicability.

MIL-DTL-87929D**APPENDIX H**

H.3.1.1.2 Table of use and applicability. This table shall specify in matrix form the following information as a minimum:

Table of Use and Applicability

UUT	ATE	ITA	CPIN (The applicable CPIN revision number(s) and date are identified in the compendium)	Test Time
-----	-----	-----	---	-----------

- a. UUT. Part number and unique reference designation number (if assigned) of each configuration of UUT which is supported by the manual. Identification shall be by brief nomenclature when part number and reference designator cannot be determined.
- b. ATE. Part number and unique reference designation number of ATEs used to test each UUT.
- c. ITA. Part number and unique reference designation number of Interface Test Adapter(s) (ITA) required to test each UUT.
- d. CPIN. Identification of computer program(s) configuration(s) by Computer Program Identification Number (CPIN) which is required to test each UUT. The applicable computer program revision number(s) required can be identified in the compendium. When multiple program storage media is used, the applicable call number(s) required to access each CP shall also be provided. The CPIN revision and date shall not be included in the manual.
- e. Test Time. Test time for each UUT.

H.3.1.1.3 Table for station utilization. This table shall specify in matrix form the minimum information necessary for the station operator to know what station components are required to be operational/installed to test each specific UUT.

H.3.1.1.4 Additional reference material. Engineering data, such as specifications and drawings, shall not be listed unless the information is essential to the use of the manual and inclusion is approved by the acquiring activity. This information shall be part of the list of related publications.

H.3.1.1.5 Capabilities and limitations. The capabilities and limitations relative to test performance shall be specified in terms of the total test setup (ATE, UUT, ITA, CP, C&S, and ancillary equipment). When applicable, temperature, relative humidity, barometric pressure and other environmental factors which could affect testing shall be expressed in terms which apply to any testing configuration listed in the Table of Use and Applicability.

H.3.1.1.6 Operator participation. Conditions which will require participation by the operator during the testing process shall be fully described. This information shall be limited to description of circumstances which may occur and type of action to be taken. Instructions relative to specific programmed tests shall not be repeated here (see H.3.1.3.2.2).

H.3.1.2 Master list of special tools, test equipment, computer software, and consumables WP. In addition to the requirements of 3.4.3.3, the following shall be included.

H.3.1.2.1 Computer software. Descriptions of technical manual references to all associated software used with the ATE for checkout of the UUT shall be included. Each software product shall be identified by its associated CPIN. The appropriate CPIN references shall, as a minimum, include references as follows:

- a. For the UUT test software.
- b. For the ATE operating system (and/or executive control testing).
- c. For the ATE self-test software (for ATE confidence testing).

MIL-DTL-87929D**APPENDIX H**

- d. For the UUT interface test adapter self-test software (for active circuitry operational assurance).
- e. For the ATE support software (for on-line utilities such as editors, compilers, debuggers, and media transfer).

H.3.1.3 Test procedures WP. Complete information shall be provided which will enable an operator to evaluate the performance of a UUT and diagnose the cause(s) of any malfunction(s) encountered. All references to the UUT, ATE, and ITA(s) shall be exclusively by nomenclature or reference designation number, or both. References to the CPs or to related publications shall not include change, revision, or date. Information which is communicated to the operator by means of visual display shall not be repeated in this WP except to the extent required for explanation of the meaning. This WP may be broken down into SWPs to accommodate inclusion of two or more test procedures.

H.3.1.3.1 Preparation for testing. Complete step-by-step instructions shall be provided to effect all UUT, ITA, ATE interconnections (electronic and mechanical), physical positioning, switch/control settings, CP loading, and any other actions required to establish the correct testing configuration for performing the programmed test procedures. ATE confidence testing, visual inspection of the UUT, safe-to-turn-on tests, and other pretest checks shall be performed prior to connecting the UUT to ATE.

H.3.1.3.1.1 Test setup diagrams. Test setup diagrams shall be used to supplement the preparation for testing text. The number of diagrams shall be kept to the minimum required, consistent with the configurations contained in the Table of Use and Applicability. Interconnection detail shall be limited to the extent required for clarity. Wiring or circuitry internal to cables or equipment, pin numbers within connectors, or similar information which is not critical to ensure a correct testing configuration shall not be included. Test setup diagrams shall depict connections for ducting, heat sinking, etc., when they form a part of the test setup.

H.3.1.3.2 Testing procedures. Procedures, in the proper sequence for conducting a complete end-to-end test of a UUT as programmed in the appropriate CP, shall be provided. Sufficient information shall be included to enable the operator to: start testing, intervene when required to perform manual operations, interpret automated or manual test results, identify cause(s) of malfunction(s), perform normal and emergency shutdown procedures, and to restart testing subsequent to intervention or shutdown. Instructions shall be provided to accomplish any manual testing that forms a part of the complete testing procedures. All necessary safety precautions shall be included.

H.3.1.3.2.1 Test start. These procedures shall instruct the operator in the proper method of starting UUT testing under CP control. When this information is contained in the applicable ATE manual(s), reference shall be made that familiarization with the procedures contained therein is required. That information shall be repeated in this manual only to the extent required to enable an operator, trained in the use of the applicable tester, to start testing.

H.3.1.3.2.2 Operator intervention. When required to augment visual displays under program control and the information contained in Operator Participation (see [H.3.1.1.6](#)), specific instructions shall be provided for performance of manual procedures. These instructions shall reference the applicable test indication numbers(s) and visual display data. Sufficient information shall be provided to enable the operator to determine required actions, make necessary calculations and decisions, perform manual operations, and return testing to program control or terminate testing, as applicable.

H.3.1.3.2.3 Interpretation of test results. In addition to the operator intervention instructions, information shall be provided which clearly explains test results. This information shall reference the applicable test indication number(s) and visual display data.

H.3.1.3.2.4 Malfunction isolation. When isolation of malfunction causes(s) cannot be accomplished to the appropriate level under CP control, procedures for manual or manually assisted isolation shall be provided. These procedures shall meet the criteria of [H.3.1.3.2.2](#).

H.3.1.3.2.5 Termination and restart. These procedures shall instruct the operator in the proper method(s) to terminate testing under both routine and emergency conditions and to reestablish testing under CP control. When this information is contained in the applicable ATE manual(s), reference shall be made that familiarization with the procedures contained therein is required. That information shall be repeated

MIL-DTL-87929D

APPENDIX H

in this manual only to the extent required to enable an operator, trained in the use of the applicable ATE, to terminate and restart testing.

H.3.1.3.2.6 Test points. When testing and fault isolation procedures require manual probing of test points on the UUT, sufficient information in the form of text and illustrations to permit ready identification of each test point shall be provided. All necessary safety precautions shall be included.

H.3.1.3.2.7 Fault isolation loops. Fault isolation loops shall be provided for each functional testing area of UUTs. Loops shall provide sufficient information to allow an operator to identify the cause of any malfunction, be it the UUT, interconnecting adapters/ cables, or the ATE.

H.3.2 Definitions.

H.3.2.1 Diagnostic Flow Chart (DFC). Provides the detailed UUT oriented methods employed on a test-by-test basis showing all branching and including the purpose, methodology, and expected results.

H.3.2.2 Test Diagrams (TDM). Provides the detailed the UUT, ITA, and ATE interface information on a test-by- test basis. There are two types of diagrams that are applicable; a system diagram and TDM.

H.4 DOCUMENT TYPE DEFINITION.

H.4.1 SGML document type definition. The document type definition (DTD) provides the structure and content of documents prepared in accordance with this specification. Data to be delivered digitally in accordance with this specification shall be SGML tagged using the DTD applicable to ATE Operator Test Procedures Technical Manual.

H.5 DETAILED DESCRIPTION

H.5.1 Document type definition. The DTD provides the structure and content of documents prepared in accordance with this specification. The DTD is available in a digital format. See [A.4.3](#) for information on obtaining the file.

H.5.2 Tag description table. The tag description table (TDT) provides detailed descriptions of the tags and provides the element tagging structure, full element name, tag minimization requirements, element structure, referencing elements, source paragraph, and attribute descriptions unique to the element. See [A.4.3](#), for information on obtaining this table.

MIL-DTL-87929D**APPENDIX I****SPECIALIZED STORAGE AND MAINTENANCE PROCEDURES; AUR MUNITIONS AND ASSOCIATED SUPPORT EQUIPMENT, CONVENTIONAL COMPONENTS, AND CMBR AGENTS TECHNICAL MANUAL****I.1 SCOPE.**

I.1.1 Scope. This appendix provides the special or unique criteria, in addition to the provisions of MIL-DTL-87929, required for development of the following: Specialized Storage and Maintenance Procedures for All Up Round (AUR) Munitions (missiles, precision guided, and assembled munitions and associated support equipment), Conventional Components and Chemical Munitions/Biological Research (CMBR) Agents Technical Manual (TM). The markup tags described herein are based on rules outlined in MIL-HNDBK-28001 and ISO 8879. The information contained in and referred to in this appendix forms a part of the standard and is intended for compliance. The Document Type Definition (DTD) referenced herein may be obtained directly from the preparing activity (see A.4.3). The information contained herein is intended for compliance.

I.2 APPLICABLE DOCUMENTS.**I.2.1 Government documents.**

I.2.1.1 Specifications, standards and handbooks. The following specifications, standards, and handbooks form a part of this document to the extent specified herein. Unless otherwise specified, the issues of these documents are those cited in the solicitation or contract.

SPECIFICATIONS**MILITARY**

MIL-PRF-38807 Manuals, Technical - Illustrated Parts Breakdown, Preparation of

STANDARDS**MILITARY**

MIL-STD-38784 Technical Manuals - General Style and Format Requirements

FEDERAL

FED-STD-595 Color Requirements for Individual Color Chips
DoD Manual 6055.09-M DoD Ammunition and Explosive Safety Standards

(Copies of these documents are available online at <https://assist.daps.dla.mil/quicksearch/> or from the Standardization Document Order Desk, 700 Robbins Avenue, Building 4D, Philadelphia, PA 19111-5094.)

I.2.1.2 Other Government documents, drawings, and publications. The following other Government documents, drawings, and publications form a part of this document to the extent specified herein. Unless otherwise specified, the issues are those cited in the solicitation.

PUBLICATIONS**AIR FORCE TECHNICAL MANUALS**

TO XX-XXX-06 Applicable Work Unit Code Manual (WUC) (when required)
TO 1-1-691 Aircraft Weapon Systems-Cleaning and Corrosion Control
TO 11A-1-10 General Instructions, Munitions Serviceability Procedures

Air Force Instructions

AFI 21-201 Conventional Munitions Maintenance Management
AFI 21-202 Spacelift Maintenance and Mission Assurance
AFI 91-204 Safety Investigation and Reports

Air Force Manuals

AFMAN 91-201 Explosives Safety Standards

MIL-DTL-87929D**APPENDIX I**

(Copies of documents required by contractors in connection with specific procurement functions should be obtained from the acquiring activity or as directed by the contracting officer.)

I.2.2 Non-government standards and other publications.

I.2.2.1 Non-government publications. The following documents form a part of this document to the extent specified herein. Unless otherwise specified, the issues of these documents are those cited in the solicitation or contract.

NON-GOVERNMENT PUBLICATIONS

INTERNATIONAL ORGANIZATION FOR STANDARDIZATION (ISO)

ISO 8879

Information Processing - Text and Office Systems - Standard
Generalized Markup Language (SGML) (DoD Adopted)

(Application for copies should be addressed to Standardization Documents Order Desk, Building 4D, 700 Robbins Avenue, Philadelphia, PA 19111-5094, for issue to DoD activities. Others may purchase copies from the American National Standards Institute, 11 West 42nd Street, New York, NY 10036.)

I.3 REQUIREMENTS.

I.3.1 Specialized storage and maintenance procedures; AUR munitions and associated support equipment, conventional components, and CMBR agents. This appendix covers the requirements for specialized inspection, testing, maintenance, and storage procedures to be accomplished during the life-cycle of AUR munitions/support equipment/conventional components, and CMBR agents and associated containers. The manuals shall include all procedures necessary to establish a complete progressive storage and maintenance program. No requirement shall be omitted, even if the requirement would not be applicable until expiration of a long interval of storage. Specific requirements that are not applicable to the weapon system may be omitted unless otherwise specified herein. Work described shall be limited to that which is accomplished in the designated storage, inspection, and maintenance areas. Operation and maintenance instructions for auxiliary equipment shall not be included; applicable manuals shall be referenced.

I.3.2 General Work Package (WP)/Subordinate Work Package (SWP) requirements. The general manner of preparation shall be in accordance with MIL-DTL-87929 with the following exceptions.

- a. Paragraphs shall be numbered in accordance with MIL-STD-38784.
- b. Table of contents shall be arranged alphabetically and shall only list primary and first subordinate paragraphs. If the acquiring activity requires, second subordinate paragraphs may be added (see 6.2.j.8.(a)).
- c. When applicable, the following statement shall be included on the WP/SWPs title page: "THIS (WORK PACKAGE/SUBORDINATE WORK PACKAGE) INCOMPLETE WITHOUT WORK PACKAGE WP 020 00." This statement shall be located two lines below the title block.
- d. The requirements of MIL-DTL-87929 3.4.1.1b. and 3.4.3.1a. (5) do not apply.
- e. The requirements of MIL-DTL-87929, 3.4.3.6h., 3.4.3.6j., and 3.4.3.6k. do not apply.
- f. A safety summary shall be located in each WP/SWP except, WP 010 00, WP 020 00, WP 030 00, and WP 998 00. This paragraph shall be titled Safety Summary and Accident Prevention, and contain the following statement: "All personnel involved in the performance of the procedures in this WP/SWP shall be thoroughly familiar with the safety and accident prevention information contained in WP 020 00."
- g. The consumable materials list within each WP/SWP shall be in accordance with MIL-DTL-87929, 3.4.3.4.3, except the "CAGE" column shall be titled "Use" and shall give the use of the item within the WP/SWP.
- h. The applicable support equipment list shall be in accordance with MIL-DTL-87929, 3.4.3.4.4, except: the table shall be titled "Tools and Equipment"; the "Part Number" column shall be titled "Part/Specification Number" and shall list the applicable part or specification number; and the "CAGE" column shall be titled "Use" and shall give the use of the item within the WP/SWP.

MIL-DTL-87929D**APPENDIX I**

1. WP 010 00 Foreword/System Description (see [I.3.5.1](#)).
2. WP 020 00 Safety Summary and Accident Prevention (see [I.3.5.2](#)).
3. WP 030 00 Master Lists of Special Tools, Equipment, and Consumables (see [I.3.5.3](#)).
4. WP 040 00 Storage and Handling Requirements (see [I.3.5.4](#)).
5. WP 050 00 Inspection Requirements and Procedures (see [I.3.5.5](#)).
6. WP 060 00 Unpacking and Packaging (see [I.3.5.6](#)).
7. WP 070 00 Maintenance (see [I.3.5.7](#)).
8. WP 998 00 Illustrated Parts Breakdown (see [I.3.5.8](#)).

b. When used, the following WPs shall be numbered and titled as follows:

1. WP 080 00 Testing/Reprogramming (see [I.3.5.9](#)).
2. WP 090 00 Contingency Procedures (see [I.3.5.10](#)).
3. WP 100 00 Depot Related Data and Special Instructions (see [I.3.5.11](#)).
4. WP 110 00 - WP 997 00 Any other WP as specified by acquiring activity (see [I.3.5.12](#), [I.6.1](#)).

I.3.5.1 Foreword/System Description WP (WP 010 00). The Foreword/System Description WP will always be the first WP and the requirements of MIL-DTL-87929, [3.4.3.2](#), apply, with the following exceptions:

- a. The requirements of MIL-DTL-87929, [3.4.3.2 \(a\)](#), [\(b\)](#), and [\(c\)](#) do not apply.
- b. The requirements of MIL-DTL-87929, [3.4.3.2 \(d\)](#), except for the hazardous materials icon requirements of MIL-STD-38784 which shall be included in the Safety Summary and Accident Prevention WP. Only non-USAF standard abbreviations/acronyms need be explained.
- c. In addition, the following shall be included:

I.3.5.1.1 Description of item. A physical and functional description of the item and each component shall be included. When applicable, a detailed theory of operation shall also be included. Appropriate illustrations shall be included.

I.3.5.1.2 Table of leading characteristics. Table of leading characteristics. A table of leading characteristics shall be provided in landscape orientation. The table shall list the nomenclature, FSC/DODIC (Department of Defense Identification Code), Part No./Model No./CAGE, length, width, diameter, center of gravity, weight, net explosive weight (NEW), and Dimensions Outer Pack for the item and each component, as applicable.

Table of Leading Characteristics

Nomenclature	FSC/DODIC	Part/Model No./CAGE Code	Dimensions (Inches)				Center of Gravity	Weight (Pounds)		Dimensions (Inches) Outer Pack
			Length	Width	Height	Diameter		Gross	NEW	

I.3.5.1.3 Markings. The physical description illustration(s) shall be used to show markings. Color coding requirements shall be included in textual form. Color graphics shall not be used to illustrate color coding requirements. Item and container markings shall be included as applicable.

I.3.5.1.4 Configuration Table. A configuration table shall be included in landscape format. As a minimum, the table shall list configuration(s)/components by nomenclature and part number. The acquiring activity will provide additional column headings as required (see [I.6.2](#)).

I.3.5.2 Safety Summary and Accident Prevention WP (WP 020 00). In addition to the safety summary requirements of MIL-STD-38784, this WP shall contain information pertaining to accident prevention and shall also contain a description of the following hazards: explosive; pneumatic; electrical (high voltage); chemical; static electricity; environmental; other associated hazards. The following paragraph shall be included:

MIL-DTL-87929D**APPENDIX I**

"When an abnormal condition is noted and procedures are not available in this manual, work shall be stopped and qualified guidance obtained. Personnel shall be evacuated to a safe site. Explosive Ordnance Disposal (EOD) or other authorized personnel shall be called for help in eliminating the hazard. Operations shall not be resumed until the hazard has been eliminated."

Additionally, WARNINGS and CAUTIONS associated with normal operations or routine procedures shall be covered in this WP.

I.3.5.2.1 Hazardous materials. In addition to the requirements of MIL-STD-38784, the following data shall be provided:

- a. A list of all hazardous materials required by maintenance procedures contained in the manual.
- b. For each hazardous material, the list shall illustrate the appropriate icon, state the specific hazard, describe the application of the material (including accident prevention requirements), and state appropriate disposal procedures.
- c. Hazardous materials, when applicable, may be combined into groups when their hazards, application, and disposal data are compatible. However, sequence numbers shall not be grouped.
- d. In this manual the caption WARNING shall not be used for hazardous material. Instead, icons shall be used to alert personnel that the procedures to be performed require the use of such products. Under this icon, the name of the hazardous material and a numeric identifier shall be given. The hazardous material icon shall only appear prior to the procedure (immediately preceding the first step) in which the material will be used.

I.3.5.2.2 Accidents/Incidents. This paragraph shall state the following:

"Accidents/incidents involving collision or inadvertent release of the (insert applicable item) can cause the (insert applicable item) to misfire, malfunction, or explode. If any doubt exists as to acceptability of the (insert applicable item), reject it. Report accident/incident and notify appropriate authority if explosive components are involved."

I.3.5.2.3 Dropped munitions/component processing. This paragraph shall present the reporting and disposition of munitions/components that have been dropped, and refer to a table which provides specific processing/inspection criteria. This paragraph shall state the following:

"Dropped munitions/component processing criteria are contained in the following table. If any doubt exists as to acceptability of dropped component/AUR, reject it. Report dropping incidents in accordance with AFI 91-204, and notify appropriate authority if explosive components are involved. Request disposition of dropped components from (insert appropriate Air Logistics Center [ALC])."

I.3.5.2.4 Drop criteria. When applicable, component drop criteria shall be included in the following format:

Drop Criteria

Item	Packaged/ Unpackaged	Drop Distance (ft.)	Required Action
------	----------------------	---------------------	-----------------

I.3.5.2.5 Fire. A paragraph shall be included for explosive components enveloped by fire. Information shall include withdrawal times and distance, and fire fighting guidance. A reference to TO 11A-1-46 and AFMAN 91-201 shall also be included.

I.3.5.2.6 Danger zones. When applicable, an illustration showing danger zones shall be provided.

I.3.5.3 Master Lists of Special Tools Equipment, and Consumables WP (WP 030 00). This WP shall contain the information required by MIL-DTL-87929, 3.4.3.3, except as noted herein.

I.3.5.3.1 Improper use of tools. The following warning shall precede the master list of special tools:

WARNING

Improper use of tools and equipment can cause injury to personnel.

MIL-DTL-87929D**APPENDIX I**

I.3.5.3.2 Common tools. The following paragraph shall be included:

"A substitute item may be used in place of any common tool if the use does not degrade the condition and reliability of the material or safety of operation."

I.3.5.3.3 Electrical and pneumatic power requirements. Electrical and pneumatic power requirements for special tools, test equipment, and support equipment shall be given. As a minimum, voltage, type, frequency, and tolerance shall be stated for electrical requirements, and operating pressure/vacuum and flow demand for pneumatic requirements.

I.3.5.3.4 Master list of special tools. The list of special tools shall be in accordance with MIL-DTL-87929, 3.4.3.3.1, with the following exceptions. The Part No. column shall be titled "Part/Specification No." and the part or specification number, as applicable, shall be included. Alternate items shall be listed immediately following the item for which it is an alternate. Alternate items shall be identified as alternate in the use column. Unless otherwise specified, special tools shall be illustrated in this WP (see I.6.2).

I.3.5.3.5 Master list of test equipment. The list of test equipment shall be in accordance with MIL-DTL-87929, 3.4.3.3.2 except the "Type Designation" column shall be titled "Part No." and the part number shall be used. Unless otherwise specified, test equipment shall be illustrated in this WP (see I.6.1).

I.3.5.3.6 Master list of support equipment. The list of support equipment shall be arranged in the following format. If an alternate item of support equipment can be used, it shall be listed immediately following the item for which it is an alternate, and be identified as an alternate in the Use column. When specified, support equipment shall be illustrated in this WP (see I.6.1).

Master List of Support Equipment

Part No. / NSN	CAGE Code	Figure Number	Nomenclature	Use
----------------	-----------	---------------	--------------	-----

- a. Part No./NSN. Support equipment shall be listed in alphanumeric sequence by part number or National Stock Number; except alternate items shall be listed immediately following the item for which it is an alternate.
- b. CAGE Code. The CAGE code or manufacturers name and address if code is not available.
- c. Figure Number. The figure number in this WP which illustrates the item. If the item is not illustrated, the statement "Not Illustrated" shall appear in this column.
- d. Nomenclature. Nomenclature shall be in accordance with the requirements of MIL-PRF-38784.
- e. Use. A brief statement indicating the use of the item shall be provided in this column.

I.3.5.3.7 Master list of safety and protective devices. The list of safety and protective devices shall follow the list of support equipment and shall be arranged as follows (requirements for each column are the same as I.3.5.3.6a. through I.3.5.3.6e.):

Master List of Safety and Protective Devices

Part No. / NSN	CAGE Code	Figure Number	Nomenclature	Use
----------------	-----------	---------------	--------------	-----

I.3.5.3.8 Master list of consumables. The list of consumables shall be in accordance with MIL-DTL-87929 (see 3.4.3.3.3).

I.3.5.4 Storage and Handling Requirements WP (WP 040 00).

MIL-DTL-87929D**APPENDIX I**

I.3.5.4.1 Specialized Storage and Handling. Principal hazards involved in the storage and handling of items and explosive components listed in the manual shall be included. A reference to AFMAN 91-201 for definition of terms shall be included. A reference to TO 11A-1-46, AFMAN 91-201, and DoD Manual 6055.09-M for storage, handling, and compatibility requirements shall be included. An identification paragraph shall be included to read: "The use of standard nomenclature and lot number/serial number is mandatory for all storage records, reports, and communications concerning munitions. Legible identification markings shall be maintained on munitions in storage." Specialized storage and handling procedures shall be arranged in the following order:

- a. Handling
- b. Storage Data
- c. Storage Requirements

I.3.5.4.1.1 Handling. When required, instructions shall include normal and specialized handling procedures. A warning pertaining to careful handling of explosive material shall be included. The following statement shall be included: "Damaged containers shall be repaired as soon as possible and markings restored to the repaired area. Chemical protection equipment required when handling items covered by the manual shall be in accordance with AFMAN 91-201."

I.3.5.4.1.2 Storage data. A storage data table shall be included and contain the following information in the format shown. Special shelf/service life requirements shall be identified by notes.

Storage Data

Item	Temperature Limitations (°F or °C)		Shelf Life	Service Life
	Min	Max		

- a. Item. List all munitions/components (nomenclature, type, model, and part number).
- b. Temperature Limitations (if applicable). Provide the minimum and maximum temperature limits for the item.
- c. Shelf Life/Service Life. Provide the shelf and service life of the item in years, months or days, as applicable.

I.3.5.4.1.3 Storage requirements. Data shall cover general storage requirements, serviceability statements, and requirements pertaining to both inside and outside storage. Stacking limitations and dunnage requirements shall be included.

I.3.5.5 Inspection Requirements and Procedures WP (WP 050 00). When required, inspection requirements shall cover the end item, and all components listed which are packaged and stored separately. Inspection requirements for training, dummy/inert and nonexplosive items shall be listed, as applicable. General guidelines for inspections and definitions of terms are contained in TO 11A-1-10 and shall be used as reference in preparing specific requirements. Inspection requirements shall be in the following order. When a requirement is not applicable, it shall be included and marked "Not Applicable."

- a. Types of Inspections (see I.3.5.5.1.1).
 1. Receiving Inspection (see I.3.5.5.1.1)
 2. Shipping Inspection (see I.3.5.5.1.2)
 3. Periodic Inspection (see I.3.5.5.1.3)
 4. Special Inspection (see I.3.5.5.1.4)
 5. Pre-issue Inspection (see I.3.5.5.1.5)
 6. Returned Munitions Inspection (see I.3.5.5.1.6)
 7. Storage Monitoring Inspection (see I.3.5.5.1.7)

MIL-DTL-87929D**APPENDIX I**

8. Other Inspections (e.g., Pre-Flight, Post-Flight, Recertification, etc.) (see [I.3.5.5.1.8](#))

b. Inspection Evaluation (see [I.3.5.5.2](#))

c. Instructions for disposition of rejected items (see [I.3.5.5.3](#))

d. Classification of visual defects tables (see [I.3.5.5.4](#))

I.3.5.5.1 Types of inspections.

I.3.5.5.1.1 Receiving inspection (RI). General inspection guidelines are contained in TO 11A-1-10 and shall be used as a guide to establish inspection criteria. Checkpoints required to perform inspection shall be presented in the classification of defects table.

I.3.5.5.1.2 Shipping inspection (SI). General inspection guidelines are contained in TO 11A-1-10 and shall be used as a guide to establish inspection criteria. Checkpoints required to perform inspection shall be presented in the classification of defects table.

I.3.5.5.1.3 Periodic inspection (PI). General inspection guidelines are contained in TO 11A-1-10 and shall be used as a guide to establish inspection criteria. Periodic inspection intervals will be established by the acquiring activity (see [6.2.j.8.\(1\)](#)). Inspections shall be performed on a sample-size basis. Unless otherwise specified by the acquiring activity, inspection quantities shall be based upon sample-size reject table(s) listed in TO 11A-1-10. Inspection criteria shall be presented in the classification of visual defects table which shall include all checkpoints necessary to ensure serviceability of the item(s). Specify items which are exempt from this inspection, if applicable. If inspection of inert training items is different than that required for live items, indicate inspection requirements.

I.3.5.5.1.4 Special inspections (SPI). Special inspections may be performed by direction of local authority, major commands, or appropriate ALC. Special inspections shall be performed in accordance with specific instructions from the directing authority.

I.3.5.5.1.5 Preissue inspection (PII). Inspections shall provide data required to ensure serviceability of an item prior to issue. General inspection guidelines are contained in TO 11A-1-10 and shall be used as a guide to establish inspection criteria. Specific inspection procedures shall be as directed in TO 11A-1-10.

I.3.5.5.1.5.1 Priority of issue. Priority of issue information shall contain notes pertaining to established and/or indefinite shelf life items. The following note for established shelf life items shall read: "When the lot number or date of manufacture cannot be identified, an item shall not be issued. If either the lot number or date of manufacture is known, the other may be obtained from (insert appropriate commodity directorate (OO-ALC/LIW or WR-ALC/LKG))." The following note for indefinite shelf life items shall read: "When the lot number cannot be identified, an item shall not be issued. Missing date of manufacture is not significant and shall not be cause for classifying the item unserviceable for issue. If only the lot number or date of manufacture is known and the unknown information is needed, it may be obtained from (insert appropriate commodity directorate [OO-ALC/LIW or WR-ALC/LKG])."

I.3.5.5.1.6 Returned munitions inspection (RMI). This inspection shall be performed on munitions returned from custody/consumption accounts prior to return to base stock (FV/FK). TO 11A-1-10 shall be used as a guide to establish inspection criteria. Specific inspection procedures shall be as directed in TO 11A-1-10.

I.3.5.5.1.7 Storage monitoring inspection (SMI). Storage monitoring inspections are performed to measure/monitor specific conditions or characteristics of stored assets. The inspection shall include all instructions necessary to accomplish this inspection. Criteria and guidelines are contained in TO 11A-1-10 and shall be used.

I.3.5.5.1.8 Other inspections. When specified, other inspections shall be included. The acquiring activity will specify the categories and types of inspections required (see [I.6.2](#)).

MIL-DTL-87929D**APPENDIX I**

I.3.5.5.1.8.1 Classification of visual defects tables. A classification of visual defects table shall be included. The classification of visual defects table shall identify inspection requirements by component and work unit code (WUC), inspection, defect classification (critical, major, or minor), how malfunctioned (How Mal), and corrective action to be taken to correct the defect or discrepancy. The table shall be arranged as follows:

Classification of Visual Defects

Component (WUC)	Inspection (Inspect for the following defects)	Defect Classification (How Mal)	Corrective Action
-----------------	--	---------------------------------	-------------------

I.3.5.5.1.8.2 Humidity indicator inspection cycle. If required by the acquiring activity, a humidity indicator inspection cycle table shall be provided in the following format (see I.6.2). The following note shall be added to the humidity indicator inspection cycle table:

NOTE

The local environment for each location shall be determined using TO 1-1-691. High humidity is listed as very severe/severe, medium humidity as moderate, and low humidity as mild.

Humidity Indicator Inspection Cycle (Months)**Local Environment**

	High Humidity	Medium Humidity	Low Humidity
Inside Storage			
Outside Storage			

I.3.5.5.2 Inspection evaluation. Inspection evaluation criteria shall be presented. Criteria in TO 11A-1-10 shall be used as a guideline or reference to TO 11A-1-10 shall be made.

I.3.5.5.3 Instructions for disposition of rejected items. This paragraph shall present the disposition instructions for end items/components that have been rejected. This paragraph shall contain a reference to AFI 21-202 for the disposition of nonrepairable items.

I.3.5.5.4 Inspection - components SWPs. These SWPs shall include the information required by I.3.5.5. Inspection SWPs shall be provided for sections, major components, training munitions or differing configurations, as applicable.

I.3.5.6 Unpacking and Packaging WP (WP 060 00). This WP shall contain the following information applicable to the end items:

I.3.5.6.1 Unpacking. These instructions shall include procedures for uncrating, opening special containers, removing items, and handling of packing materials. Procedures for disposition of empty reusable containers shall be included. Procedures for unpacking items packaged in simple hermetically-sealed containers or simple one-time use containers need not be included. Include instructions for marking containers when shelf/service life is affected by unpacking. The following paragraph shall be included: "The safety requirements of AFMAN 91-201 shall be followed when unpacking. Before opening a container, ensure that all markings are legible. Record markings that may be destroyed by opening the container. Retain serviceable packing for possible reuse."

I.3.5.6.2 Packaging. A description and illustration of the original shipping and storage containers for the service (end) item, training/dummy item, and major components shall be provided (as applicable). Special Packaging Instructions/Transportation Packaging Orders (SPI/TPO) shall be used as the source document. This paragraph shall contain, at minimum, the following:

MIL-DTL-87929D**APPENDIX I**

- a. Step-by-step procedures for installing items in container, in all standard storage and shipping configurations.
- b. Preservation instructions.
- c. Applicable container marking and sealing requirements.

I.3.5.6.3 Unpacking and Packaging SWPs. These SWPs shall include the information required by I.3.5.6. An Unpacking and Packaging SWP shall be provided for sections, major components, training munitions, or differing configurations, as applicable.

I.3.5.7 Maintenance WP (WP 070 00). Procedures for authorized maintenance of the munitions shall be included. A list of materials to be used shall be included. Consumable materials shall be in accordance with I.3.2.g. Those required for cleaning, painting, and markings shall be listed only in WP 030 00 and in this WP as specified herein. Arrangement of the WP shall be in the following order, as applicable:

- a. Safety Summary and Accident Prevention (see I.3.2.f).
- b. Sequence of Operations (see I.3.5.7.1).
- c. Torque Requirements Table (see I.3.5.7.2).
- d. Maintenance (see I.3.5.7.3).
- e. Preparation for Use (see I.3.5.7.4).
- f. Assembly (see I.3.5.7.5).
- g. Checkout (see I.3.5.7.6).
- h. Servicing (see I.3.5.7.7).
- i. Disassembly (see I.3.5.7.8).
- j. Component Repair (see I.3.5.7.9).
- k. Cleaning, Corrosion Control, Painting, and Marking (see I.3.5.7.10).

I.3.5.7.1 Sequence of operations. When deviations are not authorized, the acquiring activity will provide the appropriate sequence of work to be performed. Otherwise, this paragraph shall contain the following statement: "Production techniques involving preparation of more than one item may require deviations from the work sequence. Several procedures may be performed simultaneously, and in different work areas, providing the preceding and subsequent tasks are not invalidated or interfered with and that all safety and reliability requirements are observed."

I.3.5.7.2 Torque requirements table. This table shall be arranged as follows and contain the appropriate information in each column:

Torque Requirements

Part Number	Nomenclature	Torque
-------------	--------------	--------

I.3.5.7.3 Maintenance. Maintenance procedures described herein shall include all authorized maintenance actions, including those required to respond to the defects noted as a result of inspections conducted in accordance with WP 050 00 and/or tests conducted in accordance with WP 080 00.

I.3.5.7.4 Preparation for use. These instructions shall include all procedures for preparing an item for use, such as inspection of components, assembly (buildup), installation of components, alignment, test, and complete inspection, as applicable. When preparation for use/assembly results in change of identification or DoD Ammunition Code (DODAC), procedures shall be included to ensure all applicable functions are notified.

I.3.5.7.5 Assembly. Detailed assembly instructions shall be provided. Appropriate illustrations shall be included.

I.3.5.7.6 Checkout. Checkout instructions for assembled items shall be provided.

MIL-DTL-87929D**APPENDIX I**

I.3.5.7.7 Servicing. Servicing instructions shall be provided and shall include lubrication, adjustment and any other servicing requirements as applicable.

I.3.5.7.8 Disassembly. Detailed disassembly instructions shall be provided. These procedures shall configure the item for packaging.

I.3.5.7.9 Component Repair. This paragraph shall state the repair limitations for the munitions and shall identify those maintenance tasks which can be performed on assembled munitions. These instructions shall include all procedures authorized for accomplishment at the level of maintenance determined by the acquiring activity and shall include those expanded step-by-step procedures for corrective actions in the Classification of Defect Tables. Torque requirements shall be included in textual form.

I.3.5.7.9.1 Removal/replacement. Detailed instructions for removal/replacement of items/components shall be provided. It shall also include a statement that all replacement components shall be inspected in accordance with applicable WP/SWP prior to assembly. Appropriate illustrations shall be included.

I.3.5.7.9.2 Component repair. Instructions shall be provided for the maintenance/repair of authorized components. Appropriate illustrations shall be included.

I.3.5.7.10 Cleaning, corrosion control, painting, and marking.

I.3.5.7.10.1 Cleaning/corrosion control materials and procedures. Procedures for cleaning/corrosion control shall be included. A reference to TO 1-1-691 for basic corrosion control procedures shall be provided. A table shall be included and arranged in the following format:

Cleaning/Corrosion Control Materials and Procedures

Discrepancy	Material	Specification/Part Number	Tools and Procedures
-------------	----------	---------------------------	----------------------

- a. Discrepancy. The discrepancy to check for.
- b. Material. The material(s) to be used.
- c. Specification/Part Number. The military, Government, or commercial specification number or part number shall be shown.
- d. Tools and Procedures. The tools and procedures to correct the discrepancy.

I.3.5.7.10.2 Painting and markings. This paragraph shall provide a brief description of the purpose of painting and marking requirements and call out the table which presents an approved materials list to be used to accomplish the required task. A reference shall be made to WP 010 00 for the marking requirements of the item and container. This paragraph shall also contain the following statement: "Apply protective paints in accordance with TO 1-1-8." The table shall be arranged in the following format:

Paint and Marking Materials

Item	Specification Number/Color Number per FED-STD-595	Use
------	--	-----

- a. Test. The component/item to be painted/marked.
- b. Specification Number/Color Number. The military, Government, or commercial specification number, and color per FED-STD-595.
- c. Use. Identifies the use or purpose of the materials.

I.3.5.7.11 Maintenance SWPs. These SWPs shall include the information required by [I.3.5.7](#), except [I.3.5.7.9.1](#) and [I.3.5.7.9.2](#). SWPs shall be provided for sections, major components, training munitions or differing configurations, as applicable.

I.3.5.8 Illustrated Parts Breakdown WP (WP 998 00). An IPB work package shall be prepared and numbered 998 00. The format and contents of the IPB WP shall be in accordance with MIL-PRF-38807. All references to "Figure Number" shall be changed to "WP/SWP Number and Figure Number".

MIL-DTL-87929D**APPENDIX I**

I.3.5.8.1 Illustrated Parts Breakdown SWPs. These SWPs shall include the information required by I.3.5.8. SWPs shall be provided for sections, major components, training munitions or differing configurations, and numbered accordingly, as applicable.

I.3.5.8.2 Separate manual. When specified, the IPB shall be developed as a separate manual. When the IPB is provided as a separate manual it shall be prepared in accordance with MIL-PRF-38807 (see I.6.2).

I.3.5.9 Testing/Reprogramming WP (WP 080 00). When specified, this WP shall be included (see I.6.1). This WP shall contain the following information.

I.3.5.9.1 Testing and reprogramming procedures. This WP shall include instructions and step-by-step procedures using specified equipment for electrical, mechanical, and functional testing of munition items and/or reprogramming. Electrical continuity/resistance checks shall include, as applicable, meter preparation procedures, protective shielding, electrical grounding, and tie-down requirements. When applicable, reference to appropriate SWPs for specialized testing shall be included.

I.3.5.9.2 Records/documentation. When required for the weapon system, procedures shall be included to record and report test/reprogramming records and documentation.

I.3.5.9.3 Test evaluation. This paragraph shall follow test requirements and the title of the paragraph shall be "Test Evaluation". Criteria and procedures shall be provided for evaluation of tests conducted. This paragraph shall also present the disposition instructions for items that have been rejected. This paragraph shall also contain a reference to AFI 21-202 for the disposition of nonrepairable items.

I.3.5.10 Contingency Procedures WP (WP 090 00). When specified, this WP shall be included and shall contain the following information as required (see I.6.2):

I.3.5.10.1 Concept of operations. Information shall be included which describes the concept of operations, e.g. an explanation of rapid assembly during contingency operations.

I.3.5.10.2 Breakout and preparation for use. If required by the acquiring activity, this information shall provide the minimum instructions required to prepare assembled munitions for use during contingency operations.

I.3.5.10.3 Unpacking, inspection, and assembly. If required by the acquiring activity, this information shall provide the minimum instructions required to unpack, inspect, and assemble munitions for contingency operations.

I.3.5.11 Depot Related Data and Special Instructions WP (WP 100 00). When specified, this WP shall be included (see I.6.2). The acquiring activity will provide the appropriate data for storage requirements and detailed procedures for disassembly, repair, assembly, and inspection/testing of applicable components.

I.3.5.12 Additional WPs (WP 110 00 through 997 00). When specified, additional WPs (e.g. maintenance for unique support equipment, unique testers, etc.) are required (see I.6.2), the acquiring activity will specify the type of WP and the information to be included.

I.3.6 Chemical Munitions/Biological Research Agents manual. When specified, CMBR agents manuals shall be prepared in accordance with MIL-DTL-87929 and this appendix (see I.6.2).

I.3.6.1 Safety Summary and Accident Prevention WP (WP 020 00). See I.3.5.2.

I.3.6.1.1 Decontamination. These instructions shall include step-by-step procedures for decontamination of the CMBR agents, when this information is included in general or other technical manuals, such manuals shall be referenced. If the agent or decontamination solution is classified, the procedures shall be included in a separate supplement. When included, these procedures shall be arranged in the following order:

- a. Description (see I.3.6.1.1.1).
- b. Symptoms (see I.3.6.1.1.2).
- c. First Aid (see I.3.6.1.1.3).
- d. Decontamination of personnel (see I.3.6.1.1.4).
- e. Decontamination of clothing (see I.3.6.1.1.5).
- f. Decontamination of equipment (see I.3.6.1.1.6).

MIL-DTL-87929D**APPENDIX I**

- g. Preparation, sampling, and testing of decontamination solution (see [I.3.6.1.1.7](#)).
 - h. Minor leaks in CMBR agent items (see [I.3.6.1.1.8](#)).
 - i. Major leaks in CMBR agent items (see [I.3.6.1.1.9](#)).
 - j. Decontamination of CMBR agent items (see [I.3.6.1.1.10](#)).
 - k. CMBR agent spills (see [I.3.6.1.1.11](#)).
- I.3.6.1.1.1 Description. A general description of the CMBR agent and the decontaminant(s) shall be included.
- I.3.6.1.1.2 Symptoms. Symptoms shall be listed which indicate that personnel who have been contaminated by a CMBR agent.
- I.3.6.1.1.3 First aid. First aid instructions shall be provided for treatment of personnel who have been contaminated by a CMBR agent.
- I.3.6.1.1.4 Decontamination of personnel. Procedures shall include the steps required for decontamination when wearing impermeable protective clothing and also the steps required for decontamination of personnel not wearing protective clothing.
- I.3.6.1.1.5 Decontamination of clothing. Procedures for decontaminating clothing which has been exposed to the CMBR agent shall be given.
- I.3.6.1.1.6 Decontamination of equipment. Instructions shall include all procedures for the decontamination of equipment involved in minor/major leaks and spills of a CMBR agent.
- I.3.6.1.1.7 Preparation, sampling, and testing of decontamination solution. Procedures to prepare, sample, and test the decontamination solution shall be provided.
- I.3.6.1.1.8 Minor leaks in CMBR agent items. The corrective procedures to follow when minor leaks occur in the CMBR agent items shall be given.
- I.3.6.1.1.9 Major leaks in CMBR agent items. The corrective procedures to follow when major leaks occur in the CMBR agent items shall be given.
- I.3.6.1.1.10 Decontamination of CMBR agent items. Procedures to follow in decontaminating the CMBR agent items after completion of a mission, prior to storage or reuse, as applicable, shall be given.
- I.3.6.1.1.11 CMBR agent spills. Corrective procedures to follow in decontaminating the area after a CMBR agent spill shall be given.
- I.3.6.2 Storage and Handling Requirements WP (WP 040 00). In addition to the requirements of [I.3.5.4](#), this WP shall also contain the following.
- I.3.6.2.1 Preparation for storage. These instructions shall include, as applicable, the procedures for preparing the items for storage in shipping container(s), including repackaging. Procedures for both inert items and special items shall be given. The instructions shall be arranged in the following order:
- a. Internal component preparation (see [I.3.6.2.1.1](#)).
 - b. External component preparation (see [I.3.6.2.1.2](#)).
 - c. CMBR agent and residue removal (see [I.3.6.2.1.3](#)).
 - d. Seam and area taping (see [I.3.6.2.1.4](#)).
- I.3.6.2.1.1 Internal component preparation. Instructions shall cover the removal and replacement of any internal components that are to be accomplished prior to storage.
- I.3.6.2.1.2 External component preparation. Instructions shall be included for removal and replacement of any external components that are to be accomplished prior to storage.
- I.3.6.2.1.3 CMBR agent and residue removal. Instructions shall be included for the removal of a CMBR agent or the agent residue from the item.
- I.3.6.2.1.4 Seam and area taping. The seams and areas to be taped prior to storage shall be described. The tape shall be properly identified by part or military specification number. The CAGE Code shall be included if part number is given. An illustration shall be provided to facilitate location of the taping areas.

MIL-DTL-87929D**APPENDIX I**

I.3.6.3 Maintenance WP (WP 070 00). In addition to the requirements of [I.3.5.7](#) this WP shall contain the following.

I.3.6.3.1 Preparation for use. These instructions shall include step-by-step procedures for unpacking the munition (if applicable) and preparation of the munition for use. Special safety precautions to be observed shall be described.

I.3.6.3.2 Filling. These instructions shall include step-by-step procedures for filling, component selection and installation, preoperational check of filling equipment, and filling method, if applicable.

I.3.6.3.3 Maintenance. These instructions shall include step-by-step procedures for all maintenance authorized for accomplishment within the scope of the manual.

I.4 DOCUMENT TYPE DEFINITION.

I.4.1 SGML document type definition. The document type definition (DTD) provides the structure and content of documents prepared in accordance with this specification. Data to be delivered digitally in accordance with this specification shall be SGML tagged using the DTD applicable to Specialize Storage and Maintenance Procedures; AUR Munitions and Associated Support Equipment, Conventional Components, and CMBR Agents Technical Manual.

I.5 DETAILED DESCRIPTION

I.5.1 Document type definition. The DTD provides the structure and content of documents prepared in accordance with this specification. The DTD is available in a digital format. See [A.4.3](#), for information on obtaining the file.

I.5.2 Tag description table. The TDT provides detailed descriptions of the tags above and provides the element tagging structure, full element name, tag minimization requirements, element structure, referencing elements, source paragraph, and attribute descriptions unique to the element. See [A.4.3](#), for information on obtaining this table.

I.6 NOTES.

I.6.1 Acquisition requirements. Acquisition documents must specify requirements (see [6.2](#)).

I.6.2 Definitions.

I.6.2.1 Conventional components/munitions. Includes all ammunition, munition fillers, demolition material, solid rocket motors, liquid propellants, cartridges, pyrotechnics, mines, bombs, grenades, warheads of all types, explosive elements of ejection/egress and aircraft systems, explosive components of missile systems and space systems, and assembled kits and devices containing explosive material.

I.6.2.2 Chemical munitions. For the purposes of this appendix, a chemical munition is a nonnuclear munition in which the filler is primarily a chemical agent. Chemical agents do not include riot control agents, chemical herbicides, or smoke and flame

I.6.2.3 Biological research agents. For the purposes of this appendix, biological research agents are those small quantities of biological agents (including toxins) necessary for research and development of defense measures and material, such as immunizations, detection and warning devices, and other safety measures.

MIL-DTL-87929D**APPENDIX J****SPECIAL REQUIREMENTS FOR PARACHUTE PACKING PROCEDURES TECHNICAL MANUAL****J.1 SCOPE.**

J.1.1 Scope. This appendix provides the special or unique criteria, in addition to the provisions of this specification, required for development of a Parachute Packing Procedures Technical Manual (TM). The markup tags described herein are based on rules outlined in MIL-HNDBK-28001 and ISO 8879. The Document Type Definition (DTD) subset associated with this appendix provides the structure and content of documents prepared in accordance with this specification. The information contained in and referred to in this appendix forms a part of the standard and is intended for compliance. The Document Type Definition (DTD) referenced herein may be obtained directly from the preparing activity (see [A.4.3](#)).

J.2 APPLICABLE DOCUMENTS.**J.2.1 Government documents.**

J.2.1.1 Specifications, standards, and handbooks. Not applicable.

J.2.1.2 Other Government documents, drawings, and publications. The following other Government documents, drawings, and publications form a part of this document to the extent specified herein. Unless otherwise specified, the issues of these documents are those cited in the solicitation or contract.

PUBLICATIONS**AIR FORCE TECHNICAL MANUALS****TO 00-25-241**

Parachute Logs and Records

(Copies of documents required by contractors in connection with specific procurement functions should be obtained from the acquiring activity or as directed by the contracting officer.)

J.2.1.3 Non-government standards and other publications.

J.2.2 Non-government standards and other publications.

J.2.2.1 Non-government publications. The following documents form a part of this document to the extent specified herein. Unless otherwise specified, the issues of these documents are those cited in the solicitation or contract.

NON-GOVERNMENT PUBLICATIONS**INTERNATIONAL ORGANIZATION FOR STANDARDIZATION (ISO)****ISO 8879**Information Processing - Text and Office Systems - Standard
Generalized Markup Language (SGML) (DoD Adopted)

(Application for copies should be addressed to Standardization Documents Order Desk, Building 4D, 700 Robbins Avenue, Philadelphia, PA 19111-5094, for issue to DoD activities. Others may purchase copies from the American National Standards Institute, 11 West 42nd Street, New York, NY 10036.)

J.3 SPECIAL REQUIREMENTS.

J.3.1 Parachute packing procedures manual. The technical manual shall include detailed procedures for inspection, repair, assembly, and packing of personnel, cargo, aerial delivery, and aircraft deceleration parachutes.

J.3.2 Inspection WP. The inspections shall be presented under the following headings. When the parachute consists of a number of major components, each component shall be treated individually.

J.3.2.1 General. Information under the "General" heading shall emphasize the importance of properly maintaining the parachute. When the parachute incorporates, or is designed to incorporate, explosive munition devices, the following warning shall be added:

MIL-DTL-87929D**APPENDIX J****WARNING**

When an abnormal condition is noted and pertinent procedures contained herein do not specifically relate to the noted irregularity, work shall be stopped and technically qualified guidance shall be obtained before continuing the operation.

J.3.2.2 Inspection periods. Inspection intervals will be provided by the acquiring activity. A table, specifying the intervals between inspections for each activity assigned to the care of the parachute, shall be furnished. The table shall specify complete inspection of the parachute prior to service packing for use, (interval) Day Periodic External Inspection, (interval) Day Periodic Complete Inspection.

J.3.2.2.1 Inspection prior to packing. A statement shall be provided covering the extent of inspection required prior to packing of the parachute.

J.3.2.2.2 (Interval) day periodic external inspection. Detailed instructions shall be provided covering inspections of external parts of the packed parachutes in service, stored or installed in aircraft. Instructions shall specify requirements for processing a complete inspection if results of the external inspection indicates the need.

J.3.2.2.3 (Interval) day periodic complete inspection. It shall be stated that all packed parachutes shall be unpacked, completely inspected and repacked at least once every (interval) days, or more if conditions warrant.

J.3.2.3 Preflight inspection. Instructions shall be provided covering preflight inspection of the parachute, including necessary data for adequate inspection of the automatic or mechanical devices if incorporated in the parachute design.

J.3.2.4 Complete inspection procedures. A brief statement shall be provided covering the extent of inspection required at each echelon of maintenance. Subsequent paragraphs and illustrations shall provide detailed instructions for complete inspection of each major component, including operational inspection of applicable automatic or mechanical devices, and extent and types of damage, or extent of wear, that require repair or replacement. Damage not requiring repair shall not be illustrated.

J.3.3 Repair procedures WP. Instructions for repair of the major components of the parachute shall be provided.

J.3.3.1 Estimated cost of repair. Instructions shall be furnished for determining economical repair costs for reconditioning the parachute. The text shall be supplemented with tables showing percentage of cost for new parts to be expected for repairs, and estimated costs for significant repairs, such as splicing, patching, etc.

J.3.3.2 Detailed repair procedures. Instructions shall be provided for repair or replacement of worn or damaged components which comprise the parachute. A materials table shall cite applicable military specifications and shall be furnished in the following format:

Parachute Component Repair or Replacement

Component	Item	Material	Specification
-----------	------	----------	---------------

J.3.3.3 Cleaning. Minimum instructions shall be provided for removal of loose foreign matter from the parachute. Reference shall be made to the manual that provides detailed cleaning.

J.3.3.4 Testing. Instructions covering functional testing of the parachute shall be included. Remedial action shall be described for failures of the parachute to meet the tests.

J.3.4 Packing procedures WP. Detailed instructions for assembling and packing the parachute shall be furnished. Information shall be presented under the following headings, and any additional headings deemed essential:

J.3.4.1 Facilities and equipment. Data shall be provided regarding facilities, space, tables, and other major equipment, required to accomplish packing.

J.3.4.2 Packing. Detailed procedures shall be provided covering the proper layout of the parachute, assembly of each component, folding, packing, and other procedures required for final preparation of the

MIL-DTL-87929D**APPENDIX J**

parachute. These instructions shall be provided in step-by-step sequence and supplemented with essential illustrations. Procedures shall specify required dimensional size of the parachute in packed configuration and other dimensions essential for proper installation or application for which the parachute is designed. Parachute logs and records shall be in accordance with TO 00-25-241.

J.4 DOCUMENT TYPE DEFINITION.

J.4.1 SGML document type definition. Data to be delivered digitally in accordance with this specification shall be SGML tagged using the DTD applicable to Parachute Packing Procedures Technical Manual.

J.5 DETAILED DESCRIPTION.

J.5.1 Document type definition. The DTD associated with this appendix provides the structure and content of documents prepared in accordance with this specification. The DTD is available in a digital format. See [A.4.3](#), for information on obtaining the file.

J.5.2 Tag description table. The tag description table (TDT) provides detailed descriptions of the tags and provides the element tagging structure, full element name, tag minimization requirements, element structure, referencing elements, source paragraph, and attribute descriptions unique to the element. See [A.4.3](#), for information on obtaining this table.

MIL-DTL-87929D**APPENDIX K****SPECIAL REQUIREMENTS FOR OPERATOR INSTRUCTIONS (HAND-HELD FLIGHT COMPUTERS) TECHNICAL MANUAL****K.1 SCOPE.**

K.1.1 Scope. This appendix provides the special or unique criteria, in addition to the provisions of this specification, required for development of an Operator Instructions (Hand-Held Flight Computers) Technical Manual (TM). The markup tags described herein are based on rules outlined in MIL-HNDBK-28001 and ISO 8879. The Document Type Definition (DTD) subset associated with this appendix provides the structure and content of documents prepared in accordance with this specification. The information contained in and referred to in this appendix forms a part of the standard and is intended for compliance. The Document Type Definition (DTD) referenced herein may be obtained directly from the preparing activity (see [A.4.3](#)).

K.2 APPLICABLE DOCUMENTS.

Not applicable.

K.3 SPECIAL REQUIREMENTS.

K.3.1 Hand-held flight computer operation instructions. This manual covers operation of hand-held range, takeoff and landing, and air navigation computers. These computers may be disc or slide rule types constructed of heavy paper, metal, or plastic, and inscribed with the scales and calibrations needed by the aircrew for solving appropriate problems.

K.3.1.1 Preparation. The general manner of preparation shall be in accordance with [3.4.1](#) and [3.4.1.1](#), except it shall not contain alphabetical or master list of special tools, test equipment, and consumables WPs. Page size shall be determined by the size of the carrying case for the computer.

K.3.1.2 Text content. The manual shall not deal with detailed theory of operation, but shall contain information necessary for the efficient operation of the computer by personnel having operating experience.

K.3.1.3 Abbreviations. Abbreviations on the computer itself shall be abbreviated in the same manner when reference is made thereto.

K.3.1.4 Illustrations. Illustrations and diagrams shall be used to clarify and supplement the related text.

K.3.1.5 Operation WP. This WP shall contain detailed practical operation instructions in proper sequence for a complete step-by-step, start-to-finish cycle. Such instructions shall be sufficient to satisfy the requirements of personnel responsible for operation of the computer. Preliminary adjustments and settings, explanation of each step and where to obtain readings shall be included. Representative examples shall be provided. When operation is relatively simple, the operation instructions may be included in the foreword WP.

K.4 DOCUMENT TYPE DEFINITION.

K.4.1 SGML document type definition. Data to be delivered digitally in accordance with this specification shall be SGML tagged using the DTD applicable to Operator Instructions (Hand-Held Flight Computers) Technical Manual.

K.5 DETAILED DESCRIPTION.

K.5.1 Document type definition. The DTD associated with this appendix provides the structure and content of documents prepared in accordance with this specification. The DTD is available in a digital format. See [A.4.3](#), for information on obtaining the file.

K.5.2 Tag description table. The tag description table (TDT) provides detailed descriptions of the tags and provides the element tagging structure, full element name, tag minimization requirements, element structure, referencing elements, source paragraph, and attribute descriptions unique to the element. See [A.4.3](#), for information on obtaining this table.

MIL-DTL-87929D**APPENDIX L****SPECIAL REQUIREMENTS FOR INSTALLATION-ENGINEERING FACILITY
(GROUND C-E EQUIPMENT) TECHNICAL MANUAL****L.1 SCOPE.**

L.1.1 Scope. This appendix provides the special or unique criteria, in addition to the provisions of this specification, required for development of an Installation-Engineering Facility (for Ground Communication-Electronic [C-E] Equipment) Technical Manual (TM). The markup tags described herein are based on rules outlined in MIL-HNDBK-28001 and ISO 8879. The information contained in and referred to in this appendix forms a part of the standard and is intended for compliance. The Document Type Definition (DTD) referenced herein may be obtained directly from the preparing activity (see [A.4.3](#)).

L.2 APPLICABLE DOCUMENTS.

L.2.1 Government documents. Not applicable.

L.2.1.1 Other Government documents, drawings, and publications. The following other Government documents, drawings, and publications form a part of this document to the extent specified herein. Unless otherwise specified, the issues of these documents are those cited in the solicitation or contract.

PUBLICATIONS**AIR FORCE MANUALS****AFI 33-150**

Base-Level Planning and Implementation

(Copies of documents required by contractors in connection with specific procurement functions should be obtained from the acquiring activity or as directed by the contracting officer.)

L.2.2 Non-government standards and other publications.

L.2.2.1 Non-government publications. The following documents form a part of this document to the extent specified herein. Unless otherwise specified, the issues of these documents are those cited in the solicitation or contract.

NON-GOVERNMENT PUBLICATIONS**INTERNATIONAL ORGANIZATION FOR STANDARDIZATION (ISO)****ISO 8879**Information Processing - Text and Office Systems - Standard
Generalized Markup Language (SGML) (DoD Adopted)

(Application for copies should be addressed to Standardization Documents Order Desk, Building 4D, 700 Robbins Avenue, Philadelphia, PA 19111-5094, for issue to DoD activities. Others may purchase copies from the American National Standards Institute, 11 West 42nd Street, New York, NY 10036.)

L.3 SPECIAL REQUIREMENTS.

L.3.1 Installation-Engineering Facility (for Ground C-E Equipment) Manual. This manual shall support pre-engineering, site adaptation, planning, installation, and testing of a ground C-E equipment facility. The term "facility" used herein refers to a grouping or configuration of two or more ground C-E equipments, designed to satisfy a specific operational requirement. The manual shall contain information applicable to specific facilities. The manual will be used to engineer the installation of complex ground facilities and to test such facilities, after installation, for proper adjustment and operation.

L.3.1.1 Coverage. The installation-engineering facility manual is concerned with equipment compatibility, equipment interface, and cabling interconnections between equipment that allow the facility to function as an operational entity. Emphasis shall be placed on equipment configuration, unified installation, floor plans, engineering planning criteria, installation criteria, and facility tests.

L.3.1.1.1 Preparation. The general requirements shall be in accordance with [3.4.1](#) and [3.4.1.1](#). Tabular material shall be used whenever possible to present adequate information coverage.

L.3.1.2 Identification. The following identification shall appear on the title page, two lines below and in similar type as the term "Technical Manual":

MIL-DTL-87929D**APPENDIX L****AIR FORCE COMMUNICATIONS SERVICE
(E-I STANDARD)**

L.3.1.2.1 Facility title. The title page shall identify the facility by means of the exact title and C-E facility code number as indicated in AFI 33-150. The specific configuration shall be indicated as a secondary title under the facility code and title.

L.3.1.3 Foreword WP. In addition to the requirements of 3.4.3.2, this WP shall describe the facility and its purpose in terms of its function and shall, by means of functional descriptions of the facility and its components, describe how the function is accomplished. This WP shall also identify the interfaces of the facility with other portions of a system, subsystem, or facilities with reference to the illustrations specified in L.3.1.3.2.

L.3.1.3.1 Facility description and purpose. A complete summary of the facility shall be given in terms of its physical description. The facility's purpose shall be described in terms of its function and operational use. The relationship of the facility to interconnecting facilities shall be explained in terms of its major equipment function. A short summary of how the function of the facility is accomplished shall be included as a briefing orientation to engineering and installation personnel.

L.3.1.3.2 Illustrations. Block and other type diagrams shall be presented to show functional relationships between equipment, direction of signal flow, and interconnections with other facilities, remote control, or monitoring devices.

L.3.1.3.3 Tables. Tables are required to provide field engineers with adequate data for preplanning purposes. These tables consist of:

- a. Leading Particulars.
- b. Capabilities and Limitations.

L.3.1.3.3.1 Leading particulars. Tables shall list the logistic characteristics of the facility and the maximum- minimum variations from a standard equipment configuration. Tables shall present required facility floor space; dimensions and weight of individual equipment plus floor and wall projections required for inside plant installations; electromagnetic compatibility aspects; such as, transmitter power, receiver sensitivity, and bandwidth of equipment within the facility configuration. Tables shall include input power requirements, both ac and dc, including kVA loading (connected and demand); frequency, power factor, and number of phases for ac requirements; allowable frequency variation and voltage levels with allowable variations, plus other electrical data that will enable an engineer to plan an installation. Identification of all cables used in the facility shall be presented. Absolute identification shall be made by nomenclature, symbol, number, function, cable type, number and size of conductors, length, and terminal connectors. This presentation is required for all inter-equipment cabling and, when applicable, for input and output cables that link the facility to another or to auxiliary equipment. Special logistic techniques and procedures for transportation and storage shall also be listed in the tables.

L.3.1.3.3.2 Capabilities and limitations. The functional characteristics of the facility shall be identified in terms of types of operation, power output, frequency, pulse characteristics, antenna characteristics, RFI malfunctioning levels, sensitivity, selectivity, storage capacity, and memory type viewing parameters. The capabilities of the facility shall be further identified in terms of maximum range, coverage resolution, and accuracy. In addition, limiting factors of the facility shall be listed in terms of climatic effects; such as, ambient and operating temperatures, pressure, humidity, wind and ice loading; abnormal power stability requirements, maximum tolerances in frequency and voltage deviations; excessive floor or tower loading; and abnormal clearance requirements for installation, operation, and maintenance.

L.3.1.4 Master list of special tools, test equipment, and consumables WP. In addition to the requirements of 3.4.3.3, this WP shall also contain the following information:

L.3.1.4.1 Equipment supplied. This table shall contain an itemized list of all equipment and major components that are part of the facility. When engineered Standard Facility Equipment Lists (SFEL) exist, the equipment shall be listed under the specific SFEL package. Identification shall be made by military nomenclature when it exists, or by commercial nomenclature, by common name, and by manufacturer's part number. A very brief descriptive statement covering the purpose of each identified item shall also be presented.

MIL-DTL-87929D**APPENDIX L**

L.3.1.4.2 Equipment required but not supplied. This table shall list all equipment required to complete the facility configuration and SE (Support Equipment) required for installation and test that are not supplied through facility procurement. The listed equipment shall be adequately identified.

L.3.1.5 Engineering WP. This WP shall provide data to enable a field engineer to pre-engineer, site adapt, and accomplish engineering planning for the installation of a facility to meet a functional requirement in any specific geographical area. Data shall be presented in the following order:

- a. Siting Considerations.
- b. Supporting Structures.
- c. Power Requirements.
- d. Layout Planning.

L.3.1.5.1 Siting considerations. Basic information required to site adapt a standard facility configuration shall be presented. It shall consist of three primary areas of consideration: electronic, logistic, and geographical.

L.3.1.5.1.1 Electronic. Criteria shall be given for clear area requirements for Radio Frequency (RF) propagation, RF interference shielding and filtering, reflections, random noise sources, need for siting away from shock sources such as; blasting, heavy air or ground traffic, nuclear explosion. In addition, the electronic criteria shall take into account the possibility that a standard configuration may be augmented, or that specific equipment may be deleted under certain operating conditions.

L.3.1.5.1.2 Logistic. The siting criteria for logistic support shall contain information that will identify type and quantity of support required from electrical power sources, commercial communications facilities, fuel sources, water supply sources, drainage/sanitary waste systems, access roads and transportation services for physical installation, maintenance, and operation of the facility. The area required for storage and assembly of facility components during site preparation, installation and follow-on operation and maintenance shall also be described and diagramed.

L.3.1.5.1.3 Geographical. The geographical siting criteria shall contain a description and diagram for a normal or average site. The description shall include: dimensions and area of total site, including clear zones (areas); soil bearing characteristics required for installation and subsequent operation; grading and drainage limits; building and equipment electrical grounding. Limiting climatic and natural conditions that affect site construction, installation, and operation shall be listed and described.

L.3.1.5.2 Supporting structures. Complete structure data is required for any structure or portion thereof. The information shall include novel supporting structures or the criteria necessary to select or redesign interiors of existing structures to house facility elements. When new buildings are required, they shall be designated as permanent or semi permanent. Building types should be classified as fireproof, semi-fireproof, or ordinary. These requirements shall be indicated for both inside and outside plant.

L.3.1.5.2.1 Inside plant. The description of inside plant shall include, but not be limited to, the following criteria:

- a. A layout plan showing and describing gross floor space requirements for the facility, including access, maintenance, storage, operating and special use areas, minimum access door clearance (height and width required for access and egress of largest nonreducible facility component).
- b. Required clearance around equipment in operating area and other facility related spaces.
- c. Required floor to clear ceiling heights.
- d. Design live and wind loads with particular emphasis to unusual live load requirements.
- e. Special architectural features such as; cable openings, cable trenches, raised floor, acoustic treatment, outsized doors, removable wall panels.
- f. Special structural features such as; elevators, cranes, hoists, concentrated floor loads, cable anchors, structural ferrous bonding.
- g. Equipment heat gain per facility element.
- h. Inside summer and winter design dry bulb temperature, relative humidity.

MIL-DTL-87929D**APPENDIX L**

- i. Requirement for heating, air conditioning and mechanical ventilation, humidity control, plumbing, and special mechanical features, including water intrusion prevention.
- j. A statement of lighting requirements, including general and special lighting techniques and intensities, and hazard lighting.
- k. A qualitative and quantitative description of the electrical power required for operation and maintenance of the facility equipment, including identification and number of circuits, plus a riser diagram. Where the facility demands uninterrupted power, as a condition of specified operation, the elements so affected shall be identified in the break-out of power consumption. Facility kVA power consumption shall be given in both demand and connected load.
- l. Facility equipment, structures grounding, and lightning protection plan for both inside and outside plant equipment.
- m. Specific requirements for facility related intercom, telephone, and timing systems.
- n. Location and dimension of RF shielded and classified communications equipment areas.
- o. Orientation of inside plant to outside plant.
- p. Any novel feature peculiar to the facility.

L.3.1.5.2.2 Outside plant. The following points shall be explained and shown in the construction design criteria:

- a. Antenna site plot plan, including radomes, antenna warning lights, shelters, waveguide and transmission line routes, guys and guy anchors, grounding, fencing, etc. Controlling dimensions of equipment and structure spaces and clearance areas shall be given.
- b. Antenna/antenna component mounting plate(s) dimensional details.
- c. Antenna support foundation(s) and guy anchor reaction data.
- d. Description and physical data relating to transmission lines and cables and their suspension structures.
- e. Description and location for underground or buried cable, trenching, ducting, direct-burial cable, manholes, hand holds, or pull boxes for signal or control cables.
- f. Location and description of access roads, parking areas, equipment pads, and similar features required for installation, operation, and maintenance of the facility.
- g. Description of corrosion prevention and coating touch-up procedures after installation.

L.3.1.5.3 Power requirements. Power requirements shall be described which will indicate, in addition to that previously listed, interface between electrical construction effort and facility installation responsibilities.

L.3.1.5.3.1 Electrical system data. The number, electrical rating, and location of switching and distribution panels shall be given. As a part of this data, a listing of circuit breaker assignments for the equipment installation/operation/maintenance shall be included. The individual branch circuit breaker is to be described by its panel location and rating for frequency, voltage, phase, capacity, and whether automatic closure type is required.

L.3.1.5.4 Layout planning. Although the information required in L.3.1.5.1 through L.3.1.5.3.1 will provide engineering information requisite for installation planning, the information required herein shall correlate the data into a brief description of the principal factors that influence arrangement of the equipment, components, and hardware which make up the facility. These considerations shall entail such information as:

- a. Electronic: electromagnetic interference and potential radiation effects.
- b. Functional association of equipment.
- c. Allowable or design lengths of transmission lines and cables.
- d. Critical lengths of interconnecting signal cables.
- e. Circuit terminations, including tie-in with other facilities.

MIL-DTL-87929D**APPENDIX L**

- f. Remote control and monitoring (microwave versus landline or other type of transmission).
- g. Special intra- and inter-communications.
- h. Off-site location of commercial power and communication facilities.
- i. Physical consideration such as:
 - 1. Location of installed facilities (heating, air conditioning, and so forth).
 - 2. Efficiency of total installation, including ease of operation and maintenance (access requirements for operation, maintenance, installation, and removal).
 - 3. Space provision for potential expansion.
 - 4. Security fencing and parking area requirements.
 - 5. Required room illumination intensity, in foot-candles.
 - 6. Allowable sound intensity, in decibels.
 - 7. Topography.
 - 8. Water table limitations when underground structures are used.
 - 9. Permissible live loading and snow loading for flat roofs.
 - 10. Economy of construction and installation.
- j. Tabulation of minimum-maximum or, when applicable, exact distances between:
 - 1. Equipment, associated control units and indicators, electrical and physical plant facilities, and major equipment components.
 - 2. Equipment and building walls and ceilings.
 - 3. Similar and nonsimilar antennas and associated equipment.
 - 4. Antennas and buildings.
 - 5. Power and signal cables.
 - 6. Antennas and power and signal cables.
 - 7. Similar and nonsimilar, power, and communication transmission lines.

L.3.1.5.5 Installation-engineering drawings. Reference shall be made to all drawings required for engineering the installation of the facility. References shall be to dimensional drawings concerned with a typical or standard layout, including an overall site plan, equipment arrangement, simplified wiring diagrams, simplified floor and plot plans showing cross section elevations and utility arrangement. Additionally, the typical configuration shall be supplemented with minimum and maximum equipment configuration if variations are applicable.

L.3.1.6 Installation WP. This WP shall contain the information and instructions required to install a specific facility. Data content shall include, but not be limited to, the following items:

- a. Equipment and materials.
- b. Installation instructions.
- c. Manpower requirements.

L.3.1.6.1 Equipment and materials. Complete identification shall be given of all equipment and materials that will be required to accomplish an installation. Such information shall normally be presented in tabular form and shall consist of:

- a. A list of all engineered and approved SFELs that are applicable to the facility.
- b. A listing of equipment and material required but which are not included in approved SFELs. This listing shall include nomenclature (military when applicable, commercial if no military nomenclature exists) plus federal stock numbers of each listed item.

L.3.1.6.2 Installation instructions. Complete instructions shall be presented that will enable installation personnel to install the facility in accordance with established practices. These instructions shall not repeat contents of equipment installation TMs unless such information is required for clarity. Standard Air Force

MIL-DTL-87929D**APPENDIX L**

construction and installation practices and procedures shall not be presented; however, installation practices and procedures that are peculiar to the installation of the facility shall be presented. Required data shall include, but not be limited to:

- a. Instructions in the use of special installation tools and material handling equipment. Illustrations shall be used as required.
- b. Instructions and requirements, if applicable, for sequential installation of equipment, components and materials.
- c. Installation instructions for:
 1. Inside plant equipment and material, including interconnecting cabling and wiring.
 2. Erection of self-supporting and guyed towers, radomes, antennas, and other related housing and supporting structures.
 3. Tower mounted and other outside plant equipment, including use of special lift equipment.
 4. Construction of overhead, underground and buried power, control and communication lines.
 5. Fabrication of special signal cables that are not included in SFELs.
 6. Waveguides and signal transmission lines.

L.3.1.6.2.1 Installation drawings. Reference shall be made to all drawings required to install the facility. The information shall contain a list of standard building or room construction drawings, plus the applicable specifications that govern such construction drawings and such construction. A list shall also be included, when applicable, of drawings that pertain to outside plant such as; tower construction and erection, plus the applicable specifications as these drawings pertain to facility installation. In addition to lists of Air Force drawings that apply to the facility, this chapter shall contain simplified drawings, wiring diagrams, wiring and cable lists (drawings), and miscellaneous illustrations that are necessary to supplement existing data or to clarify installation instructions presented in the standard.

L.3.1.6.3 Manpower requirements. Total manpower requirements to install the facility shall be presented. This information shall be expressed in man-days or man-weeks and shall include installation plus time required to test the installed facility. The information shall show work categories and the amount of time required to accomplish each category.

L.3.1.7 Test WP. This WP shall contain procedures for conducting tests required to insure that the installed facility is technically adequate to accomplish its operational objective. The information shall include, but not be limited to, these types of tests:

- a. Pre-shakedown.
- b. Shakedown.
- c. Operational.

L.3.1.7.1 Pre-shakedown. The pre-shakedown test shall include the requirement for physical inspection to verify conformance with installation requirements and safety; electrical measurements to confirm the adequacy and stability of primary power, voltage, frequency, etc., and preliminary adjustments to be made prior to shakedown and operational tests.

L.3.1.7.2 Shakedown. The shakedown test is essentially a running time test for each electronic part that composes the facility. The manual shall specify the duration of time required for the shakedown test in order to insure that the facility will operate adequately to accomplish its operational requirement. Real or simulated operating conditions shall be prescribed so that the whole facility and its parts are at normal functioning voltage, current, temperature, and so forth.

L.3.1.7.3 Operational. A description of the tests required to assure that all the operational functions of the facility have been met shall be given. The purpose of these tests is to provide procedures for accurate determination of performance levels. The tests shall include detailed instructions, including required duration of tests, and shall make provision for permanent recording of data. Flight and Electronic Countermeasures (ECM) tests shall be included, when applicable, in the list of tests to be conducted,

MIL-DTL-87929D**APPENDIX L**

however, the requirement for flight tests shall be held to an absolute minimum, relative to accurate determination of facility performance levels.

L.3.1.7.3.1 Test sequence. The preferred sequence of tests shall be stated. In sequence listing, a step-by-step procedure for each test shall be presented, or a reference shall be made to the publication in which the prescribed procedures can be found. Test procedures shall include:

- a. Performance specifications.
- b. Test interface between test equipment and the facility to include cables, plugs, attenuators, etc.
- c. Test equipment required.
- d. Sample test data sheets or oscilloscope illustrations, pen charts, computer readouts, etc.
- e. Test configuration diagram.
- f. The following statement shall appear following the description of operational test: "Accomplish the performance, alignment, and adjustment routines on the installed facility in the presence of representatives of the using command."

L.3.1.8 Definitions peculiar to installation-engineering facility manuals.

L.3.1.8.1 C-E equipment. The physical components of a facility, usually denoting a major end item having a military nomenclature (AN/-, TS-, OA-, etc.) as opposed to a part number.

L.3.1.8.2 C-E facility. A group of equipment or components engineered and installed to perform an operational function in support of a requirement, system, or mission.

L.3.1.8.3 Site. A physical location of ground C-E equipment or facilities, such as: Station, Base, Depot, ALC, Field, Fort, Launching Area, Camp, Installation, and Arsenal.

L.3.1.8.4 System. A numbered part of a Mission Category, such as: 480L, 465L, etc., that may consist of one or more facilities or sites.

L.3.1.8.5 SFEL. Standard Facility Equipment List.

L.4 DOCUMENT TYPE DEFINITION.

L.4.1 SGML document type definition. The document type definition (DTD) provides the structure and content of documents prepared in accordance with this specification. Data to be delivered digitally in accordance with this specification shall be SGML tagged using the DTD applicable to Installation-Engineering Facility (Ground C-E Equipment) Technical Manual.

L.5 DETAILED DESCRIPTION.

L.5.1 Document type definition. The DTD provides the structure and content of documents prepared in accordance with this specification. The DTD is available in a digital format. See [A.4.3.](#) for information on obtaining the file.

L.5.2 Tag description table. The tag description table (TDT) provides detailed descriptions of the tags above and provides the element tagging structure, full element name, tag minimization requirements, element structure, referencing elements, source paragraph, and attribute descriptions unique to the element. See [A.4.3.](#) for information on obtaining this table.

MIL-DTL-87929D**INDEX****A**

Abbreviations.....	2, 75
Accept/reject criteria.....	46
Access.....	49
Accessories.....	3
Accessory maintenance.....	22
Accidents/Incidents.....	62
Acquisition requirements.....	26, 71
Additional information.....	50
Additional reference material.....	55
Additional WPs (WP 110 00 through 997 00).....	69
(Aircraft designation) aircraft program operation.....	52
(Aircraft designation) ASIP description.....	52
Aircraft engine testing and trending procedures manual.....	33
Aircraft Structural Integrity Program (ASIP) manual.....	51
Alphabetical index WP.....	10
Analysis.....	20
Applicability column.....	18
Applicable references.....	52
Applicable support equipment.....	13
Applicable TCTOs.....	13
Application.....	26
Arming/de-arming procedures.....	13
Arrangement.....	8
Assembly.....	16, 21, 67
Assembly/disassembly of major sections and subassemblies.....	22
Assignment of symbols.....	8
Assignment of WP/SWP titles.....	4
ATE operator test procedures manual.....	54
Attribute Description Table (ATD).....	32, 37, 39

B

Backup NDI procedure (technique).....	50
Bench test setup (when applicable).....	20
Biological research agents.....	71
Breakout and preparation for use.....	69

C

C-E equipment.....	82
C-E facility.....	82
Cable fabrication.....	20
Capabilities and limitations.....	55, 77
Categories of manuals.....	2
Cautions.....	28
Changes from previous issue.....	29
Checklists.....	3
Checkout.....	16, 67
Chemical munitions.....	71
Chemical Munitions/Biological Research Agents manual.....	69
Circuit analysis (detailed).....	20
Circuits.....	6

MIL-DTL-87929D

Classification of visual defects tables.....	66
Cleaning.....	21, 73
Cleaning and temporary protection WP.....	41
Cleaning, corrosion control, painting, and marking.....	68
Cleaning/corrosion control materials and procedures.....	68
Closing and sealing.....	24
CMBR agent and residue removal.....	70
CMBR agent spills.....	70
Combination diagrams.....	7
Combined maintenance manual.....	2
Commodity items and support equipment.....	46
Common tools.....	63
Complete inspection procedures.....	73
Compliance.....	25
Component repair.....	68
Component Repair.....	68
Composite.....	19
Computer software.....	55
Concept of operations.....	69
Configuration Table.....	61
Consumable materials.....	13
Consumables.....	28
Contents.....	23, 41
Contingency procedures.....	13
Contingency Procedures WP (WP 090 00).....	69
Conventional components/munitions.....	71
Corrosion inspections.....	42
Corrosion prevention.....	21
Corrosion prone areas WPs.....	41
Corrosion removal and repair procedures.....	42
Coverage.....	76

D

Danger zones.....	62
Decontamination.....	69
Decontamination of clothing.....	70
Decontamination of CMBR agent items.....	70
Decontamination of equipment.....	70
Decontamination of personnel.....	70
Defect description.....	49
Definitions.....	28, 44, 46, 57, 71
Definitions peculiar to installation-engineering facility manuals.....	82
Degrees of storage.....	24
Depot maintenance manual.....	2
Depot Related Data and Special Instructions WP (WP 100 00).....	69
Description.....	70
Description of item.....	61
Description of system tie-in of equipment and accessories.....	19
Detailed repair procedures.....	73
Diagnostic Flow Chart (DFC).....	57
Diagrams.....	6
Difference data WP.....	14
Disassembly.....	20, 68

MIL-DTL-87929D

Document type definition.....	44, 50, 53, 57, 71, 74–75, 82
Drop criteria.....	16, 62
Dropped munitions/component processing.....	62
DTD.....	32, 37, 39

E

Eddy current.....	49
Electrical and pneumatic power requirements.....	63
Electrical system data.....	79
Electronic.....	78
Electronic presentation requirements.....	2
Engineering production drawings.....	46
Engineering WP.....	78
Environmental control.....	11
Equipment and materials.....	80
Equipment assembly/disassembly.....	22
Equipment fault isolation and correction.....	17
Equipment required.....	49
Equipment required but not supplied.....	78
Equipment supplied.....	77
Estimated cost of repair.....	73
Explanatory text.....	6
Exploded views.....	6
External component preparation.....	70
Extreme weather maintenance.....	19

F

Fabrication.....	21
Facilities and equipment.....	73
Facility description and purpose.....	77
Facility title.....	77
Fault isolation (troubleshooting).....	20
Fault isolation loops.....	57
Figure of depth of penetration.....	47
Figure of exposure correction.....	47
Figure of radiographs.....	47
Filling.....	71
Finish system table and illustrations.....	44
Fire.....	62
First aid.....	70
Fluorescent penetrant.....	49
Foldout pages and illustrations.....	46
Follow-on maintenance.....	22
Foreword.....	13
Foreword WP.....	10, 47, 52, 54, 77
Foreword/System Description WP (WP 010 00).....	61
Format.....	23
Front matter.....	9, 60
Functional divisions.....	19

G

General.....	1, 72
General information.....	10

MIL-DTL-87929D

General NDI equipment setup procedures.....	49
General requirements.....	2
General safety requirements.....	38
General series technical orders.....	44
General Work Package (WP)/Subordinate Work Package (SWP) requirements.....	59
General WP/SWP requirements.....	3
Geographical.....	78
Government documents.....	1, 40, 45, 51, 54, 58, 72, 76

H

Hand-held flight computer operation instructions.....	75
Handling.....	16, 64
Handling, transportation, and inspection WP.....	38
Hazardous materials.....	62
Humidity indicator inspection cycle.....	66

I

Identical test setup.....	20
Identification.....	76
Illustrated Parts Breakdown (IPB) WP.....	14
Illustrated Parts Breakdown SWPs.....	69
Illustrated Parts Breakdown WP (WP 998 00).....	68
Illustrated support equipment.....	13
Illustration keys.....	6
Illustrations.....	5, 42, 46, 75, 77
Illustrations and tables for corrosion prone areas.....	42
Illustrations used for more than one inspection.....	46
Improper use of tools.....	62
In-process inspection.....	19
Inside plant.....	78
Inspection - components SWPs.....	66
Inspection evaluation.....	66
Inspection illustrations.....	6
Inspection or damage requirements.....	16
Inspection or damage terms.....	15
Inspection periods.....	73
Inspection prior to packing.....	73
Inspection requirements.....	18
Inspection Requirements and Procedures WP (WP 050 00).....	64
Inspection requirements column.....	18
Inspection tables.....	23
Inspection WP.....	72
Inspections.....	17
Installation drawings.....	81
Installation instructions.....	80
Installation of hardware.....	22
Installation WP.....	80
Installation-engineering drawings.....	80
Installation-Engineering Facility (for Ground C-E Equipment) Manual.....	76
Instructions.....	46
Instructions for disposition of rejected items.....	66
Instrumented NDI procedure illustrations.....	46
Intended use.....	26

MIL-DTL-87929D

Interaction with other programs.....	52
Interconnection cable diagrams.....	7
Interconnections.....	6
Intermediate maintenance manual.....	2
Internal component preparation.....	70
Interpretation of test results.....	56
(Interval) day periodic complete inspection.....	73
(Interval) day periodic external inspection.....	73

L

Layout planning.....	79
Leading particulars.....	77
Line art.....	5
Local manufacture of tools/equipment.....	12
Logic diagrams.....	7
Logistic.....	78
Lubrication.....	21

M

Magnetic particle.....	49
Maintenance.....	19, 67, 71
Maintenance concept.....	11
Maintenance manuals.....	2
Maintenance SWPs.....	68
Maintenance WP (WP 070 00).....	67, 71
Major leaks in CMBR agent items.....	70
Major test points.....	8
Malfunction isolation.....	56
Man-minutes column.....	18
Manpower requirements.....	81
Manual arrangement.....	8, 60
Manual set.....	3
Manual set arrangement.....	9
Marking and stenciling.....	22
Marking illustrations.....	44
Markings.....	61
Master list of consumables.....	12, 63
Master list of containers.....	12
Master list of safety and protective devices.....	63
Master list of special tools.....	11, 63
Master list of special tools, test equipment, and consumables WP.....	11, 47, 77
Master list of special tools, test equipment, computer software, and consumables WP.....	55
Master list of support equipment.....	63
Master list of test equipment.....	11, 63
Master Lists of Special Tools Equipment, and Consumables WP (WP 030 00).....	62
Minor leaks in CMBR agent items.....	70
Minor test points.....	8
Module schematic diagrams.....	7
More than one defect.....	50

N

NDI equipment setup/standardization.....	49
NDI equipment technical manuals.....	47

MIL-DTL-87929D

NDI inspection safety	46
New materials	41
Nomenclature.....	4
Non-government publications.....	45, 51, 54, 59, 72, 76
Non-government standards and other publications.....	40, 45, 51, 54, 59, 72, 76
Nondestructive Inspection (NDI).....	18
Nondestructive inspection (NDI) manual.....	46
Nonnuclear munitions.....	28
Notes.....	28
Numbering of added material.....	4
Numbering of added WP/SWPs.....	4
Numbering of figures, tables, and pages.....	4
Numbering of WP/SWPs.....	3
Numerical Index of Effective Work Packages.....	9

O

Obtaining files with a .mil address.....	32
Obtaining files without a .mil address	32
On-condition maintenance.....	22
On-condition maintenance instruction manual (engines only).....	3
Operating procedures WP.....	36
Operation.....	17
Operation and maintenance instruction manual.....	3
Operation WP.....	75
Operational.....	81
Operational checkout.....	22
Operator inspection.....	17
Operator intervention.....	56
Operator maintenance and servicing.....	17
Operator participation.....	55
Order of precedence.....	2
Organizational maintenance manual.....	2
Other Government documents, drawings, and publications.....	2, 40, 45, 51, 58, 72, 76
Other inspections	65
Outside plant.....	79
Overall schematic diagrams.....	7

P

Packaging.....	26, 66
Packing.....	73
Packing procedures WP.....	73
Paint removal and painting WP.....	41
Painting and markings	68
Parachute packing procedures manual.....	72
Paragraphs.....	4
Parts description.....	49
Periodic and special inspection.....	17
Periodic inspection (PI).....	65
Piping and clamping	21
Postfire inspection WP.....	39
Postoperative Procedures WP.....	37
Power and control schematics.....	7
Power requirements	79

MIL-DTL-87929D

Pre-shakedown.....	81
Prefire facility preparation WP.....	39
Preflight inspection.....	73
Prefunctional check (electrical).....	19
Preissue inspection (PII).....	65
Preoperative procedures WP.....	35
Preparation.....	40, 52, 75-76
Preparation for firing WP.....	39
Preparation for maintenance.....	19
Preparation for shipment and storage.....	23
Preparation for storage.....	70
Preparation for testing.....	56
Preparation for use.....	67, 71
Preparation of part for inspection.....	49
Preparation, sampling, and testing of decontamination solution.....	70
Preservation and packing.....	23
Priority of issue.....	65
Procedural illustrations.....	5
Program objectives.....	52
Programmed Depot Maintenance (PDM).....	23
Propellant characteristics and safety precautions.....	16
Proprietary processes.....	19
Purpose.....	40, 54

R

Radiographic.....	49
Receiving and handling.....	15
Receiving inspection.....	15
Receiving inspection (RI).....	65
Records/documentation.....	69
Reference material required.....	13
References.....	5, 46
Related maintenance manuals.....	46
Removal/replacement.....	68
Repair and replacement.....	21
Repair illustrations.....	6
Repair kits.....	21
Repair of special tools and test equipment.....	12
Repair procedures WP.....	73
Repetitive NDI procedures WP.....	48
Repetitive procedures.....	49
Replacement.....	28
Replacement schedule.....	22
Required conditions.....	20
Returned munitions inspection (RMI).....	65
Routine visual inspections.....	46

S

Safe for maintenance.....	49
Safety Summary and Accident Prevention WP (WP 020 00).....	61, 69
Sampling inspection.....	18
Scheduled maintenance.....	22
Schematic diagram general requirements.....	6

MIL-DTL-87929D

Schematic diagrams	6
Schematic diagrams for equipment.....	6
Scope.....	1, 32–33, 35, 38, 40, 45, 51, 54, 58, 72, 75–76
Sealant repair table.....	43
Sealing WP	41
Seam and area taping.....	70
Secondary test points	8
Separate manual.....	69
Sequence	46
Sequence of operations	67
Servicing.....	16, 22, 68
SFEL	82
SGML document type definition	37, 39, 44, 50, 52, 57, 71, 74–75, 82
Shakedown.....	81
Shipping and storage.....	24
Shipping inspection (SI)	65
Site	82
Siting considerations.....	78
Size of manuals.....	2
Special containers	28
Special inspections (SPI).....	65
Special materials.....	44
Special or proprietary equipment or processes.....	41
Special packing.....	24
Special technical manuals.....	3
Special technical manuals development.....	25
Special WPs.....	41
Specialized Storage and Handling.....	64
Specialized storage and maintenance procedures; AUR munitions and associated support equipment, conventional components, and CMBR agents.....	59
Specific NDI method.....	49
Specific part/component illustration.....	46
Specifications, standards and handbooks.....	45, 58
Specifications, standards, and handbooks.....	1, 40, 51, 72
Static firing of missile motors manua.....	38
Stating requirements.....	17
Storage and Handling Requirements WP (WP 040 00).....	63, 70
Storage data.....	64
Storage inspection.....	24
Storage monitoring inspection (SMI).....	65
Storage requirements	64
Subfunctions	19
Subject term (key word) listing.....	29
Supplies.....	49
Supporting structures.....	78
SWP 01, General.....	48
SWP 02, NDI equipment setup.....	48
SWP 03, Fluorescent penetrant procedures	48
SWP 04, Radiographic procedures	48
SWP 05, Magnetic particle procedures.....	48
SWP 06, Ultrasonic procedures.....	48
SWP 07, Eddy current procedures.....	48
SWP 08, Other NDI procedures.....	48
SWP description	3

MIL-DTL-87929D

Symbols	6
Symptoms	70
System.....	82
System peculiar.....	44
System Peculiar Corrosion Control Manual.....	40
System peculiar NDI.....	46
System securing.....	50

T

Table for station utilization.....	55
Table of bare aluminum alloy conductivity acceptance values	47
Table of clad aluminum alloy sheet conductivity acceptance values	47
Table of leading characteristics.....	61
Table of limits	13
Table of use and applicability	55
Tables.....	77
Tag description table.....	44, 50, 53, 57, 71, 74–75, 82
Tag Description Table (TDT).....	32, 37, 39
Tasks	52
Technical manual	28
Technical procedures	13
Technical WP/SWP.....	12
Technical WP/SWP development.....	14
Terminal resistance diagrams.....	7
Terminal voltage diagrams.....	7
Termination and restart.....	56
Test data	20
Test Diagrams (TDM).....	57
Test equipment.....	20
Test evaluation	69
Test operations and motor firing WP.....	39
Test point identification.....	7
Test points	57
Test procedures WP.....	56
Test sequence	82
Test setup diagrams.....	56
Test start.....	56
Test WP.....	81
Testing.....	22, 73
Testing and reprogramming procedures.....	69
Testing facility WP	35
Testing procedures	56
Testing procedures manual	35
Testing/Reprogramming WP (WP 080 00).....	69
Text content.....	4, 75
Theory of operation.....	19
This section is not applicable to this appendix	33
Title.....	49
TMSS Community of Practice (CoP).....	32
TMSS support.....	32
TMSS web site.....	32
Torque requirements table.....	67
Trouble analysis WP.....	36

MIL-DTL-87929D

Type of inspection column.....	18
Types of inspections.....	65

U

Ultrasonic.....	49
Unpacking.....	15, 66
Unpacking and Packaging SWPs.....	67
Unpacking and Packaging WP (WP 060 00).....	66
Unpacking, inspection, and assembly.....	69
Use of NDI standards.....	49

V

Verification.....	28
Verification requirements.....	25
Visual inspection.....	18

W

Warhead data.....	13
Warnings.....	28
Warranty provisions.....	11
Waveform diagrams.....	7
WP 005 and subsequent WP/SWPs.....	48
WP concept.....	26
WP coverage.....	3
WP description.....	3
WP/SWP arrangement.....	10, 60
WP/SWP Numbering System.....	60

MIL-DTL-87929D

CONCLUDING MATERIAL

Custodians:
Air Force - 16

Preparing activity:
Air Force - 16
(Project TMSS-2011-017)

Review activities:
Air Force - 10, 99

NOTE

The activities listed above were interested in this document as of the date of this document. Since organizations and responsibilities can change, you should verify the currency of the information above using the ASSIST Online database at <https://assist.daps.dla.mil>.