

INCH-POUND

MIL-DTL-8777E
21 May 2007
SUPERSEDING
MIL-DTL-8777D
5 July 2002

DETAIL SPECIFICATION
WIRE, ELECTRICAL, SILICONE-INSULATED,
COPPER, 600-VOLT, 200°C

Inactive for new design after 01 June 1998

This specification is approved for use by all Departments
and Agencies of the Department of Defense.

1. SCOPE

1.1 Scope. This specification covers single conductor wire with a silicone primary insulation capable of continuous operation at 600 volts and a maximum conductor temperature of 200°C (392°F). These wires are suitable for use in aircraft and missiles using any combination of electrical loading and ambient temperature, provided the maximum conductor temperature is not exceeded. The wires covered by this specification are not intended as fire-resistant wires.

1.2 Classification. Single conductor insulated wire as specified in the applicable MS sheet (see 6.2).

2. APPLICABLE DOCUMENTS

2.1 General. The documents listed in this section are specified in sections 3, 4, or 5 of this specification. This section does not include documents cited in other sections of this specification or recommended for additional information or as examples. While every effort has been made to ensure the completeness of this list, document users are cautioned that they must meet all specified requirements of documents cited in sections 3, 4, or 5 of this specification, whether or not they are listed.

2.2 Government documents.

2.2.1 Specifications and standards and handbooks. The following specifications, standards and handbooks form a part of this document to the extent specified herein. Unless otherwise specified, the issues of these documents are those cited in the solicitation or contract.

Comments, suggestions, or questions on this document should be addressed to Defense Supply Center, Columbus, ATTN: DSCC-VAI, P.O. Box 3990, Columbus, OH 43218-3990, or email to WireCable@dsc.dla.mil. Since contact information can change, you may want to verify the currency of this address information using the ASSIST Online database at <http://assist.daps.dla.mil>.

MIL-DTL-8777E

COMMERCIAL ITEM DESCRIPTION

A-A-59551 - Wire, Electrical, Copper.

FEDERAL SPECIFICATION

TT-I-735 - Isopropyl Alcohol.

FEDERAL STANDARD

FED-STD-228 - Cable and Wire, Insulated; Methods of Testing.

DEPARTMENT OF DEFENSE SPECIFICATIONS

MIL-W-5088 - Wiring, Aerospace Vehicle.
MIL-PRF-5606 - Hydraulic Fluid, Petroleum Base, Aircraft, Missile, and Ordnance.
MIL-DTL-5624 - Turbine Fuel, Aviation Grades JP-4, JP-5, and JP-5/JP-8 ST.
MIL-PRF-7808 - Lubricating Oil, Aircraft Turbine Engine, Synthetic Base.

DEPARTMENT OF DEFENSE STANDARDS

MIL-STD-104 - Limits for Electrical Insulation Color.
MIL-STD-129 - Military Marking.
MS25471 - Wire, Electrical – Silicone-Insulated, Copper, 600 Volt, 200°C, Polyester Jacket.
MS27110 - Wire, Electrical – Silicone-Insulated, Copper, 600 Volt, 200°C, FEP Jacket.

(Copies of these documents are available online at <http://assist.daps.dla.mil> or <http://assist.daps.dla.mil/quicksearch/> or from the Standardization Document Order Desk, Building 4D, 700 Robbins Avenue, Philadelphia, PA 19111-5094.)

2.3 Non-Government publications. The following documents form a part of this document to the extent specified herein. Unless otherwise specified, the documents are the issues of the documents cited in the solicitation or contract (see 6.2).

ASTM INTERNATIONAL

ASTM B298 - Wire, Copper, Silver-Coated Soft or Annealed.

(Copies of these documents are available online at <http://www.astm.org> or from the ASTM International, P.O. Box C700, 100 Barr Harbor Drive, West Conshohocken, PA 19428-2959.)

GRETAG MACBETH, LLC

Munsell Book of Color

(Copies of this document are available online at www.gretagmacbeth.com or requested from Gretag Macbeth, 617 Little Britain Road, New Windsor, NY 12553-6148)

MIL-DTL-8777E

NCSL INTERNATIONAL

NCSL-Z540.1 Calibration Laboratories and Measuring and Test Equipment,
General Requirements

(Copies of these documents are available online at <http://www.ncsli.org> or from NCSL International
2995 Wilderness Place, Suite 107 Boulder, Colorado 80301-5404.)

SAE INTERNATIONAL

SAE AS1241 - Fire Resistant Phosphate Ester Hydraulic Fluid for Aircraft

(Copies of these documents are available online at <http://www.sae.org> or from the SAE World
Headquarters, 400 Commonwealth Drive, Warrendale, PA 15096-0001.)

2.4 Order of precedence. In event of a conflict between the text of this document and the references cited herein (except for related specification sheets), the text of this document takes precedence. Nothing in this document, however, supersedes applicable laws and regulations unless a specific exemption has been obtained.

3. REQUIREMENTS

3.1 Specification sheets. The individual item requirements shall be as specified herein and as specified in the applicable specification sheet. In the event of any conflict between the requirements of this specification and the specification sheet, the latter shall govern.

3.2 Qualification. Wires furnished under this specification shall be products that are authorized by the qualifying activity for listing on the applicable qualified products list (QPL) before contract award (see 4.6 and 6.3).

3.3 Materials. The materials for the principal components of the wire shall be as specified herein. Prior approval to use substitute material must be obtained from the qualifying activity. When a definite material is not specified, a material shall be used that will enable the finished products to meet the performance requirements of this specification. Acceptance or approval of any constituent material shall not be construed as a guaranty of the acceptance of the finished product. All materials used in the manufacture of wires furnished hereunder shall be of such quality and form that the finished product conforms to the requirements of this specification. All materials used shall conform to the requirements specified herein.

3.3.1 Recycled, recovered, or environmentally preferable materials. Recycled, recovered, or environmentally preferable materials should be used to the maximum extent possible, provided that the material meets or exceeds the operational and maintenance requirements, and promotes economically advantageous life-cycle costs.

3.3.2 Conductor material. Strands used in the manufacture of conductors shall be annealed or soft drawn copper wire from the best obtainable, commercially pure wire bars, and as specified in [A-A-59551](#).

MIL-DTL-8777E

3.3.3 Insulating materials.

3.3.3.1 Primary insulation. The primary insulation shall be of silicone rubber, applied by extrusion or taping. If a silicone rubber tape is used, it shall be fused into a homogeneous mass.

3.3.3.2 Inner braid. The inner braid shall consist of glass fibers or a combination of glass fibers and polyester fibers covering the primary insulation. The inner braid shall be treated with a heat-resistant finisher.

3.3.3.3 Outer jacket. The outer jacket shall be as specified in the applicable MS sheet.

3.4 Design and construction.

3.4.1 Conductors.

3.4.1.1 Conductor coating. Individual strands shall be uniformly coated with a smooth continuous layer of commercially pure silver having a minimum thickness of 40 micro inches when tested as specified in 4.6.2.2. Following the continuity of coating test in 4.6.2.1, there shall be no evidence of exposed copper.

3.4.1.2 Stranding.

3.4.1.2.1 Concentric-lay. Wire sizes 22 through 12 shall be constructed with concentric-lay conductors and as specified in table I. Concentric-lay shall be interpreted to be a central core surrounded by one or more layers of helically wound strands. It is optional for the direction of lay for successive layers to be alternately reversed (true concentric-lay) or to be in the same direction (unidirectional lay). When unidirectional lay is used, the strands shall be assembled in a geometric arrangement of concentric layers, so as to produce a smooth and uniform conductor, circular in cross-section and free of any crossovers, high strands or other irregularities. The direction of lay of individual strands in the outer layer of the concentrically stranded conductors of finished wire shall be left hand. The length of lay in the outer layer shall be not less than 8 nor more than 16 times the maximum conductor diameter specified in the applicable MS sheet.

3.4.1.2.2 Rope lay. Wire sizes 10 through 00 shall be rope lay and as specified in table I and as follows:

- a. Rope lay stranded conductors shall be laid up concentrically with a center core surrounded by one or more helically wound members. It is optional for the direction of lay for successive layers to be alternately reversed (true concentric-lay) or to be in the same direction (unidirectional lay). The length of lay of the outer layer of rope lay stranded members forming the conductor shall be not less than 10 nor more than 14 times the outside diameter of the completed conductor. The direction of lay of the outside layer may be either left or right hand.
- b. Members of rope lay stranded conductors: The length of lay of the conductors composing the stranded members shall be not greater than 16 times the outside diameter of the member. Stranding of the individual members may be concentric or bunch.

MIL-DTL-8777E

TABLE I. Wire construction details.

Wire size	Nominal CMA ^{1/} of conductor (circular mils)	Number of strands	Allowable number of missing strands	Nominal diameter of individual strands inch/(mm)	Maximum diameter of stranded conductor inch/(mm)	Maximum resistance at 20°C (68°F) (Ω/1,000 ft.)
22	755	19	0	0.0063 (.16)	0.033 (.84)	15.2
20	1,200	19	0	.0079 (.20)	.041 (1.04)	9.42
18	1,909	19	0	.0100 (.25)	.052 (1.32)	6.03
16	2,409	19	0	.0113 (.29)	.060 (1.52)	4.72
14	3,830	19	0	.0142 (.36)	.074 (1.88)	2.99
12	6,088	19	0	.0179 (.45)	.093 (2.36)	1.88
10	9,880	49	0	.0142 (.36)	.128 (3.25)	1.16
8	16,864	133	0	.0113 (.29)	.176 (4.47)	0.70
6	26,813	133	0	.0142 (.36)	.218 (5.54)	0.436
4	42,613	133	0	.0179 (.45)	.272 (6.91)	0.274
2	66,832	665	2	.0100 (.25)	.345 (8.76)	0.179
1	82,108	817	2	.0100 (.25)	.384 (9.75)	0.144
0	105,022	1,045	3	.0100 (.25)	.432 (10.97)	0.114
00	133,665	1,330	3	.0100 (.25)	.490 (12.45)	0.090

^{1/} Circular Mil Area (CMA)

3.4.1.3 Splices. Splices in individual strands shall be butt-brazed. Individual brazed splices in any section of the conductor shall not occur closer together than 10 feet. Splices in any individual stranded member, in rope-lay construction, shall be so finished off that the conductor diameter is not increased at the point of brazing. In no case shall the whole conductor be spliced at one point.

3.4.1.4 Elongation. When tested as specified in 4.6.2.3, the individual strands from the conductor of the finished wire shall withstand an elongation of 10 percent before breaking.

3.4.1.5 Conductor diameter. The diameter of the conductor of the finished wire shall be as specified in table I.

3.4.2 Insulation.

3.4.2.1 Concentricity. The primary insulation shall be formed concentrically around the conductor. When measured as specified in 4.6.3.1, the concentricity shall be not less than 70%.

3.4.2.2 Physical properties. When tested separately as specified in 4.6.3.2.1, the physical properties of extruded primary insulation shall be not less than specified in the applicable MS sheet.

3.4.2.2.1 Physical properties after aging. When tested as specified in 4.6.3.2.2, extruded primary insulation removed from finished wire shall have physical properties not less than the values specified for aged samples in the applicable MS sheet.

3.4.2.3 Primary insulation flaws. After application of the primary insulation, and prior to the application of any other material, all of the wire shall pass the test specified in 4.6.3.3 without failure.

3.4.3 Finished wire.

MIL-DTL-8777E

3.4.3.1 Finished wire diameter. The diameter of the finished wire shall be as specified in the applicable MS sheet.

3.4.3.2 Finished wire weight. When tested as specified in 4.6.4.14, the weight of the finished wire shall be not greater than the values specified in the applicable MS sheet.

3.4.3.3 Wire outer surface. The outer surface of the wire shall be non-corrosive and flexible, and shall be finished smooth. The multiple layers of braided material, used as the outer covering, shall be bonded together by the heat-resistant finisher to prevent fraying. Adjacent layers of wire, when wound on a reel, shall not stick to one another at any temperature under 200°C.

3.4.3.4 Color. The color shall be black or white as specified in MIL-STD-104, or tan as specified in the following limits as defined by the Munsell Book of Color:

Hue	-	Red limit – 10R
Hue	-	Green limit – 5Y
Value	-	Not less than 6.0 (dark limit)
Chroma	-	Not greater than 8.0 (saturation limit)

The above color requirements shall also apply after the test specified in 4.6.4.3.1.

3.4.4 Performance.

3.4.4.1 Conductor resistance. When tested as specified in 4.6.4.1, the conductor resistance of the finished wire shall be as specified in table I.

3.4.4.2 Finished wire flaw test. All of the finished wire shall conform to the test specified in 4.6.4.2 without electrical breakdown.

3.4.4.3 Life cycle. Following the tests specified in 4.6.4.3.1 and 4.6.4.3.2, there should be no cracking of the outer surface or of the primary insulation as viewed visually without magnification. The test specimen shall then conform to the test specified in 4.6.4.3.3 without electrical breakdown or flashover. The insulation shall not cause pitting of the conductor during the test specified in 4.6.4.3.4.

3.4.4.4 Cold bend. The wire shall withstand the test in 4.6.4.4 without cracking the outer surface or primary insulation when viewed visually without magnification. The test specimen shall then pass the test specified in 4.6.4.3.3 without breakdown or flashover.

3.4.4.5 Oil absorption. After having been subjected to the test specified in 4.6.4.5, the increase in diameter shall not exceed 5 percent. The insulation shall show no evidence of coming through the outer cover. The test specimen shall then withstand the tests specified in 4.6.4.3.2 and 4.6.4.3.3 without electrical breakdown or flashover.

3.4.4.6 Immersion. Following the test specified in 4.6.4.6, the increase in diameter shall not exceed 5 percent. The insulation shall show no evidence of coming through the outer cover. The test specimen shall then withstand the test specified in 4.6.4.3.3 without electrical breakdown.

3.4.4.7 High temperature endurance. Following the test specified in 4.6.4.7, the test specimen shall withstand the tests specified in 4.6.4.4, 4.6.4.5, and 4.6.4.3.3 without electrical breakdown or flashover. Discoloration of the silver surface shall not be cause for rejection.

MIL-DTL-8777E

3.4.4.8 Flammability. The wire shall withstand the test specified in 4.6.4.8.2 without electrical breakdown. The wire shall withstand the test specified in 4.6.4.8.3, during which the flame rate of travel along the wire shall not exceed 3 inches per minute, and the wire shall be self-extinguishing within 30 seconds after removal of the flame. Burning particles or drippings shall not cause the tissue paper to burst into flames. Charred holes or spots in the tissue paper shall not constitute failure.

3.4.4.9 Abrasion resistance. All wire shall meet the minimum requirements specified in the applicable MS sheet, when tested as specified in 4.6.4.9. Following immersion in the fluid specified in 4.6.4.6, the wire shall have not less than 70 percent of the abrasion resistance specified in the applicable MS sheet.

3.4.4.10 Humidity resistance. When tested as specified in 4.6.4.10, sizes 22 through 12 of the finished wire shall have a humidity resistance as specified in the applicable MS sheet.

3.4.4.11 Insulation resistance. When tested as specified in 4.6.4.11, sizes 22 through 12 of the finished wire shall have an insulation resistance as specified in the applicable MS sheet.

3.4.4.12 Surface resistance. When tested as specified in 4.6.4.12, sizes 22 through 12 of the finished wire shall have a computed resistance as specified in the applicable MS sheet. Following the application of a potential of 2,500 volts rms, 60 hertz, there shall be no evidence of distress, such as arcing, smoking, burning, flashover, or dielectric failures.

3.4.4.13 Smoke. When tested as specified in 4.6.4.13, the finished wire shall not give off visible smoke.

3.4.4.14 Thermal shock resistance. When tested as specified in 4.6.4.15, the insulation layer, or layers, shall not exhibit shrinkage or expansion greater than 0.06 inch (1.52 mm). Flaring (separation of adjacent layers) shall also constitute failure.

3.4.4.15 Stripping. The insulation of the finished wire shall be readily removable by wire-stripping devices.

3.5 Marking. The finished wire shall be identified by a printed marking applied to the outer surface or visible through the outer surface. The printed identification shall consist of the following, at intervals of 9 inches (228.60 mm) to 60 inches (1524.00 mm), as measured from the end of one complete marking to the beginning of the succeeding complete marking:

- a. MS or specification sheet Part or Identifying Number (PIN).
- b. Manufacturer's Commercial and Government Entity (CAGE) code.

The printing shall be green in color as specified in MIL-STD-104, class 1. Identification printing shall be applied with the vertical axis of the printed characters lengthwise of the wire when the nominal diameter of the finished wire is .050 inch (1.27 mm) or smaller. The vertical axis of the printed characters may be either crosswise or lengthwise of the wire when the nominal diameter of the wire exceeds 050 inch (1.27 mm). All printed characters shall be complete and legible.

3.5.1 Marking durability. Identification printing shall be capable of withstanding repeated abrasions of the durability test as specified in 4.6.4.16. Marking durability is not applicable when printing is under a clear jacket, if used.

3.6 Workmanship. The wire shall be constructed and finished as specified in high-grade cable production techniques. The wire shall be free from lumps, kinks, splits, abrasions, scraped or corroded

MIL-DTL-8777E

surfaces, and skin impurities. The wire shall be a uniform and consistent product and shall be free from defects that adversely affect the serviceability of the product.

4. VERIFICATION

4.1 Classification of inspections. The inspection requirements specified herein are classified as follows:

- a. Qualification inspection (see [4.3](#)).
- b. Conformance inspection (see [4.4](#)).

4.2 Test equipment and inspection facilities. Test and measuring equipment and inspection facilities of sufficient accuracy, quality, and quantity to permit performance of the required inspection shall be established and maintained by the contractor. The establishment and maintenance of a calibration system to control the accuracy of the measuring and test equipment [e.g., non-Government standard (NGS) or federal or military standard] shall be as specified in [NCSL-Z540.1](#) or equivalent.

4.2.1 Test conditions. Unless otherwise specified in the method, all inspections shall be performed as specified in the test conditions specified in the applicable section of [FED-STD-228](#).

4.3 Qualification inspection. Qualification inspection shall consist of all the qualification tests and inspections in [table II](#).

4.3.1 Qualification samples. Finished wire samples of the following lengths shall be selected for qualification inspection. A length of 2 linear feet of the coated conductor used in the manufacture of the finished wire sample shall be included with the wire sample. When approved, wire sizes 20 will qualify wire sizes 22, 20, and 18; wire size 14 will qualify wire sizes 16, 14, and 12; wire size 8 will qualify wire sizes 10, 8, and 6; and wire size 0 will qualify wires sizes 4 through 00.

<u>Wire size range (AWG)</u>	<u>Required length of wire sample (feet)</u>
20 and 14	150
8 and 0	100

MIL-DTL-8777E

TABLE II. Qualification inspections.

Inspection or test	Requirement	Method
Visual and mechanical examination	3.1, 3.3 thru 3.4.1.3, 3.4.1.5, thru 3.4.3.4, 3.4.4.15, 3.5, and 3.6	4.6.1
Continuity of coating	3.4.1.1	4.6.2.1
Thickness of coating	3.4.1.1	4.6.2.2
Conductor elongation	3.4.1.4	4.6.2.3
Concentricity	3.4.2.1	4.6.3.1
Tensile strength and elongation	3.4.2.2	4.6.3.2.1
Aging	3.4.2.2.1	4.6.3.2.2
Primary insulation flaws	3.4.2.3	4.6.3.3
Conductor resistance	3.4.4.1	4.6.4.1
Finished wire flaws	3.4.4.2	4.6.4.2
Life cycle	3.4.4.3	4.6.4.3
Cold bend	3.4.4.4	4.6.4.4
Oil absorption	3.4.4.5	4.6.4.5
Immersion	3.4.4.6	4.6.4.6
High temperature endurance	3.4.4.7	4.6.4.7
Flammability	3.4.4.8	4.6.4.8
Abrasion	3.4.4.9	4.6.4.9
Humidity resistance	3.4.4.10	4.6.4.10
Insulation resistance	3.4.4.11	4.6.4.11
Surface resistance	3.4.4.12	4.6.4.12
Smoke	3.4.4.13	4.6.4.13
Wire weight	3.4.3.2	4.6.4.14
Thermal shock resistance	3.4.4.14	4.6.4.15
Marking durability	3.5.1	4.6.4.16

4.3.2 Retention of qualification. To retain qualification, the contractor shall report at two-year intervals to the qualifying activity. The qualifying activity will establish the initial reporting date. The report shall consist of:

- a. A summary of the results of the tests performed for inspection of product for delivery, indicating as a minimum the number of lots that have passed, the number that have failed, and the groups which have failed. The results of tests of all reworked lots shall be identified and accounted for.
- b. A summary of the results of tests performed for conformance inspection, including the number and mode of failures. The summary shall include results of all conformance tests performed and completed during the two-year period. If the summary of the tests results indicates nonconformance with specification requirements, and corrective action acceptable to the qualifying activity has not been taken, action may be taken to remove the failing product from the QPL.

MIL-DTL-8777E

Failure to submit the report within 30 days after the end of each two-year period may result in loss of qualification for the product. In addition to the periodic submission of inspection data, the contractor shall immediately notify the qualifying activity at any time during the two-year period that the inspection data indicates failure of the qualified product to meet the requirements of this specification.

In the event that no production occurred during the reporting period, a report shall be submitted certifying that the company still has the capabilities and facilities necessary to produce the item. If during two consecutive reporting periods there has been no production, the manufacturer may be required, at the discretion of the qualifying activity, to submit his qualified products to retesting as specified in the qualification inspection requirements and the reason for no production.

4.4 Conformance inspection. Conformance inspection shall consist of all the conformance tests and inspections in table III.

TABLE III. Conformance inspections.

Inspection or test	Requirement	Method
Group I		
Stranding	3.3.1 and 3.4.1	4.6.1
Wire outer surface	3.4.3.3	4.6.1
Wire diameter	3.4.3.1	4.6.1
Conductor diameter	Table I	4.6.1
Finished wire weight	3.4.3.2	4.6.4.14
Marking	3.5	4.6.1
Elongation (copper conductor)	3.4.1.4	4.6.2.3
Concentricity	3.4.2.1	4.6.3.1
Group II		
Physical properties (primary insulation)	3.4.2.2	4.6.3.2.1
Aging (except oxidation)	3.4.2.2.1	4.6.3.2.2
Cold bend	3.4.4.4	4.6.4.4
Oil absorption	3.4.4.5	4.6.4.5
Abrasion (procedure I only)	3.4.4.9	4.6.4.9.1
Flammability (procedure II only)	3.4.4.8	4.6.4.8.3
Smoke	3.4.4.13	4.6.4.13
Thermal shock resistance	3.4.4.14	4.6.4.15

4.4.1 Sampling. For groups I and II tests, a random sample of the size specified shall be selected from an inspection lot. From each sample unit, specimens of sufficient length shall be selected for the specified tests. The sample size shall be based on the inspection lot size as specified in table IV.

MIL-DTL-8777E

TABLE IV. Inspection sample.

Inspection lot size <u>1/</u>	Sample size
1	1
2 to 8	2
9 to 90	3
91 to 150	12
151 to 300	19

1/ Lot size is based on the number of units of product (reels, spools, or coils) (see 4.4.2.1 and 4.4.2.2).

4.4.2 Interpretation of terms. Terms and definitions used for sampling and inspections herein shall be as specified in the following:

4.4.2.1 Inspection lot. An inspection lot shall consist of all wire of the same PIN, produced under essentially the same conditions on the same machine that is presented for inspection and shipment at one time. For this specification, an inspection lot shall not exceed 1,000,000 feet, or 1 week's production, whichever is less. The inspection lot shall be expressed in units of thousands of feet (total footage in inspection lot divided by 1,000).

4.4.2.2 Unit of product. The unit of product for determining lot size under this specification shall be the quantity of continuous length of wire on one coil, reel, or spool, as applicable.

4.4.2.3 Sample. A sample shall consist of a group of individual lengths of wire chosen at random from the inspection lot.

4.4.2.4 Sample unit. A sample unit shall consist of one of the individual lengths of the sample. Each sample unit shall be of sufficient length to permit all applicable inspections and tests. Not more than one sample unit shall be taken from a single unit of product.

4.4.2.5 Specimen. A specimen is a portion of finished wire taken from the sample unit for the performance of a particular inspection or test.

4.4.3 Specimen length. Each specimen for inspection shall be of the length specified in the applicable test method.

4.4.4 Rejected lots. Failure of any sample to pass conformance inspections shall constitute a failure of the lot. If an inspection lot is rejected, the contractor may rework the lot to correct the defects or screen out the defective units, and resubmit the lot for re-inspection. Such lots shall be separated from new lots and shall be identified as re-inspected lots.

4.4.5 Noncompliance. If a sample fails to pass conformance inspections, the contractor should notify the cognizant inspection activity of such failure and take corrective action on the materials, processes, or both, as warranted, on all units of the product. Acceptance and shipment of the product will be discontinued until corrective action acceptable to the inspection activity has been taken. After the corrective action has been taken, the conformance inspection shall be repeated on replacement articles. (This includes all test and examinations, or only the test that the original sample failed, at the option of the inspection activity.) Final acceptance and shipment will be withheld until the conformance inspection has

MIL-DTL-8777E

shown that the corrective action was successful. In the event of failure after re-inspection, information concerning the failure should be provided to the cognizant inspection activity.

4.5 Process control inspections. These inspections are of such a nature that either they cannot be performed on the finished wire or do not lend themselves to statistical plans because the total length of wire is exposed to the inspection. Therefore, these inspections must be performed during the most appropriate stage of the manufacturing operations. The process control inspections shall consist of the inspections specified in table V.

TABLE V. Process control inspections.

Inspection or test	Requirement	Method
Coating continuity	3.4.1.1	4.6.2.1
Conductor material	3.4.1.2	4.6.2
Splices	3.4.1.3	4.6.1
Primary insulation flaws	3.4.2.3	4.6.3.3
Finished insulation flaws	3.4.4.2	4.6.4.2

4.5.1 Sampling.

4.5.1.1 Conductor material. From each week's production of individual strands or from every 1,000 pounds of finished strand, whichever is less, three 10-foot lengths of strand shall be selected in such a manner as to be representative of the material to be used in the finished insulated wire.

4.5.1.2 Splices. The manufacturer's method of splicing individual strands and members shall be observed at random intervals not exceeding 1 week.

4.5.1.3 Coating. The sample shall consist of not less than 3.5 feet of silver-coated strand, before stranding, which is representative of the strand unused in the manufacture of each inspection lot of finished wire (see 4.5.1.1).

4.5.2 Rejection and retest. When the sample selected from a production run fails to meet the specified test, no items still on hand or later produced shall be accepted until the extent and cause of the failure has been determined. After investigation, the contractor shall advise the procuring activity of the action taken and, after corrections have been made, shall repeat all the process control tests. Rejection after corrective action will require that the contractor advise the procuring activity of the details surrounding the retest and cause for rejection.

4.6 Methods of inspection and test.

4.6.1 Visual and mechanical examination. All samples of wire shall be carefully examined for conformance to those requirements of this specification, which are not covered by tests.

4.6.2 Conductor.

4.6.2.1 Continuity of coating. The continuity of coating test for the individual silver-coated strands of the conductor shall be performed as specified in [ASTM B298](#).

4.6.2.2 Thickness of coating. The thickness of coating test for the individual silver-coated strands of the conductor shall be performed as specified in [ASTM B298](#).

MIL-DTL-8777E

4.6.2.3 Conductors, elongation. Elongation tests on the copper strand removed from the finished wire shall be performed as specified in method 3211 of [FED-STD-228](#).

4.6.3 Primary insulation.

4.6.3.1 Concentricity. The concentricity of the primary insulation shall be determined as specified in [4.6.3.1.1](#) and [4.6.3.1.2](#). All wall thickness measurements shall be determined under suitable magnification.

4.6.3.1.1 Primary insulation (wire sizes 22 through 12). The concentricity of the primary insulation of wire sizes 22 through 12 shall be determined by first locating and recording the minimum wall thickness of a cross section of the primary insulation. The maximum wall thickness of this same cross section shall be measured and recorded. A wall thickness measurement shall be interpreted to be the minimum distance between the outer rim of the outermost strand of the conductor and the outer rim of the primary insulation. Percent concentricity is defined as 100 times the ratio of the minimum wall thickness to the maximum wall thickness.

4.6.3.1.2 Primary insulation (sizes 10 through 00). The concentricity of the primary insulation shall be determined, on a cross section of the insulation removed from the finished wire, by first locating and recording the minimum wall thickness of the primary insulation. From this point, on the outer rim of the primary insulation at which the minimum wall thickness was measured, three more reference points 90 degrees apart on the outer rim of the primary insulation shall be established. At each of these three reference points, the nearest member of a rope-lay conductor shall be selected and the insulation wall thickness between that member of the rope-lay conductor and the outer rim of the primary insulation shall be measured. The average of the four readings shall be considered to be the average wall thickness. A wall thickness measurement shall be interpreted to be the minimum distance between the outer rim of the primary insulation and rim of the outermost strand of the stranded member of the rope-lay conductor. Percent concentricity is defined as 100 times the ratio of the minimum wall thickness to the average wall thickness.

4.6.3.2 Physical properties of extruded primary insulation.

4.6.3.2.1 Tensile strength and elongation. Physical properties tests of the primary insulation shall be made on samples removed from the finished wire, and as specified in method 3211 of [FED-STD-228](#).

4.6.3.2.2 Aging.

4.6.3.2.2.1 Air oven (quality conformance test). Specimens of the primary insulation removed from a finished wire shall be suspended in a gravity-convection type air oven at a temperature of $232^{\circ} \pm 5^{\circ}\text{C}$ for 6 hours. Following this procedure, the tensile strength and elongation of the specimens shall be measured within 16 to 48 hours after removal from the air oven and as specified in method 3211 of [FED-STD-228](#).

4.6.3.2.2.2 Air oven (qualification test). The test specified in 4.6.3.2.2.1 shall be performed as specified, except that the temperature shall be $200^{\circ} \pm 5^{\circ}\text{C}$ and the exposure time 200 hours.

4.6.3.2.2.3 Oxidation (qualification test). Specimens similar to those employed in the tensile strength and elongation test specified in [4.6.3.2.1](#) shall be placed in an oxygen bomb (Bierer-Davis or equivalent) and subjected to an oxygen pressure of 300 psi and a temperature of $80^{\circ} \pm 3^{\circ}\text{C}$ for 7 days. Following this test, the tensile strength and elongation of the specimens shall be measured with 16 to 48 hours after removal from the oxygen bomb, and as specified in method 3211 of [FED-STD-228](#).

MIL-DTL-8777E

4.6.3.3 Extruded primary insulation flaws. After application of the extruded silicone insulation, and prior to the application of any other material, the wire shall be passed through a chain-electrode spark-test device, without breakdown, using the voltage specified in the applicable MS sheet for extruded insulation. The electrode shall be of a suitable bead chain of fine mesh construction that will give intimate metallic contact with practically all the wire insulation surface. Electrode length and speed of wire movement shall be such that the insulation is subjected to the test voltage for not less than 0.2 second.

4.6.4 Finished wire.

4.6.4.1 Conductor resistance. The dc resistance measurement made on the conductor shall be as specified in method 6041 of [FED-STD-228](#).

4.6.4.2 Finished wire flaws. The finished wire shall be passed through a chain-electrode spark-test device, without breakdown, using the voltage specified in the applicable MS sheet for finished wire. The electrode shall be of a suitable bead chain of fine mesh construction that will give intimate metallic contact with practically all the wire insulation surface. Electrode length and speed of wire movement shall be such that the insulation is subjected to the test voltage for not less than 0.2 second.

4.6.4.3 Life cycle.

4.6.4.3.1 Air oven. One inch of the insulation shall be removed from each end of a 24 inch (609.60 mm) sample of finished wire. The central portion of the specimen shall then be bent at least halfway around a cylindrical mandrel having a diameter as specified in the applicable MS sheet. Each end of the conductor shall be loaded in such a manner that the portion of the compound between the conductor and mandrel is under compression while the conductor is under the tension specified in the applicable MS sheet. The condition shall be maintained for 120 hours in air maintained at $215^{\circ} \pm 5^{\circ}\text{C}$. Following the air oven test, the specimen shall be cooled to $25^{\circ} \pm 3^{\circ}\text{C}$ within 1 hour. Following this cooling, the wire shall be freed from tension, removed from the mandrel, and straightened. The specimen shall then be subjected successively to the test of [4.6.4.3.2](#), [4.6.4.3.3](#), and [4.6.4.3.4](#).

4.6.4.3.2 Bend. In a temperature of $23^{\circ} \pm 3^{\circ}\text{C}$, the specimen shall be secured to the mandrel and the other end to the load weight as specified in the applicable MS sheet. The mandrel shall be rotated until the length of the specimen is wrapped around the mandrel under the specified tension and with its adjoining coils in contact. The mandrel shall then be rotated in reverse direction until the length of the cable which was outside during the first wrapping is now next to the mandrel. This procedure shall be repeated until two bends in each direction have been formed in the same section of the wire.

4.6.4.3.3 Dielectric. The end of the specimen shall be fastened in metallic contact to a metal bar. The distance between the two uninsulated ends of the wire shall be not greater than the diameter of the mandrel specified in the applicable MS sheet. The specimen shall be immersed in a solution consisting of 95 parts water to 5 parts sodium chloride at a temperature of $23^{\circ} \pm 3^{\circ}\text{C}$ so that the insulation protrudes 1.5 inches (38.10 mm) from the surface of the liquid. After submersion for 5 hours, 1,500 volts rms at 60 hertz frequency shall be applied between the conductor and an electrode in contact with the liquid. This voltage shall be increased at a uniform rate from 0 to 1,500 volts within 0.5 minute and maintained at 1,500 volts for 5 minutes.

4.6.4.3.4 Pitting. The insulation of the specimen shall be removed and the conductor examined for pitting.

4.6.4.4 Cold bend. One end of a previously untested specimen of suitable length shall be secured to the mandrel as specified in the applicable MS sheet and the other end to the load weight specified in the applicable MS sheet. The wire and mandrel assembly shall be lowered to $-55^{\circ} \pm 3^{\circ}\text{C}$ at a rate not to

MIL-DTL-8777E

exceed 50° per minute. After maintaining this temperature for 4 hours, and while still at this low temperature, the cable shall be wrapped around the mandrel for 180° without opening the cold chamber. A revolving mandrel inside the cold chamber and operated by a control external to the chamber shall be used. The time required for bending the sample around 180° of the mandrel shall be 30 seconds and the bending shall be performed at a uniform rate of speed. The specimen shall then be examined for cracks (see 3.4.4.4). The insulation shall be removed for a distance of 1 inch (25.40 mm) from each end of the specimen and the specimen subjected to the test specified in 4.6.4.3.3 with the bent portion submerged.

4.6.4.5 Oil absorption. A specimen of untested wire not less than 24 inches (609.60 mm) long shall be immersed to within 1.5 inches (38.10 mm) from each end in a liquid containing equal parts of kerosene and aircraft-engine lubricating oil, and a temperature of 50° ±5°C for 20 hours. The specimen shall then be examined for increase in diameter, after which it shall be successively subjected to the tests specified in 4.6.4.3.2 and 4.6.4.3.3.

4.6.4.6 Immersion. Separate specimens of wire, not less than 24 inches (609.60 mm) long, shall be immersed to within 6 inches (152.40 mm) of each end, for a period of 20 hours at normal room temperature, in each of the following fluids (using a separate specimen for each fluid):

- a. Lubricating oil conforming to [MIL-PRF-7808](#).
- b. Hydraulic fluid conforming to [MIL-PRF-5606](#).
- c. Hydraulic fluid conforming to [SAE AS1241](#).
- d. Jet fuel (grade JP-4) conforming to [MIL-DTL-5624](#).
- e. Isopropyl alcohol conforming to [TT-I-735](#).

Upon removal from the fluid, the specimen shall remain for 1 hour in free air at normal room temperature. The insulation shall be removed for a distance of 1 inch (25.40 mm) from each end of the specimen and the specimen subjected to the test specified in 4.6.4.3.3. During immersion tests, the bend of the wire shall be not less than 14 times the maximum specified diameter of that particular size wire.

4.6.4.7 High temperature endurance. The wire shall be subjected to the current loading specified for single cables in free air as specified in the table titled "Current-carrying capacity of wires and cables" as specified in [MIL-W-5088](#), except that the ambient temperature shall be 150° ±5°C for 200 hours. Separate samples of the wire shall then be tested as specified in and shall meet the requirements of the tests specified in 4.6.4.3.3, 4.6.4.4, and 4.6.4.5.

4.6.4.8 Flammability.

4.6.4.8.1 Apparatus. A Bunsen burner having a 0.25 inch (6.35mm) inlet, a nominal bore of .0375 inch (9.53 mm), and a stem or burner length of approximately 4 inches (101.60 mm) above the air inlets shall be used for the tests. The Bunsen burner shall be of the type having a needle valve for gas adjustment built into the bottom of the burner. A wing-top flame spreader having a 0.0625 inch (1.59 mm) by 2 inch (50.80 mm) opening shall be fitted on the tip of the burner. The air inlet valve and the gas needle valve shall be adjusted so that a 2 inch (50.80 mm) high all blue flame is obtained having a temperature of 870° ±30°C at the top. It is optional to use a 2 inch (50.80 mm) high flame having an inner cone 0.33 inch (8.38mm) its height, provided the tip of the inner cone shall have the specified temperature. The shape of the 2 inch (50.80 mm) flame spreader and the flame shall be as illustrated on [figure 1](#).

MIL-DTL-8777E

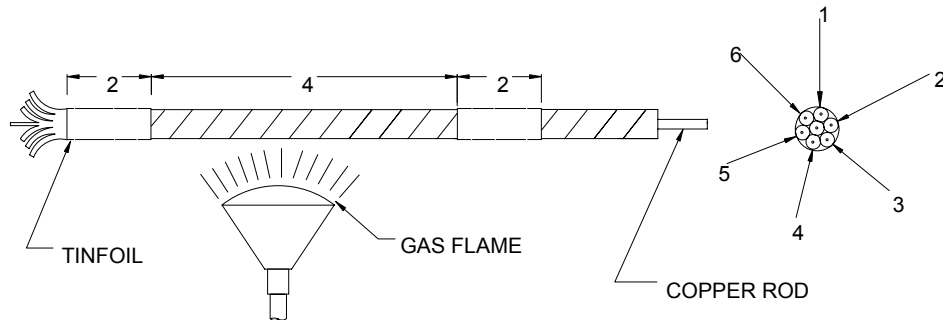

FIGURE 1. Flammability test, procedure I.

4.6.4.8.2 Flammability test – procedure I. Six specimens of wire, each of the same size and approximately 15 inches (381.00 mm) in length, shall be wound around a solid copper core of a diameter approximately equal to that of an individual specimen. Tinfoil strips, 2 inches (50.80 mm) wide, shall be wrapped around each end of the assembly in such a manner that the center 4 inch (101.60 mm) portion of the assembly is exposed (see figure 1). The assembly shall be held or suspended in a horizontal position within an enclosure which allows a flow of sufficient air for combustion but is free from drafts. The top of the 2 inch (50.80 mm) all blue flame or the top of the inner cone of the optional flame shall be applied directly under the center of the exposed 4 inch (101.60 mm) center section of the assembly for a period of 5 minutes. The stem of the burner shall be in a vertical position and the flame spreader opening shall be parallel to the assembly. The position of the apparatus in relation to the assembly shall be as specified on figure 1. After removal of the flame, the assembly shall be cooled to room temperature and shall then withstand, without breakdown, the following dielectric tests:

- a. A potential of 800 volts rms, 60 Hz, applied for 5 minutes between the conductors of the wire specimens, electrically connected together, and the metal rod (the tinfoil strips common with the rod).
- b. A potential of 800 volts rms, 60 hertz, applied for 5 minutes between conductors of alternate wire specimens. Conductors 1, 3, and 5 shall form one electrode and conductors 2, 4, and 6 shall form the other (see figure 1).
- c. The specimen assembly shall be placed on a metal plate that is in intimate contact with and supports the 4-inch center burned section. A potential of 800 volts rms, 60 hertz, shall be applied for 5 minutes between the conductors of the wire specimens, electrically connected together, and the metal plate.

MIL-DTL-8777E

4.6.4.8.3 Flammability test – procedure II. A specimen of completed wire of sufficient length shall be suspended taut in a horizontal position within an enclosure which allows a flow of sufficient air for combustion but is free from drafts. The tension applied to the specimen shall be sufficient to prevent sagging of the specimen during application of the flame. A piece of facial tissue paper shall be suspended taut and horizontal 9.5 inches (241.30 mm) directly below the cable and at least 0.5 inch (12.70 mm) away from the table top. Melted or dripping material from the wire specimen shall fall on the tissue paper. The top of the 2 inch (50.80 mm) flame of the top of the inner cone of the optional flame is applied directly under the center section of the specimen for a period of 15 seconds for wire sizes 22 through 10 and 30 seconds for wire sizes 8 and larger. The stem of the burner shall be in a vertical position and the flame spreader opening shall be parallel to the wire specimen. The position of the apparatus in relation to the specimen shall be as specified on figure 1. Before removal of the gas flame from the specimen at the end of the ignition period, a marking wire or indicator shall be placed approximately 0.5 inch (12.70 mm) away from the wire, locating on the burning specimen the outer edge of burning at each side of the flame. The rate of flame travel and self-extinguishing time shall be measured from both indicating points. During the entire flame test, the Bunsen burner supporting rack shall remain stationary.

4.6.4.9 Abrasion.

4.6.4.9.1 Abrasion – procedure I. This test shall be performed on an abrasion testing machine conforming to appendix A. One inch of the insulation shall be removed from one end of a 36 inch (914.40 mm) sample of finished wire. The specimen shall be placed in the test machine and subjected to the tension load specified in the applicable MS sheet. Using the weight support bracket and weight specified in the applicable MS sheet, the sample shall then be subjected to the abrasion test. After each reading, the specimen shall be moved forward 2 inches (50.80 mm) and rotated clockwise 90°. Eight readings shall be obtained for each sample. An average shall be obtained by calculating the arithmetic mean of all those readings for that wire which is individually less than the arithmetic mean of all the eight readings per wire. This average shall define the abrasion resistance of the wire under test.

4.6.4.9.2 Abrasion – procedure II. Previously untested specimens of wire, each 36 inches (914.40 mm) long, shall be immersed in fluids as specified in the procedure specified in 4.6.4.6. After removal from the fluids, the specimens shall be air-dried at 25° ±4°C for 24 hours and shall then be subjected to procedure I as specified in 4.6.4.9.1.

4.6.4.10 Humidity resistance. A 52-foot sample of wire shall be subjected to the test specified in 4.6.4.10.2 for not less than 14 days, following which the wire shall be subjected to the test specified in 4.6.4.10.3.

4.6.4.10.1 Apparatus. The apparatus shall consist of a test chamber capable of maintaining an internal temperature of 71° ±2°C and an internal relative humidity of 95 ±5 percent. The test chamber shall be capable of being sealed in order to retain the total moisture content in the test space. The heat loss from the chamber shall be sufficient to reduce the internal temperature from the preceding operating temperature to not greater than 38°C within 16 hours from the time of removal of the source of heat. Distilled or demineralized water shall be used to obtain the required humidity.

MIL-DTL-8777E

4.6.4.10.2 Procedure. The specimen shall be placed in the test chamber and the temperature and relative humidity raised to the specified values and maintained for 6 hours. At the end of the 6-hour period, the heat shall be shut off. During the following 16-hour period, the temperature shall be reduced to not greater than 38°C. At the end of the 16-hour period, heat shall again be supplied for an additional 2-hour period and the temperature stabilized to 71° ±2°C. This cycle shall be repeated a sufficient number of times to extend the total time of the test to 360 hours (15 cycles).

4.6.4.10.3 Insulation resistance measurements. Insulation resistance measurements shall be made with the external surface of the wire grounded and the conductor remaining at elevated potential. The insulation resistance shall be determined after 1-minute electrification with a direct-current potential of 250 to 500 volts. Where the wire is shielded, connections shall be made at the shielding and the conductor. Unshielded wires shall be submerged in a 5% solution of NaCl and H₂O. The insulation resistance measurements test shall be conducted at 22° ±3°C.

4.6.4.11 Insulation resistance. A 52-foot specimen with its center 50-foot section shielded as specified in MIL-PRF-7808, but with not less than 95 percent coverage, shall be coiled and suspended in a gravity-convection type air oven adjusted to 200° ±5°C and held for 100 hours. At the end of this period and while at this temperature, the insulation resistance shall be measured between the conductor and the shield.

4.6.4.12 Surface resistance. Specimens shall consist of 6 inch lengths of finished wire and provided with two 0.25 inch (6.35 mm) ring type metal foil electrodes, or for small wires, several turns of fine tin coated copper wire, spaced 1.0 inch (25.40 mm) apart between the nearest edges near the center of the specimen length, wrapped snugly around axis of the specimen and bound with the takeoff leads for electrical testing of surface between the electrodes. After conditioning these specimens for 96 hours at a relative humidity of 95 ±5 percent and a temperature of 25° ±5°C, the resistance between the electrodes shall be measured using a dc potential of 200 to 500 volts while the specimens are still within the conditioning chamber and after a 1 minute electrification. The surface resistance shall be computed by multiplying the measured resistance value by the measured overall diameter of the specimen in inches. Following the initial resistance measurement, the potential specified in the applicable MS sheet shall be applied between the electrodes for 1 minute. After a discharge interval of 15 to 20 minutes following the potential test, the surface resistance shall be remeasured and computed.

4.6.4.13 Smoke. This test shall be performed in still air at normal room temperature. A specimen of the wire approximately 15 feet long shall be so suspended that a section no less than 10 feet long is horizontal and unsupported. One end of the wire shall be suitable weighted in order that no sagging will occur throughout the test. An electric current shall be applied to the wire, and the voltage drop measured over the 10-foot portion. From the current and voltage values, the resistance of the cable shall be calculated. The temperature of the cable conductor shall be determined from the change in resistance. The current shall be so adjusted that the conductor temperature stabilizes at 210° ±5°C. This conductor temperature shall be maintained for 15 minutes. A flat black background shall be used.

4.6.4.14 Wire weight. The weight of each lot of finished wire shall be determined by procedure I of 4.6.4.14.1. Lots failing to meet the wire weight requirements of 3.4.3.2 when tested as specified in procedure I shall then be submitted to procedure II of 4.6.4.14.2, and all reels or spools failing to meet the weight requirements of 3.4.3.2 shall be finally rejected. Group I sampling shall not apply to procedure II.

4.6.4.14.1 Wire weight – procedure I. The length of a specimen at least 10 feet long shall be accurately measured with the resultant measurement transposed to pounds per 1,000 feet.

MIL-DTL-8777E

4.6.4.14.2 Wire weight – procedure II. The net weight of the finished wire on each reel or spool shall be obtained by subtracting the tare weight of the reel or spool from the gross weight of the reel or spool containing the finished wire. The net weight of wire on each reel or spool shall be divided by the accurately determined length of finished wire on that reel or spool and the resultant transposed to pounds per 1,000 feet. When wood or other moisture absorbent materials are used for reel or spool construction, weight determinations shall be made under substantially the same conditions of relative humidity.

4.6.4.15 Thermal shock resistance.

4.6.4.15.1 Preparation of specimen. A specimen of wire, 5 feet long, shall be prepared by carefully removing 1 inch (25.40 mm) of insulation from each end of the wire. (For purposes of this test, insulation is defined as all layers of non-conducting material covering the electrical conductor, e.g., primary insulation, all tapes and braids, and the jacket.) A razor blade or equivalent, held perpendicular to the axis of the wire, shall be used to cut the insulation for the removal operation. The length of exposed conductor at each end of the specimen shall be measured to the nearest 0.01 inch (.25 mm). The specimen shall be formed into a loose coil not less than 1 foot in diameter and shall be laid on a wire screen for handling throughout the test.

4.6.4.15.2 Test procedure. The specimen shall be placed for 30 minutes in a preheated air-circulating oven at the temperature specified in the applicable MS sheet, or at the rated temperature of the wire if no oven temperature for the test is specified in the applicable MS sheet. It shall then be removed from the oven and, within 2 minutes, placed in a chamber which has been precooled to $-55^{\circ} \pm 2^{\circ}\text{C}$. The specimen shall be exposed to this temperature for 30 minutes, after which it shall be removed and allowed a minimum of 30 minutes to return to room temperature, 20° to 25°C . At the conclusion of this cycle, the distance from the end of each layer of insulation to the end of the conductor shall be measured to the nearest 0.01 inch (.25 mm). This thermal shock cycle and the measurements shall be repeated for an additional three cycles (a total of four cycles). Any measurement varying from the original measurement by more than the amount specified in the applicable MS sheet, or by more than 0.06 inch (1.52 mm), if no amount is specified, shall constitute failure. Any flaring of any layer shall also constitute failure.

4.6.4.16 Durability of color markings. The durability of product identification or color strippings applied to the wire for coding shall be evaluated at 20° to 25°C as follows:

4.6.4.16.1 Durability testing apparatus. The markings durability tester shall be designed to hold a short specimen of finished wire firmly clamped in a horizontal position with the upper longitudinal surface of the specimen fully exposed. The instrument shall be capable of rubbing a small cylindrical steel mandrel (usually a needle), 0.025 inch (.64 mm) in diameter, repeatedly over the upper surface of the wire, in such position that the longitudinal axes of the mandrel and the specimen are at right angles to each other with cylindrical surfaces in contact. A weight affixed to a jig above the rubbing mandrel shall control the thrust exerted normal to the surface of the insulation. A motor driven, reciprocating cam mechanism and counter shall be used to deliver an accurate number of abrading strokes in a direction parallel to the axis of the specimen. The length of the stroke shall be 0.375 inch (9.53 mm) and the frequency of the stroke shall be 120 strokes (60 stroking cycles) per minute.

4.6.4.16.2 Durability testing procedure. In performing the test, a specimen of wire shall be mounted in the specimen clamp and the applicable total weight shall be applied through the rubbing mandrel to the marked surface. The counter shall be set at zero and the drive motor started. The specimen shall be observed throughout the progress of the test and, as soon as a continuous line of the printed marking is removed under the mandrel, the number of cycles shall be recorded. Three specimens from each sample unit shall be tested and the results from the three specimens shall be averaged.

MIL-DTL-8777E

5. PACKAGING

5.1 Packaging. For acquisition purposes, the packaging requirements shall be as specified in the contract or order (see 6.2). When actual packaging of materiel is to be performed by DoD personnel, or in-house contractor personnel, these personnel need to contact the responsible packaging activity to ascertain packaging requirements. Packaging requirements are maintained by the Inventory Control Point packaging activities within the Military Service or Defense Agency, or within the military service's system command. Packaging data retrieval is available from the managing Military Service or Defense Agency's automated packaging files, CD-ROM products, or by contacting the responsible packaging activity.

6. NOTES

(This section contains information of a general or explanatory nature that may be helpful, but is not mandatory.)

6.1 Intended use. The electric wire covered by this specification is intended for installation on aircraft and missile electrical systems where the potential does not exceed 600 volts rms. For applications at altitudes above 60,000 feet, the voltage ratings for the respective wire should be reviewed for each specific application.

6.2 Acquisition requirements. Acquisition documents should specify the following:

- a. Title, number, and date of this specification (see 1.2).
- b. MS part or identification number (PIN) of the wire desired.
- c. If required, the specific issue of individual documents referenced (see 2.2.1 and 2.3).
- d. Wire length (see 6.2.1).
- e. Packaging requirements (see 5.1, 6.2.2, and 6.2.3).

6.2.1 Wire length. No less than 85 percent of the total quantity of each size of wire ordered will be in lengths equal to or greater than the nominal length specified in table VI. No wire will be accepted in lengths shorter than the specified minimum acceptable length. The maximum quantity of wire in a single length will be limited only by manufacturing and handling facilities.

TABLE VI. Wire lengths.

Wire size AWG	Nominal length on reel or spool (feet)	Minimum acceptable length (feet)
22 to 6, inclusive	500	100
4 to 2, inclusive	250	50
1 to 00, inclusive	100	25

6.2.2 Reels and spools. Wire will be delivered wound on non-returnable reels or spools, each having an appropriate diameter for the respective size. In no case will the barrel of the reel or spool be less than 5.5 inches (139.70 mm) in diameter. The footage of individual continuous wire lengths will be marked on each reel or spool in the sequence of unwinding.

MIL-DTL-8777E

6.2.3 Special marking. In addition to packaging markings that may be specified by the organizations cited in 5.1 and the acquisition documents (see 6.2e), special marking for packaging must include the following:

- a. Number of this specification.
- b. MS PIN.
- c. Wire size.
- d. Date of manufacture.
- e. Name of manufacturer.

6.3 Qualification. With respect to products requiring qualification, awards will be made only for products, which are, at the time of award of contract, qualified for inclusion in Qualified Products List QPL No. 3702 whether or not such products have actually been so listed by that date. The attention of the contractors is called to these requirements, and manufacturers are urged to arrange to have the products that they propose to offer to the Federal Government tested for qualification in order that they may be eligible to be awarded contracts or purchase orders for the products covered by this specification. Information pertaining to qualification of products may be obtained from the Defense Supply Center Columbus, ATTN: DSCC-VQP 3990 East Broad Street, Columbus, Ohio 43218-3990.

6.4 Subject term (key word) listing.

Abrasion
Aging
Concentric lay
Elongation
Flammability
Immersion
Oil absorption
Rope lay
Smoke
Tensile strength

6.5 Changes from previous issue. Marginal notations are not used in this revision to identify changes with respect to the previous issue, due to the extent of the changes.

6.6 Environmentally preferable material. Environmentally preferable materials should be used to the maximum extent possible to meet the requirements of this specification. Table VII lists the Environmental Protection Agency (EPA) top seventeen hazardous materials targeted for major usage reduction. Use of these materials should be minimized or eliminated unless needed to requirements specified herein (see section 3).

TABLE VII. EPA top seventeen hazardous materials.

Benzene	Dichloromethane	Tetrachloroethylene
Cadmium and Compounds	Lead and Compounds	Toulene
Carbon Tetrachloride	Mercury and Compounds	1,1,1 Trichoroethane
Chloroform	Methyl Ethyl Ketone	Trichloroethylene
Chromium and Compounds	Methyl Isobutyl Ketone	Xylenes
Cyanide and Compounds	Nickel and Compounds	

MIL-DTL-8777E
APPENDIX A

ABRASION TESTER FOR ELECTRICAL CABLE

A.1 SCOPE

A.1.1 Scope. This Appendix is a mandatory part of this specification. The information contained herein is intended for compliance and establishes the requirements for electrical abrasion testers. The abrasion tester is intended to provide a means of comparing the abrasion resistance of various types of electrical cable insulation.

A.2 APPLICABLE DOCUMENTS

(This section is not applicable to this appendix.)

A.3 REQUIREMENTS

A.3.1 Design. The abrasion tester shall be designed to provide a means of comparing the abrasion resistance of various types of cable insulation.

A.3.2 Construction. The tester shall consist of an assembly including an electric motor, pulley system, measuring device, detecting circuit, and a weight system. Component parts of the abrasion tester shall be located as shown on [figure A.1](#).

A.3.2.1 Motor. The drive motor shall have sufficient torque to maintain constant speed within 5 percent over the entire loading range of the machine.

A.3.2.2 Pulley system. The pulley system shall include the following parts: drive-wheel, tension wheel, two reels, tape-aligning guide, and tape-positioning guide.

A.3.2.2.1 Drive wheel. The drive wheel shall be rubber faced and suitable for driving the tape at the specified rate of speed.

A.3.2.2.2 Tension wheel. The tension wheel shall be rubber faced and shall transmit sufficient pressure to the drive wheel through the tape to eliminate slippage.

A.3.2.2.3 Reels. Reels shall be provided to hold the abrasive tape. The capacity of each reel shall be sufficient to hold 50 yards of tape. Reels shall be secured to their spindles by a locking device in such a manner that they can be removed readily yet shall not become unlocked during operation. The machine shall be constructed to prevent excessive unwinding of the loaded reel and to wind the tape on the empty reel.

A.3.2.2.4 Tape aligning guide. The tape-aligning guide shall be constructed as specified in detail A on [figure A.2](#).

A.3.2.2.5 Tape positioning guide. The tape-positioning guide shall be constructed as specified in detail B on [figure A.2](#). This guide shall be mounted as shown on [figure A.1](#).

A.3.2.3 Tape measuring device. The tape-measuring device shall provide a means to determine the length of abrasive tape that has contacted the cable under test.

A.3.2.4 Detecting circuit. The detecting circuit shall stop the machine when the insulation of the cable under test fails. A schematic diagram of a typical circuit is shown on [figure A.3](#). The direct-current resistance of the detection circuit may vary from 3000 to 6000 ohms. A relay shall be provided that can be actuated with the resistance in series.

A.3.2.5 Weight system. A weight system shall be provided to apply various loads to the cable at the point where it is being abraded.

A.3.2.5.1 Weight support brackets. Weight support rod and weights shall conform to the requirements of details C, E, and F on [figure A.2](#). The combined weight of any weight support bracket

MIL-DTL-8777E
APPENDIX A

and weight support rod shall be 0.12 pound.

A.3.2.5.2 Pivoted support arm. The pivoted support arm shall conform to dimensions shown in detail D on [figure A.2](#). The pivot shall be as friction free as possible and shall be located so that the arm is horizontal when the bracket is in test position (see [figure A.1](#)). This support arm shall have a range of motion at right angles to the travel of the tape sufficient to bring the weight support bracket over any position of the tape.

A.3.2.6 Abrasive tape. Each roll of tape shall consist of a continuous strip 1 inch wide and 50 yards long. The abradant on the tape shall be aluminum oxide, grit 400, and the detection cross stripes of conductive silver paint on the tape shall be 0.25 inch (6.35 mm) wide, spaced 3 inches (76.20 mm) apart, center to center.

A.3.2.6.1 Preparation of tape for detection circuit. Detection strips shall be applied to the abrasive tape by coating sections with an aquadag or equivalent solution applied in strips 0.375 inch (9.53 mm) wide across the abrasive surface of the tape at right angles to its edge. The strips shall be placed 6 inches (152.40 mm) \pm 0.25 inch (6.35 mm) center to center, and such that any 11 consecutive strips shall measure 60 inches (1524.00mm) \pm 1 inch (25.40 mm), center to center. The 0.375 inch (9.53 mm) strips painted on the abrasive tape shall serve as an electrical conductor in the detection circuit and provide an indication as to when the insulation on the cable is worn through. The solution shall consist of 1 ounce of aquadag or equivalent conducting colloid to 1.5 ounces of water. The resulting solution should have a consistency of heavy motor oil. The applied coating shall have an average thickness of 0.0007 inch (.02 mm) and an average direct-current resistance of 15,000 ohms measured across a 0.75 inch (19.05 mm) length when the solution is air-dried. Care should be taken not to apply the aquadag or equivalent solution too thickly at one application, nor to dry it at temperatures above 27°C (80.6°F) since the coating has a tendency to crack excessively under these conditions, producing a high resistance path. If the dried coating is not cracked and its direct current resistance is too high, another coating may be applied.

A.3.2.7 Cable clamps. Cable clamps shall be provided to hold the test cable firmly in a horizontal position as shown on [figure A.1](#). By means of these clamps it shall be possible to position the cable over any portion of the tape at right angles to the motion of the tape.

A.3.3 Performance.

A.3.3.1 Speed. The tester shall apply the abradant to the surface being tested at the rate of 60 inches (1524.00 mm) \pm 3 inches (76.20 mm) per minute.

A.3.3.2 Slippage. The tape shall travel at a uniform rate of speed. There shall be no slippage.

A.3.3.3 Accuracy of tape-measuring device. The measuring device shall record within an accuracy of 1 percent the length of tape that has come in contact with the test cable up to the point of indication of insulation failure.

A.3.4 Workmanship. The abrasion tester shall be fabricated and processed as specified in the best commercial practice for laboratory instruments.

A.4 VERIFICATION

A.4.1 Inspection tests. The abrasion tester shall be subjected to the tests specified in the following paragraphs.

A.4.1.1 Large cable test. A test length of size 0 AWG cable shall be secured in the cable clamps. With the tape measuring device set at zero, the support bracket "C" and 4.25 pound weight positioned on the cable, the machine shall be started. When the abradant breaks through the insulation, energizing the detector circuit, the machine shall stop. An auxiliary detector circuit shall be used to determine when conductor contact occurs on the Aquadag strip and to determine satisfactory performance of the detector circuit.

MIL-DTL-8777E
APPENDIX A

A.4.1.1.1 The travel distance of the abrasive tape when measured from start and stop lines on the abradant shall equal the peripheral travel of the tape drive wheel and the reading of the tape-measuring device ± 1 percent. There shall not be more than 1 percent variation in these values when determined from one continuous 300 inch cycle of operation and 5 intermittent 60 inch cycles when using a nonabradant material if necessary. The peripheral speed of the tape driving wheel shall be 60 ± 3 inches per minute. Machine performance shall not vary when tests are performed on intermediate and small size cable.

A.4.1.2 Intermediate cable test. Repeat the above test using size 8 AWG test cable, 3-pound weight, and weight support bracket "B."

A.4.1.3 Small cable test. Same as large cable test except that size 16 AWG test cable, 1-pound weight, and weight support bracket "A" shall be used instead of those specified above.

A.4.1.4 Each tester shall be carefully examined for conformance with requirements of this appendix not covered by tests.

A.4.2 Rejection and retest. Failure to meet any of the requirements of this specification shall be cause for rejection. Abrasion testers which have been rejected may be reworked or replaced to correct the defects, and resubmitted for acceptance. Before resubmitting, full particulars concerning previous rejection and the action taken to correct the defects found in the original shall be furnished the inspector.

A.5 NOTES

A.5.1 Intended use. The abrasion tester is intended to provide a means of comparing the abrasion resistance of various types of electrical cable insulation.

MIL-DTL-8777E
APPENDIX A

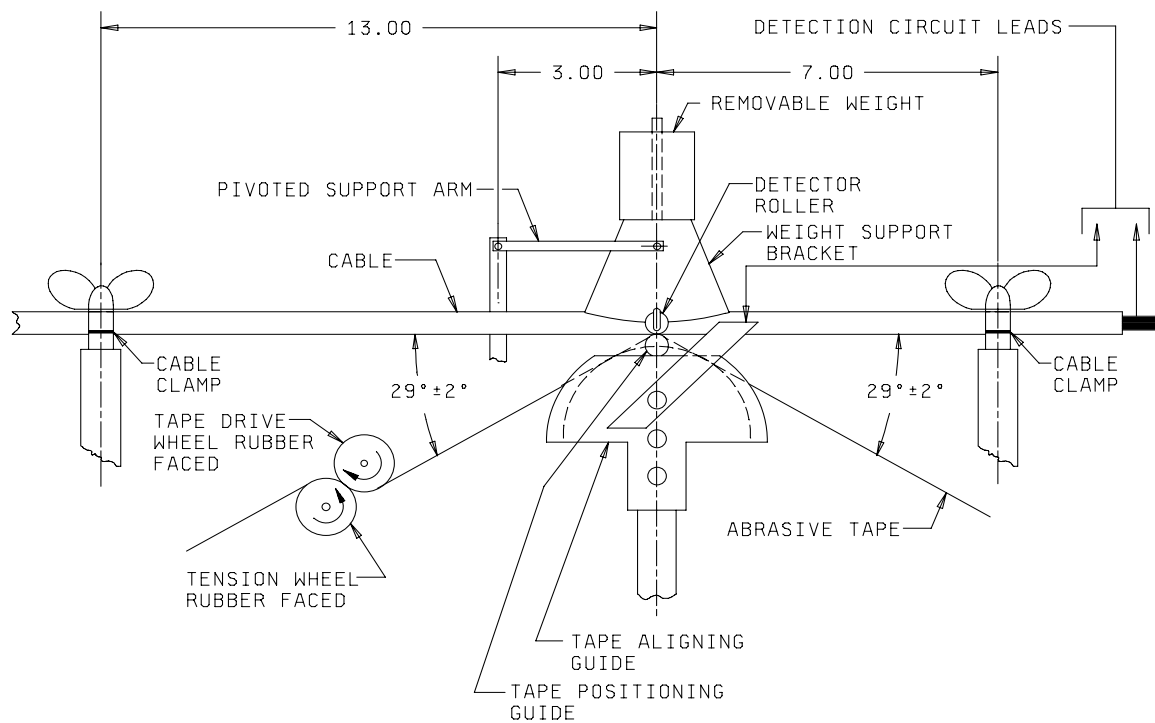
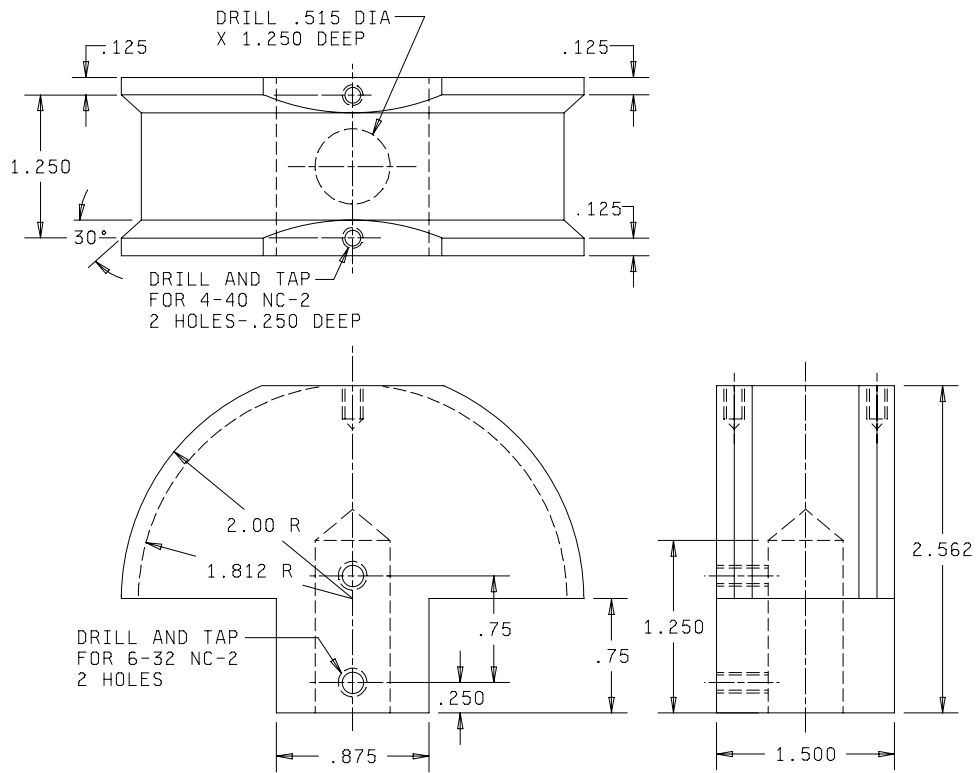
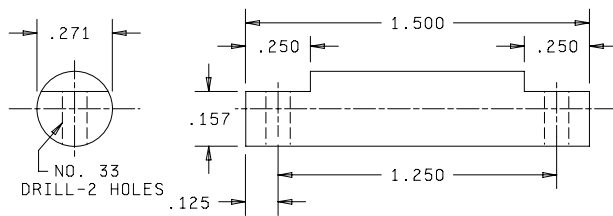

FIGURE A.1. Assembly sketch of abrasion tester.

MIL-DTL-8777E
APPENDIX A



DETAIL A
Tape Aligning Guide, one required
Material - Dural



DETAIL B
Tape Position Guide, one required
Material - Tungsten Steel

FIGURE A.2. Detail drawing of parts for abrasion tester.

MIL-DTL-8777E
APPENDIX A

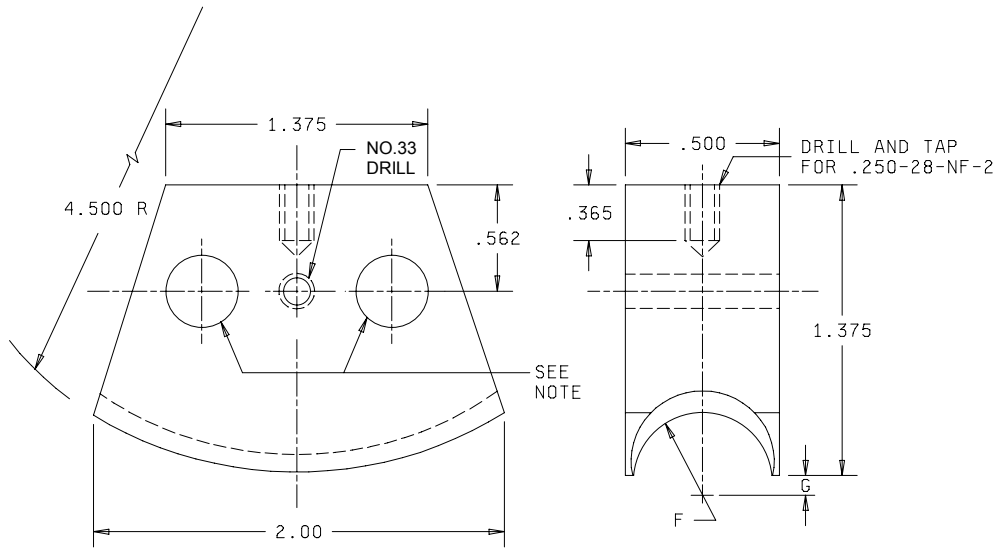

DETAIL C
Weight Support Bracket, one each required
Material - Dural

BRACKET	F	G
A	.0312	.0156
B	.0625	.0312
C	.1875	.0625

NOTE: Weight of bracket and weight support rod to be 0.12 lbs. Drill holes to suit to obtain required weight.

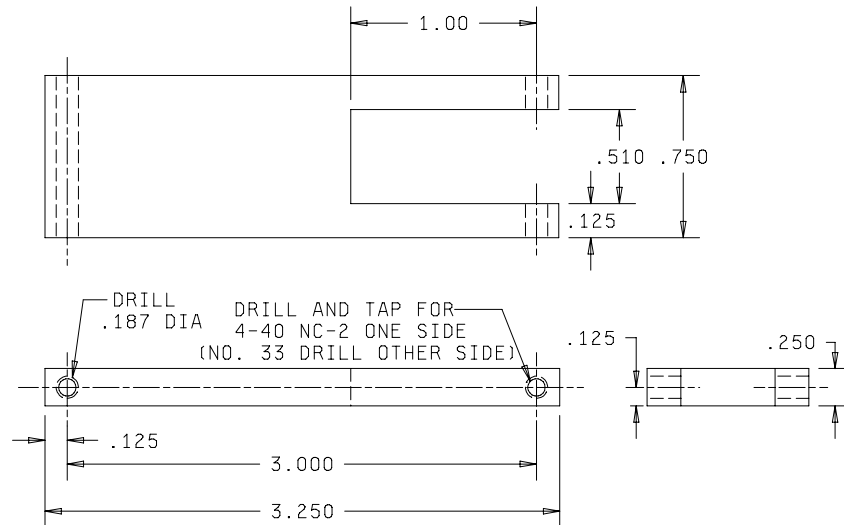

DETAIL D
Pivoted Support Rod, one required
Material - Dural

FIGURE A.2. Detail drawing of parts for abrasion tester - Continued.

MIL-DTL-8777E
APPENDIX A

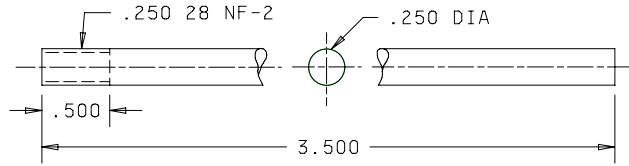

DETAIL E
Weight Support Rod, one required
Material - Dural

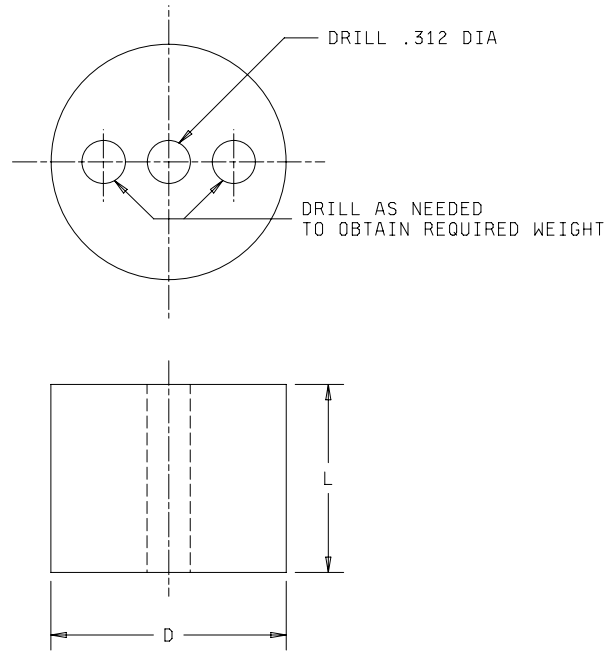

DETAIL F
Removable Weight, one each required
Material - Brass

WEIGHT	D	L
1.0 LBS	1.750	1.50
3.0 LBS	2.250	2.562
4.25 LBS	2.500	2.812

FIGURE A.2. Detail drawing of parts for abrasion tester - Continued.

MIL-DTL-8777E
APPENDIX A

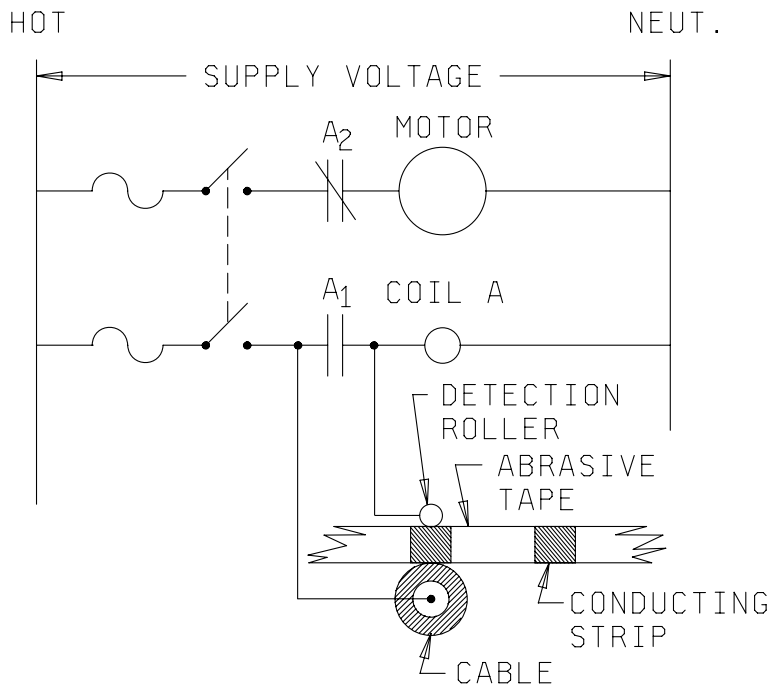

FIGURE A.3. Schematic wiring diagram of abrasion tester.

CONCLUDING MATERIAL

Custodians:

Army - AV
Navy - AS
Air Force - 11
DLA - CC

Preparing activity:
DLA - CC

(Project 6145-2007-007)

Review activities:

Army - CR4, MI
Air Force - 19

NOTE: The activities listed above were interested in this document as of the date of this document. Since organizations and responsibilities can change, you should verify the currency of this information above using the ASSIST Online database at <http://assist.daps.dla.mil>.