

INCH-POUND

MIL-DTL-868/3A(SH)

14 January 2014

SUPERSEDING

MIL-V-868/3(SH)

21 July 1989

DETAIL SPECIFICATION SHEET

VAVLES, HYDRAULIC DIRECTIONAL CONTROL, FOUR-WAY, 10-50 GPM

Reinstated after 14 January 2014 and may be used for new and existing designs and acquisitions.

This specification is approved for use by the Naval Sea Systems Command, Department of the Navy, and is available for use by all Departments and Agencies of the Department of Defense.

The requirements for acquiring the product described herein shall consist of this specification sheet and MIL-DTL-868.

1. GENERAL

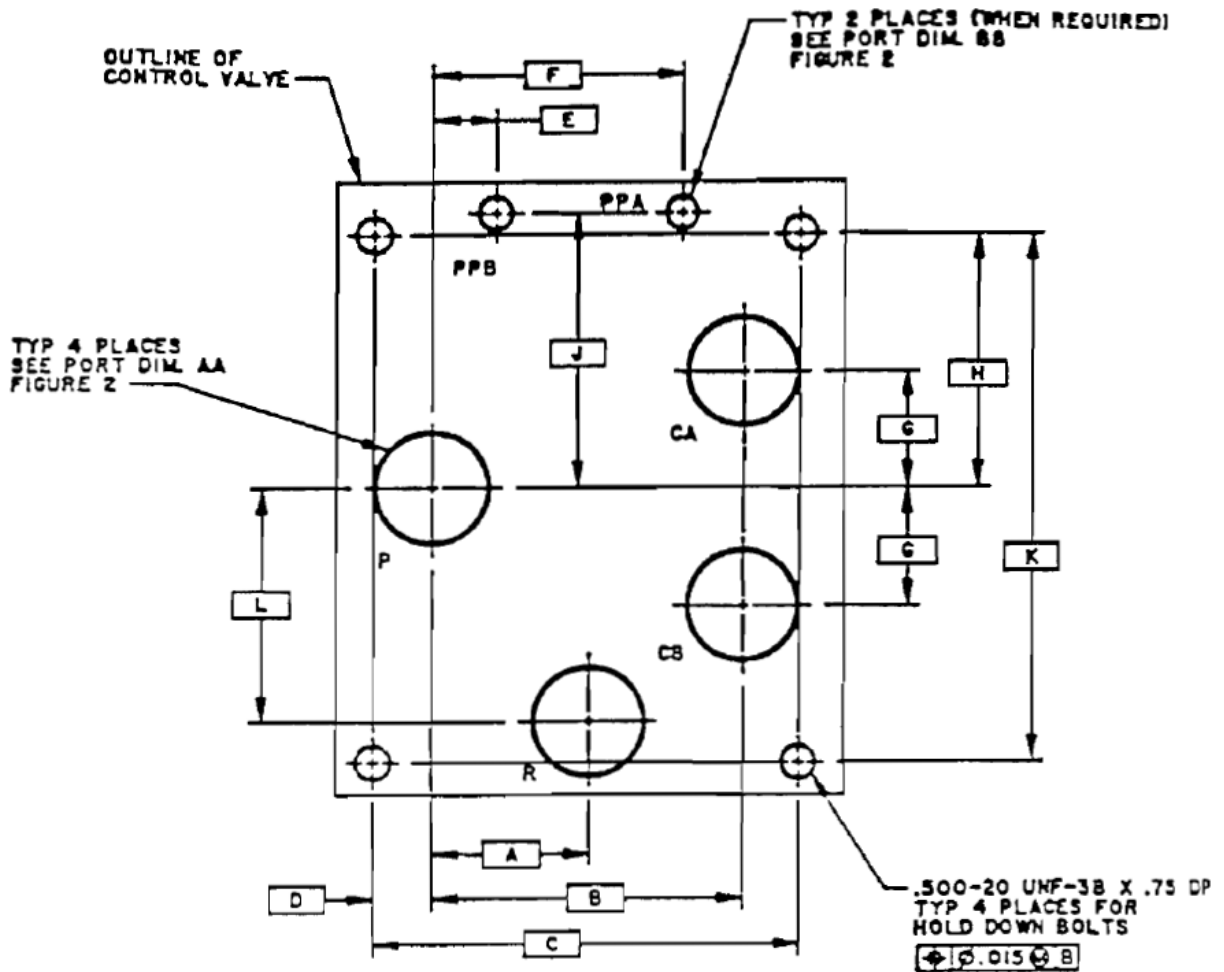
1.1 Classification. Directional control valves covered by this specification sheet shall be designated using Part or Identifying Numbers (PIN) as follows (see [table V](#) for examples of PINs) :

M	868	/3	-	WW	T	YYY	ZZ	X
Prefix to indicate a Military specification	Specification number	Applicable specification sheet number (see 1.1.1)	Left side operator (see 1.1.2)	Spool type (see 1.1.3)	Spool flow paths (see 1.1.4)	Right side operator (see 1.1.5)	Fatigue (see 1.1.6)	

1.1.1 Applicable specification sheet number. The applicable specification sheet number designates the valve's performance characteristics (flow range, pressure losses, leakage, etc.) and mounting interface configuration. [Figures 1, 2, and 3](#) define the mounting interface configuration and maximum dimensions for valves with various types of operators. Control valves covered by this specification sheet shall be of the integral slide and sleeve type.

1.1.2 Left side valve operator. The left side valve operator shall be designated by a two-character code. The left hand operator shall be designated as the actuator shown to the left of the spool symbol. On the actual valve, this corresponds to the actuator closest to the return port. For valves operated by a handle or lever, the two-character code shall be in accordance with [table I](#). The first character designates the type of operator in addition to the handle. The second character is a number (0 to 7) and indicates the positions, if any, in which the valve spool may be latched or detented. For valves without an operating handle, the left side operator shall be designated by a two-character code in accordance with [table II](#). The first letter designates the primary operator and the second letter identifies secondary operator(s), if any. See 1.1.7 for special operator configurations not covered by [tables I and II](#).

MIL-DTL-868/3A(SH)



- P = PRESSURE PORT
- R = RETURN PORT
- CA = CYLINDER PORT
- CB = CYLINDER PORT
- PPA = PILOT PRESSURE PORT A
- PPB = PILOT PRESSURE PORT B

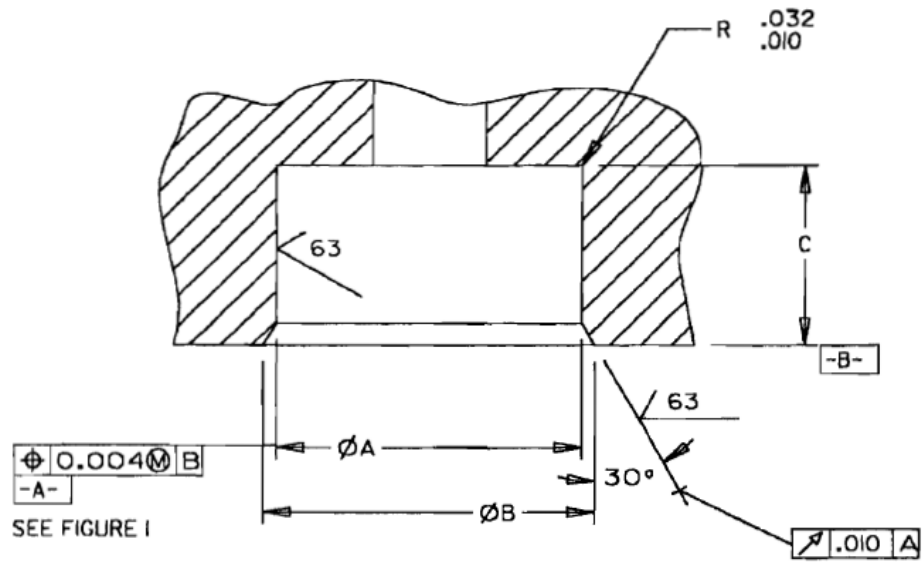
VIEW SHOWN IS
TOP OF SUBPLATE

SEE FIGURE 2
FOR LOCATION OF -B-

Dimensions in inches					
A	B	C	D	E	F
1.875	3.750	5.125	0.688	0.750	3.000
G	H	J	K	L	--
1.438	3.125	3.375	6.500	2.875	--

FIGURE 1. Valve mounting configuration.

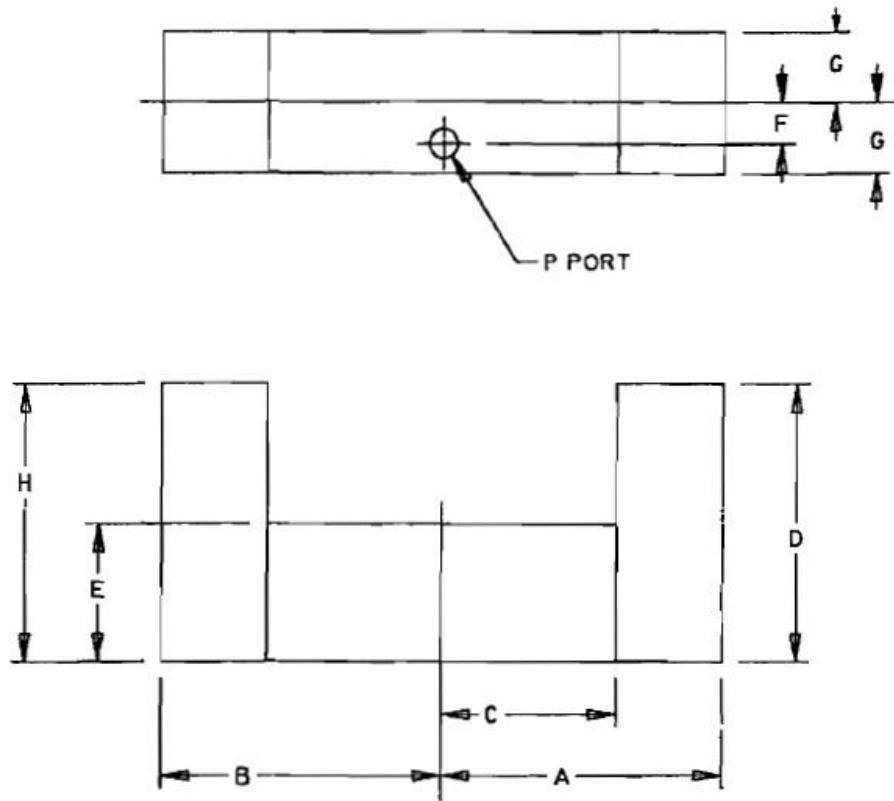
MIL-DTL-868/3A(SH)



Counterbore dimensions in inches			
Port	$\varnothing A$	$\varnothing B$	C
AA	1.303/1.305	1.352/1.382	0.503/0.509
BB	0.360/0.361	0.390/0.420	0.338/0.344

FIGURE 2. Counterbore dimensions.

MIL-DTL-868/3A(SH)



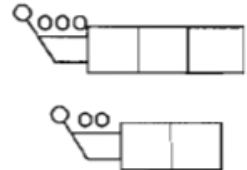
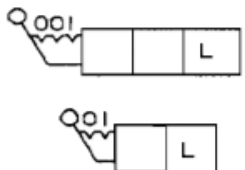
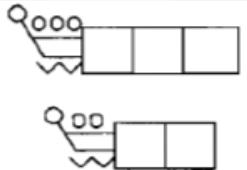
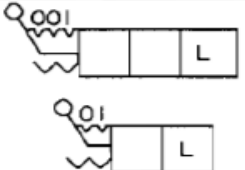
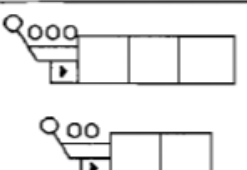
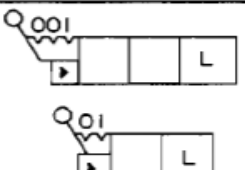
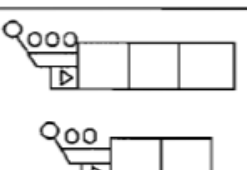
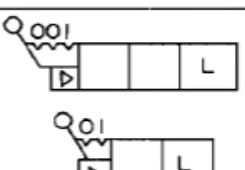
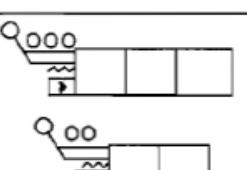
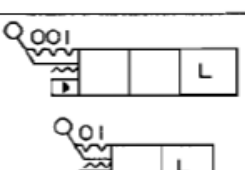
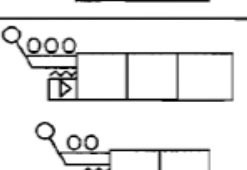
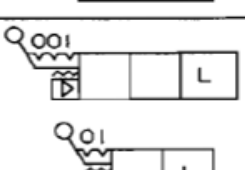
DIMENSIONS IN INCHES

	A max	B max	C min	D max	E max	F max	G max	H max
Double solenoid	11.60	10.40	4.60	7.62	6.88	1.89	3.06	7.62
Single solenoid	11.60	9.40	4.60	7.62	6.88	1.89	3.06	--
Lever	14.00	12.00	4.60	13.88	6.88	1.89	3.06	--
Mechanical	9.00	8.75	4.60	6.88	6.88	1.89	3.06	--

FIGURE 3. Valve envelope.

MIL-DTL-868/3A(SH)

TABLE I. Valve operators-lever.

FIRST CHARACTER	SECOND CHARACTER	
	O	I
LEVER ONLY L		
SPRING RETURN S		
HYD. PILOT H		
PNEU. PILOT P		
SPRING RETURN HYD. PILOT R		
SPRING RETURN PNEU. PILOT Q		

SYMBOLS 'I' AND 'L' INDICATES THE POSITION THAT THE VALVE SPOOL IS LATCHED OR DETENTED.

MIL-DTL-868/3A(SH)

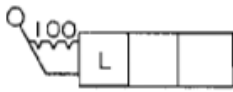

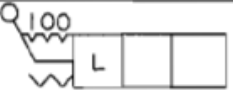
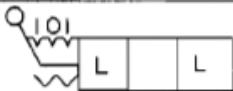
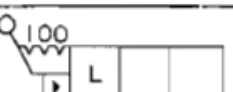
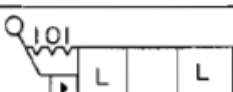
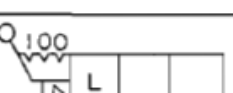
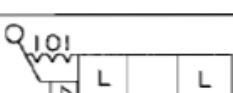
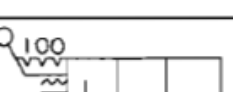
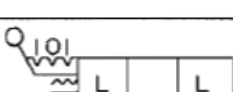
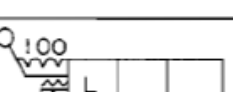
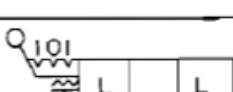
TABLE I. Valve operators-lever – Continued.

FIRST CHARACTER	SECOND CHARACTER	
	2	3
LEVER ONLY L		
SPRING RETURN S		
HYD. PILOT H		
PNEU. PILOT P		
SPRING RETURN HYD. PILOT R		
SPRING RETURN PNEU. PILOT Q		

SYMBOLS '1' AND 'L' INDICATES THE POSITION THAT THE VALVE SPOOL IS LATCHED OR DETENTED.

MIL-DTL-868/3A(SH)

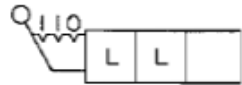








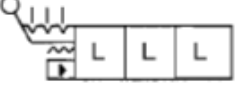


TABLE I. Valve operators-lever – Continued.

FIRST CHARACTER	SECOND CHARACTER	
	4	5
LEVER ONLY L		
SPRING RETURN S		
HYD. PILOT H		
PNEU. PILOT P		
SPRING RETURN HYD. PILOT R		
SPRING RETURN PNEU. PILOT Q		

SYMBOLS "I" AND "L" INDICATES THE POSITION THAT THE VALVE IS LATCHED OR DETENTED.

MIL-DTL-868/3A(SH)

TABLE I. Valve operators-lever – Continued.

FIRST CHARACTER	SECOND CHARACTER	
	6	7
LEVER ONLY L		
SPRING RETURN S		
HYD. PILOT H		
PNEU. PILOT P		
SPRING RETURN HYD. PILOT R		
SPRING RETURN PNEU. PILOT Q		

SYMBOLS 'I' AND 'L' INDICATES THE POSITION THAT THE VALVE
SPOOL IS LATCHED OR DETENTED.

MIL-DTL-868/3A(SH)

TABLE II. Valve operators.

FIRST LETTER	SECOND LETTER (ADDITIONAL OPERATORS)			
	X (NONE)	M (MANUAL)	S (SPRING)	T (SPRG RET MAN OVRRID)
CAM C		NA		NA
ELECTRICAL E				
HYDRAULIC H				
MANUAL M		NA		NA
PNEUMATIC P				
SPRING S		NA	NA	NA
TWO-STAGE T				
WITHOUT OPERATOR X		NA	NA	NA

NOTE:

1. Only listed combinations may be used. NA = Not available.

Example: ES designates a solenoid operated valve with return spring.

H2 designates a manually operated valve with a hydraulic pilot override that is latched or detented in the center spool position.

MIL-DTL-868/3A(SH)

1.1.3 Spool metering or adjustment features. The spool metering or adjustment features are designated by a single character as follows:

- Standard valve with no metering or adjustable flow limiters.
- M Metering valve where flow is proportional to spool displacement. The maximum fluid flow can be limited by adjustable spool stroke limiters (see 2.1.1 and 2.1.2).
- A Adjustable valve where fluid flow can be limited by spool stroke limiters (see 2.1.1).

1.1.4 Spool flow paths. Each valve position flow path shall be designated by a number (or character) in accordance with [table IV](#). A two-position valve is designated by two numbers (or characters) and a three-position valve is designated by three numbers (or characters). Use of more than three characters to designate spool flow paths shall require approval from the Naval Sea Systems Command. See [table V](#) for examples of part numbers.

1.1.5 Right side valve operator. The right side valve operator shall be designated by a two-character code in accordance with [table II](#). The first letter designates the primary operator and the second letter identifies ~~the~~ secondary operators, if any. See 1.1.7 for special operator configurations not covered by [tables I](#) and [II](#).

Example: EM designates a solenoid operated valve with manual override.

SX designates a return spring only.

1.1.6 Fatigue grade. Fatigue rated valves shall conform to the fatigue rated test requirements of MIL-DTL-868. A fatigue rated valve is suitable for use in a non-fatigue rated application. The single letter designates the fatigue requirements grade of the valve as indicated below.

TABLE III. Fatigue grade.

Non-fatigue rated designation	Fatigue rated designation
B	G

MIL-DTL-868/3A(SH)

TABLE IV. Spool flow paths.

CODE	SYMBOL	CODE	SYMBOL	CODE	SYMBOL
0		1		2	
3		4		5	
6		7		8	
9		Z		K	
J					

NOTE:

1. Port orientation shall be as defined herein unless otherwise approved by the Naval Sea Systems Command.

MIL-DTL-868/3A(SH)

1.1.7 Special configuration. Where the required valve configuration cannot be described by the standard designators in [tables I, II, and IV](#), the part number designators will be assigned by the Naval Sea Systems Command following approval of the desired configuration.

1.2 Mounting configuration. The mounting configuration of valves shall be as shown on [figure 1](#).

1.2.1 Fluid connection. The quill or sealing sleeve configuration shown on [figure 2](#) shall be used.

1.2.2 Pilot ports. Ports PPA and PPB, shown on [figure 1](#), are used with valves that require external hydraulic pilot supply to shift the spool. These are valves that have operators which are identified by the letter or character codes H, P, R, and Q from [tables I and II](#).

1.3 Envelope dimensions. Unless otherwise specified (see 6.2 of MIL-DTL-868), the valve assembly shall not exceed the limitations of the envelope dimensions listed on [figure 3](#).

1.4 Solenoids. The solenoids shall be of the direct current type with a rectifier to convert the incoming alternating current to direct current.

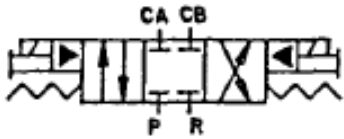
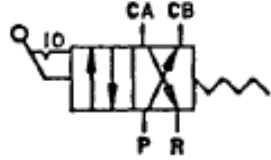
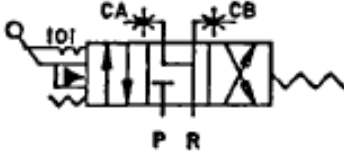
1.5 Hydraulic fluid. The valve shall meet the fluid compatibility requirements specified in MIL-STD-2193 including the immersion test for nonmetallic materials. Fluid in accordance with MIL-PRF-17331 (2190 TEP) or MIL-PRF-17672 (2075-T-H) may be used for the immersion test.

1.6 Test fluid and viscosity. The test fluid shall be either of the two fluids specified in 1.5. Unless otherwise specified for the specific test, the fluid temperature shall be controlled to meet the viscosity requirements identified below. (See MIL-DTL-868 for guidance regarding fluid viscosity at various test temperatures.)

- a. For leakage test, the maximum fluid viscosity at atmospheric pressure shall be 75 centistokes.
- b. For pressure drop tests, hydraulic actuation test, and solenoid actuation tests, the fluid viscosity at atmospheric pressure shall be between 75 and 97 centistokes.
- c. For noise testing, the fluid viscosity at atmospheric pressure shall not exceed 50 centistokes.

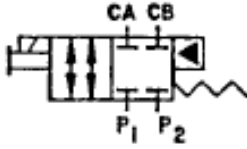
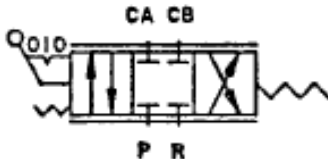
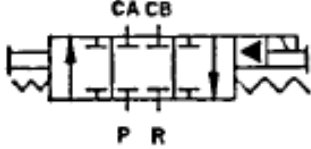
MIL-DTL-868/3A(SH)

TABLE V. Examples of part numbers.

<p>4-WAY, 3-POSITION, DOUBLE SOLENOID, SPRING CENTERED VALVE, WITH CLOSED CENTER SPOOL, MANUAL OVERRIDE. QUIET VALVE OPERATION.</p>  <p>M868/3TT-109TTA</p>
<p>4-WAY, 2-POSITION, MANUAL OPERATED, LATCH IN P TO CA POSITION, SPRING RETURN TO P TO CB POSITION. NON-QUIET VALVE OPERATION.</p>  <p>M868/3L2-19SXB</p>
<p>4-WAY, 3-POSITION, LEVER OPERATED, SPRING CENTERED VALVE FOR NON-QUIET OPERATION. VALVE TO BE EQUIPPED WITH STROKE LIMITERS AND HYDRAULIC OVERRIDE. SPOOL LATCHES IN P TO CA POSITION AND P TO CB POSITION.</p>  <p>M868/3R5A139SXB</p>

MIL-DTL-868/3A(SH)

TABLE V. Examples of part numbers – Continued.

<p>4-WAY, 2-POSITION, SOLENOID OPERATED, QUIET VALVE. MANUAL OVERRIDE TO THE OPEN POSITION, SPRING RETURN TO BLOCKED POSITION. HYDRAULIC PILOT OVERRIDE TO BLOCKED POSITION. (P2 MUST BE LESS THAN OR EQUAL TO 600 PSI.)</p>  <p>M868/3ET-10H5A</p>
<p>4-WAY, 3-POSITION, LEVER OPERATED, SPRING CENTERED, QUIET METERING VALVE. SPOOL LATCHED IN CENTER POSITION. FLOW IS PROPORTIONAL TO SPOOL STROKE.</p>  <p>M868/3S2M109SXA</p>
<p>4-WAY, 3-POSITION, SPRING CENTERED, NON-QUIET VALVE. SOLENOID OPERATED TO DIRECT CB TO R, MANUALLY OPERATED TO DIRECT P TO CA.</p>  <p>M868/3MS-206TTB</p>

MIL-DTL-868/3A(SH)

2. PERFORMANCE

2.1 Flow rate. Valves covered by this specification sheet shall have the following ranges found in [table VI](#):

TABLE VI. Flow rate ranges.

Flow rate (gallons per minute (GPM))
15 - 50
10 - 30 ^{1/}
NOTE: ^{1/} Flow rate range only applicable when noise requirements are specified in the procurement documentation (see 6.2 of MIL-DTL-868).

2.1.1 Flow control adjustment. Valves with flow control adjustments shall be capable of restricting flow to the minimum valves in 2.1, at a minimum differential pressure of 2,200 pounds per square inch gauge (psig) and a viscosity of 50 centistokes maximum at atmospheric pressure.

2.1.2 Differential pressure at rated flow. The differential pressure drop across a valve with the designated spool style at the maximum rated flow listed in 2.1 shall be as follows.

- a. For valves that utilize flow paths 1 and 9 from [table IV](#), the differential pressure across the valve in that position shall not exceed 500 pounds per square inch differential (psid). The pressure differential shall be measured from the pressure port (P) to the return port (R) with the cylinder ports (CA and CB) connected by a piping loop.
- b. For valves that utilize flow paths 2, 3, 5, 6, and Z from [table IV](#), the differential pressure across the valve in that position shall not exceed 250 psid. The pressure differential shall be measured from either the P or R port to either the CA or CB port. The remaining port is blocked.
- c. For valves that utilize flow paths 4, 7, and 8 from [table IV](#), the differential pressure across the valve in that position shall not exceed 250 psid. The pressure differential shall be measured from one of the ports to the other.
- d. For metering valves (spool type M), the valve flow characteristics versus spool displacement shall be within the requirements as specified in [table VII](#).

MIL-DTL-868/3A(SH)

TABLE VII. Metering valve flow.

Percent spool stroke ^{1/}	Percent rated flow at 500 psid	
	maximum	minimum
5	5	0
10	10	2
20	20	5
40	40	16
60	60	32
80	--	50
100	--	100

NOTE:
^{1/} Percent spool stroke can be considered the range in which flow occurs, not the total spool stroke which includes spool/sleeve overlap.

2.2 Solenoid actuation. The solenoid actuation rate specified in MIL-DTL-868 shall be met with the valve at ambient room temperature under the following conditions as specified in [table VIII](#):

TABLE VIII. Solenoid actuation rate.

Condition	Supply pressure (psig)	Return pressure (psig)	Shift time (milliseconds)
1	2,500±100	100±40	500 max
2	1,200 max	100 min	1,500 max

2.3 Mechanical actuation. The force required to operate a mechanically actuated valve shall not exceed 106 pounds-force (471 Newtons) when applied to the valve stem to offset the valve from one position to another for the operating range specified in MIL-DTL-868.

2.4 Leakage. For all [table IV](#) spool flow paths except paths 4 and 8, the maximum allowable leakage from the P port to the R port with the CA and CB ports blocked shall be 0.30 ounces/minute (9 mL/minute). For path 8, the maximum allowable leakage from the CA and CB ports to the R port with the P port blocked shall be 0.30 ounces/minute (9 mL/minute). Leakage across the restricted flow path (orifice) for spool flow paths J and K shall not be less than 0.41 ounces/minute (12 mL/minute) nor more than 1.52 ounces/minute (45 mL/minute).

2.5 Noise. The structureborne noise testing for all applicable valves (see 3.5.5 of MIL-DTL-868) shall be performed in accordance with the requirements specified in MIL-DTL-868 when tested under the following conditions:

2.5.1 Steady state test conditions.

- a. Non-metering valves and valves without stroke limiting adjustment.

Flow - Maximum flow (see 2.1).

Supply pressure - As required to obtain maximum flow.

Return pressure - 60 psig maximum.

- b. Metering valves and valves with stroke limiting adjustments shall be tested for Runs 1, 2, 3, and 4 in [table IX](#). Return pressure shall be 60 psig maximum for all tests. Record values as identified in [table IX](#).

MIL-DTL-868/3A(SH)

TABLE IX. Steady state test conditions for metering valves and valves with stroke limiting adjustment.

Run	Spool position % of full stroke	Flow rate	Differential pressure (psig)
1	As required (record)	Minimum rated	2200+100-0
2	As required (record)	50%	2200+100-0
3	As required (record)	Maximum rated	2200+100-0
4	100%	Maximum rated	≤500 (record)
5	As required (record)	Highest actual	2200+100-0

2.5.2 Transient test conditions.

2.5.2.1 Blocked line test. This test shall be conducted in accordance with MIL-DTL-868.

2.5.2.2 Shift at rated flow. For non-metering valves without stroke limiting adjustments, steady state maximum rated flow as required in **Error! Reference source not found.** shall be achieved. All valves shall meet the shift time and test positions of MIL-DTL-868. For metering valves and valves with stroke limiting adjustments:

- First article testing shall be conducted for the conditions identified in Runs 2, 3 and 5 of [table IX](#).
- Conformance testing shall be conducted for the conditions identified in Run 5 of [table IX](#).

First article testing at flow rates above the highest actual flow shall be for information only.

2.6 Maintainability. The requirements specified in MIL-DTL-868 shall apply.

2.7 Flow sensitivity to viscosity. The viscosity sensitivity of the valve is limited to the parameters tested below. Their requirements must be met for the valve's entire adjustment range at a constant differential pressure. A valve initially set up in accordance with condition (a) below shall meet conditions (b) and (c).

- The flow rate passed through the valve with the supply fluid of a viscosity of 75±5 centistokes (MIL-PRF-17331 (2190 TEP) at 110 °F (43 °C)) shall be considered 100 percent of set flow.
- With a supply fluid of a viscosity of 370 centistokes minimum (MIL-PRF-17331 (2190 TEP) at 60 °F (16 °C)), the valve with a pressure drop, as specified in [table X](#), shall pass no less than the percentage, as specified in [table X](#), of set flow as defined under condition (a). Non-metering valves without stroke limiting adjustment are exempted from the 1,500 and 2,200 psid tests specified in [table X](#).

TABLE X. High viscosity test conditions.

Pressure drop for valves with flow paths 1 and 9 per table IV (psid)	Pressure drop for valves with flow paths 2 through 8 and Z per table IV (psid)	Percentage of set flow
500	250	30%
1,500	1,500	50%
2,200	2,200	60%

- With a supply fluid of a viscosity of 38 centistokes maximum (MIL-PRF-17331 (2190 TEP) at 140 °F (60 °C)), the valve with a pressure drop of 500 psid, for valves of flow paths 1 and 9 per [table IV](#), and 250 psid, for valves of flow paths 2 through 8 and Z per [table IV](#), shall pass no greater than 130 percent of set flow as defined by condition (a).

MIL-DTL-868/3A(SH)

3. CHANGES FROM PREVIOUS ISSUE. Marginal notations are not used in this revision to identify changes with respect to the previous issue due to the extent of the changes.

Preparing activity:
Navy – SH
(Project 4810-2013-004)

NOTE: The activities listed above were interested in this document as of the date of this document. Since organizations and responsibilities can change, you should verify the currency of the information above using the ASSIST Online database at <https://assist.dla.mil>.