

INCH-POUND

MIL-DTL-85633D
15 January 2016
SUPERSEDING
MIL-DTL-85633C
15 January 2005

DETAIL SPECIFICATION

COVERALLS, FLYERS', ANTI-EXPOSURE, CWU-74/P,
CWU-86/P, AND CWU-87/P

This specification is approved for use by all Departments and Agencies of the Department of Defense.

1. SCOPE

1.1 Scope. This specification covers five types of continuous wear anti-exposure flyers' coveralls designated as CWU-74/P, CWU-86/P and CWU-87/P.

1.2 Classification. The coveralls will be one of the following types and sizes as specified (see 6.2).

1.2.1 Types. The types of coveralls are as follows:

Type I - Deleted.

Type II - CWU-74/P, with pockets, wrist seals, and socks, US Air Force application, men's sizing.

Type III - Deleted.

Type IV - CWU-86/P, ruggedized with overvest, pockets, neck seals, and wrist seals, without socks, Naval Air Systems Command application, men's sizing.

Type V - CWU-87/P, ruggedized with overvest, pockets, neck seals, and wrist seals, without socks, Naval Air Systems Command application, women's sizing.

Comments, suggestions, or questions on this document should be addressed to:
Commander, Naval Air Warfare Center Aircraft Division Lakehurst (Code 412000B120-3),
Highway 547, Joint Base MDL, NJ 08733-5100 or emailed to michael.sikora@navy.mil.
Since contact information can change, you may want to verify the currency of this address
information using the ASSIST Online database at <https://assist.dla.mil>.



MIL-DTL-85633D

1.2.2 Sizes. The anti-exposure coverall sizes are as follows:

Types II and IV (Men's Sizing):

Size 1 (32-36)	-	Small-Short
Size 2 (32-36)	-	Small-Regular
Size 3 (32-36)	-	Small-Long
Size 4 (37-40)	-	Medium-Short
Size 5 (37-40)	-	Medium-Regular
Size 6 (37-40)	-	Medium-Long
Size 7 (41-44)	-	Large-Short
Size 8 (41-44)	-	Large-Regular
Size 9 (41-44)	-	Large-Long
Size 10 (45-47)	-	Extra Large-Short
Size 11 (45-47)	-	Extra Large-Regular
Size 12 (45-47)	-	Extra Large-Long

Type V (Women's Sizing):

XSmall	-	Short
XSmall	-	Regular
XSmall	-	Long
XSmall	-	XLong
Small	-	Short
Small	-	Regular
Small	-	Long
Small	-	XLong
Medium	-	Short
Medium	-	Regular
Medium	-	Long
Medium	-	XLong
Large	-	Short
Large	-	Regular
Large	-	Long
Large	-	XLong
Xlarge	-	Short
Xlarge	-	Regular
XLarge	-	Long
XLarge	-	XLong
XXLarge	-	Short
XXLarge	-	Regular
XXLarge	-	Long
XXLarge	-	XLong

MIL-DTL-85633D

2. APPLICABLE DOCUMENTS

2.1 General. The documents listed in this section are specified in sections 3 and 4 of this specification. This section does not include documents cited in other sections of this specification or recommended for additional information or as examples. While every effort has been made to ensure the completeness of this list, document users are cautioned that they must meet all specified requirements of documents cited in sections 3 and 4 of this specification, whether or not they are listed.

2.2 Government documents.

2.2.1 Specifications and standards. The following specifications and standards form a part of this document to the extent specified herein. Unless otherwise specified, the issues of these documents are those cited in the solicitation or contract (see 6.2).

COMMERCIAL ITEM DESCRIPTIONS

A-A-50195	-	Thread, Aramid
A-A-55126	-	Fastener Tapes, Hook and Loop, Synthetic
A-A-55634	-	Zippers (Fasteners, Slide Interlocking)

DEPARTMENT OF DEFENSE SPECIFICATIONS

MIL-DTL-32075	-	Label: For Clothing, Equipage, and Tentage, (General Use)
MIL-DTL-32149	-	Cloth, Waterproof and Moisture Vapor Permeable, Flame Resistant
MIL-C-83429	-	Cloth, Plain and Basket Weave, Aramid
MIL-W-85635	-	Water Test Device, Anti-Exposure Coverall

(Copies of these documents are available online at <http://quicksearch.dla.mil/> or <https://assist.dla.mil/>.)

2.2.2 Other Government documents, drawings, and publications. The following other Government documents, drawings, and publications form a part of this document to the extent specified herein. Unless otherwise specified, the issues are those cited in the solicitation or contract.

NAVAL AIR SYSTEMS COMMAND

NAWC Purchase Description (PD) 4673-11-01	Cloth, Woven, Twill, Flame Resistant
---	--------------------------------------

(Copies of this purchase description are available from the Naval Air Warfare Center, Code 4.6.7, 48810 Shaw Road, Building 2187, Patuxent River, MD 20670.)

MIL-DTL-85633D

Type II (CWU-74/P COVERALLS)

NAVAL AIR SYSTEMS COMMAND

- 1370AS403 - Coveralls, Flyers', Anti-Exposure, CWU-74/P
- 1370AS404 - Coveralls, Subassembly, Anti-Exposure, Flyers' PTFE, Constant Wear
- 1370AS502 - Seam Tape and Patches, Heat Sealable Anti-Exposure Coverall, CWU-74/P
- 1370AS706 - Wrist and Neck Seal Pattern, Sizes 1 thru 12, CWU-74/P Anti-Exposure Coverall
- 3769AS103 - Zipper, Omni-Environment Barrier

Type IV (CWU-86/P COVERALLS)

NAVAL AIR SYSTEMS COMMAND

- 1370AS502 - Seam Tape and Patches
- 3769AS100 - Coveralls Assembly, Flyers' Anti-Exposure, Ruggedized, CWU-86/P
- 3769AS101 - Coveralls, Flyers' Anti-Exposure, Ruggedized, CWU-86/P
- 3769AS102 - Overvest Subassembly, Flyers' Anti-Exposure, Ruggedized, CWU-86/P
- 3769AS103 - Zipper, Omni-Environment Barrier, Anti-Exposure
- 3769AS105 - Pockets, Subassembly, Flyers' Anti-Exposure, Ruggedized, CWU-86/P & CWU-87/P
- 3769AS110 - Seal, Neck, Flyers' Anti-Exposure, Ruggedized, CWU-86/P & CWU-87/P
- 3769AS111 - Seal, Neck, Gasket Anti-Exposure, CWU-86/P & CWU-87/P
- 3769AS120 - Seal, Wrist, Flyers' Anti-Exposure, Ruggedized, CWU-86/P & CWU-87/P

Type V (CWU-87/P COVERALLS)

NAVAL AIR SYSTEMS COMMAND

- 1370AS502 - Seam Tape and Patches
- 3769AS103 - Zipper, Omni-Environment Barrier, Anti-Exposure
- 3769AS105 - Pockets, Subassembly, Flyers' Anti-Exposure, Ruggedized, CWU-86/P & CWU-87/P
- 3769AS110 - Seal, Neck, Flyers' Anti-Exposure, Ruggedized, CWU-86/P & CWU-87/P
- 3769AS111 - Seal, Neck, Gasket Anti-Exposure, CWU-86/P & CWU-87/P
- 3769AS120 - Seal, Wrist, Flyers' Anti-Exposure, Ruggedized, CWU-86/P & CWU-87/P

MIL-DTL-85633D

- 3769AS200 - Coveralls Assembly, Flyers' Anti-Exposure, Ruggedized, CWU-87P
- 3769AS201 - Coveralls, Flyers' Anti-Exposure, Ruggedized, CWU-87P
- 3769AS202 - Overvest Subassembly, Coveralls, Flyers' Anti-Exposure, Ruggedized, CWU-87/P

(Copies of these drawings are available online at <http://ct.dscp.dla.mil/contracting/>.)

2.3 Non-Government publications. The following documents form a part of this document to the extent specified herein. Unless otherwise specified, the issues of these documents are those cited in the solicitation or contract.

AMERICAN SOCIETY FOR QUALITY (ASQ)

- ASQ-Z1.4 - Procedures, Sampling and Tables for Inspection by Attributes (DoD adopted)

(Copies of this document are available from www.asq.org.)

AMERICAN SOCIETY FOR TESTING MATERIALS (ASTM) INTERNATIONAL

- ASTM-D6193 - Stitches and Seams, Standard Practice for (DoD adopted)

(Copies of these documents are available from www.astm.org.)

NATIONAL AEROSPACE STANDARDS COMMITTEE (NAS)

- NASM43770-1 - Snap Hooks, Wire Body, Fixed Loop Eye, Flat Spring Closure, with Retainer

(Copies of this document are available from www.aia-aerospace.org.)

2.4 Order of precedence. Unless otherwise noted herein or in the contract, in the event of a conflict between the text of this document and the references cited herein, the text of this document takes precedence. Nothing in this document, however, supersedes applicable laws and regulations unless a specific exemption has been obtained.

3. REQUIREMENTS

3.1 Qualification. The anti-exposure coveralls furnished under this specification shall be products that are authorized by the qualifying activity for listing on the applicable qualified products list before contract award (see 4.2 and 6.3). Qualification of any one type and size of coverall under this specification shall automatically qualify a supplier for all types and all sizes specified herein.

MIL-DTL-85633D

3.2 First article. When specified (see 6.4), a sample shall be subjected to first article inspection in accordance with 4.3.

3.3 Recycled, recovered, or environmentally preferable materials. Recycled, recovered, or environmentally preferable materials should be used to the maximum extent possible provided that the material meets or exceeds the operational and maintenance requirements, and promotes economically advantageous life cycle costs.

3.4 Materials and components. Unless otherwise specified, the materials and components shall have been manufactured not greater than eighteen months prior to the date of delivery of the anti-exposure coverall.

3.4.1 Laminated cloth (Types II, IV, and V). The base cloth for types II, IV, and V coveralls shall conform to MIL-DTL-32149.

3.4.2 Flame resistant cloth, twill. The flame resistant woven cloth for the expansion panel shall conform to NAWC Purchase Description 4631-11-01. The color shall be green 3438.

3.4.3 Aramid cloth (Types IV and V). The aramid cloth for the overvest, pockets, and pocket tabs shall be a flame resistant, high strength aramid fiber blend conforming to MIL-C-83429, type II, class 6. The color shall be green 3438 (equivalent to AF 1590).

3.4.4 Heat seal cloth (Types IV and V). The heat seal cloth for the seat and knee reinforcement shall conform to Drawing 1370AS502, part number 1370AS502-5.

3.4.5 Zippers.

3.4.5.1 Entry and portal zippers. The entry zipper and portal zipper, as applicable, shall be an omni-environmental type conforming to Drawing 3769AS103 (see 6.6.1).

3.4.5.2 Zipper thong or tether.

3.4.5.2.1 Zipper thong and tether (Type V).

3.4.5.2.1.1 Zipper thong (Type V). The entry zipper shall have an attached thong conforming to Drawing 3769AS101.

3.4.5.2.1.2 Detachable tether (Type V). The entry zipper shall have a detachable tether. The tether shall be cut from aramid cloth specified in 3.4.4. One end shall be attached to a spring closure snap hook as specified in 3.4.9. The other end of the cloth shall be finished to prevent raveling or fraying. The tether shall finish $\frac{3}{8}$ - to $\frac{1}{2}$ -inch wide and 42 inches long $\pm \frac{1}{4}$ -inch when attached to the zipper pull.

3.4.5.3 Pockets and overvest zippers (Types IV and V).

MIL-DTL-85633D

3.4.5.3.1 Pencil pocket. The zipper for the pencil pocket shall conform to A-A-55634, type I, style 7, 6-1/2 inches long (see 6.6.2).

3.4.5.3.2 Calf pocket. The zipper for the calf pocket shall conform to A-A-55634, type I, style 4, 9 inches long (see 6.6.2).

3.4.5.3.3 Overvest zipper. The zipper for the overvest shall conform to A-A-55634, type I, style 4 (see 6.6.2). The zipper lengths shall be as follows:

<u>Men's Size</u>	<u>Type IV</u>	<u>Women's Size</u>	<u>Type V</u>
S	8 inches	XS	8 inches
M	8 inches	S	8 inches
L	9 inches	M	9 inches
XL	9 inches	L	9 inches
		XL	10 inches
		XXL	11 inches

3.4.6 Fastener tapes (Types IV and V). The hook and loop fastener tape shall be 3/4-inch wide and 2 inches wide and shall conform to A-A-55126, type II, class 1. The color of the hook and loop tape shall match the laminated cloth.

3.4.7 Thread. The thread for stitching the coverall shall be a 60 tex, aramid thread conforming to A-A-50195. The color shall match the appropriate laminated cloth in 3.4.1 or 3.4.2.

3.4.8 Snap hook. The snap hook for the type V tether shall be in accordance with NASM 43770-1.

3.5 Labels.

3.5.1 Identification label. The coveralls shall have a combination size, identification, and instruction label conforming to MIL-DTL-32075, type VI, class 14. The label can be in one or two pieces. If two pieces are used the warning and caution statements shall be placed on the second label and the second label shall be located directly below the first label. The label shall also include the following information in 10 point type (see 6.7):

CWU-XX/P (XX will be 74 for Type II or 86 for Type IV or 87 for Type V))

Anti-Exposure Flyers Coverall (For Type II)

Anti-Exposure Flyers Ruggedized Coverall (For Types IV and V)

Size (Types II and IV only)

Size (see 3.5.2) Height (see 3.5.2) Hip Size (see 3.5.2) (Type V only)

Name of Manufacturer and CAGE Code

Contract or Order Number

NSN (see 6.2)

Date of manufacture (month/year)

Serial Number (see 3.5.3)

MIL-DTL-85633D

CAUTION. (10 point). Machine wash cold with powdered detergent. Drip or tumble dry low.

DO NOT DRY CLEAN

REMOVE WATCHES AND JEWELRY BEFORE DONNING AND DOFFING.

Coverall cloth can be damaged. Sharp instruments can puncture or abrade surfaces. Use care when donning or doffing. Ensure zippers are securely closed after donning.

3.5.2 Size markings (Type V only). The size information in table I shall be used on the identification label (see 3.5.1).

TABLE I. Size marking chart.

Size	Height (inches)	Hip Size (inches)
Small-Short	< 64.5	< 36
Small-Regular	64.5 – 67.5	< 36
Small-Long	> 67.5	< 36
Medium-Short	< 64.5	36 – 40
Medium-Regular	64.5 – 67.5	36 – 40
Medium-Long	> 67.5	36 – 40
Large-Short	< 64.5	> 40
Large-Regular	64.5 – 67.5	> 40
Large-Long	> 67.5	> 40

3.5.3 Serial numbers. The coveralls shall be identified by individual serial numbers which shall be assigned by the manufacturer. Serialization shall be by a block of consecutive numbers to cover the entire acquisition document quantity.

3.6 Design.

3.6.1 Type II (CWU-74/P). The design of the type II coveralls shall conform to the requirements of applicable drawings (see 2.2.2). The coveralls shall be a one piece garment containing a neck seal, wrist seals, pockets, socks, and an omni-environmental barrier entry and a portal zipper (see figure 1).

3.6.2 Type IV (CWU-86/P). The design of the type IV coveralls shall conform to the requirements of the applicable drawings (see 2.2.2). The coverall shall be a one piece garment containing a neck seal, wrist seals, an omni-environmental barrier entry and a portal zipper, overvest, and pockets (see figures 2 and 3).

3.6.3 Type V (CWU-87/P). The design of the type V coveralls shall conform to the requirements of the applicable drawings (see 2.2.2). The coverall shall be a one piece garment

MIL-DTL-85633D

containing a neck seal, wrist seals, omni-environmental barrier entry zipper, overvest, and pockets (see figures 4 and 5).

3.7 Construction. The coveralls shall be constructed in accordance with Drawings 1370AS403 and 1370AS404 for Type II; 3769AS100 for Type IV; 3769AS200 for Type V using sewn seams covered on the inside of the coverall by heat sealed tapes.

3.8 Patterns. The Government furnished patterns for use in cutting working patterns (see 6.5) shall not be altered in any way. The Government furnished patterns shall be used as a guide for making the contractor's working patterns. Minor modifications of the contractor's working patterns are permitted when using automated equipment or to accommodate a manufacturer's process but the alterations shall not affect the serviceability, dimensions, or appearance of the coverall.

3.8.1 List of pattern parts. The pattern parts and cutting quantities for the coverall shall be as specified in table II (see 6.5.1).

TABLE II. List of pattern parts.

COVERALL TYPE	MATERIAL	PATTERN NOMENCLATURE	COMPUTER NOMENCLATURE	CUT PARTS
II	Laminated cloth	Back Torso	---	1
	Laminated cloth	Top Sleeve	---	2
	Laminated cloth	Under Sleeve	---	2
	Laminated cloth	Back Leg	---	2
	Laminated cloth	Front Torso	---	2
	Laminated cloth	Pencil Pocket Flap	---	1
	Laminated cloth	Breast Pocket	---	2
	Laminated cloth	Pencil Pocket	---	1
	Laminated cloth	Right Thigh Pocket	---	1
	Laminated cloth	Lower Leg Pocket	---	2
	Laminated cloth	Breast Pocket Cover	---	2

MIL-DTL-85633D

TABLE II. List of pattern parts - Continued.

COVERALL TYPE	MATERIAL	PATTERN NOMENCLATURE	COMPUTER NOMENCLATURE	CUT PARTS
II Continued	Laminated cloth	Lower Thigh Pocket Cover	---	1
	Laminated cloth	Right Leg Pocket Cover	---	2
	Flame resistant cloth	Expansion Panel	---	1
IV	Laminated cloth	Front	FRONT_IV	2
	Laminated cloth	Back Torso	BK_TORSO_IV	1
	Laminated cloth	Back Leg	BACK_LEG_IV	2
	Laminated cloth	Sleeve	SLEEVE_IV	2
	Laminated cloth	Sock Attachment Panel	SOCKAHPL_IV	2
	Laminated cloth	Knife Pocket Reinforcement	KNIFEPKTRNF	1
	Aramid	Collar	COLLAR_IV	1
	Aramid	Collar Interlining	CLLRINT_IV	1
	Aramid	Knife Pocket Backing	KPKTBKNG_IV	1
	Aramid	Overvest Back	OV_BACK_IV	1
	Aramid	Overvest Front Facing	OV_FRTFC_IV	2
	Aramid	Overvest Flap	OV_FLAP_IV	1
	Aramid	Overvest Front Left	OVLFRONT_IV	1
	Aramid	Overvest Front Right	OVRFRONT_IV	1
	Aramid	Yoke	OV_YOKE_IV	2

MIL-DTL-85633D

TABLE II. List of pattern parts - Continued.

COVERALL TYPE	MATERIAL	PATTERN NOMENCLATURE	COMPUTER NOMENCLATURE	CUT PARTS
IV Continued	Aramid	Calf Pocket	CALF_PKT	2
	Aramid	Calf Pocket Upper	CALF_PKTUPR	2
	Aramid	Glove Pocket	GLOVE_PKT	2
	Aramid	Knife Pocket	KNIFE_PKT	1
	Aramid	Sleeve Cuff	SLEEVE_CUFF	2
	Aramid	Pencil Pocket Flap	PEN_PKT_FLP	1
	Aramid	Left Sleeve Pocket	LSLEEVE_PKT	1
	Aramid	Pencil Pocket	PENCIL_PKT	1
	Aramid	Left Sleeve Pocket Side	LSLV_PKTSD	1
	Aramid	Cuff Adjustment Tab	CUFF_ADJTAB	2
	Aramid	Thong	THONG	1
	Aramid	Pocket tab	PKTTAB	1
	Flame resistant cloth, twill	Back Expansion Panel	BKEXPPNL_IV	1
	Heat Seal cloth	Knee Reinforcement Panel	KNEERFPL_IV	2
	Heat Seal cloth	Seat Reinforcement Panel	SEATRFPL_IV	2

MIL-DTL-85633D

TABLE II. List of pattern parts - Continued.

COVERALL TYPE	MATERIAL	PATTERN NOMENCLATURE	COMPUTER NOMENCLATURE	CUT PARTS
IV Continued	Guide	Undercollar Stitching	G_UCLRST_IV	0
	Guide	Left Front	G_LFRONT_IV	0
	Guide	Right Front	G_RFRONT_IV	0
	Guide	Left Sleeve	G_L_SLV_IV	0
	Guide	Right Sleeve	G_R_SLV_IV	0
V	Laminated cloth	Front	FRONT_V	2
	Laminated cloth	Back Top	BACK_TOP_V	1
	Laminated cloth	Back Leg	BACK_LEG_V	2
	Laminated cloth	Sleeve	SLEEVE_V	2
	Laminated cloth	Sock Attachment Panel	SOCKATHPL_V	2
	Laminated cloth	Knife Pocket Reinforcement	KNIFEPKTRNF	1
	Laminated cloth	Gusset Inner	GUSSETINR_V	2
	Aramid	Collar	COLLAR_V	1
	Aramid	Collar Interlining	CLLR_INT_V	1
Aramid	Knife Pocket Backing	KPKTBKNG_V	1	

MIL-DTL-85633D

TABLE II. List of pattern parts - Continued.

COVERALL TYPE	MATERIAL	PATTERN NOMENCLATURE	COMPUTER NOMENCLATURE	CUT PARTS
V Continued	Aramid	Overvest Back Left	OV_BACK_L_V	1
	Aramid	Overvest Back Right	OV_BACK_R_V	1
	Aramid	Overvest Facing	OV_FRT_FC_V	2
	Aramid	Overvest Flap	OV_FLAP_V	2
	Aramid	Overvest Front Left	OV_FRT_L_V	1
	Aramid	Overvest Front Right	OV_FRT_R_V	1
	Aramid	Overvest Yoke	OV_YOKE_V	2
	Aramid	Calf Pocket	CALF_PKT	2
	Aramid	Calf Pocket Upper	CALF_PKTUPR	2
	Aramid	Glove Pocket	GLOVE_PKT	2
	Aramid	Knife Pocket	KNIFE_PKT	1
	Aramid	Sleeve Cuff	SLEEVE_CUFF	2
	Aramid	Pencil Pocket Flap	PEN_PKT_FLP	1
	Aramid	Left Sleeve Pocket	LSLEEVE_PKT	1
	Aramid	Pencil Pocket	PENCIL_PKT	1

MIL-DTL-85633D

TABLE II. List of pattern parts - Continued.

COVERALL TYPE	MATERIAL	PATTERN NOMENCLATURE	COMPUTER NOMENCLATURE	CUT PARTS
V Continued	Aramid	Left Sleeve Pocket Side	LSLV_PKTSD	1
	Aramid	Cuff Adjustment Tab	CUFF_ADJTAB	2
	Aramid	Thong	THONG	1
	Aramid	Pocket tab	PKTTAB	1
	Flame resistant cloth	Gusset Outer	GUSSETOTR_V	2
	Heat Seal cloth	Knee Reinforcement Panel	KNEERFPL_V	2
	Heat Seal cloth	Seat Reinforcement Panel	SEATRNFPL_V	2
	Guide	Undercollar Stitching	G_UCLRSTH_V	0
	Guide	Left Front	G_LFRONT_V	0
	Guide	Right Front	G_RFRONT_V	0
	Guide	Left Sleeve	G_L_SLV_V	0
	Guide	Right Sleeve	G_R_SLV_V	0

3.9 Cutting. All fabric pieces shall be cut in accordance with the patterns. If no directional line is given on the pattern the long dimension of the pieces shall be cut in the direction of the fabric warp.

3.10 Marking. Cut parts shall be marked, ticketed, or bundled to ensure a uniform size throughout the coverall. Any method of marking shall be used except metal fastening devices, sewn on tickets, or adhesive type tickets that leave traces of adhesive on the material after removal of the ticket. Drill holes may be used to mark the lay only in areas where the drill marks will be buried within a seam and covered by seam tape.

3.11 Stitches, seams, and stitching. Unless otherwise specified, ASTM D6193 stitch types 301 and 401, with 8 to 10 stitches per inch shall be used in the construction of the coveralls. Seams shall be as specified in construction drawings (see 3.7).

MIL-DTL-85633D

3.11.1 Dimensional tolerances. Unless otherwise specified, the tolerances for all drawings, patterns, and operations shall be as specified in table III.

TABLE III. Dimension tolerances.

Dimension	Tolerance
¼ inch or under	± 1/32 inch
¼ inch or more but less than ¾ inch	± 1/16 inch
¾ inch or more but less than 1½ inches	± 3/32 inch
1½ inches or more but less than 3 inches	± 1/8 inch
3 inches or more but less than 5 inches	± 3/16 inch
5 inches or more but less than 10 inches	± ¼ inch
10 inches or more but less than 30	± 3/8 inch
30 inches to more	± 5/8 inch

3.12 Heat sealing. All sewn seams and stitching shall be covered on the inside of the coverall and sealed with the seam tape. The entire width of the seam tape shall be heat sealed over the seams and stitching. Crossover areas and ends left unsealed after heat sealing shall be taped. To maintain a tape overlap, sealed sewn seams shall not contain more than two layers of seam tape per seam. The tape shall not lift from the seam at any point. The neck and wrist seals attaching seams to the coverall shall be covered on the inside of the coveralls. End joints where the tape passes over taped seams on the coveralls shall be avoided. The overlap of splicings and tape ends shall be not less than ¾ inch.

3.12.1 Patches for mending. The coveralls shall contain no more than three mending patches. Patching of fabrication defects shall be permitted by a 2-inch diameter patch (see Drawing 1370AS502) on the inside of the coveralls and of a color to match the color of the backing cloth. Patches shall be applied at a temperature of 350 °F for 20 seconds at 75 ±2 ft. lbs. pressure. When patching is used it shall be noted on the inspection form (see figures 6 and 7). The patched area shall not leak (see 3.14).

3.13 Finished garment dimensions. The finished garment dimensions shall be as specified in tables IV through VI, as applicable. The garment shall lie flat with the zipper fully closed when measuring. Locations A through N are shown on figures 2, 3, 4, and 5. Do not stretch knit at any time during garment measurement.

MIL-DTL-85633D

TABLE IV. Type II - CWU-74/P finished garment dimensions (inches).

SIZE	CHEST WIDTH A	SLEEVE LENGTH B	FRONT TORSO LENGTH C	INSEAM LENGTH D
1 (32-36)	14 ⁷ / ₈	19 ³ / ₈	26	27
2 (32-36)	15	20 ³ / ₈	26 ⁵ / ₈	28 ⁵ / ₈
3 (32-36)	15 ³ / ₈	21 ⁷ / ₈	28 ¹ / ₄	31
4 (37-40)	17 ¹ / ₄	20 ¹ / ₈	28 ⁷ / ₈	27
5 (37-40)	17 ³ / ₈	20 ⁷ / ₈	29 ³ / ₄	28 ⁵ / ₈
6 (37-40)	17 ¹ / ₂	21 ⁷ / ₈	30	31
7 (41-44)	18 ³ / ₄	20 ³ / ₈	28 ¹ / ₈	27
8 (41-44)	19 ³ / ₈	21 ³ / ₈	30 ³ / ₄	28 ⁵ / ₈
9 (41-44)	19 ⁵ / ₈	22	31	31
10 (45-47)	21 ¹ / ₄	19 ¹ / ₂	29 ³ / ₄	27
11 (45-47)	21 ³ / ₈	21	30 ¹ / ₈	28 ⁵ / ₈
12 (45-47)	21 ⁵ / ₈	22 ¹ / ₄	32	31
Tolerance	± 1	± ⁵ / ₈	± 1	± 1

A - The chest width shall be measured above the zipper from edge to edge at the underarm seam.

B - The sleeve length shall be measured along the top seam of the back sleeve from the armscye seam to the edge of the sleeve.

C - The front torso length shall be measured along the center front seam from the edge of the neck seal seam to the edge of the material at the crotch. The measuring tape shall be placed to the right side of the relief portal zipper.

D - The inseam shall be measured along the seam from the edge of the crotch seam to the bottom edge of the leg.

TABLE V. Type IV - CWU-86/P finished garment dimensions (inches).

SIZE	CHEST WIDTH	SLEEVE LENGTH	FRONT TORSO LENGTH	INSEAM LENGTH	YOKE WIDTH	CALF POCKET BOX DEPTH	ZIPPER FLAP LENGTH	COLLAR LENGTH
	A	B	C	D	K	L	M	N
Small / Short	21 ¼	22 ¼	23 ½	30 ½	13 ¾	2 ¼	9 ¼	18
Small / Regular	21 ¼	23 ¾	25 ½	33	13 ¾	2 ¼	9 ¼	18
Small / Long	21 ¼	24 ¾	27	34 ½	13 ¾	2 ¼	9 ¼	18
Medium / Short	23	22 ¾	24 ¾	30 ½	15 ½	2 ¼	9 ⅞	18 ½
Medium / Regular	23	23 ⅞	26 ¾	33	15 ½	2 ¼	9 ⅞	18 ½
Medium / Long	23	24 ⅞	28 ¼	34 ½	15 ½	2 ¼	9 ⅞	18 ½
Large / Short	25	22 ⅝	26	30 ½	17 ½	2 ¼	10 ½	19 ¼
Large / Regular	25	24 ⅛	28	33	17 ½	2 ¼	10 ½	19 ¼
Large / Long	25	25 ⅛	29 ½	34 ½	17 ½	2 ¼	10 ½	19 ¼
X-Large Short	27 ½	23	27 ¼	30 ½	20	2 ¼	11 ⅛	20
X-Large Reg	27 ½	24 ½	29 ¼	33	20	2 ¼	11 ⅛	20
X-Large Long	27 ½	25 ½	30 ¾	34 ½	20	2 ¼	11 ⅛	20
Tolerance	± 1	± ⅝	± 1	± 1	± ⅜	± ⅛	± ¼	± ⅜

- A - The chest width shall be measured above the zipper from edge to edge at the underarm seam.
- B - The sleeve length shall be measured along the inseam sleeve from the armhole seam to the finished edge of the cuff.
- C - The front torso length shall be measured along the center front seam from the edge of the neck seal seam to the edge of the material at the crotch. The measuring tape shall be placed to the right side of the relief portal zipper.
- D - The inseam shall be measured along the seam from the edge of the crotch seam to the bottom edge of the leg.
- K - The yoke cross back width shall be measured along the yoke stitchline, between armhole finished edges.
- L - The calf pocket box depth shall be measured with the lower, rear corner of the calf pocket pulled out to its fullest volume. Measure the depth.
- M - The overvest zipper flap length shall be measured from the topmost folded edge of the flap to its termination in the yoke attachment seam.
- N - The collar length shall be measured with the overvest unzipped and the coverall neckline tucked into coverall body. Measurement of the collar shall be approximately 1 inch above and parallel to the neckline seam.

TABLE VI. Type V - CWU-87/P finished garment dimensions (inches).

SIZE	CHEST E	HIP F	CENTER BACK LENGTH G	SLEEVE LENGTH W/CUFF H	INSEAM LENGTH J	YOKE ACROSS BACK K	CALF POCKET DEPTH L	ZIPPER FLAP LENGTH M	COLLAR LENGTH N
X-Small / Short	37 ½	33	16	27 ½	27 ½	15 ½	2 ¼	9 ½	16 ¼
X-Small / Regular	37 ½	33	17	29	29 ½	15 ½	2 ¼	9 ½	16 ¼
X-Small / Long	37 ½	33	18	30 ½	31 ½	15 ½	2 ¼	9 ½	16 ¼
X-Small / X-Long	37 ½	33	19	32	33 ½	15 ½	2 ¼	9 ½	16 ¼
Small / Short	39	37	17	28	27 ½	16	2 ¼	10	17 ¼
Small / Regular	39	37	18	29 ½	29 ½	16	2 ¼	10	17 ¼
Small / Long	39	37	19	31	31 ½	16	2 ¼	10	17 ¼
Small / X-Long	39	37	20	32 ½	33 ½	16	2 ¼	10	17 ¼
Medium / Short	42 ½	41	18	28 ½	27 ½	16 ½	2 ¼	10 ½	18 ¾
Medium / Regular	42 ½	41	19	30	29 ½	16 ½	2 ¼	10 ½	18 ¾
Medium / Long	42 ½	41	20	31 ½	31 ½	16 ½	2 ¼	10 ½	18 ¾
Medium / X-Long	42 ½	41	21	33	33 ½	16 ½	2 ¼	10 ½	18 ¾
Large / Short	46	45	19	29	27 ½	17	2 ¼	11 ¼	19
Large / Regular	46	45	20	30 ½	29 ½	17	2 ¼	11 ¼	19
Large / Long	46	45	21	32	31 ½	17	2 ¼	11 ¼	19
Large / X-Long	46	45	22	33 ½	33 ½	17	2 ¼	11 ¼	19
X-Large / Short	47 ½	49	20	24 ½	27 ½	17 ½	2 ¼	12 ⅛	19 ¾
X-Large / Regular	47 ½	49	21	31	29 ½	17 ½	2 ¼	12 ⅛	19 ¾
X-Large / Long	47 ½	49	22	32 ½	31 ½	17 ½	2 ¼	12 ⅛	19 ¾
X-Large / X-Long	47 ½	49	23	34	33 ½	17 ½	2 ¼	12 ⅛	19 ¾
XX-Large / Short	49	53	21	30	27 ½	18	2 ¼	13	20 ½

TABLE VI. Type V - CWU-87/P finished garment dimensions (inches) - Continued.

SIZE	CHEST	HIP	CENTER BACK LENGTH	SLEEVE LENGTH W/CUFF	INSEAM LENGTH	YOKE ACROSS BACK	CALF POCKET DEPTH	ZIPPER FLAP LENGTH	COLLAR LENGTH
	E	F	G	H	J	K	L	M	N
XX-Large / Regular	49	53	22	31 ½	29 ½	18	2 ¼	13	20 ½
XX-Large / Long	49	53	23	33	31 ½	18	2 ¼	13	20 ½
XX-Large / X-Long	49	53	24	34 ½	33 ½	18	2 ¼	13	20 ½
Tolerances	+ 1/-½	+ 1/-½	± ½	± ⁵ / ₈	± 1	± ³ / ₈	± ¹ / ₈	± ¼	± ³ / ₈

- E - The chest shall be measured from folded edge to folded edge at underarm seam including knit inserts. Double the measurement.
- F - The hip shall be measured from folded edge to folded edge at the bottom of expansion panel inserts. Double the measurement.
- G - The center back length shall be measured from center back neck edge to waist seam along edge of zipper.
- H - The sleeve length shall be measured along topmost folded edge from neck edge of the garment to sleeve bottom. (Does not include the neck seal.)
- J - The leg inseam length shall be measured along inner leg seam from middle of zipper to bottom of leg.
- K - The yoke cross back width shall be measured along the yoke stitchline, between armhole finished edges.
- L - The calf pocket box depth shall be measured with the lower, rear corner of the calf pocket pulled out to its fullest volume. Measure the depth.
- M - The overvest zipper flap length shall be measured from the topmost folded edge of the flap to its termination in the yoke attachment seam.
- N - The collar length shall be measured with the overvest unzipped and the coverall neckline tucked into coverall body. Measurement of the collar shall be 1 inch above and parallel to the neckline seam.

MIL-DTL-85633D

3.14 Performance requirements.

3.14.1 End item coverall leakage. The anti-exposure coveralls shall not leak. A wax pencil shall be used for all marking and there shall not be any evidence of construction or material failure in any respect when tested as specified in 4.5.3. The inspection form shall be filled out (see figures 6 and 7).

3.15 Protective storage requirements. Each coverall shall be neatly folded in accordance with figure 13 using tissue paper in the fold areas to preclude sharp creases from forming. The folded coveralls shall be inserted into a waterproof bag that is double folded at the end and sealed using two-inch general purpose masking tape. The bag shall not be heat sealed.

3.16 Workmanship. The finished coveralls shall be uniform in quality and free from loose thread, foreign matter, and irregular defects that can adversely affect usage or durability.

4. VERIFICATION

4.1 Classification of inspections. The inspection requirements specified herein are classified as follows:

- a. Qualification inspection (see 4.2).
- b. First article inspection (see 4.3).
- c. Conformance inspection (see 4.4).

4.2 Qualification inspection. The qualification inspection of the coveralls shall consist of the examinations and tests specified in 4.5.1 through 4.5.3.

4.2.1 Qualification samples. The qualification samples shall consist of three coveralls of types II or IV (see 3.1); one each of Size 1, 6, and 12 or three coveralls of type V; one each size Small/Regular, Medium/Short, Large/Long.

4.3 First article inspection. First article inspection shall consist of the examinations and tests specified in 4.5.1 through 4.5.3.

4.3.1 First article samples. The number of samples for first article inspection shall be specified in the contract (see 6.2). The first article samples shall include one coverall of each size ordered. The sample unit shall be one coverall and the lot size shall be expressed in units of coveralls.

4.4 Conformance inspection. Conformance inspection shall consist of the examinations and tests specified in 4.5.1 through 4.5.3.

MIL-DTL-85633D

4.4.1 Conformance inspection samples. Sampling for conformance inspection shall be performed in accordance with ASQ-Z1.4 (see 6.2). The sample unit shall be one coverall and the lot size shall be expressed in units of coveralls.

4.5 Examinations and tests.

4.5.1 Material and component inspection. Materials and components shall be examined and tested in accordance with table VII.

TABLE VII. Materials and components examinations and tests.

MATERIAL OR COMPONENT	REQUIREMENT PARAGRAPH	EXAMINATIONS AND TESTS
Laminated cloth (Types IV and V)	3.4.1	All examinations and tests specified in MIL-DTL-32149
Flame resistant cloth	3.4.2	All examinations and tests specified in NAWC PD 4673-11-01
Aramid cloth (Types IV and V)	3.4.3	All examinations and tests specified in MIL-C-83429
Heat seal cloth (Types IV and V)	3.4.4	All examinations and tests specified in 1370AS502
Zippers	3.4.5	All examinations and tests specified in 3769AS103 and A-A-55634 as applicable
Fastener tape (Types IV and V)	3.4.6	All examinations and tests specified in A-A-55126
Thread	3.4.7	All examinations and tests specified in A-A-50195
Snap Hook	3.4.8	All examinations and tests specified in NASM43770

4.5.2 End item inspection. The end item shall be visually examined, measured and tested as specified herein.

4.5.2.1 Classification of end item defects. The end items shall be examined for the defects listed in table VIII.

MIL-DTL-85633D

TABLE VIII. Classification of end item defects.

EXAMINE	DEFECT	CLASSIFICATION		
		CRITICAL	MAJOR	MINOR
GENERAL	Any hole, scissor or knife tear, mend, burn, or weakening defect such as multiple floats, slubs, skips, needle chew or abraded area.	1		
	Any evidence of fabric delamination.	2		
	Any spot or stain (compound, oil, dirt, incl marks) clearly visible. <u>1/</u>			201
	Color or shade of any component not as specified.			202
	Any thread not trimmed to ¹ / ₁₆ inch and not covered by heat sealed seam tape.			203
	Any neck seal attachment seam not covered with the specified tape.		101	
	Zipper not covered properly or not covered with the specified tape.		102	
	Any damaged tape edges greater than ¹ / ₁₆ -inch from the outside edge.			204
	More than three, two-inch diameter mending patches per coverall.	3		
	Inspection form missing or not completely filled out.		103	
	Marking of inside of suit with utensil other than a wax marking pencil for leakage or discrepancy identification.		104	
	Material and components more than 18 months old.	4		

MIL-DTL-85633D

TABLE VIII. Classification of end item defects - Continued.

EXAMINE	DEFECT	CLASSIFICATION		
		CRITICAL	MAJOR	MINOR
ZIPPERS	Any part of a zipper bent, broken, or otherwise defective.	5		
	Zipper not closing as specified. <u>2/</u>	6		
	Length of zipper not as specified.		105	
	Entry or portal zipper excessively lubricated or not lubricated.			205
COMPONENTS AND ASSEMBLY	Any defective component or defect that will affect the form, fit, and function of the assembly.	7		
	Any component part not as specified, omitted, or operation improperly performed.	8		
	Any component part not cut in accordance with the patterns.		106	
HEAT SEALING	Any seam tape not located as specified		107	
	Any stitching not covered by seam tape.	9		
	Any splice taping not overlapped $\frac{3}{4}$ inch.		108	
SEAMS AND STITCHING	Any seam or attachment of any component twisted, puckered, pleated, or caught in any unrelated operation or stitching that is not properly forced out or contained in a fold more than $\frac{1}{8}$ inch.		109	
	End of stitching not securely backstitched for at least $\frac{1}{2}$ inch when not caught in other seams or stitching.		110	
	Thread breaks, skips, and run-offs not securely overstitched for at least $\frac{1}{2}$ inch.		111	
	Any stitching irregular or unevenly gauged (greater than 50% of the seam length or 4 inches, whichever is less).		112	

MIL-DTL-85633D

TABLE VIII. Classification of end item defects - Continued.

EXAMINE	DEFECT	CLASSIFICATION		
		CRITICAL	MAJOR	MINOR
SEAMS AND STITCHING Continued	Not specified seam or stitch type.		113	
	Loose tension resulting in a loose seam or tight tension resulting in breaking of stitches when normal pull is applied 3/.		114	
	Stitches per inch - one or two stitches more or less than specified (to be scored only when condition exists on 25% of the seam or more).			206
	Stitches per inch more than two stitches more or less than specified (to be scored only when condition exists on 25% of the seam or more).		115	
	Any open seam 4/.	10		
LABEL AND TAG	Label/tag missing or insecurely attached.		116	
	Size/information on label missing, incorrect, or illegible.		117	
	Point size on label incorrect.			207
FINISHED GARMENT	Coverall not properly folded.			208
	Coverall not preserved as specified.			209
POCKET ZIPPER COVERINGS (Type II only)	Edges of zipper coverings overlapping more than $\frac{1}{16}$ inch or gapped more than $\frac{1}{16}$ inch, when zipper is closed.			210
	Beading omitted in zipper covering.		118	
	Beading not sewn taut in zipper covering.			211

MIL-DTL-85633D

TABLE VIII. Classification of end item defects - Continued.

EXAMINE	DEFECT	CLASSIFICATION		
		CRITICAL	MAJOR	MINOR
BARTACK (Type II only)	Any bartack omitted, loose, misplaced, or not serving intended purpose.		119	
	Bartack omitted, loose, misplaced, or not serving intended purpose on multiple pencil compartment pocket: one bartack two or more bartacks		120	212
	Length of any bartack on multiple pencil compartment pocket not as specified.			213
POCKET (Type II only)	Any breast, thigh, or lower leg pocket out of horizontal or vertical alignment: more than $\frac{3}{8}$ inch, but not more than $\frac{1}{2}$ inch more than $\frac{1}{2}$ inch			214
	Any breast, thigh, or lower leg pocket poorly shaped or not uniform in size and shape.			215
	Pencil compartment pocket not on left sleeve.		122	
	Pencil pocket protective flap omitted.		123	
	One pencil compartment omitted.			216
	Omitted, misplaced, incorrect size		124	
	Omitted, does not mate		125	
	POCKET (Type V)	Omitted		126

MIL-DTL-85633D

TABLE VIII. Classification of end item defects - Continued.

EXAMINE	DEFECT	CLASSIFICATION		
		CRITICAL	MAJOR	MINOR
HOOK AND LOOP FASTENER TAPE (Type IV and V)	Omitted, does not align		127	
ZIPPER THONG (Type V)	Omitted		128	
	Dimensions not as specified		129	
END ITEM DIMENSIONS	Any dimension not within specified tolerances of Tables IV, V, or VI, as applicable		130	
	Any construction dimension that affects form, fit, or function		131	
	Any construction dimension that does not affect form, fit, or function			217

1/ Clearly visible shall be interpreted as meaning clearly visible at an examination distance of 3 feet.

2/ The zippers shall be checked for proper function by opening and closing each zipper not less than three times along its full length.

3/ Puckering is evidence of tight tension or gathering of the material. When puckering is evident and is caused by the gathering of the material, the stitching shall be inspected for tight tension and breaking of stitches by exerting normal pull in the lengthwise direction of the stitching, by pulling the material taut to straighten out the seam. Puckering due to the gathering of the material shall be classified and scored as a seaming defect.

4/ A seam shall be considered open whether one side or both sides are open.

4.5.2.2 End item dimensional examination. The end item shall be examined for conformance to the dimensions specified in 3.13 and tables IV through VI, as applicable.

4.5.3 Coverall leakage. Using the apparatus specified in MIL-W-85635 and the procedures specified herein, each of the assembled coveralls shall be tested for conformance to the requirements of 3.14. The water leakage test shall be accomplished in one complete cycle from start to finish without interruption.

a. Fill the reservoir with approximately 30 gallons of clean, fresh water and add 60 milliliters (ml) (1/4 cup) of chlorine bleach. The bleach shall be added at the initial filling of the reservoir and at each subsequent refilling. Do not add more than 60 ml (1/4 cup) of bleach for

MIL-DTL-85633D

each reservoir full of water. The reservoir shall be drained and the water replaced at least monthly or more often if the water becomes dirty, slimy, dank, or odoriferous.

b. Secure the water leakage inspection apparatus in the horizontal position with the platform open.

c. The garment to be inspected shall be turned inside out with the entrance and relief zippers, as applicable, fully closed. Lay the coverall on the bottom half of the platform, positioning the neck opening to the left and the entrance zipper facing up. Care shall be taken while inserting the coverall in the test apparatus to ensure that the garment is not pinched.

d. Close off the left wrist, neck, and each leg opening with a clamp. The openings shall be folded prior to clamping to avoid leakage at the openings.

e. Extend the right sleeve of the coverall through the opening provided in the side of the inspection apparatus. OPTIONAL STEP: Route 2-inch hook and pile tape loosely around each thigh, just below the crotch, and just above the leg opening, to help separate the legs and facilitate visual inspection. Close the top gate and secure all four latches.

f. Route water hose over the platform hook and place water hose into right sleeve opening. Grasp water hose and wrist seal/sleeve firmly making sure to leave an opening in the sleeve to allow air inside the coverall to escape while filling the coverall with water. While holding hose and sleeve, turn pump on by depressing footswitch and fill coverall until water reaches the shoulder of the coverall sleeve. If the water does not flow from the filling hose within 5 seconds from the time the switch is turned to the "on" position, prime the pump by clicking the switch "off" and "on" several times.

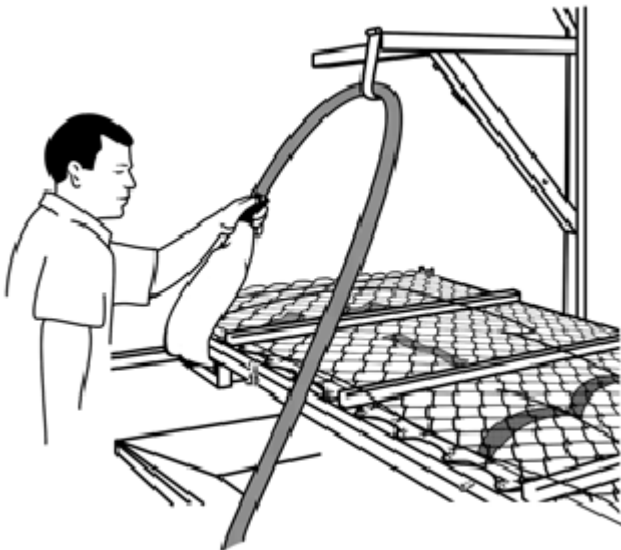

g. Turn the pump off and rotate the inspection apparatus 90° to a vertical position and secure the platform. If necessary, turn the pump on again and refill the coverall to within 6 inches of the right sleeve wrist opening.

MIL-DTL-85633D

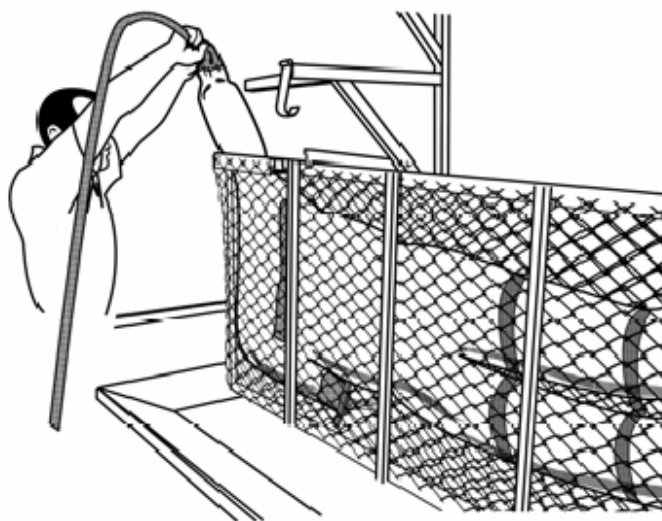

h. Turn the pump off, remove hose, and clamp off right sleeve wrist opening in a similar manner as described in 4.5.3d.

i. Rotate the inspection platform back to the horizontal (front facing upwards) and lock in place. The coverall should be firm to the touch, like a well-inflated helium balloon, not gelatinous or wobbly like an under inflated helium balloon.

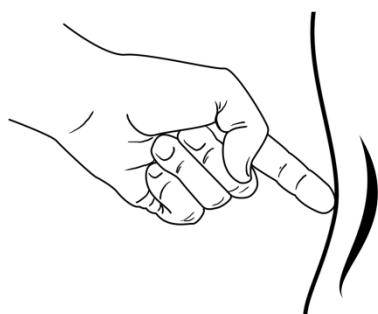

Correct

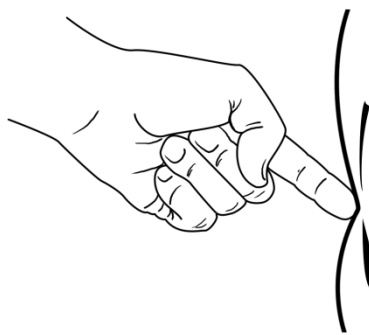

Under-inflated

j. While the inspection platform is in the horizontal position (front of coverall facing upwards), inspect back of the coverall (underside) for leaks, including areas under the thigh and ankle securing fastener tapes by temporarily loosening the hook and pile closures. If water appears on the coverall surface, blot area dry with an absorbent material, such as a paper towel, and observe whether the water reappears. If water does not reappear within 10 seconds, it will not be considered a leak.

MIL-DTL-85633D

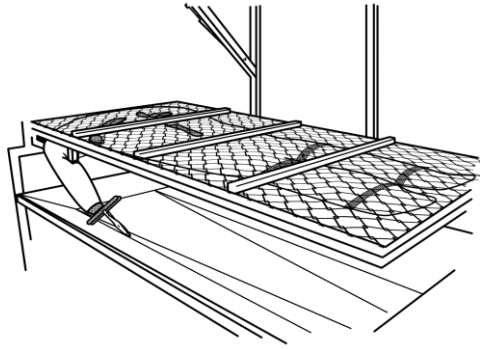

k. If the water reappears, mark the suspect area with a wax marking pencil for repair. Do not use any other kind of pencil for marking. If minor leakage is attributable to the stitched seams exposed on the outside perimeter of the zipper area, it is acceptable to apply a thin layer of a neoprene base adhesive to the inside of the rubber covered zipper tape.

l. Rotate the platform 180° to the horizontal position again so that the front of the suit is at the bottom closest to the splash pan. Inspect the front of the coverall and slide fastener box stitching near seal block for any water leakage. If water appears and drips within 10 seconds, mark suspect area for patching using only a wax marking pencil.

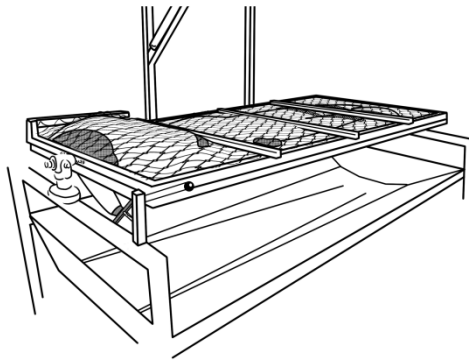

m. After marking all suspect areas for repair, rotate platform back to original horizontal position and lock in place. Remove sleeve clamp from right wrist and slowly drain water from the coverall.

n. Open platform, remove clamps, hook and pile tape (if used), and drain any remaining water.

o. Turn coverall right side out.

p. Fully dry coverall. When using a dryer, set dryer at lowest temperature setting and dry coverall for a maximum of 20 minutes. When air drying, hang the coverall on a wooden hanger and allow to air dry. After hanging for a maximum of 4 hours, check coverall for dryness.

q. Ensure that all areas requiring patching are clearly marked.

MIL-DTL-85633D

r. Determine reparability of a coverall by patching (see 3.12.1).

5. PACKAGING

5.1 Packaging. For acquisition purposes, the packaging requirements shall be as specified in the contract or order (see 6.2). When packaging of materiel is to be performed by DoD or in-house contractor personnel, these personnel need to contact the responsible packaging activity to ascertain packaging requirements. Packaging requirements are maintained by the Inventory Control Point's packaging activity within the Military Service or Defense Agency, or within the military service's system commands. Packaging data retrieval is available from the managing Military Department's or Defense Agency's automated packaging files, CD-ROM products, or by contacting the responsible packaging activity.

6. NOTES

(This section contains information of a general or explanatory nature that may be helpful, but is not mandatory.)

6.1 Intended use. The coveralls are military unique because they are used for continuous wear by military aircrew members on flights over water, in the event of immersion into water. The coveralls are intended to protect the wearer from exposure to cold water, wind, spray, and rain, and to protect against hypothermia. The coveralls are intended to be used in conjunction with waterproof wrist seals and socks fitted on an individual basis as applicable (see 3.6.1, 3.6.2, and 3.6.3).

6.2 Acquisition requirements. Acquisition documents should specify the following:

- a. Title, number, and date of this specification, including any amendments.
- b. Type, quantity desired (see 1.2.1).
- c. National stock number (see 3.5.1).
- d. Applicable Government patterns and drawings, including revisions.
- e. Whether first article and conformance inspection is required (see 4.3 and 4.4).
- f. Number of first article inspection samples (see 4.3.1).
- g. Name and address of the first article inspection facility; and the name and address of the Government activity responsible for conducting the first article inspection program.
- h. Packaging required (see 5.1).

MIL-DTL-85633D

6.3 Qualification. With respect to products requiring qualification, awards will be made only for products which are, at the time of award of contract, qualified for inclusion in Qualified Products List, QPL-85633, whether or not such products have actually been so listed by that date. The attention of the contractors is called to these requirements, and manufacturers are urged to arrange to have the products that they propose to offer to the Federal Government tested for qualification in order that they may be eligible to be awarded contracts or orders for the products covered by this specification. Information pertaining to qualification of products may be obtained from: Commander, Naval Air Systems Command, Aviation Life Support Systems, Code 4.6.2.2, Building 2187, Suite 1240, 48110 Shaw Road, Unit 5, Patuxent River, MD 20670-1906. An online listing of products qualified to this specification may be found in the Qualified Products Database (QPD) at <https://assist.dla.mil>.

6.3.1 Qualification samples. The samples should be forwarded to the test facility set forth in the letter of authorization to submit samples (see 6.3). The samples should be plainly identified by securely attached durable tags marked with the following information:

Samples for qualification inspection
Coveralls, Flyers, Anti-Exposure (Type as applicable)
Manufacturer's designation or number
Name of manufacturer
Submitted by (name) (date) for qualification inspection in accordance with the requirements of this document under authorization (reference authorizing letter and number) (see 6.3).

6.3.2 Retention. The retention of qualification listing should consist of periodic verification to determine compliance of the qualified coveralls with the requirements of this document. Periodic verification should be by certification unless otherwise specified by the activity responsible for the Qualified Products List and should be at intervals of not more than two years.

6.4 First article. When first article inspection (see 3.2) is required, the contracting officer should provide specific guidance to offerors whether the item(s) should be a first article sample, a first production item, or a standard production item from the contractor's current inventory, and the number of items to be tested as specified in 4.3.1. Invitations for bids should provide that the Government reserves the right to waive the requirement for samples for first article inspection to those bidders offering a product which has been previously acquired or tested by the Government, and that bidders offering such products, who wish to rely on such production or test, must furnish evidence with the bid that prior Government approval is presently appropriate for the pending contract. Bidders should not submit alternate bids unless specifically requested to do so in the solicitation.

6.5 Patterns. To request patterns, contact the procuring activity issuing the invitation for bid.

MIL-DTL-85633D

6.5.1 Pattern numbers. The patterns listed in 3.8.1, table II have been identified with a NAVAIR drawing number for the purpose of configuration control and tracking of pattern changes. These numbers range from 1370AS481 - 1370AS493 for the type II coverall. These numbers do not have any effect on manufacturing.

6.6 Sources of supply.

6.6.1 Entry and portal zippers. Omni-environmental barrier zippers meeting the requirements of 3.4.5.1 are available from the following source:

YKK (USA) Inc., c/o Diversified Marketing Group, 109 Forrest Avenue, Narberth, PA 19072, Vendor part number: TZ NC-81

6.6.2 Pocket and overvest zippers. The following part numbers are applicable (see 3.4.5.3):

00I-07-IEF-C-05-N-26/4 for the pencil pocket zipper

00I-04-IEF-C-05-N-36/4 for the calf pocket

00I-04-IEF-C-05-N-lengths as specified for the overvest zippers

6.7 Shelf-life. This specification covers items where shelf-life is a consideration. Specific shelf-life requirements should be specified in the contract or purchase order. The shelf-life codes are contained in the Federal Logistics Information System Total Item Record. Additive information for shelf-life management may be obtained from *DoD 4140.27-M Shelf-life Management Manual*, or the designated shelf-life Points of Contact (POC). The POC should be contacted in the following order: (1) the Inventory Control Points (ICPs), and (2) the DoD Service and Agency administrators for the DoD Shelf-Life Program. Appropriate POCs for the DoD Shelf-Life Program can be contacted through the DoD Shelf-Life Management website: <http://www.shelflife.hq.dla.mil/>.

6.8 Subject term (key word) listing.

Dry-Suit

Flight Clothing

Neck Seal

Sealing Machine, Heat

Shelf-life

Water Immersion

Wrist Seal

6.9 Changes from previous issue. Marginal notations are not used in this revision to identify changes with respect to the previous issue due to the extent of the changes.

MIL-DTL-85633D

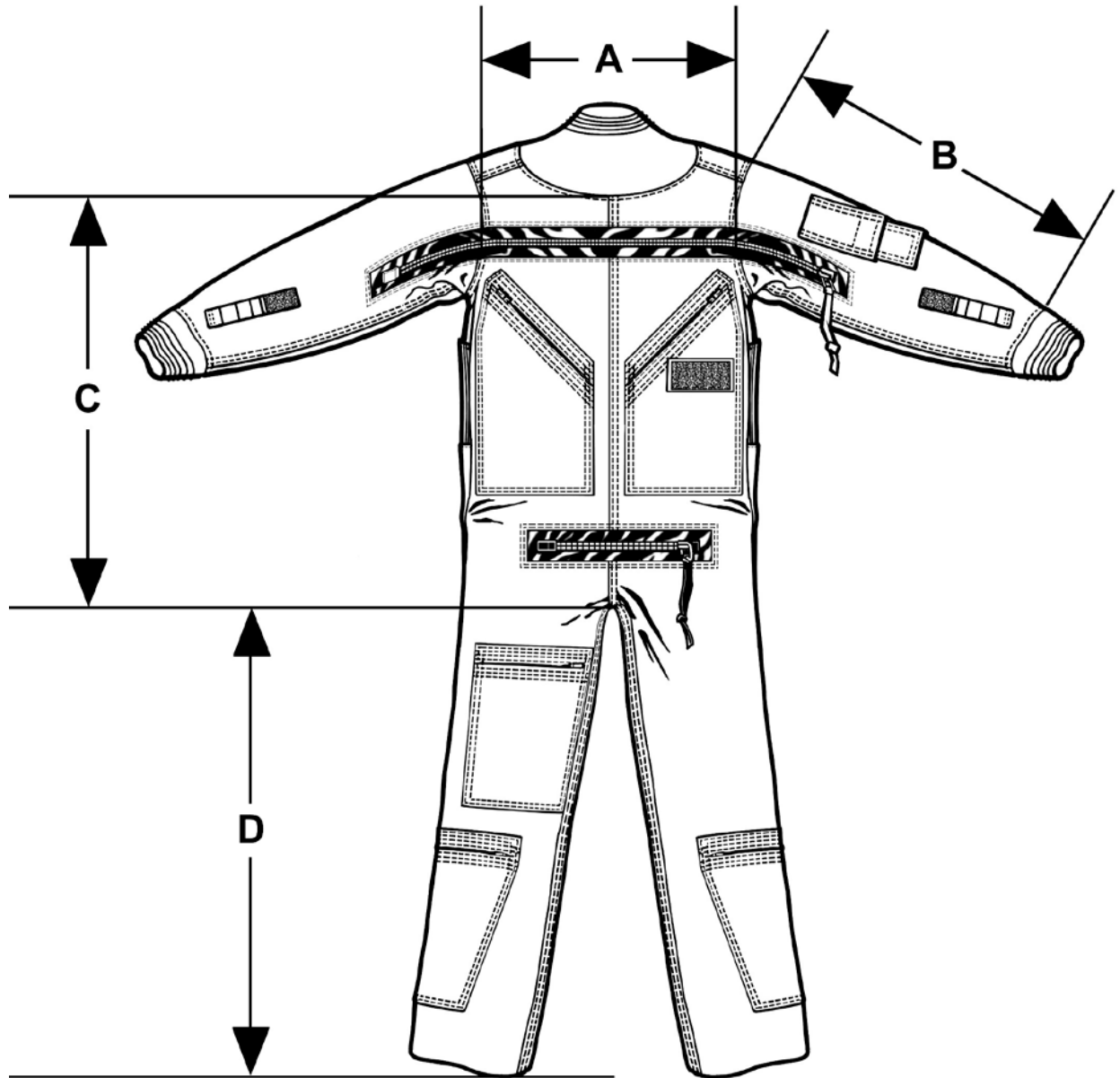

FIGURE 1. CWU-74/P.

MIL-DTL-85633D

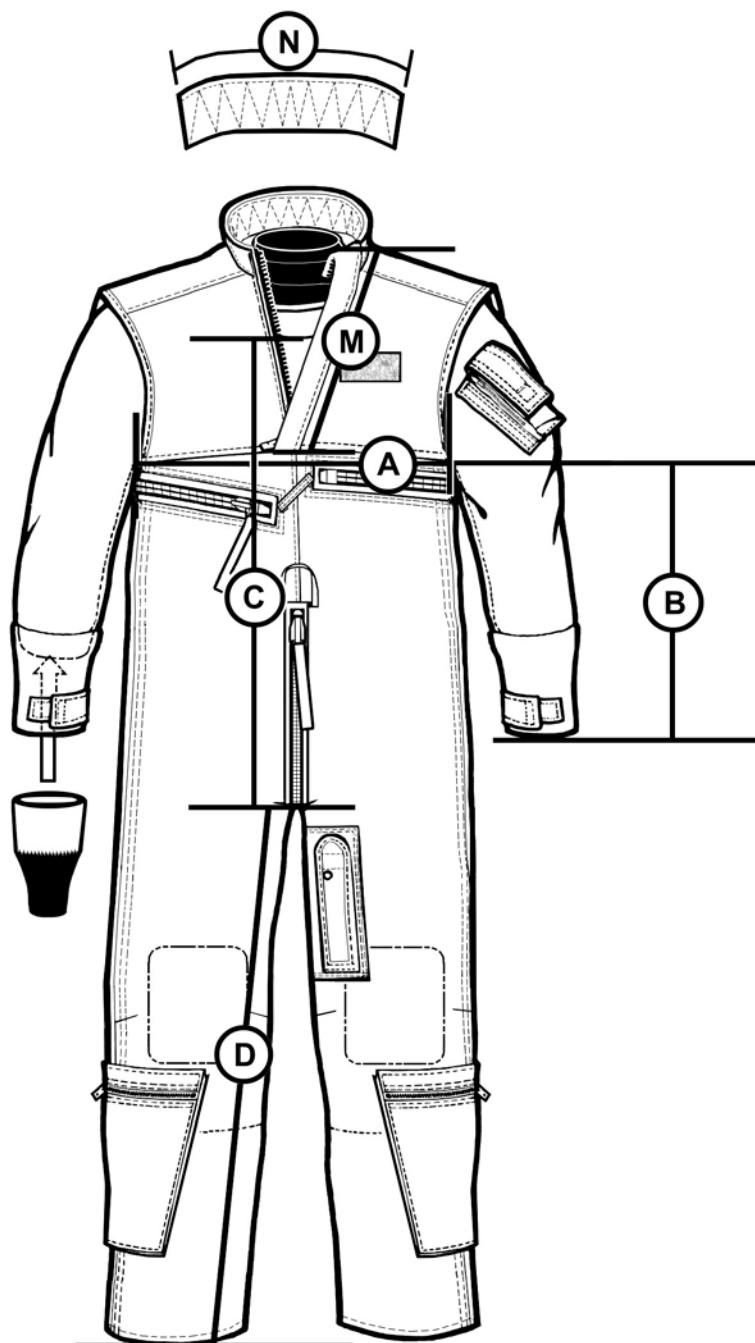

FIGURE 2. CWU-86/P front.

MIL-DTL-85633D

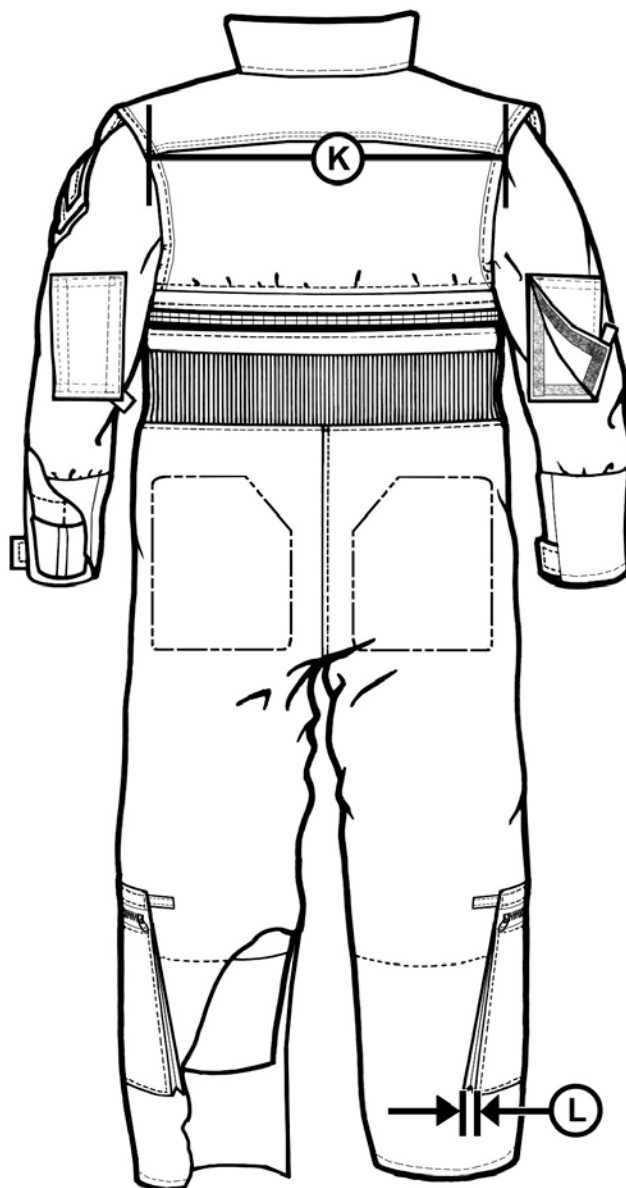

FIGURE 3. CWU-86/P back.

MIL-DTL-85633D

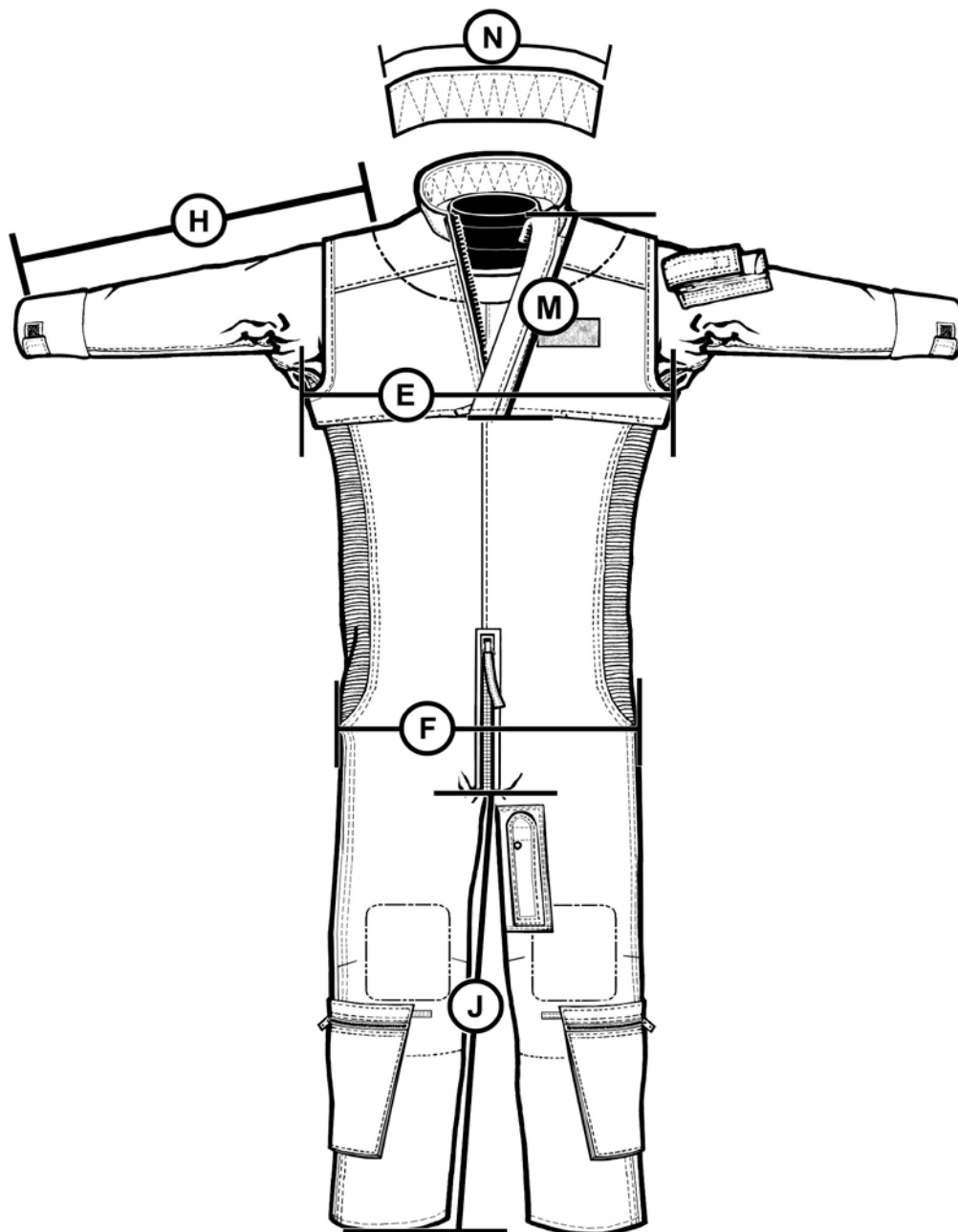

FIGURE 4. CWU-87/P front.

MIL-DTL-85633D

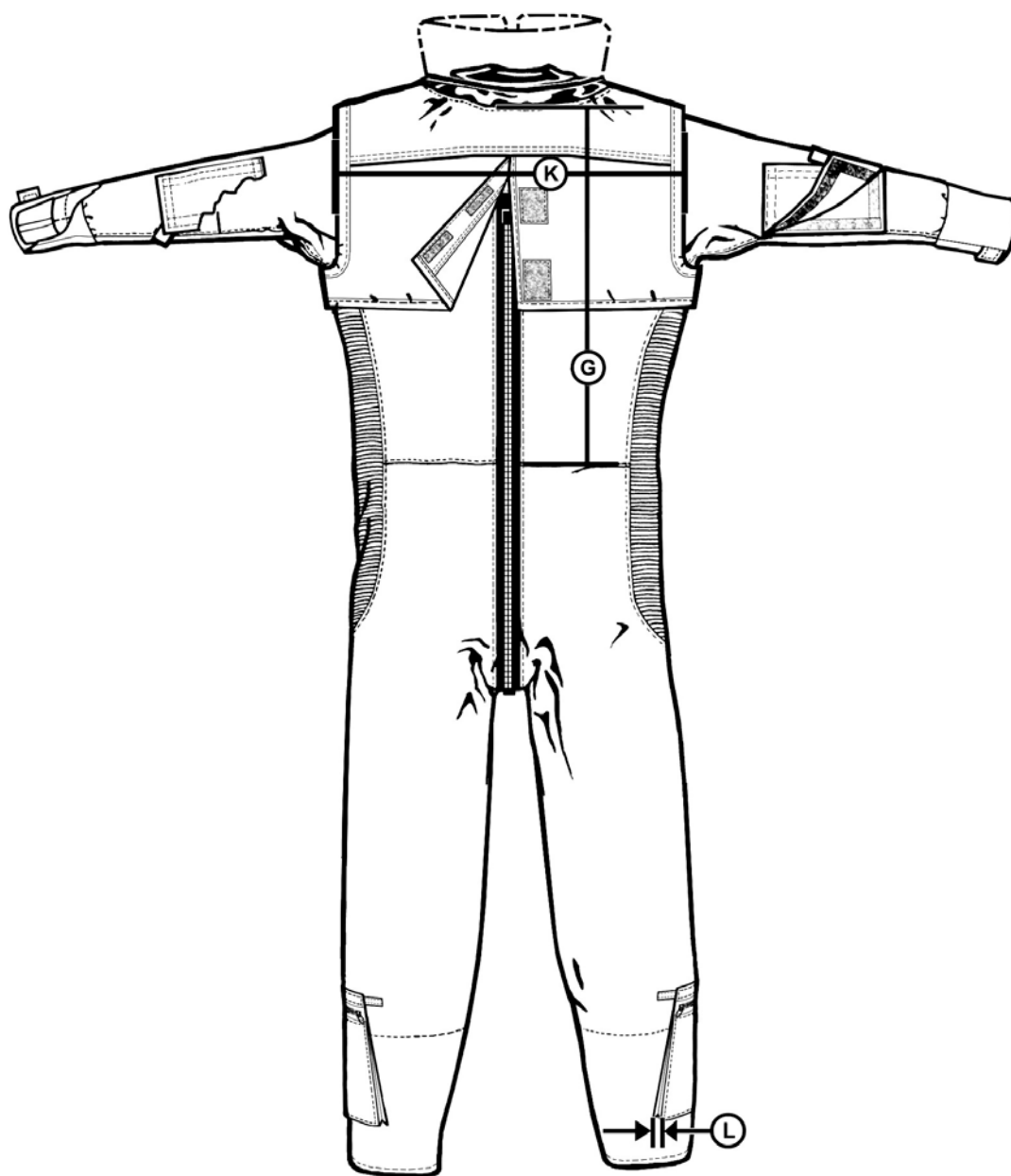

FIGURE 5. CWU-87/P back.

MIL-DTL-85633D

Name of Contractor: _____ Date: _____

Contract Number: _____ Coverall Serial Number: _____

No Leaks _____

Leaks (number) _____ Repaired (Date) _____

Passed: Yes _____ No _____ Inspected by: _____

Mark repair location on diagram below (suit is shown inside out):

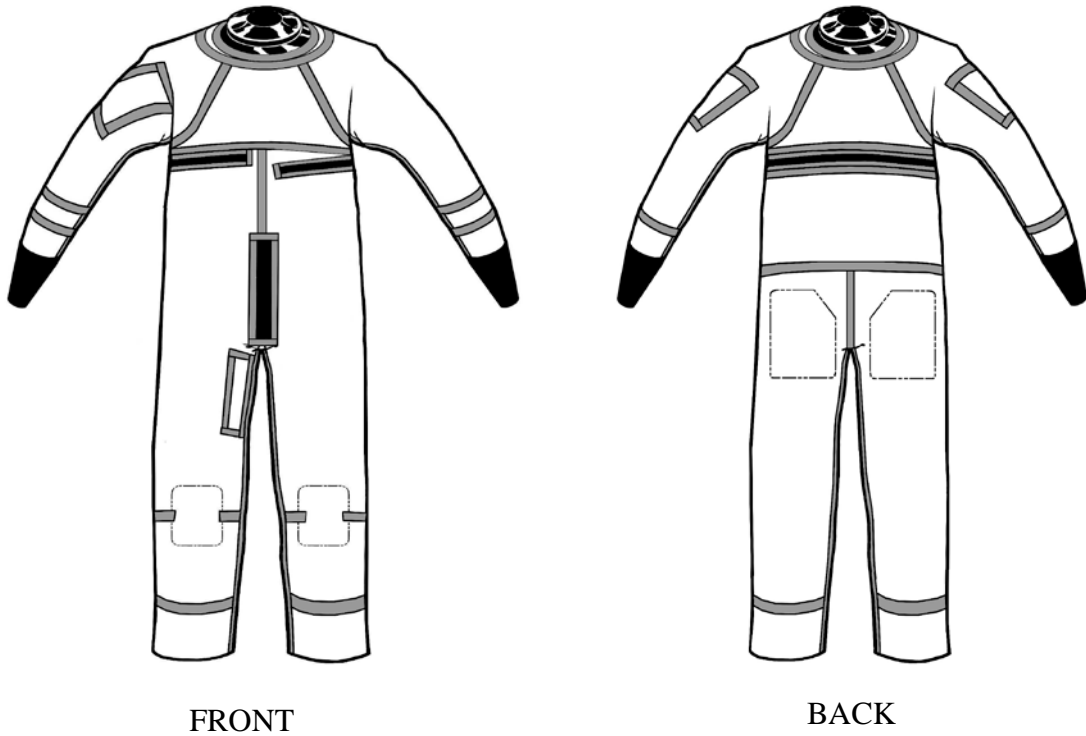

FIGURE 6. CWU-86/P Ruggedized anti-exposure coverall, patch location and test information.

MIL-DTL-85633D

Name of Contractor: _____ Date: _____

Contract Number: _____ Coverall Serial Number: _____

No Leaks: _____

Leaks (number): _____ Repaired (Date): _____

Passed: Yes _____ No _____ Inspected by: _____

Mark repair location on diagram below (suit is shown inside out):

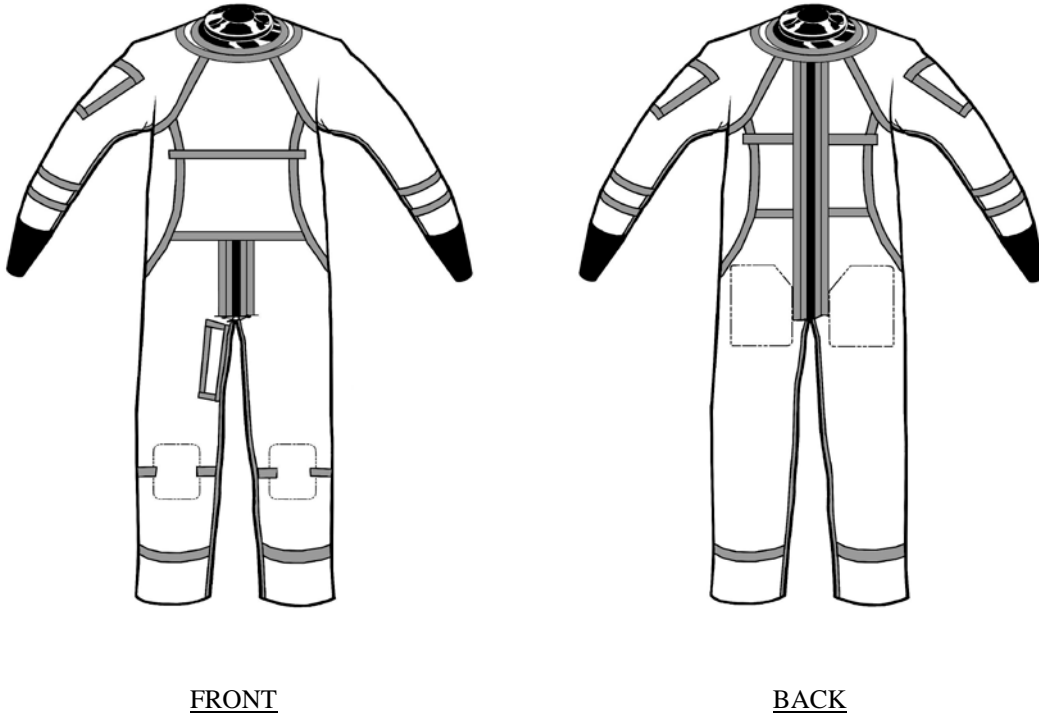

FIGURE 7. CWU-87/P Ruggedized anti-exposure coverall, patch location and test information.

MIL-DTL-85633D

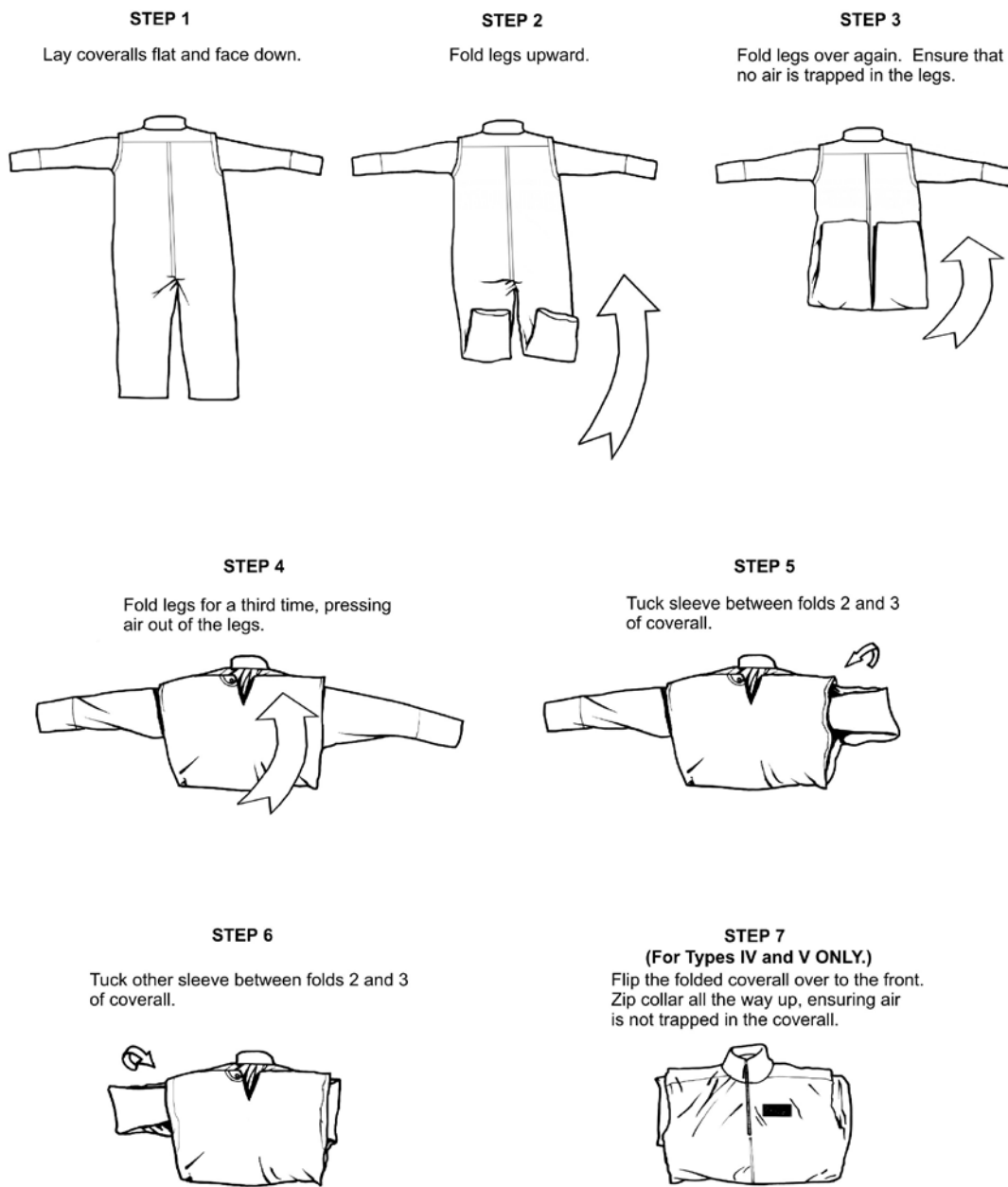

FIGURE 8. Coverall folding procedures.

MIL-DTL-85633D

CONCLUDING MATERIAL

Custodians:

Army - AV
Navy - AS
Air Force - 11
DLA-CT

Preparing activity:

Navy - AS
(Project 8475-2014-002)

Review activity:

Navy-NU

NOTE: The activities listed above were interested in this document as of the date of this document. Since organizations and responsibilities can change, you should verify the currency of the information above using ASSIST Online database at <https://assist.dla.mil>.