

INCH-POUND

MIL-DTL-83798D
w/AMENDMENT 3
23 May 2012
SUPERSEDING
w/AMENDMENT 2
14 February 2012

DETAIL SPECIFICATION

FITTING, RUBBER HOSE, LIGHTWEIGHT, MEDIUM PRESSURE,
GENERAL SPECIFICATION FOR

This specification is approved for use by all Departments and
Agencies of the Department of Defense.

1. SCOPE

1.1 Scope. This specification covers the requirements for fitting, rubber hose, lightweight, medium pressure. These are field attachable fluid fittings for use with a lightweight, medium pressure, rubber hose with operating limits of -65°F to 250°F and 200 to 1000 psig.

1.2 Part or Identifying Number (PIN). The PIN consists of the letters M, the basic specification number, specification sheet number, a dash number for fitting size, the letter L for lockwire or blank for no lockwire, and a letter for material and finish code.

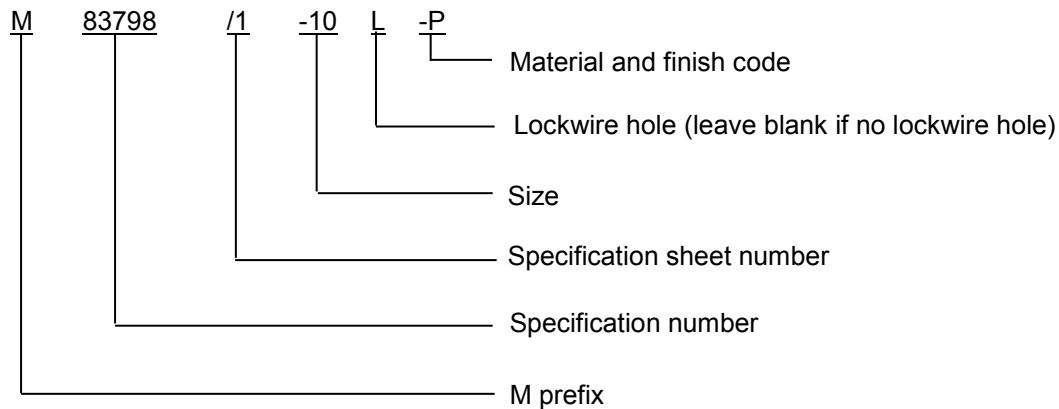

Comments, suggestions, or questions on this document should be addressed to: DLA Land and Maritime Attn: VAI, P.O. Box 3990, Columbus, OH 43218-3990, or emailed to FluidFlow@dla.mil. Since contact information can change, you may want to verify the currency of this address information using the ASSIST Online database at <https://assist.daps.dla.mil>.

MIL-DTL-83798D
w/AMENDMENT 3

2. APPLICABLE DOCUMENTS

2.1 General. The documents listed in this section are specified in sections 3, 4 or 5 of this specification. This section does not include documents cited in other sections of this specification or recommended for additional information or as examples. While every effort has been made to ensure the completeness of this list, document users are cautioned that they must meet all specified requirements documents cited in sections 3, 4 or 5 of this specification, whether or not they are listed.

2.2 Government documents.

2.2.1 Specifications, standards, and handbooks. The following specifications, standards, and handbooks form a part of this document to the extent specified herein. Unless otherwise specified, the issues of these documents are those cited in the solicitation or contract.

DEPARTMENT OF DEFENSE SPECIFICATIONS

MIL-A-8625	-	Anodic Coatings for Aluminum and Aluminum Alloys
MIL-DTL-16232	-	Phosphate Coating, Heavy, Manganese or Zinc Base
MIL-DTL-81706	-	Chemical Conversion Materials For Coating Aluminum and Aluminum Alloys
MIL-DTL-83796	-	Hose Assembly, Rubber, Lightweight, Medium Pressure, General Specification for
MIL-DTL-83796/1	-	Hose Assembly, Rubber, Lightweight, Medium Pressure, Field Attachable End Fittings, Flare to Flare
MIL-DTL-83796/2	-	Hose Assembly, Rubber, Lightweight, Medium Pressure, Field Attachable End Fittings, Flare to Flare, with Lockwire Hole
MIL-DTL-83796/3	-	Hose Assembly, Rubber, Lightweight, Medium Pressure, Field Attachable End Fittings, Flareless to Flareless
MIL-DTL-83796/4	-	Hose Assembly, Rubber, Lightweight, Medium Pressure, Field Attachable End Fittings, Flareless to Flareless, with Lockwire Hole
MIL-DTL-83796/5	-	Hose Assembly, Rubber, Lightweight, Medium Pressure, Field Attachable End Fittings, Flare to Flange
MIL-DTL-83796/6	-	Hose Assembly, Rubber, Lightweight, Medium Pressure, Field Attachable End Fittings, Flare to Flange, with Lockwire Hole
MIL-DTL-83796/7	-	Hose Assembly, Rubber, Lightweight, Medium Pressure, Field Attachable End Fittings, Flareless to Flange
MIL-DTL-83796/8	-	Hose Assembly, Rubber, Lightweight, Medium Pressure, Field Attachable End Fittings, Flareless to Flange, with Lockwire Hole
MIL-DTL-83796/9	-	Hose Assembly, Rubber, Lightweight, Medium Pressure, Field Attachable End Fittings, Flange to Flange
MIL-DTL-83796/10	-	Hose Assembly, Rubber, Light Weight, Internal Support Coil, Medium Pressure, Field Attachable End Fittings, Flare to Flare
MIL-DTL-83796/11	-	Hose Assembly, Rubber, Lightweight, Medium Pressure, Internal Support Coil, Field Attachable End Fittings, Flare to Flare, with Lockwire Hole
MIL-DTL-83796/12	-	Hose Assembly, Rubber, Lightweight, Medium Pressure, Internal Support Coil, Field Attachable End Fittings, Flareless to Flareless
MIL-DTL-83796/13	-	Hose assembly, Rubber, Lightweight, Medium Pressure, Internal Support Coil, Field Attachable End Fittings, Flareless to Flareless, With Lockwire Hole
MIL-DTL-83796/14	-	Hose Assembly, Rubber, Lightweight, Medium Pressure, Internal Support Coil, Field Attachable End Fittings, Flare to Flange

MIL-DTL-83798D
w/AMENDMENT 3

- | | | |
|------------------|---|--|
| MIL-DTL-83796/15 | - | Hose Assembly, Rubber, Lightweight, Medium Pressure, Internal Support Coil, Field Attachable End Fittings, Flare to Flange, With Lockwire Hole |
| MIL-DTL-83796/16 | - | Hose Assembly, Rubber, Lightweight, Medium Pressure, Internal Support Coil, Field Attachable End Fittings, Flareless to Flange |
| MIL-DTL-83796/17 | - | Hose Assembly, Rubber, Lightweight, Medium Pressure, Internal Support Coil, Field Attachable End Fittings, Flareless to Flange, With Lockwire Hole |
| MIL-DTL-83796/18 | - | Hose Assembly, Rubber, Lightweight, Medium Pressure, Internal Support Coil, Field Attachable End Fittings, Flange to Flange |
| MIL-DTL-83797 | - | Hose, Rubber, Lightweight, Medium Pressure, General Specification For |
| MIL-PRF-5606 | - | Hydraulic Fluid, Petroleum Base; Aircraft, Missile, and Ordnance |
| MIL-PRF-7808 | - | Lubricating Oil, Aircraft Turbine Engine, Synthetic Base |
| MIL-PRF-83282 | - | Hydraulic Fluid, Fire Resistant, Synthetic Hydrocarbon Base, Metric, NATO Code Number H-537 |
| MIL-PRF-87257 | - | Hydraulic Fluid, Fire Resistant; Low Temperature, Synthetic Hydrocarbon Base, Aircraft and Missile |

(See supplement 1 for list of specification sheets.)

DEPARTMENT OF DEFENSE STANDARDS

- | | | |
|-------------|---|--|
| MIL-STD-130 | - | Identification Marking of U.S. Military Property |
| MIL-STD-889 | - | Dissimilar Metals |
| MS20756 | - | Flange, Swivel, Retaining |
| MS33786 | - | Fitting Installation, Flared Tube and Hose, Swivel |

(Copies of these documents are available online at <https://assist.daps.dla.mil/quicksearch/> or from the Standardization Document Order Desk, 700 Robbins Avenue, Building 4D, Philadelphia, PA 19111-5094.)

2.3 Non-Government publications. The following documents form a part of this document to the extent specified herein. Unless otherwise specified, the issues of these documents are those cited in the solicitation or contract.

ASME INTERNATIONAL

- | | | |
|------------|---|---|
| ASME B46.1 | - | Surface Texture (Surface Roughness, Waviness and Lay) |
|------------|---|---|

(Copies of these documents are available online at <http://www.asme.org> or from the ASME International, Three Park Avenue, New York, NY 10016-5990.)

ASTM INTERNATIONAL

- | | | |
|-----------------|---|---|
| ASTM A276 | - | Standard Specification for Stainless Steel Bars and Shapes |
| ASTM A493 | - | Standard Specification for Stainless Steel Wire and Wire Rods for Cold Heading and Cold Forging |
| ASTM A564/A564M | - | Standard Specification for Hot-Rolled and Cold-Finished Age-Hardening Stainless Steel Bars and Shapes |
| ASTM A580/A580M | - | Standard Specification for Stainless Steel Wire |
| ASTM B210 | - | Standard Specification for Aluminum and Aluminum-Alloy Drawn Seamless Tubes |

MIL-DTL-83798D
w/AMENDMENT 3

- ASTM B221 - Standard Specification for Aluminum and Aluminum-Alloy Extruded Bars, Rods, Wire, Profiles, and Tubes
- ASTM B487 - Standard Test Method for Measurement of Metal and Oxide Coating Thickness by Microscopical Examination of Cross Section
- ASTM B499 - Standard Test Method for Measurement of Coating Thicknesses by the Magnetic Method: Nonmagnetic Coatings on Magnetic Basis Metals
- ASTM B567 - Standard Test Method for Measurement of Coating Thickness by the Beta Backscatter Method
- ASTM B568 - Standard Test Method for Measurement of Coating Thickness by X-Ray Spectrometry
- ASTM B633 - Standard Specification for Electrodeposited Coatings of Zinc on Iron and Steel
- ASTM B695 - Standard Specification for Coatings of Zinc Mechanically Deposited on Iron and Steel
- ASTM B748 - Standard Test Method for Measurement of Thickness of Metallic Coatings by Measurement of Cross Section with a Scanning Electron Microscope
- ASTM D380 - Standard Test Methods for Rubber Hose

(Copies of these documents are available online at <http://www.astm.org> or from ASTM International, P.O. Box C700, 100 Barr Harbor Drive, West Conshohocken, PA 19428-2959.)

NCSL INTERNATIONAL

- NCSL Z540.3 - Requirements for the Calibration of Measuring and Test Equipment

(Copies of these documents are available online at <http://www.ncsli.org> or from NCSL International 2995 Wilderness Place, Suite 107 Boulder, Colorado 80301-5404.)

INTERNATIONAL ORGANIZATION FOR STANDARDIZATION (ISO)

- ISO 17025 - General requirements for the competence of testing and calibration laboratories

(Copies of these documents are available online at www.ansi.org or from the ANSI Customer Service Department, 25 W. 43rd Street, 4th Floor, New York, NY 10036.)

SAE INTERNATIONAL

- SAE-AMS-A-22771 - Aluminum Alloy Forgings, Heat Treated
- SAE-AMS-QQ-A-200/8 - Aluminum Alloy 6061, Bar, Rod, Shapes, Tube, and Wire, Extruded - UNS A96061
- SAE-AMS-QQ-A-225/6 - Aluminum Alloy, 2024, Bar, Rod, and Wire; Rolled, Drawn, or Cold Finished
- SAE-AMS-QQ-A-225/9 - Aluminum Alloy 7075, Bar, Rod, Wire, and Special Shapes; Rolled, Drawn, or Cold Finished
- SAE-AMS-QQ-A-367 - Aluminum Alloy Forgings
- SAE-AMS-QQ-P-416 - Plating, Cadmium (Electrodeposited)
- SAE-AMS-WW-T-700/6 - Tube, Aluminum Alloy, Drawn, Seamless, 6061
- SAE-AMS2417 - Plating, Zinc-Nickel Alloy
- SAE-AMS2451/5 - Plating, Brush, Chromium Hard Deposit, Trivalent
- SAE-AMS2451/9 - Plating, Brush, Zinc-Nickel Low Hydrogen Embrittlement

MIL-DTL-83798D
w/AMENDMENT 3

SAE-AMS2486	- Conversion Coating of Titanium Alloys Fluoride-Phosphate Type
SAE-AMS2488	- Anodic Treatment - Titanium and Titanium Alloys Solution pH 13 or Higher
SAE-AMS2700	- Passivation of Corrosion Resistant Steels
SAE-AMS2770	- Heat Treatment of Wrought Aluminum Alloy Parts
SAE-AMS4080	- Aluminum Alloy, Drawn Seamless Tubing 1.0Mg - 0.60Si - 0.28Cu - 0.20Cr (6061-O) Annealed - UNS A96061
SAE-AMS4082	- Aluminum Alloy, Seamless Drawn Tubing 1.0Mg - 0.60Si - 0.28Cu - 0.20Cr (6061-T6) Solution and Precipitation Heat Treated - UNS A96061
SAE-AMS4117	- Aluminum Alloy, Rolled or Cold Finished Bars, Rods, and Wire and Flash Welded Rings 1.0Mg - 0.60Si - 0.28Cu - 0.20Cr (6061; -T6, -T651) Solution and Precipitation Heat Treated - UNS A96061
SAE-AMS4120	- Aluminum Alloy, Rolled or Cold Finished Bars, Rods, and Wire 4.4Cu - 1.5Mg - 0.60Mn (2024) Solution Heat Treated and Naturally Aged (T4) Solution Heat Treated, Cold Worked, and Naturally Aged (T351) - UNS A92024
SAE-AMS4124	- Aluminum Alloy, Rolled or Cold Finished Bars, Rods, and Wire 5.6Zn - 2.5Mg - 1.6Cu - 0.23Cr (7075-T7351) Solution Heat Treated, Stress Relieved by Stretching, and Overaged
SAE-AMS4141	- Aluminum Alloy Die Forgings 5.6Zn - 2.5Mg - 1.6Cu - 0.23Cr (7075-T73) Solution and Precipitation Heat Treated
SAE-AMS4133	- Aluminum Alloy Forgings and Rolled Rings 4.4Cu - 0.85Si - 0.80Mn - 0.50Mg (2014-T6) Solution and Precipitation Heat Treated - UNS A92014
SAE-AMS4339	- Aluminum Alloy, Rolled or Cold Finished Bars and Rods 4.4Cu - 1.5Mg - 0.60Mn (2024-T851) Solution Heat Treated, Cold Worked, and Artificially Aged - UNS A92024
SAE-AMS4928	- Titanium Alloy Bars, Wire, Forgings, Rings, and Drawn Shapes 6Al - 4V Annealed
SAE-AMS4946	- Titanium Alloy Tubing, Seamless, Hydraulic 3Al - 2.5V, Texture Controlled Cold Worked, Stress Relieved - UNS R56320
SAE-AMS5050	- Steel Tubing, Seamless 0.15 Carbon, Maximum Annealed - UNS G10100
SAE-AMS5639	- Steel, Corrosion-Resistant, Bars, Wire, Forgings, Tubing, and Rings 19Cr - 10Ni Solution Heat Treated
SAE-AMS5643	- Steel, Corrosion-Resistant, Bars, Wire, Forgings, Tubing, and Rings 16Cr - 4.0Ni - 0.30Cb - 4.0Cu Solution Heat Treated, Precipitation Hardenable
SAE-AMS5645	- Steel, Corrosion and Heat Resistant, Bars, Wire, Forgings, Tubing, and Rings 18Cr - 10Ni - 0.40Ti (SAE 30321) Solution Heat Treated
SAE-AMS5647	- Steel, Corrosion-Resistant, Bars, Wire, Forgings, Tubing, And Rings 19Cr - 9.5Ni Solution Heat Treated
SAE-AMS5743	- Steel, Corrosion and Heat-Resistant, Bars and Forgings 15.5Cr - 4.5Ni - 2.9Mo - 0.10N Solution Heat Treated, Sub-Zero Cooled, Equalized, and Over-Tempered
SAE-AMS6370	- Steel, Bars, Forgings, and Rings 0.95Cr - 0.20Mo (0.28 - 0.33C) (SAE 4130)
SAE-AMS6382	- Steel, Bars, Forgings, and Rings 0.95Cr - 0.20Mo (0.38 - 0.43C) (SAE 4140) Annealed
SAE-ARP908	- Torque Requirements Installation and Qualification Test, Hose and Tube Fittings
SAE-AS4395	- Fitting End-Flared Tube Connection, Design Standard

MIL-DTL-83798D
w/AMENDMENT 3

SAE-AS4841	-	Fittings, 37 Degree Flared, Fluid Connection
SAE-AS5685	-	Steel, Corrosion Resistant, Safety Wire, 18Cr - 11.5Ni (UNS S30500) Solution Heat Treated, Cold Finished
SAE-AS8879	-	Screw Threads - UNJ Profile, Inch
SAE-AS33514	-	Fitting End, Standard Dimensions for Flareless Tube Connection and Gasket Seal

(Available from SAE International, 400 Commonwealth Drive, Warrendale, PA 15096-0001, Tel: 877-606-7323 (inside USA and Canada) or 724-776-4970 of these documents (outside USA), www.sae.org.)

2.4 Order of precedence. Unless otherwise noted herein or in the contract, in the event of a conflict between the text of this document and the references cited herein, (except for related specification sheets), the text of this document takes precedence. Nothing in this document, however, supersedes applicable laws and regulations unless a specific exemption has been obtained.

3. REQUIREMENTS

3.1 Specification sheets. The individual item requirements shall be as specified herein and in accordance with the applicable specification sheet. In the event of any conflict between the requirements of this specification and the specification sheet, the latter shall govern.

3.2 Qualification. Adapters or components furnished under this specification shall be products that are authorized by the qualifying activity for listing on the applicable qualified products list before contract award (see 4.5 and 6.3).

3.3 Materials. Materials shall be as specified herein and shall conform to all applicable specification sheets. When a definite material is not specified, a material shall be used which will enable the hose or hose assembly to meet the requirements of this specification. Acceptance or approval of any constituent material shall not be construed as a guarantee of acceptance of the finished product.

3.3.1 Recycled, recovered, or environmentally preferable materials. Recycled, recovered, or environmentally preferable materials should be used to the maximum extent possible, provided that the material meets or exceeds the operational and maintenance requirements, and promotes economically advantageous life cycle cost.

3.3.2 Dissimilar metals. When dissimilar metals are used in intimate contact with each other, protection against electrolysis and corrosion shall be provided. Dissimilar metals such as brass, copper or steel (except corrosion-resisting steel) shall not be used in intimate contact with aluminum or aluminum alloy. Corrosion-resisting steel shall be passivated in accordance with SAE-AMS2700. Protective measures for dissimilar metals shall be in accordance with MIL-STD-889.

3.4 Design and construction. The fitting shall be designed to meet the requirements specified herein and in the applicable specification sheet. The end fittings shall be suitable for use with hose in accordance with MIL-DTL-83797 to form flexible hose assemblies which meet the performance requirements of MIL-DTL-83796.

3.4.1 Fitting materials. Fitting materials shall be as specified in [table I](#).

3.4.2 Finish.

3.4.2.1 Carbon steel fitting finish (except corrosion resistant steel).

MIL-DTL-83798D
w/AMENDMENT 3

- a. Cadmium plating. Cadmium plating shall be in accordance with SAE-AMS-QQ-P-416, type and class optional. Fluid passages, other openings and internal threads shall not be subject to the plating thickness requirement and may have bare areas provided they are protected with a light film of oil.
- b. Zinc platings.
 - (1) Zinc plating shall be in accordance with ASTM B633; type II or III, Fe/Zn 5, or ASTM B695, type II, class 5. Both zinc platings specified in ASTM B633, type III and ASTM B695, type II, shall meet the same 96-hour salt spray test endurance as ASTM B633, type II, zinc plating.
 - (2) Zinc plating in shall be in accordance with ASTM B633, type VI, Fe/Zn 5.
 - (3) Zinc phosphate. Zinc phosphate shall be in accordance with MIL-DTL-16232, type Z and shall be hexavalent chromium free.
 - (4) Zinc nickel shall be in accordance with SAE-AMS2417, type 1.
- c. Chemical film. Naval Air Systems Command (NAVAIR) trivalent chromate pretreatment (TCP) in accordance with MIL-DTL-81706, type II, class 1A, material form (I through VI), application methods A, B, or C. Example of a PIN: M817062A3C. NAVAIR TCP may be used on a wide variety of metals, including: bare aluminum, anodized aluminum, zinc and zinc alloys, cadmium, corrosion resistant steel, and steel alloys. Aluminum connectors shall not be exposed to any type of heat which may alter the temper.

3.4.2.2 Corrosion resistant steel. Corrosion resistant steel shall be passivated in accordance with SAE-AMS2700, method 2.

3.4.2.3 Aluminum. Aluminum parts shall be anodized in accordance with MIL-A-8625, type II, class 2.

3.4.2.4 Titanium. Titanium shall be anodized in accordance with SAE-AMS2488, type 2 or fluoride phosphated in accordance with SAE-AMS2486.

MIL-DTL-83798D
w/AMENDMENT 3TABLE I. Material.

Component	Material	Form	Specification	Type
Socket	Aluminum alloy	Bar	SAE-AMS-QQ-A-225/9	7075- T73, T7351
			SAE-AMS4124	7075-T7351
			SAE-AMS4117 or SAE-AMS-QQ-A-200/8	6061-T651 or 6061-T6
			SAE-AMS-QQ-A-225/6	2024-T851 and T6 ^{1/}
			SAE-AMS4339	2024-T851 ^{1/}
			SAE-AMS4120	2024-T351 and T-4 ^{1/}
		Forgings	ASTM B221	7075-T73, T6, T62, or T651
			SAE-AMS4141	7075-T73
Nipple and nut Sizes -3, -4, and -5	Chrome- molybdenum steel	Bars	SAE-AMS6370	Alloy 4130
		Forgings	SAE-AMS6382	
			SAE-AMS6370	
	Corrosion resistant steel	Bars and forgings	ASTM A276	304, 316, or 321
			ASTM A564/A564M	XM-12 (15-5 PH) UNS S15500 or 603 (17-4 PH) UNS S17400
			SAE-AMS5639	SAE 30304; UNS S30400
			SAE-AMS5645	SAE 30321; UNS S32100
			SAE-AMS5647	304L; UNS S30403
			SAE-AMS5643	17-4PH
			SAE-AMS5743	AM-355
Nipple, nut and shoulder Size -6 and above	Aluminum alloy	Bar	SAE-AMS-QQ-A-225/9	7075-T73 or -T7351
			SAE-AMS4124	7075-T7351
			SAE-AMS-QQ-A-225/6	2024-T851, 2024-T6 ^{1/}
			SAE-AMS4339	2024-T851 ^{1/}
			SAE-AMS4117	6061-T6, 6061-T651
		Forgings	SAE-AMS-A-22771	7075-T73, T6, T62, or T651
			SAE-AMS-QQ-A-367	7075-T73
			SAE-AMS4141	7075-T73
Flange	Aluminum alloy	Bars	SAE-AMS-QQ-A-225/6	2024-T6
			SAE-AMS4339	2024-T851
		Forgings	SAE-AMS4133	2014-T6
Tubing	Carbon steel	Tube	SAE-AMS5050	1010
Tubing	Aluminum	Tube	ASTM B210	6061-T6
			SAE-AMS-WW-T-700/6	
			SAE-AMS4082	
			SAE-AMS4080	6061-O
Wire (Swivel nut to nipple) Sizes -3 through -32 -5	Corrosion- resistant steel	Wire	ASTM A493 or SAE-AS5685	Type 305, condition A
			ASTM A580/A580M	Type 304, condition A
Wire (Swivel nut to nipple) Size -6 and above	Aluminum	Wire	SAE-AMS-QQ-A-225/6 or SAE-AMS4120	2024-T4, 2024-T351
All	Titanium	Bars	SAE-AMS4928	6Al-4V, annealed
		Forgings		
		Wire		
		Tube		

^{1/} Not recommended for new design, for new design recommend 6061 and 7075 alloys.

MIL-DTL-83798D
w/AMENDMENT 3

3.4.2.5 Cadmium is not recommended. Carbon steel material with cadmium plating shall only be used when other materials and finishes specified in this document cannot meet performance requirements.

3.4.2.6 Plating thickness verification (cadmium and zinc). Plating thickness shall be measured in accordance with 4.8.10 and shall meet the requirements of 3.4.2.

3.4.2.7 Color identification. Color identification shall be in accordance with SAE-AS4841, except for the following:

- a. Aluminum swivel nuts shall be dyed blue on flared and yellow on flareless. Aluminum swivel flanges shall be dyed blue.
- b. Nipple, shoulder and tubes made from 6061 aluminum alloy shall be dyed blue or yellow.

3.4.2.8 Trivalent Wrenchability. When the finish has been damaged due to poor wrenchability, the surface of the connector shall be touched up using the brush plating process below. The term "trivalent wrenchability" is used to evaluate the ability of the finish to withstand abrasion from an excessive amount of wrenching

- a. Brush plating of hard chromium by electrodeposition shall be in accordance with SAE-AMS2451/5.
- b. Brush plating of medium-hardness, low stress nickel by electrodeposition shall be in accordance with SAE-AMS2451/9.
- c. Brush plating of NAVAIR TCP shall be in accordance with MIL-DTL-81706, type 2, class A, material form I through VI, application method B. Example of a PIN: M817062A6B.

3.4.3. Surface roughness. Surface roughness of machined parts shall not exceed 125 μ -in Ra, except for the sealing surfaces of fittings which shall not have annular tool marks in excess of 60 μ -in Ra. Ra values shall be interpreted in accordance with ASME B46.1.

3.4.4 Heat treatment. Aluminum parts shall be supplied in the final temper shown on the applicable specification sheet. Process control shall be in accordance with SAE-AMS2770.

3.4.5 Screw threads. Threads for the swivel nut shall be in accordance with SAE-AS8879.

3.4.6 Mating. The fittings shall mate with adapter ends designed in accordance with SAE-AS33514 for flareless, SAE-AS4395 for flared or with MS33786 for flanged connections, as applicable.

3.5 Performance.

3.5.1 Examination of product. The fitting shall conform to the requirements of 3.5.1.1, 3.5.1.2, and 3.5.1.3, and the applicable specification sheet, when examined in 4.8.1.

3.5.1.1 Cleanliness. The fittings shall be free of all foreign material, both internally and externally, which could adversely affect performance and reliability when examined as specified in 4.8.1.1.

3.5.1.2 Dimensions. The fitting shall conform to the dimensions specified herein and on the applicable drawing when examined as specified in 4.8.1.2.

MIL-DTL-83798D
w/AMENDMENT 3

3.5.1.2.1 Hose insertion gage. The socket of the fitting shall contain a groove no wider than .035 inch (0.89 mm) around its circumference on the edges of the hexagon. The distance from the center of the groove to the unthreaded end of socket shall be equal to the recommended depth of insertion of the hose into the socket at the time of assembly.

3.5.1.2.2 Measurement for field attachability. The fittings shall be capable of being attached to the hose with common standard tools such as vise and wrench. The method of determining proper tightening of the socket shall be by measurement of the gap between the socket and the nipple/elbow with a feeler gage. The maximum allowable gap shall be .041 inch (1.04 mm) for sizes -3, -4, and -5; .031 inch (0.79 mm) for size -6 and larger.

3.5.1.3 Weight. The fitting shall conform to the weight requirements specified on the applicable specification sheet.

3.5.2 Field attachability. The hose assembly fittings shall not separate from the hose or show any evidence of leakage around the fitting, when tested in 4.8.2.

3.5.3 Over-tightening torque. The end fitting of the hose assembly shall not show any evidence of material failure, thread damage, deformation or difficulty in turning the swivel nut on the nipple by hand, when tested in 4.8.3.

3.5.4 Bulge test. The gage shall fall through the bulge under the fitting of its own weight, when tested in 4.8.4.

3.5.5 Proof pressure. The hose assembly shall not leak or fail during or at the completion of the test, as specified in 4.8.5, with the applicable proof pressure specified in table II. There shall be no visual evidence of damage or permanent deformation.

TABLE II. Physical requirements of fittings and hose assemblies. 1/

Hose size	Operating pressure (Max) psig (MPa)	Proof pressure psig (MPa)	Burst pressure (min) psig (MPa)	Operating temperature (fluid or ambient)
-03	1,000 (6.9)	3,000 (20.7)	6,000 (41.4)	-65°F to +250°F (-54°C to 121°C)
-04	1,000 (6.9)	3,000 (20.7)	6,000 (41.4)	
-05	1,000 (6.9)	3,000 (20.7)	6,000 (41.4)	
-06	1,000 (6.9)	3,000 (20.7)	6,000 (41.4)	
-08	1,000 (6.9)	2,500 (17.2)	5,000(34.5)	
-10	1,000 (6.9)	2,500 (17.2)	5,000 (34.5)	
-12	1,000 (6.9)	2,000 (13.8)	3,750 (25.9)	
-16	750 (5.2)	1,500 (10.3)	2,500 (17.2)	
-20	500 (3.4)	1,300 (9.0)	2,000 (13.8)	
-24	250 (1.7)	800 (5.5)	1,750 (12.1)	
-32	200 (1.4)	600 (4.1)	1,200 (8.3)	

1/ Assemblies having aluminum flange fittings shall be pressure tested at the rated proof pressure or 1,500 psig (10.3 MPa), whichever is less, see MS20756.

3.5.6 Oil circulation. The hose assembly shall show no evidence of leakage or deterioration, when tested in 4.8.6.

MIL-DTL-83798D
w/AMENDMENT 3

3.5.7 Leakage. The hose assembly shall show no evidence of leakage from the fitting, through the hose or other malfunction, when tested in [4.8.7](#).

3.5.8 Corrosion. The hose assembly shall show no evidence of leakage, when tested as specified in [4.8.8](#).

3.5.9 Burst pressure. The hose assembly shall show no leakage, burst, or a fitting blow-off below the minimum burst pressure specified in [table II](#), when tested in [4.8.9](#).

3.5.10 Plating thickness verification (steel parts only). Plating thickness shall be measured in accordance with [4.8.10](#) and shall meet the requirements of [3.4.2](#).

3.6 Identification of product. Fittings shall be identified in accordance with MIL-STD-130. In addition, the fittings shall be permanently marked with:

- a. Manufacturer's identification, CAGE code, or trademark.
- b. PIN of the fitting, including dash size (see MIL-DTL-83798/1 through MIL-DTL-83798/9).

3.7 Cleanliness. All fittings shall be free of contaminants both internally and externally. Fittings, hoses, and hose assemblies shall be properly cleaned prior to inspection, testing, and shipping.

3.8 Workmanship. Fittings shall be free from burrs and tool marks. All sealing surfaces shall be smooth.

4. VERIFICATION

4.1 Classification of inspection. The inspection requirements specified herein are classified as follows:

- a. Qualification inspection (see [4.5](#)).
- b. Conformance inspection (see [4.6](#)).

4.2 Inspection conditions. Unless otherwise specified, all required inspections shall be performed in accordance with the test conditions specified in [4.7.3](#).

4.3 Test equipment and inspection facilities. Test and measuring equipment and inspection facilities of sufficient accuracy, quality, and quantity to permit performance of the required inspection shall be established and maintained by the contractor. The establishment and maintenance of a calibration system to control the accuracy of the measuring and test equipment shall be in accordance with ISO 17025 and NCSL Z540.3 as applicable.

4.4 Responsibility for compliance. All items shall meet all requirements of sections [3](#), [4](#), and [5](#). The inspection set forth in this specification shall become a part of the contractor's overall inspection system or quality program. The absence of any inspection requirements in the specification shall not relieve the contractor of the responsibility of ensuring that all products or supplies submitted to the Government for acceptance comply with all requirements of the contract. Sampling inspection, as part of manufacturing operations, is an acceptable practice to ascertain conformance to requirements, however, this does not authorize submission of known defective material, either indicated or actual, nor does it commit the Government to accept defective material.

MIL-DTL-83798D
w/AMENDMENT 3

4.5 Qualification inspection. Qualification inspection shall be performed at a laboratory acceptable to the qualifying activity on sample units produced with equipment and procedures used in production.

4.5.1 Qualification inspection routine. Samples shall be subjected to qualification testing as specified in [table III](#) in the sequence specified in [table IV](#).

4.5.1.1 Samples for qualification. Qualification samples shall be representative of the products proposed to be furnished to this specification. Samples shall consist of sufficient end fittings to permit the fabrication of 10 hose assemblies of each size and of the lengths specified in [table IV](#). The samples shall be hose in accordance with MIL-DTL-83797 and assembled with end fittings of the same size. Fittings shall be qualified with hose from a minimum of two specific current qualified hose manufacturer(s).

4.5.1.2 Configuration of samples. Each size of fitting shall be performance tested to the tests specified in [table III](#). The following details shall apply:

- a. The tests shall be performed on MIL-DTL-83798/1 straight type swivel end fittings, except samples number 9 and 10 shall have a MIL-DTL-83798/3 and MIL-DTL-83798/7 through MIL-DTL-83798/9 in the sizes tested.
- b. Two additional assemblies having MIL-DTL-83798/4 flareless style fitting ends of the sizes to be tested shall be examined as specified in 4.7.1, proof pressure (4.7.5), oil circulation (4.7.6), and burst resistance (4.7.9) tested.
- c. Satisfactory test results on these fittings shall constitute approval of fittings MIL-DTL-83798/4 through MIL-DTL-83798/6 in the sizes inspected.
- d. The hose for the test samples shall be obtained from two hose manufacturers listed or approved for listing in the applicable Qualified Products List (QPL).
- e. The hose of each manufacturer shall be on 50 percent of the samples in [table IV](#).
- f. When there is only one qualified hose manufacturer, the total quantity of samples in [table IV](#) shall be on the hose of one manufacturer.

TABLE III. Qualification inspection.

Requirement	Requirement paragraph	Test method paragraph
Examination of product	3.5.1	4.8.1
Verification of fitting plating thickness <u>1/</u>	3.5.10	4.8.10
Bulge test	3.5.4	4.8.4
Field attachability <u>2/</u>	3.5.2	4.8.2
Over-tightening torque <u>2/</u>	3.5.3	4.8.3
Proof pressure	3.5.5	4.8.5
Oil circulation <u>2/</u>	3.5.6	4.8.6
Leakage <u>2/</u>	3.5.7	4.8.7
Burst pressure <u>2/</u>	3.5.9	4.8.9
Corrosion resistance <u>2/</u>	3.5.8	4.8.8

1/ Test report may be supplied by plating manufacturer.

2/ These are destructive tests.

MIL-DTL-83798D
w/AMENDMENT 3TABLE IV. Qualification inspection sequence.

Inspection requirements	Sample number and sample hose length					
	Fitting	Hose assembly				
	1, 2, 3, 4 1/	5, 6 18 inch (45.7 cm)	7, 8 2/ 18 inch (45.7 cm)	9, 10 18 inch (45.7 cm)	11, 12 18 inch (45.7 cm)	13, 14 3/ 18 inch (45.7 cm)
Examination of product	X	X	X	X	X	X
Field attachability		X	X	X	X	X
Over-tightening torque	X					
Bulge test		X				
Proof pressure		X	X	X	X	X
Oil circulation					X	
Leakage			X			X
Corrosion			X			
Burst pressure			X			X

1/ Two flared type fittings and two flareless type fitting samples.

2/ Sample shall have a 90° elbow fitting on one end of the hose assembly.

3/ These samples are flareless type fittings.

4.5.2 Alternate qualification inspection criteria. Fittings shall meet the requirements of 4.5. Alternatively, when the identical hose is manufactured and tested in accordance with MIL-DTL-83797, and the identical hose assemblies are manufactured and tested in accordance with MIL-DTL-83796, using identical fittings in accordance with MIL-DTL-83798, it is not necessary to test the fittings to meet the qualification requirements of this specification. This applies when substantially identical test requirements and test procedures are required for the assembly and the individual components and upon documented approval by the qualifying activity.

4.5.3 Failures. One or more failures shall be cause for refusal to grant qualification approval.

4.6 Conformance inspection.

4.6.1 Sampling inspection (inspection of product for delivery). Sampling inspection shall consist of the tests specified in table V. The inspection sample s shall be selected at random from the production lot without regard to quality and the sample size shall be as specified in table VI.

TABLE V. Sampling and P1 inspections. 1/

Requirement	Requirement paragraph	Test method	Sampling	P1 2/
Examination of product	3.5.1.1 and 3.5.1.2	4.8.1	X	
Proof pressure	3.5.5	4.8.5		X
Leakage	3.5.7	4.8.7		X
Burst pressure	3.5.9	4.8.9		X

1/ If there are no reported failures after two consecutive intervals then periodic testing can be done at 24 months intervals. If there are no reported failures after the next 24 month interval, then periodic testing can be done at 36 months intervals.

2/ These are destructive tests.

MIL-DTL-83798D
w/AMENDMENT 3

4.6.1.1 Nonconformance of sampling tests. If one or more defects are identified, then the entire production lot shall be screened for that defect and all defective fittings shall be removed. A second inspection sample shall then be selected and the sampling tests shall be performed again. If one or more defects are identified from the second inspection lot, then the entire production lot shall be rejected and not supplied to this specification.

4.6.2 P1 inspection tests. Fittings shall be randomly selected from a production lot to form an inspection sample.

TABLE VI. Inspection sample.

Production lot size	Sample size
1 to 8	all
9 to 90	8
91 to 150	12
151 to 280	19
281 to 500	21
501 to 1,200	27
1201 to 3,200	35
3201 to 10,000	38
10,001 to 35,000	46

4.6.2.1 P1 inspection samples. A production lot that has passed examination of product (see 4.8.1) shall be subjected to P1 inspections as specified in table V. The P1 inspections shall be performed on 3 assemblies (6 fittings) for each size at least once per year regardless of the total number of fittings produced. At least 3 of the 6 fittings, used for testing, shall be flared fittings with the greatest bend angle. If no flared fittings were produced, flareless fittings shall be used. The 6 fittings selected shall be as representative as possible of those produced during the period in terms of fitting material and joint configuration. If there has been no production for a particular size, during the past year, P1 inspections are not required for that size.

4.6.2.2 P1 inspections performed at bulk hose or assembly level. Required P1 inspections tests at the fitting level that were already performed at the bulk hose or assembly level may be eliminated if documented approval has been obtained from the qualifying activity.

4.6.2.3 Nonconformance of P1 inspections. If a sample fails any P1 inspection test, acceptance and shipment of the product shall be discontinued until corrective action acceptable to the qualifying activity has been taken. After the corrective action has been taken, sampling or P1 inspection, see table V, shall be repeated on additional samples. At the discretion of the qualifying activity this may include all sampling or P1 inspections, or the inspection which the original sample failed. However final acceptance of the hose or hose assemblies shall be withheld until the P1 inspection has shown that the corrective action was successful.

4.6.2.4 Disposition of P1 test specimens. Test specimens which have been subjected to P1 testing are considered damaged and shall not be delivered on a contract or purchase order.

4.6.3 P2 inspections. P2 inspections as specified in table VII, shall be performed on two fittings at least once per year regardless of the total number of fittings produced. The fittings shall be of any bend angle and joint configuration. The two fittings selected shall be as representative as possible of those produced during the period, in terms of material used for the threaded parts. The size of the two fittings shall be determined based on the fitting size that is most likely to fail if there was a defect. If there has been no production during the past year, P2 inspections are not required.

MIL-DTL-83798D
w/AMENDMENT 3

TABLE VII. P2 inspections. ^{1/}

Requirement	Requirement paragraph	Test method
Over-tightening torque	3.5.3	4.8.3

^{1/} If there are no reported failures after two consecutive intervals then periodic testing can be done at 24 months intervals. If there are no reported failures after the next 24 month interval, then periodic testing can be done at 36 months intervals.

4.6.3.1 Disposition of test specimens. Test specimens, which have been subjected to P2 inspection testing, are considered damaged and shall not be delivered on a contract or purchase order.

4.6.3.2 Nonconformance of P2. If a sample fails the P2 inspection test, acceptance and shipment of the product shall be discontinued until corrective action acceptable to the qualifying activity has been taken. After the corrective action has been taken P2 inspection, see [table VII](#), shall be repeated on additional samples. At the discretion of the qualifying activity this may include all inspections, or the inspection which the original sample failed. Sampling and P1 inspections may be reinstated. However final acceptance of the hose or hose assemblies shall be withheld until the P2 inspection has shown that the corrective action was successful.

4.6.3.3 Alternate conformance inspection criteria. When the identical hose is manufactured and tested in accordance with MIL-DTL-83797, and the identical hose assemblies manufactured and tested in accordance with MIL-DTL-83796, using identical fittings in accordance with MIL-DTL-83798, it is not necessary to test the fittings to meet the conformance inspection data requirements of this specification. This applies when substantially identical test requirements and test procedures are required for the assembly and the individual components and upon documented approval by the qualifying activity.

4.7 Additional QPL test and reporting requirements.

4.7.1 Retention of qualification. To retain qualification, the contractor shall submit a test report to the qualifying activity at 12 month intervals. The qualifying activity shall establish the initial reporting date. Each report shall consist of a summary of test and inspection results required by this specification that were performed during the 12 month reporting interval. As a minimum, the report shall include the following:

- a. Number of lots produced and tested, including lot and sample sizes for each lot.
- b. Identify which tests were performed.
- c. Quantities passed.
- d. Quantities failed.
- e. All reworked sampling lots shall be accounted for and identified. A summary of corrective action taken shall be included.

4.7.2 Loss of product qualification.

4.7.2.1 Failure to meet test requirements. The manufacturer shall immediately notify the qualifying activity at any time during the 12-month reporting period when the qualified product fails to meet the test and inspection requirements of this specification. The manufacturer shall identify and indicate what corrective action will be taken to correct the problem. Failure to take corrective action acceptable to the qualifying activity may result in removal of the product from the QPL.

MIL-DTL-83798D
w/AMENDMENT 3

4.7.2.2 Failure to submit summary test data report. Failure to submit a report within 30 days after the end of the 12 month reporting period may result in loss of qualification for the product.

4.7.2.3 Change to manufacturing process, materials or equipment. The manufacturer shall notify the qualifying activity, in writing, of any changes in the manufacturing process, materials, or equipment used to manufacture a QPL product. Subsequently, the qualifying activity will notify the manufacturer, in writing, if a full re-qualification, partial re-qualification, or no additional testing is required as a result of these changes.

4.7.2.4 No production during reporting period (12 months). When no production occurs during the reporting period, a report shall be submitted to the qualifying activity certifying that the manufacturer still has the capability and facilities necessary to produce the QPL product.

4.7.3 Test conditions.

4.7.3.1 Test fluids. Unless otherwise specified in the test, the test fluid shall be oil in accordance with MIL-PRF-7808 or hydraulic fluid in accordance with MIL-PRF-5606, MIL-PRF-83282, MIL-PRF-87257 or water.

WARNING!!!!

Some of the petroleum and synthetic type hydraulic oils/fluids often contain tricresyl phosphate (TCP) as additives, which is readily absorbed by the skin and is toxic. Any portion of the body that comes in contact with these oils/fluids should be cleaned as soon as possible. If skin or eye contact can be anticipated, appropriate protective equipment should be worn.

4.7.3.2 Fitting and hose assemblies. Unless otherwise specified, fittings to be tested shall be attached to each end of a hose in accordance with MIL-DTL-83797. The hose assembly shall be fabricated as specified in MIL-DTL-83796 and MIL-DTL-83796/1 through MIL-DTL-83796/18. The hose shall be inserted into the socket to the depth of the groove on the socket. The fitting shall be attached to the hose with standard tools. The maximum allowable gap between the socket and the nipple/elbow is .041 inch (1.04 mm) for fitting sizes -3, -4, and -5 and .031 inch (0.79 mm) for sizes -6 and larger.

4.8 Test methods.

4.8.1 Examination of product. The fitting shall be examined for identification markings and workmanship. Conformance shall be as specified in [3.5.1](#).

4.8.1.1 Cleanliness. The fitting shall be visually examined internally and externally for conformance to the requirements specified in [3.5.1.1](#).

4.8.1.2 Dimensions. The fitting shall be checked dimensionally to determine conformance to the dimensions specified herein and on the applicable specification sheet. Conformance shall be as specified in [3.5.1.2](#).

4.8.1.3 Weight (see [3.5.1.3](#)). The fitting shall be checked to determine conformance to the weight requirements specified on the applicable specification sheet. Conformance shall be as specified in [3.5.1.3](#).

4.8.2 Field attachability (see [3.5.2](#)). The field attachability of the fitting to the hose shall be a requirement of the tests of this specification where test procedure requires a hose assembly. A fitting shall be attached to each end of a length of bulk hose as specified in [4.6.2](#). The hose assembly length

MIL-DTL-83798D
w/AMENDMENT 3

shall be specified in IV. These hose assemblies shall be used for performing the tests of this specification. Conformance shall be as specified in [3.5.2](#).

4.8.3 Over-tightening torque (see [3.5.3](#)). Flared and flareless type fitting when subjected to over-tightening torque in accordance with SAE-ARP908 shall meet the requirements of [3.5.3](#). The flared and flareless type fittings shall be installed on mating adapter ends SAE-AS4395 or SAE-AS33514 as applicable.

4.8.4 Bulge test (see [3.5.4](#)). Hose assemblies shall be measured for bulging of the hose inner tube caused by the attachment of the hose to the adapter and shall meet the requirements of [3.5.4](#). The following details shall apply:

- a. The ball gauges shall be as specified in [table VIII](#).
- b. Holding the hose in a vertical position, the gauge is inserted into the end of the hose assembly at the bulge inspection point C shown on [figure 1](#).
- c. The gauge shall fall through the section at the end of the adapter in the hose under its own weight without lubrication and without forcing the gauge through the adapter-to-hose interfacing section.

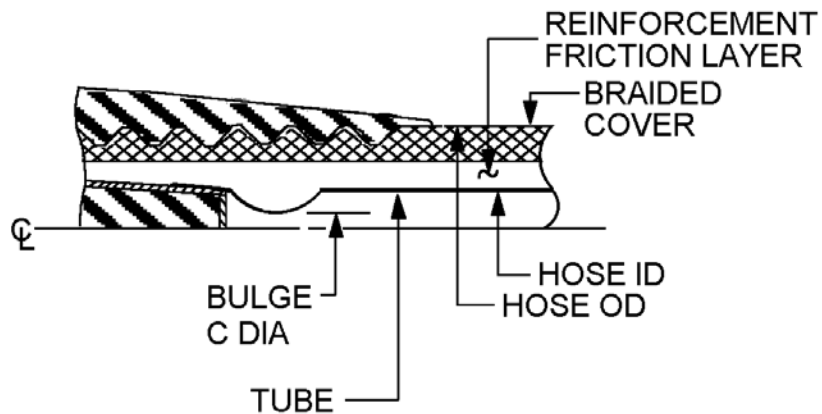

FIGURE 1. Inner tube bulge.

MIL-DTL-83798D
w/AMENDMENT 3TABLE VIII. Ball gauges. 1/ 2/ 3/

Hose size dash number	Ball diameter for straight fittings inches (mm)
-3	.094 (2.39)
-4	.141 (3.58)
-5	.203 (5.16)
-6	.266 (6.76)
-8	.344 (8.74)
-10	.469 (11.91)
-12	.563 (14.30)
-16	.750 (19.05)
-20	1.000 (25.4)
-24	1.250 (31.75)
-32	1.625 (41.28)
-40	2.232 (56.69)
-48	2.714 (68.93)

1/ Dimensions are in inches.

2/ Metric equivalents are given for information only.

3/ Steel balls are used to ensure that hoses are free of debris and bulging rubber.

4.8.5 Proof pressure(see [3.5.5](#)). Each hose assembly shall be tested in accordance with ASTM D380 and subjected to the applicable proof pressure listed in [table II](#). Each hose assembly shall meet the requirements of [3.5.5](#). The test fluid shall be water or fluid in accordance with MIL-PRF-5606, MIL-PRF-83282 or MIL-PRF-87257.

“CAUTION: Use safety precautions. Fuel and oil under pressure and at high temperature may self ignite or explode.”

4.8.6 Oil circulation (see [3.5.6](#)). The hose assemblies when subjected to oil circulation shall meet the requirements of [3.5.6](#). The following details shall apply:

- a. Hose assemblies shall be installed in a test set-up similar to that shown on [figure 2](#).
- b. The test fluid shall be oil in accordance with MIL-PRF-7808.
- c. The following test sequence procedure, see [figure 3](#), shall be performed:
 - (1) Soak the assemblies with no pressure in a cold chamber, the temperature of which shall be controlled at $-65^{\circ}\text{F} \pm 2^{\circ}\text{F}$ ($-53.9^{\circ}\text{C} \pm 1.1^{\circ}\text{C}$), and maintained at this temperature for 1 hour.
 - (2) Pressure-test the assemblies to the operating pressure specified in [table II](#) for 30 seconds.
 - (3) Circulate the test fluid at a pressure of 70 psig (4.8 bar) and at a flow rate not to exceed 15 feet per second (4.6 meters per second).
 - (4) While circulating the fluid, increase the temperature of the test fluid to $250^{\circ}\text{F} \pm 10^{\circ}\text{F}$ ($121.1^{\circ}\text{C} \pm 5.6^{\circ}\text{C}$), and increase the ambient temperature of $200^{\circ}\text{F} \pm 10^{\circ}\text{F}$ ($93.3^{\circ}\text{C} \pm 5.6^{\circ}\text{C}$).

MIL-DTL-83798D
w/AMENDMENT 3

- (5) Continue circulation for 20 hours. During the last hour of the 20-hour period, increase the test fluid temperature to $375^{\circ}\text{F} \pm 10^{\circ}\text{F}$ ($190.6^{\circ}\text{C} \pm 5.6^{\circ}\text{C}$). This temperature shall be maintained a minimum of 15 minutes.

“CAUTION: Use safety precautions. Fuel and oil under pressure and at high temperature may self ignite or explode.”

- (6) Upon completion of above procedures, reduce the fluid and ambient temperature to room temperature, and test the assembly to the applicable operating pressure, see [table II](#) for a minimum of 30 seconds.
- d. The test sequence procedures (1) through (6) above constitute one cycle. Complete 10 cycles. Upon completion of the 10 cycles, pressure-test the hose assemblies at the applicable operating pressure, see [table II](#), for a minimum of 3 minutes.

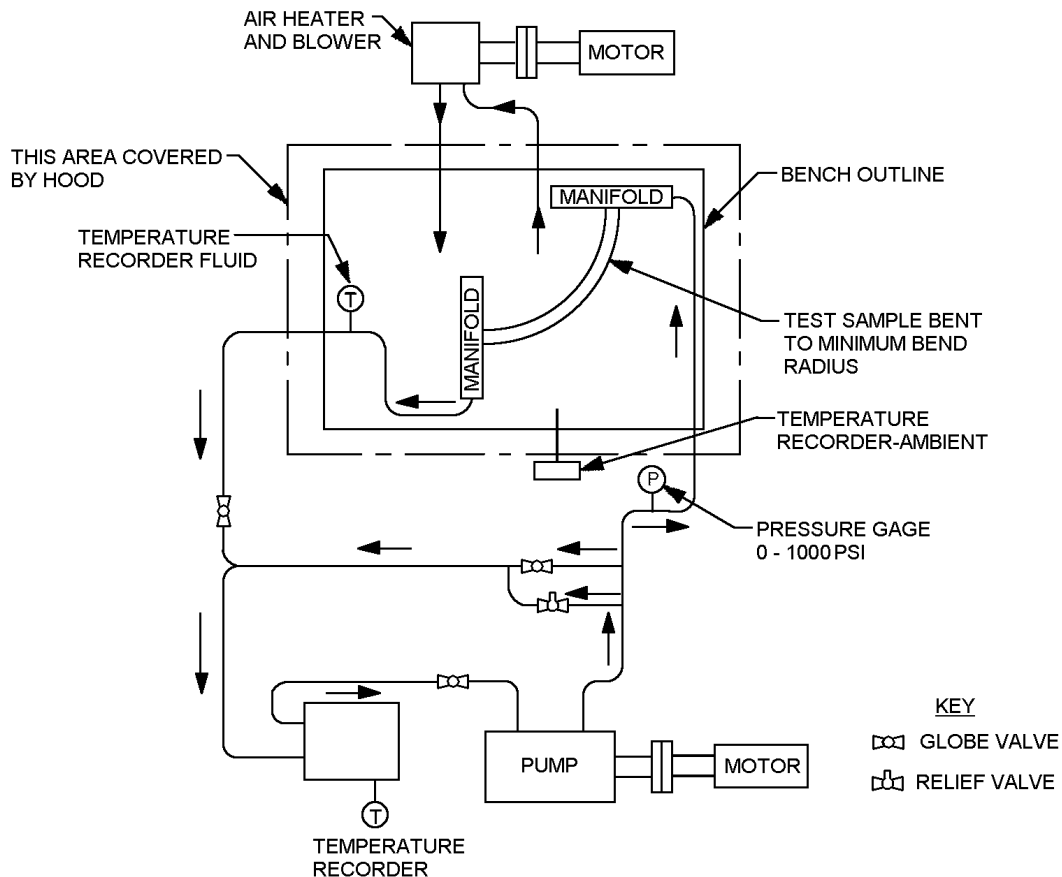

FIGURE 2. Oil circulation test schematic.

MIL-DTL-83798D
w/AMENDMENT 3

Hose size	Bend radius (min) inches (mm)
-03	1.75 (44.45)
-04	2.00 (50.80)
-05	2.25 (57.15)
-06	2.50 (63.50)
-08	3.50 (88.90)
-10	4.00 (101.60)
-12	4.50 (114.30)
-16	5.50 (139.70)
-20	8.00 (203.20)
-24	9.00 (228.60)
-32	12.50 (317.50)

NOTES:

1. Dimensions are in inches.
2. Metric equivalents are given for information only.

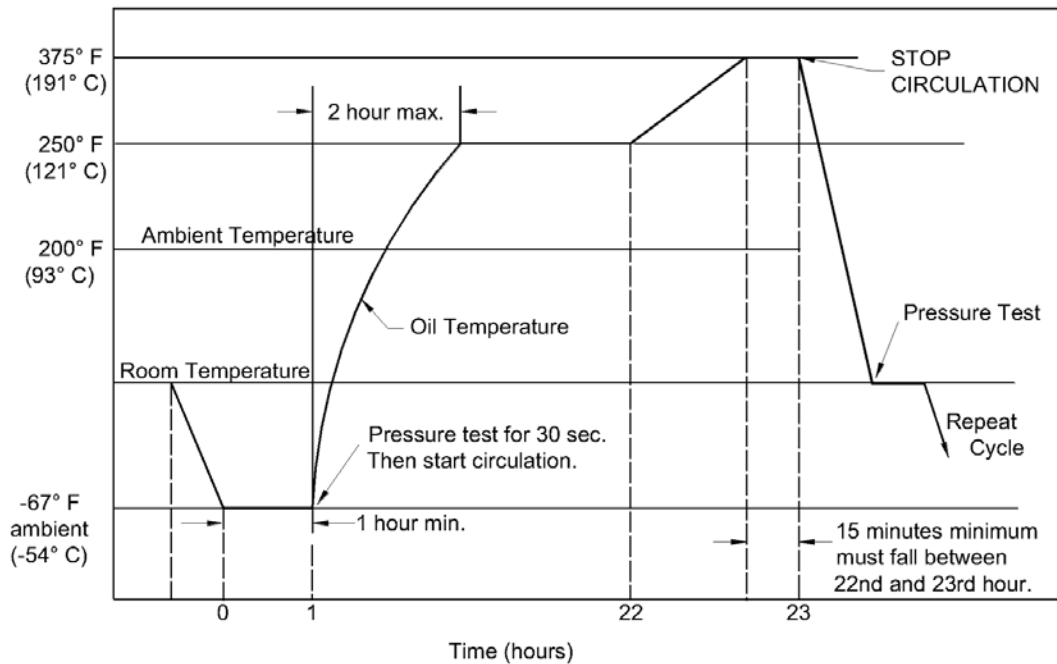
FIGURE 2. Oil circulation test schematic - Continued.FIGURE 3. Oil circulation (time and temperature schedule).

MIL-DTL-83798D
w/AMENDMENT 3

4.8.7 Leakage (see 3.5.7). Two un-aged hose assemblies shall be tested as specified in ASTM D380 and meet the requirements of 3.5.7. The following details shall apply:

- a. The samples shall be a minimum of 18 inches (45.7 cm) in length.
- b. Test fluid shall be water or hydraulic fluid in accordance with MIL-PRF-5606, MIL-PRF-83282 or MIL-PRF-87257.
- c. Samples shall be subjected to 70% of the minimum burst pressure as specified in [table II](#) and held for 5 minutes.
- d. After 5 minutes, the pressure shall be released and reduced to zero. Then the pressure shall be raised again to 70% of the minimum burst pressure and held for another 5 minutes.
- e. The adjacent outer cover shall be carefully inspected during this period for any wicking or leakage of the test fluid.
- f. After completion of the leakage test on these samples, they shall be subjected to the burst pressure test specified in [4.8.9](#).

4.8.8 Corrosion (see 3.5.8). Hose assemblies shall be subjected to corrosion test and shall meet the requirements of 3.5.8. The following details shall apply:

- a. Hose assemblies shall be immersed, in a vertical position with the ends capped, into a 2.5 percent solution of sodium chloride for a minimum of five minutes.
- b. The samples shall then be air dried for 25 minutes at a temperature of 140 ± 5 °F.
- c. This immersion and drying cycle shall be repeated for a total of 168 hours.
- d. Upon completion of this test the hose assemblies shall be subjected to the burst pressure test (see [4.8.9](#)).

4.8.9 Burst pressure see 3.5.9). Two un-aged hose assemblies, within 24 hours after assembly, shall be subjected to the burst pressure test specified in [table II](#) and shall meet the requirements of 3.5.9. The following details shall apply:

- a. The assemblies shall be a minimum of 18 inches (45.7 cm) in length.
- b. During this test, the hose assembly shall be fastened at one end to the source of pressure, the hose shall be extended straight, and the free end shall not be restrained or fastened in any way.
- c. Test fluid shall be water or hydraulic fluid in accordance with MIL-PRF 5606, MIL-PRF-83282 or MIL-PRF-87257.
- d. The rate of pressure rise shall be 25,000 \pm 10,000 psig per minute (1723.7 bar \pm 689.5 bar per minute).
- e. Pressure shall be applied until failure occurs.
- f. The actual pressure at which the samples burst or otherwise fail shall be recorded and record the site of the burst.

4.8.10 Verification of fitting plating thickness cadmium or zinc (see 3.4.2.6). Verification of under plating and finish plating shall be measured in accordance with ASTM B499, ASTM B567, or ASTM B568. A cross-sectioning method, such as that specified in ASTM B487 or ASTM B748, can also be used as a referee method to confirm the precision when thicknesses of 30 microinches (0.76 μ m) or above are used. The plating thickness requirements shall meet the requirements of 3.4.2.6. The zinc plating thickness may also be measured in accordance with ASTM B633 or ASTM B695 as applicable. The following details shall apply:

- a. When applicable a minimum of three points shall be measured on the fitting surface. The fitting may be rotated, but measurement points shall be progressively further from the last point. Readings shall not be averaged. Measurements shall be as follows:
 - (1) One measurement shall be taken at a point on the front radius and rear radius.
 - (2) Three measurements shall be taken in the middle areas.

MIL-DTL-83798D
w/AMENDMENT 3

5. PACKAGING

5.1 Packaging. For acquisition purposes, the packaging requirements shall be as specified in the contract or order (see 6.2). When packaging of material is to be performed by DoD or in-house contractor personnel, these personnel need to contact the responsible packaging activity to ascertain packaging requirements. Packaging requirements are maintained by the Inventory Control Point's packaging activity within the Military Service or Defense Agency, or within the Military Service's System Commands. Packaging data retrieval is available from the managing Military Department's or Defense Agency's automated packaging files, CD-ROM products, or by contacting the responsible packaging activity.

6. NOTES

(This section contains information of a general or explanatory nature which may be helpful, but is not mandatory).

6.1 Intended use. The fittings covered by this specification are intended for hose assemblies used in military aircraft lubricating and fuel systems. These systems are required to withstand temperatures between -65°F to +250°F (-53.9°C to 121.1°C) and operate at pressures up to 1000 psig (6.9 MPa).

6.1.1 Military unique rationale. The rubber hose assemblies described by this specification require qualification (material, part, and process), and on site audits, which include traceability of parts. The rubber hose assemblies must be capable of interoperability and compatibility, which can only be assured through strict adherence to the detail specification sheet requirements. Commercial parts are not designed to be interchangeable with aircraft hydraulic systems.

6.2 Acquisition requirements. Acquisition documents should specify the following:

- a. Title, number, and date of this specification.
- b. Applicable specification sheet number, title, and date.
- c. Applicable specification sheet PIN.
- d. Packaging requirements (see 5.1).

6.3 Qualification. With respect to products requiring qualification, awards will be made only for products which are, at the time of award of contract, qualified for inclusion in Qualified Products List QPL No. 83798 whether or not such products have actually been so listed by that date. The attention of contractors is called to these requirements; and manufacturers are urged to arrange to have the products that they propose to offer to the Federal Government tested for qualification in order that they may be eligible to be awarded contracts or orders for the products covered by this specification. Information pertaining to qualification of products may be obtained from DLA Land and Maritime, P.O. Box 3990, ATTN: DSCC-VQ, Columbus, Ohio 43218-3990 or emailed to vgp.chief@dla.mil. An online listing of products qualified to this specification may be found in the Qualified Products Database (QPD) at <https://assist.daps.dla.mil>.

6.3.1 Provisions governing qualification (SD-6). Copies of "Provisions Governing Qualification" are available online at <https://assist.daps.dla.mil> or from the Standardization Document Order Desk, 700 Robbins Avenue, Building 4D, Philadelphia, PA 19111-5094.

MIL-DTL-83798D
w/AMENDMENT 3

6.4 Environmentally preferable material. Environmentally preferable materials should be used to the maximum extent possible to meet the requirements of this specification. As of the dating of this document, the U.S. Environmental Protection Agency (EPA) is focusing efforts on reducing 31 priority chemicals. The list of chemicals and additional information is available on their website <http://www.epa.gov/osw/hazard/wastemin/priority.htm>. Included in the EPA list of 31 priority chemicals are cadmium, lead, and mercury. Use of these materials should be minimized or eliminated unless needed to meet the requirements specified herein (see section 3).

6.5. Guidance on use of alternative parts with less hazardous or nonhazardous materials. This specification provides for a number of alternative plating materials via the PIN. Users should select the PIN with the least hazardous material that meets the form, fit and function requirements of their application.

6.6 Subject term (key word) listing.

- Field attachability
- Flanged type
- Flared type
- Flareless type
- Fuel systems
- Oil systems
- Tricresyl phosphate

6.7 Amendment notations. The margins of this specification are marked with vertical lines to indicate modifications generated by this amendment. This was done as a convenience only and the Government assumes no liability whatsoever for any inaccuracies in these notations. Bidders and contractors are cautioned to evaluate the requirements of this document based on the entire content irrespective of the marginal notations.

CONCLUDING MATERIAL

Custodians:
Army - AV
Navy - AS
Air Force - 99
DLA - CC

Preparing activity:
DLA - CC

(Project 4730-2012-046)

Review activities:
Army - AT
Navy - MC, SA
Air Force - 11, 71

NOTE: The activities listed above were interested in this document as of the date of this document. Since organizations and responsibilities can change, you should verify the currency of the information above using the ASSIST Online data at <https://assist.daps.dla.mil>.