

NOT MEASUREMENT
SENSITIVE

MIL-DTL-83495C (USAF)
w/AMENDMENT 1
08 December 2010

SUPERSEDING
MIL-DTL-83495C
23 August 2010

DETAILED SPECIFICATION TECHNICAL MANUALS - ON-EQUIPMENT MAINTENANCE MANUAL SET



This specification is approved for use by all Departments and Agencies of the Department of Defense.

Comments (recommendations, additions, deletions) and any pertinent data which may be of use in improving this document should be submitted to: ESC/HGGI, 4170 Hebble Creek Road, Bldg. 280, Door 15, Area A, Wright-Patterson AFB, OH 45433-5653 or by email to: SGMLsupport@wpafb.af.mil. Since contact information can change, the currency of this address information should be verified using the ASSIST Online database at <https://assist.daps.dla.mil/>.

AMSC

AREA TMSS

Distribution Statement A. Approved for public release; distribution is unlimited.

**MIL-DTL-83495C (USAF)
W/AMENDMENT 1**

1 SCOPE

1.1 Scope. This specification covers the requirements for the preparation of the On-Equipment Maintenance Manual Set (OMMS) for USAF equipment. Use of Standardized System Subsystem Subject Number (SSSN) assignment in accordance with MIL-STD-1808 provides maximum cross referencing, reducing the research time required to locate needed data. DTDs, TDTs, and other files in the DSS for electronic delivery of data can be accessed at the Technical Manual Specifications and Standards (TMSS) website. see [A.4.1](#). The requirement for paper delivery of manuals is allowed in TO contracts for QA purposes only.

1.2 Detail. The level of detail contained in this Detail Specification is necessary to comply with the requirements of the Joint Computer-aided Acquisition and Logistics Support (JCALS) system.

2 APPLICABLE DOCUMENTS

2.1 General. The documents listed in this section are specified in sections 3, 4, or 5 of this specification. This section does not include documents cited in other sections of this specification or recommended for additional information or as examples. While every effort has been made to ensure the completeness of this list, document users are cautioned that they must meet all specified requirements of documents cited in sections 3, 4, or 5 of this specification, whether or not they are listed.

2.2 Government documents.

2.2.1 Specifications, standards, and handbooks. The following specifications, standards, and handbooks form a part of this document to the extent specified herein. Unless otherwise specified, the issues of these documents are those listed in the solicitation or contract (see [6.2b](#)).

DEPARTMENT OF DEFENSE STANDARDS

MIL-STD-1808	System Subsystem Sub-subsystem (SSSN) Numbering.
MIL-STD-38784.	Manuals, Technical: General Style and Format Requirements.

DEPARTMENT OF DEFENSE HANDBOOKS

MIL-HDBK-863	Wiring Data and System Schematic Diagrams, Preparation of.
MIL-HDBK-275.	Guide for Selection of Lubricant Fluids and Compounds.

(Copies of these documents are available online at <https://assist.daps.dla.mil>. or may be ordered by mail from the Standardization Documents Order Desk, 700 Robbins Avenue, Building 4D, Philadelphia, PA 19111-5094.

2.2.2 Other government documents, drawings and publications. The following other Government documents, drawings, and publications form a part of this document to the extent specified herein. Unless otherwise specified, the issues are those cited in the solicitation.

PUBLICATIONS

AIR FORCE TECHNICAL MANUALS

Technical Order (TO) 1-1-17. Storage of Aircraft and Missile Systems

(Copies of documents required by contractors in connection with specific procurement functions should be obtained from the acquiring activity or as directed by the contracting officer.)

PUBLICATIONS

TO 00-5-3. TO Life Cycle Management

(Copies can be obtained at. <http://www.tinker.af.mil/technicalorders>.)

2.3 Non-Government publications. The following document(s) form a part of this document to the extent specified herein. Unless otherwise specified, the issues of these documents are those cited in the solicitation or contract. (see [6.2](#)).

No non-government publications are cited as first tier requirements in this specification. See appendices for additional information.

2.4 Order of precedence. Unless otherwise noted herein or in the contract, in the event of a conflict between the text of this document and the references cited herein, the text of this document takes

MIL-DTL-83495C (USAF) W/AMENDMENT 1

precedence. Nothing in this document, however, supersedes applicable laws and regulations unless a specific exemption has been obtained.

3 REQUIREMENTS

3.1 General requirements.

3.1.1 Preparation requirements. The general manner of preparation and format for all manuals shall be in accordance with the requirements of MIL-STD-38784, except as modified herein.

3.1.2 Nomenclature requirements. System/subsystem nomenclatures assigned in accordance with MIL-STD-1808 shall be followed by the applicable higher level designation in a parenthesis (ref: MIL-HDBK-863). Nomenclature shall agree with the drawing title and shall be forward reading. Chapter/Section titles shall correspond with chapter/section requirements specified herein. Nomenclature shall be used consistently throughout a chapter for text and illustrations. Nomenclature appearing on decals, engraved legends, nameplates, or other markings shall be repeated verbatim on the first occurrence. All attaching hardware items involved in a task shall be specifically mentioned.

3.1.2.1 Short form use of common names. After first use, nomenclature shall be shortened as required, if there is no other name with which it can be confused. Simple identifying nomenclature shall be provided for attaching parts in both pictorial callouts and text, if appropriate.

3.1.2.2 Terminology. Only terminology that conveys the purpose, function, or nature of an item relevant to the task shall be used. Modifiers shall be used when one or more items of the same object nomenclature are acted upon in the same task. For example: A procedure to rig a spoiler center wing input quadrant includes an illustration of the unit. The presence of the illustration showing the location of the unit enables the writing of a simple task step, e.g., "Insert rig-pin." If more than one rig-pin exists, a proper modifier shall be added, e.g., "Insert lower rig-pin."

3.1.3 Diagrams. Equipment wiring data and schematic diagrams shall be developed in accordance with MIL-HDBK-863. Parallel lines on wiring data and schematic diagrams shall in no case be less than 0.10 inches apart and no less than 0.06 inches high when reduced to printed size.

3.1.4 Foldout pages. Print media requirements: Foldout pages shall be in accordance with MIL-STD-38784, unless otherwise specified herein. SSSN, figure number, and figure title for foldout pages shall be placed so they are visible when the printed page is folded.

3.1.5 Marginal copy. Print media requirements: The SSSN shall appear in the lower-outer corner of each page, directly above the page number and shall be 18-point type. The SSSN shall not be placed at the bottom of front matter pages.

3.1.6 Numbering. Chapters, sections, paragraphs, figures, and tables shall be numbered in accordance with MIL-STD-38784, except as specified herein. The SSSN shall form a part of the paragraph heading when the heading introduces an item having an SSSN assigned, e.g., "1-17 Null Amplifier (03-17-04)."

Electronic media requirements: Page count restrictions do not apply.

Print media requirements: All pages shall be numbered in accordance with MIL-STD-38784.

3.1.6.1 Use of SSSN. The SSSN shall be used as described in the following paragraphs and MILSTD-1808. When used for electronic data, the SSSN shall be used in task oriented view packages.

3.1.6.1.1 Use of "System" number. The system number is used to denote a chapter in General Equipment (GE), Fault Reporting (FR), and Fault Isolation (FI) manuals. In General System (GS) manuals, the system number is used to denote a manual (if separate manuals) or a chapter (if combined manuals). For Job Guide (JG) manuals, the system number designates the manual chapter as specified herein (see 3.4.3). Systems which are reserved or not used shall not be included in the manuals (see 3.2.3.2).

3.1.6.1.2 Use of "Subsystem" number. The subsystem number is used to denote a section in the GE, FR, and FI manuals. In GS manuals, the subsystem number is used as a reference only. For JG manuals, the system number designates a chapter within the manual(s) for that system. The contents of the chapter or section and the system separations are assigned by MIL-STD-1808. The application of the subsystem designator as shown herein must be confined to discussion of the total subsystem; e.g., material contained in

**MIL-DTL-83495C (USAF)
W/AMENDMENT 1**

34-50 would necessarily be confined to general discussion of the total Dependent Position Determining subsystem and requires the addition of zeros in the third element (34-50-00).

3.1.6.1.3 Sub-subsystem numbering. The sub-subsystem number is assigned by the manufacturer. Subsystems which contain very complex sub-subsystems may require further chapter breakout. This will be indicated by the fourth digit, such as 34-51-00. In this case, -51 would be a sub-subsystem of the Dependent Position Determining subsystem of the Navigation System. A sub-subsystem shall not be identified in the second element unless a fourth designator, different from zero (0), is assigned.

3.1.6.1.4 Task/component number numbering. This number is assigned by the manufacturer to a specific task or component. This number shall be assigned in consecutive order within the manual or view package in which it is used. For example, the fifth component covered in a JG would be XX-XX-05-XXX.

3.1.6.1.4.1 Task/component number development for JG, FR and FI manuals. The subject number assignment shall reference the SSSN in the terminal steps of the fault tree contained in the FR and FI manuals.

For example: If an FR or FI page/screen contains fault tree segments applicable to a specific item of a sub-subsystem of the Dependent Position Determining subsystem, the page/screen would reflect 34-51-00; if a page/screen contains segments of the fault tree applicable to more than one subject (general) breakdown of the Dependent Position Determining subsystem, the page/screen would reflect 34-50-00; if the page/screen contains segments of the fault tree applicable to multiple subsystems within the Navigation system, the page/screen would reflect 34-00-00.

Electronic media requirements: SSSN shall be persistently viewed in the header or footer on the screen.

Print media requirements: The SSSN shall be reflected in the lower outer corner of the FR and FI manuals. The number shall reflect the first three elements, to the lowest element possible, as allowed by the composition of the segment of the fault tree displayed on that page.

3.1.6.1.4.2 Subject number development for other than JG, FR and FI manuals. When used in view packages or other manuals, the task/component number is assigned in sequence of the system. This number is developed for manuals other than the JG, FR and FI manuals, are similar manner.

3.1.6.1.5 Function number. The function number (fourth element) shall be assigned as specified herein.

3.1.6.1.5.1 Function number requirements for JG manuals. The assignment of the function number shall follow the task/component number in the JG manual and shall be assigned as specified herein. For example, a system operational checkout will be identified as "XX-XX-XX-001".

3.1.6.1.5.2 Typical functions. The following functions shall be used for development of the function numbers and may be expanded/changed to suit equipment requirements if approved by the acquiring activity (see 3.4.3.2.1):

001 - Operational Checkout	008 - Cleaning
002 - Access	009 - Lubrication
003 - Remove	010 - Servicing
004 - Install	011 - Jacking
005 - Repair	012 - Alignment and Adjustment
006 - Rigging	013 - Calibrate
007 - Inspect	

3.1.7 Applicability codes. Applicability codes shall be listed in tables as part of the foreword. Equipment differences (equipment type-model-series and serial number) shall be annotated using flagnotes indicating the applicability code.

Print requirement: Separate pages shall be used for each effectivity where significant differences exist and flagnotes will not suffice.

3.1.8 Classified material. If classified information is essential, it shall be in accordance with MILSTD- 38784.

**MIL-DTL-83495C (USAF)
W/AMENDMENT 1**

3.1.9 References. References shall be in accordance with MIL-STD-38784 with the following exception: When using a SSSN reference to another manual in the OMMS, the SSSN shall be prefixed with the abbreviation for that manual type, e.g., reference to a SSSN in a general system (GS) manual would be shown as "GS XX-XX-XX".

3.2 General equipment (GE) manual. One GE manual shall be prepared for the equipment. When specified, a combined GE and GS manual shall be prepared (see 6.2c.). When a combined manual is prepared, all applicable chapters shall be used. The GE manual shall be written for standalone use. Detailed description and theory of operation shall not be included.

Electronic media requirements: Page count restrictions do not apply.

Print media requirements: When GE manual exceeds 800 pages (400 sheets) separate manuals shall be prepared. Combined GS and GE manuals will not exceed 800 pages (400 sheets).

3.2.1 Scope. The GE manual shall provide general information about the equipment. Specifically, it shall provide:

- a. An overview and detailed explanation of the OMMS.
- b. A functional description of the SSSN system.
- c. A listing of all equipment Time Compliance Technical Order (TO) (TCTO).
- d. An overall equipment description (effectivity (application) by model and serial number), general arrangement, principal dimensions, pictorial diagrams (e.g., access, danger areas, equipment location, cable routing), station diagrams, etc.
- e. A summary description of all equipment systems, supported by artwork.
- f. Non-JG information applicable to more than one system.
- g. Non-JG guide formatted information and instructions that are generally applicable to all systems.
- h. General information on the interface between systems and integration of two or more systems.

3.2.2 Page size. Electronic media requirements: Page size requirements do not apply.

Print media requirements: The GE manuals shall be prepared in 8½ by 11 inch page size.

3.2.3 Arrangement. This specification refers to "systems" as chapters, e.g., System 00 in MIL-STD-1808 is Chapter 00 herein.

Electronic media requirement: The book shall be chunked by chapters. The basic contents of the GE manual and its arrangement shall be as shown below.

Front Matter

Chapter 00	General Equipment Description
Chapter 1	Reserved
Chapter 2	Reserved
Chapter 3	Reserved
Chapter 4	Reserved
Chapter 5	Time Limits/Maintenance Checks (For Reference Only)
Chapter 6	Dimensions and Areas
Chapter 7	Lifting, Shoring, Recovering, and Transporting
Chapter 8	Leveling and Weighing (For Reference Only)
Chapter 9	Towing and Taxiing
Chapter 10	Parking and Mooring
Chapter 11	Placards and Markings
Chapter 12	Servicing

**MIL-DTL-83495C (USAF)
W/AMENDMENT 1**

Chapter 13	Equipment Storage
Chapter 14	Corrosion Control
Chapter 15	Non-destructive Inspection
Chapter 16	Siting Installation
Chapter 17	Preparation for Use and Shipment
Chapter 18	Weapons Instrumentation
Chapter 19	Training Equipment

3.2.3.1 Front matter. Front matter shall be prepared in accordance with MIL-STD-38784 and applicable requirements specified herein (see 3.1).

3.2.3.1.1 Foreword. The foreword shall identify the equipment applicability by Government or manufacturers type designation and provide a brief explanation of the manual's purpose, scope and arrangement, including any relevant information that will increase the usability of the manual. An explanation of "shall," "will," "should," and "may" as defined in MIL-STD-38784 shall be provided. An overview and detailed explanation of the OMMS use, TO numbering and assignment of higher level designations (see MIL-HDBK-863) as they relate to a functional system, definition of a functional system, and a detailed explanation and intended use of each type manual shall be provided. Illustrations shall be used to assist in explanation, as required.

3.2.3.2 Chapters. Chapters shall be constructed in accordance with MIL-STD-1808 numbering. Chapter numbers shall remain as specified in 3.2.3, however, the table of contents shall list unused chapters as "Not Used". Unused chapter numbers and titles shall not be included in the manual or referenced in the text.

3.2.3.2.1 Chapter 00, general equipment description. Chapter 00 shall provide a general description of the equipment and installed systems, as well as applicable safety and protective devices. The general arrangement, principal dimensions, station diagrams (if required), pictorial diagrams (e.g., walkways, access, danger areas, equipment location, cable routing), and any capabilities or limitations peculiar to the equipment (e.g., ambient operating temperatures, relative humidity, operating and nonoperating barometric pressures, wind loading, ice loading, fatigue life calculations) shall be provided. First level equipment block diagrams, with supporting illustrations, shall be used to aid understanding. Associated JG manuals shall not be prepared.

3.2.3.2.2 Chapters 1, 2, 3, and 4, reserved. These chapters are reserved for additional requirements as specified by the acquiring activity (See 6.2d.).

3.2.3.2.3 Chapters 5 and 8. These chapters are for reference only and shall reference the -6 inspection manual (both scheduled and unscheduled), -5 series manuals, and cargo/munitions loading manuals. Electronic media requirement: References shall be linked to the data to which they apply.

3.2.3.2.4 Chapter 6, dimensions and areas, chapter 11 placards and markings. These chapters shall provide the information required by MIL-STD-1808. Associated JG manuals shall not be prepared.

3.2.3.2.5 Chapters 7, 9, 10, and 12. These chapters shall provide the information required by MIL-STD-1808 and shall have associated JG manuals prepared. Electronic media requirement: When references are made to the associated JG manual, these references shall link to the associated manual.

3.2.3.2.6 Chapter 13, equipment storage. The introduction shall explain the purpose of the chapter and shall reference TO 1-1-17 as a source of additional general information, and shall include relevant information needed to use the manual. If the information in TO 1-1-17 is not sufficient, the equipment storage chapter shall contain the information needed to supplement TO 1-1-17. Unless otherwise specified, associated JG manuals shall be prepared (see 6.2e.). Electronic media requirements: When references are made to the associated JG manual, these references shall link to the associated manual. This chapter shall include instructions to process equipment for:

- a. Temporary storage
- b. Extended storage (over 90 days)

**MIL-DTL-83495C (USAF)
W/AMENDMENT 1**

- c. Inspections and treatments during storage
- d. Removal from storage
- e. Procedures for moving or flying a system to an overhaul/maintenance facility

3.2.3.2.6.1 Equipment storage arrangement.

Section I Introduction.

Purpose.

Types of Storage.

General Instructions.

Special Tools and Test Equipment.

Section II Temporary Storage.

Preparation and Securing.

Inspection and Treatment During Storage.

Removal.

Section III Extended Storage.

Preparation and Securing.

Inspection and Treatment During Storage.

Removal.

Moving or Flying System to Another Location.

3.2.3.2.6.1.1 Required storage equipment. Designs or part numbers with sources for material or equipment needed to process the system shall be given. This shall include stands needed to store components in or near a system. A tabular format of special tools and test equipment shall be prepared and listed according to 3.3.5.3.2.1. Electronic media requirements: When the table spans more than one screen, the table shall be formatted as a scrolling table.

3.2.3.2.6.1.2 Temporary storage. The section on temporary storage shall include the location of protective covers and tie-down points. Any other procedures necessary to protect the system during temporary storage shall be given.

3.2.3.2.6.1.3 Extended storage. This section shall contain diagrams of the equipment exterior and instructions which give the following:

- a. Openings that must be sealed from rain and dust.
- b. Location of vent tubes or drain holes.
- c. Location of acrylic windows which need protection from sunlight.
- d. Tie-down points and cable strength.
- e. General location of unpainted metal surfaces which need protection.
- f. Location of fuselage drain plugs on amphibious aircraft shall be shown or referenced.
- g. The type preservative or protection required.

3.2.3.2.7 Chapter 15, support equipment. This chapter shall contain specialized Support Equipment (SE) information required to maintain or to test the equipment or systems. Common or standard SE shall not be included. When specified, associated JG manuals shall be prepared (see 6.2f.). Electronic media requirements: When references are made to the associated JG manual, these references shall link to the associated manual.

3.2.3.2.8 Chapter 16, siting installation. When specified, (see 6.2g.) this chapter shall provide installation data, in the form of text, illustrations, tables, and charts for equipment (e.g., ground CE) and shall be divided into the following sections:

**MIL-DTL-83495C (USAF)
W/AMENDMENT 1**

Section I Installation Logistics.

Section II Installation Procedures.

3.2.3.2.8.1 Section I, installation logistics. This section shall contain information relative to unloading, unpacking, housing, and storage of equipment prior to and during installation.

3.2.3.2.8.1.1 Unloading and unpacking. Unloading instructions shall include tie-down cable removal, strapping or blocking, and equipment securing procedures with illustrations. All precautions to be observed when removing equipment from shipping devices shall be provided. If necessary, procedures to remove the equipment and accessories packaging shall be stated. Storage and accountability of reusable equipment, covers, protectors, cases, special containers, etc., shall be included.

3.2.3.2.8.1.2 Required equipment list. Crated and uncrated dimensions and weights of equipment and parts shall be indicated. Where applicable, the purpose and a brief description of each major group, e.g., antenna group, shall be provided. A table shall list all the supplied assemblies, components, units, cables, etc., by official nomenclature (if such exists) and common names. The listing shall include mounting hardware, gaskets, shims, air duct hoods, fittings, cabinet hardware, etc. A list of equipment required, but not supplied by the contractor, shall be included. Equipment required for service or installation of the equipment shall be identified by the manufacturer, including Government Furnished Property (GFP). Electronic Media requirements: If the table spans more than one screen the table shall be formatted as a scrolling screen.

3.2.3.2.8.1.3 Material handling equipment. Equipment required to transport, handle, and aid in the installation shall be identified.

3.2.3.2.8.1.4 Cables. A table listing of interconnecting power and remote control cable assemblies, shall be prepared, as required. Instructions shall include the fabrication of cable assemblies not supplied, critical cable lengths, and technical characteristics. Electronic media requirement: If the table spans more than one screen the table shall be formatted as a scrolling table.

3.2.3.2.8.2 Section II, installation procedures. This section shall contain installation requirements to ensure operational performance. Man-hours and manpower requirements shall be listed for all phases of the installation, if variables exist. Installation procedures and sequencing shall be sufficient for field installation.

3.2.3.2.8.2.1 Installation requirements. Information required to support the equipment installation, e.g., antenna towers and radomes, including a table showing guying tension in pounds, sag, vibration limits at various ambient temperatures, etc., shall be provided. Electronic media requirements: If the table spans more than one screen the table shall be formatted as a scrolling table.

3.2.3.2.8.2.2 Installation sequence. Step-by-step procedures required to accomplish assembly, installation, and interconnection of equipment parts shall be stated. Illustrations shall be included, as required. Procedures shall be divided into applicable headings, e.g., power generating equipment, antenna and waveguide (or antenna cables) systems, transmitters, receivers.

3.2.3.2.9 Chapter 17, preparation for use and shipment. When specified (see 6.2h.), this chapter shall provide preparation instructions for use and shipment. Illustrations, tables, and charts, as required, shall be provided. The chapter shall be divided into the following sections:

Section I Preparation for Use.

Section II Preparation for Shipment.

3.2.3.2.9.1 Section I, preparation for use. Tune-up, testing, and adjustment instructions required to make the equipment operational shall be provided. Required illustrations shall be included. Instructions located elsewhere, shall be referenced. Electronic media requirements: References shall be linked to the data to which they apply. This section shall include:

- a. Test descriptions needed to demonstrate all functional requirements.
- b. Procedures to determine performance levels and to record test data.
- c. A sequence list of all tests, including flight and electronic countermeasure testing.

**MIL-DTL-83495C (USAF)
W/AMENDMENT 1**

- d. Test criteria, such as: Performance specification, test interface (cables, plugs, attenuators, etc); test equipment, use of test data sheets, oscilloscope patterns, pen charts, computer readouts, test configuration diagrams etc.

3.2.3.2.9.2 Section II, preparation for shipment. Electronic media requirements: If the table spans more than one screen the table shall be formatted as a scrolling table. This section shall describe and illustrate procedures to prepare the equipment for shipment, and include:

- a. Methods and conditions of shipment.
- b. Special disassembly or dismantling instructions to prepare the equipment for shipment, or a condition or procedure requiring special attention.
- c. Instructions for reuse of shipping cases or containers. A tabular listing, by part number, shall be included for reusable containers and shipping covers.
- d. Removal instructions for special tubes, plug-in units, etc., before shipping, including removal of equipment or parts from mountings. Instructions for building packing crates shall not be included.

3.2.3.2.10 Chapter 18, weapons instrumentation. This chapter shall provide the necessary coverage for airborne weapons used for test, data acquisition and flight termination. It shall encompass all necessary information to accommodate weapon payload and telemetry testing. This chapter shall be used for aircraft in lieu of a "-101" TO. When specified, associated JG manuals shall be prepared (see 6.2i.).

Electronic media requirements: If references are made to the associated JG manuals these references shall link to the associated manual.

3.2.3.2.11 Chapter 19, training equipment. Specialized training equipment shall be included in this chapter. When specified, associated JG manuals shall be prepared (see 6.2j.). Electronic media requirements: If references are made to the associated JG manuals these references shall link to the associated manual.

3.3 General system (GS) manual. Normally, separate GS manuals shall be prepared for each system. Combined GS manuals shall be prepared, depending upon systems complexity, as specified by the acquiring activity (see 6.2k.). Coverage of a specific subsystem shall not be divided between two GS manuals.

Electronic media requirements: Page count restrictions do not apply.

Print media requirements: Multiple manuals shall be prepared when the system coverage exceeds 800 pages (400 sheets).

3.3.1 Scope. The GS manual shall provide detailed system, subsystem, and sub-subsystem description, theory of operation, software interface, emergency operation, tolerances, special procedures, and maintenance support information not suitable for JG manuals. It shall reflect purpose, type, main features, and supporting data for the system being covered. If the equipment is an integral part of a functional end item, it shall explain how the equipment functions within the end item.

3.3.1.1 Classified material. When a classified supplemental GS manual is prepared, the scope of the manual shall be expanded to include classified information not normally pertinent to a GS manual, e.g., testing, fault isolation, etc. Classified information provided shall pertain only to the system(s) of the basic manual.

3.3.2 Numbering. Chapters, paragraphs, figures, and tables shall be numbered in accordance with MIL-STD-38784, except the SSSN shall form a part of the paragraph heading. Each manual shall be divided into chapters as defined in 3.3.5.

Print media requirements: All pages shall be numbered in accordance with MIL-STD-38784.

3.3.3 Size. Electronic media requirements: Page size requirements do not apply.

Print media requirements: The GS manuals shall be prepared in the standard 8½ by 11 inch size.

3.3.4 Systems covered. The system(s) covered shall be identified by government assigned titles. System subsystem subject numbers (SSSN) shall be in accordance with MIL-STD-1808.

3.3.5 General systems arrangement. Electronic media requirements: The book shall be chunked by chapters. The GS manuals shall be arranged in the following manner:

**MIL-DTL-83495C (USAF)
W/AMENDMENT 1**

Front Matter.

Chapter 1 Theory of Operation.

Chapter 2 Special Tools, Test Equipment, and Consumables.

Chapter 3 System Peculiar Maintenance.

3.3.5.1 Combined GS manual. Each chapter shall have three sections, as follows.

Front Matter.

Chapter 1 (System 23).

Section I Theory of Operation.

Section II Special Tools, Test Equipment and Consumables.

Section III System Peculiar Maintenance.

Chapter 2 (System 24).

Section I Theory of Operation.

Section II Special Tools, Test Equipment and Consumables.

Section III System Peculiar Maintenance.

In combined manuals, Chapter 1, Chapter 2, etc., shall be used to include each system, e.g., Chapter 1 (System 23), Chapter 2 (System 24), etc. (The systems covered and the method of how chapters and sections are set up shall be explained in the foreword of each manual).

Electronic media requirements: In a combined manual the book shall be chunked by section instead of just chapters.

3.3.5.2 Front matter. Front matter shall be prepared in accordance with MIL-STD-38784 and applicable requirements specified herein (see 3.1).

3.3.5.2.1 Foreword. The foreword shall provide an explanation of the manual's scope and arrangement, including any relevant information, e.g., Computer Program Identification Number (CPIN) list by number and title, in table format.

3.3.5.3 Chapters.

3.3.5.3.1 Chapter 1, theory of operation. Chapter 1 shall provide system/subsystem overall functional description and general information, as required. Theory of operation shall be based on the functional flows within the system to a level compatible with level one schematics (see MIL-HDBK-863). Level one, two, and three schematics shall be used, as necessary, to support the system description. Illustrations showing the appropriate locations of all Line Replaceable Units (LRU) shall be provided.

Electronic media requirements: References shall be linked to the data to which it applies.

Print media requirements: Appropriate references to the diagrams shall be included.

3.3.5.3.2 Chapter 2, special tools, test equipment and consumables. This chapter shall list and illustrate the special tools, test equipment, and consumables required for all system functional tasks. Standard tools and test equipment shall not be illustrated. Such items shall be selected from the list of tools and test equipment approved by the Government by means of SE listings, provisioning processes, engineering changes, procurement documents, etc. Standard tools, such as screwdrivers and pliers shall not be listed. Standard test equipment, such as voltmeters and oscilloscopes shall be listed. When a contractor cannot obtain an approved list, the contractor's recommended special tools and test equipment shall be shown and promptly updated to conform to the official Government list.

**MIL-DTL-83495C (USAF)
W/AMENDMENT 1**

3.3.5.3.2.1 Special tools and test equipment list. When specified, illustrations of peculiar equipment shall follow the table listing special tools/support equipment (see 6.21.).

The table shall be formatted as follows:

SPECIAL TOOLS AND TEST EQUIPMENT

Item	Nomenclature	Part Number/ Type Designation	CAGE Code	Figure and Index Number
------	--------------	----------------------------------	-----------	----------------------------

- a. Item. Consecutive numbers shall be used for individual items.
- b. Nomenclature. Nomenclature shall be in accordance with the requirements of MILSTD- 38784.
- c. Part number/Type Designation. Special tools and test equipment shall be listed in alphanumeric sequence by part number/type designation. If alternate or suitable substitutes may not be used, footnotes to the table shall so state.
- d. CAGE Code. The Commercial and Government Entity (CAGE) Code or manufacturer's name and address if no CAGE Code is assigned.
- e. Figure and index number. The figure and index number shall be shown.

Electronic media requirements: If the table spans more than a screen it shall be formatted as a scrolling table.

3.3.5.3.2.2 List of consumable materials. Consumable materials and expendable items shall be listed. All chemicals shall be grouped separately at the beginning of the list.

The list shall be in tabular format, in alphabetical order by nomenclature, as follows.

LIST OF CONSUMABLE MATERIALS

Item	Nomenclature	Specification/PN	CAGE Code	Use	Reference
------	--------------	------------------	-----------	-----	-----------

- a. Item. Consecutive numbers shall be used for individual items.
- b. Nomenclature. Nomenclature shall be in accordance with the engineering drawing title block and MIL-STD-38784.
- c. Specification / PN. The military, Government, commercial specification number or part number shall be shown.
- d. CAGE code. The CAGE Code or manufacturer's name and address shall be used if a CAGE Code has not been assigned.
- e. Use. The purpose and primary use of each item shall be included.
- f. Reference. Reference where each item will be used.

Electronic media requirements: If the table spans more than a screen it shall be formatted as a scrolling table.

3.3.5.3.3 Chapter 3, system peculiar maintenance. This chapter shall contain system peculiar maintenance that does not lend itself to JG format, e.g., structural crack limitations.

3.4 JG manual. JG manuals shall provide complete detailed procedures for on equipment maintenance. These procedures shall be organized into a series of publications with a separate manual, or manuals, for each major system. Separate manuals may be prepared for a subsystem(s) when necessary due to equipment complexity. SSSN breakouts shall be in accordance with MIL-STD-1808.

3.4.1 Scope. The JG manual shall provide detailed start-to-finish, step-by-step, maintenance instructions. Each procedure shall be arranged in logical sequence. Instructions shall be fully illustrated to support the text. Instructions shall cover removal, installation, alignment (electrical and mechanical), adjustment, calibration, operational checkout, and other maintenance procedures as applicable, including operation of special equipment.

3.4.2 General requirements.

**MIL-DTL-83495C (USAF)
W/AMENDMENT 1**

3.4.2.1 Style of writing. The material shall be factual, specific, concise, and clearly worded. Use of common names shall conform to the requirements of 3.1.2.1. Emphasis shall be placed on steps to be followed.

3.4.2.1.1 Syntax. Normal sentence structure (subject, verb, object) shall be used for narrative text. Task steps shall be written in the second person imperative (see a., below). Modifiers, if required, shall be used to define equipment location and method or direction of manipulation. When a special tool is called out as a part of a step, the word "using" and the tool name shall precede the statement (see b., below). The third person indicative mood or second person imperative mood, whichever is more effective, shall be used for description and discussion statements such as Warnings, Cautions, and Notes. Task step numbers shall be keyed to the illustration (see 3.4.2.2) to minimize the need for complex sentence structure and modifiers (adjectives and adverbs).

Examples:

- a. "1. Set switch to ON."
(The switch and location are identified as callout "1" on the accompanying illustration.)
- b. "3. Using snap-ring pliers, remove retainer clip."
(The special tool identifier is added.)

3.4.2.2 Format. Electronic media requirement: Text information shall be presented in one pane/window with the related illustration in a separate pane/window at the same time. Function and task title shall not be underlined.

Print media requirements: Text information in 5 by 8 inch manuals shall be presented on the left-hand page and the related illustration on the right-hand page. Text information for standard size 8½ by 11 inch manuals shall be presented in double column format with textual information located at the top half of the page and the related illustration on the bottom.

3.4.2.3 Numbering. Chapters shall be numbered within a JG manual(s) covering a specific subsystem and shall be sub-subsystem oriented. Functions shall be consecutively numbered within a chapter. Tasks shall be consecutively numbered within functions, e.g., the fourth task, in the second function, in chapter three, would be 3-2-4. Each numerical identifier shall be separated by a dash. Steps shall be consecutively numbered within a task, e.g., task 6-11-10 might have eight steps numbered 1 through 8.

3.4.2.4 Size. Print media requirement only: JG manuals shall be prepared in either 5 by 8 inch pocket size, or 8½ by 11 inch standard size, as specified by the acquiring activity (see 6.2m.). Pocket size JG manuals shall be limited to 400 pages (200 sheets). Standard size JG manuals shall be limited to 800 pages (400 sheets). If the proposed JG manual exceeds these page limitations, it shall be divided at lowest level nearest the complete function. Tasks shall not be divided unless absolutely necessary. The contractors recommended breakout shall be approved by the acquiring activity on a case by case basis.

3.4.2.5 Nomenclature. Consistency shall be maintained between the first usage of nomenclature in the text of each task and illustration callouts on the first reference of an equipment item (see 6.2n.). The higher level designator (HLD) shall follow the first usage nomenclature, if required (see 6.2).

3.4.2.6 Tolerances. Information on how the equipment must respond, either in numerical or qualitative terms shall be provided. Clearances, flow rates, pressures, nonstandard and critical torque values, voltage, frequency, amperage, resistance, or other measures shall be provided, with applicable tolerances. Measurements shall be given in the units of the tool(s) or equipment required. If general instructions for installation of standard hardware must be given, it shall provide complete instructions in the task step, e.g., "Install panel screws and tighten so that screw heads are flush with the panel and the panel is flush with surrounding surfaces." Use of general instructions within JG tasks shall held to an absolute minimum.

3.4.2.7 Foldouts. Print media requirements: Foldout pages shall only be used for tables and illustrations as approved by the acquiring activity (see 6.2o.). Tables or illustrations may be rotated 90 degrees counterclockwise to preclude the use of foldouts. When used, foldout pages shall be interspersed throughout the manual. Turn-pages (text on back) shall not be used.

3.4.2.7.1 Blank aprons. Print media requirements: Foldouts used in JG manuals shall not have blank aprons if they support a single page task and shall be located opposite the task instruction. Foldouts supporting multi-page tasks shall have blank aprons and shall be located on the right-hand page following

**MIL-DTL-83495C (USAF)
W/AMENDMENT 1**

the last text page supported. Use of foldouts to support a single page task shall be approved by the acquiring activity (see 6.2).

3.4.2.8 Cross reference. The JG manual(s) shall contain a minimum of cross references to other than those procedures or tasks within the same section or subsystem. Cross referencing within the section or subsystem may be made when the reference applies to a complete task.

Electronic media requirements: Cross references shall be made by electronic links.

3.4.3 Arrangement. The basic contents of the JG manual and its arrangement shall be as follows:

Front Matter

Chapter 1 General Instructions (system peculiar).

Chapter 2 and subsequent Chapters (system maintenance instructions).

3.4.3.1 Front matter. JG manuals front matter shall be prepared in accordance with MIL-STD 38784, and applicable requirements specified herein (see 3.1), except no List of Illustrations or List of Tables is required. Front matter shall consist of the following:

3.4.3.1.1 Table of contents. Table of contents shall list each Line Replaceable Unit (LRU) or item covered, each function and task for the listed LRU or item, and shall cross-reference the applicable SSSN (if a function consists of only one task, only the function shall be listed). Each manual of a multi-manual set shall contain a cross-reference listing of the functions in all other manuals in that series. Tasks shall be listed only in the JG manual in which they exist (see figure 2).

Electronic media requirements: Table of contents shall be linked to the text to which they apply.

3.4.3.1.2 Foreword. The foreword shall be prepared in accordance with MIL-STD-38784. In multimanual JGs, only the first manual shall contain the foreword. Notes explaining the applicability of a system shall be used, e.g., "This is applicable to F-16C aircraft." When required, the following note pertaining to CPIN shall be added to the foreword of the JG manual: "NOTE: Refer to the applicable CPIN compendium to verify the latest version/revision of any computer program configuration item (CPCI) required to perform operational checkouts, automatic testing features, etc."

3.4.3.1.3 Safety summary. The safety summary shall be prepared in accordance with MIL-STD-38784. In multi-manual JGs, only the first manual shall contain the safety summary. In 5 by 8 inch JGs, the safety summary shall be the last primary paragraph in the foreword.

3.4.3.2 Chapters. Chapter one shall provide system peculiar information, e.g., specific torque wrench usage, lockwire procedures, "O" ring seal installation, and leakage rates. Subsequent chapters shall contain information applicable to specific subsystems or parts of the system. Chapter numbering shall continue through the entire system JG, e.g., XXJG-00-1 has chapter 1, XXJG-10-1 has chapter 2, etc.

3.4.3.2.1 Functions. A maintenance function consists of input conditions, a task or series of tasks, and supporting illustrations (see 6.2p.). Tasks shall be related in nature to the function, e.g., "all tasks supporting the installation of an engine shall relate to and support the installation process and use the same input conditions". Functions shall not be combined unless supported by the same input conditions. An example of a combined function might be "remove and install amplifier". Combined functions shall not include any subtasks. When typical maintenance functions are used, the task function within shall be arranged in the following sequence.

- a. Operational checkout. Location data for all end-items affected by the check and the primary equipment required for complete testing of the system shall be included. Normal indications (shown as "dot" results) shall be provided as well as appropriate fault codes, when applicable, e.g., " • MASTER CAUTION light goes out. (33-10-XJ)"
- b. Access. All operations necessary to gain access to an item or to remove equipment blocking accessibility to that item shall be provided. Access panels, screws, and fasteners of different sizes within the same panel shall be identified.
- c. Remove. All hardware items to be removed shall be specified by name. Instructions shall be included for matching, marking, or labeling for reinstallation of any part which could be installed incorrectly, including: Cables, hoses, or lines which are disconnected during removal; special

**MIL-DTL-83495C (USAF)
W/AMENDMENT 1**

- hardware items (nonstandard fasteners, brackets, or fittings slightly different from others in the same assembly). Characteristics (longer, thicker, plastic, etc.) shall also appear as a callout on the illustration. Instructions shall be included to retain items for reinstallation and to record the position of items removed, such as the number of shims at each attaching point.
- d. Repair. Instructions shall cover repair or replacement of items, e.g., hoses, desiccants, special connectors, clamps, etc.
 - e. Install. All hardware items to be installed shall be specified by applicable nomenclature (see 3.4.2.5). Instructions shall refer to any items retained during removal and to the item's position before removal. No steps shall be included to install an item that must be removed in an immediately performed, subsequent function, task, or follow-on procedure.
 - f. Rigging. Procedures and illustrations for rigging shall be provided, e.g., flight controls, engine throttles etc.
 - g. Inspection. Methods, equipment, and instructions for complete inspection shall be provided. Allowable service limits and adequate standards for determining appropriate maintenance action shall be stated. Required testing of assemblies or subassemblies shall be included. Inspections covered by manuals such as nondestructive inspections, corrosion control, structural repair, etc., shall not be included.
 - h. Cleaning. Special cleaning requirements shall be described, including the nomenclature and specifications of cleaning agents.
 - i. Lubrication type, amount, method of application, and the specification of the lubricant shall be stated. Lubrication points shall be illustrated and identified. The requirements of MIL-HDBK-275 are applicable. Only the lubrication required as a result of the maintenance performed shall be included.
 - j. Servicing. Procedures shall be provided to check, replenish or remove fuel, oil, hydraulic fluid, other fluids, oxygen, tire pressure, and all items involved in completely servicing/deservicing equipment, except scheduled equipment lubrication. Tank and reservoir capacities, and specifications and grades shall be shown.
 - k. Jacking. Procedures shall include diagrams showing the location of jack points, jack types, and specific methods to be used. Instructions shall be included for hoisting the equipment, e.g., missile stages, trailers, antennae, etc. Use of slings and procedures for maintaining correct balance of hoisted items shall be provided, including location of leveling legs, reference points, and access points.
 - l. Alignment and Adjustment. Procedures shall be provided for alignment and adjustment following the replacement of parts or assemblies, or as required to ensure the part or equipment meets operational performance standards.
 - m. Calibration. Procedures shall be provided to accomplish recurring on-equipment accuracy checks or adjustments.
- 3.4.3.2.1.1 Input conditions. The input conditions (see figure 1) shall provide all the necessary information needed prior to performing the function. Unused headings shall be listed as "none" or "not applicable," as appropriate. Optional headings shall not be listed if not used. The following items shall be included in the input conditions, in the order described.
- 3.4.3.2.1.1.1 Applicability. Applicability (see 3.1.7) codes shall be provided. If the instructions apply to all equipment, the word "All" shall be used. Statements which explain applicability for individual items of equipment shall use either serial number range, block designation, or similar identification. Such terms as "on later equipment" and "on early serial numbers" shall not be used.
- 3.4.3.2.1.1.2 Required conditions. When required conditions must be obtained by performing other organizational maintenance instructions, these instructions shall be indicated as prerequisite to the task, e.g., "Aircraft safe for maintenance (JG 10-30-01)."

**MIL-DTL-83495C (USAF)
W/AMENDMENT 1**

3.4.3.2.1.1.3 Personnel recommended. The minimum number of personnel required to effectively perform the maintenance shall be provided. Location and duties for multi-person requirements shall be identified at the beginning of the function. When a team is required, members of the team shall be identified at the beginning of the procedure. For example:

Personnel Recommended: Four

Technician A: Supervise operations.

Technician B: Connect and disconnect equipment.

Technician C: Operate equipment.

Technician D: Inspector

3.4.3.2.1.1.3.1 Multi-person requirements. Multi-person requirements shall be included as identified in the supportability analysis. Assistants shall be identified when required (see 6.4.16). The responsible technician shall be associated with the applicable action or observation. Steps shall be presented in the sequence to be performed. A notation shall precede each step indicating which member of the team will perform the step. For example:

(A) Position....

(B) Insert....

(B and C) Raise and install....

(D) Inspect clearance....

(A) Turn power switch to....

3.4.3.2.1.1.4 Support equipment. The government approved support equipment (test equipment, special tools, and ground handling equipment) shall be identified. Common types of tools normally found in the technician's tool kit shall not be listed. Common types of test equipment such as, voltmeters, signal generators, etc., shall be listed. Equipment shall be listed by nomenclature and Joint Type Electronics Designation System (JTEDS), assigned Aeronautical Equipment Identification Designators (AN/AEID), or the commercial or manufacturers designation if the JTEDS or AN/AEID types are not assigned. Quantity required shall be shown. When applicable, equipment capacity, range, etc., shall also be included. If alternate equipment can be used, the term "or equivalent" shall follow the nomenclature.

3.4.3.2.1.1.5 Consumables. Consumable and expendable items required to perform all the tasks within that function shall be listed in accordance with 3.3.5.3.2.2. (see fig 2.2)

3.4.3.2.1.1.6 Safety conditions. Pertinent safety information shall be included as prescribed in MIL-STD-38784.

3.4.3.2.1.1.7 Checklist requirements (Optional). One of the following requirements shall be used when the function is designated a checklist, as specified by the acquiring activity: (see 6.2q.)

- a. A lead-in-statement shall be provided to indicate that the function shall be followed in exact step-by-step checklist sequence to prevent damage to equipment or injury to personnel.
- b. The primary procedural steps shall be prepared in bold face type. Within a secondary procedural step, bold face type may be used on portions with checklist value. A lead-in statement shall be provided in the manual proceeding the function/task explaining the use of bold face type.

3.4.3.2.1.1.8 Additional data. All other technical data required to reference in the functions shall be listed under this heading. The information required by 3.4.3.2.1.1.2 (Required Conditions) shall not be combined with additional data.

**MIL-DTL-83495C (USAF)
W/AMENDMENT 1**

3.4.3.2.1.2 Tasks. All tasks within a function shall relate to that function (see figure 4). Procedural steps that do not establish item location shall not be supported by illustrated details, e.g., "measure and record ambient temperature".

Print media requirements: Tasks shall begin on a left hand page (see figure 3).

3.4.3.2.1.2.1 Text. The following guidance is provided for special situations:

- a. Instructions of a specific nature for installation of standard hardware shall be provided if required.
- b. If a typical set of instructions is prepared, the function shall be identified as "typical". The equipment to which the typical function applies shall be identified, e.g., left and right side mounted main landing gear actuator valves, hydraulic pump removal (typical).
- c. When required, a repeated task or sequence of tasks shall be provided in detail and shall not contain circular references to previous steps or procedures in the same task, other tasks, or other publications. For repeated sequences, instructions shall be provided for repeating the applicable task and action to take when the repeated sequence is completed.
- d. Print media requirements: A multi-page task such as operation, checkout, adjustment, lubrication, etc., that must be supported by a foldout illustration, shall begin on a left-hand page and page continue on the right and left-hand pages as necessary to conclude the task.
 1. If required, repeated task shall be used when the following conditions are met:
 - (a) The task does not involve danger to the technician or equipment.
 - (b) The sequence of steps within the task is exactly the same.
 - (c) Not more than two tasks intervene between the first and subsequent use of the task.
 - (d) No dimensional tolerance information is required.
 2. Repeated sequence of tasks shall be used, as required, when the following conditions are met:
 - (a) Two or more tasks are repeated in sequence.
 - (b) Reference information used applies to each repeat.
 - (c) Tasks are identical for different but related control or display.
- e. Special instructions shall follow the appropriate task step. For example:

ADJUSTMENT OF ANTENNA GUY CABLE

7. Safety wire left-hand turnbuckle.
SPECIAL INSTRUCTION. Using 0.032 safety wire, safety wire turnbuckle to ensure force is applied in a direction that maintains cable tension.

14. Safety wire right-hand turnbuckle.
SPECIAL INSTRUCTION. Using 0.032 safety wire, safety wire turnbuckle to ensure force is applied in a direction that maintains cable tension.

3.4.3.2.1.2.2 Follow-on maintenance. References to applicable JG manual(s) shall be provided under this heading for instructions on returning the equipment to the required condition (see 6.4).

Electronic media requirements: References to JG manuals shall include linking capability, where possible.

Print media requirements: To conserve space follow on maintenance reference information may be listed on the same page and immediately following the last task text, space permitting.

3.4.3.2.1.3 Illustrations. Illustrations shall convey location and, if applicable, dimensional data with tolerance information (see fig 10). Illustrations shall be applicable only to the tasks being performed, plus sufficient surrounding detail to allow a technician to locate the equipment. The level of detail shall progress from general to specific on each illustration. For example: A general locator detail shall precede a view which relates the specific LRU location to overall end item. Line drawings shall be used. Switches, knobs, controls,

**MIL-DTL-83495C (USAF)
W/AMENDMENT 1**

etc., shall be shown in the normal or off position. Appropriate details shall be indicated using callouts with identification numbers keyed to the task step number directing the action, e.g., callout number 1 and the first task step shall correspond, callout number 2 and the second step shall correspond, etc. Callouts used on the illustration for clarification shall not be keyed to the text. Multiple key identification numbers shall be used when the callout is applicable to more than one step. Leader lines or sweep arrows shall be used to help the reader orient themselves with respect to the illustration. Leader lines shall be used to connect callouts and identification numbers. When an equipment item is first called out in a task, and its location has not yet been specified, a general location illustration shall be used to identify the position of the item within the system. In addition, the following shall be followed for the specific situations indicated: Illustrations which apply to more than one component or sub-subsystem shall be identified by the word "TYPICAL" placed near the bottom center of the illustration. Figure numbers shall not be used for JG task illustrations.

Electronic media requirements: The task title shall have some linking method to bring up the appropriate graphic associated with that task.

Print media requirements:

- a. Two tasks using the same illustration shall be included on the same page if both can be included without crowding. Index numbers for the second task shall be suffixed with the letter "A" and subsequent.
- b. If the associated illustration occupies less than its allotted space, textual information shall be continued on the top right-hand page, without crowding.
- c. Illustrations shall be rotated 90 degrees counterclockwise to preclude the use of a foldout page or to be compatible with rotated text.
- d. Illustrations for multi-page tasks shall be held to a minimum. Illustrations supporting multi-page tasks, when required, shall be located on a right-hand foldout page at the end of the task and shall have a blank apron.

3.4.4 JG index manual. The applicable SSSN shall be provided in parenthesis following each system, subsystem, sub-subsystem, equipment nomenclature, or item listed (e.g., Title (SSSN); JG Number; Chapter). This manual shall be numbered as the first JG manual, e.g., 1F-1A-2-00JG-00-1. This manual shall contain an alphabetical listing of all systems, subsystems, sub-subsystems, equipment nomenclatures, and items covered in the JG manual set. The listing shall cross-reference the applicable JG number and chapter number.

Electronic media requirement: Alphabetical listing for all systems should have linking capabilities to JG and chapter where possible.

3.5 Fault reporting (FR) and fault isolation (FI) manuals. These manuals shall provide equipment fault isolation and fault reporting information, and are to be used in conjunction with each other. FI and FR manuals shall be updated or revised concurrently. Combined manuals shall be prepared if specified by the acquiring activity (see 6.2r).

Electronic media requirements: Page count requirements do not apply.

Print media requirements: Combined manuals shall not exceed 800 page units (including foldouts).

3.5.1 Scope. The FR manual shall identify detailed equipment malfunctions. The FI manual shall provide the fault analysis and identify the corrective action(s) for malfunctions listed in the FR manual. Fault isolation information shall be provided for any fault which requires troubleshooting, including maintenance observable faults while the equipment is in operation. Specific fault codes shall be assigned to those malfunctions identified through the supportability failure modes analysis.

3.5.2 General requirements.

3.5.2.1 Manual form. Electronic media requirements: Page size requirements do not apply.

Print media requirements: Page size shall be 8½ x 11 inches. Presentations shall be vertical on the page. FI manual schematics shall be horizontal, when required.

3.5.2.2 FR manual numbering. The chapter number and title shall be the system number and title from MIL-STD-1808.

**MIL-DTL-83495C (USAF)
W/AMENDMENT 1**

Electronic media requirements: The system title shall be placed in an area that will allow it to be persistently visible.

Print media requirements: The system title shall appear in the lower outside margin.

3.5.2.3 FI manual numbering. The chapter number and title shall be the system number and title from MIL-STD-1808. Section numbers and titles (when used) shall be subsystem oriented. When prepared as separate manuals by system, the chapters shall be sectionalize by subsystem.

Electronic media requirements: The SSSN shall be placed in an area that will allow it to be persistently visible.

Print media requirements: The SSSN shall appear in the lower outside margin.

3.5.2.4 Nomenclatures and abbreviations. Terms used shall be consistent between the FI and FR manuals and have only one meaning.

3.5.3 Content and arrangement. The FR and FI manuals shall contain the following information in the order shown.

- a. Fault Reporting Manual. (see fig 4.)
 - Front Matter.
 - Chapters.
 - Table of Contents.
 - Fault Identification.
 - Log Book Report. (see fig 8.)
- b. Fault Isolation Manual. (see fig 5.)
 - Front Matter.
 - Chapters.
 - Table of Contents.
 - Fault Identification.
 - Log Book Report.
 - Location of Parts.
 - Fault Isolation Information.
 - Supplemental Data.

3.5.4 Front matter. The front matter for both the FR and FI manuals shall be in accordance with MIL-STD-38784, except as specified herein (also see 3.1).

- a. The table of contents shall consist of only chapter numbers and titles.
- b. An alphabetical index shall be provided at the end. The alphabetical index shall consist of all systems and subsystems covered. The subject listings for the FR and FI indexes shall be identical, however, the FR index shall refer to FR chapter numbers and the FI index shall refer to chapter and section numbers.
- c. The method used to locate information for specific equipment shall be explained in the foreword.

Electronic media requirements: The table of contents shall link to the data to which it applies. A search capability may replace the need for an alphabetical index, but if used, the entries shall link to the data to which they apply.

3.5.5 Chapters. Electronic media requirements: Books shall be chunked at the section and fault description levels.

3.5.5.1 Chapter table of contents. Each FR and FI chapter shall contain an illustrated alphabetical table of contents (figures 4 and 5). Instrument panel indications shall be shown as an exploded view, in relation to the next higher assembly.

Electronic media requirements: The FR and FI manual's table of contents shall be linked to the data to which it applies. The FR manual shall not refer to page numbers. The chapter table of contents shall appear

**MIL-DTL-83495C (USAF)
W/AMENDMENT 1**

at the beginning of each chapter as a separate chunk. The illustration shall include pertinent instrument panel indications using leaderlines with arrowheads to associate the chapter SSSN (FI manuals) (see 6.2s.).

Print media requirements: The illustration shall include pertinent instrument panel indications using leaderlines with arrowheads to associate the appropriate page (FR manuals) or chapter SSSN (FI manuals). The FR manual table of contents shall refer to chapter page numbers. The FI manual table of contents shall refer to SSSNs or page numbers as required, e.g. single manual: SSSNs; system oriented manuals: Page numbers. The table of contents shall not exceed two pages unless approved by the acquiring activity (see 6.2).

3.5.5.2 Fault Identification. The format shall be in accordance with the requirements listed below (see figures 6 and 7).

3.5.5.2.1 Procedural guidelines. The procedures designed for fault identification and diagnosis shall be consistent with the following:

- a. Safety shall not be degraded.
- b. Workloads shall not be appreciably increased as a result of using the procedures.
- c. Fault identification shall be limited to single faults.
- d. Minimum assumptions shall be that the operating system was in the normal operating mode prior to fault indication, relevant Circuit Breakers (CBs) were in the normal operating position and checked, and applicable operating procedures were properly accomplished.

3.5.5.2.2 Depth of coverage.

3.5.5.2.3 Illustrated panel indicators. Pertinent panel indicators shall be shown with a listing of CBs and fault location codes at the top of the first system/subsystem fault reporting and fault isolation sheet. Print only requirement: Applicable displays shall be repeated on subsequent fault reporting pages as required. Electronic media requirement: Applicable displays shall be included as required following the fault reporting information.

3.5.5.2.3.1 Panel indicators. Only the indicators associated with the fault listed shall be shown. Each indicator shall be identified by a number correlating with an identically numbered "fault group". In cases where no panel indications exist, the fault group may be established by other means. These groups shall be identified by an unnumbered title, e.g., "No Start".

3.5.5.2.3.2 Circuit breaker listing. Only CBs associated with the particular fault and accessible by operating personnel shall be listed. The HLD of CBs applicable to a test shall be listed after the fault statement, e.g., "Fail Light On (2160CB0021 and 2160CB0023)". In cases where the same CBs apply to all the faults within a fault group, the CBs may be listed after the fault group title instead of after each fault.

Electronic media requirements: CBs shall be identified by name HLD or location, in the upper right hand corner of the chunk adjacent to the Fault Location block.

Print media requirement: CBs shall be identified by name, HLD or location in the upper right-hand corner of the page adjacent to the "fault location block".

3.5.5.2.3.2.1 Additional circuit breaker listing. In addition to 3.5.5.2.3.2, a list of all equipment CBs in the electrical power section shall follow the chapter table of contents. These CBs shall be alphabetically grouped by system. Each CB shall show name, location, and bus.

3.5.5.2.3.3 Fault location codes. In cases where a location code is not required for a particular fault, the "Not Applicable" code "00" shall be used.

Electronic media requirements: Fault location codes shall be in the upper right corner of the chunk.

Print media requirements: Fault location codes shall be listed in the upper right corner of the page.

3.5.5.2.4 Fault groups. Fault groups shall list individual faults in "flow chart" format. Action instruction shall be contained within a block and the monitored result outside the block. An initial status shall be provided for each fault.

3.5.5.2.4.1 Specific fault codes. A specific code for each basic fault, subfault, and single entry fault shall be provided.

3.5.5.2.4.2 Special notations. Special notations shall be presented as notes and shall contain:

**MIL-DTL-83495C (USAF)
W/AMENDMENT 1**

- a. Additional information to be recorded to complete the analysis.
- b. Unusual conditions causing fault recognition and isolation.
- c. Minor configuration differences.

3.5.5.2.4.3 Operating limits. Operating limits shall be given, where possible, the words "normal" or "OK/Not OK," and nominal values shall be given, as required.

3.5.5.2.4.4 Fault codes. The code shall be 8 digits, alphanumeric as follows:

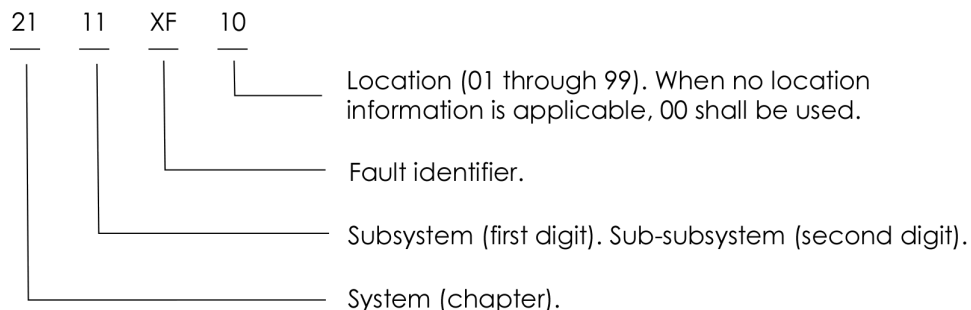

3.5.5.2.4.4.1 Alpha identifier. A two-letter alpha identifier shall be assigned so that the initial letter is the same for a basic fault and each of its related subfaults. The letters "A," "B," and "C" shall be reserved for exclusive use as the second letter for a basic fault. The letters "X," "Y," and "Z" shall be reserved for exclusive use as the first letter for a single entry fault. The letters "OO" shall be used for faults not listed. The letter "I" (eye) shall not be used.

3.5.5.2.4.4.2 Subsystem and sub-subsystems. The third and fourth digit shall follow MIL-STD-1808. To prevent duplication, if interfacing between two or more sub or sub-subsystems, information shall be combined under one subsystem number. Cross-referencing shall be shown in either the pictorial alphabetical table of contents or in the fault reporting material. In addition, the following requirements shall apply:

- a. When fault reporting material is revised, the alpha fault designators may be extended or canceled, but once canceled may not be reused for another fault.
- b. It is not essential for the fault designators to appear in alphabetical order.

3.5.5.3 Log book reports. When specified (see 6.2t.), the FI manual shall duplicate the log book reports contained in the FR manual. The FR manual shall contain complete word descriptions of all coded faults. The reports shall appear at the end of the system/subsystem fault reporting information (see figures 8 and 9).

3.5.5.4 Location of parts. Parts shall be illustrated in fault isolation procedures and shall be shown relative to known equipment features (see figure 11). Parts shown on related schematics which are not called out in the fault isolation procedure shall:

- a. Not be required where location is obvious or becomes obvious as a result of gaining access.
- b. Be shown in the primary subsystem. A reference shall be provided if required.
- c. Provide location information, not to exceed two illustrations for each subsystem.
- d. Be illustrated as line drawings.
- e. List all related CBs or fuses for a particular sub or sub-subsystem at the beginning of the parts location information. CB number, name and location shall be shown.
- f. Print media requirement: Several drawings shall be included per page provided clarity is maintained.

3.5.5.5 Fault isolation information. The FI manual shall contain fault isolation (troubleshooting) procedures which immediately follow the parts location information (see figure 10).

3.5.5.5.1 Sequence. Isolation procedures shall be provided for each coded fault in alphabetical sequence (except as in 3.5.5.2.4.4.2). One isolation procedure shall be used for several coded faults, when applicable.

**MIL-DTL-83495C (USAF)
W/AMENDMENT 1**

3.5.5.5.2 Fault code location. The fault code shall appear in the left cell of the chart. The first code shall be in the upper left corner. Where the isolation procedure applies to more than one code, all codes shall be shown.

3.5.5.5.3 Initial results. Results from the fault isolation procedure shall be shown in the same as the fault code. Additional fault isolation steps and corrective actions shall be placed on subsequent (pages) as required.

Electronic media requirement: The word “page” shall be synonymous with a web page chunk. ■

3.5.5.5.4 Spacing. Space (to give visual separation) shall be provided between unrelated segments on the fault isolation diagram.

3.5.5.5.5 Level. Fault isolation shall support the system maintenance concept, e.g., LRU or repair action (wiring diagnosis, adjustment, etc.).

3.5.5.5.6 Multiple item faults. If more than one item could cause a given fault, all items shall be listed in order of probable occurrence.

3.5.5.5.7 Unit identification. The isolated LRU shall be described using standard terminology and HLD. The final action shall state the applicable JG reference, e.g., Replace IMSC 2912CT001, (JG29-12-03).

3.5.5.5.8 Maintenance actions. Fault isolation procedures shall assume that operating personnel properly accomplished tasks required to arrive at a specific code. The recommended maintenance action shall be specific for the reported fault code and shall not duplicate action taken to arrive at the fault code.

3.5.5.5.9 Procedures. Fault isolation shall be in logic flow chart format (see figure 9). Action required shall be contained within a rectangular block. Monitored results, e.g., “OK/NOT OK”, shall be placed outside the block. Each flow chart shall contain complete procedures for each fault code. Procedures shall not refer the user to another chapter or manual in order to complete the isolation. Reference within a subsystem shall be permitted, e.g., referring to a fault code which provides a built-in-test equipment (BITE) check. Isolation procedures shall consist of appropriate fault codes followed by a series of fault isolation actions terminating in fault correction instructions. The flow chart shall proceed from left to right, top to bottom. Final corrective action blocks shall be located at the right-hand margin of the cell of the chart. Blocks shall be the same width and align vertically. The procedures shall be based on the most direct method of isolating the fault. Maximum use of BITE and self test shall be used. Fault indicators shall not be used in FI procedures unless they can be reset prior to testing. The selection and sequence of isolation steps shall take into consideration the following:

- a. The probability of success of an action.
- b. The time required for an action.
- c. Parts accessibility and replaceability.
- d. The interchangeability of parts and system redundancy.
- e. The availability of maintenance tools and equipment.
- f. Reliability (mean time between failure (MTBF)).

3.5.5.5.10 Wording. Wording shall be succinct. Supplementary information and notes shall be separated from the diagrams blocks. Individual isolation steps shall be numbered consecutively.

3.5.5.5.11 Traceability. Each final action shall be traceable to the steps taken. There shall be only one branch for each final action.

3.5.5.5.12 Basic procedures. Where possible basic procedures shall be provided that do not require special test equipment. If required, fault isolation procedures shall permit use of specialized test equipment when the fault cannot be isolated to an LRU/wiring fault by other means.

3.5.5.5.13 Diagram references (electrical and mechanical). References shall be provided to the wiring and schematic diagrams contained in the WD and SD manuals.

Electronic media requirement: References shall be linked to the data to which it applies.

3.5.5.6 Supplemental data. (See figure 11.) Supplemental data may include conditions necessary to operate and test support equipment needed to accomplish fault isolation steps.

**MIL-DTL-83495C (USAF)
W/AMENDMENT 1**

Electronic media requirements: Supplemental data shall be contained in its own chunk.

Print media requirements: Supplemental information shall be located within the manual immediately following the fault isolation procedure (see 3.4.3.2.1.2.1e.) or at the end of the chapter.

3.6 Wiring data (WD) manual. The wiring data manual shall provide wiring information for the entire equipment or system and shall be prepared as a single manual, or separate system manuals, as specified by the acquiring activity (see 6.2u.). And shall be developed according to the MIL-HDBK-863. The first manual shall contain chapters one through three. Chapter 4 and subsequent shall be prepared by system. If specified by the acquiring activity, (see 6.2).

Electronic media requirements: Page count restrictions do not apply.

Print media requirements: If the single manual exceeds 800 pages (400 sheets), separate system manuals shall be prepared. The WD manual shall be combined with the SD manual unless the count exceeds 800 pages (400 sheets). Foldout pages shall be used only when approved by the acquiring activity. Diagrams shall be rotated 90 degrees counterclockwise to preclude the use of foldouts. When used, foldouts shall follow the last applicable text; turn pages shall not be used.

3.6.1 Front matter. Front matter shall be prepared in accordance with the requirements of MIL-STD-38784 and applicable requirements specified herein (see 3.1), except there shall be no list of illustrations.

Electronic media requirements: List of diagrams shall link to the data to which it applies.

Print media requirements: Chapter 4 and subsequent system manuals shall contain no front matter except title and list of effective diagrams.

3.6.2 Chapter 1 general. The following specific requirements shall apply to this chapter:

3.6.2.1 Applicability. A listing of the models, types and series of vehicles or equipment if more than one configuration is covered (see 3.1.7).

3.6.2.2 Data accessing system. Text with supporting illustrations shall include:

- a. An explanation of the SSSN and HLD number use.
- b. How to find the applicable wiring diagram.
- c. How to find the wiring effectivity.
- d. How to use the wire list to determine wire replacement information such as wire type, length, method of termination, crimping tool used, termination point, etc.
- e. How to use the connection list to find all wires of a terminal board, relay, connector, switch, etc.

3.6.3 Chapter 2, equipment list. All applicable descriptive text shall precede the equipment list. In addition to the requirements of MIL-HDBK-863. the equipment list shall contain the applicable CAGE codes and HLDs (equipment number designator) for each LRU described in the WD and SD manuals.

3.6.4 Chapter 3, wire harness and connection lists. All applicable descriptive text shall precede the wire harness and connection lists. The wire harness list and a connection list shall be developed according to MIL-HDBK-863.

3.6.5 Chapter 4 and subsequent, wiring diagrams. This chapter shall contain an Index of effective diagrams and point-to-point interconnect wiring diagrams, with associated charts developed according to MIL-HDBK-863. The index shall be located in the front of each system wiring diagram. For combined manuals, chapters shall be divided with a indicating only the chapter number and system tile.

3.7 Schematic diagrams (SD) manual. The SD manual shall be prepared in single manual format or separate manuals by system, as specified by the acquiring activity (see 6.2w.) and shall be developed according to MIL-HDBK-863.

Electronic media requirements: Page count restrictions do not apply.

Print media requirements: When specified, the SD manual shall be combined with the WD or GS manual unless this would cause the manual to exceed 800 pages (400 sheets).

**MIL-DTL-83495C (USAF)
W/AMENDMENT 1**

3.7.1 Front matter. Front matter shall be prepared in accordance with the requirements of MIL-STD-38784 and applicable requirements specified herein (see 3.1), except there shall be no list of illustrations or list of tables. An explanation of all symbols and abbreviations peculiar to the SD manuals, shall be provided. Pictures of the symbols shall be included.

3.7.2 Chapter 1, general. The following specific requirements shall apply to this chapter.

3.7.2.1 Applicability. A listing of equipment models, types and series, if more than one configuration is covered (see 3.1.7).

3.7.2.2 Data accessing system. The text and illustrated explanations shall describe:

- a. Explanation of the SSSN number and HLD use.
- b. How to find the applicable system schematic diagram.
- c. How to find the system schematic diagram effectivity.
- d. The use of system schematic diagrams.

3.7.2.3 Index of effective diagrams. Electronic media requirements: The index shall be linked to the data to which it applies.

Print media requirements: An index of effective diagrams shall be developed according to MIL-HDBK-863.

3.7.3 Chapter 2 and subsequent, schematic diagrams. Electronic media requirement: The book shall be chunked by chapters. Chapter 2 and subsequent shall contain minimal front matter and the system schematic diagrams.

Print media requirements: For combined manuals, chapters shall be divided with a indicating only the chapter number and system tile.

3.7.3.1 Purpose. The purpose is to aid the mechanic in understanding the troubleshooting process stated in the manual and to assist in troubleshooting. It shall contain procedures for faults not identified or not eliminated through the use of the fault isolation procedures.

3.7.3.2 Levels. Three levels of detail shall be used according to the requirements of MIL-HDBK-863. The most complete form of schematic shall be provided, regardless of level, to support system understanding and fault analysis of any electrical or mechanical system.

3.7.3.3 Format.

Electronic media requirement: The system title shall be placed in an area that will allow it to be persistently visible.

Print media requirements: Schematic format shall be either vertical or horizontal to suit the schematic requirement and shall be limited to 8 ½ x 11 inch size. Where one page is not sufficient, a multi-sheet illustration or foldout shall be prepared. Foldouts shall be located as near as possible to the applicable text. The acquiring activity shall approve the use of foldouts on a case-by-case basis.

4 VERIFICATION

4.1 Verification requirements. Verification Requirements. When the technical data produced according to this specification is offered for acceptance, all tests, reviews, and verifications required by the acquiring activity to determine that it conforms to the requirements in section 3 of the specification, shall be performed as specified in the solicitation or contract. The Air Force TO Policy and Procedures (AF TOPP) team, AFMC/A4UE, provides the specific requirements for verification of technical data developed and delivered through this specification, as well as guidance for including these requirements in the solicitation or contract (see TO 00-5-3, AF TO Life Cycle Management, 2.2.2).

4.2 Compliance. Technical manuals (TMs) shall meet all requirements of section 3 of this specification and the appropriate DTD appendix, as required by the acquiring activity (see 6.2). The requirements set forth in this specification shall become a part of the contractor's overall inspection system or quality program. The absence of any requirements in this specification shall not relieve the contractor of the responsibility of ensuring that all products or supplies, submitted to the government for acceptance, comply with all requirements of the contract. Use of sampling inspections shall be at the discretion of the contractor, and in

**MIL-DTL-83495C (USAF)
W/AMENDMENT 1**

accordance with commercially acceptable quality assurance procedures. However, use of sampling in QA procedures does not authorize submission of known defective material, either indicated or actual, nor does it commit the government to accept defective material.

5 PACKAGING

5.1 Packaging requirements. For acquisition purposes, the packaging requirements shall be as specified in the contract or order (see 6.2y). When the actual packaging of material is to be performed by DoD personnel, these personnel need to contact the responsible packaging activity to ascertain requisite packaging requirements. Packaging requirements are maintained by the Inventory Control Point's packaging activity within the Military Department's System Command. Packaging data retrieval is available from the Military Department's or Defense Agency's automated packaging files, CD-ROM products, or the responsible packaging activity.

6 NOTES

(This section contains information of a general or explanatory nature that may be helpful, but is not mandatory.)

6.1 Intended use. Technical manuals prepared in accordance with this specification are to be used for organizational on-equipment maintenance of installed CE equipment, SE, aircraft, missiles, space vehicles and equipment storage.

6.2 Acquisition requirements. Acquisition documents must specify the following:

- a. Title, number, and date of this document.
- b. Issue of the ASSIST data base to be cited in the solicitation, and if required, the specific issue of individual documents referenced (see 2.2.1, 2.2.2, 2.3).
- c. If the General Equipment and General Systems manuals will be combined, (see 3.2).
- d. If Chapters 1 through 4 are to be used and the type of information required (see 3.2.3.2.2).
- e. Whether associated JG manuals will not be prepared to support Chapter 13, Equipment Storage, (see 3.2.3.2.6).
- f. If Chapter 15, Support Equipment, will have associated JG manuals prepared (see 3.2.3.2.7).
- g. If Chapter 16, Siting Installation, will be used (see 3.2.3.2.8).
- h. If Chapter 17, Preparation for Use and Shipment, will be used (see 3.2.3.2.9).
- i. If Chapter 18, Weapons Instrumentation, will have associated JG manuals prepared (see 3.2.3.2.10).
- j. If Chapter 19, Training Equipment, will have associated JG manuals prepared (see 3.2.3.2.11).
- k. If combined General Systems manuals will be prepared and systems to be combined (see 3.3).
- l. If illustrations of peculiar equipment will follow the special tools and test equipment table (see 3.3.5.3.2.1).
- m. If JG manuals will be 5 by 8 inch or 8 ½ by 11 inch size (see 3.4.2.4).
- n. If the HLD will follow the first usage nomenclature (see 3.4.2.5).
- o. If foldout pages may be used in JG manuals (see 3.4.2.7).
- p. Determine the maintenance functions to be used in the JG manuals (see 3.4.3.2.1).
- q. Whether JG manuals will be used as checklist procedures (see 3.4.3.2.1.1.7).
- r. Whether the FI and FR manuals will be combined (3.5).
- s. Whether the FR and FI table of contents will be allowed to exceed two pages (3.5.5.1).
- t. If the Fault Isolation manual will duplicate the Fault Reporting Log Book (see 3.5.5.3).
- u. If the Wiring Data manual will be prepared in single manual format or separate manuals by system (see 3.6).
- v. If the WD manual will be combined with the SD manual (see 3.6).

**MIL-DTL-83495C (USAF)
W/AMENDMENT 1**

- w. If the Schematic Diagram manual will be prepared in single manual format or separate manuals by system (see 3.7).
- x. If the Schematic Diagram manual will be independent, combined with the General Systems manual(s), or combined with the Wiring Data manual(s) (see 3.7).
- y. Packaging requirements will be as specified in 5.1.

6.3 Technical manuals. The requirement for technical manuals should be considered when this specification is applied on a contract. If technical manuals are required, specifications and standards that have been authorized and assigned an Acquisition Management Systems Control (AMSC) number must be listed on a separate Contract Data Requirements List (DD Form 1423), which is included as an exhibit to the contract. The technical manuals must be acquired under separate contract line item in the contract.”

6.4 Definitions.

6.4.1 Component. A unit, consisting of accessories that collectively perform a specific functional operation, which is normally removed and replaced as a single item. Examples are engines, guidance and control packages, gearboxes, hydroelectric-mechanical actuators, servos, receivers, transmitters, motors, etc.

6.4.2 Consumable materials. Sealants, lubricants, gaskets, seals, cleaning solvents, paint, etc., are considered consumable items.

6.4.3 Faults.

6.4.3.1 Basic fault. A "basic fault" requires additional diagnostics to complete.

6.4.3.2 Subfault. Completion of the basic fault analysis results in a "sub fault". Subfault analysis completes the isolation process.

6.4.3.3 Single entry fault. Fault isolation that terminates the analysis process without generating a subfault.

6.4.4 Follow-on maintenance. A maintenance action required upon completion of a function or task, to return the equipment to operation.

6.4.5 Higher level designator (HLD). An enhanced reference designation indicator (RDI) identification code assigned by the contractor and given to all LRUs and SRUs. HLDs are assigned according to the requirements of MIL-HDBK-863. and DOD-STD-1808. The code reflects the functional system, subsystem, sub-subsystem, equipment class letter(s), as sequentially assigned number, and a suffix letter, when required. For example: An HLD for a flight station temperature control relay could be 2161K003 (21-air conditioning system, 6...-temp control subsystem, ...1-flight station subsystem, K-relay, 003-third relay on the drawing).

6.4.6 Line replaceable unit (LRU). An LRU is a unit which can be removed from a system and replaced with a like operating unit, in order to restore the operational capability of the next higher system.

6.4.7 Maintenance procedure. This type of procedure is specific in nature and is performed on the vehicles systems, components, LRUs, and SRUs. Systems 18 and 21 through 99 normally contain functional maintenance procedures. A typical functional maintenance procedure includes:

1. Input condition page for each function (remove, install, etc.)
 - a. Task or series of tasks
 - 1) Steps with illustrations.

6.4.8 Maintenance function. A task or series of related maintenance tasks performed upon installed equipment or component. Examples of maintenance functions include: Removal, installation, adjustment, calibration, component checkout, cleaning, etc.

6.4.9 Maintenance task. A group of related maintenance steps with a definite beginning and end. A task is a complete start-to-finish, step-by-step maintenance action in a logical sequence of occurrence. One or more tasks may be required to complete a function. Separate instructions within a task are called steps.

6.4.10 Maintenance step. Generally, a step is a single maintenance action, such as setting a switch to the OFF position. In certain cases, a step may be a series of identical actions, e.g., removing seven bolts.

**MIL-DTL-83495C (USAF)
W/AMENDMENT 1**

6.4.11 Nomenclature. Two types of nomenclature apply to the OMMS:

6.4.11.1 Official nomenclature. A name assigned by engineering, or other logistics disciplines, which designate a particular item's type, model, or series, for example, B-2A, AN-ALQ 135R.

6.4.11.2 Standard nomenclature. The name given to a unit (LRU, SRU, etc.) which reflect the common maintenance usage.

6.4.12 On-Equipment maintenance. On-equipment maintenance is the responsibility of, and performed by, a using organization on its assigned equipment, e.g., aircraft, missiles, support equipment (SE), communications electronic (CE) equipment, etc. It normally consists of functional checkout and end-to-end testing, inspecting, servicing, lubrication, adjusting, removing and replacing parts and assemblies. An organization may perform multi-levels of maintenance on the end-item; on-equipment and intermediate levels are indistinguishable. For example, technicians may be dispatched from fixed or mobile shops and perform support work on installed equipment or remove and replace large assemblies, e.g., fire control system, egress systems, fuel cells, wing and landing gear assemblies, etc.; generally, no distinction can be drawn between on-equipment and intermediate maintenance.

6.4.13 On-equipment maintenance manual set. This set of technical manuals is comprised of those manuals that are necessary to support on-equipment maintenance. For this specification, those technical manuals are identified as follows:

6.4.13.1 General equipment (GE) manual. This manual describes the overall equipment, providing a brief description of systems and subsystems. It also provides an overview of the OMMS, its structure, arrangement, and how the data are to be used.

6.4.13.2 General system (GS) manual. This manual(s) provides detailed system and subsystem description, theory of operation, main features, and support data necessary to complement the JG manuals.

6.4.13.3 Job guide (JG) manual. This manual(s) provides detailed procedures for organizational maintenance. The manual(s) is a step-by-step set of "how-to" instructions.

6.4.13.4 Fault isolation (FI) and fault reporting (FR) manuals. The FI manual provides troubleshooting data to correct faults identified and coded by the FR manual, and provide fault descriptions and fault isolation procedures for specific faults identified by any other method. The FR manual provides a means of conveying fault reporting information between operating and maintaining personnel. It contains operational fault identification and reporting instructions. These manuals may be combined at the direction of the acquiring activity when size and complexity allows.

6.4.13.5 Wiring data (WD) manual. This manual provides a complete set of wiring data for the entire equipment excluding those schematics addressed below.

6.4.13.6 Schematic diagram (SD) manual. This manual provides a complete set of system and subsystem schematics prepared and presented in the three level format of MIL-HDBK-863.

6.4.13.7 Combined manual. When system size and complexity allow, manuals may be combined (GE/GS, FI/FR, GS/SD and WD/SD) (see 3.2) and the acquiring activity approves..

6.4.13.8 Related manuals. Other related manuals, for which preparation requirements are not contained herein, are Illustrated Parts Breakdown Manuals, Structural Repair Manuals, Work Unit Code Manuals, Inspection and Maintenance Requirements Manuals and associated Work Cards, and Checklists. These manuals, although prepared to separate specifications, must be compatible with the keyed reference system (SSSN, HLD) used in this specification.

6.4.14 Repeated task/sequence. A task within a function that requires repeating following the completion of a subsequent task.

6.4.15 Repeated sequence of tasks. Repeated sequences occur when a group of tasks must be used more than once within a function. The primary reason for such repeats is that many systems have alternate or emergency systems to be checked.

6.4.16 Requirement for assistance. The requirement for assistance occurs when:

**MIL-DTL-83495C (USAF)
W/AMENDMENT 1**

- a. The function requires cooperation, coordination, or other teamwork under the direction of a primary technician.
- b. The function involves large or heavy items that would be dangerous or difficult for one technician to handle.
- c. Simple observations or actions must be taken in conjunction with the actions of the primary technician at some location out of the technician's sight or reach.

6.5 Subject term (key word) listing.

Fault isolation
Fault reporting
General equipment
General system
Job guide
Higher level designator
HLD
Maintenance
OMMS
Organizational
SSSN
Sub-subsystem
Subsystem4/
System

6.6 Changes from previous issue. The margins of this specification are marked with vertical lines to indicate where changes from the previous issue were made. This was done as a convenience only and the Government assumes no liability whatsoever for any inaccuracies in these notations. Bidders and contractors are cautioned to evaluate the requirements of this document based on the entire content irrespective of the marginal notations and relationship to the last previous issue.”

**MIL-DTL-83495C (USAF)
W/AMENDMENT 1**

TO 1F-1A-2-21JG-00-1

TABLE OF CONTENTS

Chapter	Page
TO 1F-1A-2-21JG-00-1 AIR CONDITIONING GENERAL (21-00-00)	
FOREWORD	iii
Purpose	iv
Scope	v
Models Covered	vii
Nonstandard Abbreviations	viii
Related Publications	ix
TCTO List	xi
SAFETY SUMMARY	x
1. GENERAL SYSTEM INFORMATION (21-00-00)	
21-00-00 General Maintenance Practices	1-1
System Maintenance Practices	1-1
Inspection	1-2
Component Replacement Checks	1-4
Component Repair Limits	1-7
2. SYSTEM MAINTENANCE PROCEDURES (21-00-00)	
21-00-00 General Information	2-1
21-00-01 System Operational Checkout	2-4
TO 1F-1A-21JG-10-1 COMPRESSION (21-10-00)	
3. COMPRESSION (21-10-00)	
21-10-00 General Information	
21-10-01 Flow Controller (2110FV001)	

Change 2
1

FIGURE 1. Example JG table of contents

MIL-DTL-83495C (USAF)
W/AMENDMENT 1

1F-1A-2-21JG20-1

2-2. ELECTRONIC EQUIPMENT COOLING SET MODULATING VALVE ASSEMBLY, 2121FV1, REMOVAL AND INSTALLATION.

INPUT CONDITIONS

Applicability: All

Required Conditions:

- Aircraft safe for maintenance (JG10-30-01)
- Gun barrels removed (JG94-51-02)
- **C** (1,2) Gun trough access cover B removed (General Maintenance)
- **C** (1,2) Cockpit cold air check valve removed (JG21-22-11)
- **D** (3,4) UHF radio control removed (JG23-22-06)
- **D** (3,4) Closeout panel A removed (General Maintenance)
- **D** (3,4) Gun trough access cover A removed (General Maintenance)

Personnel Recommended: **C** One, **D** Two

- Technician A performs removal and installation of valve.
- **D** (3,4) Technician B assists in removal and installation of valve (access panel 2405).

21-21-02

2-9

FIGURE 2. Example JG input conditions

**MIL-DTL-83495C (USAF)
W/AMENDMENT 1**

TO 1F-1A-2-21JG-20-1

2-2. (Contd)

Support Equipment:

(2,4) Adapter Hose, Part No. 16A41006-1

(2,4) Generator Set, Type A/M32A-60A or equivalent

Maintenance Platform, Type B-1 or equivalent

(2,4) Torque Wrench (torque range 0-80 inch-pounds)

Consumables:

Nomenclature	Specification/ PN	CAGE Code	Use	Reference
Cheesecloth or equivalent	CCC-C-123	20999	AR	2,4
Grease, Pneumatic	MIL-G-1234	81349	AR	2,4
Leak Detec- tion Compound	MIL-L-12345	81349	AR	2,4
Packing	MS1234-04	81352	1	2,4
Tape, Elec- trical Lacing	DPS 3CL AR	00768	4	2

Safety Conditions: None

Additional Data:

Reference	Purpose
(2,4) TO 1F-1A-2-00GE-00-1	To prepare surfaces for electrical bonding

21-21-02

2-10

FIGURE 2. Example JG input conditions - Continued.

MIL-DTL-83495C (USAF)
W/AMENDMENT 1

1F-1A-2-21JG-20-1

**2-2-1. (C) REMOVAL OF ELECTRONIC EQUIPMENT COOLING SET
MODULATING VALVE ASSEMBLY.**

NOTE

- All serviceable parts will be retained for reinstallation.
- Protective devices shall be installed on all open tubes, ports, and electrical disconnect.

1. Disconnect electrical connector.
2. Remove three screws and three washers.
3. Remove two nuts, two screws, and bracket.
4. Remove tube nut from elbow.
5. Remove two couplings and reposition two sleeves.
6. Remove modulating valve assembly and connected tubing.
7. Remove tube nut from union.
8. Remove and discard four packings.

NOTE

If valve is to be reinstalled, omit step 9.

9. Remove union and packing. Discard packing.

21-21-02

(2-11 blank)/2-12

FIGURE 3. Example JG task.

MIL-DTL-83495C (USAF)
W/AMENDMENT 1

TO 1F-1A-2-21JG-20-1

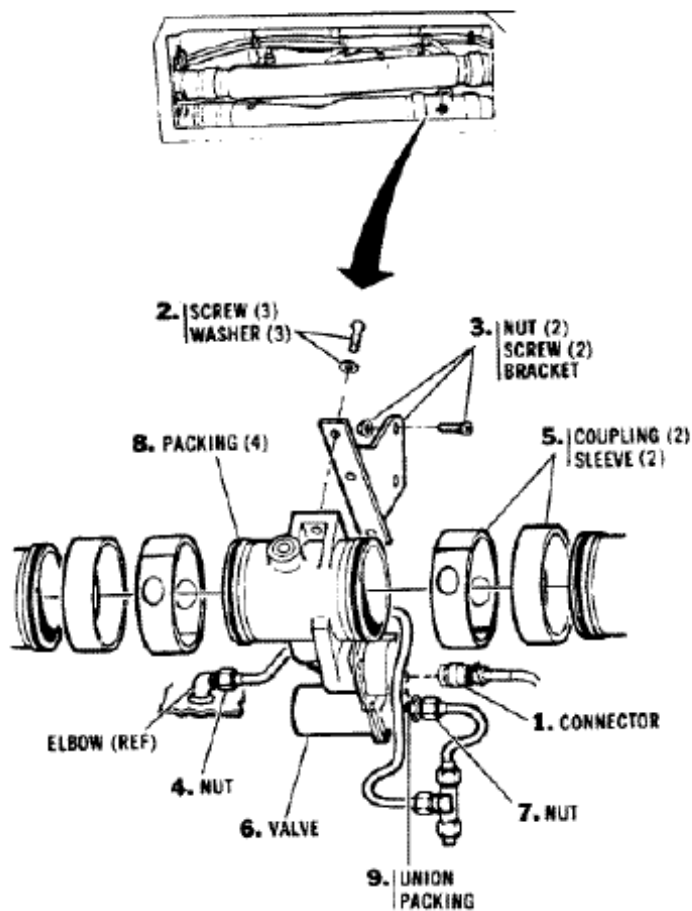

Figure 2-2-1.

21-21-02

2-13

FIGURE 3. Example JG task. - Continued.

MIL-DTL-83495C (USAF)
W/AMENDMENT 1

TF-1A-2-00FR-00-1

SECTION I

AIR-CONDITIONING SYSTEM
TABLE OF CONTENTS

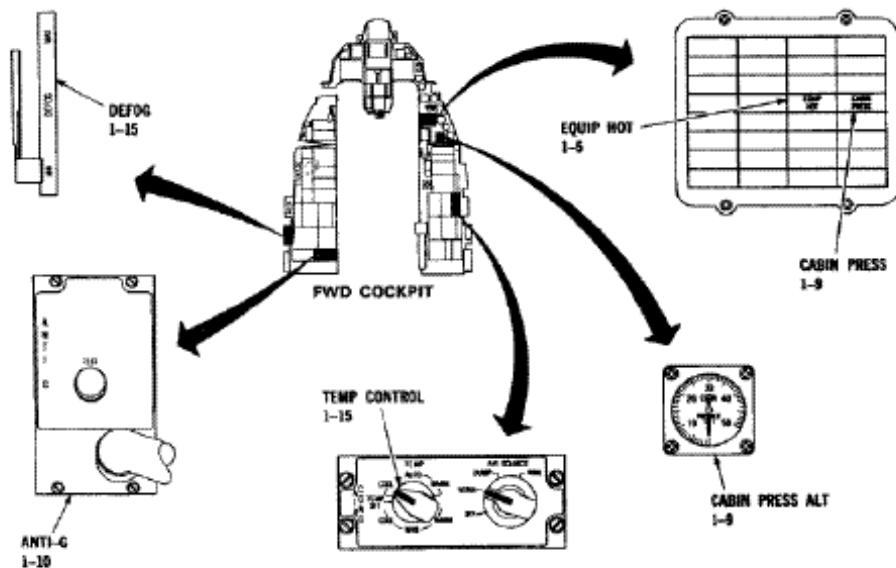

<u>CONTENTS</u>	<u>PAGE</u>
ANTI-G	1-10
CABIN PRESS	1-9
CABIN PRESS ALT	1-9
Cockpit Airflow	1-7
Compression Pilot Detectable Faults Not Listed	1-3
Cooling Pilot Detectable Faults Not Listed	1-13
DEFOG (TEMP Control AUTO)	1-15
DEFOG/TEMP Control Pilot Detectable Faults Not Listed	1-15
Distribution Pilot Detectable Faults Not Listed	1-7
EQUIP HOT	1-5
Pressurization Pilot Detectable Faults Not Listed	1-10
TEMP Control	1-15

	EFFECTIVITY:	AIR-CONDITIONING
		1-1

FIGURE 4. Example fault reporting manual table of contents

MIL-DTL-83495C (USAF)
W/AMENDMENT 1

TF-1A-2-00FR-00-1

SECTION I

AIR-CONDITIONING SYSTEM
TABLE OF CONTENTS

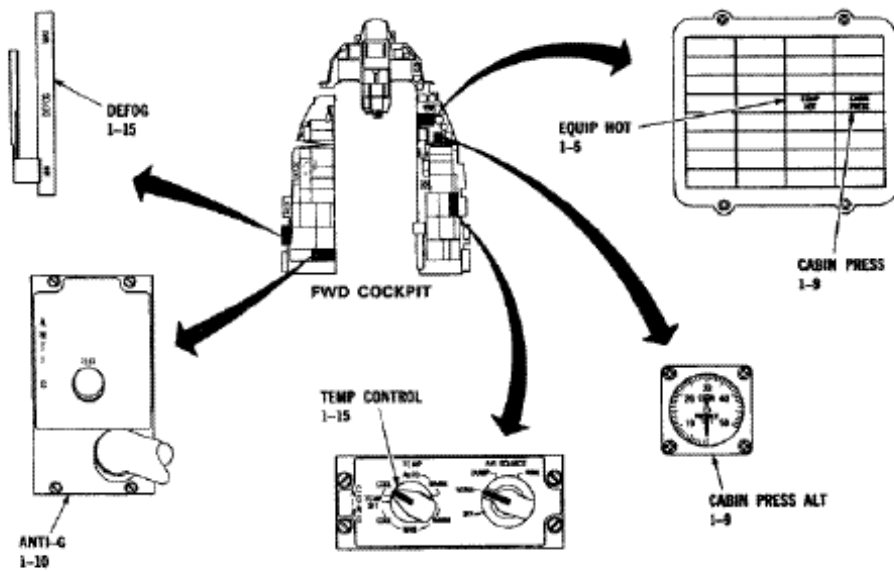

<u>CONTENTS</u>	<u>PAGE</u>
ANTI-G	1-10
CABIN PRESS	1-9
CABIN PRESS ALT	1-9
Cockpit Airflow	1-7
Compression Pilot Detectable Faults Not Listed	1-3
Cooling Pilot Detectable Faults Not Listed	1-13
DEFOG (TEMP Control AUTO)	1-15
DEFOG/TEMP Control Pilot Detectable Faults Not Listed	1-15
Distribution Pilot Detectable Faults Not Listed	1-7
EQUIP HOT	1-5
Pressurization Pilot Detectable Faults Not Listed	1-10
TEMP Control	1-15

	EFFECTIVITY:	AIR-CONDITIONING
		1-1

FIGURE 5. Example fault isolation table of contents.

MIL-DTL-83495C (USAF)
W/AMENDMENT 1

1F-1A-2-00FR-00-1

FAULT IDENTIFICATION AND DESCRIPTION
DISTRIBUTION

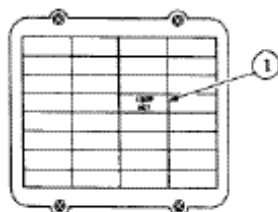

AFT EQPT BAY DC PWR PNL:
1. CABIN TEMP CONTROL

RH STRAKE DC PWR PNL:
2. ENGINE BLEED AIR
3. ENVIR CONTROL SYSTEM

FAULT LOCATION	
Fwd Cockpit	01
Aft Cockpit	
Not Applicable	00

NOTE

- If EQUIP HOT light comes on, this indicates malfunction causing insufficient cooling air. Advancing throttle above 80% may put light out within one minute to avoid avionics shutdown and mission abort.
- When air in system is at or near dew point, moisture entering electronic equipment cooling sensor/controller may cause EQUIP HOT light.

① EQUIP HOT

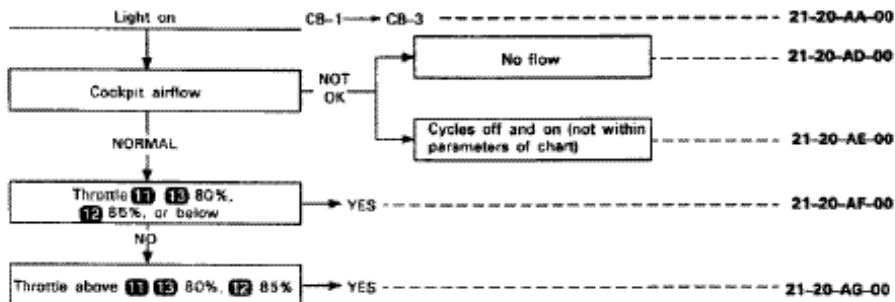

EFFECTIVITY:

AIR-CONDITIONING
(DISTRIBUTION)

1-5

FIGURE 6. Example fault reporting manual format.

MIL-DTL-83495C (USAF)
W/AMENDMENT 1

1F-1A-2-21FI-00-1

SECTION I
FAULT IDENTIFICATION AND DESCRIPTION COMPRESSION (2110)
PILOT DETECTABLE FAULTS

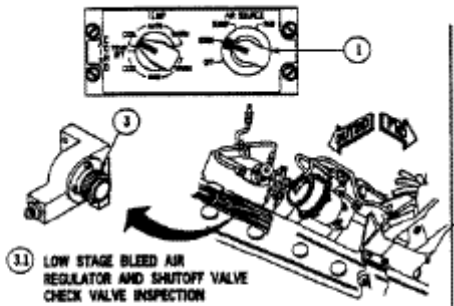

RH STRAKE DC PWR PNL:
1. ENGINE BLEED AIR
AFT EQPT BAY DC PWR PNL:
2. CABIN TEMP CONTROL

FAULT LOCATION	
Not Applicable	00

① AIR SOURCE
(No pilot fault data provided at this time.
Use fault code 21-10-00-00)

② COMPRESSION PILOT DETECTABLE FAULTS NOT LISTED ----- 21-10-00-00

MAINTENANCE DETECTABLE FAULTS

③ OVERPRESSURE INDICATOR EXTENDED ----- 21-10-XD-00

④ LOW STAGE BLEED AIR REGULATOR AND SHUTOFF VALVE
CHECK VALVE INSPECTION ----- 21-10-ZL-00

⑤ COMPRESSION MAINTENANCE DETECTABLE FAULTS NOT LISTED ----- 21-10-00-00

EFFECTIVITY:		
		21-10-00
		1-1

FIGURE 7. Example fault isolation manual format

MIL-DTL-83495C (USAF)
W/AMENDMENT 1

1F-1A-2-21FI-00-1

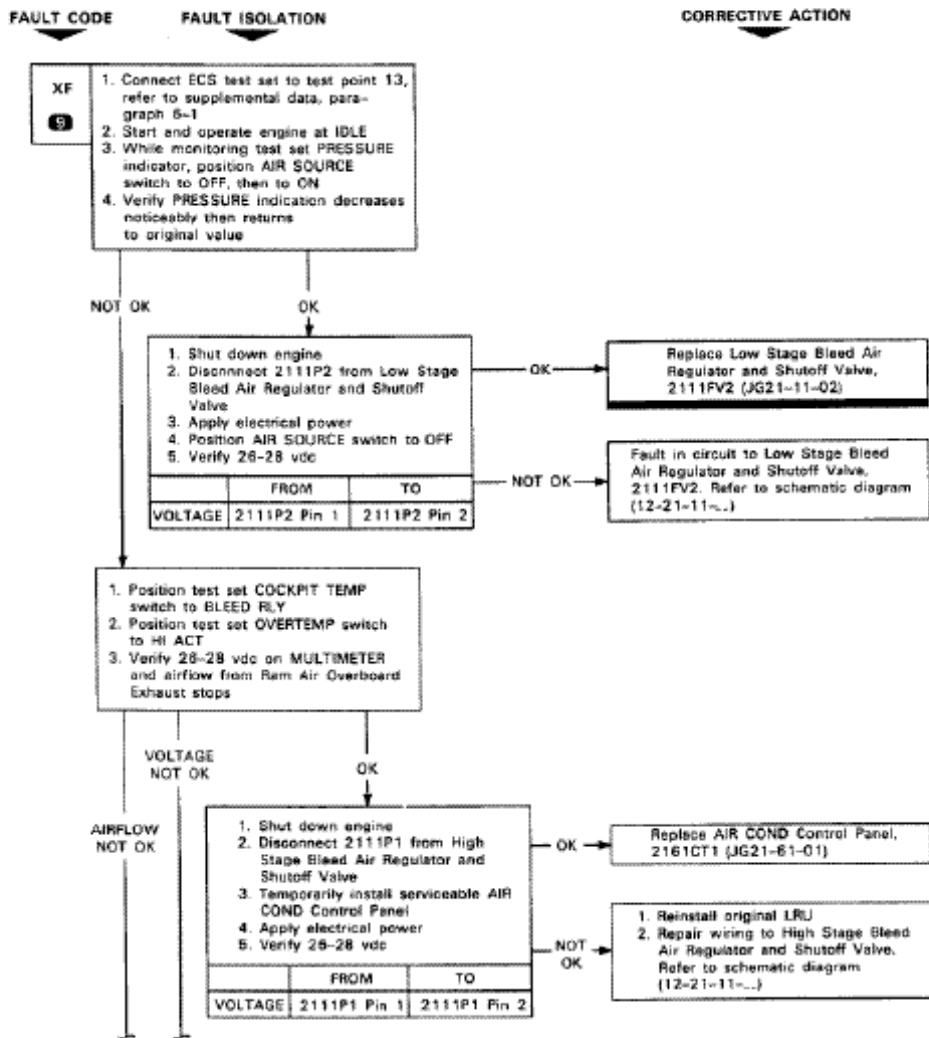

EFFECTIVITY:		21-10-00
		1-15

FIGURE 7. Example fault isolation manual format - Continued.

MIL-DTL-83495C (USAF)
W/AMENDMENT 1

1F-1A-2-00FR-00-1

LOG BOOK REPORT
DISTRIBUTION

- | | |
|--|--|
| <p>① <u>EQUIP HOT.</u></p> <p>AA EQUIP HOT; light on.</p> <p>AD EQUIP HOT; light on; cockpit air-flow not OK; no flow.</p> <p>AE EQUIP HOT; light on; cockpit air-flow not OK; cycles off and on (not within parameters of chart).</p> <p>AF EQUIP HOT; light on; cockpit air-flow normal; throttle ① ② 80%, ③ 85%, or below.</p> <p>AG EQUIP HOT; light on; cockpit air-flow normal; throttle above ① ③ 80%, ④ 85%.</p> | <p>BA Cockpit airflow; not OK.</p> <p>BD Cockpit airflow; not OK; contains excessive moisture.</p> <p>BE Cockpit airflow; not OK; low flow or no flow; EQUIP HOT light off.</p> <p>BF Cockpit airflow; not OK; cycles off and on; EQUIP HOT light off.</p> |
| <p>② <u>COCKPIT AIRFLOW.</u></p> | <p>③ <u>DISTRIBUTION PILOT DETECTABLE FAULTS NOT LISTED</u></p> <p>00 Distribution pilot detectable faults not listed. Describe symptoms in detail.</p> <p><u>DELETED FAULT CODES</u>... AH,.....
BG, BJ, BH, and BK</p> |

<p>AIR-CONDITIONING (DISTRIBUTION)</p> <p>1-8</p>	<p>EFFECTIVITY:</p>	
--	---------------------	--

FIGURE 8. Example fault reporting manual log book report.

**MIL-DTL-83495C (USAF)
W/AMENDMENT 1**

1F-1A-2-21F1-00-1

**LOG BOOK REPORT
DISTRIBUTION (2120)**

PILOT DETECTABLE FAULTS

<p>① <u>EQUIP HOT LIGHT ON.</u></p> <p>AA EQUIP HOT light on.</p> <p>AD EQUIP HOT light on; cockpit airflow not OK; no flow.</p> <p>AE EQUIP HOT light on; cockpit airflow not OK; cycles off and on (not within parameters of chart).</p> <p>AF EQUIP HOT light on; cockpit airflow normal; throttle 80%, ⑩ 85% or below.</p> <p>AG EQUIP HOT light on; cockpit airflow normal; throttle ⑩ 80%, ⑩ 85% or below.</p>	<p>BA Cockpit airflow not OK.</p> <p>BD Cockpit airflow not OK; contains excessive moisture.</p> <p>BE Cockpit airflow not OK; low flow or no flow; EQUIP HOT light off.</p> <p>BF Cockpit airflow not OK; cycles off and on; EQUIP HOT light off.</p>
<p>② <u>COCKPIT AIRFLOW.</u></p>	<p>③ <u>DISTRIBUTION PILOT DETECTABLE FAULTS NOT LISTED.</u></p> <p>00 Distribution pilot detectable faults not listed. Describe symptoms in detail.</p> <p><u>DELETED FAULT CODES.</u> None</p>

OPERATIONAL CHECKOUT DETECTABLE FAULTS

<p>④ <u>EQUIPMENT COOLING CONTROL SET WITH EXTERNAL AIR SOURCE.</u></p> <p>XD Test point 50 pressure not within desired range.</p> <p>XE Priority valve did not go full open; AIR SOURCE switch to OFF.</p> <p>XF EQUIP HOT light did not come on; AIR SOURCE switch to OFF.</p>	<p>XG Priority valve closes but does not modulate when AIR SOURCE switch positioned from OFF to NORM.</p> <p>XH EQUIP HOT light did not go off when AIR SOURCE switch positioned from OFF to NORM.</p>
<p>⑤ <u>RADAR COOLING SHUTOFF VALVE.</u></p> <p>XJ No airflow from MLPRF and PSP cooling air exhaust; external air applied; electrical power off.</p>	

	EFFECTIVITY:	
<p>21-20-00</p> <p>2-4</p>		

FIGURE 9. Example fault isolation manual log book report.

MIL-DTL-83495C (USAF)
W/AMENDMENT 1

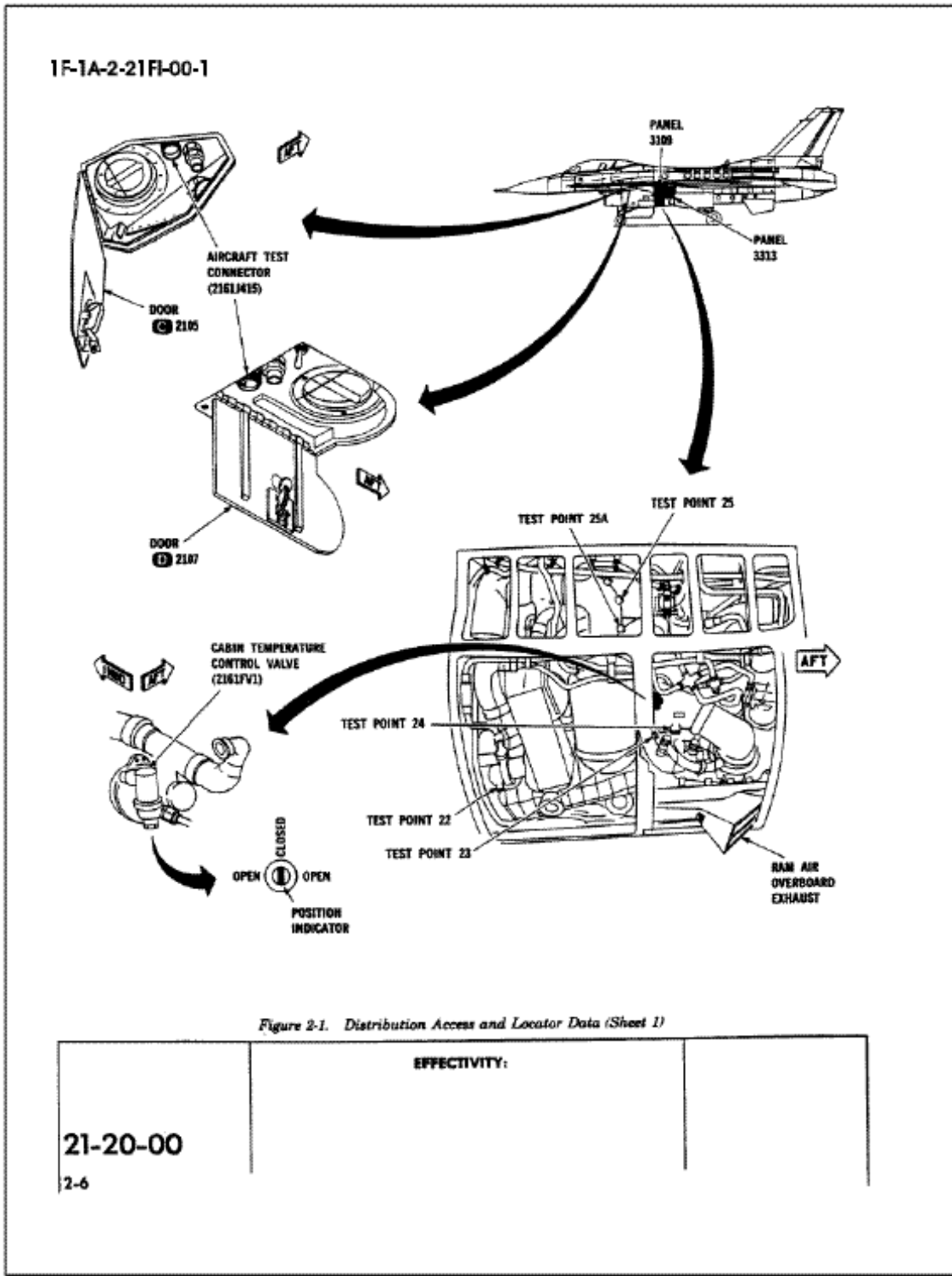

FIGURE 10. Example fault isolation manual locator data.

**MIL-DTL-83495C (USAF)
W/AMENDMENT 1**

1F-1A-2-21F-00-1

**SECTION VI
SUPPLEMENTAL DATA**

6-1. ECS TEST SET CONNECTION AND DISCONNECTION. ECS test set connection and disconnection procedures are to be used in conjunction with fault isolation procedures.

CAUTION

To avoid contaminating the environmental control system, lubricants shall not be used except where specified.

Support Equipment:

Adapter Hose, Part No. 16A41006-1 or equivalent

Cordage Assembly, Part No. 5-62887-1 or equivalent (as required)

ECS Test Set, Part No. H 301-3 or equivalent

Electrical Adapter, ECS Connector, Part No. 16A41148-1 or equivalent

Fan Air Modulating Valve Simulator, Part No. 164125561-1

Generator Set, Type A/M32A-60A or equivalent

Microphone Headsets, Part No. H-133C/AIC or equivalent (as required)

Torque Wrench (torque range 0-155 inch-pounds)

Protective Equipment:

Gloves, Rubber, ZZ-G-381

Goggles, Industrial, GGG-G-521

ECS Test Set Connection.

NOTE

Test hoses are to be connected between aircraft test points identified in fault isolation procedures and test set connection ports for desired test results. Depending on required pressure, use appropriate range input. Example: If fault isolation procedure reads, "Verify 28-40 psig at test point 13," the test hose should be connected between test point 13 and the 300 PSI INPUT connection port number 2 (figure 6-1). To read test point 13 pressure on the test set PRESSURE gage, the test set SELECT valve and PRESSURE switch must be positioned to correspond to the test hose connection (table 6-1).

- Position ECS test set base panel (BP) switches and valves. Refer to table 6-2.
- Remove access panels/open access doors as required.
- Remove cap(s) and/or plug(s) from test point(s) identified in FI procedure and connect test hose(s).
- Connect opposite end of test hose(s) to appropriate test set input connection port(s) (figure 6-1).
- Connect ECS test set to aircraft test connector (2161J415) (paragraph 6-3).
- Connect test probe if required to aircraft test point identified in FI procedure.
- Connect probe cable to test probe (if required).
- Connect opposite end of probe cable to test set BP AUX TEMP INPUT (figure 6-3) (if required).
- Connect electrical power (paragraph 6-4).

	EFFECTIVITY:	
		6-1

FIGURE 11. Example fault isolation manual supplemental data.

**MIL-DTL-83495C (USAF)
W/AMENDMENT 1**

**APPENDIX A
GENERAL EQUIPMENT (GE) MANUAL
DOCUMENT TYPE DEFINITION (DTD) SUBSET**

A.1 SCOPE.

A.1.1 Scope. DTDs are based on rules outlined in MIL-PRF-28001, and ISO 8879. The DTD subset referenced within this appendix provides the structure and content of documents prepared in accordance with this detail specification. For digital copies of the DTD, Tag Description Table, and the Attribute Description Table, see [A.4.1](#). This appendix is a mandatory part of this detail specification. The information herein is intended for compliance.

A.2 APPLICABLE DOCUMENTS.

A.2.1 General. The documents listed in this section are specified in sections [3](#), [4](#), and [5](#) of this specification. This section does not include documents cited in other sections of this specification or recommended for additional information or as examples. While every effort has been made to ensure the completeness of this list, document users are cautioned that they must meet all specified requirements of documents cited in sections 3, 4, or 5 of this specification, whether or not they are listed.

A.2.2 Government documents.

A.2.2.1 Specifications and standards. The following specifications and standards form a part of this document to the extent specified herein. Unless otherwise specified, issues of these documents are listed in the ASSIST data base (<https://assist.daps.dla.mil/>) and supplement thereto, cited in the solicitation (see [6.2b](#)).

SPECIFICATIONS

DEPARTMENT OF DEFENSE

MIL-PRF-28001

Markup Requirements and Generic Style Specification for
Electronic Printed Output and Exchange of Text

A.2.3 Non-government publications.

INTERNATIONAL ORGANIZATION FOR STANDARDIZATION

ISO 8879 (DoD adopted) Information Processing - Text and Office Systems - Standard Generalized Markup Language (SGML)

(Copies of these documents are available online at <http://www.iso.org/iso/home.html> or from the Standardization Document Order Desk, 700 Robbins Avenue, Building 4D, Philadelphia, PA 19111-5094.)

A.3 DIGITAL SUPPORT SUITES.

The following comprise the tools contained in the Digital Support Suite (DSS) used for authoring and rendering the GE manual doc type.

A.3.1 Document type definition. Data to be delivered digitally in accordance with this specification shall be tagged using the GE manual DTD found at the TMSS website (see [A.4.1](#)). This DTD provides the structure and content in accordance with the detail specification. The procedure for accomplishing this is found in MIL-PRF-28001 and ISO 8879.

A.3.2 Tag description table. The Tag Description Table (TDT) provides detailed descriptions of the elements contained in the GE manual DTD. The TDT contains the following: The element tagging structure, full element name, tag minimization requirements, element structure, reference elements, source paragraph, and attribute descriptions unique to the element. See [A.4.1](#) for information on obtaining this file in digital format.

A.3.3 Attribute description table. The Attribute Description Table (ATD) provides detailed descriptions of the attributes contained in the GE manual DTD. See [A.4.1](#) for information on obtaining this file in digital format.

**MIL-DTL-83495C (USAF)
W/AMENDMENT 1**

APPENDIX A

A.4 OBTAINING DSS FILES.

A.4.1 Obtaining DSS files with a .mil address. DTDs, TDTs, and other files in the DSS can be accessed at the Technical Manual Specifications and Standards (TMSS) website <https://techdata.wpafb.af.mil/tmss/index.html>. On the web page, the “Baseline” menu option in the left pane contains three bulleted options called “Specifications”, “Standards”, and “Handbooks”. Hover the cursor over “Specifications” and a listing of the TMSS specifications will appear. Hover over the desired specification number and another drop down list will appear that shows a list containing a PDF version of the specification and the associated appendices. To obtain the preferred DTD, select the desired appendix. The following items will appear on the downloading page: The name of the specification, the appendix number and name, the current version of the DSS, buttons to download the DTD, FOSI, screen FOSI, ATD, and the TDT, and a “Download” button to download the entire DSS zip file.

A.4.2 Obtaining files without a .mil address. For addresses other than .mil., access to the TMSS Community of Practice (CoP) must be attained via the Air Force (AF) Portal. For access to the AF Portal, the AF Portal help desk can be reached at commercial number (334) 416-5771, option 7 or toll free at (877) 596-5771, option 7. Once access is attained to the Portal, navigate to the TMSS CoP at <https://afkm.wpafb.af.mil/community/views/home.aspx?Filter=OO-LG-MC-38> to download DTDs, TDTs, and other files contained in the DSS. A DSS can be downloaded by selecting the “Digital Support Suites (DSSs)” link under the “Document Management” section. A listing of the most current zip files for the DSSs appears. Select the appropriate zip file to download.

A.4.3 TMSS support. Please address any comments or questions relating to the DSS and/or specifications and standards to SGMLSUPPORT@wpafb.af.mil or to Technical Manual Specifications and Standards, ESC/HGGI, 4170 Hebble Creek Road, Building 280, Door 15, Wright-Patterson AFB OH 45433-5006.

**MIL-DTL-83495C (USAF)
W/AMENDMENT 1**

**APPENDIX B
GENERAL SYSTEM (GS) MANUAL
DOCUMENT TYPE DEFINITION (DTD) SUBSET**

B.1 SCOPE.

B.1.1 Scope. DTDs are based on rules outlined in MIL-PRF-28001, and ISO 8879. The DTD subset referenced within this appendix provides the structure and content of documents prepared in accordance with this detail specification. For digital copies of the DTD, Tag Description Table, and the Attribute Description Table, see [A.4.1](#). This appendix is a mandatory part of this detail specification. The information herein is intended for compliance.

B.2 APPLICABLE DOCUMENTS.

B.2.1 General. The documents listed in this section are specified in sections 3, 4, or 5 of this specification. This section does not include documents cited in other sections of this specification or recommended for additional information or as examples. While every effort has been made to ensure the completeness of this list, document users are cautioned that they must meet all specified requirements of documents cited in sections 3, 4, or 5 of this specification, whether or not they are listed.

B.2.2 Government documents.

B.2.2.1 Specifications and standards. The following specifications and standards form a part of this document to the extent specified herein. Unless otherwise specified, issues of these documents are listed in the ASSIST data base (<https://assist.daps.dla.mil>.) and supplement thereto, cited in the solicitation (see [6.2b](#)).

SPECIFICATIONS

DEPARTMENT OF DEFENSE

MIL-PRF-28001

Markup Requirements and Generic Style Specification for Electronic Printed Output and Exchange of Text

B.2.3 Non-government publications.

STANDARDS

INTERNATIONAL ORGANIZATION FOR STANDARDIZATION

ISO 8879 (DOD adopted)

Information processing - text and Office systems - standard generalized markup language (SGML)

(Copies of these documents are available online at <http://www.iso.org/iso/home.html> or from the Standardization Document Order Desk, 700 Robbins Avenue, Building 4D, Philadelphia, PA 19111-5094.)

B.3 DIGITAL SUPPORT SUITES.

The following comprise the tools contained in the Digital Support Suite (DSS) used for authoring and rendering the GS manual doc type.

B.3.1 Document type definition. Data to be delivered digitally in accordance with this specification shall be tagged using the GS manual DTD found at the TMSS website (see [A.4.1](#)). This DTD provides the structure and content in accordance with the detail specification. The procedure for accomplishing this is found in MIL-PRF-28001 and ISO 8879.

B.3.2 Tag description table. The Tag Description Table (TDT) provides detailed descriptions of the elements contained in the GS manual DTD. The TDT contains the following: The element tagging structure, full element name, tag minimization requirements, element structure, reference elements, source paragraph, and attribute descriptions unique to the element. See [A.4.1](#) for information on obtaining this file in digital format.

B.3.3 Attribute description table. The Attribute description table (ATD) provides detailed descriptions of the attributes contained in the GS manual DTD. See [A.4.1](#) for information on obtaining this file in digital format.

**MIL-DTL-83495C (USAF)
W/AMENDMENT 1**

APPENDIX B

B.4 OBTAINING DSS FILES.

B.4.1 Obtaining DSS files . See [A.4.1](#) for information on obtaining this file in digital format.

**MIL-DTL-83495C (USAF)
W/AMENDMENT 1**

**APPENDIX C
JOB GUIDE (JG) MANUAL
DOCUMENT TYPE DEFINITION (DTD) SUBSET**

C.1 SCOPE.

C.1.1 Scope. DTDs are based on rules outlined in MIL-PRF-28001, and ISO 8879. The DTD subset referenced within this appendix provides the structure and content of documents prepared in accordance with this detail specification. For digital copies of the DTD, Tag Description Table, and the Attribute Description Table, see [A.4.1](#). This appendix is a mandatory part of this detail specification. The information herein is intended for compliance.

C.2 APPLICABLE DOCUMENTS.

C.2.1 General. The documents listed in this section are specified in sections 3, 4, or 5 of this specification. This section does not include documents cited in other sections of this specification or recommended for additional information or as examples. While every effort has been made to ensure the completeness of this list, document users are cautioned that they must meet all specified requirements of documents cited in sections 3, 4, or 5 of this specification, whether or not they are listed.

C.2.2 Government documents.

C.2.2.1 Specifications and standards. The following specifications and standards form a part of this document to the extent specified herein. Unless otherwise specified, issues of these documents are listed in the ASSIST data base (<https://assist.daps.dla.mil>.) and supplement thereto, cited in the solicitation (see [6.2b](#).)

SPECIFICATIONS

DEPARTMENT OF DEFENSE

MIL-PRF-28001

Markup requirements and generic style specification for electronic printed output and exchange of Text

C.2.3 Non-government publications.

INTERNATIONAL ORGANIZATION FOR STANDARDIZATION

ISO 8879 (DoD adopted)

Information Processing - Text and
Office Systems - Standard Generalized
Markup Language (SGML)

(Copies of these documents are available online at :// <http://www.iso.org/iso/home.html> from the Standardization Document Order Desk, 700 Robbins Avenue, Building 4D, Philadelphia, PA 19111-5094.)

C.3 DIGITAL SUPPORT SUITES.

The following comprise the tools contained in the Digital Support Suite (DSS) used for authoring and rendering the JG manual doc type.

C.3.1 Document Type Definition. Data to be delivered digitally in accordance with this specification shall be tagged using the JG manual DTD found at the TMSS website (see [A.4.1](#)). This DTD provides the structure and content in accordance with the detail specification. The procedure for accomplishing this is found in MIL-PRF-28001 and ISO 8879.

C.3.2 Tag Description Table. The Tag Description Table (TDT) provides detailed descriptions of the elements contained in the JG manual DTD. The TDT contains the following: The element tagging structure, full element name, tag minimization requirements, element structure, reference elements, source paragraph, and attribute descriptions unique to the element. See [A.4.1](#) for information on obtaining this file in digital format.

C.3.3 Attribute Description Table. The Attribute Description Table (ATD) provides detailed descriptions of the attributes contained in the JG manual DTD. See [A.4.1](#) for information on obtaining this file in digital format.

C.4 OBTAINING DSS FILES.

C.4.1 Obtaining DSS files . See [A.4.1](#) for information on obtaining this file in digital format.

**MIL-DTL-83495C (USAF)
W/AMENDMENT 1**

**APPENDIX D
Fault Reporting (FR) Manual
DOCUMENT TYPE DEFINITION (DTD) SUBSET**

D.1 SCOPE.

D.1.1 Scope. DTDs are based on rules outlined in MIL-PRF-28001, and ISO 8879. The DTD subset referenced within this appendix provides the structure and content of documents prepared in accordance with this detail specification. For digital copies of the DTD, Tag Description Table, and the Attribute Description Table, see [A.4.1](#). This appendix is a mandatory part of this detail specification. The information herein is intended for compliance.

D.2 APPLICABLE DOCUMENTS.

D.2.1 General. The documents listed in this section are specified in sections 3, 4, or 5 of this specification. This section does not include documents cited in other sections of this specification or recommended for additional information or as examples. While every effort has been made to ensure the completeness of this list, document users are cautioned that they must meet all specified requirements of documents cited in sections 3, 4, or 5 of this specification, whether or not they are listed.

D.2.2 Government Documents.

D.2.2.1 Specifications and standards. The following specifications and standards form a part of this document to the extent specified herein. Unless otherwise specified, issues of these documents are listed in the ASSIST data base (<https://assist.daps.dla.mil>.) and supplement thereto, cited in the solicitation (see [6.2b](#)).

SPECIFICATIONS

DEPARTMENT OF DEFENSE

MIL-PRF-28001

Markup Requirements and Generic Style Specification for
Electronic Printed Output and Exchange of Text

D.2.3 Non-government publications.

INTERNATIONAL ORGANIZATION FOR STANDARDIZATION

ISO 8879 (DoD adopted)

Information Processing - Text and
Office Systems - Standard Generalized
Markup Language (SGML)

(Copies of these documents are available online at <http://www.iso.org/iso/home.html> or from the Standardization Document Order Desk, 700 Robbins Avenue, Building 4D, Philadelphia, PA 19111-5094.)

D.3 DIGITAL SUPPORT SUITES.

The following comprise the tools contained in the Digital Support Suite (DSS) used for authoring and rendering the FR manual doc type.

D.3.1 Document Type Definition. Data to be delivered digitally in accordance with this specification shall be tagged using the FR manual DTD found at the TMSS website (see [A.4.1](#)). This DTD provides the structure and content in accordance with the detail specification. The procedure for accomplishing this is found in MIL-PRF-28001 and ISO 8879.

D.3.2 Tag Description Table. The Tag Description Table (TDT) provides detailed descriptions of the elements contained in the FR manual DTD. The TDT contains the following: The element tagging structure, full element name, tag minimization requirements, element structure, reference elements, source paragraph, and attribute descriptions unique to the element. See [A.4.1](#) for information on obtaining this file in digital format.

D.3.3 Attribute Description Table. The Attribute Description Table (ATD) provides detailed descriptions of the attributes contained in the FR manual DTD. See [A.4.1](#) for information on obtaining this file in digital format.

D.4 OBTAINING DSS FILES.

D.4.1 Obtaining DSS files. See [A.4.1](#) for information on obtaining this file in digital format.

**MIL-DTL-83495C (USAF)
W/AMENDMENT 1**

**APPENDIX E
Fault Isolation (FI) Manual
DOCUMENT TYPE DEFINITION (DTD) SUBSET**

E.1 SCOPE.

E.1.1 Scope. DTDs are based on rules outlined in MIL-PRF-28001, and ISO 8879. The DTD subset referenced within this appendix provides the structure and content of documents prepared in accordance with this detail specification. For digital copies of the DTD, Tag Description Table, and the Attribute Description Table, see [A.4.1](#). This appendix is a mandatory part of this detail specification. The information herein is intended for compliance.

E.2 APPLICABLE DOCUMENTS.

E.2.1 General. The documents listed in this section are specified in sections 3, 4, or 5 of this specification. This section does not include documents cited in other sections of this specification or recommended for additional information or as examples. While every effort has been made to ensure the completeness of this list, document users are cautioned that they must meet all specified requirements of documents cited in sections 3, 4, or 5 of this specification, whether or not they are listed.

E.2.2 Government Documents.

E.2.2.1 Specifications and standards. The following specifications and standards form a part of this document to the extent specified herein. Unless otherwise specified, issues of these documents are listed in the ASSIST data base (<https://assist.daps.dla.mil>.) and supplement thereto, cited in the solicitation (see [6.2b](#)).

SPECIFICATIONS

DEPARTMENT OF DEFENSE

MIL-PRF-28001	Markup Requirements and Generic Style Specification for Electronic Printed Output and Exchange of Text
----------------------	--

E.2.3 Non-government publications.

INTERNATIONAL ORGANIZATION FOR STANDARDIZATION

ISO 8879 (DoD adopted)	Information Processing - Text and Office Systems - Standard Generalized Markup Language (SGML)
-------------------------------	--

(Copies of these documents are available online at <http://www.iso.org/iso/home.html> or from the Standardization Document Order Desk, 700 Robbins Avenue, Building 4D, Philadelphia, PA 19111-5094.)

E.3 DIGITAL SUPPORT SUITES.

E.3.1 SGML document type definition. Data to be delivered digitally in accordance with this specification shall be tagged using the FI manual DTD found at the TMSS website (see [A.4.1](#)). This DTD provides the structure and content in accordance with the detail specification. The procedure for accomplishing this is found in MIL-PRF-28001 and ISO 8879.

E.3.2 Tag Description Table. The Tag Description Table (TDT) provides detailed descriptions of the elements contained in the FI manual DTD. The TDT contains the following: The element tagging structure, full element name, tag minimization requirements, element structure, reference elements, source paragraph, and attribute descriptions unique to the element. See [A.4.1](#) for information on obtaining this file in digital format.

E.3.3 Attribute Description Table. The Attribute Description Table (ATD) provides detailed descriptions of the attributes contained in the FI manual DTD. See [A.4.1](#) for information on obtaining this file in digital format.

E.4 OBTAINING DSS FILES.

E.4.1 Obtaining DSS files. See [A.4.1](#) for information on obtaining this file in digital format.

**MIL-DTL-83495C (USAF)
W/AMENDMENT 1**

**APPENDIX F
Wiring Diagram (WD) Manual
DOCUMENT TYPE DEFINITION (DTD) SUBSET**

F.1 SCOPE.

F.1.1 Scope. DTDs are based on rules outlined in MIL-PRF-28001, and ISO 8879. The DTD subset referenced within this appendix provides the structure and content of documents prepared in accordance with this detail specification. For digital copies of the DTD, Tag Description Table, and the Attribute Description Table, see [A.4.1](#). This appendix is a mandatory part of this detail specification. The information herein is intended for compliance.

F.2 APPLICABLE DOCUMENTS.

F.2.1 General. The documents listed in this section are specified in sections 3, 4, or 5 of this specification. This section does not include documents cited in other sections of this specification or recommended for additional information or as examples. While every effort has been made to ensure the completeness of this list, document users are cautioned that they must meet all specified requirements of documents cited in sections 3, 4, or 5 of this specification, whether or not they are listed.

F.2.2 Government Documents.

F.2.2.1 Specifications and standards. The following specifications and standards form a part of this document to the extent specified herein. Unless otherwise specified, issues of these documents are listed in the ASSIST data base (<https://assist.daps.dla.mil>.) and supplement thereto, cited in the solicitation (see [6.2b](#)).

SPECIFICATIONS

DEPARTMENT OF DEFENSE

MIL-PRF-28001

Markup Requirements and Generic Style Specification for
Electronic Printed Output and Exchange of Text

F.2.3 Non-government publications.

INTERNATIONAL ORGANIZATION FOR STANDARDIZATION

ISO 8879 (DoD adopted)

Information Processing - Text and
Office Systems - Standard Generalized
Markup Language (SGML)

(Copies of these documents are available online at <http://www.iso.org/iso/home.html> or from the Standardization Document Order Desk, 700 Robbins Avenue, Building 4D, Philadelphia, PA 19111-5094.)

F.3 DIGITAL SUPPORT SUITES.

The following comprise the tools contained in the Digital Support Suite (DSS) used for authoring and rendering the GE manual doc type.

F.3.1 Document Type Definition. Data to be delivered digitally in accordance with this specification shall be tagged using the WD manual DTD found at the TMSS website (see [A.4.1](#)). This DTD provides the structure and content in accordance with the detail specification. The procedure for accomplishing this is found in MIL-PRF-28001 and ISO 8879.

F.3.2 Tag Description Table. The Tag Description Table (TDT) provides detailed descriptions of the elements contained in the WD manual DTD. The TDT contains the following: The element tagging structure, full element name, tag minimization requirements, element structure, reference elements, source paragraph, and attribute descriptions unique to the element. See [A.4.1](#) for information on obtaining this file in digital format.

F.3.3 Attribute Description Table. The Attribute Description Table (ATD) provides detailed descriptions of the attributes contained in the WD manual DTD. See [A.4.1](#) for information on obtaining this file in digital format.

F.4 OBTAINING DSS FILES.

F.4.1 Obtaining DSS files. See [A.4.1](#) for information on obtaining this file in digital format.

**MIL-DTL-83495C (USAF)
W/AMENDMENT 1**

**APPENDIX G
Schematic Diagram (SD) Manual
DOCUMENT TYPE DEFINITION (DTD) SUBSET**

G.1 SCOPE.

G.1.1 Scope. DTDs are based on rules outlined in MIL-PRF-28001, and ISO 8879. The DTD subset referenced within this appendix provides the structure and content of documents prepared in accordance with this detail specification. For digital copies of the DTD, Tag Description Table, and the Attribute Description Table, see [A.4.1](#). This appendix is a mandatory part of this detail specification. The information herein is intended for compliance.

G.2 APPLICABLE DOCUMENTS.

G.2.1 General. The documents listed in this section are specified in sections 3, 4, or 5 of this specification. This section does not include documents cited in other sections of this specification or recommended for additional information or as examples. While every effort has been made to ensure the completeness of this list, document users are cautioned that they must meet all specified requirements of documents cited in sections 3, 4, or 5 of this specification, whether or not they are listed.

G.2.2 Government Documents.

G.2.2.1 Specifications and standards. The following specifications and standards form a part of this document to the extent specified herein. Unless otherwise specified, issues of these documents are listed in the ASSIST data base (<https://assist.daps.dla.mil>.) and supplement thereto, cited in the solicitation (see [6.2b](#).)

SPECIFICATIONS

DEPARTMENT OF DEFENSE

MIL-PRF-28001 Markup Requirements and Generic Style Specification for
Electronic Printed Output and Exchange of Text

G.2.3 Non-government publications.

INTERNATIONAL ORGANIZATION FOR STANDARDIZATION

ISO 8879 (DoD adopted) Information Processing - Text and
Office Systems - Standard Generalized
Markup Language (SGML)

(Copies of these documents are available online at <http://www.iso.org/iso/home.html> or from the Standardization Document Order Desk, 700 Robbins Avenue, Building 4D, Philadelphia, PA 19111-5094.)

G.3 DIGITAL SUPPORT SUITES.

The following comprise the tools contained in the Digital Support Suite (DSS) used for authoring and rendering the GE manual doc type.

G.3.1 Document Type Definition. Data to be delivered digitally in accordance with this specification shall be tagged using the GE manual DTD found at the TMSS website (see [A.4.1](#)). This DTD provides the structure and content in accordance with the detail specification. The procedure for accomplishing this is found in MIL-PRF-28001 and ISO 8879.

G.3.2 Tag Description Table. The Tag Description Table (TDT) provides detailed descriptions of the elements contained in the GE manual DTD. The TDT contains the following: The element tagging structure, full element name, tag minimization requirements, element structure, reference elements, source paragraph, and attribute descriptions unique to the element. See [A.4.1](#) for information on obtaining this file in digital format.

G.3.3 Attribute Description Table. The Attribute Description Table (ATD) provides detailed descriptions of the attributes contained in the GE manual DTD. See [A.4.1](#) for information on obtaining this file in digital format.

G.4 OBTAINING DSS FILES

G.4.1 Obtaining DSS files. See [A.4.1](#) for information on obtaining this file in digital format.

**MIL-DTL-83495C (USAF)
W/AMENDMENT 1**

INDEX

A

Acquisition requirements.....	23
Additional circuit breaker listing.....	18
Additional data.....	14
Alpha identifier.....	19
Applicability.....	13, 21–22
Applicability codes.....	3
Arrangement.....	4, 12
Attribute description table.....	41, 43
Attribute Description Table.....	45–49

B

Basic fault.....	24
Basic procedures.....	20
Blank aprons.....	11

C

Cables.....	7
Changes from previous issue.....	26
Chapter 00, general equipment description.....	5
Chapter 1 general.....	21
Chapter 1, general.....	22
Chapter 1, theory of operation.....	9
Chapter 13, equipment storage.....	5
Chapter 15, support equipment.....	6
Chapter 16, siting installation.....	6
Chapter 17, preparation for use and shipment.....	7
Chapter 18, weapons instrumentation.....	8
Chapter 19, training equipment.....	8
Chapter 2 and subsequent, schematic diagrams.....	22
Chapter 2, equipment list.....	21
Chapter 2, special tools, test equipment and consumables.....	9
Chapter 3, system peculiar maintenance.....	10
Chapter 3, wire harness and connection lists.....	21
Chapter 4 and subsequent, wiring diagrams.....	21
Chapter 6, dimensions and areas, chapter 11 placards and markings.....	5
Chapter table of contents.....	17
Chapters.....	5, 9, 12, 17
Chapters 1, 2, 3, and 4, reserved.....	5
Chapters 5 and 8.....	5
Chapters 7, 9, 10, and 12.....	5
Checklist requirements (Optional).....	14
Circuit breaker listing.....	18
Classified material.....	3, 8
Combined GS manual.....	9
Combined manual.....	25
Compliance.....	22
Component.....	24
Consumable materials.....	24
Consumables.....	14
Content and arrangement.....	17

**MIL-DTL-83495C (USAF)
W/AMENDMENT 1**

Cross reference.....	12
----------------------	----

D

Data accessing system.....	21–22
Definitions.....	24
Depth of coverage.....	18
Detail.....	1
Diagram references (electrical and mechanical).....	20
Diagrams.....	2
Document type definition.....	41, 43
Document Type Definition.....	45–46, 48–49

E

Equipment storage arrangement.....	6
Extended storage.....	6

F

Fault code location.....	20
Fault codes.....	19
Fault groups.....	18
Fault Identification.....	18
Fault isolation (FI) and fault reporting (FR) manuals.....	25
Fault isolation information.....	19
Fault location codes.....	18
Fault reporting (FR) and fault isolation (FI) manuals.....	16
Faults.....	24
FI manual numbering.....	17
Foldout pages.....	2
Foldouts.....	11
Follow-on maintenance.....	15, 24
Foreword.....	5, 9, 12
Format.....	11, 22
FR manual numbering.....	16
Front matter.....	5, 9, 12, 17, 21–22
Function number.....	3
Function number requirements for JG manuals.....	3
Functions.....	12

G

General.....	1, 41, 43, 45–49
General equipment (GE) manual.....	4, 25
General requirements.....	2, 10, 16
General system (GS) manual.....	8, 25
General systems arrangement.....	8
Government documents.....	41, 43
Government Documents.....	46–49
Government documents.....	1, 45

H

Higher level designator (HLD).....	24
------------------------------------	----

**MIL-DTL-83495C (USAF)
W/AMENDMENT 1**

I

Illustrated panel indicators.....	18
Illustrations	15
Index of effective diagrams	22
Initial results	20
Input conditions	13
Installation requirements.....	7
Installation sequence.....	7
Intended use.....	23

J

JG index manual	16
JG manual	10
Job guide (JG) manual	25

L

Level	20
Levels.....	22
Line replaceable unit (LRU).....	24
List of consumable materials	10
Location of parts	19
Log book reports.....	19

M

Maintenance actions.....	20
Maintenance function.....	24
Maintenance procedure.....	24
Maintenance step	24
Maintenance task	24
Manual form.....	16
Marginal copy	2
Material handling equipment.....	7
Multi-person requirements.....	14
Multiple item faults.....	20

N

Nomenclature.....	11, 25
Nomenclature requirements.....	2
Nomenclatures and abbreviations.....	17
Non-government publications.....	41, 43, 45-49
Non-Government publications.....	1
Numbering	2, 8, 11

O

Obtaining DSS files	44-49
Obtaining DSS files with a .mil address	42
Obtaining files without a .mil address	42
Official nomenclature.....	25
On-Equipment maintenance.....	25
On-equipment maintenance manual set.....	25
Operating limits	19
Order of precedence.....	1
Other government documents, drawings and publications.....	1

**MIL-DTL-83495C (USAF)
W/AMENDMENT 1**

P

Packaging requirements.....	23
Page size.....	4
Panel indicators.....	18
Personnel recommended.....	14
Preparation requirements.....	2
Procedural guidelines.....	18
Procedures.....	20
Purpose.....	22

R

References.....	4
Related manuals.....	25
Repeated sequence of tasks.....	25
Repeated task/sequence.....	25
Required conditions.....	13
Required equipment list.....	7
Required storage equipment.....	6
Requirement for assistance.....	25

S

Safety conditions.....	14
Safety summary.....	12
Schematic diagram (SD) manual.....	25
Schematic diagrams (SD) manual.....	21
Scope.....	1, 4, 8, 10, 16, 41, 43, 45-49
Section I, installation logistics.....	7
Section I, preparation for use.....	7
Section II, installation procedures.....	7
Section II, preparation for shipment.....	8
Sequence.....	19
SGML document type definition.....	47
Short form use of common names.....	2
Single entry fault.....	24
Size.....	8, 11
Spacing.....	20
Special notations.....	18
Special tools and test equipment list.....	10
Specific fault codes.....	18
Specifications and standards.....	41, 43, 45-49
Specifications, standards, and handbooks.....	1
Standard nomenclature.....	25
Style of writing.....	11
Sub-subsystem numbering.....	3
Subfault.....	24
Subject number development for other than JG, FR and FI manuals.....	3
Subject term (key word) listing.....	26
Subsystem and sub-subsystems.....	19
Supplemental data.....	20
Support equipment.....	14
Syntax.....	11
Systems covered.....	8

**MIL-DTL-83495C (USAF)
W/AMENDMENT 1**

T

Table of contents.....	12
Tag description table.....	41, 43
Tag Description Table.....	45-49
Task/component number development for JG, FR and FI manuals.....	3
Task/component number numbering.....	3
Tasks.....	15
Technical manuals.....	24
Temporary storage.....	6
Terminology.....	2
Text.....	15
TMSS support.....	42
Tolerances.....	11
Traceability.....	20
Typical functions.....	3

U

Unit identification.....	20
Unloading and unpacking.....	7
Use of "Subsystem" number.....	2
Use of "System" number.....	2
Use of SSSN.....	2

V

Verification requirements.....	22
--------------------------------	----

W

Wiring data (WD) manual.....	21, 25
Wording.....	20

**MIL-DTL-83495C (USAF)
W/AMENDMENT 1**

CONCLUDING MATERIAL

Custodians:
Air Force - 16

Preparing activity:
Air Force - 16
(Project TMSS-2011-002)

Review activities:
Air Force - 01, 11, 13, 19

NOTE

The activities listed above were interested in this document as of the date of this document. Since organizations and responsibilities can change, you should verify the currency of the information above using the ASSIST Online database at <https://assist.daps.dla.mil>.