

INCH-POUND

MIL-DTL-83420J
21 December 2000
SUPERSEDING
MIL-DTL-83420H
30 October 1999

DETAIL SPECIFICATION

WIRE ROPE, FLEXIBLE, FOR AIRCRAFT CONTROL

This specification is approved for use by all Departments and Agencies of the Department of Defense.

1. SCOPE

1.1 Scope. This specification covers the requirements for carbon steel and corrosion resistant steel aircraft control flexible wire rope. The wire rope, type I should be capable of operation within a -54 °C to +121 °C (-65 °F to +250 °F) temperature range in wind, dust, fuel and oil spills, in wash-down and other environmental stresses and aircraft experiences. Type II wire rope should be capable of operation within a -54 °C to +94 °C (-65 °F to +200 °F) temperature range in wind, dust, fuel and oil spills, in wash-down and other environmental stresses and aircraft experiences.

1.2 Classification. The wire rope should be furnished in the following types and compositions as specified (see 6.2).

1.2.1 Type. The type of wire rope should be as follows:

Type I - Nonjacketed wire rope

Type II - Jacketed wire rope

1.2.2 Composition. The composition of the wire rope should be as follows:

Composition A - Carbon steel, zinc or tin over zinc coated

Composition B - Corrosion resistant steel

Beneficial comments (recommendations, additions, deletions) and any pertinent data which may be of use in improving this document should be addressed to: Defense Supply Center Richmond, ATTN: DSCR-VBD, Richmond, VA 23297-5610, by using the Standardization Document Improvement Proposal (DD Form 1426) appearing at the end of this document or by letter.

AMSC N/A

FSC 4010

DISTRIBUTION STATEMENT A. Approved for public release; distribution is unlimited.

MIL-DTL-83420J

2. APPLICABLE DOCUMENTS

2.1 General. The documents listed in this section are specified in sections 3 and 4 of this specification. This section does not include documents cited in other sections of this specification or recommended for additional information or as examples. While every effort has been made to ensure the completeness of this list, document users are cautioned that they must meet all specified requirements and documents cited in sections 3 and 4 of this specification, whether or not they are listed.

2.2 Government documents:

* 2.2.1 Specifications, standards, and handbooks. The following specifications, standards, and handbooks form a part of this document to the extent specified herein. Unless otherwise specified, the issues of these documents are those listed in the issue of the Department of Defense Index of Specifications and Standards (DoDISS) and supplement thereto, cited in the solicitation (see 6.2).

SPECIFICATIONS

DEPARTMENT OF DEFENSE

MIL-A-8243	- Anti-icing and Deicing-Defrosting Fluids.
MIL-DTL-781	- Terminal; Wire Rope Swaging.
MIL-DTL-5624	Turbine Fuel, Aviation, Grades JP-4 and JP-5, and JP-5/JP-8 ST.
MIL-DTL-83420/1	- Wire Rope, Flexible, Type I, Composition A.
MIL-DTL-83420/2	- Wire Rope, Flexible, Type I, Composition B.
MIL-DTL-83420/3	- Wire Rope, Flexible, Type II (Jacketed), Composition A.
MIL-DTL-83420/4	- Wire Rope, Flexible, Type II (Jacketed), Composition B.
MIL-H-5606	- Hydraulic Fluid, Petroleum Base; Aircraft, Missile, and Ordnance.
MIL-H-19457	- Hydraulic Fluid, Fire-Resistant, Non-Neurotoxic.
MIL-PRF-7808	- Lubricating Oil, Aircraft Turbine Engine, Synthetic Base.
MIL-PRF-87937	- Cleaning Compound, Aerospace Equipment.
MIL-PRF-83282	- Hydraulic Fluid, Fire Resistant, Synthetic Hydrocarbon Base, Metric, NATO Code Number H-537.

STANDARDS

DEPARTMENT OF DEFENSE

MIL-STD-129	- Military Marking.
-------------	---------------------

MIL-DTL-83420J

(Unless otherwise indicated, copies of the above specifications and standards are available from the Standardization Documents Order Desk, 700 Robbins Avenue, Building 4D, Philadelphia, PA 19111-5094.)

* 2.3 Non-Government publications. The following document(s) form a part of this document to the extent specified herein. Unless otherwise specified, the issues of the documents which are DoD adopted are those listed in the issue of the DoDISS cited in the solicitation. Unless otherwise specified, the issues of documents not listed in the DoDISS are the issues of the documents cited in the solicitation (see 6.2).

AMERICAN SOCIETY FOR TESTING AND MATERIALS (ASTM)

- | | |
|------------|--|
| ASTM A 90 | - Standard Test Method for Weight [Mass] of Coating on Iron or Steel Articles with Zinc or Zinc-Alloy Coatings. (DoD adopted). |
| ASTM B 246 | - Standard Specification for Tinned Hard-Drawn and Medium-Hard-Drawn Copper Wire for Electrical Purposes (DoD adopted). |
| ASTM D 570 | - Standard Test Method for Water Absorption of Plastics (DoD adopted). |
| ASTM D 635 | - Standard Test Method for Rate of Burning and/or Extent and Time of Burning of Plastics in a Horizontal Position (DoD adopted). |
| ASTM D 638 | - Standard Test Method for Tensile Properties of Plastics (DoD adopted). |
| ASTM D 648 | - Standard Test Method for Deflection Temperature of Plastics Under Flexural Load in the Edgewise Position (DoD adopted). |
| ASTM D 746 | - Standard Test Method for Brittleness Temperature of Plastics and Elastomers by Impact (DoD adopted). |
| ASTM D 747 | - Standard Test Method for Apparent Bending Modulus of Plastics by Means of a Cantilever Beam (DoD adopted). |
| ASTM D 789 | - Standard Test Methods for Determination of Relative Viscosity and Moisture Content of Polyamide (PA). |
| ASTM D 792 | - Standard Test Methods for Density and Specific Gravity (Relative Gravity) of Plastics by Displacement (DoD adopted). |
| ASTM D 910 | - Standard Specification for Aviation Gasolines (DoD adopted). |
| ASTM E 8 | - Standard Test Methods for Tension Testing of Metallic Materials (DoD adopted). |

(Application for copies should be addressed to the American Society for Testing and Materials, 100 Barr Harbor Drive, West Conshohocken, PA 19428-2959.)

SOCIETY OF AUTOMOTIVE ENGINEERS, INC.

- | | |
|-------------|---|
| SAE HS-1086 | - Metals and Alloys in the Unified Number System (DoD adopted). |
|-------------|---|

MIL-DTL-83420J

(Application for copies should be addressed to the Society of Automotive Engineers, Inc., 400 Commonwealth Drive, Warrendale, PA 15096.)

2.4 Order of precedence. In the event of a conflict between the text of this document and the references cited herein (except for related associated detail specifications, or specification sheets), the text of this document takes precedence. Nothing in this document however, supersedes applicable laws and regulations unless a specific exemption has been obtained.

3. REQUIREMENTS

3.1 Specification sheets. The individual item requirements shall be as specified herein and in accordance with the applicable specification sheet. In the event of any conflict between the requirements of this specification and the specification sheet, the latter shall govern. (If a specific requirement specified herein is not required for an item, it shall be so indicated on the specification sheet; for example, "Shock-N/A").

* 3.2 Qualification. Wire rope (see 6.4.15) furnished under this specification shall be products that are qualified for listing on the applicable qualified products list at the time of award of contract (see 4.2 and 6.3). Products must be qualified by a test facility located in the continental United States or Canada (see 4.1).

3.2.1 Wire rope for type II. The wire rope that is to be nylon jacketed to form type II must be qualified as type I, composition A or B wire rope in accordance with the provisions of this specification.

* 3.2.2 Once a type I wire rope is subjected to subsequent processing for qualification or manufacture as a type II wire rope, it shall not be certified or shipped as a type I wire rope.

3.2.3 Type II wire rope shall not be reprocessed into type I wire rope.

3.3 Materials and protective coating.

3.3.1 Steel for composition A. Carbon steel shall be used for composition A wire rope and shall be of one type. The carbon steel shall be capable of meeting the requirements of this specification.

3.3.2 Steel for composition B. Corrosion resistant steel S30200 or S30400 in accordance with SAE HS-1086 shall be used for composition B, types I and II wire rope.

3.3.3 Protective coating. Composition A wires shall be thoroughly and uniformly coated by the methods specified in 3.3.3.1 or 3.3.3.2.

MIL-DTL-83420J

3.3.3.1 Zinc coating for composition A. Zinc coating of composition A wires shall be by the hot dipped or electroplated process and shall conform to the following:

<u>Wire Diameter</u>	<u>Minimum Weight of Zinc Coating (oz./sq. ft.)</u>
.005 to .010 inch	.03
Over .010 to .015 inch	.05
Over .015 to .028 inch	.10
Over .028 to .060 inch	.20

3.3.3.2 Tin coating for composition A. Tin coating over zinc of composition A wires shall be by the hot-dipped or electroplated process and shall conform to the following:

<u>Wire Diameter</u>	<u>Minimum Weight of Tin Coating (oz./sq. ft.)</u>
.005 to .010 inch	.003
Over .010 to .015 inch	.005
Over .015 to .028 inch	.010
Over .028 to .060 inch	.015

3.3.3.3 Nylon jacketed coating for type II. The nylon jacketing (see 6.4.2) material shall meet the requirements of this specification as specified in 3.3.3.3.1 and shall be extruded over the rope. Only virgin nylon material shall be used in coating on type II wire rope.

3.3.3.3.1 Nylon jacketing physical and mechanical properties. The nylon used on the wire rope shall be in accordance with ASTM D 789 and capable of meeting the requirements listed below when tested in accordance with the following test methods:

<u>Property</u>	<u>Requirement (Test Method)</u>
Ultimate tensile strength	5,000 psi minimum (4.5.1)
Elongation	250 percent minimum (4.5.1)
Specific gravity	.95 to 1.09 (4.5.2)
Stiffness	35,000 psi minimum (4.5.5)
Water absorption	1.5 percent maximum (4.5.3)
Brittleness	-54 °C (-65 °F) maximum (4.5.4)
Heat deflection	100/35 °C at 66/264 psi minimum (4.5.6)
Melting range	160 ° to 190 °C (320 °F to 364 °F) (4.5.7)
Burn resistance	4 inch/minimum (4.5.8)

* 3.3.4 Lubricant. Each wire of the wire rope shall be coated with a friction-preventative non-corrosive lubricant. As a minimum the lubricant shall be capable of operating at temperatures from -54 °C to +121 °C (-65 °F to +250 °F).

MIL-DTL-83420J

3.4 Construction.

* 3.4.1 Wire. The wire (see 6.4.14) used in steel wire rope cable shall be cylindrical, smooth and of uniformly high quality.

3.4.1.1 Wire properties. Tensile strengths of wire and wire sizes shall be such that wire rope will be capable of meeting the requirements of this specification.

3.4.1.2 Preforming (see 6.4.8) of wires and strands. The individual wires and strands composing the wire rope shall be shaped into the exact helical position they will have in the finished wire rope, so that if the wire rope is cut or severed there is no tendency for the measured diameter of the wire rope at the unseized cut ends to increase by more than the amount specified in table I.

* 3.4.1.3 Splicing and joining. All splices or joints in wires less than .008 inch may be longitudinally twisted. All wire sizes of .008 inch or more shall be brazed or welded. Any joints in individual wires in any layer of a strand (see 6.4.11) shall not be closer than 20 feet except as specified in 3.4.1.3.1 (see 4.5.2).

* 3.4.1.3.1 Twist-off. When a twist-off (see 6.4.13) occurs during fabrication of the 7-wire layer of a 19-wire strand (see 3.4.1.3), splices and joints in individual wires may be as close as 18 inches.

3.4.2 Wire rope lengths. The wire rope shall be furnished on reels in lengths specified by the procuring activity. There will be no more than two pieces of wire rope on the reel. The shortest piece shall be a minimum of 20 percent of the reel length. The distance to the break point on the reel shall be marked on the reel and package (see 3.6.3).

3.4.3 Types of construction. Flexible steel wire rope shall be 3 x 7, 7 x 7, or 7 x 19 construction and shall be regular lay (see 6.4.9) for the respective diameters, the dimensional tolerances, and the physical properties as specified in tables I and II.

* 3.4.3.1 Construction 3 x 7. Wire rope of this construction shall consist of 3 strands of 7 wires each laid together without a core. Each strand shall consist of a layer of 6 wires laid around a center wire (see 6.4.1) in a left-hand direction. The 3 strands shall be laid together in a right-hand direction. The length of lay (see 6.4.3 and 6.4.4) of the 6 outer wires in each strand shall not exceed 70 percent of the lay of the finished rope. The length of lay of the finished wire rope shall not be more than 7 nor less than 5 times the nominal wire rope diameter (see 6.4.16).

* 3.4.3.2 Construction 7 x 7. Wire rope of this construction shall consist of 6 outer strands of 7 wires each laid around a strand core (see 6.4.12) of 7 wires. The 6 outer strands shall consist of a layer of 6 wires laid around a center wire in a left-hand direction. The strand core shall consist of a layer of 6 wires laid around a center wire in a right-hand direction. The 6 outer strands shall be laid around the core in a right-hand direction. The length of lay of the outside 6 wires in each of the 6 outside strands and the outside 6 wires of the strand core shall not exceed

MIL-DTL-83420J

60 percent of the lay of the finished wire rope. The length of the lay of the finished wire rope shall be not more than 8 nor less than 6 times the nominal rope diameter.

3.4.3.3 Construction 7 x 19. Wire rope of this construction shall consist of 6 outer strands of 19 wires each laid around a strand core of 19 wires. The 6 outer strands shall each consist of a layer of 6 wires laid around a center wire in a left-hand direction and a layer of 12 wires laid over the 7-wire strand in a left-hand direction. The strand core shall consist of a layer of 6 wires laid around a center wire in a right-hand direction and a layer of 12 wires laid around the 7-wire strand in the right-hand direction. The 6 outer strands shall be laid around the core in a right-hand direction. The length of lay of the inside layer of 6 wires in each of the 6 outer strands and the one strand core shall not exceed 60 percent of the outside layer of 12 wires in each strand. The length of lay of the outside layer of 12 wires in each of the 6 outside strands and the strand core shall not exceed 50 percent of the lay of the finished wire rope. The length of the lay of the finished wire rope shall not be more than 8 nor less than 6 times the nominal rope diameter.

3.5 Performance.

3.5.1 Operating range. The wire rope shall be capable of operation in wind, dust, fuel, oil spills, wash-down and other aircraft environmental stresses and experiences at the temperature ranges specified in paragraphs 3.5.1.1 and 3.5.1.2.

3.5.1.1 Type I wire rope shall be capable of operating within a -54 °C to +121 °C (-65 °F to +250 °F) temperature range.

3.5.1.2 Type II wire shall be capable of operating within a -54 °C to +94 °C (-65 °F to +200 °F) temperature range.

3.5.2 Wire flexibility.

3.5.2.1 Ductility of steel. Composition A or B wire shall not fracture when wrapped in accordance with 4.4.1.1 prior to wire rope fabrication.

3.5.2.2 Adherence of coating. The tin or zinc coating shall not crack or flake when wrapped in accordance with 4.4.1.2 prior to wire rope fabrication. Loosening or detachment of small superficial particles of coating (formed by mechanical polishing of the surface) during the adhesion test is acceptable.

3.5.3 Breaking strength. The type I, compositions A and B wire ropes shall have the minimum breaking strength as shown in table I.

3.5.4 Endurance, type I wire rope. Each wire rope size of each construction shall be capable of withstanding the respective tension loads and reversals shown in table III.

MIL-DTL-83420J

3.5.5 Endurance, type II wire rope. Each wire rope size of each construction shall be capable of withstanding the respective tension loads and reversals shown in table IV. There shall be no cracking or deterioration of the nylon coating after the test.

3.5.6 Stretch limits. The stretch in each wire rope size of each construction shall not exceed 1.5 percent when it is loaded to 60 percent of the minimum breaking strength as shown in table I.

3.5.7 Test load. Each wire rope size of each construction shall carry 80 percent of its respective minimum breaking strength load, as shown in table I, without any failures of the individual wires in the rope.

3.5.8 Jacket characteristics, type II. The nylon jacketed wire rope shall have characteristics in accordance with the requirements of table II.

3.5.9 Low temperature flexibility, type II. Each size of each type II jacketed rope shall be bent or flexed at a temperature of -54 °C (-65 °F) without any deleterious effects such as cracking of the nylon or separation from the wire rope.

3.5.10 Resistance to fluids. Type II wire rope shall show no deleterious effects when immersed in the fluids listed in 4.4.10.

3.6 Identification of product. The wire rope shall be identified in accordance with the following:

3.6.1 Identification by number. Each manufacturer shall assign a significant identification number on each manufacturing reel of wire rope. When the wire rope on the manufacturing reel is cut to specified lengths for transfer to the shipping reel (see 6.4.10), each shipping reel shall be marked with the identification number of the manufacturing reel.

3.6.2 Identification by color tracer filament. Each manufacturer shall identify every wire rope made to this specification by the use of color tracer filaments manufactured into the rope. The specification preparing activity shall assign a combination of two colors to each manufacturer desiring qualification. The inclusion of color tracing filaments does not signify that the wire rope is in full conformance, but only serves to identify the manufacturer. Color tracer filaments are not mandatory in 3 x 7 construction.

3.6.3 Identification of reels and shipping containers. Each shipping reel and shipping container shall be marked in accordance with the requirements of MIL-STD-129. The following information shall be included:

- a. Stock No. or identification as specified in the contract. 1/
- b. Size (include diameter of wire rope, outside diameter of nylon).
- c. Name of wire rope manufacturer.
- d. Name of contractor.

MIL-DTL-83420J

- * e. Contractor order number.
- f. Type of wire rope, composition, protective coating for composition A, and specification number (MIL-DTL-83420).
- g. Date of manufacture (month/year).
- h. For reels with 2 lengths of wire rope, record distance from outside end to separation point and total length of wire rope on the reel.
- i. Manufacturing reel/lot number.
- 1/ The contractor shall enter the National Stock Number (NSN) specified in the contract or as furnished by the procuring activity. Space shall be left for the NSN when not available.

3.7 Workmanship and finish. All details of workmanship and finish shall be in accordance with the best practice for high quality aircraft wire rope consistent with the requirements of this specification. The finished cable shall be uniform in construction and securely laid, free from kinks, loose wires, loose strands, or other defects (see 4.4.2). Protruding wires are considered a defect and not more than one broken wire will be accepted in 1000 feet of wire rope.

3.7.1 Physical appearance, type II. The nylon jacket shall be uniform in outside diameter (O.D.) and in wall thickness as specified in table II and shall be uniform in appearance. The nylon jacket shall be translucent and shall be homogeneous and uniform in consistency. The jacketed wire rope shall have no cracks or seams, or foreign material in the nylon on the surface. Any deleterious effects, such as cracking or separating from the wire rope, shall be cause for rejection.

3.7.1.1 Concentricity. The differences in wall thickness as determined in 4.4.2.1 shall not exceed 20 percent.

4. VERIFICATION

4.1 Classification of inspection. The inspection and testing of the wire rope shall be classified as follows:

- a. Qualification inspection (see 4.2).
- b. Quality conformance inspection (see 4.3).

4.2 Qualification inspection.

4.2.1 Qualification inspection samples. When conducting qualification tests specified herein, one sample lot for each size and construction of wire rope listed in tables I and II, for which qualification is desired, shall be taken after any discard has been removed from the head or starting end of the first manufacturing reel for each lot of wire rope.

4.2.1.1 Lot. A qualification inspection lot shall consist of 50 feet of wire rope of the same construction and diameter produced continuously by one machine or by one series of progressive processing machines.

MIL-DTL-83420J

4.2.2 Qualification testing. Qualification tests shall be performed for each size and construction of wire rope for which qualification is desired as specified in table V.

4.2.3 Qualification for type II. Qualification for type II wire rope shall be finalized after the following:

* a. Receipt from the nylon manufacturer of a test report that includes, as a minimum, the results of the tests specified in 4.5.

b. Successful completion of the remaining qualification tests for type II wire rope.

* 4.2.3.1 Duplication nylon certification. If two or more type II wire rope sizes are submitted for qualification, and the nylon coating is of the same type and grade, copies of the original test certification on the particular type and grade of nylon will satisfy the requirement as specified in 4.2.3 and 4.3.4.

4.2.4 Retention of qualifications. To retain qualification, the manufacturer must be able to demonstrate that the company still has the capabilities and facilities necessary to produce the items. The qualifying activity will request appropriate documentation demonstrating this capability at the time qualification retention is required (at least 2 year intervals).

4.3 Quality conformance inspection. Quality conformance inspection shall consist of individual tests and sampling tests.

* 4.3.1 Individual tests. Each size wire rope of each type, composition and construction furnished under each government order or contract shall be subject to the following tests as described under 4.4 (see table V):

- a. Ductility of steel (4.4.1.1).
- b. Adherence of coating (4.4.1.2).
- c. Examination of product (4.4.2).
- d. Concentricity tests for type II wire rope (4.4.2.1).
- e. Conformance test to preforming of cable (4.4.2.2).
- f. Color-coding identification (4.4.11).

4.3.2 Sampling plan.

4.3.2.1 Sample.

4.3.2.1.1 Wire rope. When conducting the sampling tests specified herein, one sample not less than 50 feet in length shall be taken after any discard has been removed from the head or starting end of the first manufacturing reel for each lot of wire rope.

4.3.2.1.2 Wire. When conducting the sampling tests specified herein, one random sample of wire, of sufficient length to meet testing requirements, shall be taken from the wire lot.

MIL-DTL-83420J

4.3.2.2 Lot.

4.3.2.2.1 Wire rope. A lot shall consist of not more than 20,000 feet of wire rope of the same construction and diameter produced continuously by one machine or by one series of progressive processing machines.

4.3.2.2.2 Wire. A lot shall consist of wire of one size produced from the same heat of steel in one continuous process.

4.3.2.3 Specimen. A specimen is a section of wire rope or wire cut from a sample for the performance of a testing method. All specimens shall be taken from the lot furnished under that specific order.

4.3.3 Sampling tests. The quality conformance sampling tests shall be performed in accordance with the paragraphs listed in table V.

* 4.3.4 Certification. For each government order or contract, the wire rope manufacturer shall certify that the product satisfactorily passed the quality conformance inspections (see 4.3.1 and 4.3.3) of this specification. The certification shall include, as a minimum, actual results of the tests specified herein and shall be retained on file at the manufacturer's facility for a minimum of 7 years.

* 4.3.5 Nylon certification. For each government order or contract, a certification from the nylon manufacturer shall verify that the nylon meets the requirements of this specification (3.3.3.3 and 3.3.3.3.1) (see 6.3). The certification will be retained on file at the manufacturer's facility for a minimum of 7 years.

4.4 Test methods.4.4.1 Wire flexibility.

4.4.1.1 Ductility of steel. A specimen from the wire sample shall be wrapped in a way which does not cause indenting. The wire shall be wrapped around a cylindrical mandrel for 2 complete turns in a close helix at a rate not exceeding 15 turns per minute. The cylindrical mandrel diameter shall be equal to the nominal wire diameter being tested for composition B, and two times the nominal diameter being tested for composition A.

4.4.1.2 Adherence of coating. A specimen from the tin or zinc coated wire sample shall be capable of being wrapped at a rate not to exceed 15 turns per minute in close helix of at least 2 turns around a cylindrical mandrel equal to 2 times the nominal diameter of the wire under tests without cracking or flaking the tin or zinc coating to such an extent that any tin or zinc can be removed by rubbing with the bare finger.

4.4.2 Examination of product. Each sample of wire rope shall be visually examined for workmanship and finish to determine compliance with 3.7.

MIL-DTL-83420J

4.4.2.1 Concentricity test for type II wire rope. All type II wire rope shall be examined for concentricity as specified in 3.7.1.1. The wall thickness shall be measured 180 degrees apart in two 90 degree planes. The percent variation in wall thickness shall be calculated as follows:

$$\text{Percent variation} = \frac{\text{Difference between the two measurements C and D}}{\text{Smaller of the two measurements}} \times 100 \leq 20\%$$

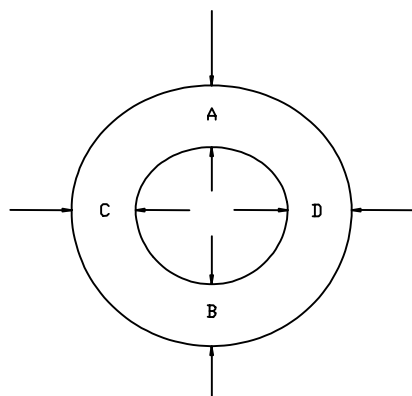

This calculation shall be repeated for dimensions A and B.

4.4.2.2 Conformance test to preforming of wire rope. To test wire rope for conformity to values shown in table I for increase in diameter, the wire rope shall be mechanically cut with a cutter having constricting jaws. A plain shear with straight blades distorts the product and may void the test. After cutting, the wire rope shall be measured by passing the wire rope through a hole drilled to a diameter increased as shown in table I under "Allowable increase in diameter at cut end" or by using a shadowgraph with suitable magnification.

4.4.3 Breaking strength type I, composition A and B. A specimen for each size and construction of wire rope shall be selected from the sample from each lot. The specimen shall be no less than 24 inches in length, and where necessary, swaged terminals conforming to MIL-DTL-781 (do not use ball end fittings) and accompanying hardware may be used to facilitate installation of the specimen in the jaws of the testing machine. The length of wire rope sample under load shall be no less than 10 inches. The breaking strength shall be determined by use of a tensile testing machine in accordance with applicable requirements of ASTM E 8. The breaking strength shall conform to the requirement of table I. In case of failure due to an unsatisfactory end termination, the test will be disregarded and a new test conducted.

* 4.4.4 Endurance testing for type I. The test set-up for the endurance tests, for all type I wire rope shall conform to figure 1. The total travel of the wire rope in one direction shall be 13.5 inches. The test sheaves shall be made of steel and shall conform to the dimensions of figure 2 and the individual wire diameters in table VI. The application of lubricant to the

MIL-DTL-83420J

endurance test sample, in addition to the lubricant applied during the manufacture of wire rope, shall not be permitted either before or during the endurance test.

- * 4.4.4.1 Endurance testing at -54 °C (-65 °F) for type I, composition A. An endurance test at -54 °C (-65 °F) shall be conducted for each type I, composition A wire rope diameter and construction as specified in 4.4.4. The number of reversals and tension loads shall be as indicated in table III. After the endurance test at -54 °C (-65 °F), a test specimen that is that portion of the wire rope that passes over the test sheave during the endurance test shall be subjected to a breaking strength determination as specified in 4.4.3, except the breaking strength shall be equal to or greater than that specified in table III.
- * 4.4.4.2 Endurance test at room temperature for type I, composition A and B. An endurance test at room temperature shall be conducted for each type I composition A and B wire rope diameter and construction as specified in table III. The number of reversals and tension loads shall be as indicated in table III. After the endurance test at room temperature, a test specimen that is that portion of the wire rope that passes over the test sheave during the endurance test shall be subjected to a breaking strength determination as specified in 4.4.3, except the breaking strength shall be equal to or greater than that specified in table III.
- * 4.4.5 Endurance testing for type II. The test set-up for the endurance tests of type II nylon jacketed wire rope shall conform to figure 1. The total travel of the wire rope in one direction shall be 13.5 inches. The test sheaves shall be made of steel and shall conform to the dimensions of figure 2 and the individual wire diameters in table VII which conform to the O.D. size of the nylon coating, and test loads which conform to the wire rope size.
- * 4.4.5.1 Endurance test at -54 °C (-65 °F) for type II, composition A and B. An endurance test at -54 °C (-65 °F) shall be conducted for each type II composition A and B wire rope diameter and construction as specified in table IV. The number of reversals and tension loads shall be as indicated in table IV. After the endurance test at -54 °C(-65 °F), a test specimen that is that portion of the nylon jacketed wire rope that passes over the test sheave during the endurance test shall be subjected to a breaking strength determination as specified in 4.4.5, except the breaking strength shall be equal to or greater than that specified in table IV.
- 4.4.5.2 Endurance test at room temperature for type II, composition A and B. An endurance test at room temperature shall be conducted for each type II composition A and B wire rope diameter and construction as specified in table IV. The number of reversals and tension loads shall be as indicated in table IV. After the endurance test at room temperature a test specimen that is that portion of the nylon jacketed wire rope that passes over the test sheave during the endurance test shall be subjected to a breaking strength determination as specified in table IV, except the breaking strength shall be equal to or greater than that specified in table IV.
- 4.4.6 Stretch test for type I, composition A and B. One specimen from each sample of wire rope selected as specified in 4.4.3 shall be tested to determine the percent stretch. The total length of the wire rope specimen to be tested shall not be less than 24 inches. Where necessary, swaged terminals and accompanying hardware may be used to facilitate installation of the

MIL-DTL-83420J

specimen in the jaws of the test machine. The amount of stretch shall be determined on a tension testing machine in accordance with ASTM E 8. The specimen shall be loaded to one percent minimum breaking strength shown in table I to straighten the wire rope and, while the specimen is under tension, a gauge length not less than 10 inches shall be marked on the wire rope between the end fittings of the testing specimen. The specimen shall then be loaded to 60 percent of minimum breaking strength and measured for elongation under load. From these data, the percent stretch can be calculated using the formula below:

$$\text{Percent stretch} = \frac{\text{Elongation of gauge length under load}}{\text{Original gauge length}} \times 100 \leq 1.5\%$$

4.4.7 Test load for type I, composition A and B. The following test shall be conducted using the same wire rope specimen used in stretch test, or similarly prepared specimen. Load the specimen to one percent of breaking strength and then increase the loading to 80 percent of the minimum required breaking strength of the wire rope specified in table I. The load shall be applied for five seconds. At the end of the test the entire wire rope shall be completely unwound and every wire inspected. A suitable electronic device capable of detecting the breaking of individual wires during testing may be used instead of unwinding the wire rope. The failure of any wire shall be cause for rejection (see 4.4.7.1 and 6.4.7).

4.4.7.1 Use of acoustic, electronic device for first wire break test. The load shall be increased to 80 percent on the test specimen. If no ping (see 6.4.7) is heard, the specimen has passed the test. If one or more pings are heard, the wire rope specimen shall be unraveled and the broken wires shall confirm failure of the specimen. If no broken wires are found, the specimen has passed the test.

4.4.8 Protective coating.

4.4.8.1 Tin or zinc coating, composition A.

4.4.8.1.1 Preparation of specimens. For qualification, three specimens not less than 12 inches long shall be cut from the wire before the wire rope is fabricated. These specimens shall be cut from each size of wire to be used in making each lot of wire rope. Optionally, three 12 inch samples of the wire rope may be cut off and used for specimens.

4.4.8.1.2 Tin-coated wire. The weight of coating on samples of tin-coated wire shall be determined in accordance with ASTM B 246.

MIL-DTL-83420J

4.4.8.1.3 Zinc-coated wire. The weight of coating on samples of zinc-coated wire shall be determined in accordance with ASTM A 90.

4.4.9 Low temperature flexibility for type II, composition A and B. The jacketed wire rope for qualification testing shall be subjected to -54 °C (-65 °F) for a period of 24 hours in a straight position. After this time and while still at the specified temperature, the sample shall be evenly and uniformly bent over a test sheave with the same dimensions as the endurance sheave for the particular size wire rope. Bending shall be accomplished in a period of not less than 8 seconds and not more than 12 seconds, and the wire rope shall be bent at least 180 degrees in the groove of the sheave. After flexing, straighten the wire rope out and allow to warm to room temperature in four to six hours, then examine the flexed area under a magnification of 20 x power. There shall be no evidence of cracks or separation of the nylon jacket from the wire rope.

* 4.4.10 Resistance to fluids on type II, composition A and B. For qualification testing, totally immerse a separate 3-inch unsealed length of nylon jacketed wire rope in each of the fluids listed below for four hours. Remove, wipe dry, and record appearance of each one of the specimens. Deleterious effects such as softening, cracking, or separation shall be cause for rejection. A separate test specimen shall be used for each fluid test.

- | | |
|------------------|---|
| a. MIL-H-5606 | Hydraulic fluid |
| b. MIL-DTL-5624 | Jet fuel JP-4, JP-5, and JP-5/JP-8 ST |
| c. MIL-PRF-7808 | Lubrication oil |
| d. MIL-A-8243 | Anti-icing fluid |
| e. MIL-H-19457 | Hydraulic fluid (skydrol 500A, or equivalent) |
| f. MIL-PRF-87937 | Cleaning compound |
| g. MIL-PRF-83282 | Hydraulic fluid |
| h. ASTM D 910 | Aviation Gasolines |

4.4.11 Color-coding identification. Each wire rope sample shall be inspected for proper identification as specified in 3.6.2.

* 4.5 Nylon testing for type II. The nylon manufacturer shall perform all the tests specified herein to determine compliance with the requirements of 3.3.3.3 herein. The test specimen shall be molded into a shape needed to perform the tests. The nylon jacket extrusion material lot number shall be identified in the molding test report.

4.5.1 Tensile strength, percent elongation. Specimens shall be molded into type 4 test bars and tests shall be conducted in accordance with ASTM D 638.

4.5.2 Specify gravity. Specimens shall be molded and tests shall be conducted in accordance with ASTM D 792.

4.5.3 Water absorption. Specimens shall be molded and tests shall be conducted in accordance with ASTM D 570.

MIL-DTL-83420J

4.5.4 Brittleness. Specimens shall be molded and tests shall be conducted in accordance with ASTM D 746.

4.5.5 Stiffness. Specimens shall be molded and tests shall be conducted in accordance with ASTM D 747.

4.5.6 Heat deflection. Specimens shall be molded and tests shall be conducted in accordance with ASTM D 648.

4.5.7 Melting range. Specimens shall be molded and tests shall be conducted in accordance with ASTM D 789.

4.5.8 Burn resistance. Specimens shall be molded and tests shall be conducted in accordance with ASTM D 635.

4.6 Preparation for delivery. The preservation, packaging, packing and marking shall be examined for conformance to section 5.

5. PACKAGING

5.1 Packaging. For acquisition purposes, the packaging requirements shall be as specified in the contract or order (see 6.2). When actual packaging of material is to be performed by DoD personnel, these personnel need to contact the responsible packaging activity to ascertain requisite packaging requirements. Packaging requirements are maintained by the Inventory Control Point's packaging activity within the Military Department or Defense Agency, or within the Military Department's System Command. Packaging data retrieval is available from the managing Military Department's or Defense Agency's automated packaging files, CD-ROM products, or by contacting the responsible packaging activity.

6. NOTES

(This section contains information of a general or explanatory nature that may be helpful, but is not mandatory.)

6.1 Intended use. The wire rope covered by this specification is intended for use in aircraft flight control systems applications where high resistance is needed against corrosion, abrasion, and fatigue wear.

* 6.2 Acquisition requirements. Acquisition documents should specify the following:

- a. Title, number, and date of the specification.
- b. Selection of type and composition of wire rope (see 1.2).
- c. Size and construction of wire rope (see specification sheet).
- d. Issue of DoDISS to be cited in the solicitation, and if required, the specific issue of the individual documents referenced (see 2.2.1 and 2.3).

MIL-DTL-83420J

- e. For type II, also specify jacket outside diameter.
- f. For composition A, specify type of protective coating.
- g. Length of wire rope per reel to be furnished.
- h. Selection of applicable levels of packaging and packing required (see 5.1).

6.3 Qualification. With respect to products requiring qualification, awards will be made only for products which are, at the time of award of contract, qualified for inclusion in Qualified Product List QPL-83420 whether or not such products have actually been so listed by that date. The attention of contractors is called to these requirements, and manufacturers are urged to arrange to contact the activity responsible for the Qualified Products List to determine the specific requirements that must be met for qualification. The activity responsible for the Qualified Products List is Defense Supply Center Richmond, ATTN: DSCR-VBD, Richmond, VA 23297-5610 and information pertaining to qualification of products may be obtained from that activity.

6.4 Definitions.

6.4.1 Center wire. The center of all strands is an individual wire and is designated as a center wire.

6.4.2 Jacketing. Jacketing is the sheet or shielding coating around the wire rope and is extruded over the wire rope to completely enclose the wire rope with a protective coating.

6.4.3 Lay (twist). The helical form taken by the wires in the strand and by the strand in the wire rope is characterized as the lay (twist) of the strands or wire rope, respectively. In a right-hand lay, the wires of strands are the same direction as the thread on a right-hand screw, and for a left-hand lay, the strands or wires lay in an opposite direction.

6.4.4 Length of lay (pitch). The distance parallel to the axis of the strand or cable, in which a wire or strand makes one complete turn about the axis, is designated as the length of lay (pitch) of the strand or wire rope.

6.4.5 Lubricant leak-out. Lubricant leak-out (see 3.3.4) and evaporation of the lubricant applied to the wire rope during fabrication and preparation of shipment can be expected. In order to ensure optimum performance with wire rope manufactured to this specification, the user should relubricate the wire rope upon installation and periodically throughout its service life. The method of lubrication, frequency, and identity of the approved military standard lubricant should be included in the appropriate aircraft maintenance manuals.

6.4.6 Master reel. The master reel is the large manufacturing reel that is used to hold the wire rope as it is continuously manufactured. The shipping reels are cut from the master reel as needed.

MIL-DTL-83420J

6.4.7 Ping. Ping is an audible sound given off as a result of an individual wire breaking in the wire rope. The sound is amplified and fed into a speaker system to a level distinctly detectable by the human ear.

6.4.8 Preforming. Wire and strand shaped, during fabrication of the wire rope, to conform to the form or curvature which they take in the finished wire rope.

6.4.9 Regular lay. Wire rope in which the direction of the lay of the wires in the strand is in an opposite direction to the lay of the strand in the wire rope.

* 6.4.10 Shipping reel. The shipping reels are cut from the master reel (see 6.4.6) as needed.

6.4.11 Strand. Each group of wires helically twisted is designated as a strand.

6.4.12 Strand core. A strand core consists of a single straight strand made of wires similar to the other strands comprising the cable in arrangement and number of wires.

6.4.13 Twist-off. Twist-off is a twisting severance of the strand or wire due to a malfunctioning of the stranding equipment.

6.4.14 Wire. Each individual cylindrical element is designated as a wire.

6.4.15 Wire rope. A group of 3 or more strands helically twisted is designated as a wire rope.

6.4.16 Wire rope diameter. The diameter of wire rope is the diameter of the circumscribing circle, or the distance across opposite strands.

6.5 Subject term (key word) listing.

Airplane
Coated
Guide
Plated
Pliable
Steel cable
Uncoated

6.6 Changes from previous issue. The margins of this specification are marked with asterisks to indicate where changes from the previous issue were made. This was done as a convenience only and the Government assumes no liability whatsoever for any inaccuracies in these notations. Bidders and contractors are cautioned to evaluate the requirements of this document based on the entire content irrespective of the marginal notations and relationship to the previous issue.

MIL-DTL-83420J

TABLE I. Construction, physical properties of type I, carbon steel and corrosion resistant steel wire.

Nominal rope diameter of wire (ref.)	Minimum rope diameter of wire	Tolerance on diameter (plus only)	Allowable increase of diameter at cut end	Construction	Minimum breaking strength composition A	Minimum breaking strength composition B	Approximate weight per 100 ft.
in.	in.	in.	in.		lbs.	lbs.	lbs.
1/32	.031	.006	.006	3 x 7	110	110	0.16
3/64	.046	.008	.008	7 x 7	270	270	0.42
1/16	.062	.010	.009	7 x 7	480	480	0.75
1/16	.062	.010	.009	7 x 19	480	480	0.75
3/32	.093	.012	.010	7 x 7	920	920	1.60
3/32	.093	.012	.010	7 x 19	1,000	920	1.74
1/8	.125	.014	.011	7 x 19	2,000	1,760	2.90
5/32	.156	.016	.017	7 x 19	2,800	2,400	4.50
3/16	.187	.018	.019	7 x 19	4,200	3,700	6.50
7/32	.218	.018	.020	7 x 19	5,600	5,000	8.60
1/4	.250	.018	.021	7 x 19	7,000	6,400	11.00
9/32	.281	.020	.023	7 x 19	8,000	7,800	13.90
5/16	.312	.022	.024	7 x 19	9,800	9,000	17.30
3/8	.375	.026	.027	7 x 19	14,400	12,000	24.30

TABLE II. Construction and dimensional properties of type II wire rope jacket tolerance.

Nominal diameter of wire rope	Construction	Outside diameter (O.D.) of jacket	Tolerance on jacket O.D. (plus only)	Jacket wall thickness (references)	Approximate weight per 100 ft.
in.		in.	in.	in.	lbs.
1/32	3 x 7	.046 (3/64)	.008	.008	0.22
3/64	7 x 7	.062 (1/16)	.010	.008	0.49
3/64	7 x 7	.078 (5/64)	.012	.016	0.76
1/16	7 x 7	.093 (3/32)	.012	.016	0.93
1/16	7 x 7	.125 (1/8)	.014	.031	1.18
1/16	7 x 19	.093 (3/32)	.012	.016	.093
1/16	7 x 19	.125 (1/8)	.014	.031	1.18
3/32	7 x 7	.125 (1/8)	.014	.016	1.85
3/32	7 x 7	.156 (5/32)	.016	.031	2.18
3/32	7 x 19	.125 (1/8)	.014	.016	1.99
3/32	7 x 19	.156 (5/32)	.016	.031	2.32
1/8	7 x 19	.187 (3/16)	.018	.031	3.62
5/32	7 x 19	.218 (7/32)	.018	.031	6.10
5/32	7 x 19	.281 (9/32)	.022	.063	7.51
3/16	7 x 19	.250 (1/4)	.018	.031	7.75
3/16	7 x 19	.312 (5/16)	.022	.063	9.20
7/32	7 x 19	.281 (9/32)	.020	.031	9.76
7/32	7 x 19	.343 (11/32)	.024	.063	11.55
1/4	7 x 19	.312 (5/16)	.020	.031	12.30
1/4	7 x 19	.375 (3/8)	.024	.063	14.42
9/32	7 x 19	.406 (13/32)	.024	.063	16.18
5/16	7 x 19	.437 (7/16)	.024	.063	19.80
3/8	7 x 19	.500 (1/2)	.027	.063	27.20

MIL-DTL-83420J

* TABLE III. Breaking strength of type I after endurance testing.

COMPOSITION		A			B		
Nominal diameter of bare wire rope	Construction	Tension load (-0,+10%) <u>1/ 4/</u>	Number of reversals	Minimum breaking strength <u>2/</u>	Tension load (minimum) <u>1/ 4/</u>	Number of reversals	Minimum breaking strength <u>3/</u>
in.		lbs.		lbs.	lbs.		lbs.
1/32	3 x 7	1.0	70,000	55	1.0	70,000	66
3/64	7 x 7	3.0	70,000	135	3.0	70,000	162
1/16	7 x 7	5.0	70,000	240	5.0	70,000	288
1/16	7 x 19	5.0	70,000	240	5.0	70,000	288
3/32	7 x 7	9.0	70,000	460	9.0	70,000	552
3/32	7 x 19	9.0	70,000	500	9.0	70,000	552
1/8	7 x 19	18.0	70,000	1,000	18.0	70,000	1,056
5/32	7 x 19	24.0	130,000	1,400	24.0	130,000	1,440
3/16	7 x 19	37.0	130,000	2,100	37.0	130,000	2,220
7/32	7 x 19	50.0	130,000	2,800	50.0	130,000	3,000
1/4	7 x 19	64.0	130,000	3,500	64.0	130,000	3,840
9/32	7 x 19	78.0	130,000	4,000	78.0	130,000	4,680
5/16	7 x 19	90.0	130,000	4,900	90.0	130,000	5,400
3/8	7 x 19	120.0	130,000	7,200	120.0	130,000	7,200

** 1 cycle = 2 reversals

1/ Tension is equal to one half the weight (w) which includes idler sheave and hanger.2/ Equal to 50 percent of the original minimum breaking strength.3/ Equal to 60 percent of the original minimum breaking strength.4/ The magnitude of the tension loads are test parameters only and are by no means intended as design criteria.* TABLE IV. Breaking strength of type II after endurance testing.

COMPOSITION		A			B		
Nominal diameter of bare wire rope	Construction	Tension load (-0,+10%) <u>1/ 3/</u>	Number of reversals	Minimum breaking strength <u>2/</u>	Tension load (minimum) <u>1/ 3/</u>	Number of reversals	Minimum breaking strength <u>2/</u>
in.		lbs.		lbs.	lbs.		lbs.
1/32	3 x 7	1.0	200,000	66	1.0	200,000	66
3/64	7 x 7	3.0	200,000	162	3.0	200,000	162
1/16	7 x 7	5.0	200,000	288	5.0	200,000	288
1/16	7 x 19	5.0	200,000	288	5.0	200,000	288
3/32	7 x 7	9.0	200,000	552	9.0	200,000	552
3/32	7 x 19	9.0	200,000	600	9.0	200,000	552
1/8	7 x 19	18.0	200,000	1,200	18.0	200,000	1,056
5/32	7 x 19	24.0	500,000	1,680	24.0	500,000	1,440
3/16	7 x 19	37.0	500,000	2,520	37.0	500,000	2,220
7/32	7 x 19	50.0	500,000	3,360	50.0	500,000	3,000
1/4	7 x 19	64.0	500,000	4,200	64.0	500,000	3,840
9/32	7 x 19	78.0	500,000	4,800	78.0	500,000	4,680
5/16	7 x 19	90.0	500,000	5,880	90.0	500,000	5,400
3/8	7 x 19	120.0	500,000	8,640	120.0	500,000	7,200

** 1 cycle = 2 reversals

1/ Tension is equal to one half the weight (w) which includes idler sheave and hanger.2/ Equal to 60 percent of the original minimum breaking strength.3/ The magnitude of the tension loads are test parameters only and are by no means intended as design criteria.

MIL-DTL-83420J

* TABLE V. Qualification and quality conformance tests and inspections.

Tests	Requirement paragraph	Qualification paragraph	Quality conformance paragraph
Ductility of steel	3.5.2.1	4.4.1.1	4.4.1.1
Adherence of coating	3.5.2.2	4.4.1.2	4.4.1.2
Identification of product	3.6-3.6.3	4.4.11	4.4.11
Examination of product	3.7 - 3.7.1.1	4.4.2 - 4.4.2.2	4.4.2 - 4.4.2.2
Breaking strength	3.5.3	4.4.3	4.4.3
Endurance for type I	3.5.4	4.4.4 - 4.4.4.2	4.4.4, 4.4.4.2
Endurance for type II	3.5.5	4.4.5 - 4.4.5.2	4.4.5, 4.4.5.2
Stretch limits	3.5.6	4.4.6	4.4.6
Test load	3.5.7	4.4.7 - 4.4.7.1	4.4.7 - 4.4.7.1
Tin and zinc coating	3.3.3.1 - 3.3.3.2	4.4.8.1 - 4.4.8.1.3	-
Low temp. flexibility	3.5.9	4.4.9	-
Resistance to fluids	3.5.10	4.4.10	-

* TABLE VI. Dimension of test sheave** used in type I endurance test.

Nominal diameter of wire rope (d)	Construction	Sheave		Ratio to 1	C 1/ 2/	G 1/	D	Er
		Composition A & B rm temp test	Composition A -65 °F (-54 °C) test	+1/64 -1/64	+1/64 -1/64	+0.005 -0.000	+0.002 -0.000	
in.				in.	in.	in.	in.	
1/32	3 x 7	18.0		0.703	3/8	0.562	.025	
1/32	3 x 7		23.0	0.814	3/8	0.750	.025	
3/64	7 x 7	12.0		0.703	3/8	0.562	.025	
3/64	7 x 7		16.0	0.891	3/8	0.750	.025	
1/16	7 x 7	12.0		0.938	3/8	0.750	.036	
1/16	7 x 7		16.0	1.188	3/8	1.000	.036	
1/16	7 x 19	7.0		0.625	3/8	0.438	.036	
1/16	7 x 19		9.5	0.782	3/8	0.594	.036	
3/32	7 x 7	13.0		1.406	3/8	1.220	.052	
3/32	7 x 7		14.0	1.594	3/8	1.313	.052	
3/32	7 x 19	7.0		0.938	3/8	0.656	.052	
3/32	7 x 19		9.5	1.172	3/8	0.891	.052	
1/8	7 x 19	7.0		1.250	3/8	0.875	.069	
1/8	7 x 19		9.5	1.562	3/8	1.188	.069	
5/32	7 x 19	9.5		1.953	3/8	1.484	.086	
3/16	7 x 19	9.5		2.343	1/2	1.781	.102	
7/32	7 x 19	9.5		2.734	1/2	2.078	.118	
1/4	7 x 19	9.5		3.125	1/2	2.375	.134	
9/32	7 x 19	9.5		3.515	1/2	2.671	.150	
5/16	7 x 19	9.5		3.907	9/16	2.969	.167	
3/8	7 x 19	9.5		4.687	9/16	3.562	.200	

1/ Reference numbers, not a mandatory dimension. Left to manufacturer's discretion.

2/ $C=D+3d$

** The dimensions of the test sheaves are test parameters only and are by no means intended as design criteria.

MIL-DTL-83420J

*

TABLE VII. Dimensions of test sheaves ** used in type II endurance test.

Nominal Diameter of wire rope (d)	Construction	Sheave	Outside	C <u>1/</u> <u>2/</u>	G <u>1/</u>	D	Er
		Ratio to 1 (O.D.)	Diameter jacket (O.D.)	+1/64 -1/64	+1/64 -1/64	+0.005 -0.000	+0.002 -0.000
in.				in.	in.	in.	in.
1/32	3 x 7	16.0	3/64	0.938	3/8	0.750	.036
3/64	7 x 7	12.0	1/16	0.938	3/8	0.750	.036
3/64	7 x 7	12.0	5/64	1.172	3/8	0.938	.044
1/16	7 x 7	12.0	3/32	1.405	3/8	1.125	.052
1/16	7 x 7	12.0	1/8	1.875	3/8	1.500	.069
1/16	7 x 19	7.0	3/32	0.938	3/8	0.656	.052
1/16	7 x 19	7.0	1/8	1.250	3/8	0.875	.069
3/32	7 x 7	12.0	1/8	1.875	3/8	1.500	.069
3/32	7 x 7	12.0	5/32	2.344	3/8	1.875	.086
3/32	7 x 19	7.0	1/8	1.250	3/8	0.875	.069
3/32	7 x 19	7.0	5/32	1.563	3/8	1.094	.086
1/8	7 x 19	7.0	3/16	1.875	3/8	1.313	.102
5/32	7 x 19	9.5	7/32	2.734	3/8	2.078	.118
5/32	7 x 19	9.5	9/32	3.515	3/8	2.671	.150
3/16	7 x 19	9.5	1/4	3.125	1/2	2.375	.134
3/16	7 x 19	9.5	5/16	3.907	1/2	2.969	.167
7/32	7 x 19	9.5	9/32	3.515	1/2	2.671	.150
7/32	7 x 19	9.5	11/32	4.296	1/2	3.265	.184
1/4	7 x 19	9.5	5/16	3.907	1/2	2.969	.167
1/4	7 x 19	9.5	3/8	4.687	1/2	3.562	.200
9/32	7 x 19	9.5	13/32	5.078	1/2	3.859	.215
5/16	7 x 19	9.5	7/16	5.469	9/16	4.156	.231
3/8	7 x 19	9.5	1/2	6.250	9/16	4.750	.263

1/ Reference numbers, not a mandatory dimension. Left to manufacturer's discretion.

2/ C=D+3d

** The dimensions of the test sheaves are test parameters only and are by no means intended as design criteria.

MIL-DTL-83420J

TABLE VIII. Dimensions of reels per wire rope size.

Overall $\frac{1}{2}$ diameter of wire rope in.	1,000 ft.		3,000 ft.	
	Minimum diameter of drum	Diameter of arbor hole	Minimum diameter of drum	Diameter of arbor hole
	in.	in.	in.	in.
1/32	4	1-1/8	6	1-1/8
3/64	4	1-1/8	6	1-1/8
1/16	6	1-1/8	8	1-1/8
3/32	6	1-1/8	10	1-1/8
1/8	8	1-1/8	10	2-1/8
5/32	8	1-1/8	10	2-1/8
3/16	8	2-1/8	10	2-1/8
7/32	8	2-1/8	10	2-1/8
1/4	10	2-1/8	12	2-1/8
9/32	10	2-1/8	12	2-1/8
5/16	12	2-1/8	12	2-1/8
3/8	12	2-1/8	12	2-1/8
	5,000 ft.		10,000 ft.	
1/32	8	1-1/8	10	1-1/8
3/64	8	1-1/8	10	1-1/8
1/16	10	1-1/8	12	2-1/8
3/32	10	1-1/8	12	2-1/8
1/8	10	1-1/8	12	2-1/8
5/32	12	2-1/8	12	2-1/8
3/16	12	2-1/8	12	2-1/8
7/32	12	2-1/8	12	3-1/8
1/4	12	2-1/8	18	3-1/8
9/32	12	2-1/8	18	3-1/8
5/16	12	2-1/8	18	3-1/8
3/8	16	2-1/8	18	3-1/8

$\frac{1}{2}$ For type II, the wire rope size is the diameter of the wire rope with the nylon jacket.

MIL-DTL-83420J

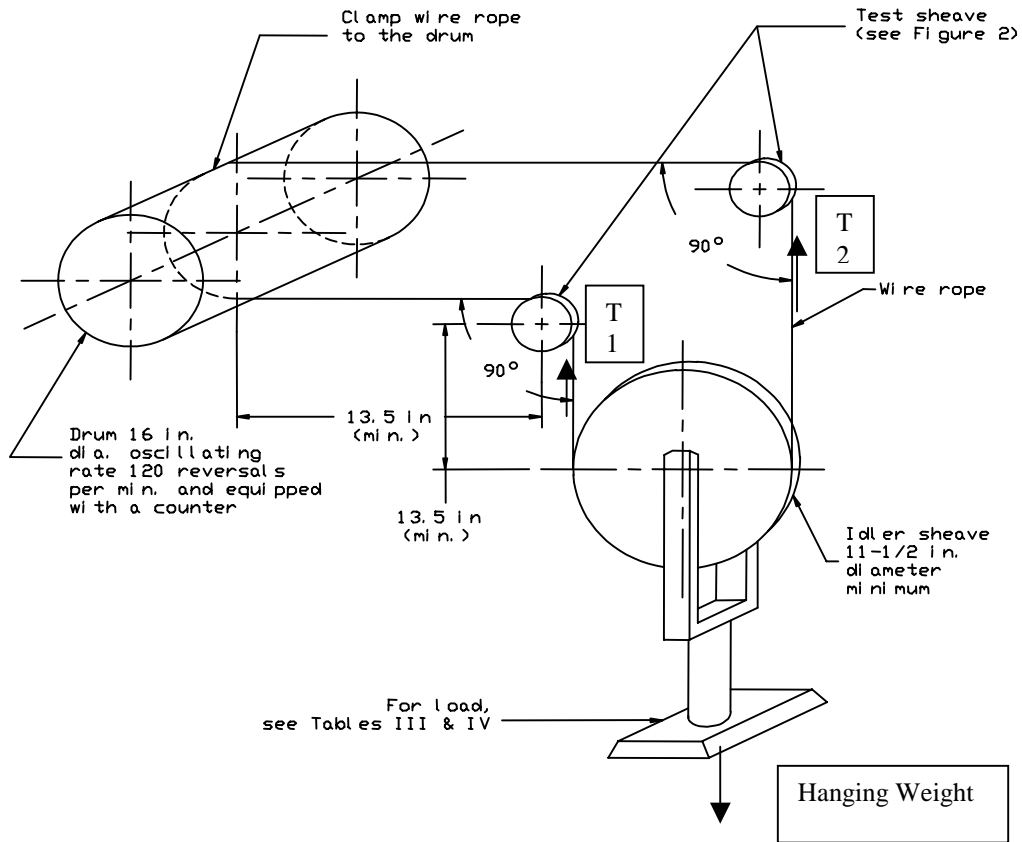

NOTE: The dimensions of the test sheaves are test parameters only and are by no means intended as design criteria. For test loads, see tables III and IV.

FIGURE 1. Diagram of endurance testing machine and conditions of the test.

MIL-DTL-83420J

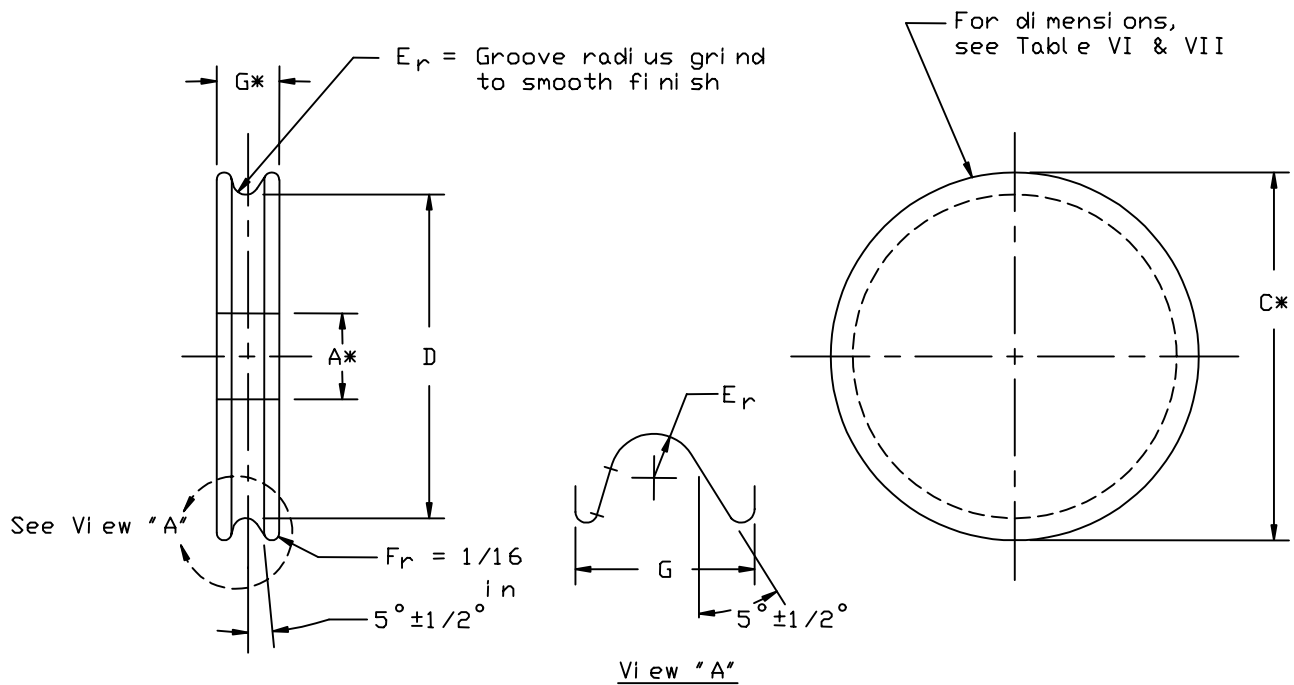

NOTE: These dimensions are only reference numbers; these may be varied by the manufacturer.

Material: Tool Steel

Heat Treat: Harden to Rockwell C60 minimum.

NOTE: "A" support sheaves on suitable ball or roller bearing or shaft extensions supported on suitable ball or roller bearings.

The dimensions of the test sheaves are test parameters only and are by no means intended as design criteria.

FIGURE 2. Test sheaves used in standard endurance test.

MIL-DTL-83420J

Custodians:

Army - AV
Navy - AS
Air Force - 99

Preparing activity:

DLA - GS5

(Project 4010-0109)

Reviewer:

Air Force - 82

STANDARDIZATION DOCUMENT IMPROVEMENT PROPOSAL

INSTRUCTIONS

1. The preparing activity must complete blocks 1, 2, 3, and 8. In block 1, both the document number and revision letter should be given.
2. The submitter of this form must complete blocks 4, 5, 6, and 7.
3. The preparing activity must provide a reply within 30 days from receipt of the form.

NOTE: This form may not be used to request copies of documents, nor to request waivers, or clarification of requirements on current contracts. Comments submitted on this form do not constitute or imply authorization to waive any portion of the referenced document(s) or to amend contractual requirements.

I RECOMMEND A CHANGE:		1. DOCUMENT NUMBER MIL-DTL-83420J	2. DOCUMENT DATE (YYYYMMDD) 20001221
DOCUMENT TITLE WIRE ROPE, FLEXIBLE, FOR AIRCRAFT CONTROL			
4. NATURE OF CHANGE (<i>Identify paragraph number and include proposed rewrite, if possible. Attach extra sheets as needed.</i>)			
5. REASON FOR RECOMMENDATION			
6. SUBMITTER			
a. NAME (<i>Last, First, Middle Initial</i>)		b. ORGANIZATION	
c. ADDRESS (<i>Include Zip Code</i>)		d. TELEPHONE (<i>Include Area Code</i>) (1) Commercial (2) DSN (<i>if applicable</i>)	7. DATE SUBMITTED (YYYYMMDD)
8. PREPARING ACTIVITY			
a. NAME Defense Supply Center Richmond		b. TELEPHONE (<i>Include Area Code</i>) (1) Commercial (804) 279-5019 (2) DSN 695-5019	
c. ADDRESS (<i>Include Zip Code</i>) ATTN: DSCR-VBD (C. Hammond) 8000 Jefferson Davis Highway Richmond, VA 23297-5610		IF YOU DO NOT RECEIVE A REPLY WITHIN 45 DAYS, CONTACT: DEFENSE STANDARDIZATION PROGRAM OFFICE (DLSC-LM) 8725 John J. Kingman Road, Suite 2533 Fort Belvoir, Virginia 22060-6221 Telephone (703) 767-6888 DSN 427-6888	