

INCH-POUND

MIL-DTL-82156D(MC)

21 October 1997

SUPERSEDING

MIL-C-82156C(MC)

13 June 1995

DETAIL SPECIFICATION

COAT, MAN'S - SCARLET, DRUM AND BUGLE CORPS, MUSICIANS

This specification is approved for use by U.S. Marine Corps, Department of the Navy, and is available for use by all Departments and Agencies of the Department of Defense.

1. SCOPE

1.1. Scope. This specification covers requirements for musician's scarlet wool drum and bugle corps coats.

1.2. Classification. The coats will be one type in the following sizes as specified (see 6.2):

Beneficial comments (recommendations, additions, deletions) and any pertinent data which may be of use in improving this document should be addressed to the Commander (PSE-D), Marine Corps Systems Command, Quantico, VA 22134-5010 by using the Standardization Document Improvement Proposal (DD Form 1426) appearing at the end of this document or by letter.

AMSC N/A

FSC 8405

DISTRIBUTION STATEMENT A. Approved for public release; distribution is unlimited.

MIL-DTL-82156D(MC)

Schedule of sizes(Short, Regular, Long, Extra Long)

34 35 36 37 38 39 40 41 42 44 46

1.3. Individual orders. When the coat is custom tailored to an individual order, this specification will govern except that the detail requirements of Section 3, Table I, may be modified to the extent necessary for good custom tailoring practices.

2. APPLICABLE DOCUMENTS

2.1. General. The documents listed in this section are specified in sections 3 and 4 of this specification. This section does not include documents cited in other sections of this specification or recommended for additional information or as examples. While every effort has been made to ensure the completeness of this list, document users are cautioned that they must meet all specified requirements documents cited in sections 3 and 4 of this specification, whether or not they are listed.

2.2. Government documents.

2.2.1 Specifications, standards, and handbooks. The following specifications, standards, and handbooks form a part of this document to the extent specified herein. Unless otherwise specified, the issues of these documents are those listed in the issue of the Department of Defense Index of Specifications and Standards (DoDISS) and supplement thereto, cited in the solicitation (see 6.2).

SPECIFICATIONS

FEDERAL

A-A-50196	- Thread, Silk
A-A-50198	- Thread, Gimp, Cotton, Buttonhole
A-A-50199	- Thread, Polyester Core, Cotton or Polyester Covered
A-A-52071	- Tape, Textile, Cotton, General Purpose (Unbleached, Bleached, or Dyed)
A-A-52094	- Thread, Cotton
A-A-52097	- Cloth, Wigan, Cotton
A-A-52106	- Cloth, Twill or Plain Weave, Polyester and Polyester Blend

MIL-DTL-82156D(MC)

DDD-L-20 - Label: For Clothing, Equipage, and Tentage
(General Use)

DEPARTMENT OF DEFENSE

MIL-C-368 - Cloth, Satin, Rayon and Cloth, Twill, Rayon
MIL-DTL-3461 - Button, Insignia, Metal, Uniform and Cap
MIL-P-15064 - Pads, Shoulder and Sleeve-Head
MIL-E-20652 - Eyelets, Metallic, Eyelet Washers (General
Specification For)
MIL-C-21115 - Cloth, Tropical: Wool, Polyester/Wool
MIL-DTL-82114 - Coat Front - For Coats, Musicians

STANDARDS

FEDERAL

FED-STD-191 - Textile Test Methods
FED-STD-751 - Stitches, Seams, and Stitchings

(Unless otherwise indicated, copies of the above specifications, standards, handbooks are available from the Standardization Document Order Desk, 700 Robbins Avenue, Building 4D, Philadelphia, PA 19111-5094.)

2.3. Non-Government publications. The following document(s) form a part of this document to the extent specified herein. Unless otherwise specified, the issues of the documents which are DoD adopted are those listed in the issue of the DoDISS cited in the solicitation. Unless otherwise specified, the issues of documents not listed in the DoDISS are the issues of the documents cited in the solicitation (see 6.2).

ASTM E1282 - Standard Guide for Specifying the Chemical Compositions and Selecting Sampling Practices and Quantitative Analysis Methods for Metals and Alloys

(Application for copies should be addressed to American Society for Testing and Materials, 1916 Race Street, Philadelphia, PA 19103.)

ANSI/ASQC 21.4 - Sampling Procedures and Tables for Inspection by Attributes

MIL-DTL-82156D(MC)

(Application for copies should be addressed to The American National Standards Institute, 11 West 42nd Street, New York, NY 10036.)

Department of Defense (DoD) Standard Color Card of
Official Standardized Shades for Sewing Threads 1968

(Application for copies should be addressed to the Color Association of the United States, Inc., 409 W. 44th Street, New York, NY 10016-0927.)

2.4. Order of precedence. In the event of a conflict between the text of this document and the references cited herein, the text of this document takes precedence. Nothing in this document, however, supersedes applicable laws and regulations unless a specific exemption has been obtained.

3. REQUIREMENTS

3.1. Standard sample. Standard samples are furnished solely for guidance and information to the contractor (see 6.3). Variation from this specification may appear in the sample, in which case the specification shall govern.

3.2. First article. When specified (see 6.2), a sample shall be subjected to first article inspection in accordance with 4.3.

3.3. Materials.

3.3.1 Basic material. The basic material shall be cloth, wool, tropical, scarlet, shade 2502 (see 6.3), 10.5 ounces, conforming to type I, class 1 of MIL-C-21115.

3.3.2 Lining. The material for lining the coat and collar and for making the underarm shields, collar eyelet covers, coat hanger, straps to secure the lining to the bottom edge of the coat, and the front eyelet cover shall be cloth, satin rayon twill, scarlet, shade 2506 (see 6.3), conforming to class 1 of MIL-C-368.

3.3.3 Cloth, twill or plain weave. The stays for the armhole and shoulder seams; the reinforcement pieces for the collar eyelets; and the binding for the neck edge of the coat front interlining and the lower edge of the collar interlining shall be cut from cloth, twill or plain weave, polyester or polyester

MIL-DTL-82156D(MC)

blend conforming to A-A-52106, except the requirement for non-fibrous material and seam efficiency shall not apply. The color of the cloth shall be natural, for the armhole and shoulder seam stays, the collar eyelet reinforcement pieces, and the binding for the neck edge of the coat front interlining; and black for the binding for the lower edge of the collar interlining.

3.3.4 Collar interlining. The material for interlining the collar shall be cloth, cotton buckram, double texture, laminated starch finish, natural color, conforming to type IV of A-A-50186. The weight of the laminated cloth shall be 21 to 23 ounces per square yard.

3.3.5 Reinforcement discs. The reinforcement discs for the buttons secured to the back side seam, with ring toggles, shall be punched from cloth, cotton, buckram specified in 3.3.4. The reinforcement discs shall be 7/8 inch in diameter with a 1/8 inch diameter hole at the center.

3.3.6 Padding for collar. The material for padding the collar shall be suitable cotton felt, white, weight 4.25 to 4.75 ounces per square yard.

3.3.7 Coat fronts. The coat fronts shall conform to class 1 of MIL-DTL-82114.

3.3.8 Shoulder pads. The shoulder pad shall conform to the requirements of type I, class 2 of MIL-P-15064.

3.3.9 Sleeve-head pads. The sleeve-head pads shall conform to type IV of MIL-P-15064.

3.3.10 Stay tape. The stay tape for armholes shall be cotton, unbleached 1/4 inch wide, conforming to type II, class 1 of A-A-52071, except the requirements for non-fibrous material shall not apply.

3.3.11 Piping. The material for piping shall be cloth, polyester/wool blend, black, shade 2607 (see 6.3), conforming to type III of MIL-C-21115, cut 5/8 to 3/4 inch wide for the piping for shoulder straps, lower edge of collar, and ornamental sleeve patches; and 1 inch wide for piping the front and bottom edges of the coat.

MIL-DTL-82156D(MC)

3.3.11.1. Vinyl piping. The white vinyl piping for the upper edge of the collar shall be tubular, with 7/16 inch wide welt and serrated edges.

3.3.12 Bias binding. The binding for the underarm shields shall be bias cut out of the material specified in 3.3.2. The binding shall be 5/8 to 7/8 inch wide and have sized edges.

3.3.13 Wigan. The material for reinforcing the bottom edge of the sleeves shall be cloth, cotton wigan, 2.5 ounces, conforming to type I of A-A-52097.

3.3.14 Thread.

3.3.14.1. Silk thread. The silk thread shall conform to A-A-50196 as follows, except the requirements for extractable matter shall not apply.

Use	Type	Class	Ticket No.	Ply
Bartacks and all outside seaming and stitching.	I	-	A	-
Machine felling.	-	-	O	-
Making buttonholes in coat.	I	-	B and F	3
Hand felling and hand selling.	III	3	C	2

3.3.14.2. Cotton thread. The cotton thread shall conform to A-A-52094 as follows:

Use	Type	Ticket No.	Ply
All inside seaming and stitching.	III	A	3
Serging and overedge stitching.	I	70	2
Machine tacking armholes.	I	40	3

The thread for basting shall be good commercial grade cotton. As an alternate to the cotton thread, a polyester core, cotton or polyester covered thread conforming to A-A-50199, ticket No. 70, 2-ply or ticket No. 50, 2-ply may be used.

3.3.14.3. Color and colorfastness. All thread shall be dyed scarlet, shade W, cable No. 66040, except the cotton thread for basting and machine tacking armholes may be white, and the cotton thread for overedge stitch the piping at the bottom edge of the

MIL-DTL-82156D(MC)

coats shall be black. The colored threads shall show the following colorfastness when tested as specified in the applicable thread specification:

<u>Thread</u>	<u>Color</u>	<u>Wet (dry) Cleaning</u>	<u>Light</u>
Cotton	Scarlet	Good	--
Silk	Scarlet	Fair	Fair
Silk	Black	Good	Good

NOTE: See DoD Standard Color Card of Standardized Shades for Sewing Threads 1968.

3.3.15 Gimp. The buttonhole gimp shall be cotton, ticket No. 8, soft or glazed finish, conforming to type I or II of A-A-50198. The color of the gimp shall be scarlet, shade W, cable No. 66040, and shall show good fastness to wet (dry) cleaning.

3.3.16 Buttons.

3.3.16.1. Insignia buttons. The insignia buttons shall be metal, gold plated, 27-line for shoulders, belt loops and ornamental sleeve patches and 40-line for fronts, conforming to type I, style 3, class A, subclass 1 of MIL-DTL-3461.

3.3.16.2. Ring toggles. Ring toggles for securing the 27-line insignia buttons to the belt loops, ornamental sleeve patches and shoulder straps shall conform to MIL-DTL-3461.

3.3.17 Collar closure hook and eye. The hook and eye for closing the collar shall be brass, black, japanned finish or black chemical finish, followed by a clear lacquer coating and conform to the requirements of Figure 6.

3.3.17.1. Eyelets. The eyelets for the collar shall be brass, rolled flange type, with the barrel scored with six to eight scores. The eyelets shall conform to MIL-E-20652, sheet 1A-BE108 and be enameled a black shade.

3.3.18 Labels. Each coat shall have a combination identification/instruction label and size label conforming to DDD-L-20. The coats are intended to be wet (dry) cleaned and the label shall show fastness to wet (dry) cleaning.

MIL-DTL-82156D(MC)

3.3.18.1. Combination identification/instruction label. The combination identification/instruction label shall conform to type VI, classes 1 and 3 (combined) of DDD-L-20, except all printing and the space between lines of printing shall be minimum 10 point (approximately 1/8 inch). The content and format shall be as follows:

Nomenclature:

Contract number:

Name of contractor:

Wool Products Act information:

DRY CLEAN ONLY

3.3.18.2. Size label. The size label shall be type VI, class 2 of DDD-L-20. The label shall consist of the numerical size designation specified in 1.2 followed by the letter S (short), R (regular), L (long), or XL (extra long) as shown by the following example:

40R

3.4. Design. The coat shall be the U.S. Marine Corps design shown on Figures 1 through 4. The coat shall be seven button, single breasted, form-fitting, fully lined having a one-piece front; waist and chest darts; a four-piece back without a center vent; belt loops to button; ornamented at sleeve ends; shoulder straps to button; and a stand up collar with hook and eye for front closure and a metal eyelet at each end for removable branch of service insignia. The top and bottom edges of the collar; the front and bottom edges of the coat; the top, bottom, and scalloped back edges of the ornamental sleeve patches; and the edges of the shoulder straps shall be piped with the material specified in 3.3.11.

3.5. Patterns. Standard patterns will be furnished to the contractor by the Government. The standard patterns shall not be altered in any way and shall be used only as a guide for cutting the contractor's working patterns. The contractor's working patterns shall be identical to the standard pattern. The standard patterns shall provide 5/8 inch allowance for center back, 3/4 inch allowance for side seams, and 3/8 inch allowance for all other seams except as otherwise specified in Table I. Standard patterns show size and are marked and notched for proper cutting, placement and assembly of component parts.

MIL-DTL-82156D(MC)

3.5.1 List of pattern parts. Coats shall be cut from the materials specified herein in accordance with the pattern parts indicated below:

ITEM	PATTERN NOMENCLATURE	NO. OF CUT PARTS
Material basic: Cloth, wool, tropical		
1	Front	2
2	Front facing, right	1
3	Front facing, left	1
4	Side back	2
5	Center back	2
6	Top sleeve	2
7	Under sleeve	2
8	Collar, outer ply	2
9	Shoulder straps, top ply	2
10	Shoulder straps, under ply	2
11	Ornamental sleeve patch, top ply	2
12	Ornamental sleeve patch, under ply	2
13	Belt loops	2
14	Underarm shields	2
Material: Cloth, rayon lining		
15	Front	2
16	Side back	2
17	Center back	2
18	Top sleeve	2
19	Under sleeve	2
20	Collar lining	1
21	Collar eyelet cover	2
22	Underarm shield	4
23	Front eyelet cover	1
Material: Cloth, cotton buckram		
24	Collar interlining	1
Marker		
25	Sleeve turnup and sleeve ornamentation marker	-

MIL-DTL-82156D(MC)

3.6. Construction.

3.6.1 Manufacturing requirements. The coat shall be manufactured in accordance with the operations and the stitch, seam, and stitching types specified in Table I.

3.6.1.1. Operations. The contractor is not required to follow the exact sequence of the operations as listed in Table I, but all operations specified shall be used to manufacture the coats.

3.6.1.2. Stitches, seams and stitching. The stitch, seam and stitching types specified in Table I shall conform to FED-STD-751. The number of stitches per inch as specified in Table I indicates the minimum and maximum number permitted. All overedge stitching shall be done on serging machine with a knife attachment properly set to trim the raveled edge without cutting the material.

3.6.1.2.1 Tacking and backstitching. Ends all seams and stitching (stitch type 301), except ends of a continuous line of stitching, when not caught in other seams or stitches, shall be backstitched not less than 1/4 inch. The ends of a continuous line of stitching shall be overlapped not less than 1/2 inch. Thread breaks shall be secured back of the break not less than 1/2 inch.

3.6.1.3. Shade markings. The component parts of the coat cut from one piece of wool and lining materials, including pairs of sleeve linings and underarm shields when cut from ends, shall be shade marked to ensure a uniform shade and size throughout the garment. Any method of shade marking may be used except:

- a. Corrosive metal fastening devices.
- b. Sew-on shade tickets.
- c. Adhesive type tickets where adhesive causes discoloration or whose adhesive mass adheres to the material upon removal of the tickets.

MIL-DTL-82156D(MC)

TABLE I. Manufacturing requirements.

NO	OPERATION	STCH TYPE	SEAM/ STCH TYPE	STCH/IN	NDL	BOB/ LPR
1	<p><u>Cutting.</u></p> <p>a. Cut coats in strict accordance with the patterns furnished by the Government.</p> <p>b. Cut all materials in the direction of the warp as indicated by the directional lines on the patterns.</p> <p>c. Cut all scarlet wool parts of the coat from one piece of basic material, except the following parts may be cut from ends: under ply of shoulder straps and under ply of ornamental sleeve patch. Parts cut from ends shall harmonize with the shade of the coat.</p> <p>d. Cut the body and collar linings, the front eyelet covers, and the top ply of the underarm shields from one piece of rayon lining material. All other rayon lining parts may be cut from ends. When pairs of sleeve linings are cut from ends, the shade of the sleeve linings shall match. Cut the strips for coat hanger and lining securing straps 1-1/8 inches wide.</p> <p>e. Cut twill or plain weave stays for the armhole and shoulder seams on the bias 3/8 inch wide and $4 \pm 1/4$ inches long. Cut the twill or plain weave for binding the neck edge of the coat front interlining on the bias, 3/4 inch wide and approximately 5 inches long. Cut the twill or plain weave reinforcement pieces of collar eyelets not less than 2 inches long by 1-3/4 inches wide.</p> <p>f. Cut the cotton buckram for interlining the collar on the straight in accordance with the pattern furnished.</p> <p>g. Cut the cotton felt, for padding the collar, 1-1/4 inches wide and of sufficient length to fold over the ends of the interlining for each size collar.</p>					

MIL-DTL-82156D(MC)

TABLE I. Manufacturing requirements - Continued.

NO	OPERATION	STCH TYPE	SEAM/ STCH TYPE	STCH/IN	NDL	BOB/ LPR
1	<p><u>Cutting.</u> (cont'd)</p> <p>h. Cut the piping material (see 3.3.11) for piping the front and bottom edges of coats, the edges of the shoulder straps, lower edge of collar, and ornamental sleeve patch, on the straight. The piping shall but cut 5/8 to 3/4 inch wide for shoulder straps, and ornamental sleeve patches, and 1 inch wide for front and bottom edges of coat. Cut the binding material specified in 3.3.12 for the top and bottom edges of the collar interlining 1-1/8 inches wide on the straight.</p> <p>i. Cut the wigan for reinforcing the bottom of the sleeves on the bias in accordance with the pattern.</p> <p>j. Punch the reinforcement discs for buttons secured to the side seam from cloth, cotton buckram. The reinforcement discs shall be 7/8 inch in diameter with 1/8 inch diameter hole at the center.</p>					
2	<p><u>Replacement of damaged parts.</u></p> <p>a. At the time of cutting replace any part, of coat containing holes; seriously weakening defects, such as smashes, multiple floats, loose or weakening slubs, etc. expected to develop into holes; shade bars and dye streaks; or unsightly slubs etc., affecting appearance.</p> <p>b. Replace any part damaged during the manufacturing process by needle chews which may be expected to develop into holes, scissor or knife cuts, tears, mends or burns, in the material, affecting appearance.</p>					
3	<p><u>Shade marking.</u></p> <p>a. Mark or ticket (see 3.6.1.3) all component parts cut from one piece of basic and lining materials, and pairs of sleeve joinings when cut from ends, to ensure uniform shade and size through the coat.</p>					

MIL-DTL-82156D(MC)

TABLE I. Manufacturing requirements - Continued.

NO	OPERATION	STCH TYPE	SEAM/ STCH TYPE	STCH/IN	NDL	BOB/ LPR
3	<u>Shade marking.</u> (cont'd) b. The use of tickets with any metal fastening devices is prohibited on the rayon lining.					
4	<u>Make coat hanger and lining securing straps.</u> Finished appearance. The coat hanger and lining securing straps shall finish 1/4 to 3/8 inch wide. a. Fold the 1-1/8 inch wide strip of lining material in half lengthwise, turn the edges to the inside and seam 1/16 inch from the turned edges. b. Cut the coat hanger 3-3/4 ± 1/4 inches long. c. Cut the lining securing straps 4-1/2 ± 1/4 inches long.	301	EFp-1	12-16	A	A
5	<u>Make collar eyelet covers.</u> Finished appearance. The collar eyelet covers shall finish 1-3/4 ± 1/8 inches wide. a. Turn under the side edges of the collar eyelet cover and stitch 1/16 to 1/8 inch from folded edges, catching the turned under portions in the stitching. b. Fold each cover in half across the width and seam 1/16 to 1/8 inch from the folded side edges.	301	EFa-1 (each side edge)	12-16	A	A
		301	SSa-1	12-16	A	A
6	<u>Make underarm shields.</u> Finished appearance. The shields shall be made from one ply of basic material and shall finish smooth and flat without puckers, pleats, gathers, or other distortions. a. Bind the rounded edge of shield with bias binding, turning under the outside raw edge of the binding only, and catching the turned under portion in the stitching 1/16 inch from the folded edge.	301	SSa-1	12-16	A	A

MIL-DTL-82156D(MC)

TABLE I. Manufacturing requirements - Continued.

NO	OPERATION	STCH TYPE	SEAM/ STCH TYPE	STCH/IN	NDL	BOB/ LPR
7	<u>Make front eyelet cover.</u> a. Fold front eyelet cover in half lengthwise, turn in the raw top and bottom edges and seam 1/16 to 1/8 inch from the raw edge and folded top and bottom edges.	301	SSa-1 (raw edge) SSc-1 (top and bottom edges)	12-16	A	A
8	<u>Make belt loops.</u> Finished appearance. The belt loops shall be uniform in appearance and shall finish smooth and flat without puckers, pleats, gathers, or other distortions. The buttonholes shall be clean cut, well made and well worked over gimp to fit a 27-line insignia button. The gimp and thread shall be pulled through to the underside of the loops. The purling of the buttonholes shall be on the outside. a. Fold the belt loops in half lengthwise, face to face, forming two plies. b. Seam the two plies together along the side and pointed edges, 3/16 inch from the raw edges. c. Trim the corners and point for proper turning. Turn loops, working out completely the point and seamed edges. d. Edge stitch the loops uniformly 1/16 to 1/8 inch from folded and seamed edges. e. Make a horizontal, eyelet end, square-bar type buttonhole, cut 3/4 inch long, in each loop midway between the back and front edges, with the inside edge of the eyelet end of the buttonhole finishing 5/8 inch from pointed end of the loop.	301	SSe-2 (a)	12-16	A (silk)	A (silk)
		301	SSe-2 (b) (seamed edges) OSf-1 (folded edges)	12-16	A (silk)	A (silk)
		Button- holes		60 per button- hole (not incl. bartack)	B (silk)	F (silk)

MIL-DTL-82156D(MC)

TABLE I. Manufacturing requirements - Continued.

NO	OPERATION	STCH TYPE	SEAM/ STCH TYPE	STCH/IN	NDL	BOB/ LPR
8	<u>Make belt loops.</u> (cont'd) f. Securely bartack the end of the buttonholes, catching the ends of the gimp and thread in the bartack. Trim the ends of the gimp and thread.	Bartack		21 per bartack	A (silk)	A (silk)
9	<u>Make shoulder straps.</u> Finished appearance. The shoulder straps shall be uniform in appearance and shall finish smooth and flat, without twists, gathers, puckers, pleats, or other distortions. The piping shall be evenly worked out and shall extend uniformly 1/8 inch beyond the seamed edges of the shoulder straps. The buttonholes shall be clean cut, well made and well worked over the gimp to fit a 27-line insignia button. The gimp and thread shall be pulled through to the underside of the straps. The purling of the buttonholes shall be on the outside. a. The shoulder straps shall be made of two plies of basic material, piped with a 5/8 to 3/4 inch wide strip of piping material specified in 3.3.11. b. Turn under one edge of the piping 5/16 inch and seam the turned under portion to the body of the piping 1/8 inch from the turned raw edge. c. Position the right side of the top ply of the shoulder strap on the hemmed piping with the raw edges of shoulder strap in line with the piping stitching line. d. Join shoulder strap to piping along the back, front and collar end, 1/8 inch from the inner edge of piping. e. Trim and notch the piping in accordance with good manufacturing practices in order to prevent pulling and to eliminate gathers and bulges around the collar end.					
		301	EFa-1	10-14	A	A
		301	SSe-2 (a)	10-14	A (silk)	A (silk)

MIL-DTL-82156D(MC)

TABLE I. Manufacturing requirements - Continued.

NO	OPERATION	STCH TYPE	SEAM/ STCH TYPE	STCH/IN	NDL	BOB/ LPR
9	<u>Make shoulder straps.</u> (cont'd)					
	f. Position the top ply on the under ply face to face, with the outer edge of piping and raw edge of the under ply even and back notches matching.	301	SSk-1 (a) (without cord)	10-14	A (silk)	A (silk)
	g. Stitch along the back, front, and collar end through all plies 3/16 inch from the inner raw edge of the piping. Trim any excess material if necessary.	301	SSk-1 (a) (without cord)	10-14	A (silk)	A (silk)
	h. Turn the straps, completely working out the piped edges.					
	i. Topstitch the straps uniformly, 3/16 inch from the folded edge of the piping.	301	SSk-1 (b) (without cord and top-stitched)	10-14	A	A
	j. Press the shoulder straps smooth and flat with a heated pressing iron or pressing machine.					
	k. Make a horizontal, eyelet end, square-bar type buttonhole cut 3/4 inch long, in each strap, midway between the back and front edges, and with the inside edge of the eyelet end of the buttonhole finishing 5/8 inch from outer edge of piping at the collar end of strap.	Button-hole		60 per button-hole	B (silk)	F (silk)
	l. Securely bartack the end of the buttonhole, catching the ends of the gimp and thread in the bartack. Trim the ends of the gimp and thread.	Bartack		21 per bartack	A (silk)	A (silk)

MIL-DTL-82156D(MC)

TABLE I. Manufacturing requirements - Continued.

NO	OPERATION	STCH TYPE	SEAM/ STCH TYPE	STCH/IN	NDL	BOB/ LPR
10	<u>Make ornamental sleeve patches.</u> Finished appearance. The ornamental sleeve patch shall be uniform in appearance and shall finish smooth and flat, without twists, gathers, puckers, or other distortions. The piping shall be evenly worked out and shall extend uniformly 1/8 inch beyond the seamed edges of the sleeve patch. The eyelet shall be well worked with the purling on the outside of the sleeve patch and shall finish with a 1/8 to 3/16 inch diameter opening.					
10	<u>Make ornamental sleeve patches.</u> (cont'd) a. The ornamental sleeve patch shall be made of two plies of basic material, piped with a 5/8 to 3/4 inch wide strip of piping material specified in 3.3.11. b. Turn under one edge of the piping 5/16 inch. Seam the turned under portion to the body of the piping 1/8 inch from the folded edge. c. Position the right side of the top ply of sleeve patch on the hemmed piping, with the raw edges of the sleeve patch in line with the piping stitching line. d. Join sleeve patch to the piping along the top, bottom and scalloped edge 1/8 inch from the inner edge of the piping. e. Trim and notch the outer edge of piping along the scalloped edge in order to prevent pulling and bulges on the edges. f. Position the top ply of sleeve patch on the under ply, face to face, with the outer edge of piping and raw edge of the under ply even.	301	EFa-1	12-16	A	A
		301	SSe-2 (a)	12-16	A (silk)	A (silk)

MIL-DTL-82156D(MC)

TABLE I. Manufacturing requirements - Continued.

NO	OPERATION	STCH TYPE	SEAM/ STCH TYPE	STCH/IN	NDL	BOB/ LPR
	g. Stitch along the top, bottom and scalloped edge, through all plies, 3/16 inch from the inner raw edge of the piping. Trim any excess material if necessary.	301	SSk-1 (a) (without cord)	12-16	A (silk)	A (silk)
	h. Turn the sleeve patches, working the piping out completely and forming smooth corners and point at the scalloped side edge.					
	i. Topstitch the sleeve patches uniformly, 3/16 inch from the folded edge of the piping.	301	SSk-1 (b) (without cord and top- stitched)	12-16	A (silk)	A (silk)
10	<u>Make ornamental sleeve patches.</u> (cont'd)					
	j. Press the sleeve patches smooth and flat with a heated pressing iron or pressing machine.					
	k. Mark each sleeve patch as indicated by the marks on patterns, for the location of three eyelets.					
	l. Make one eyelet at each mark through all plies of the sleeve patch for attaching insignia button.	Eyelet		22 per eyelet	A (silk)	A (silk)
11	<u>Stitch and press dart in under sleeves.</u>					
	a. Fold the under sleeve, matching the cut edges of the sleeve dart. Stitch the entire length of the dart 1/4 inch from the cut edges of the armhole, tapering the line of stitching to zero at the lower folded edge.	301	SSa-1 (cut edges) OSf-1 (folded edge)	12-16	A	A
	b. Turn the cut edges of the dart toward the forearm edge and press the entire dart smooth and flat with a heated pressing iron.					
12	<u>Seam sleeves at forearm.</u> Finished appearance. The forearm seam shall finish smooth and flat without twists, gathers, puckers, or pleats and shall start and finish evenly.					

MIL-DTL-82156D(MC)

TABLE I. Manufacturing requirements - Continued.

NO	OPERATION	STCH TYPE	SEAM/ STCH TYPE	STCH/IN	NDL	BOB/ LPR
	<p>a. Position the top sleeve with the upper forearm edge in line with the notch in the armhole edge of the under sleeve and with the notches in the lower forearm edge of top and under sleeves matching. Seam the top and under sleeves together 3/8 inch from forearm edge of the top sleeve, forming a tapered outlet on the under sleeve.</p> <p>b. Spread open the seam and press flat with a heated pressing iron.</p>	301	SSbd-1 and SSa-1	12-16	A	A
12	<u>Seam sleeves at forearm.</u> (cont'd)					
	<p>c. Mark the sleeve end for turnup and mark the top sleeve for positioning the ornamental sleeve patch with pattern marker.</p>					
13	<u>Baste wigan reinforcement to sleeve.</u>					
	<p>a. Position the sleeve on the wigan reinforcement piece with marks and notches matching.</p> <p>b. Baste the sleeve and wigan piece together at the mark for the bottom turnup.</p>					
14	<u>Join ornamental sleeve patches to top sleeves.</u>	Hand or 101				
	<p>Finished appearance. The ornamental sleeve patch shall be uniformly stitched to the top sleeve without twists, gathers, puckers, pleats or raw edges. The folded front edge of the patch shall not be topstitched. The dimensions and position of the ornamental sleeve patch shall be as shown in Figure 4. The scalloped edge of sleeve patch shall be stitched to the sleeve at the corners and point only, in order to facilitate removal of insignia buttons when pressing coat.</p>					

MIL-DTL-82156D(MC)

TABLE I. Manufacturing requirements - Continued.

NO	OPERATION	STCH TYPE	SEAM/ STCH TYPE	STCH/IN	NDL	BOB/ LPR
	a. Mark the ornamental sleeve patch on the under ply 1/4 inch from the raw edge. Position the sleeve patch on the sleeve with marks matching and with the bottom edge of the sleeve patch even with the mark for the bottom turnup of the sleeve.					
	b. Seam the sleeve patch to the sleeve at the mark.	301	LSa-1	12-16	A (silk)	A (silk)
14	<u>Join ornamental sleeve patches to top sleeves.</u> (cont'd)					
	c. Turn back the sleeve patch at the seamline and stitch through the sleeve and wigan along the upper and bottom piped edges. The line of stitching shall be adjacent to the stitching line of the sleeve patch piped edge and shall extend from the turned edge to approximately 1/2 inch over the pointed ends. At the center point, the stitching shall extend approximately 1/2 inch on each side of the point.	301	LSbj-1	12-16	A (silk)	A (silk)
15	<u>Seam sleeves at backarm.</u> Finished appearance. The backarm seam shall finish smooth and flat without twists, gathers, puckers, or pleats and shall start and finish evenly.					
	a. Join the top and under sleeves together at the backarm with a 3/8 inch seam, catching the ends of the wigan reinforcement piece in the stitching.	301	SSa-1	12-16	A	A
	b. Spread open the seam and press smooth and flat with a heated pressing iron.					
16	<u>Baste and tack sleeve turnup to reinforcement.</u> a. Turn up the bottom edge of the sleeve to the inside at the mark. Baste along the turned edge.					

MIL-DTL-82156D(MC)

TABLE I. Manufacturing requirements - Continued.

NO	OPERATION	STCH TYPE	SEAM/ STCH TYPE	STCH/IN	NDL	BOB/ LPR
	b. Tack the raw edge of the turned-up portion to the reinforcement wigan piece with blind stitching.	Hand or 101 or 301 or Hand	Efc-1	4-6 4-6	A (silk)	C (silk)
17	<u>Stitch and press dart in under sleeve linings.</u>					
	a. Fold the under sleeve lining, matching the cut edge of the under sleeve dart. Stitch the entire length of the dart, 1/4 inch from the cut edges of the armhole, tapering the line of stitching to zero at the lower folded edge.	301	SSa-1 (cut edges) OSf-1 (folded edge)	12-16	A	A
	b. Turn the cut edges of the dart toward the forearm edge and press the entire dart smooth and flat with a heated pressing iron.					
18	<u>Seam sleeve lining at forearm.</u>					
	Finished appearance. The forearm seam shall finish smooth and flat without twists, gathers, puckers, or pleats and shall start and finish evenly.					
	a. Position the top sleeve lining with upper forearm edge in line with the notch in the armhole edge of under sleeve lining. With the notches at lower forearm edge of top and under sleeve lining matching, seam the top and under sleeve lining together, 3/8 inch from the forearm edge of top sleeve lining, forming a tapered outlet on the under sleeve lining.	301	SSbd-1 and SSa-1	12-16	A	A
19	<u>Seam sleeve lining at backarm.</u>					
	Finished appearance. The backarm shall finish smooth and flat without twists, gathers, puckers, or pleats and shall start and finish evenly.					
	a. Join the top and under sleeve linings at the backarm with a 3/8 inch seam.	301	SSa-1	12-16	A	A

MIL-DTL-82156D(MC)

TABLE I. Manufacturing requirements - Continued.

NO	OPERATION	STCH TYPE	SEAM/ STCH TYPE	STCH/IN	NDL	BOB/ LPR
20	<u>Assemble sleeve and sleeve lining.</u> Finished appearance. The lining shall be seamed to the sleeve without twists, gathers, puckers, or pleats.					
20	<u>Assemble sleeve and sleeve lining.</u> (cont'd) a. Position the sleeve lining on the sleeve with the upper edge of the lining extended approximately 1 inch beyond the armhole edge of the sleeve. b. Tack the sleeve lining to the forearm and backarm seam allowance, respectively, of the top sleeve, commencing at the top edge of the wigan reinforcement piece and extending to approximately 6 inches from armhole edge at backarm and approximately 4-1/2 inches from armhole edge at the forearm. c. Pull sleeve through lining.	301 or Hand	SSa-1	6-8 4-6	A (silk) A	C (silk)
21	<u>Fell turnup of sleeve lining.</u> Finished appearance. The sleeve lining shall not be short, tight, or twisted at the bottom of the sleeve. a. Turn under the bottom edge of sleeve lining to finish 1 to 1-1/4 inches above the finished end of sleeve. Baste to turnup of the sleeve, or, the sleeve lining may be felled to bottom sleeve without basting. b. Fell the folded edge of the sleeve lining to the turnup of the sleeve with blind stitching.	Hand or 101				
		Hand or 301	EFC-1 (b)	8-10 6-8	C (silk) 0 (silk)	0 (silk)
22	<u>Press sleeves.</u> a. Turn the sleeves right side out and assemble in pairs. Press the lower half of the sleeves smooth and flat, creasing at the forearm and backarm. The backarm crease shall be on the backarm seam. Remove the basting at lower end of the sleeve.					

MIL-DTL-82156D(MC)

TABLE I. Manufacturing requirements - Continued.

NO	OPERATION	STCH TYPE	SEAM/ STCH TYPE	STCH/IN	NDL	BOB/ LPR
23	<p><u>Assemble collar interlining.</u></p> <p>Finished appearance. The interlining is made of one ply of plastic (mylar), one ply of laminated buckram and one ply of polyester twill or plain weave cloth. The interlining shall be constructed without twists, pleats or distortions.</p> <p>a. Position the plastic, buckram and twill or plain cloth together and join with a 1/8 inch seam on the upper and lower edges. The interlining shall finish with the twill cloth on the inside and the plastic on the outside (see Figure 5).</p> <p>b. Lap the raw edge of the collar eyelet cover 1/2 to 5/8 inch on the top inside edge of collar interlining. Seam the covers to the interlining 1/4 inch from the raw edge of the cover. In the finished coat, the collar eyelet covers shall be centered over the collar eyelet.</p>	301	BSa-1 (each edge)	12-16	A	A
24	<p><u>Pipe outer ply of collar.</u></p> <p>Finished appearance. The piping shall extend at upper, lower, and side edges of the outer ply. It shall be uniformly stitched without twists, gathers, puckers or pleats.</p> <p>a. The outer ply of the collar shall consist of two plies of basic material, piped at the upper edge with the vinyl cord and lower edge with 5/8 to 3/4 inch wide strip of the piping material specified in 3.3.11.</p> <p>b. Position the two plies of the collar face up and edges even. Stitch them together from end to end, 1/8 inch from the upper and lower edges.</p>					

MIL-DTL-82156D(MC)

TABLE I. Manufacturing requirements - Continued.

NO	OPERATION	STCH TYPE	SEAM/ STCH TYPE	STCH/IN	NDL	BOB/ LPR
	c. Seam the 5/8 to 3/4 inch wide strip of piping to the lower edge of the two plies of collar from end to end, 1/8 inch from the upper and lower edges. Seam the vinyl cord to the upper collar edge.	301	SSe-2	12-16	A (silk)	A (silk)
24	<u>Pipe outer ply of collar.</u> (cont'd)					
	d. Turn back the piping and outer ply at upper and lower edges, uniformly working the folded edge of the piping beyond the edges. Topstitch the outer ply uniformly 3/16 inch from the folded edge of piping.	301	BSm-3 (b)	12-16	A (silk)	A (silk)
25	<u>Assemble collar.</u>					
	Finished appearance. The collar shall be assembled without twists, gathers, puckers or pleats. In the finished collar, the end of the lining shall extend approximately 1/2 inch beyond the right end of collar and approximately 2-1/2 inches beyond the left end of the collar for the extension tab. The eyelet cover shall not be caught in the eyelet.					
	a. Position the upper piped edge of collar 1/8 inch below the upper bound edge of collar interlining with lower edges of collar and collar interlining even. The collar shall extend approximately 1 inch beyond each end of collar interlining.					
	b. Stitch collar to interlining along the upper and lower piped edge from edge to end. The line of stitching shall be adjacent to stitching of the piped collar edge, catching the eyelet cover in the stitching.	301	SSa-1	12-16	A (silk)	A (silk)

MIL-DTL-82156D(MC)

TABLE I. Manufacturing requirements - Continued.

NO	OPERATION	STCH TYPE	SEAM/ STCH TYPE	STCH/IN	NDL	BOB/ LPR
	<p>c. Lap the upper piped edge of collar assembly over the upper raw edge of lining, approximately in half, with the lining facing up. Stitch collar to lining and eyelet cover along piped edge adjacent to stitching line of the collar piped edge. The stitching shall extend from center to center of the eyelet covers.</p> <p>d. Smoothly fold the ends of the collar padding and outer ply to the inside over the ends of the interlining assembly, and press smooth and flat with a heated pressing iron or pressing machine.</p>	301	LSa-1	12-16	A	A
25	<u>Assemble collar.</u> (cont'd)					
	<p>e. Turn the collar lining at the seams to the inside of the collar and press smooth and flat with a heated pressing iron or pressing machine.</p>					
26	<u>Make collar extension tab.</u>					
	<p>Finished appearance. The collar extension tab shall extend 3/4 to 7/8 inch beyond the folded edge of the left end of the collar.</p> <p>a. Turn the top and bottom edges and the end of the collar lining at the left end of the collar to the inside of the lining. Baste the turned portion along the top, front, and bottom edges to the body of the lining, forming the collar extension tab.</p>	Hand				
	<p>b. Stitch the collar extension tab 1/16 inch from the top, front, and bottom edges. Continue the stitching at the back of the tab to top row, forming a 1-3/8 to 1-1/2 inch wide box stitch.</p>	301	SSc-1 (top and bottom edges) OSf-1 (front) SSa-1 (back edge)	12-16	A (silk)	A (silk)

MIL-DTL-82156D(MC)

TABLE I. Manufacturing requirements - Continued.

NO	OPERATION	STCH TYPE	SEAM/ STCH TYPE	STCH/IN	NDL	BOB/ LPR
27	<p><u>Fell ends of collar.</u></p> <p>Finished appearance. The upper and lower piped edges of the collar at each end shall not be visible on the outside of the finished collar.</p> <p>a. Fold the ends of collar to the inside, against the end of interlining. Tack the collar to reinforcement pieces and eyelet covers with overcast stitching.</p> <p>b. Insert one metal eyelet, through all plies of the collar, midway between the upper and bottom edge and $1-1/2 \pm 1/8$ inches from the folded edge of either end of the collar.</p>	Hand		2-3	C (silk)	
28	<p><u>Fold and stitch dart in front lining.</u></p> <p>Finished appearance. The darts shall finish without gathers, puckers or pleats. The stitching shall be 3/8 inch from the folded edge at the center.</p> <p>a. Fold the front lining and stitch waist darts in accordance with marks indicated on the pattern. Taper the upper and lower ends to a flat point, and securely tack the points.</p>	301	OSf-1	12-16	A	A
29	<p><u>Sew on identification label.</u></p> <p>Finished appearance. The identification label shall be positioned so that, in the finished coat, the label shall be midway between front and back edges of the right facing, with the bottom edge of the label approximately 4 inches from the bottom finished edge of coat.</p> <p>a. Sew the identification label to the outside of the right facing with a single row of stitches, 1/16 inch from each edge.</p>	301	SSa-1 (each edge)	12-16	A	A

MIL-DTL-82156D(MC)

TABLE I. Manufacturing requirements - Continued.

NO	OPERATION	STCH TYPE	SEAM/ STCH TYPE	STCH/IN	NDL	BOB/ LPR
30	<u>Join front lining to wool facing.</u> Finished appearance. The lining shall be carefully joined to the facing so that, in the finished coat, the lining shall be smooth and flat along the facing without creases, bulges, overlapping of excess material, or other distortion. a. Position the lining on the wool facing with the top edges even. b. Seam front edges of the lining to the back edge of the facing 3/8 inch from the edge. The stitching shall extend from top edge of facing to approximately 1-1/4 inches from the bottom edges.	301	SSa-1	12-16	A	A
31	<u>Assemble back lining.</u> Finished appearance. The side back lining shall be carefully joined without gathers, puckers or pleats. The seams shall start and finish evenly. a. Position and join the left and right side back linings to the respective center backs lining with a 3/8 inch seam. b. Position the backs and join them together at the center with a 3/8 inch seam.	301 301	SSa-1 SSa-1	12-16 12-16	A A	A A
32	<u>Join side back and front linings.</u> Finished appearance. The side back and front linings shall be carefully joined without gathers, puckers or pleats. The seams shall start and finish evenly. a. Position and join the front and side back linings at the sides with a 3/4 inch seam.	301	SSa-1	12-16	A	A
33	<u>Overedge stitch lining and facing seams.</u> a. Overedge stitch together the raw edges of the facing lining, side, side back, and center back seam allowance.	503 or 504	SSa-1	6-8 6-8	70/2 70/2	70/2 70/2

MIL-DTL-82156D(MC)

TABLE I. Manufacturing requirements - Continued.

NO	OPERATION	STCH TYPE	SEAM/ STCH TYPE	STCH/IN	NDL	BOB/ LPR
34	<u>Press lining seams and waist darts.</u> a. Turn the edge of facing-lining seam, the side seams, and side back seams toward the back and press smooth and flat. b. Turn the waist darts toward the side seam and press smooth and flat.					
35	<u>Assemble fronts.</u> Finished appearance. The chest and waist darts shall finish without gathers, puckers or pleats. The stitching for the waist darts shall be 3/8 inch from the folded edge at the center.					
35	<u>Assemble fronts.</u> (cont'd) a. Fold the fronts, matching the notches of the chest darts. Stitch the entire length of the darts 3/8 inch from the notches at the upper end, tapering the line of stitching to zero at the lower end. b. Fold the fronts and stitch the waist dart in accordance with the marks indicated on the pattern. Taper the upper and lower ends to a flat point and securely tack the points.	301	SSa-1 (cut edge) OSf-1 (folded edge)	12-16	A	A
		301	OSf-1	12-16	A	A
36	<u>Press darts on fronts.</u> a. Turn the folded edge of the chest darts towards the armhole and press smooth and flat. b. Turn the folded edge of the waist darts towards the armhole and press smooth and flat.					
37	<u>Assemble back.</u> Finished appearance. The side and center backs shall be joined without gathers, puckers or pleats. The seams shall start and finish evenly. a. Position the center back with notches matching and join with a 5/8 inch seam.	301	SSa-1	12-16	A	A

MIL-DTL-82156D(MC)

TABLE I. Manufacturing requirements - Continued.

NO	OPERATION	STCH TYPE	SEAM/ STCH TYPE	STCH/IN	NDL	BOB/ LPR
38	<p>b. Position and join the left and right side backs to the respective center back with a 3/8 inch seam.</p> <p><u>Join fronts and back.</u></p> <p>Finished appearance. The fronts and back shall be joined without gathers, puckers or pleats. The seam shall start and finish evenly.</p>	301	SSa-1	12-16	A	A
39	<p>a. Position and join the fronts to the back at the sides with a 3/4 inch seam.</p> <p><u>Overedge stitch front and back seams.</u></p> <p>a. Overedge stitch all raw edges of the joining seams for front and back.</p> <p>b. Spread open the side and back seams and press smooth and flat with a heated pressing iron.</p>	301	SSa-1	12-16	A	A
40	<p>a. Overedge stitch all raw edges of the joining seams for front and back.</p> <p>503 or 504</p> <p>Efd-1 Efd-1</p> <p>6-8 6-8</p> <p>70/2 70/2</p> <p>70/2 70/2</p> <p>b. Spread open the side and back seams and press smooth and flat with a heated pressing iron.</p> <p><u>Seam reinforcement stay to armhole and shoulder.</u></p> <p>Finished appearance. The polyester and cotton reinforcement stays shall be sewn to the armhole and shoulder edges of the fronts without gathers, puckers or pleats. The top end of the armhole stay and lower edge of the shoulder stay shall form a right angle at the armhole without the stays overlapping each other.</p> <p>a. Seam the 3/4 inch wide stay to the shoulder edges and upper front edges of the armhole, 1/8 inch from the outer edges. The stay at the armhole shall extend from 1/2 inch below the shoulder seam down the front edge of the armhole approximately 4-1/2 inches; the stay at the shoulder shall extend approximately 1/2 inch from armhole and neck.</p>	503 or 504	Efd-1 Efd-1	6-8 6-8	70/2 70/2	70/2 70/2
	<p>a. Seam the 3/4 inch wide stay to the shoulder edges and upper front edges of the armhole, 1/8 inch from the outer edges. The stay at the armhole shall extend from 1/2 inch below the shoulder seam down the front edge of the armhole approximately 4-1/2 inches; the stay at the shoulder shall extend approximately 1/2 inch from armhole and neck.</p>	301	SSaa-1	12-16	A	A

MIL-DTL-82156D(MC)

TABLE I. Manufacturing requirements - Continued.

NO	OPERATION	STCH TYPE	SEAM/ STCH TYPE	STCH/IN	NDL	BOB/ LPR
41	<p><u>Tape armholes.</u></p> <p>a. Sew the cotton tape to the armhole. Start with one end approximately 1 inch above the notch in the fronts and continue along the lower and back edge of the armhole to approximately 1/2 inch from the shoulder edge.</p> <p>b. The tape shall be stitched with slight tension along the lower front edges of the armhole and shall be held taut while stitching along the back edge.</p>	301	SSaa-1	12-16	A	A
42	<p><u>Press shoulder blades and armhole tapes.</u></p> <p>a. Press the shoulder blades and the armhole tape smooth and flat with a heated pressing iron or suitable type pressing machine.</p>					
43	<p><u>Mark and dress left front.</u></p> <p>a. Mark and shape the left front edge from the top notch to the bottom front notch.</p> <p>b. The mark line shall be 1 inch from the upper edge to 1-1/8 inches at the waist line. Continue on a straight line from the waist line to the notch at the bottom edge.</p> <p>NOTE: The dressing and shaping shall be performed in the sewing room.</p> <p>c. Where necessary, trim any frayed edges along the right front and bottom edges.</p>					
44	<p><u>Stitch piping to coat.</u></p> <p>Finished appearance. The piping shall be uniformly stitched to the coat without twists, gathers, puckers or pleats. The piping shall extend from the collar notch at top edge of the right front, along the bottom and up to the collar notch at the top edge of the left front.</p>					

MIL-DTL-82156D(MC)

TABLE I. Manufacturing requirements - Continued.

NO	OPERATION	STCH TYPE	SEAM/ STCH TYPE	STCH/IN	NDL	BOB/ LPR
	a. Position the 1 inch wide strip of piping material on the outside of left and right fronts, with edges even with top, front, and bottom edges of coat. Stitch piping to coat 1/8 inch from edge. The piping shall extend from bottom right front edge to the collar notch at the top edge of left front.	301	SSa-1	12-16	A (silk)	A (silk)
44	<u>Stitch piping to coat.</u> (cont'd)					
	b. Turn the piping to the inside, fold-ing the corners smooth and flat, and working out the folded edge of piping uniformly, 1/8 inch beyond the edges of the coat. Topstitch the piped edges of the coat uniformly 3/16 inch from the folded edge of the piping, catching the turned under portion of the piping in the stitching.	301	SSe-2 (b)	12-16	A (silk)	A (silk)
	c. Cut out any excess piping material at the top and bottom front corners to eliminate bulkiness. Trim the inner edge of piping on the left front only, from the upper front down to approximately 1-1/2 to 2 inches below the waistline, so that the piping will not interfere with front of the buttonholes.					
	d. Serge stitch the raw edge of the piping at the bottom edge of the coat.	503 or 504	EFd-1 EFd-1	6-8 6-8	70/2 70/2	70/2 70/2
	e. Press the piped edge of the coat smooth and flat with a heated pressing iron or pressing machine.					
45	<u>Interline fronts.</u>					
	a. Position the left and right fronts on the respective coat front interlinings. Baste the interlinings and fronts together from approximately 3-1/2 inches down from the shoulder edge to approximately 2 inches up from the bottom edge of the front.	Hand or 301	Hopper			

MIL-DTL-82156D(MC)

TABLE I. Manufacturing requirements - Continued.

NO	OPERATION	STCH TYPE	SEAM/ STCH TYPE	STCH/IN	NDL	BOB/ LPR
45	<p><u>Interline fronts.</u> (cont'd)</p> <p>b. Baste along the shoulder, allowing room for setting the shoulder pad, working the fullness in the front towards the armhole. Baste along the front of the armhole approximately 1 inch from the edge. Continue to baste down the back edge of interlining, across the waist dart, to approximately 2 inches from the bottom edge of fronts. Baste along the top edge from the basting stitches for the shoulder to approximately 1-1/2 inches from the front edge. Continue to baste approximately 1-1/2 inches from the front edge to the bottom edge of fronts.</p>	Hand or 301	Hopper			
46	<p><u>Trim coat front interlining.</u></p> <p>a. Trim the top edge of coat interlining even with the top edge of fronts, from the point of the shoulder to the collar notch.</p> <p>b. Notch the top edge of the interlining in line with the collar notch.</p> <p>c. Remove the stitches joining the front edge of polyester and cotton cloth to coat front interlining, approximately 1/2 inch back from front and top edge of the fronts.</p> <p>d. Trim the interlining only, even with the front and bottom edges of the fronts.</p> <p>e. Turn the fronts inside out and trim the interlining only, approximately 1/4 inch back from the front and top edge of fronts.</p> <p>f. Trim the shoulder edge of the coat front interlining to approximately 3/4 inch from shoulder at armhole edge of fronts; taper the trimming to 3/8 inch at the neck.</p>					

MIL-DTL-82156D(MC)

TABLE I. Manufacturing requirements - Continued.

NO	OPERATION	STCH TYPE	SEAM/ STCH TYPE	STCH/IN	NDL	BOB/ LPR
47	<u>Bind front and top edge of interlining.</u> a. Smoothly fold the polyester and cotton, at the top and front edge of the interlining, over the respective raw edges to the underside. Secure the front turned under portion of the polyester and cotton to the body of the interlining with three rows of stitches 1/4 inch apart. Place the first row 1/8 inch from folded front edge and catch the upper turned under portion in the stitching.	301	EFa-1	12-16	A	A
48	<u>Bind top neck edge of interlining.</u> Finished appearance. The polyester and cotton binding shall be uniformly stitched to the top edge of the coat front interlining from the collar notch to the shoulder point. a. Lap the 3/4 inch wide binding on the outside of the coat front interlining, from the collar notch to the shoulder point, approximately 1/4 inch. Stitch the binding to the interlining, 1/8 inch from the raw edge of the binding. b. Smoothly fold the free edge of the binding over the top edge and to the underside of the interlining. Secure the free edge of binding to the interlining with a row of stitches 1/8 inch from the raw edge of the binding.	301	LSa-1	12-16	A	A
		301	BSa-1	12-16	A	A
49	<u>Fell piping to coat front interlining.</u> a. Place the inner edge of the piping on the outside of the interlining at the top, front, and bottom edges. Baste piping to the interlining through the fronts. b. Fell the upper front and lower inner edge of the piping to the coat front interlining. c. Pull tab and remove basting stitches from the piping.	101				
		301 or Hand	EFc-1	4-6 4-6	A (silk) A	C (silk)

MIL-DTL-82156D(MC)

TABLE I. Manufacturing requirements - Continued.

NO	OPERATION	STCH TYPE	SEAM/ STCH TYPE	STCH/IN	NDL	BOB/ LPR
49	<u>Fell piping to coat front interlining.</u> (cont'd) d. Press the left and right fronts on a suitable type pressing machine. The chest to conform to the shape of the body.					
50	<u>Set belt loops.</u> Finished appearance. The belt loops shall finish vertically straight. a. Center the belt loops vertically on the side seam with the pointed end towards the bottom of the coat and with the raw edge of the loop in horizontal alignment with the mark for the bottom buttonhole as indicated, by the pattern. b. Seam the loops to the coat 1/4 inch from the raw edge. c. Turn the loop at the seam, with the pointed end towards the top edge of coat, and secure the loop to the coat with a row of stitches 1/4 inch from the raised edge.	301 301	LSq-2 (a) LSq-2 (b)	12-16 12-16	A (silk) A (silk)	A (silk) A (silk)
51	<u>Join facing to fronts.</u> a. Position the left and right fronts to the respective front facings (face to face) with the waistline notch of the front in line with the notch on the facing and with the front piped edge approximately 3/8 inch from the front edge of facing. Mark the facing along the top, front, and bottom edge of the coat. b. Lap the front edge of the right and left fronts on the outside of the facing at the respective marks. Join the front and facing as close as possible to, but not on top of, the stitching, joining the piping to the front. The stitching shall extend from top to bottom edge of coat front edge only. c. Trim excess facing material where necessary.	301	LSa-1	12-16	A (silk)	A (silk)

MIL-DTL-82156D(MC)

TABLE I. Manufacturing requirements - Continued.

NO	OPERATION	STCH TYPE	SEAM/ STCH TYPE	STCH/IN	NDL	BOB/ LPR
52	<p><u>Join front eyelet cover to right facing.</u></p> <p>a. Mark the outside of the right facing 1/2 inch from the seam joining facing to the front. Mark the upper edge of facing in such a manner that the front corner of the eyelet cover shall finish approximately 1/4 inch down from the folded edge of piping.</p> <p>b. Lap the front raw edge of the eyelet cover on the outside of the right facing at the marks. Seam the eyelet cover to the facing only, 1/4 inch from raw edge of eyelet cover.</p> <p>c. Turn back the eyelet cover at the seam and topstitch the cover through the facing only, 1/8 to 3/16 inch from the raised edge.</p>	301	LSq-1 (a)	12-16	A (silk)	A (silk)
		301	LSq-1 (a)	12-16	A (silk)	A (silk)
53	<p><u>Baste front edges.</u></p> <p>a. Turn the facing-lining assemblies to the inside of fronts. Baste along the front edge of the left and right fronts, working the facing back from the folded edge of the piping.</p>	101				
54	<p><u>Baste facing (second time).</u></p> <p>a. Baste the facing to the fronts approximately 1-1/4 inches from the top, front, and bottom edges of the coat, holding the lower corner of the coat in such a manner as to cause the lower front edge of the fronts to roll inward towards the back edge of the facing.</p> <p>b. Turn under and baste the top edge of the facing to the fronts from the collar notch to the front edge, catching the turned under portion of the facing to the basting.</p>	Hand or 301	Hopper			
		Hand or 301	Hopper			

MIL-DTL-82156D(MC)

TABLE I. Manufacturing requirements - Continued.

NO	OPERATION	STCH TYPE	SEAM/ STCH TYPE	STCH/IN	NDL	BOB/ LPR
54	<u>Baste facing (second time).</u> (cont'd) c. Baste the facing to the fronts as close as possible to the facing-lining seam, placing the fullness over the chest and distributing the fullness in the facing in accordance with good commercial practice. The basting shall extend approximately 3 inches from shoulder edge of the facings to approximately 1-1/4 inches from the lower edge of the facing. d. Turn under the bottom edge of the facing at the mark and baste along the folded edge.	Hand or 301	Hopper			
55	<u>Tack facings to interlining.</u> a. Tack the right and left facing-lining seam allowance to the respective coat front interlining from approximately 2-1/2 inches from bottom edge of coat to approximately 3 inches from the shoulder edge.	Hand or 103	SSm-1	2-6 4-6	C (silk) A (silk)	
56	<u>Baste linings to coat.</u> a. Fold the front lining in accordance with the notches, forming the chest pleat, and baste along the entire center of the pleat. The folded edge of the pleat on the outside of the lining shall be towards the armhole. b. Baste the front lining to the coat, starting at the lower end of chest pleat, continuing along the lower edge of armhole approximately 2 inches from the edge, and ending at the side seam. Match the side seams of coat and lining. Continue basting as close as possible to the side seam and then across the bottom towards the front, approximately 4 inches from piped bottom edge of coat.	Hand or 301	Hopper			

MIL-DTL-82156D(MC)

TABLE I. Manufacturing requirements - Continued.

NO	OPERATION	STCH TYPE	SEAM/ STCH TYPE	STCH/IN	NDL	BOB/ LPR
56	<u>Baste linings to coat.</u> (cont'd) c. Fold the back lining, forming an approximately 1 inch wide pleat at the center back. Baste the back lining to the coat along the center pleat from the top end to approximately 4 inches from the bottom finished edge of coat. d. Baste back lining to coat. Start at side seam and continue approximately 3 inches from the armhole and shoulder edges.	Hand or 301	Hopper			
57	<u>Hem bottom edge of lining.</u> Finished appearance. The hem shall be uniformly stitched and shall finish smooth and flat without twists, gathers, puckers or pleats. The hem shall be $3/4 \pm 1/8$ inch wide. The lining securing straps shall be positioned on the side seam outlets of the lining with one edge even with the serged edge. a. Hem the bottom edge of body lining with the raw edge turned under and with one end of the securing straps positioned and caught in the stitching, 1/16 inch from the upper folded edge of hem.	301	EFb-1	12-16	A	A
58	<u>Tack the lining securing straps to bottom of coat.</u> Finished appearance. The lining securing straps when tacked to the bottom edge of coat shall not cause twists or other distortions to either the coat or the lining. The end of the securing straps shall finish between the piping at bottom edge of coat and side seam allowance. In the finished coat, the lining shall not be visible below the bottom edge of coat. a. Position and securely tack the free end of the securing straps to the piping at the bottom edge of coat through the side seam allowance.	301	SSbh-3	12-16	A	A

MIL-DTL-82156D(MC)

TABLE I. Manufacturing requirements - Continued.

NO	OPERATION	STCH TYPE	SEAM/ STCH TYPE	STCH/IN	NDL	BOB/ LPR
58	<u>Tack the lining securing straps to bottom of coat.</u> (cont'd) b. Position the bottom edge of the lining so that, in the finished coat, the lining shall not be visible below the bottom edge of the coat. Fold the lining securing straps across the width and stitch approximately 1/4 inch from the folded end in order to hold the lining in position.	301	OSf-1	6-10	A	A
59	<u>Fell facings.</u> a. Fell the facing to the piping at the bottom edge of the coat. Start at the bottom edge of the lining and continue along the back and bottom edges of the facing to the front edge of the coat. b. Fell the folded edge of the facings to the piping along the top edge from the collar notch to front edge of the coat.	Hand		8-10	C (silk)	
		Hand		8-10	C (silk)	
60	<u>Trim lining and interlining.</u> a. Trim the excess coat front interlining and front lining at the armhole. b. Trim back lining even at the neck. c. Trim the shoulder edge of the front and back lining to approximately 3/4 inch from shoulder at the armhole edge and taper the trimming to 3/8 inch at the neck.					
61	<u>Baste shoulder pad to coat.</u> a. Insert shoulder pads between interlining and chest padding of coat fronts. Securely tack the pads to the interlining and chest padding only.	Hand or 301	Hopper			
62	<u>Seam shoulders.</u> Finished appearance. The shoulder seam shall finish without a distorted appearance.					

MIL-DTL-82156D(MC)

TABLE I. Manufacturing requirements - Continued.

NO	OPERATION	STCH TYPE	SEAM/ STCH TYPE	STCH/IN	NDL	BOB/ LPR
62	<u>Seam shoulders.</u> (cont'd)					
	a. Join the back to the fronts at the shoulders with a 3/8 inch seam, working in the fullness on the back in accordance with good manufacturing practice.	301	SSa-1	12-16	A	A
	b. Spread open the shoulder seam and press flat, holding the shoulders short and exercising much care in pressing in order not to effect a distorted appearance in the finished seam. The pressing shall be accomplished with a heated pressing iron or pressing machine over a suitable block.					
	c. Position the front lining and coat front interlining at the neck, shoulder and armhole edges of the fronts. Baste all plies together along the front edge of armhole. Continue along the shoulder seam and gorge, catching the shoulder pad in the basting.	Hand or 301	Hopper			
63	<u>Set shoulder straps.</u>					
	Finished appearance. The shoulder straps shall be uniformly stitched to the coat without twists, puckers, pleats or other distortion. On the finished coat, the straps, including the piping, shall be 2-3/8 ± 1/8 inches wide at the armhole seam and shall taper to 1-3/4 ± 1/8 inches wide at the buttonhole eyelet end.					
	a. Position the shoulder straps with the back edge 1/4 to 1/2 inch to the back of the shoulder seam at the armhole and with the rounded end of the straps, on the finished coat, 1/4 to 3/8 inch from lower edge of the collar.					
	b. Seam the shoulder straps to the coat 3/8 inch from the armhole edge. Trim the shoulder straps even with the armhole where necessary. Turn the coat on the inside.	301	SSa-1	12-16	A (silk)	A (silk)

MIL-DTL-82156D(MC)

TABLE I. Manufacturing requirements - Continued.

NO	OPERATION	STCH TYPE	SEAM/ STCH TYPE	STCH/IN	NDL	BOB/ LPR
64	<p><u>Baste back lining and facing-lining assembly at shoulders.</u></p> <p>a. Turn under and lap the shoulder edge of the back lining on the facing-lining assembly. Baste the lining to the coat along the folded edge of the back lining with the top end of the chest pleat caught in the basting.</p>	Hand				
65	<p><u>Seam neckline with size label and coat hanger:</u></p> <p>Finished appearance. The neckline shall finish smooth and flat, without twists, pleats or puckers. The size label shall be positioned between the ends of the coat hanger and the ends of the coat hanger shall be positioned so that, in the finished coat, the hanger opening shall be $2 \pm 1/8$ inches long when measured along the lower edge of the collar lining.</p> <p>a. Join the facings and back lining to coat at the neckline, from collar notch to collar notch, with a 1/4 inch seam and with the upper edge of the size label and the ends of the hanger positioned and caught in the stitching at the inside center back.</p> <p>b. Press the neckline of the coat smooth and flat with a heated pressing iron or pressing machine.</p>	301	SSa-1	12-16	A	A
66	<p><u>Set collar with lining.</u></p> <p>Finished appearance. The collar shall be carefully joined to the coat without distortion of the collar.</p> <p>a. Mark the neckline on the inside, 3/8 to 1/2 inch from top edge, for proper positioning of collar.</p> <p>b. Position the collar with the lower edge lapped on the outside top edge of the coat at the mark.</p>					

MIL-DTL-82156D(MC)

TABLE I. Manufacturing requirements - Continued.

NO	OPERATION	STCH TYPE	SEAM/ STCH TYPE	STCH/IN	NDL	BOB/ LPR
66	<u>Set collar with lining.</u> (cont'd) c. Seam the collar, from end to end, to the coat as close as possible to, but not on top of, the stitching for the piping at the lower edge of the collar. The stitching shall not be through the collar lining.	301	LSa-1	12-16	A	A
67	<u>Make buttonholes.</u> Finished appearance. The buttonholes shall be clean cut, well made, well worked over gimp to fit 40-line insignia buttons. The stitching of the buttonholes shall be securely caught in the basic material. The gimp and thread shall be pulled through to the underside of the front. The purling of the buttonholes shall be on the outside of the fronts. The inside edge of the eyelet end of the buttonhole shall be 5/8 inch from the front edge of coat. The buttonholes shall be cut-first type. a. Mark the left front for the location of seven buttonholes. The marks for the top and bottom buttonholes shall be in accordance with the patterns. The marks for the remaining five buttonholes shall be evenly spaced. b. Make one horizontal, eyelet end, square-bar type buttonhole, cut 1-1/4 inches long, at each of the marks. c. Securely bartack the end of each buttonhole, catching the ends of the gimp and thread in the bartack. Trim the ends of the gimp and thread.	Button-hole		60 per button-hole (not incl. bartack)	B (silk)	F (silk)
		Bartack		21 per bartack	A (silk)	A (silk)
68	<u>Set sleeves.</u> Finished appearance. The armhole-sleeve seam shall finish without twists, gathers, puckers or pleats.					

MIL-DTL-82156D(MC)

TABLE I. Manufacturing requirements - Continued.

NO	OPERATION	STCH TYPE	SEAM/ STCH TYPE	STCH/IN	NDL	BOB/ LPR
68	<u>Set sleeves.</u> (cont'd) a. Position the sleeve on outside of coat at the armhole, with backarm seam of sleeve matching the side back seam, and with notch in the top sleeve and the front matching. b. Join the sleeve to the coat with a 3/8 inch seam, catching the end of the shoulder straps in the stitching. c. Press the entire armhole smooth and flat with a heated pressing iron. Exercise care not to stretch the armhole. Spread open upper part of the armhole-sleeve seam from the backarm seam of sleeve to approximately midway between shoulder seam and notch at front edge of armhole. Press smooth and flat with a heated pressing iron. d. Fold the excess material at the armhole pit up to the line of the stitching of the armhole sleeve seam, forming a hinge effect. The fold shall extend from the armhole notch to approximately 4 inches from the backarm seam. e. Press the fold smooth and flat with a heated pressing iron.	301	SSa-1	12-16	A	A
69	<u>Baste armhole.</u> a. Baste around the entire armhole on the inside, holding the back lining, shoulder pad and front lining in place and distributing fullness evenly. Turn the coat on the outside. b. Baste around the outside armhole adjacent to the armhole seam, forcing out the armhole in the basting. The basting shall extend from the backarm seam of the sleeve to the front notch of coat.	Hand				
70	<u>Set underarm shields.</u> a. Baste or tack underarm shields at the base of the armhole.	Hand or 301				

MIL-DTL-82156D(MC)

TABLE I. Manufacturing requirements - Continued.

NO	OPERATION	STCH TYPE	SEAM/ STCH TYPE	STCH/IN	NDL	BOB/ LPR
71	<p><u>Stitch sleeve-head pads and linings at armhole.</u></p> <p>Finished appearance. The armhole shall not be distorted or puckered due to stitching the sleeve-head pads and linings at the armhole.</p> <p>a. Position the sleeve-head pad on the sleeve with the folded edge of the pad approximately 1/8 inch back from the raw edge of the armhole-sleeve seam and with the one end of the pad matching the notch in the fronts.</p> <p>b. Stitch the sleeve-head pad to the sleeve front, end to end, through the armhole-sleeve seam allowance, 1/8 inch from the folded edge of the pad, catching the front and back linings and the shoulder pad in the stitching. Continue stitching the linings around the remainder of the armhole, catching the underarm shields in the stitching and trimming away the excess material.</p> <p>c. The underarm shield may be basted to the armhole prior to stitching.</p>	<p>Hand or 301</p> <p>301</p> <p>301</p>	<p></p> <p>SSa-1</p> <p>SSa-1</p>	<p></p> <p>4-6</p> <p>4-6</p>	<p></p> <p>A</p> <p>24/4</p>	<p></p> <p>A</p> <p>24/4</p>
72	<p><u>Tack underarm shield to lining.</u></p> <p>Finished appearance. The tacking for the underarm shield shall finish approximately 1/2 inch from the seamed edges.</p> <p>a. Tack the underside of the underarm shields to the body lining along the side and bottom edges.</p>	<p>Hand</p>		<p>4-6</p>	<p>C (silk)</p>	
73	<p><u>Fell back lining and facing-lining assembly at shoulders.</u></p> <p>a. Fell the back lining and facing-lining assembly together at the shoulders. Place the stitching over the folded edge of back lining and secure the top end of the chest pleat in the felling.</p> <p>b. Fell the folded edge of facing to the piping along the top edge from collar notch to front edge of coat.</p>	<p>Hand</p> <p>Hand</p>		<p>8-10</p> <p>8-10</p>	<p>C (silk)</p> <p>C (silk)</p>	

MIL-DTL-82156D(MC)

TABLE I. Manufacturing requirements - Continued.

NO	OPERATION	STCH TYPE	SEAM/ STCH TYPE	STCH/IN	NDL	BOB/ LPR
74	<p><u>Fell sleeve lining at armhole.</u></p> <p>a. Position the sleeve lining at the armhole with the back and forearm seams of the sleeve and sleeve lining matching.</p> <p>b. Turn under the armhole edge of the sleeve lining. Lap the lining on the outside of the front and back lining and the top edge of the underarm shield. Fell the sleeve lining to the coat around the entire armhole. Place the stitching over the folded edge of the sleeve lining, catching the underarm shield in the filling, and distribute the fullness in accordance with good commercial practice. Backstitch the lower armhole edge from the backarm seam of sleeve to the front edge of the shield.</p> <p style="text-align: center;">-or-</p> <p>c. Machine stitch the lower edge of the sleeve lining at the armhole, on the inside from forearm seam to backarm seam. Hand fell the remaining portion as specified in operation 74.b.</p> <p style="text-align: center;">-or-</p> <p>d. Machine stitch the lower edge of the sleeve lining at the armhole, on the inside, from forearm seam to backarm seam. Stitch the remaining portion of the sleeve lining at the armhole with machine simulated hand felling.</p> <p>NOTE: It is required that the simulated hand felling produced by machine shall be equal to or better than the hand felling.</p>	Hand		8-10	C (silk)	
		301	SSa-1	12-16	A	A
		Machine		8-10	C (silk)	

MIL-DTL-82156D(MC)

TABLE I. Manufacturing requirements - Continued.

NO	OPERATION	STCH TYPE	SEAM/ STCH TYPE	STCH/IN	NDL	BOB/ LPR
75	<u>Mark for eyelets in shoulders.</u> a. Mark each shoulder for the location of one eyelet for removable insignia buttons to align with the eyelet of buttonhole in the shoulder strap. On the finished coat, the shoulder strap shall lie smooth and flat without twisting or bulging.					
76	<u>Make eyelets.</u> Finished appearance. The eyelet shall be well worked with purling of the eyelet on the outside of the shoulder. The eyelets shall finish with a 1/8 to 3/16 inch diameter opening. a. Make one eyelet at the mark on each shoulder through all plies.	Eyelet		22 per eyelet	A (silk)	A (silk)
77	<u>Sew hook and eye to collar.</u> Finished appearance. The hook and eye shall be positioned to properly engage each other, effecting a flat, smooth closure at the front of the collar without misalignment. a. Position and securely sew the hook to the right end and the eye to the left end of the collar. The hook and eye shall be positioned with their front edges even with the respective front ends of the collar and securely sewn to the collar at the top and bottom edge of the hook and eye. The stitching on each side shall not be more than 3/8 inch from the front end of the collar through the individual holes at the rear of the hook and eye.	Hand		12 per hook and 12 per eye	C (silk) (double thread)	
78	<u>Finish collar.</u> a. Securely tack the lower corners of the collar to the coat.	Hand		8-10	C	

MLL-DTL-82156D(MC)

TABLE I. Manufacturing requirements - Continued.

NO	OPERATION	STCH TYPE	SEAM/ STCH TYPE	STCH/IN	NDL	BOB/ LPR
78	<u>Finish collar.</u> (cont'd)					
	b. Turn under the end and top edge of the lining at the right end of the collar. Position the folded edge of the lining under the hook and fell it to the end of the collar. Continue felling along the top folded edge to the end of the stitching joining the lining to the collar.	Hand		8-10	C (silk)	
	c. Turn under and fell the lower edge of the collar lining to the coat from end to end, catching the turned under portion of the lining at the right end in the felling.	Hand		8-10	C (silk)	
	NOTE: The lower edge of the collar lining may be basted to the coat prior to felling.					
	d. Fell the collar extension tab to the left end of the collar and continue along the folded top edge to the end of this stitching joining the lining to the collar.	Hand		8-10	C (silk)	
	e. Turn the collar eyelet covers to the inside of the collar and fell the front edge, from top to bottom edge. Continue the felling along the bottom edge for a distance of 1/2 inch from the front edge.	Hand		8-10	C (silk)	
79	<u>Fell front eyelet cover.</u>					
	a. Turn the front eyelet cover to inside. Securely fell the upper and lower seamed edges of the cover to the facing, placing stitching over the folded edges of the cover.	Hand		6-8	C (silk)	
80	<u>Mark for buttons on right front.</u>					
	a. Mark the location for sewing seven 40-line insignia buttons to the right front of the coat to properly engage with the buttonhole of the left front. The mark for top button shall be in line with right front end of collar and remaining buttons shall be in vertical alignment with top mark.					

MIL-DTL-82156D(MC)

TABLE I. Manufacturing requirements - Continued.

NO	OPERATION	STCH TYPE	SEAM/ STCH TYPE	STCH/IN	NDL	BOB/ LPR
81	<p><u>Sew on buttons.</u></p> <p>a. Sew on 40-line insignia button at each of the marks on the right front through all plies.</p> <p>b. The insignia buttons on the front shall be sewn with the head of the eagle upright.</p>	Hand		8 per button (double thread)	24/4	
82	<p><u>Clean coat.</u></p> <p>a. Pull any basting thread and trim and remove any loose ends of thread. Remove any spots, stains and tickets without injury to the material.</p>					
83	<p><u>Press coat.</u></p> <p>a. The coat shall be well pressed throughout with a heated pressing iron or pressing machine of a type suitable to obtain the desired shape and appearance in accordance with good manufacturing practices.</p> <p>b. Press the fronts smooth and flat, straightening and shaping the front edges and working fullness towards the chest. Care shall be exercised in pressing the fronts so that the bottom edges are even.</p> <p>c. Press the entire collar smooth and flat.</p> <p>d. Press the fronts on a body machine, shrinking and properly shaping the chest.</p> <p>e. Press the sides, working the fullness towards the back.</p> <p>f. Press the back smooth and flat, removing all fullness.</p> <p>g. Press the sleeves smooth and flat, creasing at the backarm and forearm seam. The backarm crease shall be on the backarm seam. The forearm and backarm crease shall extend uniformly to a point approximately 3 to 3-1/2 inches below the base of the armhole.</p>					

MIL-DTL-82156D(MC)

TABLE I. Manufacturing requirements - Continued.

NO	OPERATION	STCH TYPE	SEAM/ STCH TYPE	STCH/IN	NDL	BOB/ LPR
83	<p><u>Press coat.</u> (cont'd)</p> <p>h. Block the shoulders to remove the fullness and press shoulders smooth on a shoulder shaping machine. Press the shoulder strap flat.</p> <p>i. Press the armholes solid from the inside, creasing the armhole at the front, and creasing the excess material at the armpit. The armpit and back of the armhole shall be held short while pressing.</p> <p>j. Block the armholes on a pressing buck, shrinking the top sleeves.</p> <p>k. Press the lower edge of the coat smooth, flat, and even.</p> <p>l. Remove all wrinkles and impressions from under shoulder straps.</p> <p>m. Press body lining throughout, removing all back wrinkles and creases. Press the front and back lining pleats smooth and flat.</p> <p>n. Remove all gloss marks.</p> <p>o. Remove any wrinkles and creases missed by previous pressing operations.</p>					
84	<p><u>Mark for belt loop button.</u></p> <p>a. Mark each side seam for the location of one removable 27-line insignia button to properly align with the eyelet buttonhole in the belt loop.</p>					
85	<p><u>Cut opening for belt loop buttons.</u></p> <p>a. Cut a vertical opening, approximately 1/4 inch long, at the mark on each side seam. The opening shall be made through the side seam of the wool parts of the coat only.</p> <p>b. Securely tack or bartack each end of the opening.</p>	Hand or 301		2-4 4-6	C (silk) A (silk)	A (silk)

MIL-DTL-82156D(MC)

TABLE I. Manufacturing requirements - Continued.

NO	OPERATION	STCH TYPE	SEAM/ STCH TYPE	STCH/IN	NDL	BOB/ LPR
86	<p><u>Attach buttons.</u></p> <p>a. Sew one 40-line insignia button at each of the marks on the right front. The buttons shall be sewn through all plies of materials.</p> <p>b. Inset the shank on one 27-line insignia button through each eyelet on shoulders, ornamental sleeve patch, and through the openings at the side seams.</p> <p>c. Attach a reinforcement disc (see 3.3.5) over the shank of the button on each side seam. Secure buttons to shoulders, side seam and ornamental sleeve patch with metal ring toggles.</p> <p>d. Button belt loops.</p>					

3.7. Finished measurements. The finished measurements shall conform to those listed in Table II.

Table II. Finished measurements. 1/

Size (inches)	Breast 2/ (inches)	Back length 3/ (inches)	Sleeve length 4/ (inches)
Short			
34	35	28-3/4	17-1/2
35	36	28-7/8	17-1/2
36	37	29	17-1/2
37	38	29-1/8	17-1/2
38	39	29-1/4	17-1/2
39	40	29-3/8	17-1/2
40	41	29-1/2	17-1/2
41	42	29-5/8	17-1/2
42	43	29-3/4	17-1/2
44	45	30	17-1/2
46	47	30-1/4	17-1/2

MIL-DTL-82156D(MC)

Table II. Finished measurements - Continued. 1/

Size (inches)	Breast <u>2/</u> (inches)	Back length <u>3/</u> (inches)	Sleeve length <u>4/</u> (inches)
Regular			
34	35	29-3/4	18-1/2
35	36	29-7/8	18-1/2
36	37	30	18-1/2
37	38	30-1/8	18-1/2
38	39	30-1/4	18-1/2
39	40	30-3/8	18-1/2
40	41	30-1/2	18-1/2
41	42	30-5/8	18-1/2
42	43	30-3/4	18-1/2
44	45	31	18-1/2
46	47	31-1/4	18-1/2
Long			
34	35	30-3/4	19-1/2
35	36	30-7/8	19-1/2
36	37	31	19-1/2
37	38	31-1/8	19-1/2
38	39	31-1/4	19-1/2
39	40	31-3/8	19-1/2
40	41	31-1/2	19-1/2
41	42	31-5/8	19-1/2
42	43	31-3/4	19-1/2
44	45	32	19-1/2
46	47	32-1/4	19-1/2
Extra Long			
34	35	32-1/4	20-1/2
35	36	32-3/8	20-1/2
36	37	32-1/2	20-1/2
37	38	32-5/8	20-1/2
38	39	32-3/4	20-1/2
39	40	32-7/8	20-1/2
40	41	33	20-1/2
41	42	33-1/8	20-1/2
42	43	33-1/4	20-1/2
44	45	33-1/2	20-1/2
46	47	33-3/4	20-1/2

1/ Tolerance for all measurements shall be $\pm 3/8$ inch.

MIL-DTL-82156D(MC)

- 2/ Breast measurement shall be taken with coat buttoned, from folded edge to folded edge in line with the pit of the armhole; multiply by 2.
- 3/ Back length measurement shall be taken along the center back seam, from the lower edge of the collar to the piped bottom edge of the coat.
- 4/ Sleeve length measurement shall be taken along the forearm seam from the pit of the armhole to the bottom edge of the sleeve.

3.8. Workmanship. The finished coats shall conform to the quality and grade of product established by this specification.

3.9. Recycled, recovered, or environmentally preferable materials. Recycled, recovered, or environmentally preferable materials should be used to the maximum extent possible provided that the material meets or exceeds the operational and maintenance requirements, and promotes economically advantageous life cycle costs.

4. VERIFICATION

4.1. Classification of inspection. The inspection requirements specified herein are classified as follows:

- a. First article inspection (see 4.3).
- b. Conformance inspection (see 4.4).

4.2. Inspection conditions. Unless otherwise specified, all inspections shall be performed in accordance with the test conditions specified in Table III.

MIL-DTL-82156D(MC)

Table III. Test methods.

Components	Characteristics	Reqmt. para.	Test method	No. det. per S/unit	Results reported as
Hook and eye	Tackiness	3.3.17	4.5.2	1	Pass or fail
Padding felt (for collar)	Material identification	3.3.6	1200	1	Pass or fail
	Weight, oz per sq yd	3.3.6	5041	5	Avg. of the 5 det. to nearest 0.1 oz.
	Color	3.3.6	Visual	1	Pass or fail

4.3. First article inspection. When a first article is required (see 6.2), it shall be examined for the defects specified in 4.4.2.1 and 4.4.2.2.

4.4. Conformance inspection.

4.4.1 Component and material testing. Components and materials shall be tested in accordance with all the requirements of reference specifications, figures, and standard unless otherwise excluded, amended, modified or qualified in this specification or applicable purchase document. In addition to the testing provisions contained in subsidiary specifications, figures, and standards, testing shall be performed on the components listed in Table III for the characteristics noted. Wherever applicable, tests shall be conducted in accordance with ASTM E1282 and FED-STD-191. When the "Results reports as" columns are not indicated, they shall be reported as required by the referenced test method. All test reports contain individual values utilized in expressing the final results.

4.4.1.1. Sampling for testing. Unless otherwise specified in subsidiary specifications, sampling shall be in accordance with ANSI/ASQC Z1.4. The unit for expressing lot sizes and sample unit fore testing each component shall be in accordance with applicable subsidiary specifications and as follows:

<u>Component</u>	<u>Expressed as</u>	<u>Sample unit for testing</u>
Hook and eye	100 each	two each, hook and eye
Padding for collar	yards	1/4 yard full width

4.4.1.2. In-process inspection. An inspection shall be performed during manufacture of the end item to ascertain that the

MIL-DTL-82156D(MC)

operations are performed as specified herein. The Government reserves the right to determine the acceptability of construction methods not performed in accordance with the specified requirements for operations or subassemblies.

4.4.2 Examination of end item. The defects found during examination of the end item shall be classified in accordance with 4.4.2.2 through 4.4.2.5. The sample unit shall be one coat.

4.4.2.1. Classification of defects. All defects shall be classified as indicated, except those numbered 1 through 23 in the major classification column, which shall be classified as follows:

Major defect - When seriously affecting appearance or serviceability.

Minor A defect - When not seriously affecting appearance or serviceability.

4.4.2.2. General defects. General defects shall be classified as indicated below.

Examine	Defects	Classification		
		Major	Minor A	B
Buttonholes (construction)	a. One or more omitted or added.	101		
	b. Wrong type or uncut.		201	
	c. Not corresponding to size of button:			
	- too small, not permitting button to enter buttonhole.	102		
	- too large, 3/8 inch or more longer than the diameter of button (measured at inside of purling).		202	
d. Buttonhole not securely caught on fabric, causing stitching to pull away from fabric.	103			
e. Bartack missing or loose on:				
- one buttonhole.			203	
- two or more buttonholes.	104			

MIL-DTL-82156D(MC)

Examine	Defects	Classification		
		Major	Minor A B	
Buttonholes (construction) (cont'd)	f. Bartack misplaced not serving intended purpose on: - one buttonhole. - two or more buttonholes.		204 301	
	g. One or more broken stitches in: - one buttonhole. - two or more buttonholes.	105	205	
	h. More than two skipped stitches in: - one buttonhole. - two or more buttonholes.		206 302	
	i. Ragged edges, affecting appearance.		303	
	j. Gimp omitted in one or more buttonholes.		207	
	k. Stitches per buttonhole (not including bartack) less than the minimum specified: - one or two stitches. - three or more stitches.		208 304	
	l. One or more buttonholes finished with purling on the underside.	106		
	m. Ends of gimp not pulled through the underside on one or more buttonholes.		305	
	Buttons or ring toggles	a. Missing, loose, broken, or defective: - one button or ring toggle. - two or more buttons or two or more ring toggles.	107	209
		b. Not specified type, size, color or finish.		210
c. One or more buttons right front sewn with the head of the eagle in other than upright position.			306	

MIL-DTL-82156D(MC)

Examine	Defects	Classification	
		Major	Minor A B
NOTE: Buttons shall be considered defective if they have sharp, rough, cracked, or split edges; unsound soldering, scratches; dents, blemishes or imbedded foreign matter on face side of button; loose shanks; or are badly shaded.			
Cleanness	a. One or more removable spots or stains clearly noticeable outside of the coat.		211
	b. One or more removable spots clearly noticeable on the inside of the coat.		307
	c. One or more spots or stains of an obvious permanent nature.	1	
	d. Thread ends not trimmed, loose thread ends, two or more shade markings, or bastings not removed throughout garment (to be scored when the condition exists on major portion of coat).		212
Components and assembly	a. Any defective component or defect of assembly (not herein classified).	2	
	b. Any component part or required operation omitted (not herein classified).	3	
Cutting	a. Any component part of basic wool material not cut in accordance with directional lines on patterns or in accordance with the specification requirements.	108	
	b. Piping or binding material cut on bias		213
	c. Any lining part not cut in accordance with directional lines on patterns.		214
Eyelet (construction)	a. One or more omitted or added.	109	
	b. Wrong type.		215

MIL-DTL-82156D(MC)

Examine	Defects	Classification	
		Major	Minor A B
	c. Eyelet not securely caught on fabric, causing stitching to pull away from fabric.	110	
	d. Diameter of inside opening less than 1/8 inch or more than 1/4 inch.		308
	e. One or more eyelets uncut.		216
	f. One or more broken stitches in: - one eyelet. - two or more eyelets.		309
	g. More than two skipped stitches in one or more eyelets.		310
	h. One or more eyelets finished with the purling on the underside.		218
Metal eyelet (collar)	a. Any omitted.		219
	b. Defective eyelet.		220
	c. Not specified type or size.		221
Hook and eye	a. Not specified type or size.		222
	b. Not aligned, causing collar ends to be uneven by 1/4 inch or more when front is buttoned and hook and eye are fastened.		223
	c. Hook and eye not securely tacked to ends of collar.		224
	d. Hook and eye misplaced, i.e., hook positioned on left end, eye positioned on right end of the collar.		225
Material defects and damages	a. Any weakening defects, such as smash, multiple float, and loose slub, etc., that may develop into a hole.	4	
	b. Any hole (including drill holes).	5	

MIL-DTL-82156D (MC)

Examine	Defects	Classification	
		Major	Minor A B
	c. Shade bar, unsightly slub, etc.:		
	- on outside.	6	
	- on inside.		226
	d. Needle chews which may develop into a hole.	7	
	e. Scissors or knife cut, tear, mend, or burn.	8	

NOTE: Material defects and workmanship damages are to be classified as indicated above only when the condition is one which definitely weakens the fabric or when it is so conspicuously located as to be clearly noticeable. Weakening or nonweakening conditions which are inconspicuous and have negligible effect on serviceability are to be classified as follows:

Material defect - No defect
Workmanship damages - Minor B defect

Pressing	a. Burned or scorched.	9	
	b. Pressing omitted (entire garment).		227
	c. Poorly pressed (unless otherwise indicated).		228
	d. Armhole stretched, affecting appearance.		229
	e. Basting or pressing impressions not removed on major portion of the coat.		311
	f. Gloss not removed throughout coat, affecting appearance.		312
	g. Armholes not blocked or blocked poorly.		230
	h. Inside of armholes not pressed solid.		231
	i. Edges bulky, i.e., not pressed solid, affecting appearance.		313
Pressing (cont'd)			

MIL-DTL-82156D(MC)

Examine	Defects	Classification	
		Major	Minor A B
Seams and stitching	j. Sleeve not creased as required on forearm and backarm seam.		314
	k. Armhole sleeve seam not pressed open from backarm seam of sleeve and across top as specified.		232
	l. Linings not pressed smooth.		315
	a. Accuracy of seaming:		
	1. Any seam twisted, puckered or pleated, affecting appearance.		233
	2. Part of garment caught in any unrelated operation or stitching.	10	
	3. Unsightly hand felling or blind stitching exposed on outside of coat, affecting appearance.		234
	4. Ends of all stitching (when not caught in other seams or stitching) not backtacked or backstitched as required.		316
	5. Wrong color of thread or two shades of thread used on outside of coat, affecting appearance.	11	
	b. Gage of stitching (edge or raised stitching):		
1. Irregular, i.e., unevenly gaged; or various stitching not uniform, affecting appearance.		235	
2. Beyond range of width specified; or varies more than 1/16 inch when no range is specified.		317	
Seams and stitching (cont'd)			

MIL-DTL-82156D(MC)

Examine	Defects	Classification	
		Major	Minor A B
	c. Open seams: 1. On outside: - up to 1/4 inch inclusive. - more than 1/4 inch but not more than 1/2 inch. - more than 1/2 inch. 2. On inside: - more than 1/2 inch (except machine felling). - up to 1/2 inch inclusive (except machine felling). - up to 1 inch inclusive (machine felling). - more than 1 inch (machine felling).	111	318 236 237 319 320 238
	d. Raw edges: 1. On outside: - up to 1/8 inch inclusive. - more than 1/8 inch but not more than 1/4 inch. - more than 1/4 inch. 2. On inside: - more than 1/8 inch but not more than 1/4 inch. - more than 1/4 inch.	112	321 239 322 240
	e. Runoffs (see classification of open seams). f. Stitch tension: 1. Loose tension resulting in loose seam.	113	
Seams and stitching (cont'd)			

NOTE: One or more broken stitches or two or more continuous skipped or runoff stitches constitute an open seam.

NOTE: Raw edges shall be classified as such when they occur at places where an edge is required to be turned under. Raw edges not caught in stitching shall be classified as open seams.

MIL-DTL-82156D(MC)

4.4.2.3. Detailed defects (outside of coat). Detailed defects on outside of coat with coat buttoned on form shall be classified as follows:

Examine	Defects	Classification	
		Major	Minor A B
Collar (construction and setting)	a. Interlining omitted.	116	
	b. Interlining tight or twisted, causing puckers on collar, affecting appearance.		246
	c. Tight at joining to front or back, causing puckers or pleats at neck of coat, affecting appearance.	13	
	d. Piping irregular, affecting appearance.		247
	e. Collar ends overlapping when fastened.		248
	f. Collar ends spread open more than 3/8 inch when fastened.		249
	g. One ply of outer basic material.	117	
	h. Binding strip at top or bottom edge of interlining omitted.		250
	i. Binding strip at top or bottom edge of interlining other than material specified.		251
	j. Center of eyelets from finished ends of collar less than 1-1/4 inches or more than 1-3/4 inches.		252
	k. One or both eyelets off-center with top and bottom edges of collar by more than 1/4 inch.		253
l. Collar off-center by more than 3/8 inch.		326	

MIL-DTL-82156D(MC)

Examine	Defects	Classification	
		Major	Minor A B
Collar (construction and setting) (cont'd)	m. Binding strip at top edge of interlining positioned more than 1/8 inch beyond top edge of piping on outer ply of collar.		254
	n. Binding strip at top edge of interlining irregular in width, affecting appearance; or not exposed beyond top edge on outer ply of collar.		255
	o. Collar irregular in width by 1/4 inch or more.	118	
	p. Front finished ends of collar uneven in width by 3/16 inch or more.	119	
Alignment of front buttons and buttonholes	a. Not aligned, causing a noticeable bulge or twist on fronts when buttoned, affecting appearance.		256
Length of fronts	a. Left front at corner shorter than right front at bottom by: - more than 1/8 inch but not more than 1/4 inch. - more than 1/4 inch.		257
	b. Left front at corner longer than right front by: - more than 1/4 inch but not more than 3/8 inch. - more than 3/8 inch.	120	
	c. Right front at corner exposed beyond edge of left front by more than 1/8 inch.		258
			259
Shoulder (construction)	a. Improperly joined or set, causing shoulder or back to twist.	14	
Shoulder pads	a. Not completely caught in armhole tacking.		260

327

MIL-DTL-82156D(MC)

Examine	Defects	Classification	
		Major	Minor A B
Shoulder pads (cont'd)	b. Misplaced not serving the intended purpose; i.e., too far back or too far forward.		261
	c. One or both pads omitted.		262
Shoulder straps (construction and setting)	a. Misplaced; i.e., one strap further forward or back from position of other strap, affecting appearance.		263
	b. Misplaced; so that it will not lie flat when buttoned, causing bulge or twist on strap.	15	
	c. Poorly shaped.		328
	d. Shoulder seam exposed beyond back edge of shoulder strap (except rounded end).		264
	e. Width of shoulder strap at armhole seam (including piping) less than 2-1/8 inches or more than 2-5/8 inches.		265
	f. Width of shoulder strap across center of buttonhole eyelet (including piping) less than 1-1/2 inches or more than 2 inches.		266
	g. Rounded end of shoulder strap positioned less than 1/4 inch or more than 3/8 inch from collar edge.		329
	h. Piping irregular in width, affecting appearance.		267
	i. Upper side of strap full or twisted, affecting appearance.		330
	j. Back edge of strap less than 1/4 inch or more than 1/2 inch from shoulder seam at armhole.		331

MIL-DTL-82156D(MC)

Examine	Defects	Classification	
		Major	Minor A B
Shoulder strap buttonhole and button	a. Button not aligned with buttonhole, causing a bulge or twist on strap or puckers on shoulders, affecting appearance.		268
	b. Buttons not uniformly set by more than 1/4 inch.		269
	c. Buttonhole 1/4 inch or more off center.		270
	d. Buttonhole from outer edge of piping at the collar end of the strap: - less than 5/8 inch but not less than 1/2 inch, or more than 3/4 inch. - less than 1/2 inch.		332
Armholes (construction)	a. Badly stretched, affecting appearance.	16	
	b. Taped too tight, causing puckering around armhole seam, affecting appearance.	17	
	c. Crooked seam, affecting appearance.		272
	d. Tape stitching exposed and visible to outside surface.		333
Sleeves	e. Sleeve-head pads not completely tacked to armholes; or misplaced, not serving intended purpose.		273
	f. One or both sleeve-head pads omitted.		274
	a. Setting and hang: 1. Sleeve fullness misplaced, affecting appearance.		275

MIL-DTL-82156D(MC)

Examine	Defects	Classification	
		Major	Minor A B
Sleeves (cont'd)	2. Backarm seam of sleeve not matching side back seam by: - more than 1/4 inch but not more than 1/2 inch. - more than 1/2 inch.	121	276
	3. Hang of sleeves on the same coat in opposite direction by more than 2 inches.		277
	4. Sleeve tight in armhole; i.e., roll effect not present.		278
	b. Sleeve lining:	18	
	1. Twisted, tight, or short, causing bulge, twist, or puckering on outside of sleeve.		
	2. Sleeve lining too long, causing lining to sag at bottom more than 1/2 inch.		334
	3. Sleeve lining seams out of alignment more than 3/4 inch with sleeve seams at armhole or at bottom of sleeve.		335
	4. Cut dart on lining under sleeve omitted.		336
	5. One or both lining darts not pressed flat.		337
	c. Construction of sleeves:		
	1. Wigan twisted, tight or pleated, causing ridges or puckering on outside of bottom of sleeves, affecting appearance.		279
	2. Tacking on bottom turnup to wigan omitted or insecure.	280	
	3. Sleeve bottom edge uneven by more than 1/4 inch.	338	
	4. Tacking on one or both sleeve lining seams to sleeve seams omitted, or insecure.	339	

MIL-DTL-82156D(MC)

Examine	Defects	Classification	
		Major	Minor A B
Sleeves (cont'd)	5. Bottom edge of sleeve lining turnup less than 1 inch or more than 1-1/2 inches up from bottom edge of sleeve.		340
	6. Cut dart on wool under sleeve omitted.		281
	7. One or both wool sleeve darts not pressed open, smooth and flat.		341
	d. Ornamental sleeve pieces:		
	1. Piping irregular, affecting appearance.		282
	2. Ornamental piece stitched to sleeve too full or twisted, affecting appearance.		283
	3. Length of ornamental piece (including piping) less than 5-5/8 inches or more than 6-3/8 inches.		284
	4. Width at top and bottom points (including piping) less than 2-1/8 inches or more than 2-7/8 inches.		285
	5. Width at center point (including piping) less than 2-3/8 inches or more than 3-1/8 inches.		286
	6. Poorly shaped, affecting appearance.		287
7. Set on crookedly, affecting appearance.		288	
8. Misplaced; i.e., one piece further forward or back from position of other piece, affecting appearance.		289	
9. Bottom edge not horizontal with bottom edge of sleeve by more than 1/8 inch.		290	

MIL-DTL-82156D(MC)

Examine	Defects	Classification	
		Major	Minor A B
Sleeves (cont'd)	<p>10. Ornamental piece stitched to sleeve with pointed ends toward forearm seam of sleeve.</p> <p>e. Position of buttons on ornamental pieces (measurements made from center of button):</p> <p>1. Front top and bottom edges (including piped edges):</p> <ul style="list-style-type: none"> - less than 3/4 inch but not less than 1/2 inch. 342 - more than 1 inch but not more than 1-1/4 inches. 343 - less than 1/2 inch or more than 1-1/4 inches. 291 <p>2. Top or bottom button from scalloped edge (including piped edge):</p> <ul style="list-style-type: none"> - less than 5/8 inch but not less than 3/8 inch. 344 - more than 7/8 inch but not more than 1-1/8 inches 345 - less than 3/8 inch or more than 1-1/8 inches. 292 <p>3. Center button from pointed edge (including piped edge):</p> <ul style="list-style-type: none"> - less than 7/8 inch but not less than 5/8 inch. 346 - more than 1-1/8 inches but not more than 1-3/8 inches. 347 - less than 5/8 inch or more than 1-3/8 inches. 293 <p>4. Center button not in line with pointed edge by more than 1/4 inch. 294</p>	122	
Body (outside)	a. Fitting of body linings tight, short, or twisted, causing fullness or twist on outside of coat, affecting appearance.	19	

MIL-DTL-82156D(MC)

Examine	Defects	Classification	
		Major	Minor A B
Body (outside) (cont'd)	b. Fitting of front interlining:		
	1. Tight, short, or twisted, causing fullness or twist on outside of coat, affecting appearance.	20	
	2. Too full, causing coat front to have a wavy appearance.	21	
Chest darts	a. One or both omitted.	123	
	b. End of one or both darts not properly tapered, causing bulge of fullness, affecting appearance.		295
	c. Equal length of darts not uniform by 1/4 inch or more.		348
	d. Cut edges of dart not turned towards armhole.		349
	e. Not pressed smooth and flat.		296
Waist darts	a. One or both omitted.	124	
	b. Top or lower end of one or both darts not properly tapered, causing bulge or fullness, affecting appearance.		297
	c. Equal length of darts not uniform in length by 1/4 inch or more.		350
	d. Alignment of both waist darts:		351
	- top or bottom end out of horizontal alignment by 1/4 inch or more.		
	e. Folded edge not pressed toward side seam.		352
	f. Not pressed smooth and flat.		298
g. Top or lower end of one or both darts not securely backstitched.		299	

MIL-DTL-82156D(MC)

Examine	Defects	Classification	
		Major	Minor A B
Front and bottom edges	a. Front edges stretched, affecting appearance.		201a
	b. Piping set on tight, causing puckering on front, affecting appearance.		202a
	c. Front or bottom piping irregular, affecting appearance.		203a
	d. Bottom edge stretching, puckered, or uneven, affecting appearance.		353
	e. Bottom corner or left front poorly shaped, affecting appearance.		204a
	f. Left front rolling outward below bottom button.	22	
	g. Front edge irregular, affecting appearance.		205a
	h. Piping tight on front or bottom edge, causing puckering outside of coat, affecting appearance.		206a
	i. Left front not dressed as specified.		207a
	Front facings	a. Short, tight or twisted, causing fullness or twists on fronts, affecting appearance.	23
Back side panel seams	a. Curved panel seam on back of coat stretched or distorted, affecting appearance.		208a
Belt loops (construction and position)	a. Poorly shaped or not of uniform shape, affecting appearance.		209a
	b. Bottom end of one or both loops out of horizontal alignment with bottom front buttonhole by: - more than 3/4 inch below or more than 3/8 inch above.		210a

MIL-DTL-82156D(MC)

Examine	Defects	Classification		
		Major	Minor A B	
Belt loops (construction and position) (cont'd)	c. Pointed end of one or both loops not toward top of coat.		211a	
	d. One or both not stitched on the side seam.		212a	
	e. One or both not vertically straight; i.e., set on an angle, affecting appearance.		213a	
	f. Alignment of both loops: - top or bottom end out of horizontal alignment by more than 1/4 inch.		214a	
	g. One or more edges not properly forced out; i.e., having a fold or lip of 1/8 inch or more.		354	
	h. Bottom of loop not centered on side seam by more than 1/4 inch.		215a	
	Belt loop buttonhole and button (position and buttonhole attachment)	a. Button not aligned with buttonhole, causing a bulge or twist on loop or puckers on coat, affecting appearance.		216a
		b. Buttons not uniformly set by more than 1/4 inch.		355
		c. Buttonhole 1/4 inch or more off center.		217a
		d. Buttonhole less than 1/2 inch or more than 3/4 inch from pointed end of loop.		356
e. Reinforcement disc beneath one or both buttons omitted.			357	
Openings cut for belt loop buttons	a. One or both omitted.	125		
	b. Opening not constructed vertically.		218a	
	c. One or more ends on one or both openings not securely tacked.		219a	

MIL-DTL-82156D(MC)

Examine	Defects	Classification	
		Major	Minor A B
Openings cut for belt loop buttons (cont'd)	d. Opening constructed through body lining.	126	
	e. Misplaced; i.e., more than 1/4 inch from marks indicated by patterns, or not positioned on side seam.		220a
Front buttonholes (position)	a. Position from front edge (including piped edge) less than 3/8 inch or more than 7/8 inch.		221a
	b. More than 1/4 from equal spacing.		222a
	c. Top or bottom buttonhole positioned more than 1/2 inch from pattern marks.		223a
	d. Unevenly spaced from front edge by more than 3/16 inch.		224a
Front eyelets (position)	a. Center of top eyelet not in vertical alignment with right end of collar by 1/4 inch or more.		225a
	b. Lower eyelets not in vertical alignment with top eyelet by 1/4 inch or more.		226a
	c. More than 1/4 inch from equal spacing.		227a
Front buttons (position)	a. Out of vertical alignment by 1/4 inch or more.		228a

MIL-DTL-82156D(MC)

4.4.2.4. Detailed defects (inside of coat). Detailed defects on inside of coat shall be classified as follows:

Examine	Defects	Classification	
		Major	Minor A B
Right front eyelet cover	a. Front raw edges not stitched together prior to seaming to right facing.	127	229a
	b. Upper or lower seamed edge not hand felled to facing.		230a
	c. Upper or lower seam edge not securely hand stitched to facing.		358
	d. Omitted.		
	e. Front corner of eyelet cover exposed beyond upper edge of right front.		359
	f. Front edge of cover positioned less than 1/4 inch or more than 3/4 inch in from front edge of right front.		231a
Labels	a. Any required label missing, incorrect, or illegible; or size label not securely caught in stitching.	128	
	b. Identification label not stitched on all four sides.		232a
	c. Bottom edge of identification label less than 3 inches or more than 5 inches from bottom finished edge of coat.		360
	d. Identification label not stitched to outside of right facing.		361
Hanger	a. Hanger omitted or ends not securely stitched.	129	
	b. Less than 1-7/8 inches or more than 2-1/8 inches long measured along the lower edge of the collar lining.		233a

MIL-DTL-82156D(MC)

Examine	Defects	Classification		
		Major	Minor A B	
Hanger (cont'd)	c. Hanger not stitched to neck of coat prior to seaming collar to neck of coat.		234a	
	d. Finished width less than 1/4 inch or more than 3/8 inch wide.			362
Front facings	a. Fullness or pleats on facings between eyelets; buttonholes; or between front edge and eyelet or buttonholes.		235a	
	b. Tacking on back edge to one or both interlinings: - omitted. - insecure or incomplete for a distance of more than 4-1/2 inches below shoulder seams, or more than four inches above bottom edge of coat.		236a	363
	c. Felling at bottom or back edge of front facings omitted or insecure on one or both facings.		237a	
	d. Felling along folded edge of one or both facings at collar notch omitted or insecure.		238a	
Body linings	a. Excessive puckering or pleated.			364
	b. Twisted, not affecting smoothness on outside of coat.			365
	c. One or both chest pleats on shoulder omitted.		239a	
	d. Folded edge of one or both chest pleats facing front edge of coat.			366
	e. Pleat omitted at center of back lining.		240a	
	f. Pleat less than 1/2 inch in depth at center of back lining.			367
	g. Bottom hem less than 5/8 inch or more than 7/8 inch wide.			368

MIL-DTL-82156D(MC)

Examine	Defects	Classification	
		Major	Minor A B
Body linings (cont'd)	h. Lining too long; i.e., exposed beyond bottom edge of coat.		241a
	i. Facing-lining seam, side seams, and side back seams not towards back or not pressed smooth and flat.		242a
	j. Waist darts not towards the side seams or not pressed smooth and flat.		243a
Lining - securing straps	a. One or both omitted or insecure.		244a
	b. Less than 1/4 inch or more than 3/8 inch wide.		369
	c. One or both positioned more than 1 inch from side seam.		370
	d. End of one or both straps not finished between the piping at the bottom edge of the coat and the side seam allowance.		371
	e. One or both not folded and stitched across width.		372
	f. One or both not properly attached to the lining hem or coat; causing twist or distortion to either the lining or the coat.		245a
	g. One or both exposed beyond bottom edge of the coat.		246a
Serge or overedge stitching	a. Omitted where specified on one or more raw edges for seams joining fronts and back.		247a
Serge or overedge stitching (lining joined seams)	a. Omitted where specified on one or more seams.		248a
Underarm shields	a. One or both omitted.		249a
	b. Not two-piece lining construction.		250a

MIL-DTL-82156D(MC)

Examine	Defects	Classification	
		Major	Minor A B
Inside of armhole	c. Tacking on one or both shields, along side or bottom edge to body lining, omitted or insecure.		373
	d. Top edge not caught in armhole tacking or stitching when tacked by hand.		374
	e. Puckered, pleated, or twisted.		375
	f. One or both shields misplaced, not serving intended purpose.		376
	a. Backstitching at armpit of armhole, from backarm seam of sleeve to front edge of shield omitted.		377
	Collar lining extension piece	a. Omitted.	130
b. Extended less than 1/2 inch or more than 1 inch beyond left end of collar.			378
c. Felling omitted or insecure at end or top edges.			251a
d. Stitching at top, front and bottom edges, or across width of collar tab (forming box stitch) omitted.			252a
Collar lining and eyelet covers	a. Ends of collar lining not securely tacked.		253a
	b. One or both eyelet covers omitted.		254a
	c. One or both eyelet covers not covering eyelet.		255a
	d. Width of collar eyelet less than 1-5/8 inches or more than 1-7/8 inches.		379

MIL-DTL-82156D(MC)

Examine	Defects	Classification	
		Major	Minor A B
Collar lining and eyelet covers (cont'd)	e. Felling on front edge and along lower corner of one or both eyelet covers omitted. f. Felling along lower corners of one or both eyelet covers extending for a distance of more than 3/4 inch.		256a 380

4.4.2.5. Finished measurements. Any measurement deviating from the nominal dimensions and tolerance specified in Table II shall be classified as a size measurement defect. Sleeve lengths uneven by more than 1/2 inch shall be scored as a size measurement defect.

4.5. Tests.

4.5.1 Metal composition. Chemical composition shall be determined in accordance with ASTM E1282.

4.5.2 Test for tackiness. At room temperature (60°F to 80°F), press a piece of tissue paper against the lacquered surface for 30 seconds, using any pressure capable of being exerted by the thumb and two fingers. The tissue shall not adhere to the lacquered surface, but shall fall free when pressure is released.

5. PACKAGING

5.1. Packaging. For acquisition purposes, the packaging requirements shall be as specified in the contract or order (see 6.2). When actual packaging of material is to be performed by Department of Defense (DoD) personnel, these personnel need to contact the responsible packaging activity to ascertain requisite packaging requirements. Packaging requirements are maintained by the Inventory Control Point's packaging activity within the Military Department of Defense Agency, or within the Military Department's Systems Command. Packaging data retrieval is available from the managing Military Department's or Defense Agency's automated packaging files, CD-ROM products, or by contacting the responsible packaging activity.

MIL-DTL-82156D(MC)

6. NOTES

(This section contains information of a general or explanatory nature that may be helpful, but is not mandatory.)

6.1. Intended use. The coat described herein is intended for wear by enlisted male personnel of the U.S. Marine Corps Drum and Bugle Corps (Drum Major).

6.2. Acquisition requirements. Acquisition documents must specify the following:

- a. Title, number, and date of the specification.
- b. Issue of DoDISS to be cited in the solicitation, and if required, the specific issue of individual documents referenced (see 2.2).
- c. Packaging requirements (see 5.1).
- d. Whether first article is required (see 3.2).
- e. Number of coats in first article (see 3.2).

6.3. Standard sample. For information regarding the availability of standard sample costs and standard shades specified, address inquiry to the procuring activity issuing the invitation for bids.

6.4. Figures. Figures 1 through 6 are furnished for information purposes only. To the extent of any inconsistencies between the written specification and the figures, the written specification will govern.

6.5. Vinyl piping. Thielex Plastics Company has manufactured vinyl piping meeting the requirements of 3.3.11.1.

6.6. Subject term (keyword) listing.

Dress
Enlisted
Music

MIL-DTL-82156D(MC)

6.7. Changes from previous issue. Marginal notations are not used in this revision to identify changes with respect to the previous issue due to the extent of the changes.

Preparing Activity:

Navy - MC

Project No. 8405-N326

MIL-DTL-82156D (MC)

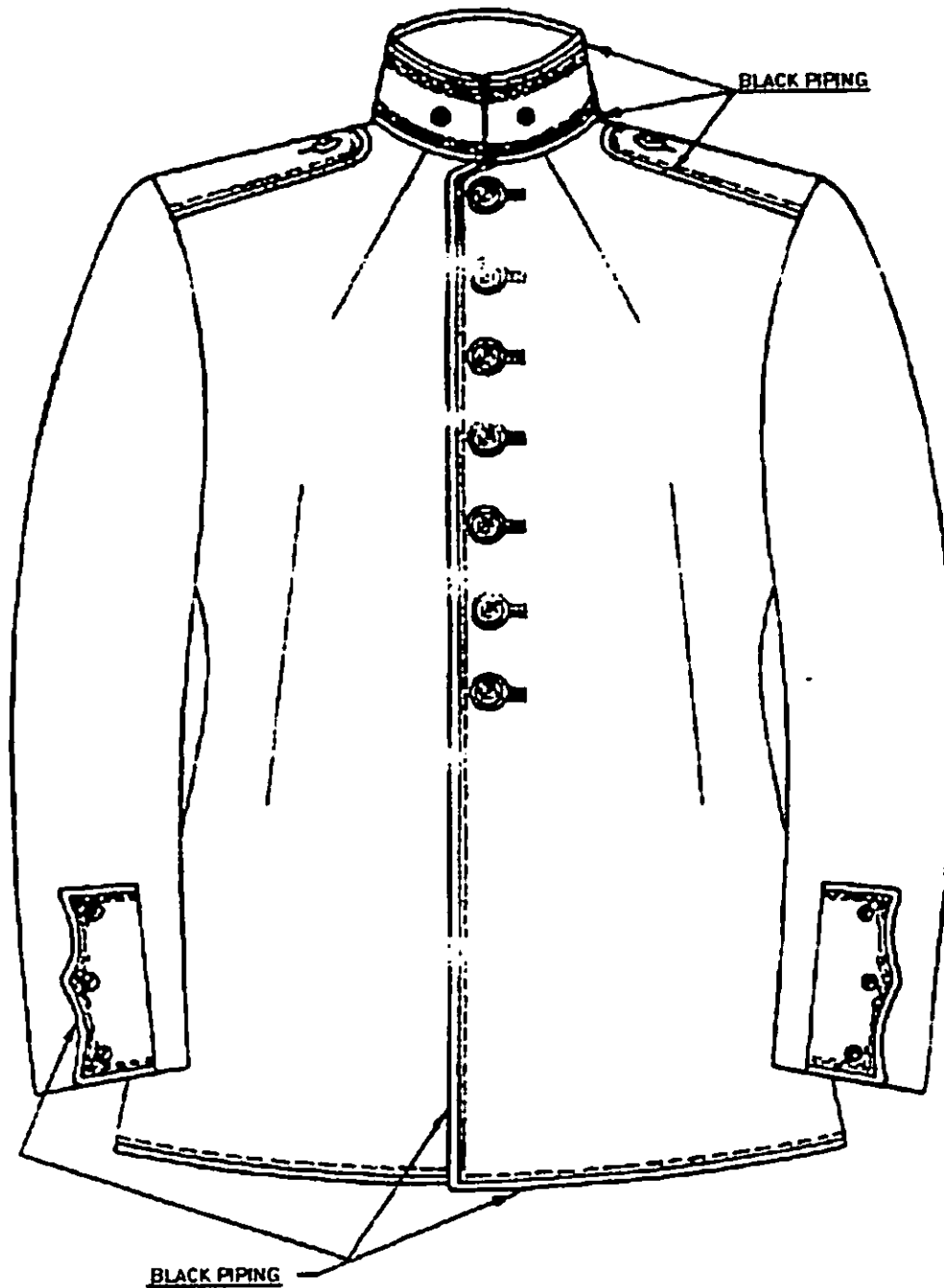

Figure 1. Coat, Man's, Scarlet, Drum and Bugle Corps, Musician

MIL-DTL-82156D (MC)

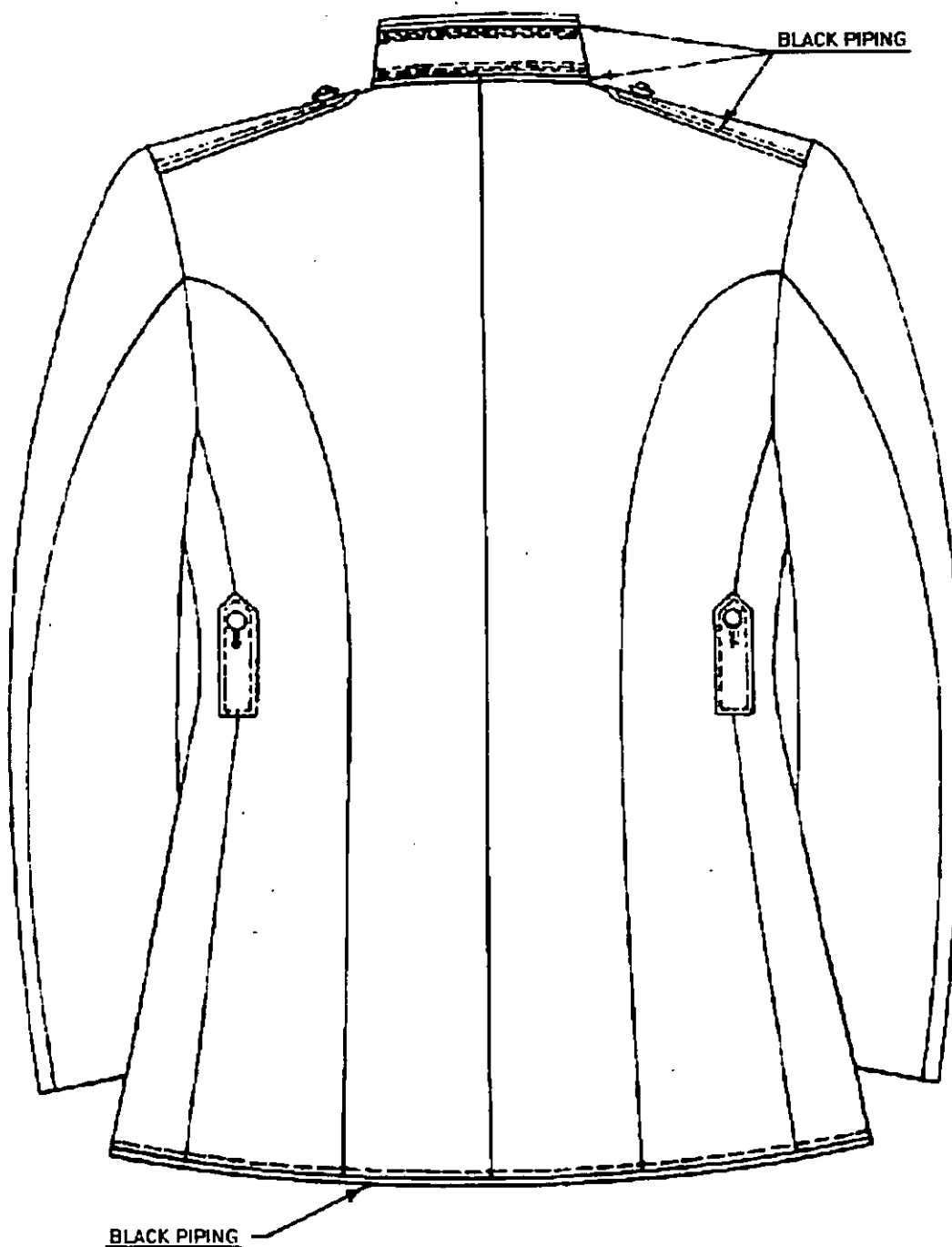

Figure 2. Coat, Man's, Scarlet, Drum and Bugle Corps, Musician

MIL-DTL-82156D (MC)

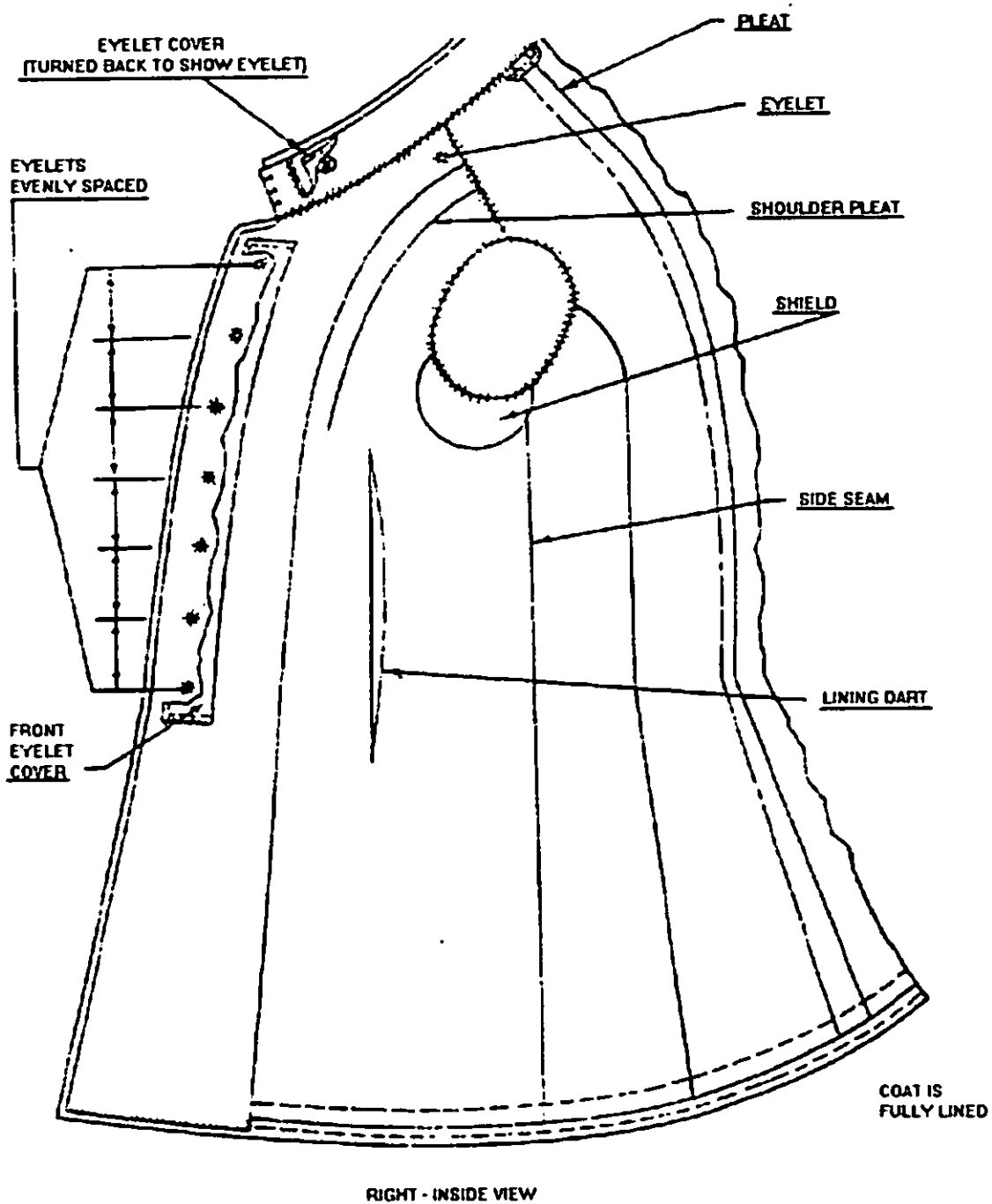

Figure 3. Coat, Man's, Scarlet, Drum and Bugle Corps, Musician

MIL-DTL-82156D (MC)

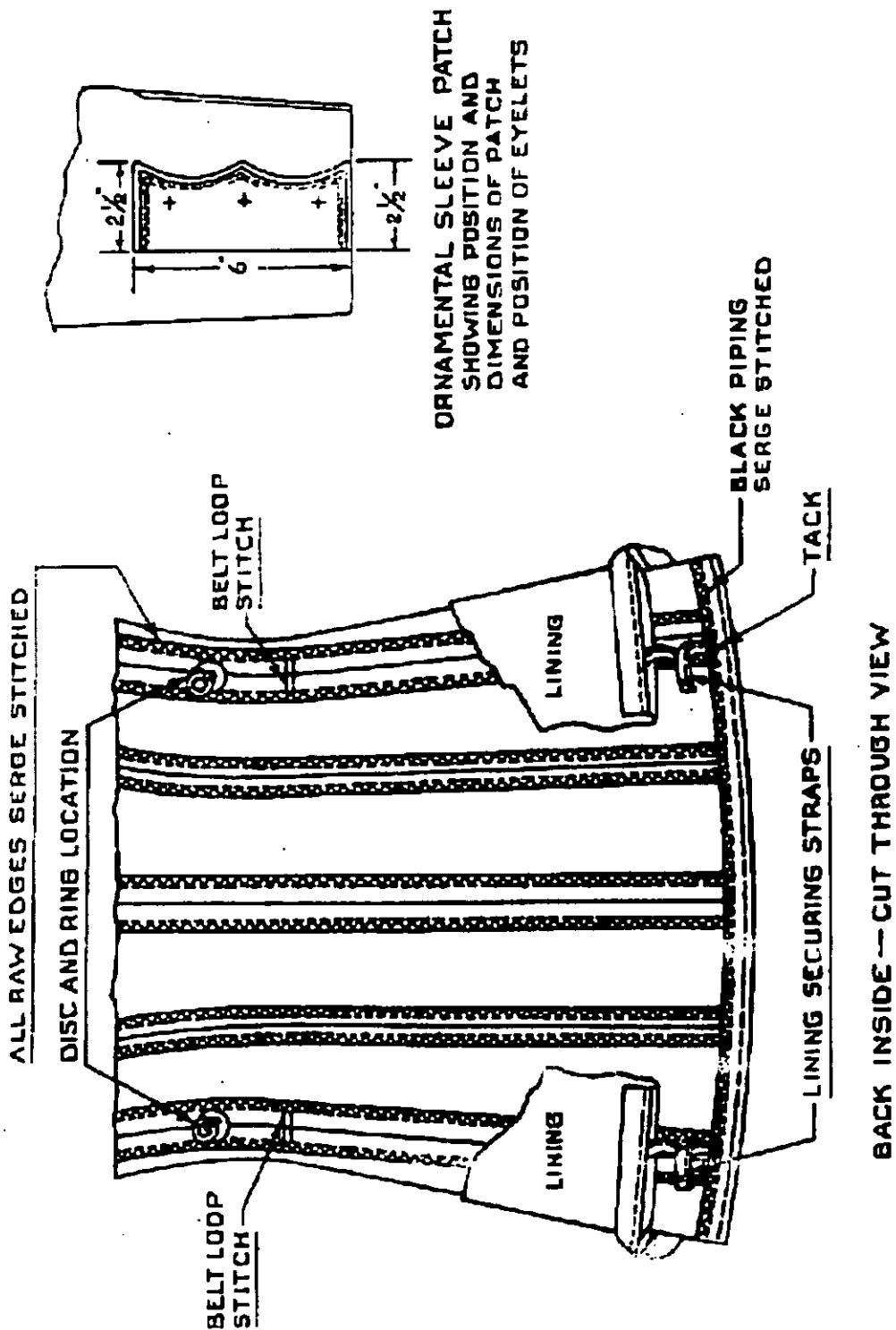

Figure 4. Coat, Man's, Scarlet, Drum and Bugle Corps, Musician

MIL-DTL-82156D (MC)

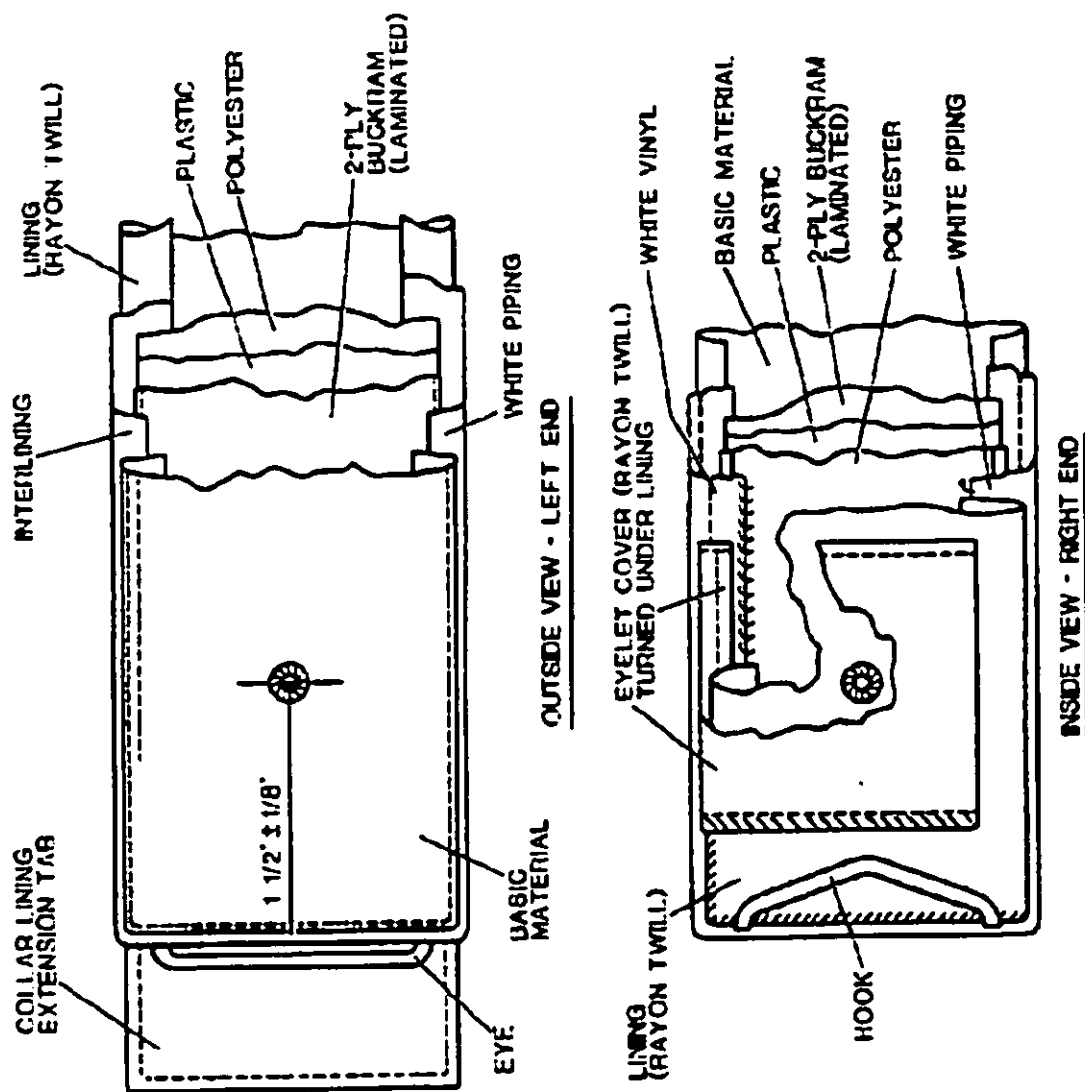

Figure 5. Coat, Man's, Scarlet, Drum and Bugle Corps, Musician

MIL-DTL-82156D (MC)

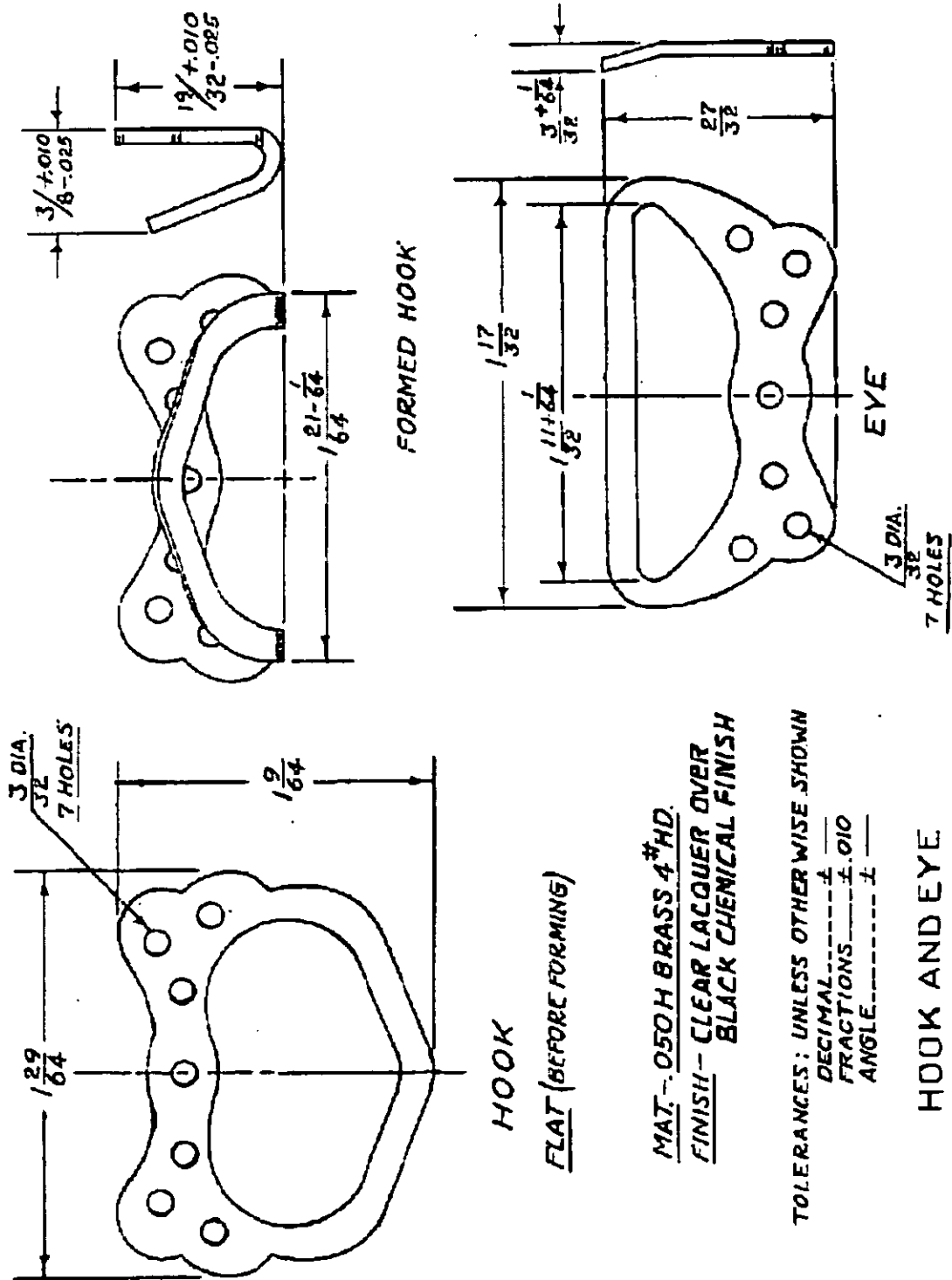

Figure 6. Coat, Man's, Scarlet, Drum and Bugle Corps, Musician

STANDARDIZATION DOCUMENT IMPROVEMENT PROPOSAL**INSTRUCTIONS**

1. The preparing activity must complete blocks 1, 2, 3, and 8. In block 1, both the document number and revision letter should be given.
2. The submitter of this form must complete blocks 4, 5, 6, and 7.
3. The preparing activity must provide a reply within 30 days from receipt of the form.

NOTE: This form may not be used to request copies of documents, nor to request waivers, or clarification of requirements on current contracts. Comments submitted on this form do not constitute or imply authorization to waive any portion of the referenced document(s) or to amend contractual requirements.

I RECOMMEND A CHANGE:

1. DOCUMENT NUMBER
MIL-DTL-82156D (MC)

2. DOCUMENT DATE (YYMMDD)
97 10 29

3. DOCUMENT TITLE

COAT, MAN'S - SCARLET, DRUM AND BUGLE CORPS, MUSICIAN'S

4. NATURE OF CHANGE (Identify paragraph number and include proposed rewrite, if possible. Attach extra sheets as needed.)**5. REASON FOR RECOMMENDATION****6. SUBMITTER**

a. NAME (Last, First, Middle Initial)

b. ORGANIZATION

c. ADDRESS (Include Zip Code)

d. TELEPHONE (Include Area Code)

7. DATE SUBMITTED
(YYMMDD)

(1) Commercial

(2) AUTOVON

If applicable

8. PREPARING ACTIVITY

a. NAME
COMMANDER, MARCORSYSCOM, PSE-D

b. TELEPHONE (Include Area Code)

(1) Commercial
(703) 784 4584

(2) AUTOVON
(000) 278 4584

c. ADDRESS (Include Zip Code)
2033 BARNETT AVE, SUITE 315
QUANTICO, VA 22134-5010

IF YOU DO NOT RECEIVE A REPLY WITHIN 45 DAYS, CONTACT:
Defense Quality and Standardization Office
5203 Leesburg Pike, Suite 1403, Falls Church, VA 22041-3488
Telephone (703) 758-2340 Autovon 289-2340