

NOT MEASUREMENT
SENSITIVE

MIL-DTL-81748E(AS)
10 December 2004

SUPERSEDING
MIL-DTL-81748D(AS)
15 December 1995

DETAIL SPECIFICATION

MANUALS, TECHNICAL: RAPID ACTION CHANGES AND INTERIM RAPID ACTION CHANGES; PREPARATION OF; GENERAL SPECIFICATION FOR

This specification is approved for use by the Naval Air Systems Command, and is available for use by all Departments and Agencies of the Department of Defense.

1. SCOPE

1.1 Scope. This specification covers the requirements for the preparation of Rapid Action Changes (RACs) and Interim Rapid Action Changes (IRACs) to Technical Manuals (TMs) under the cognizance of the Naval Air Systems Command (NAVAIRSYSCOM) (see 6.1.1, 6.1.2, and 6.1.3 for information pertaining to applicability, exceptions, and exclusions).

1.2 Classification. Rapid Action Changes to Technical Manuals covered by this specification shall be of the following types:

- a. RAC - issued by Naval activities or Contract Administrative Offices (CAOs) as a complete formal change to a TM (including all associated front matter).
- b. IRAC - issued by Naval activities or Contract Administrative Offices (CAOs) as an interim change to provide urgent TM change data.

Comments, suggestions, or questions on this document should be addressed to: Commander, Naval Air Systems Command, Code 49100B120-3 Highway 547, Lakehurst, NJ. 08733-5100 or emailed to thomas.omara@navy.mil. Since contact information can change, you may want to verify the currency of this address information using the ASSIST Online database at <http://assist.daps.dla.mil/>.

AMSC N/A

AREA TMSS

MIL-DTL-81748E(AS)

(1) Type A IRAC – issued as a Naval Message to provide urgent TM change data, with the exception of graphic images, schematics, wiring diagrams, etc., which are not for delivery by Naval Message.

(2) Type B IRAC – issued as hard copy or digital file to provide urgent TM changes for schematics, wiring diagrams, or other graphic images, which are not for delivery by Naval Message. Only the technical content change information is to be provided. The manual title page and front matter are not to be included. Type B IRACs are preceded with a Naval Message Release Notification.

2. APPLICABLE DOCUMENTS

2.1 General. The documents listed in this section are specified in sections 3 and 4 of this specification. This section does not include documents cited in other sections of this specification or recommended for additional information or as examples. While every effort has been made to ensure the completeness of this list, document users are cautioned that they must meet all specified requirements of documents cited in sections 3 and 4 of this specification, whether or not they are listed.

2.2 Government Documents.

2.2.1 Specifications, standards, and handbooks. The following specifications, standards, and handbooks form a part of this document to the extent specified herein. Unless otherwise specified, the issues of these documents are those cited in the solicitation or contract.

DEPARTMENT OF DEFENSE SPECIFICATIONS

- | | | |
|---------------|---|---|
| MIL-DTL-23618 | - | Manuals, Technical: Periodic Maintenance Requirements, Preparation of |
| MIL-DTL-81927 | - | Manuals, Technical: Work Package Style, Format, and Common Technical Content Requirements; General Specification for (Work Package Concept) |
| MIL-M-85337 | - | Manuals, Technical: Quality Assurance Program, Requirements for |

DEPARTMENT OF DEFENSE STANDARDS

- | | | |
|---------------|---|---|
| MIL-STD-38784 | - | Standard Practice for Manuals, Technical: General Style and Format Requirements |
|---------------|---|---|

DEPARTMENT OF DEFENSE HANDBOOKS

- | | | |
|-----------------|---|--|
| MIL-HDBK- 38790 | - | Printing Production of Technical Manuals |
|-----------------|---|--|

(Copies of these documents are available online at <http://assist.daps.dla.mil/quicksearch/> or <http://assist.daps.dla.mil/> or from the Standardization Document Order Desk, 700 Robbins Avenue, Building 4D, Philadelphia, PA 19111-5094.)

MIL-DTL-81748E(AS)

2.2.2 Other government documents, drawings, and publications. The following other government documents, drawings, and publications form a part of this document to the extent specified herein. Unless otherwise specified, the issues of these documents are those cited in the solicitation or contract.

NAVAL PUBLICATIONS

- NTP 3 (J) - Naval Telecommunication Procedures,
Telecommunications Users Manual

(Copies of this document are available from the Commander, Naval Computer and Telecommunications Command, N31, 4401 Massachusetts Avenue N.W., Washington, D.C. 20394-5460 or online at <http://www.nctsw.navy.mil/> .)

NAVAL AIR SYSTEMS COMMAND

- NAVAIR 00-25-100 - Naval Air Systems Command Technical Manual
Program

(Copies of this document are available from the Commanding Officer (ATTN: 3.3) Naval Air Technical Data and Engineering Service Command (NATEC), NAS North Island, Bldg 90, P.O.Box 357031, San Diego, CA. 92135-7031, or online at <https://www.natec.navy.mil/> .)

2.3 Order of Precedence. In the event of a conflict between the text of this document and the references cited herein, the text of this document takes precedence. Nothing in this document, however, supersedes applicable laws and regulations unless a specific exemption has been obtained.

3. REQUIREMENTS

3.1 Approved conditions for issuance of RACs or IRACs. RACs and IRACs shall be developed to expedite the issuance of technical information when one or more of the following conditions exist:

- a. Hazards to safety of personnel (see 6.4.4);
- b. Impairment of safety of flight (see 6.4.5);
- c. Aircraft grounding (see 6.4.1);
- d. Mission capability or fleet readiness (see 6.4.6);
- e. Equipment damage (see 6.4.3), or
- f. Environmental impact restrictions (see 6.4.2).

3.2 Conditions not approved for issuance of RACs and IRACs. A RAC or IRAC shall not be issued for the following:

- a. Update of data pertaining to hardware familiarization, such as: theory of operation; description of an existing unit or control unless required in conjunction with revised installation, assembly, disassembly, or maintenance procedures;

MIL-DTL-81748E(AS)

- b. Format changes;
- c. Grammatical changes (unless safety, equipment damage, flight limitation, etc, are involved);
- d. Typographical errors;
- e. General non-procedural information;
- f. Naval Air Training and Operation Standardization (NATOPS) flight and tactical manuals. These are excluded from this specification. Refer to OPNAVINST 3710.7.

3.3 RAC/IRAC Determination. The determination to issue a RAC or an IRAC shall be made by the cognizant TM preparing activity in coordination with the program Technical Data Logistic Element Manager (LEM). Formal Revisions and Changes are the preferred means of distributing change data to the user community in order to maintain effective configuration control throughout the TM update and distribution process, and for ease of use by the maintainer. RACs provide similar benefits to the maintenance community, and are preferred where circumstances warrant their use.

3.3.1 RACs. RACs are complete, formal changes to applicable technical manuals. In addition to the pertinent technical content change information, RACs provide all the associated technical manual format data, such as title page, front matter, indices, etc. RACs shall be used to disseminate urgent TM change information when funding, contractual and programmatic conditions make their use practical. Distribution of electronic and hard copy RACs shall be in accordance with current NATEC web-posting guidelines found on NATEC Technical Manual Application System (TMAPS) website. The affected program's LEM shall coordinate any deviation from NATEC requirements for initial printing and distribution.

3.3.2 IRACs. IRACs may be used when funding, contractual and programmatic circumstances make the use of RACs impractical. Formal incorporation of an IRAC into the TM is still required and must be accomplished by a formal change, revision or RAC. IRACs are of two (2) types:

a. Type A: shall be used to disseminate information for distribution by Naval Message. Upon receipt of an applicable Type A IRAC, technical manual users are directed to annotate the IRACs applicability to effected pages and maintain the IRAC behind the title page of the manual. Generally, Type A IRACs provide information that applies to text and routine tabular information. Type A IRACs shall not be used for any form of illustrations, schematics, wiring diagrams, or other graphics images.

b. Type B: shall be used to disseminate information that includes illustrations, schematics, wiring diagrams, and other forms of graphic data that cannot be included in a Type A IRAC. Type B IRACs are preceded with a naval message notification. Technical manual users are directed to maintain the notification message behind the title page of applicable manual until receipt of Type B IRAC. Upon receipt of an applicable Type B IRAC, technical manual users are directed to insert enclosed change pages in accordance with NAVAIR 00-25-100. The notification message is removed and the applicable cover letter is maintained behind the existing title page and additional effected pages are annotated as applicable. Type B IRACs shall be

MIL-DTL-81748E(AS)

developed in a manner that allows the fleet user to download and print them from the NATEC website, so that the user can easily insert and replace them within the existing TM.

3.4 TM Incorporation. RACs and IRACs shall be collated into affected TMs immediately upon receipt. IRACs shall be formally incorporated into affected TMs during the next formal update but no later than 12 months after their release date whichever comes first. This shall be accomplished by issuance of a routine change, revision or pickup revision, in conjunction with the incorporation of additional source data, as applicable.

a. Formal updates shall include incorporation of all outstanding IRACs pertaining to the TM. IRACs not incorporated during the update shall be cancelled and reissued against the updated TM using a new IRAC number. See 3.5.3 for procedures covering cancelled RAC and IRAC numbers.

3.5 RAC and IRAC identification.

3.5.1 RAC and IRAC numbering. RACs and IRACs shall be numbered consecutively throughout the life of the TM beginning with RAC or IRAC number 1. All numbers shall be assigned by the Technical Data Logistics Element Manager (LEM) or designee approved by the program LEM.

3.5.2 RAC and IRAC date.

a. The RAC date shall be the cut-off date (copy freeze date) of the technical data being included in the RAC.

b. The IRAC Type A date shall be the Date Time Group (DTG) of the Naval Message.

c. The IRAC Type B date shall be the cut-off date (copy freeze date) of the technical data being included in the IRAC.

3.5.3 Cancelled RAC and IRAC numbers.

a. If a RAC is issued with incorrect data, it shall be corrected by issuing the next RAC numbered in sequence with only the affected pages corrected. The TM title page shall contain a supersedure statement, which reads, "This RAC supersedes RAC No_." Minor errors not affecting technical content may be corrected by issuing a NAVAIR TM Notice.

b. When a Type A IRAC is issued with obsolete, incorrect, or incomplete data, it shall be cancelled and superceded by a new IRAC. The new IRAC shall reference the IRAC number and date or Date Time Group (DTG) of any previous IRACs it cancels and in the 'Related Information' paragraph state that "Reference X is cancelled and superceded by this IRAC." Cancelled IRAC numbers shall not be reused.

c. When a Type B IRAC is issued with obsolete, incorrect, or incomplete data, it shall be corrected by issuing the next IRAC number in sequence with the affected pages corrected.

MIL-DTL-81748E(AS)

d. IRACs not incorporated during a manual update, or received after the technical manual data cutoff date (copy freeze date), shall be cancelled and the data reissued as a new IRAC, using a new IRAC number against the current change or revision of the affected manual.

NOTE: In all cases where a RAC or IRAC is cancelled, the user shall receive all information that may have been previously discarded as a result of the direction given in the cancelled RAC or IRAC. This will ensure users have all pertinent data, regardless of the issuance and subsequent cancellation of a RAC or IRAC.

3.6 IRAC/RAC Preparation.

3.6.1 IRAC.

a. Type A: shall be prepared using the Naval Message format. Type A IRACs should normally not exceed five pages (excluding distribution).

b. Type B: issued by Naval activities/CAOs as hard copy shall be preceded by a Naval Message informing users of the subsequent mailing date of the Type B IRAC letter number and its date.

3.6.1.1 Type A IRAC format and arrangement. Format requirements for naval messages are defined in NTP 3 (J), Naval Telecommunications Procedure, Telecommunications User Manual. The following shall be included and formatted in accordance with the NTP 3 (J) procedures manual (see figure 1 as an example):

a. IRAC issuing activity information. The Naval Message shall contain the Plain Language Address Designator (PLAD) and code of the issuing activity.

b. Action addressee. The Naval Message shall include, but not be limited to, Address Indicator Group (AIG) number 165 and any supplemental AIGs that may be involved if such an AIG has been established. The following shall be addressed in the information line: Commander, Naval Air Pacific and Atlantic Fleets; Commander, Naval Training Activity; Commander, Naval Air Reserve Force; and Commander, Naval Air Systems Command.

c. Security classification. The security classification of an IRAC shall be determined from the content of the change. Classification of the IRAC shall not exceed the classification of the affected TM. The security classification of an IRAC can be lower, but not higher, than the security classification of the TM being changed. Security marking shall be in accordance with current security.

d. Standard Subject Identification Code (SSIC). The SSIC for IRAC messages shall be "5600" as they pertain to NAVAIRINST 5600.23, Policy, Procedures, and Responsibilities for Technical Manual Rapid Action Change Program.

MIL-DTL-81748E(AS)

e. Subject. The subject of the IRAC shall be, “INTERIM RAPID ACTION CHANGE NO. (IRAC number) TO TECHNICAL MANUAL (NAVAIR TM number and title) OF (date of issue) WITH (latest formal change number and date if applicable).”

f. References. “NAVAIR 00-25-100.” Other references shall be included as necessary.

g. Responsible Code. Information concerning the person(s) responsible for the IRAC shall be provided, including: name, activity name, code, DSN and commercial phone numbers, fax number, and e-mail address.

h. Condition and purpose of change. The IRAC shall state the specific condition and the purpose of the change, as follows:

“TO CORRECT/PREVENT (cite condition based on section 3.1 above and provide a brief explanation)”. Example: To correct/prevent an equipment damage condition by providing new operational test procedures that eliminates the potential for damage.

i. Detailed information.

(1) The following shall be included verbatim in all IRACs as the lead-in sentences addressing the technical content changes:

“Pen and ink changes to the technical content of a manual are not authorized. The following technical content change information applies to the following referenced pages and paragraphs of the subject manual until the formal update is released.”

(2) The exact location and description of the change shall be written in detail.

(3) The text of the IRAC shall be clear, accurate, concise, and shall be worded in the same style and format as the affected publication. Good judgment shall be used to maintain continuity of the actions to be taken and adequately cover the intended change.

j. Validation. IRACs shall be validated in accordance with MIL-M-85337 prior to release. The name of the person who performed validation of the IRAC, including activity name, code, telephone number, and email address shall be provided in the IRAC.

k. Related instructions. Direction to maintain the Type A IRAC with the applicable manual shall be included when applicable, as quoted below:

(1) “For IRACs affecting manuals in paper copy – maintain this IRAC with the applicable manual by placing or attaching it directly behind the title page. Mark the specific area affected and annotate the changed page or card listed on the A page with a vertical line in the margin next to the changed data opposite the binding. For double column material mark the center margin when the inner paragraph is affected. Note the IRAC number in the margin. This IRAC shall not be removed until receipt of a formal change pages.”

MIL-DTL-81748E(AS)

(2) “For IRACs affecting manuals that are on CD-ROM – affix an adhesive label to the CD-ROM case annotated with the applicable publication number and IRAC number. The label should be positioned to allow for additional IRACs as they occur and should not cover the date or CD title. Maintain the IRAC on file until receipt of the superseding CD-ROM.”

(3) The preparing activity, point of contact, code, and target date for incorporating the IRAC into the affected manual (no later than 12 months from the date of IRAC issue) shall be indicated.

3.6.1.2 Type B IRAC release notification message format and arrangement. All Type B IRACs shall be preceded by a release notification in naval message format. Format requirements for naval messages are defined in NTP 3 (J), Naval Telecommunications Procedure, Telecommunications User Manual. The following shall be included and formatted in accordance with the NTP 3 (J) procedure manual (see figure 2 as an example):

a. IRAC issuing activity information. The Naval Message shall contain the Plain Language Address Designator (PLAD) and code of the issuing activity.

b. Action Addressee. The Naval Message shall include, but not be limited to, Address Indicator Group (AIG) number 165 and any supplemental AIGs that may be involved if such an AIG has been established. The following shall be addressed in the information line: Commander, Naval Air Pacific and Atlantic Fleets; Commander, Naval Training Activity; Commander, Naval Air Reserve Force; and Commander, Naval Air Systems Command.

c. Security Classification. “Unclassified.”

d. Standard Subject Identification Code (SSIC). The SSIC for IRAC messages shall be “5600” as they pertain to NAVAIRINST 5600.23, Policy, Procedures, and Responsibilities for Technical Manual Rapid Action Change Program.

e. Subject. The subject shall be: “Release notification of interim rapid action change no. (IRAC number) to technical manual (NAVAIR TM number and title) OF (date of issue) with (latest formal change number and date if applicable)”.

f. References. “NAVAIR 00-25-100”. Other references shall be included as necessary.

g. Point of Contact (POC). Information concerning the person(s) responsible for the IRAC shall be provided, including: name, activity name, code, DSN and commercial phone numbers, fax number, and e-mail address.

h. Condition and Purpose of Change. The message shall state the specific condition and purpose of the change as it will be stated on the formal, hard copy TYPE B IRAC when released, as follows:

MIL-DTL-81748E(AS)

“TO CORRECT/PREVENT (cite condition based on section 3.1 above and provide a brief explanation)”. Example, “To correct/prevent an Equipment damage condition by providing new operational test procedures which eliminate the potential for damage.”

i. Detailed information.

(1) The following shall be included verbatim:

“In accordance with reference A, this message precedes the hard copy of subject Type B IRAC which will be distributed to all activities per the Automatic Distribution Requirements List (ADRL) for the applicable manual and will be available for electronic download from the Naval Air Technical Data and Engineering Service Command (NATEC) website at <https://www.natec.navy.mil/>.”

“All IRACs received prior to receipt of subject Type B IRAC shall be maintained in the applicable manual in accordance with reference A.”

j. Related Instructions. Direction to maintain the Type B release notification message with the applicable manual shall be verbatim as follows:

(1) “For IRACs affecting manuals in paper copy – maintain this Type B IRAC release notification with the applicable manual by placing or attaching it directly behind the title page. This message shall not be removed until receipt of applicable formal Type B IRAC.”

(2) “For IRACs affecting manuals that are on CD-ROM – affix an adhesive label to the CD-ROM case annotated with the applicable publication number and IRAC number. The label shall be positioned to allow for additional IRACs as they occur and shall not cover the date or CD title. Maintain this release notification on file until receipt of the superseding CD-ROM.”

3.6.1.3 Type B IRAC cover letter format and arrangement. (See figure 3). Prepared as hard copy/reproducible copy pages or other media acceptable to the applicable printing activity. A formal Naval letter shall be used as the cover sheet with the IRAC listed as the enclosure. Type B IRACs shall be delivered for printing within 10 working days after resolution of the required corrective action.

a. Security markings shall be in accordance with current regulations and MIL-DTL-23618, MIL-STD-38784, MIL-DTL-81927, or the general requirement specifications used to prepare the TM.

b. Replacement pages or added pages shall be prepared in the same style and format as the existing TM. Change symbols shall be applied as specified in the applicable general requirement specification used to prepare the TM.

c. The letters "IRAC" shall appear before the IRAC number, followed by the IRAC date and shall be listed under the manual number opposite the applicable page numbers in the same

MIL-DTL-81748E(AS)

manner as normal change numbers. Each replacement or added page or card shall reflect only its latest change or IRAC number (see figure 4).

d. Replacement and backup pages shall be assigned the same page number(s) as the page(s) they are replacing in the TM. To maintain compatibility with existing page number sequencing, suffix letters shall be used for added pages.

e. The cover sheet shall be constructed to provide a title block measuring approximately 6¼ X 1¼ inches across the top of the page. The title block shall be encapsulated and contain “INTERIM RAPID ACTION CHANGE” in bold type capital letters. The cover sheet shall contain:

(1) Date

(2) Category: (Priority or Urgent)

(3) From: (Issuing Activity)

(4) To: (Addressees as developed from the applicable Automatic Distribution Requirements List (ADRL). Example: F/A-18A ADRL for A1-F18AC-XXX-XXX.)

(5) Subject: The subject of the Type B IRAC cover letter shall be, “INTERIM RAPID ACTION CHANGE NO. (IRAC number) TO TECHNICAL MANUAL (NAVAIR number and title) OF (date of issue, change number, and date as applicable).”

(6) References: (as required)

(7) Enclosure(s): Identify all replacement /added pages as enclosures. Logically group enclosures for clarity. Work package manual example: Enclosure (1) WP 018 00, pages 2 and 89 through 94, Enclosure (2) WP 021, pages 5 and 6. Maintenance Requirement Card deck example: Enclosure (1) Cards 11 through 24, Enclosure (2) Cards 61 and 62.

(8) Point of Contact (POC): The name, title, phone number, email address, activity name, and office code of the person(s) responsible for the IRAC shall be provided. If more than one POC is identified, complete information shall be provided for each.

(9) Condition and Purpose of Change. The IRAC shall state the specific condition and the purpose of the change, as follows:

“TO CORRECT/PREVENT (cite condition based on Section 3.1 above and provide a brief explanation).” Example, To correct/prevent a Hazard to Safety of Personnel condition by providing new procedures which eliminates the potential hazard.

(10) Detailed information:

MIL-DTL-81748E(AS)

(a) The following statement shall be included verbatim as the lead-in sentences introducing the technical content changes:

“Pen and ink changes to the technical content of a manual are not authorized. The following technical content change information applies to the referenced pages, paragraphs, and figures of the subject manual until the formal update is released.”

(b) Instructions for incorporating the enclosures shall be provided. If applicable, the text of technical content changes shall be clear, accurate, concise, and shall be worded in the same style and format as the data to be inserted into the publications. Good judgment shall be used to maintain continuity of the actions to be taken and adequately cover the intended change.

(11) Validation. Type B IRACs shall be validated in accordance with MIL-M-85337 for accuracy prior to release. Activity name, activity code, POC name, and POC telephone number shall be provided as applicable.

(12) Related Instructions: Directions to maintain the IRAC with the applicable manual shall be verbatim as follows:

“For IRACs affecting manuals in paper copy – Maintain this IRAC with the applicable manual by placing or attaching the cover letter directly behind the title page. Mark the specific change area in the margin of each page affected and annotate the changed page or card listed on the A Page with a vertical line and the IRAC number. Replacement page(s) shall be inserted as directed in paragraph 2.b. This Type B IRAC shall not be removed until receipt of the formal update.”

“For IRACs affecting manuals on CD-ROM – affix an adhesive label to the CD-ROM case annotated with the applicable publication number and IRAC number. The label shall be positioned to allow for additional IRACs as they occur and shall not cover the date or CD title. Maintain the IRAC on file until receipt of the superseding CD-ROM.”

(13) The preparing activity, point of contact, code, and target date for incorporating the IRAC into the affected manual (no later than 12 months from the date of IRAC issuance) shall be indicated. Example, Subject IRAC shall be incorporated into applicable manual no later than 12 months after IRAC issue date (or next formal change) by (insert activity, name, and code).

3.6.2 RAC. RACs shall be prepared as reproducible copy or other media acceptable to the applicable printing activity. Replacement pages or added pages are to be prepared in the same style and format as the affected TM.

3.6.3 RAC format and arrangement. RACs shall consist of a title page, list of effective work packages/pages/cards ("A" page/card), changed text pages and illustration pages as required.

MIL-DTL-81748E(AS)

- a. The title page of the RAC shall match the basic format of the existing title page. The words Rapid Action Change, the RAC number, and RAC date shall appear on the title page below the issue or revision date (see figure 5).
- b. The "A" page/card shall contain a listing of changed work package/page/cards. The listing shall provide the numbers and dates of all rapid action changes and routine changes issued against the basic TM or the latest revision. "RAC" shall appear before the RAC number, and shall be listed opposite the applicable page numbers in the same manner as normal change numbers or zeros (denoting the basic manual or current revision). Each work package, page or card listed shall reflect only its latest change or RAC number (see figures 6, 7 and 8).
- c. Text and illustration pages shall be in accordance with the general requirements and technical content specifications used to prepare the TM being changed. The pages shall be prepared to add, delete, and change information in a manner that will best afford expediency, clarity, and coherency. New or changed illustrations shall meet or exceed the quality of the existing illustration.
- d. Replacement pages shall be assigned the same numbers as the TM pages they replace. Added pages shall be assigned numbers compatible with the existing page sequencing and shall bear letter suffixes based on the general requirement specification used to prepare the affected TM.
- e. Change symbols shall be applied as specified in the applicable general requirement specification used to prepare the TM.
- f. The security classification of the RAC shall be determined from the content of the change. Classification of the RAC cannot exceed the classification of the affected TM. Security markings shall be in accordance with current security regulations and MIL-DTL-23618, MIL-STD-38784, MIL-DTL-81927, or the general requirement specification used to prepare the TM.

3.7 Maintaining status of RACs or IRACs. The title and "A" pages of changed TMs and all subsequent revisions shall include all incorporated RACs of previous editions (see figure 6).

- a. IRACs incorporated by a TM change or revision shall be included on the "A" page of the applicable TM.
- b. The "A" pages of all subsequent TM changes and revisions shall reflect the cumulative status of all IRACs and RACs issued and incorporated.
- c. Cancelled IRAC numbers, including those assigned but never issued, shall be reflected on the "A" page.
- d. When an IRAC cancels a previous IRAC and there is no impact on the technical content of the manual, e.g., original requirements reinstated, the IRAC will be identified on the "A" page of the manual as follows:

MIL-DTL-81748E(AS)

IRAC 4.....Cancelled

IRAC 5.....See Note

A note shall be placed below the List of Current Changes as follows:

Note: IRAC 5 cancelled IRAC 4. No impact on technical content. For record purposes only.

3.8 Printing. RAC printing and printing schedule requirements shall be in accordance with MIL-HDBK-38790.

3.9 Electronic Availability. Digital copies of IRACs shall be forwarded to NATEC within one (1) business day. A digital copy of the entire TM with the IRAC or RAC digitally inserted shall be provided to NATEC by the originator for posting to the NATEC web site within 3 business days. (Refer to Naval Air Technical Data and Engineering Service Command Technical Manual Conversion Guidelines).

4. VERIFICATION This section is not applicable to this specification.

5. PACKAGING

5.1 Packaging. For acquisition purposes, the packaging requirements shall be as specified in the contract or order (see 6.2). When packaging of materiel is to be performed by DoD or in-house contractor personnel, these personnel need to contact the responsible packaging activity to ascertain packaging requirements. Packaging requirements are maintained by the Inventory Control Point's packaging activities within the Military Service or Defense Agency, or within the military service's system commands. Packaging data retrieval is available from the managing Military Department or Defense Agency's automated packaging files, CD-ROM products, or by contacting the responsible packaging activity.

6. NOTES

(This section contains information of a general or explanatory nature that may be helpful, but is not mandatory.)

6.1 Intended use. RACs and IRACs will be used only to expedite the issuance of essential operational and maintenance change information as specified in 3.1 (and clarified in the definitions below). Refer to NAVAIRINST 5600.23 for a definition of the policy, procedures, and responsibilities of the TM RAC program.

6.1.1 Applicability. RACs and IRACs are applicable to technical manuals supporting all in-production and out-of-production NAVAIR weapons systems such as: maintenance instruction manuals, related component equipment manuals, maintenance requirement cards, illustrated parts breakdown, support equipment, weapons handling and loading manuals, calibration manuals, and other related procedural manuals.

MIL-DTL-81748E(AS)

6.1.2 Exceptions.

6.1.2.1 Electronic Rapid Action Changes (ERACs). ERACs support the sustainment of Interactive Electronic Technical Manuals (IETM) and accomplish the purpose and function of IRACs in a digital format. ERACs meet the electronic requirements of specific platforms and are issued in accordance with those conditions warranting an IRAC as defined in this specification. Individual program requirements dictate the presentation systems used to display ERACs and drive the specific format of those ERACs issued. Although not identified in this document, and until a formal ERAC standard is established, platforms should develop their ERAC processes in accordance with this detail specification to the fullest extent practical.

6.1.3 Exclusions.

6.1.3.1 NATOPS. Naval Air Training and Operation Procedures Standardization (NATOPS) flight manuals and tactical manuals are excluded from the RAC and IRAC program (OPNAVINST 3710.7 refers).

6.2 Acquisition requirements. Acquisition documents should specify the following:

- a. Title, number, and date of the specification.
- b. The specific issue of individual documents referenced (see 2.2.1). The general requirements specification used to prepare the technical manual shall also be specified.
- c. Name and address of requiring DoD activity assigned TM cognizance.
- d. Name and address of the cognizant TM preparing activity if different than 6.2.c.
- e. Packaging requirements (see 5.1).

6.3 Technical manuals. The requirement for technical manuals should be considered when this specification is applied on a contract. If technical manuals are required, specifications and standards that have been authorized and assigned an Acquisition Management Systems Control (AMSC) number must be listed on a separate Contract Data Requirements List (DD Form 1423), which is included as an exhibit to the contract. The technical manuals must be acquired under separate contract line item in the contract.

6.4 Definitions.

6.4.1 Aircraft grounding. A change affecting equipment operation which, if not incorporated, would result in an aircraft being grounded.

6.4.2 Environmental impact restrictions. Stringent environmental constraints have required that activities change or eliminate maintenance processes and materials that are no longer environmentally acceptable due to local or regional laws. A RAC or IRAC should be

MIL-DTL-81748E(AS)

prepared and issued in response to environmental impact restrictions to ensure weapon systems or equipment can be effectively maintained and mission capability is not impaired by noncompliance with environmental laws.

6.4.3 Equipment damage. Information related to significant equipment damage that, if not corrected, would cause equipment malfunction is justification for a RAC or IRAC.

6.4.4 Hazards to safety of personnel. A change pertaining to conditions which, if not corrected, would directly contribute to bodily injury that may result in loss of life, limb, or impairment of senses (sight, hearing, smell, taste, or touch). Injuries such as bruises, scratches, pinched fingers, and discomfort caused by odors emanating from nontoxic substances should not be considered hazards that warrant a RAC or IRAC.

6.4.5 Impairment of safety of flight. A change pertaining to a subsystem (hydraulic, electrical, etc.), an assembly or component part, the failure or malfunction of which would result in the loss of an aircraft. Also pertains to a change correcting intermittent faulty operation of equipment or subsystems that might eventually result in a loss of an aircraft.

6.4.6 Mission capability/fleet readiness. Component or system failure or malfunction that prevents a weapon system or equipment from performing a specifically assigned mission. Changes in maintenance procedures; i.e. repair capabilities, expanded operating limits, etc. that reduce man-hour and material expenditures and increase readiness should also be justification for issuing a RAC or IRAC. In any case, the originator must determine whether the proposed change in operation or maintenance procedures will increase mission capability (thereby justifying a RAC or IRAC) or will merely improve procedures without affecting mission capability (in which case a RAC or IRAC is not justified).

6.5 Subject term (key word) listing.

Activity, Cognizant Field
 Activity, Cognizant Review
 Cards, Maintenance Requirement (MRC)
 Checklist
 Grounding, Aircraft
 Maintenance Instruction
 Personnel, Hazards to Safety of
 Readiness, Mission Capability/Fleet
 Restrictions, Environmental Impact
 Safety of Flight, Impairment of
 Type A, Change
 Type B, Change

6.6 Changes from previous issue. Marginal notations are not used in this revision to identify changes with respect to the previous issue due to the extent of the changes.

MIL-DTL-81748E(AS)

UUUUUUUUUUUUUUUUUUUUUUUUUUUUUU
 U UNCLASSIFIED U
 UUUUUUUUUUUUUUUUUUUUUUUUUUUUUUU

ADMINISTRATIVE MESSAGE

ROUTINE

PR (Date, Time, Group)
 FM (Issuing Activity, Code)

TO AIG ONE SIX FIVE
 (Any other supplemental AIGs for the specific equipment, as required)

INFO (As required)

UNCLAS //N05600//

MSGID/GENADMIN//

SUBJ/INTERIM RAPID ACTION CHANGE NO.() TO TECHNICAL MANUAL (NAVAIR number, title) OF (Date of issue) WITH (Change number and date, as applicable)//

REF/(As required)//

NARR/(As required)//

RMKS/1. RESPONSIBLE CODE: (Activity and office code)//

2. PURPOSE OF CHANGE: (Specifically define condition for message release as covered in paragraph 3.1 and purpose of change. Example: TO CORRECT/PREVENT A MISSION CAPABILITY/FLEET READINESS CONDITION PERTAINING TO T406 ENGINE LIFE LIMITED COMPONENTS.)//

3. DETAILED INFORMATION: PEN AND INK CHANGES TO THE TECHNICAL CONTENT OF A MANUAL ARE NOT AUTHORIZED. THE FOLLOWING TECHNICAL CONTENT CHANGE INFORMATION APPLIES TO THE FOLLOWING REFERENCED PAGES AND PARAGRAPHS OF THE SUBJECT MANUAL UNTIL THE FORMAL UPDATE IS RELEASED: (Identify exact location and describe the change in detail. Example: IN WORK PACKAGE 005 00, PAGE 6, DELETE STEPS 4 AND 5 IN THEIR ENTIRETY.)//

1 OF 2 (Date, Time, Group)
 (Issuing activity)

UUUUUUUUUUUUUUUUUUUUUUUUUUUUUU
 U UNCLASSIFIED U
 UUUUUUUUUUUUUUUUUUUUUUUUUUUUUUU

FIGURE 1. Example of a Type A IRAC.

MIL-DTL-81748E(AS)

UUUUUUUUUUUUUUUUUUUUUUUUUUUUUU
 U UNCLASSIFIED U
 UUUUUUUUUUUUUUUUUUUUUUUUUUUUU

4. VALIDATED BY: (Name, activity, code, and telephone number as applicable)//

5. RELATED INSTRUCTIONS:

A. FOR IRACS AFFECTING MANUALS IN PAPER COPY - MAINTAIN THIS IRAC WITH THE APPLICABLE MANUAL BY PLACING OR ATTACHING IT DIRECTLY BEHIND THE TITLE PAGE. MARK THE SPECIFIC AREA AFFECTED AND ANNOTATE THE CHANGED PAGE OR CARD LISTED ON THE A PAGE WITH A VERTICAL LINE IN THE MARGIN NEXT TO THE CHANGED DATA OPPOSITE THE BINDING. FOR DOUBLE COLUMN MATERIAL MARK THE CENTER MARGIN WHEN THE INNER PARAGRAPH IS AFFECTED. NOTE THE IRAC NUMBER IN THE MARGIN. THIS IRAC SHALL NOT BE REMOVED UNTIL RECEIPT OF THE FORMAL CHANGE PAGES.

B. FOR IRACS AFFECTING MANUALS ON CD-ROM - AFFIX AN ADHESIVE LABEL TO THE CD-ROM CASE ANNOTATED WITH THE APPLICABLE PUBLICATION NUMBER AND IRAC NUMBER. THE LABEL SHOULD BE POSITIONED TO ALLOW FOR ADDITIONAL IRACS AS THEY OCCUR AND SHOULD NOT COVER THE DATE OR CD TITLE. MAINTAIN THE IRAC ON FILE UNTIL RECEIPT OF THE SUPERSEDING CD-ROM.

C. (Preparing activity, code and target date for formally updating the applicable manual. Example: SUBJECT IRAC SHALL BE INCORPORATED INTO APPLICABLE MANUAL NO LATER THAN 12 MONTHS FROM THE DATE OF IRAC ISSUE)

D. (activity, code.)//

2 OF 2 (Date, Time,Group)
(Issuing activity)

UUUUUUUUUUUUUUUUUUUUUUUUUUUUUU
 U UNCLASSIFIED U
 UUUUUUUUUUUUUUUUUUUUUUUUUUUUU

FIGURE 1. Example of a Type A IRAC - Continued.

MIL-DTL-81748E(AS)

UUUUUUUUUUUUUUUUUUUUUU
 U UNCLASSIFIED U
 UUUUUUUUUUUUUUUUUUUUU

ADMINISTRATIVE MESSAGE

ROUTINE

PR (Date, Time, Group)
 FM (Issuing Activity, Code)

TO AIG ONE SIX FIVE
 (Any other supplemental AIGs for the specific equipment, as required)

INFO (As required)

UNCLAS //N05600//

MSGID/GENADMIN//

SUBJ/RELEASE NOTIFICATION OF INTERIM RAPID ACTION CHANGE NO. (IRAC number) TO TECHNICAL
 MANUAL (NAVAIR TM number and title) OF (date of issue) WITH (latest formal change number and date if applicable).

REF/NAVAIR 00-25-100 (Other references as required)//

NARR/(As required)//

RMKS/1. Point of Contact: (Activity and office code)//

2. PURPOSE OF CHANGE: (Specifically define condition for message release as covered in paragraph 3.1 and purpose of
 change. Example: TO CORRECT/PREVENT (cite condition based on section 3.1 and provide a brief explanation).

3. DETAILED INFORMATION: IN ACCORDANCE WITH REFERENCE A, THIS MESSAGE PRECEDES THE HARD
 COPY OF SUBJECT TYPE B IRAC WHICH WILL BE DISTRIBUTED TO ALL ACTIVITIES PER THE AUTOMATIC
 DISTRIBUTION REQUIREMENTS LIST (ADRL) FOR THE APPLICABLE MANUAL AND WILL BE AVAILABLE
 FOR ELECTRONIC DOWNLOAD FROM THE NAVAL AIR TECHNICAL DATA AND ENGINEERING SERVICE
 COMMAND (NATEC) WEBSITE AT [HTTPS://WWW.NATEC.NAVY.MIL/](https://www.natec.navy.mil/).

ALL IRACS RECEIVED PRIOR TO RECEIPT OF SUBJECT TYPE B IRAC SHALL BE MAINTAINED IN
 APPLICABLE MANUAL IN ACCORDANCE WITH REFERENCE A.

1 OF 2 (Date, Time, Group)
 (Issuing activity)

UUUUUUUUUUUUUUUUUUUUUU
 U UNCLASSIFIED U
 UUUUUUUUUUUUUUUUUUUUU

FIGURE 2. Example of Type B IRAC Release Notification Message.

MIL-DTL-81748E(AS)

INTERIM RAPID ACTION CHANGE

Date: (Day Month Year)

Category: (Priority or Urgent)

From: (Issuing Activity)

To: F/A-18A ADRL for A1-F18AC-XXX-XXX

Subj: INTERIM RAPID ACTION CHANGE NO (IRAC number) TO TECHNICAL MANUAL (NAVAIR number and title) OF (date of issue, change number and date as applicable).

References: (as required)

Encl: (1) Example: WP 021, pages 5 and 6

Point of Contact:

A. The name, title, phone number, email address, activity name, office code

1. Purpose of Change: Example: TO CORRECT/PREVENT (cite condition based on Section 3.1) Hazard to Safety of Personnel condition by providing new procedure, which eliminates the potential hazard.

2. Detailed Information:

a. Pen and ink changes to the technical content of a manual are not authorized. The following technical content change information applies to the referenced pages, paragraphs, and figures of the subject manual until formal update is released.

b. Instructions for incorporating enclosures.

3. Validated by: Provide activity name, activity code, and POC name and telephone number.

FIGURE 3. Example of Type B IRAC cover letter.

4. Related Instructions:

- a. For IRACs affecting manuals in paper copy – Maintain this IRAC with the applicable manual by placing or attaching the cover letter directly behind the title page. Mark the specific change area in the margin of each page affected and annotate the changed page or card listed on the A Page with a vertical line and the IRAC number. Replacement page(s) shall be inserted as directed in paragraph 2.b. This Type B IRAC shall not be removed until receipt of the formal update.
- b. For IRACs affecting manuals on CD-ROM – affix an adhesive label to the CD-ROM case annotated with the applicable publication number and IRAC number. The label should be positioned to allow for additional IRACs as they occur and should not cover the date or CD title. Maintain the IRAC on file until receipt of the superseding CD-ROM.
- c. Subject IRAC shall be incorporated into applicable manual no later than 12 months after IRAC issue date (or next formal change) by (insert activity name and code).

By Direction
I. B. IRAC

FIGURE 3. Example of Type B IRAC cover letter - Continued.

MIL-DTL-81748E(AS)

A1-HXXAD-123-000
IRAC 5 - 15 September 2004

FIG 010 00
Page 3 of 4

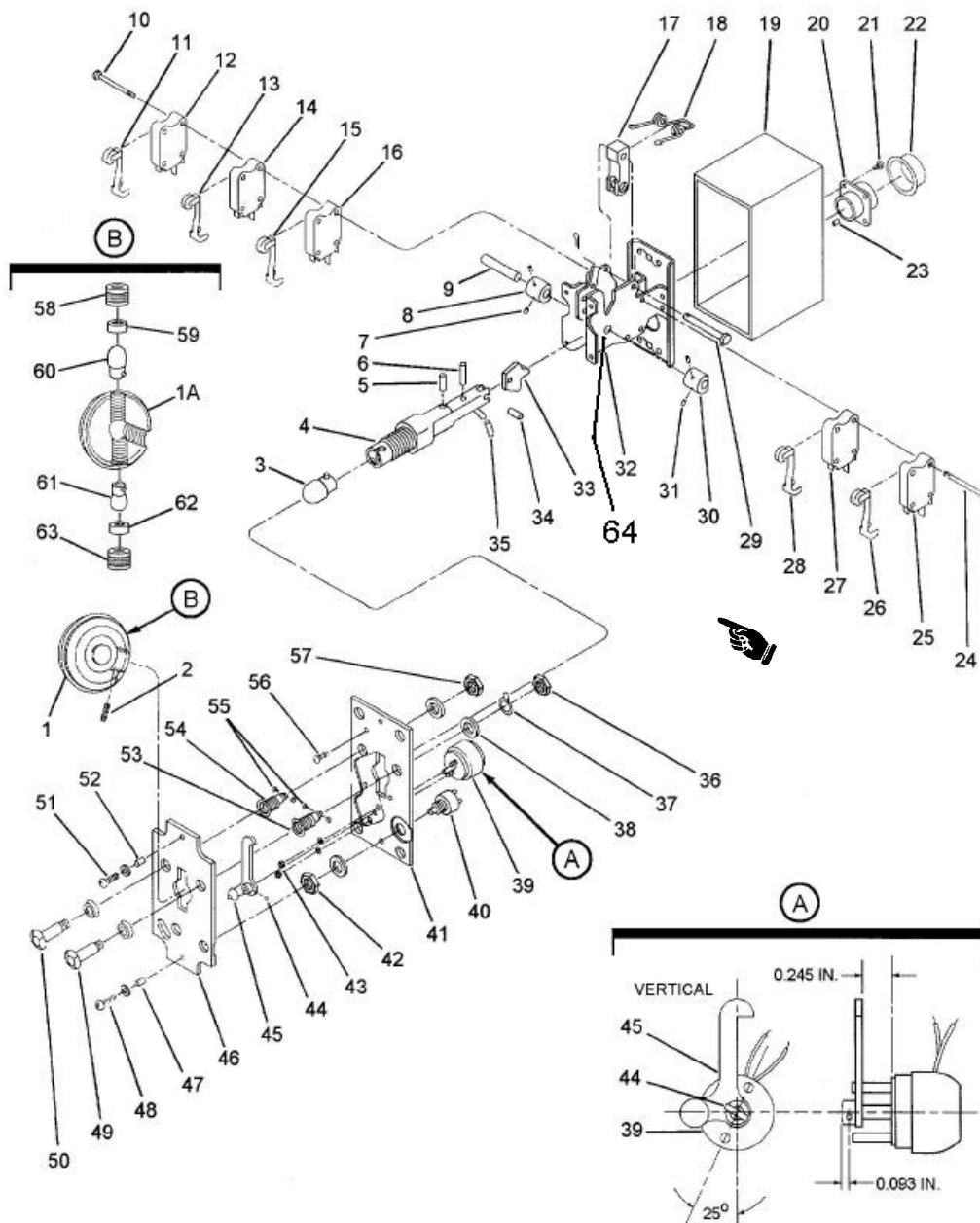

Figure 1. Landing Gear Control Panel - Disassembly/Assembly

FIGURE 4. Example of Type B IRAC replacement page.

MIL-DTL-81748E(AS)

NAVAIR 01-XXXXX-75

TECHNICAL MANUAL

AIRBORNE WEAPONS/STORES LOADING MANUAL

NAVY MODELS X-XX, X-XX AND XX-XX AIRCRAFT

IRAC HAS NOT BEEN ISSUED PRIOR TO THIS RAC

DISTRIBUTION STATEMENT C. Distribution authorized to U.S. Government agencies and their contractors to protect publications required for official use or for administrative or operational purposes determined on 1 February 1993. Other requests for this document shall be referred to Commanding Officer, Naval Air Technical Data and Engineering Service Command, Bldg 90, P O Box 357031, San Diego, CA 92135-7031.

DESTRUCTION NOTICE - For unclassified, limited documents, destroy by any method that will prevent disclosure of contents or reconstruction of the document.

PUBLISHED BY DIRECTION OF THE COMMANDER, NAVAL AIR SYSTEMS COMMAND

15 NOVEMBER 1991
RAPID ACTION CHANGE 4 - 1 APRIL 1995

FIGURE 5. Example of RAC title page.

MIL-DTL-81748E(AS)

NAVAIR 01-XXXXX-75

LIST OF EFFECTIVE PAGES

Insert latest changed pages; dispose of superseded pages in accordance with applicable regulations.

NOTE: On a changed page, the portion of the text affected by the latest change is indicated by a vertical line, or other change symbol, in the outer margin of the page. Changes to illustrations are indicated by miniature pointing hands. Changes to wiring diagrams are indicated by shaded areas.

Dates of issue for original and changed pages are:

Original 0.....15 Nov 91	RAC 3.....15 Aug 92
RAC 1.....15 Apr 92	Change 1.....1 Apr 95
RAC 2.....15 May 92	RAC 4.....1 Apr 95

Total number of pages in this manual is 570 consisting of the following:

Page#	Change
No.	No.
Title.....	RAC 4
A.....	RAC 4
i - xxii.....	0
1-1 - 1-23.....	0
1-24 Blank.....	0
2-25 - 2-79.....	1
2-80 - 2-81.....	0
2-82.....	1
2-83 - 2-168.....	RAC 3
3-1 - 3-30.....	0
4-1 - 4-12.....	RAC 2
4-13 - 4-61.....	0
4-62 - 4-99.....	1
4-100 - 4-109.....	0
5-1 - 5-20.....	0
5-21.....	RAC 4
5-22.....	RAC 1
5-23 - 5-25.....	0
5-26 - 5-44.....	0
Glossary 1 - Glossary 5.....	0
Index 1 - Index 5.....	0

Zero in this column indicates an original page.

A RAC 4

FIGURE 6. Example of a RAC list of effective pages.

MIL-DTL-81748E(AS)

A1 - F 18AC-XXX-XXX

RAPID ACTION CHANGE 6 - 1 SEPTEMBER 1994

Page A

NUMERICAL INDEX OF EFFECTIVE WORK PACKAGES/PAGES

List of Current Changes

Original 0	1 Feb 2001 Incl	IRAC 5	Cancelled (never issued)
	previously Inc. IRACs 1 through 3	Change 3	1 Jun 03
Change 1	1 May 02	RAC 6	1 Sep 04
Change 2.....	30 Nov 02 (IRAC 4 Inc)		

Only those work packages/pages assigned to the manual are listed in this index. Insert Rapid Action Change 4 dated 1 September 1994. Dispose of superseded and deleted work packages/pages. Superseded and deleted work packages/pages shall be destroyed in accordance with applicable regulations. If changed pages are issued to a work package, insert the changed pages in the applicable work package. The portion of the text affected in a changed or revised work package is indicated by change bars or the change symbol "R" in the outer margin of each column of text. Changes to illustrations are indicated by pointing hands or change bars, as applicable.

WP

Number

Title

Title

Page A Numerical Index of Effective Work Packages

001 00 Alphabetical Index

002 00 Introduction

003 00 Testing

003 00 Component Locator

004 00 Troubleshooting - Maintenance Codes

005 00 Troubleshooting - Air Data Computer CP-1334/A

006 00 Troubleshooting - Angle of Attack

007 00 Troubleshooting - Total Temperature Probe and Air Stream Direction
Sensing Unit Heaters

Total number of pages in this manual is 351 consisting of the following:

WP/Page No.	Change No.	WP/Page No.
Title	RAC 6	1 Blank
A	RAC 6	2-6.....
B	RAC 6	002 00.....
C Blank	RAC 6	1-21
001 00	1	22-26

FIGURE 7. Example of a RAC numerical index of affected work packages/pages

MIL-DTL-81748E(AS)

NAVAIR 19-600-XXX-6-2

**TECHNICAL MANUAL
PERIODIC MAINTENANCE REQUIREMENTS CARDS
NOMENCLATURE
TYPE EQUIPMENT CODE**

DISTRIBUTION STATEMENT C. Distribution authorized to U.S. Government agencies and their contractors to protect publications required for official use or for administrative or operational purposes determined on 1 January 1992. Other requests for this document shall be referred to Commanding Officer, Naval Air Technical Data and Engineering Service Command, Naval Air Station North Island, P.O. Box 357031, Building 90 Distribution, San Diego, CA 92135-7031.

DESTRUCTION NOTICE - For unclassified, limited documents, destroy by any method that will prevent disclosure of contents or reconstruction of the document.

PUBLISHED BY DIRECTION OF THE COMMANDER. NAVAL AIR SYSTEMS COMMAND

1 JANUARY 1998
RAPID ACTION CHANGE 3-1 JUNE 2004

NAVAIR 19-600-XXX-6-2

LIST OF EFFECTIVE CARDS

Insert latest changed cards. Dispose of superseded cards in accordance with applicable regulations.

NOTE: That portion of text affected by the change is indicated by a vertical fine or other change symbol in the outer margin of the card.

Dates of issue for original and changed cards

Original..... 1 Jan 98 (incl. IRACs 1 and 2)	Change 2 5 APR 03
Change 1 1 JUN 02	RAC 3 1 JUN 04

The total number of card faces in this manual is 83 consisting of the following:

CARD NO. CHANGE NO.	CARD NO. CHANGE NO.	CARD NO. CHANGE NO.
Title RAC3	iv 2	1.2 RAC3
A RAC3	v 2	1.3 Blank RAC3
B RAC3	vi 1	2 RAC3
C RAC3	vii 2	2.1 RAC3
i 1	viii 2	2.2 RAC3
ii 2	1 2	3..... 2
iii 1	1.1 0	3.1 RAC3

A RAPID ACTION CHANGE 3

FIGURE 8. Example of title and "A" cards of changed periodic maintenance requirement manual.

MIL-DTL-81748E(AS)

CONCLUDING MATERIAL

Custodian:
Navy-AS

Preparing activity:
Navy-AS
(Project No. TMSS-N257)

NOTE: The activity listed above was interested in this document as of the date of this document. Since organizations and responsibilities can change, you should verify the currency of the information above using the ASSIST Online database at <http://assist.daps.dla.mil/>