

INCH-POUND

MIL-DTL-6615G
w/AMENDMENT 1
1 September 2011
SUPERSEDING
MIL-DTL-6615G
5 February 2008

DETAIL SPECIFICATION

HOSE ASSEMBLIES, RUBBER, FUEL AND NONPOTABLE WATER,
WITH REATTACHABLE COUPLINGS, LOW TEMPERATURE,
GENERAL SPECIFICATION FOR

This specification is approved for use by all Departments
and Agencies of the Department of Defense.

1. SCOPE

1.1 Scope. This specification covers requirements for hose assemblies, rubber, fuel and nonpotable water, with reattachable couplings, low temperature. The hose assemblies covered in this specification are for two types of rubber hose assemblies used with fuel or nonpotable demineralized water.

1.2 Part or Identifying Number (PIN). The PIN consists of the letter M, the basic specification number, a dash, a letter I or II for type, a dash, two numbers for length in feet, length in inches, and a letter for hose assembly configuration.

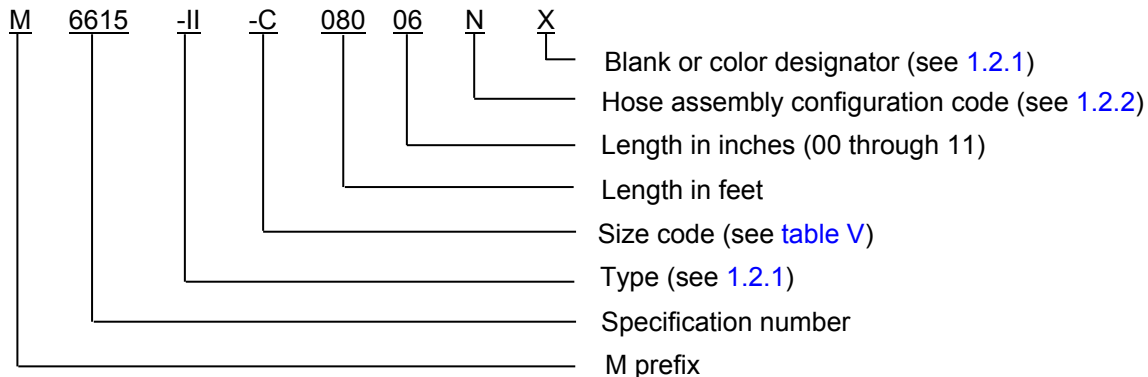

PIN examples:

Hose: M6615-II-C25000, indicates a hose, type II, 2 inch inside diameter (ID), 250 feet long.

Hose assembly: M6615-II-C08006N, indicates a hose assembly, type II, 2 inch inside diameter (ID), 80 feet 6 inches long, SAE-AS38404 class I, type I couplings on both ends.

Comments, suggestions, or questions on this document should be addressed to: DLA Land and Maritime, Columbus, Attn: VAI, P.O. Box 3990, Columbus, OH 43218-3990, or emailed to Fluidflow@dla.mil. Since contact information can change, you may want to verify the currency of this address information using the ASSIST Online database at <https://assist.daps.dla.mil>.

MIL-DTL-6615G
w/AMENDMENT 1

1.2.1 Types. Hose assemblies are furnished in the following types:

Type I - With electrical bonding (see 3.3.1.4).

Type II - Without electrical bonding.

1.2.2 Hose assembly configuration. The hose coupling specification, class, type and code letter are specified in tables I, II and III. Figures 1, 2, and 3 show typical hose end coupling configurations.

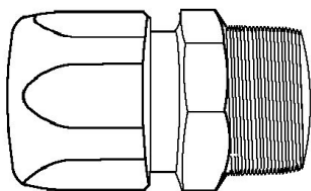

Type I

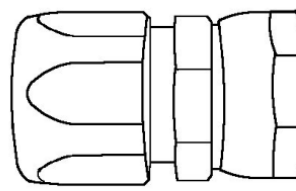

Type II

FIGURE 1. Couplings SAE-AS38404.

TABLE I. SAE-AS38404 Hose assembly configuration.

Hose assembly configuration code letter	Coupling, SAE-AS38404 class 1 or 2, type I or II ^{1/}							
	End 1				End 2			
	Class type I	Class 1 type II	Class 2 type I	Class 2 type II	Class 1 type I	Class 1 type II	Class 2 type I	Class 2 type II
N	X				X			
P		X				X		
R			X				X	
S				X				X
T	X					X		
V			X					X

^{1/} Types and classes are defined as specified in SAE-AS38404 couplings:

Type I - External NPT thread

Type II - External NPSH thread with swivel.

Class 1 - Fuel service (brass body).

Class 2 - Dematerialized water service (stainless steel body).

MIL-DTL-6615G
w/AMENDMENT 1

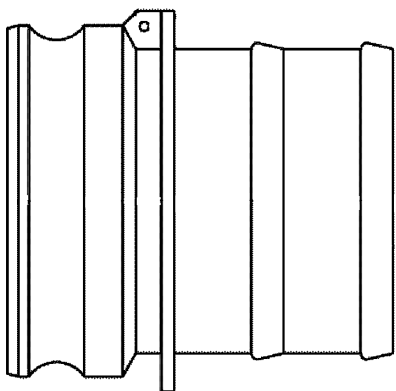

A-A-59326/2 (type II).

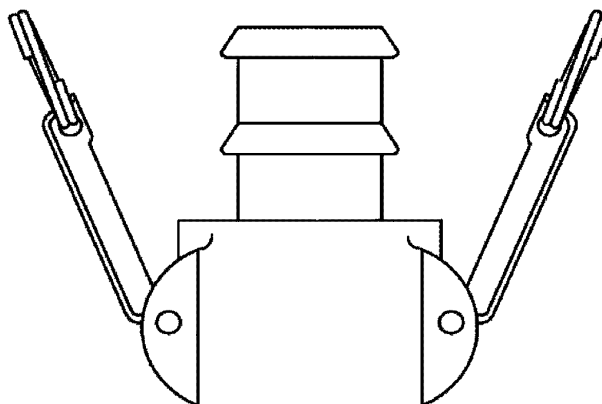

A-A 59326/6 type VI

FIGURE 2. Male and female hose shanks.

TABLE II. Male and female hose shanks.

Hose assembly configuration code letter	Coupling					
	End 1			End 2		
	A-A-59326/2 <u>1/</u> Class 1 type II	A-A-59326/6 <u>2/</u> Class 1 Style 2	A-A-59326/6 Class 1 Style 1	A-A-59326/2 <u>1/</u> Class 1 type II	A-A-59326/6 Class 1 Style 2	A-A-59326/6 Class 1 Style 1
W	X			X		
X		X			X	
Y	X				X	
A			X			X
B	X					X
C		X				X
Z	No couplings (see 6.2 d)					

1/ A-A-59326/2 is a male hose shank class 1 - aluminum

2/ A-A-59326/6 is a female hose shank class and styles are defined as follows:

Class1 - Aluminum

Style 1 - No positive lock mechanism

Style 2 - Positive lock mechanism.

MIL-DTL-6615G
w/AMENDMENT 1

FIGURE 3. Unisex coupling.

TABLE III. Unisex coupling. 1/ 2/

Hose assembly configuration code letter	Coupling			
	End 1		End 2	
	A-A-59377-A (with valve)	A-A-59377-B (valve less)	A-A-59377-A (with valve)	A-A-59377-B (valve less)
G w/o strainer	X		X	
H w/o strainer		X		X
J w/o strainer	X			X
K with strainer ^{3/}	X		X	
L with strainer ^{3/}		X		X
M with strainer ^{3/}	X			X

^{1/} Caps for sealing coupling ends to be provided.

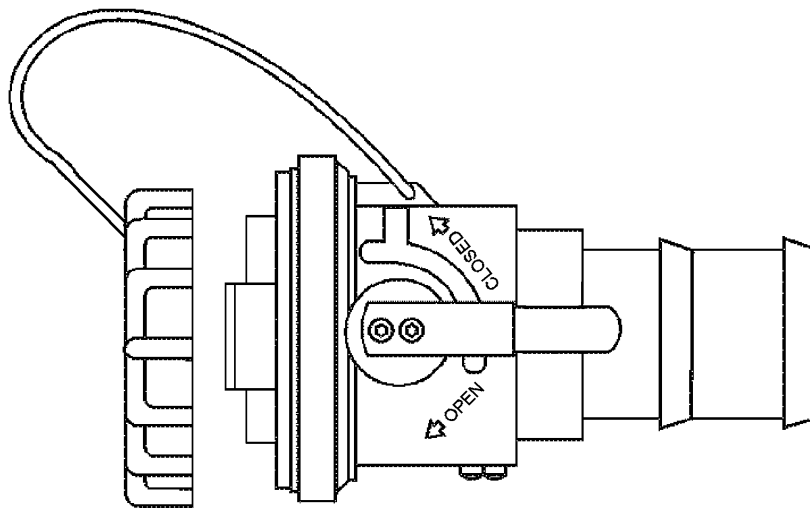
^{2/} For 2 or 3 inch hoses only.

^{3/} A-A-59377 unisex coupling with 40 to 60 mesh strainer.

1.2.3 Unisex coupling paint colors. Paint is in accordance with 3.3.5.3, color designators are listed in table IV.

TABLE IV. Unisex coupling color designators.

Color designator	Color	Exceptions
Blank	Non-vivid and lusterless shade of tan	Valve lever, bumper and dust cap are a lusterless shade of black
A	FED-STD-595/24052 (semi-gloss green)	None
B	FED-STD-595/33446 (desert tan)	None
C	FED-STD-595/16081 (dark gray)	None
D	FED-STD-595/15044 (dark blue)	None

MIL-DTL-6615G
w/AMENDMENT 1

2. APPLICABLE DOCUMENTS

2.1 General. The documents listed in this section are specified in sections 3, 4, or 5 of this specification. This section does not include documents cited in other sections of this specification or recommended for additional information or as examples. While every effort has been made to ensure the completeness of this list, document users are cautioned that they must meet all specified requirements documents cited in sections 3, 4, or 5, of this specification, whether or not they are listed.

2.2 Government documents.

2.2.1 Specifications, standards, and handbooks. The following specifications, standards, and handbooks form a part of this document to the extent specified herein. Unless otherwise specified, the issues of these documents are those cited in the solicitation or contract.

FEDERAL STANDARDS

- FED-STD-595/15044 - Blue, Gloss
- FED-STD-595/16081 - Gray, Gloss
- FED-STD-595/24052 - Green, Semigloss
- FED-STD-595/33446 - Yellow, Flat or Lusterless

COMMERCIAL ITEM DESCRIPTIONS

- A-A-59326/2 - Coupling Half, Male by Hose Shank, Type II
- A-A-59326/6 - Coupling Half, Female by Hose Shank, Type VI
- A-A-59326/10 - Coupling Half, Cap, Dust, Type IX
- A-A-59326/11 - Coupling Half, Plug, Dust, Type X
- A-A-59377 - Coupling Assembly, Quick-Disconnect, Sexless Type

DEPARTMENT OF DEFENSE SPECIFICATIONS

- MIL-DTL-5624 - Turbine Fuel, Aviation, Grades JP-4 and JP-5
- MIL-DTL-83133 - Turbine Fuels, Aviation, Kerosene Types, NATO F-34 (JP-8), and NATO F-35, and JP-8+100
- MIL-DTL-83420 - Wire Rope, Flexible, For Aircraft Control, General Specification For
- MIL-PRF-16173 - Corrosion Preventive Compound, Solvent Cutback, Cold-Application.
- MIL-PRF-24635 - Coating Systems, Weather-Resistant, Exterior Use
- MIL-PRF-85285 - Coating: Polyurethane, Aircraft and Support Equipment
- MIL-PRF-85582 - Primer Coatings: Epoxy, Waterborne

(Copies of these documents are available online <https://assist.daps.dla.mil> or from the Standardization Document Order Desk, 700 Robbins Avenue, Building 4D, Philadelphia, PA 19111-5094.)

2.3 Non-Government publications. The following documents form a part of this document to the extent specified herein. Unless otherwise specified, the issues of these documents are those cited in the solicitation or contract.

MIL-DTL-6615G
w/AMENDMENT 1

ASTM INTERNATIONAL

ASTM D156	-	Saybolt Color of Petroleum Products (Saybolt Chronometer Method).
ASTM D380	-	Standard Test Methods for Rubber Hose
ASTM D412	-	Rubber and Thermoplastic Rubbers Vulcanized and Thermoplastic Elastomers - Tension
ASTM D471	-	Standard Test Method for Rubber Property Effect of Liquids
ASTM D2276	-	Standard Test Method for Particulate Contaminant in Aviation Fuel by Line Sampling

(Copies of these documents are available online at <http://www.astm.org> or from the ASTM International, P.O. Box C700, 100 Barr Harbor Drive, West Conshohocken, PA 19428-2959.)

SAE INTERNATIONAL

SAE-AS1933	-	Age Controls for Hose Containing Age-Sensitive Elastomeric Material
SAE-AS38404	-	Couplings, Hose, Reattachable Screw-On.

(Copies of these documents are available from SAE International, 400 Commonwealth Drive, Warrendale, PA 15096-0001, Tel: 877-606-7323 (inside USA and Canada) or 724-776-4970 (outside USA), www.sae.org.)

2.4 Order of precedence. Unless otherwise noted herein or in the contract, in the event of a conflict between the text of this document and the references cited herein the text of this document takes precedence. Nothing in this document, however, supersedes applicable laws and regulations unless a specific exemption has been obtained.

3. REQUIREMENTS

3.1 First article. When specified (see 6.2), samples shall be subjected to first article inspection in accordance with 4.5.

3.2 Materials. Materials shall be as specified herein and shall conform to all applicable specifications and drawings. When a definite material is not specified, a material shall be used which will enable the hose or hose assembly to meet the requirements of this specification. Acceptance or approval of any constituent material shall not be construed as a guarantee of acceptance of the finished product.

3.2.1 Recycled, recovered, or environmentally preferable materials. Recycled, recovered, or environmentally preferable materials shall be used to the maximum extent possible, provided that the material meets or exceeds the operational and maintenance requirements, and promotes economically advantageous life-cycle costs.

3.2.1.1 Used or rebuilt components . The use of used or rebuilt components shall not be allowed.

3.3 Design and construction.

3.3.1 Hose. The hose shall consist of an inner tube; braided, loomed, or plied reinforcement and a protective outer cover, see figure 4. Type I hose shall have spirally wound electrical bonding wires, see 3.3.1.4. The ends of the hose shall not be shaved, tapered or have the inner or outer diameter changed in any way, to facilitate attachment of the couplings.

MIL-DTL-6615G
w/AMENDMENT 1

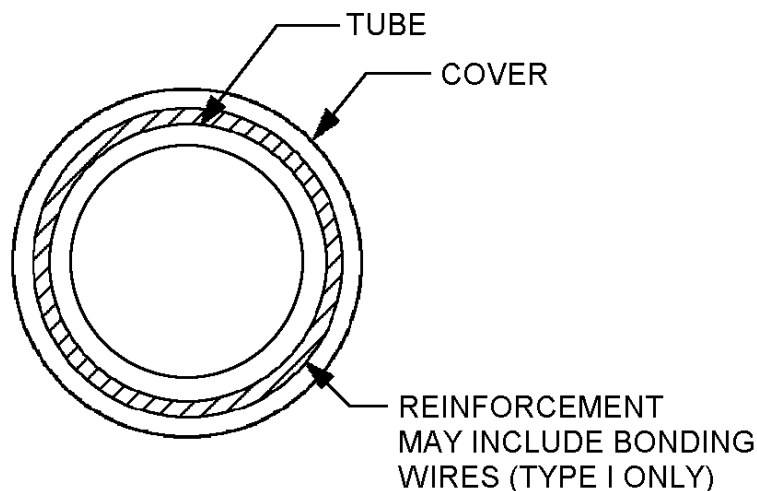

FIGURE 4. Hose construction.

3.3.1.1 Inner tube. The inner tube shall be a high aromatic aviation fuel-resistant (JP-4, JP-5, and JP-8) synthetic rubber compound that meets the requirements of this specification. The bore of the inner tube shall be smooth, free from pitting, objectionable cuttings, borings, or cements; and shall have a uniform wall thickness not less than 1/16 inch. The materials used for the tube and the resultant hose shall not produce or cause an increase in sediment contamination to the fuel flowing through it or the fuel stored in it for extended periods. Fuel stored in the hose for extended periods shall not experience a change in color due to the hose tube.

3.3.1.2 Reinforcement. The reinforcement shall be well, evenly, and firmly braided, loomed, or plied, and free from defects, dirt, knots, lumps, and irregularities of twist.

3.3.1.3 Cover. The cover shall be constructed of polychloroprene rubber compounded to meet the requirements of this specification. The cover shall be smooth, free from pitting, and of uniform thickness of not less than 1/16 inch.

3.3.1.4 Electrical bonding (for type I only). Spirally wound electrical bonding wires, see 3.3.1.4.1, shall be either included in one of the braids or built in between the reinforcements in such a way as to form an angle of not less than 45 degrees with the longitudinal axis of the hose. The hose shall not react chemically with the wires or develop kinks when the hose is subjected to the burst resistance test specified in 4.4.10. The wires shall be bonded to the coupling either by pulling them out so that not less than 1/2 inch of each wire is in intimate contact with the coupling, or by driving one leg of a wire staple into the bonding cable so that the other leg of the staple is outside the hose and inside the coupling.

3.3.1.4.1 Electrical bonding wires. The electrical bonding wires shall be stainless steel or tin-coated copper. The electrical bonding wires may be either braided or stranded, but shall have a cross sectional area equivalent to the following:

Stranded - 7 strands 31 AWG
Braided - 48 strands 36 AWG

MIL-DTL-6615G
w/AMENDMENT 1

3.3.2 Hose size and weight. The hose shall be furnished in the sizes and weights specified in table V.

TABLE V. Hose dimensions and weights. 1/ 2/

Size code	ID inch (mm)	OD (inches \pm .0625) inch (mm)	Weight of hose (maximum lb./ft.) (kg/0.30 m)
A	1.250 \pm .0625 (31.75 \pm 1.588)	1.875 (47.63)	1.25 (0.57)
B	1.5000 \pm .0313 (38.10 \pm 0.795)	2.047 (51.99)	1.38 (0.63)
C	2.000 \pm .0313 (50.80 \pm 0.795.)	2.563 (65.10)	1.75 (0.79)
D	2.500 \pm .0313 (63.50 \pm 0.795)	3.063 (77.80)	2.25 (1.02)
E	3.000 \pm .0313 (76.20 \pm 0.795)	3.594 (91.29)	2.70 (1.22)
F	4.000 \pm .0625 (101.60 \pm 1.588)	4.625 (117.48)	4.00 (1.81)

1/ Dimensions are in inches.

2/ Metric equivalents are given for information only.

3.3.3 Length. The length of the hose shall be as shown on figure 5. The length measurement shall not include the couplings.

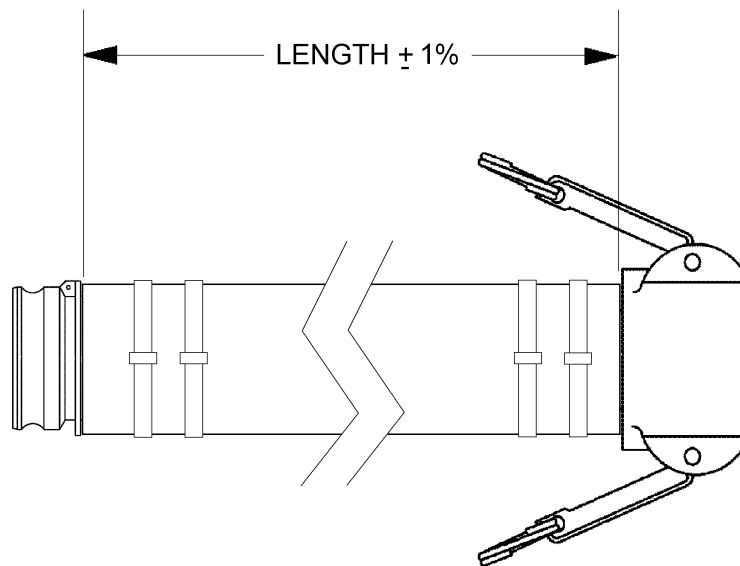
FIGURE 5. Hose assembly length.

3.3.4 Weight. The maximum weight of the hose per foot without couplings shall not exceed the values specified in table V.

MIL-DTL-6615G
w/AMENDMENT 1

3.3.5 Hose assembly. A complete hose assembly shall consist of the hose, two reattachable couplings (one attached to each end of the hose), reusable protective caps or plugs (one on each coupling), and hose clamps, when applicable.

3.3.5.1 Couplings. Couplings on the ends of the hose shall be in accordance with SAE-AS38404 class 1 or 2, type I or II (see [table I](#)), A-A-59326/2 class 1, type II, or A-A-59326/6, class 1, style 2 (see [table II](#)), or A-A-59377.

3.3.5.2 Hose clamps. Hose clamps shall be provided with each A-A-59326/2 and A-A-59326/6 coupling. The bands and buckles shall be of corrosion-resistant steel 300 series, .750 inch (19.05 mm) wide for 4 inch (10.16 cm) inside diameter hose and not less than .500 inch (12.70) wide bands for smaller inside diameter hoses.

3.3.5.3 Unisex coupling top coat. Unless otherwise specified, see [1.2.3](#), the coupling assembly color is a non-vivid and lusterless shade of tan, except the valve lever, bumper and dust cap, if supplied, are a lusterless shade of black. If required all exposed metal surfaces shall be coated with either primer/topcoat in accordance with MIL-PRF-85582, type I, class N, MIL-PRF-85285, type II or III, class H or MIL-PRF-24635, type III or IV, class 2 or 3, grade A.. The colors shall be in accordance with FED-STD-595/15044, FED-STD-595/16081, FED-STD-595/24052, or FED-STD-595/33446, see [1.2.1](#).

3.4 Performance.

3.4.1 Examination of product. The hose assembly shall conform to the requirements of this specification when visually examined as specified in [4.7.1](#).

3.4.2 Rubber compound performance inspection.

3.4.2.1 Adhesion. When tested as specified in [4.7.2.1](#), the adhesion between component parts for unaged hose shall be a minimum of 12 pounds per inch for sizes up to and including the 3-inch ID hose, and a minimum of 10 pounds per inch for the 4-inch ID hose. The adhesion for hose aged in accordance with [4.7.2.1](#) shall be a minimum of 9 pounds per inch for sizes up to and including the 3-inch ID size and a minimum of 5 pounds per inch for the 4-inch ID size.

3.4.2.2 Tensile strength. When tested as specified in [4.7.2.2](#), the tensile strength of the tube and cover after a 48-hour immersion in the specified hydrocarbon fluid at $75^{\circ} \pm 5^{\circ}\text{F}$ ($23.9^{\circ}\text{C} \pm 2.8^{\circ}\text{C}$) shall not be less than 600 psi and 400 psi (4.1 MPa and 2.8 MPa), respectively.

3.4.2.3 Ultimate elongation. When tested as specified in [4.7.2.2](#), the ultimate elongation of the tube and cover shall not be less than 200 percent. After a 48-hour immersion in the specified hydrocarbon fluid at $75^{\circ} \pm 5^{\circ}\text{F}$ ($23.9^{\circ}\text{C} \pm 2.8^{\circ}\text{C}$), the ultimate elongation of the tube and cover shall be not less than 100 percent.

3.4.2.4 Low temperature bend. When tested as specified in [4.7.2.3](#), specimens of the tube and cover shall not crack when bent into a concave shape and maintained in this shape for not less than 72 hours at a temperature of $-67^{\circ} \pm 2^{\circ}\text{F}$ ($-55^{\circ}\text{C} \pm 1.1^{\circ}\text{C}$), nor shall they crack upon sudden further bending into a U-shape.

3.4.2.5 Volume increase. When tested as specified in [4.7.2.4](#), the volume increase of the tube and cover specimens after 24-hour immersion in the specified hydrocarbon fluid at $75^{\circ} \pm 5^{\circ}\text{F}$ ($23.9^{\circ}\text{C} \pm 2.8^{\circ}\text{C}$) shall not exceed 50 and 100 percent, respectively.

MIL-DTL-6615G
w/AMENDMENT 13.4.3 Hose assembly performance inspection.

3.4.3.1 Proof pressure. When tested as specified in 4.7.3.1, the hose, with couplings attached, shall not leak or show imperfections in either the hose or couplings when subjected to the hydrostatic pressure specified in table IV for not less than 30 seconds.

3.4.3.2 Elongation and contraction. When tested as specified in 4.7.3.2, the length of the hose shall not change more than 7 percent during subjection to the proof pressure test.

3.4.3.3 Electrical bonding (type I only). When tested as specified in 4.7.3.3, the hose, with couplings attached shall show no break in the continuity between the couplings and the bonding.

3.4.3.4 Pull resistance. When tested as specified in 4.7.3.4, the coupling shall not pull off the hose upon subjection to a pull of 1,000 pounds (453.6 kg) directed along the longitudinal axis.

3.4.3.5 Burst. When tested as specified in 4.7.3.5, the hose shall not burst or develop a permanent blister when subjected to the hydrostatic pressure specified in table VI.

TABLE VI. Hose pressure.

Requirement	ID (inches)					
	1.250	1.500	2.000	2.500	3.000	4.000
Operating pressure psi (MPa)	200 (1.4)	200 (1.4)	175 (1.2)	175 (1.2)	150 (1.0)	125 (0.9)
Burst resistance min. psi (MPa)	800 (5.5)	800 (5.5)	700 (4.8)	700 (4.8)	600 (4.1)	500 (3.4)
Proof pressure min. psi (MPa)	300 (2.0)	300 (2.0)	275 (1.9)	275 (1.9)	250 (1.7)	250 (1.7)

3.4.3.6 Inner tube electrical resistance. When tested as specified in 4.7.3.6, the electrical resistance of the tube shall be within 10^3 ohms per meter to 10^6 ohms per meter.

3.4.3.7 Low temperature flexibility. When tested as specified in 4.7.3.7, the hose shall not crack when tied in a U-shape and subjected to a temperature of $-67^{\circ} \pm 2^{\circ} \text{F}$ ($-55^{\circ} \text{C} \pm 1.1^{\circ} \text{C}$) for at least 72 hours. After such conditioning, the 1-1/4 to 2-1/2 inch size hoses, inclusive, shall not require a force of more than 70 pounds (31.8 kg) to straighten to an approximate 90-degree angle within 1 minute, and the 3 and 4 inch sizes shall not require a force of more than 80 pounds (36.3 kg) to straighten to an approximate 180-degree angle within 1 minute. No cracks shall develop during this straightening.

3.4.3.8 Sediment contamination and color change. When tested as specified in 4.7.3.8, the hose shall not contribute to the occurrence of in-line sedimentation or fuel discoloration whenever jet fuel is stationary in the hose.

3.5 Cleanliness. All hose assemblies shall be free from oil, grease, dirt, moisture, cleaning solvents and other foreign material, both internally and externally. Hose and hose assemblies shall be provided with protective caps in 3.5.1, 3.5.2, or 3.5.3.

3.5.1 Hose without couplings. Hose shall be provided without couplings, but with adequate caps or seals to prevent the entrance of foreign contaminants (see 6.2).

MIL-DTL-6615G
w/AMENDMENT 1

3.5.2 Coupling caps. Male couplings in accordance with SAE-AS38404 shall be provided with a protective, closed end, reusable, threaded metal cap having a thickness of .022 to .031 inch (0.56 to 0.79 mm) or a reusable plastic cap of suitable thickness and composition that will not be chemically affected by grade 1 corrosion-preventive compound in accordance with MIL-PRF-16173. Male couplings in accordance with to A-A-59326/2 shall be provided with, A-A-59326/10 dust caps, except a MIL-DTL-83420, .063-inch (1.60 mm) diameter cable with a clear nylon jacket may be used in lieu of the sash chain.

3.5.3 Coupling plugs. Female couplings conforming to SAE-AS38404 shall be provided with a protective, closed, reusable, threaded metal or plastic plug of suitable thickness and composition that will not be chemically affected by grade 1 corrosion-preventive compound in accordance with MIL-PRF-16173. Female couplings in accordance with A-A-59326/6 shall be provided with dust plugs in accordance with A-A-59326/11 except MIL-DTL-83420, .063-inch (1.60 mm) diameter cable with a clear nylon jacket may be used in lieu of the sash chain.

3.6 Age limit. The age limit of bulk hose and hose assemblies covered by this specification and furnished for use by the Government shall not exceed the limits specified in SAE-AS1933. Hose inner tubing used in the hose assemblies shall have been manufactured not more than two quarters prior to presentation for acceptance, see 4.7.1.

3.7 Identification of product. The hose shall be legibly marked along its longitudinal axis with a yellow fuel-resistant stripe. The stripe shall be broken at intervals of approximately 2 inches.

3.7.1 Hose labeling. A continuous color optional mylar tape layline shall be cured into the hose during manufacturing process. The marking, in the minimum of 12 inch (305 mm) increments, shall include all the information in 3.7.1 a, b, c, and d. The letters shall be legible and a contrasting color to the mylar tape. The tape shall run longitudinal along the hose and the print information shall be repeated continuously along the length of the hose.

- a. PIN as described in 1.2, length, configuration, and color designator and may be omitted.
- b. Cure date in quarter and year such as 4Q11 for fourth quarter 2011.
- c. CAGE code.
- d. Manufacturer's name or trademark.

Example: M6615-II-C 4Q11 CAGE manufacturers name or trademark.

3.7.2 Tagging of hose assemblies. After the hose is assembled into a hose assembly the hose assembler shall attach a removable tag to each hose assembly. The marking shall include all the information in 3.7.2 a, b, c, and d and shall contain the military PIN, date of assembly and specification number and name or CAGE code of assembly manufacturer.

- a. PIN as described in 1.2.
- b. Assembly date in quarter and year such as 4Q11 for fourth quarter 2011.
- c. CAGE code.
- d. Manufacturer's name or trademark.

Example: M6615-II-C08006N 4Q11 CAGE manufacturers name or trademark.

3.8 Workmanship. Workmanship shall be of the quality necessary to produce hose assemblies free from defects which would adversely affect service performance, see table VII.

MIL-DTL-6615G
w/AMENDMENT 1TABLE VII. Workmanship defects.

Inspection	Paragraph
Hose ends of the hose shaved or tapered	3.3.1
Inner tube missing; braided, loomed, or plied reinforcement	3.3.1.1
Inner tube bore shall be smooth, free from pitting, objectionable cuttings, borings, or cements; and shall have a uniform	3.3.1.1
Inner tube wall thickness not less than 1/16 inch	3.3.1.1
Reinforcement shall be well, evenly, and firmly braided, loomed, or plied, and free from defects, dirt, knots, lumps, and irregularities of twist	3.3.1.2
Cover shall be smooth, free from pitting.	3.3.1.3
Reinforcement through cover	N/A
Cover uniform thickness not less than 1/16 inch	3.3.1.3
Type I hose missing spirally wound electrical bonding wires	3.3.1.4
Electrical bonding wires not stainless steel or tin-coated copper	3.3.1.4.1
Electrical bonding wires wrong AWG size or strands missing	3.3.1.4.1

4. VERIFICATION

4.1 Classification of inspections. The inspection requirements specified herein are classified as follows:

- a. First article inspection (see 4.5).
- b. Conformance inspection (see 4.6).

4.2 Inspection conditions. Unless otherwise specified, all inspections shall be performed in accordance with the test conditions specified in the applicable test method referenced in the test procedures.

4.3 Test equipment and inspection facilities. Test and measuring equipment and inspection facilities of sufficient accuracy, quality and quantity to permit performance of the required inspection shall be used.

4.4 Responsibility for compliance. All items shall meet all requirements of sections 3, 4, and 5. The inspection set forth in this specification shall become a part of the contractor's overall inspection system or quality program. The absence of any inspection requirements in the specification shall not relieve the contractor of the responsibility of ensuring that all products or supplies submitted to the Government for acceptance comply with all requirements of the contract. Sampling inspection, as part of manufacturing operations, is an acceptable practice to ascertain conformance to requirements, however, this does not authorize submission of known defective material, either indicated or actual, nor does it commit the Government to accept defective material. The supplier's inspection and test records shall clearly demonstrate the products conformance to technical specifications.

4.4.1 Lot records. Manufacturers shall keep lot records for 3 years minimum. Manufacturers shall monitor for compliance to the prescribed procedures, and observe that satisfactory manufacturing conditions and records on lots are maintained for these hose assemblies. The records, including as a minimum, an attributes summary of all quality conformance inspections conducted on each lot, shall be available to review by customers at all times.

MIL-DTL-6615G
w/AMENDMENT 1

4.5 First article inspection. First article inspection shall consist of the examinations and tests specified in table VI performed on samples which are representative of the production item, after award of the contract, to determine that the production item meets the requirements of this specification.

4.5.1 Acceptance of first article inspection. Required first article tests at the hose assembly level that were already performed at the bulk hose level may be eliminated from assembly first article testing if documented approval has been obtained from the procuring activity

4.5.2 First article samples. The first article inspection samples shall consist of the following for each size hose specified in the contract or order:

- a. A 10-foot length of uncoupled hose.
- b. A 3-foot (91.44 cm) length of hose with couplings, caps, and plugs attached.
- c. A 15-inch (38.10 cm) length of hose to which couplings have been attached.

4.5.3 First article inspection routine. All samples shall be subjected to first article testing in table VIII. The test sequence shall be determined by the manufacturer unless otherwise specified. Samples shall be identified with the manufacturer's part number and any additional information required by the contract or order.

TABLE VIII. First article inspection.

Inspection	Requirement paragraph	Test paragraph
Rubber compound inspections ^{1/}	---	---
Adhesion	3.4.2.1	4.7.2.1
Tensile strength	3.4.2.2	4.7.2.2
Ultimate elongation	3.4.2.3	4.7.2.2
Low temperature bend	3.4.2.4	4.7.2.3
Volume increase	3.4.2.5	4.7.2.4
Hose and hose assembly inspections	---	---
Examination of product	3.3 , 3.5 , 3.6 , 3.7 , and 3.8	4.7.1
Proof pressure	3.4.3.1	4.7.3.1
Elongation and contraction	3.4.3.2	4.7.3.2
Electrical bonding (for type I only)	3.4.3.3	4.7.3.3
Pull resistance	3.4.3.4	4.7.3.4
Burst	3.4.3.5	4.7.3.5
Inner tube electrical resistance	3.4.3.6	4.7.3.6
Low temperature flexibility	3.4.3.7	4.7.3.7
Sediment contamination and color change	3.4.3.8	4.7.3.8

^{1/} Specimens.

4.5.3.1 Waivers or deviations to specification requirements. All waivers or deviations to specification requirements shall be coordinated through the preparing activity; DLA Land and Maritime, Attn: VAI, P.O. Box 3990, Columbus, OH 43218-3990, or emailed to Fluidflow@dla.mil.

4.5.3.2 Failures. All samples shall meet all of the contract requirements. Failure of a sample unit to pass any test shall be cause for rejection of the entire lot and refusal to grant first article approval.

MIL-DTL-6615G
w/AMENDMENT 1

4.5.4 Disposition of first article samples. Unless otherwise specified, after award of the contract or order, the manufacturer shall forward (1 hose or hose assembly), fabricated from random samples of the hose or hose assembly. The sample shall be representative of the construction, workmanship, components, and materials to be used during production. When a manufacturer is in continuous production of the hose and hose assemblies from one contract to another, submission of additional first article samples for a new contract may be waived at the discretion of the acquiring activity (see 6.2).

4.5.5 First article information. Upon completion of first article inspection, the Government activity responsible for conducting the inspection program (see 6.2), shall report the results of the inspection, with appropriate recommendation, to the contracting officer. Approval of the first article samples or the waiving of first article inspection does not preclude the requirements for performing conformance inspection.

4.5.6 Disposition of samples. First article samples shall be furnished to the Government as directed by the contracting officer (see 6.2).

4.6 Conformance inspection. Conformance inspection shall consist of the examinations and tests specified in tables IX and X performed on individual products or lot samples to determine conformance of the products or lots with the requirements of this specification.

4.6.1 Individual inspections. For manufacturers that have successfully passed first article inspections and are continuously producing hose assemblies to this specification, ongoing inspections shall consist of individual inspections, see table IX. Each production length of hose with couplings attached shall be subjected to the examinations and tests in table IX.

TABLE IX. Individual inspections.

Inspection	Requirement paragraph	Test paragraph	Number of samples
Examination of product	3.3, 3.5, 3.6, 3.7, and 3.8	4.7.1	100%
Proof pressure	3.4.3.1	4.7.3.1	100%
Electrical bonding (for type I only)	3.3.1.4	4.7.3.3	100%
Adhesion ^{1/}	3.4.2.1	4.7.2.1	Specimen

^{1/} Each new lot/batch of bulk hose.

4.6.1.1 Nonconformance individual inspections. If a defect is found in the adhesion between component parts test the lot shall be considered as failed. If a defect is a part of a hose assembly the hose assembly may be reworked. If one or more defects are found in the second inspection lot, the production lot shall be rejected and shall not be supplied to this specification. Test data of part performance shall be made available to the contracting agency upon request.

4.6.2 Sampling and periodic inspection. For manufacturers that have successfully passed first article inspections and are continuously producing hose assemblies to this specification sampling and periodic inspections shall consist of the inspections specified in table X and shall be made on test samples which have been subjected to and passed the individual inspections (see table IX).

MIL-DTL-6615G
w/AMENDMENT 1TABLE X. Sampling and periodic inspections. ^{1/}

Inspections	Requirement paragraph	Inspection paragraph	Sampling	Periodic
Tensile strength and ultimate elongation (specimen)	3.4.2.2, and 3.4.2.3.	4.7.2.2	X	
Volume increase (hose assembly sample)	3.4.2.5	4.7.2.4	X	
Elongation and contraction (Hose sample)	3.4.3.2	4.7.3.2	X	
Sediment contamination and color change	3.4.3.8	4.7.3.8		X
Low temperature flexibility (specimen)	3.4.3.7	4.7.3.7		X
Pull resistance (specimen)	3.4.3.4	4.7.3.4		X
Burst (hose assembly sample)	3.4.3.5	4.7.3.5		X

^{1/} Testing shall be performed in the order specified.

4.6.3 Sampling plan. One hose and coupling assembly from each 5,000 feet or less of the order shall be selected for the sampling tests.

4.6.3.1 Test sample. After the length change test has been conducted on the assembly, the hose shall be cut approximately 3 feet from one end of the assembly and 15 inches from the other to provide lengths for the tests specified in burst (see 4.7.3.5) and pull resistance test (see 4.7.3.4) respectively. One of the couplings in each of these tests shall be the same as assembled in production, except for the coupling halves conforming to A-A-59326/2 or A-A-59326/6. An additional 3 feet of hose shall be cut off the original length for the other sampling tests.

4.6.4 Rejection and retest. A sample hose which fails to meet the individual test requirements of this specification shall be rejected. When a sample or specimen of hose, a hose assembly, or a coupling fails to meet the sampling tests of this specification, the entire lot sampled shall be rejected. Hose which has been rejected shall not be resubmitted for approval without furnishing full particulars concerning the rejection and measures taken to overcome the defects.

4.7 Test Methods

4.7.1 Examination of product. Hose assemblies shall be examined to determine compliance with the requirements of this specification with regards to materials, size, construction, length, cleanliness, weight, couplings, coupling caps and plugs, and when applicable, hose caps or seals (see 3.3), age (see 3.6), marking (see 3.7), and workmanship (see 3.8).

4.7.2 Rubber compound inspections.

4.7.2.1 Adhesion test (see 3.4.2.1). Adhesion testing shall be conducted on ring specimens in accordance with ASTM D380 and shall meet the requirements of 3.4.2.1. The following details shall apply:

- a. 2 hose specimens shall be unaged and 2 hose specimens shall be oil aged.
- b. Specimens to determine adhesion shall be cut from the center of the length.
- c. Fuel aged specimens shall be prepared as specified in (1) and (2) below:
 - (1) Post-immersion adhesion tests shall be conducted on a 12-inch length hose after it has been stopparded with leak proof plugs and filled with fluid in accordance with ASTM D471, reference fuel B at a temperature of 75°F ±5°F for 48 hours.
 - (2) Fuel aged specimens shall be tested within 15 minutes after removal from the fluid.

MIL-DTL-6615G
w/AMENDMENT 1

4.7.2.2 Tensile strength and ultimate elongation test (see 3.4.2.2 and 3.4.2.3.). The tensile strength and ultimate elongation of the tube and cover shall be determined in accordance with ASTM D412 and shall meet the requirements of 3.4.2.2 and 3.4.2.3. The following details shall apply:

- a. A die specified in ASTM D412 shall be used for cutting the specimens.
- b. Ultimate elongation shall be determined on unaged specimens.
- c. Both tensile strength and ultimate elongation shall be determined on specimens aged for 48 hours at $75^{\circ} \pm 5^{\circ}\text{F}$ in fluid in accordance with ASTM D471, reference fuel B.
- d. Tests shall be conducted within 5 minutes after removal from the fluid.

4.7.2.3 Low temperature bend test (see 3.4.2.4). Buffered specimens of the tube and cover shall be subjected to the low temperature bend test and shall meet the requirements of 3.4.2.4. The following details shall apply:

- a. Specimens of the tube and cover shall be 4 inches long and 1/4 inch wide.
- b. The buffered specimens shall be clamped in a concave shape between plates 2-1/2 inches apart and at least 2 inches wide in such a manner that the bend in the test piece does not protrude beyond the edges when the plates are brought together and that the ends are not held for more than 1 1/4 inches.
- c. Exposure the specimens to $-67^{\circ}\text{F} \pm 2^{\circ}\text{F}$ for 72 hours.
- d. The temperatures shall be held at $-67^{\circ} \pm 2^{\circ}\text{F}$ and the plates shall be moved rapidly together until the ends of the specimens are not more than 1 inch apart.
- e. Examine the specimens as detailed in 3.4.3.

4.7.2.4 Volume increase test (see 3.4.2.5). The volume increase of the tube and cover shall be tested in accordance with ASTM D380 and meet the requirements of 3.4.2.5. The hose and tube cover shall be immersion in reference fuel B in accordance with ASTM D471 for 24 hours at $75^{\circ}\text{F} \pm 5^{\circ}\text{F}$ ($23.9^{\circ}\text{C} \pm 2.3^{\circ}\text{C}$).

4.7.3 Hose and hose assembly inspections.

4.7.3.1 Proof pressure test (see 3.4.3.1). Each length of hose with couplings attached shall be tested in accordance with ASTM D380 to proof pressure specified in table VI and shall meet the requirements of 3.4.3.1.

4.7.3.2 Elongation and contraction (see 3.4.3.2). The percentage change in a known length of hose shall be determined in accordance with ASTM D380, while the hose is being subjected to the proof pressure test. The length of hose shall meet the requirement of 3.4.3.2.

4.7.3.3 Electrical bonding test (for type I only) (see 3.4.3.3). Each length of type I hose assemblies with couplings attached shall be electrical resistance tested using a low-voltage ohmmeter. The current path shall be measured between the couplings after it has undergone the proof pressure test and shall meet the requirements or 3.4.3.3.

4.7.3.4 Pull resistance test (see 3.4.3.4). One coupling of the 15-inch hose assembly shall be held securely in a vise while a pull of 1,000 pounds is applied to the other coupling by any convenient means. The rate of jaw separation of the vise shall be 1 inch per minute. The specimen shall meet the requirements of 3.4.7.

4.7.3.5 Burst (see 3.4.3.5). Burst resistance shall be determined in accordance with ASTM D380 and meet the requirements of 3.3.3.5. The couplings used during this test shall be in accordance with SAE-AS38404.

MIL-DTL-6615G
w/AMENDMENT 1

4.7.3.6 Inner tube electrical resistivity test (see 3.4.3.6). The electrical resistance of the tube shall be within 10^3 to 10^6 ohms per meter when measured with a 2% accuracy or better, resistance measuring device. The hose shall be tested in both unpressured and pressured (proof pressure) state. This test may be performed during the proof pressure test, see 4.7.3.1.

4.7.3.7 Low temperature flexibility test (see 3.4.3.7). Hose shall be tested for low temperature flexibility and meet the requirements of 3.4.3.7. Hoses with an ID 1 1/4 through 2 1/2 inch shall be tested in accordance with 4.7.3.7.1, and hose sizes with an ID of 3 and 4 shall be tested in accordance with 4.7.3.7.2.

4.7.3.7.1 Hose ID 1 1/4 through 2 1/2-inch. Low temperature flexibility for hose sizes 1 1/4 inch through 2 1/2 inch shall be tested as follows:

- a. Hoses shall be tested by bending an uncoupled 5-foot length into a U-shape such that the ends of the U are approximately 22 inches apart, tying it in that position, and conditioning the hose for not less than 72 hours at $-67^{\circ} \pm 2^{\circ}\text{F}$.
- b. One arm of the U shall then be held or clamped firmly to a rigid vertical support, and a slow, steady perpendicular pull applied to the other arm at a point 2 inches from the end.
- c. The force in pounds required to open the hose to an approximate 90-degree angle shall be determined by a spring balance or other convenient means.
- d. The temperatures shall be held at $-67^{\circ} \pm 2^{\circ}\text{F}$ during the test.

4.7.3.7.2 Hose ID 3- inch or 4 inch. Hose in the 3 inch and 4 inch ID size shall be tested by bending an uncoupled 5-foot length into a concave shape such that the ends of the hose are approximately 40 inches apart, tying it in that shape and conditioning it for not less than 72 hours at $-67^{\circ} \pm 2^{\circ}\text{F}$. The force in pounds required to straighten the hose to an approximate 180-degree angle shall be determined by any convenient means. The temperature shall be held at $-67^{\circ} \pm 2^{\circ}\text{F}$ during the test.

4.7.3.8 Sediment contamination and color change test (see 3.4.3.8). A length of hose when subjected to the sediment contamination and color change test shall meet the requirements of 3.4.3.8. The following details shall apply:

- a. While in a condition typical of a production length of hose just prior to the individual tests, the hose shall be filled with grade JP-4 or JP-5 fuel in accordance with MIL-DTL-5624, or JP-8 in accordance with MIL-DTL-83133 or reference fuel B conforming to ASTM D471.
- b. The fuel shall contain no more than 1 milligram per liter of sediment contamination.
- c. The filled hose shall stand for 72 hours.
- d. After this period, an amount of fuel equal to one-half of the volume of the hose sample shall be drained from the downstream end and discarded.
- e. A 1-liter sample of fuel shall be obtained and analyzed for solid contamination in accordance with ASTM D2276.
- f. If the total rise in sediment exceeds 2 milligrams per liter, it shall be cause for rejection.
- g. The fuel color before and after the 72-hour period shall be determined in accordance with ASTM D156 and shall not exceed a change of 40.

MIL-DTL-6615G
w/AMENDMENT 1

PACKAGING

5.1 Packaging. For acquisition purposes, the packaging requirements shall be as specified in the contract or order (see 6.2). When packaging of material is to be performed by DoD or in-house contractor personnel, these personnel need to contact the responsible packaging activity to ascertain packaging requirements. Packaging requirements are maintained by the Inventory Control Point's packaging activity within the Military Service or Defense Agency, or within the Military Service's System Commands. Packaging data retrieval is available from the managing Military Department's or Defense Agency's automated packaging files, CD-ROM products, or by contacting the responsible packaging activity.

6. NOTES

(This section contains information of a general or explanatory nature which may be helpful, but is not mandatory.)

6.1 Intended use. These military unique hose assemblies are used in ground fueling operations requiring low temperature flexibility and bend operations to -67°F (-55°C), or in non-potable demineralized water applications. The hose of the assembly must be compatible with military unique reattachable couplings in accordance with SAE-AS38404, A-A-59326/2 and A-A-59326/6 with caps and plugs. Class 1 couplings in accordance with SAE-AS38404 couplings are used for hydrocarbon fuels. Class 2 couplings are used for non-potable demineralized water applications.

6.2 Ordering data. Acquisition documents must specify the following:

- a. Title, number, and date of this specification.
- b. PIN (see 1.2)
- c. When contract or order number is to be included on the label (see 3.7.1).
- d. First article (see 4.5) or whether first article inspection is waived (6.3.1).
- e. Lot records if required (see 4.4.1).
- f. Name and address of the first article inspection test facility to which first article samples, if required, are to be forwarded (see 4.5.4) and the name and address of the Government activity responsible for conducting the first article inspection program (see 6.3).
- g. Shelf life requirements (see 6.4)
- h. Packaging requirements (see 5.1).

6.3 First article. The contracting officer should include specific instructions in acquisition documents regarding arrangements for examinations, approval of first article test results, and disposition of first article samples. Invitations for bids should provide that the Government reserves the right to waive the requirement for samples for first article inspection to those bidders offering a product which has been previously acquired or tested by the Government, and that bidders offering such products, who wish to rely on such production or test, must furnish evidence with the bid that prior Government approval is presently appropriate for the pending contract.

6.3.1 Defense Logistics Agency (DLA) waiver of first article test. A waiver of a first article testing will only be considered by DLA when the contractor has delivered the same item within the last three years, has no unfavorable quality history, has not changed processes, or changed any subcontractors. DLA will not accept first article testing results outside the stated requirements.

MIL-DTL-6615G
w/AMENDMENT 1

6.4 Shelf life. This specification covers items where the assignment of a Federal shelf-life code is a consideration. Specific shelf-life requirements should be specified in the contract or purchase order, and should include, as a minimum, shelf-life code, shelf-life code, shelf-life package markings in accordance with MIL-STD-129 or FED-STD-123, preparation of a materiel quality storage standard for type II (extendible) shelf-life items, and a minimum of 85 percent shelf-life remaining at time of receipt by the Government. These and other requirements, if necessary, are in DoD4140.27-M, *Shelf-life Management Manual*. The shelf-life codes are in the Federal Logistics Information System Total Item Record. Additive information for shelf-life management may be obtained from DoD 4140.27-M, or the designated shelf-life Points of Contact (POC). The POC should be contacted in the following order: (1) the Inventory Control Points that manage the item and (2) the DoD Service and Agency administrators for the DoD Shelf-Life Program. Appropriate POCs for the DoD Shelf-Life Program can be contacted through the DoD Shelf-Life Management website: <http://www.shelflife.hq.dla.mil/>.

6.5 Environmentally preferable material. Environmentally preferable materials should be used to the maximum extent possible to meet the requirements of this specification. As of the dating of this document, the U.S. Environmental Protection Agency (EPA) is focusing efforts on reducing 31 priority chemicals. The list of chemicals is available on their website at <http://www.epa.gov/epawaste/hazard/wastemin/index.htm>. Included in the EPA list of 31 priority chemicals are cadmium, lead, and mercury. Use of the materials on the list should be minimized or eliminated unless needed to meet the requirements specified herein (see section 3).

6.6 Guidance on use of alternative parts with less hazardous or nonhazardous materials. This specification provides for a number of alternative plating materials via the PIN. Users should select the PIN with the least hazardous material that meets the form, fit and function requirements of their application.

6.7 Subject term (key word) listing.

Hydrocarbon
Inner tube
Quick disconnect

6.8 Amendment notations. The margins of this specification are marked with vertical lines to indicate modifications generated by this amendment. This was done as a convenience only and the Government assumes no liability whatsoever for any inaccuracies in these notations. Bidders and contractors are cautioned to evaluate the requirements of this document based on the entire content irrespective of the marginal notations.

MIL-DTL-6615G
w/AMENDMENT 1

CONCLUDING MATERIAL

Custodians:

Navy - AS
Air Force - 99
DLA - CC

Preparing activity:
DLA - CC

(Project 4720-2011-005)

Review activities:

Navy - CG, MC, SA, SH
Air Force - 71

NOTE: The activities listed above were interested in this document as of the date of this document. Since organizations and responsibilities can change, you should verify the currency of the information above using the ASSIST Online database at <https://assist.daps.dla.mil>.