

INCH-POUND

MIL-DTL-5886G

19 June 2000

SUPERSEDING

MIL-DTL-5886F

24 March 1995

(See 6.3)

DETAIL SPECIFICATION

CYLINDER, AIRCRAFT OXYGEN, LOW PRESSURE,

NONSHATTERABLE

This document remains Inactive for New Design.

This specification is approved for use by all Departments and Agencies of the Department of Defense.

1. SCOPE

1.1 Scope. This specification covers compressed gas low pressure storage cylinders with a working pressure of 450 psi for aerospace application.

2. APPLICABLE DOCUMENTS

2.1 General. The documents listed in this section are needed to meet the requirements specified in sections 3, 4, and 5 of this specification. This section does not include documents cited in other sections of this specification or recommended for additional information or as examples. While every effort has been made to ensure the completeness of this list, document users are cautioned that they must meet all specified requirements documents cited in sections 3, 4, and 5 of this specification, whether or not they are listed.

Beneficial comments (recommendations, additions, deletions) and any pertinent data which may be of use in improving this document should be addressed to: OC-ALC/TICLA, 3001 Staff Drive, Tinker AFB, OK 73145-5990 by using the Standardization Document Improvement Proposal (DD Form 1426) appearing at the end of this document or by letter.

AMSC N/A

FSC 1660

DISTRIBUTION STATEMENT A. Approved for public release; distribution is unlimited.

MIL-DTL-5886G

2.2 Government documents.

2.2.1 Specifications, and standards. The following specifications and standards form a part of this document to the extent specified herein. Unless otherwise specified, the issues of these documents are those listed in the issue of the Department of Defense Index for Specifications and Standards (DODISS) and supplement thereto, cited in the solicitation (see 6.2).

SPECIFICATIONS

FEDERAL

BB-A-1034	Compressed Air, Breathing
BB-N-411	Nitrogen, Technical
A-A-58092	Tape, Antiseize, Polytetrafluorethylene

DEPARTMENT OF DEFENSE

MIL-DTL-5886/1	Cylinder, Aircraft Oxygen, Low Pressure, Nonshatterable
MIL-PRF-27210	Oxygen, Aviator's Breathing, Liquid And Gas

STANDARDS

FEDERAL

FED-STD-595	Colors Used In Government Procurement
-------------	---------------------------------------

DEPARTMENT OF DEFENSE

MIL-STD-100	Engineering Drawing
MIL-STD-130	Identification Marking Of US Military Property

(Unless otherwise indicated, copies of federal and military specifications, and standards are available from the Standardization Documents Order Desk, Building 4D, 700 Robbins Ave, Philadelphia, PA 19111-5094)

2.3 Non-Government publication. The following document forms a part of this document to the extent specified herein. Unless otherwise specified, the issues of the documents which are DOD adopted are those listed in the issue of the DODISS cited in the solicitation. Unless otherwise specified, the issues of documents not listed in the DODISS are the issues of the documents cited in the solicitation (see 6.2).

MIL-DTL-5886G

American Society for Quality Control (ASQC)

ANSI/ASQC- Z1.4 Procedures, Sampling And Tables For Inspection By Attributes

(Application for copies should be addressed to the American Society for Quality Control, P.O. Box 3005, 611 E. Wisconsin Avenue, Milwaukee, WI 53201-4606)

American Society For Testing & Materials

ASTM E8 Standard Test Methods for Tension Testing of Metallic
Materials (AASHTO T68)

(Application for copies should be addressed to the American Society of Testing and Materials, 1916 Race St, Philadelphia, PA 19103-1187)

Metals and Alloys in the Unified Numbering System (UNS)

S30403 Austenitic Cr-Ni Stainless Steel (Low Carbon)
S31600 Austenitic Cr-Ni-Mo Stainless Steel

(Application for copies should be addressed to the Society of Automotive Engineers, Inc., 400 Commonwealth Drive, Warrendale, PA 15096)

National Aerospace Standards Committee (NA/NAS)

NAS847 Caps And Plugs, Protective, Dust And Moisture Seal

(Application for copies should be addressed to the Aerospace Industries Associated of America Inc., 1250 Eye Street N.W, Washington, DC 20005-3922)

Society of Automotive Engineers

SAE-ARP1176 Oxygen System And Component Cleaning And Packaging
SAE-AMS-STD-2219 Fusion Welding For Aerospace Application
SAE-AS4863 Plug, Pipe, External Thread

(Application for copies should be addressed to Society of Automotive Engineers, Inc., 400 Commonwealth Drive, Warrendale, PA 15096-0001)

2.4 Order of Precedence. In the event of a conflict between the text of this document and the references cited herein (except for the specification sheet), the text of this document takes precedence. Nothing in this document, however, supersedes applicable laws and regulations unless a specific exemption has been obtained.

MIL-DTL-5886G

3. REQUIREMENTS

3.1 Specification sheet. The individual item requirements shall be as specified herein and in accordance with the applicable specification sheet. In the event of any conflict between the requirements of this specification and the specification sheet, the latter shall govern.

3.1.2 First article. When specified (see 6.2), a sample shall be subjected to first article inspection in accordance with 4.3.

3.2 Materials. The materials used in all parts of the cylinders shall be in accordance with Metals And Alloys in The Unified Numbering System S30403, S31600, or stainless maraging steel conforming to the following chemical composition:

C	0.05 percent max.
Mn	0.5 percent max.
Si	0.3 percent max.
P	0.03 percent max.
S	0.02 percent max.
Cr	14.0 - 18.0 percent
Ni	6.0 - 7.0 percent
Ti	0.70 - 0.95 percent
Fe	Remainder

3.2.1 Reclaimed material. The use of reclaimed materials shall be encouraged to the maximum extent possible.

3.3 Design and construction. The design and construction of the cylinders shall be in accordance with the applicable part number of MIL-DTL-5886/1, as specified in the contract or order (see 6.2).

3.3.1 Welding. Welding shall be performed in accordance with SAE-AMS-STD-2219, Class A (see 4.5.7).

3.3.2 Closures. Cylinders with two openings shall have one plug conforming to SAE-AS4863, CRES type 304 or 316, while the other opening shall be closed with a removable metal threaded plug or cap conforming to NAS847. The cylinder with one opening shall be closed with a removable metal threaded plug or cap conforming to NAS847 or a commercially equivalent metal plug or cap, at the option of the contractor. These plugs or caps are required to protect the threads and prevent entrance of foreign matter or moisture (see 4.5.1).

3.3.3 Forming by pressurization. Forming by pressurization up to 900 psi as a manufacturing process is allowed. The permanent volumetric expansion test (see 4.5.4) is a separate requirement.

MIL-DTL-5886G

3.4 Performance.

3.4.1 Cleanliness. The cylinders, when tested as specified (see 4.5.1), shall pass the requirements in Table I as specified (see 4.5.2).

3.4.2 Leakage. The cylinder shall not show any evidence of leaks when tested as specified (see 4.5.3).

3.4.3 Permanent volumetric expansion. The cylinder shall not have a permanent volumetric expansion greater than 10 percent of the total volumetric expansion when tested as specified (see 4.5.4).

3.4.4 Burst pressure. The cylinder shall not burst at a pressure less than 1,000 PSI when tested as specified (see 4.5.5).

3.4.4.1 Cyclic endurance. The cylinder shall continue to hold pressure during the cyclic endurance portion of the test as specified (see 4.5.5.1).

3.4.5 Macrostructure defects. The cylinder shall show no evidence of abnormal segregation, pipes, cracks, carbide defects, seams or abnormal change in structure from the surface to the center when tested as specified (see 4.5.6).

3.4.6 Fragmentation. The cylinder shall remain in one piece and exhibit no evidence of shattering when tested as specified (see 4.5.8).

3.4.7 Physical properties. The cylinder material sample shall not have an ultimate tensile strength that exceeds 165,000 pounds per square inch and the elongation shall be at least 12 percent when tested as specified (see 4.5.10).

3.5 Weight. The weight of the cylinders shall not exceed the values specified on MIL-DTL-5886/1 (see 4.5.1).

3.6 Exterior finish. The color of the finish shall be gloss yellow in accordance with color number 13655 of FED-STD-595. The .375 X .750 hexagonal, wrench-flat surfaces and the adjacent end of the bottle between the threads and these wrench flats may be left unpainted. The external finish of all cylinders shall have a minimum paint thickness of 0.001 inches. The paint shall not crack, chip, or scale during normal service life or under extreme environmental conditions (see 4.5.9).

3.6.1 Humidity. The exterior finish when exposed to humidity shall not show evidence of corrosion, blistering, wrinkling or loss of adhesion (see 4.5.9.1).

3.6.2 Adhesion. The cured film coating shall have a minimum classification of 4B as specified in ASTM-D2247 (see 4.5.9.2).

MIL-DTL-5886G

3.7 Identification of product. Decals, if used in lieu of paint, shall be approved by the procuring activity. The cylinders shall be marked for identification in accordance with MIL-STD-130 and shall include the following information (see 4.5.1):

Oxygen Cylinder, Nonshatterable
M5886/1-*
MIL-DTL-5886
Volume & Pressure (Maximum fill pressure in psi and Kg/cm²)
Manufacturer's Part Number *
Contract Number *
Manufacturer's Name or Trademark *
Date of Manufacture

*The manufacturer shall include applicable information.

3.7.1 Additional marking. The cylinders shall be permanently and legibly marked on the neck, spud, wrench flats, or fitting of the cylinder, in figures not less than 0.060 inch in height, with the date of manufacture or hydrostatic test (month and year), such as 7-79, for July 1979. Each cylinder shall also be marked by painting or decals in two places diametrically opposite each other with the following information: "BREATHING OXYGEN AV". The height of the letters shall not be less than 0.375 inch and the color shall be a durable dull black. Paint material used shall be as specified (see 3.7) and decals, if used in lieu of paint, shall be approved by the procuring activity.

3.8 Interchangeability. All parts having the same manufacturer's part number shall be directly and completely interchangeable with each other with respect to installation and performance. Changes in manufacturer's part numbers shall be governed by the drawing number requirements of MIL-STD-100.

3.9 Workmanship. The cylinders shall be uniform in quality and shall be free from irregularities or defects which could adversely affect safety, performance, reliability, or durability. The cylinders shall be free of oil, grease, fuel, water, dust, dirt, or any other foreign matter.

4. VERIFICATION

4.1 Classification of inspections. The inspection requirements specified herein are classified as follows:

- a. First article inspection (see 4.3).
- b. Quality conformance inspection (see 4.4).

MIL-DTL-5886G

4.2 Inspection conditions.

4.2.1 Gas. Unless otherwise specified, the gas used in testing shall be oxygen conforming to MIL-PRF-27210, type I, nitrogen conforming to BB-N-411, type I, class 1, grade B, or air conforming to BB-A-1034.

4.2.2 Cleaning. Cleaning and cleanliness verification shall conform to SAE-ARP1176.

4.2.3 Temperature and pressure. Unless otherwise specified, tests shall be conducted at local ambient temperature and barometric pressure. The temperature and barometric pressure shall be recorded at the time of inspection. This information shall be available for computation of test data, when required, to normal temperature and pressure (NTP) conditions. Computations are not required unless required by contract. NTP conditions are 29.92 inches of mercury and 70⁰F (21.1⁰C). Test instruments shall be calibrated or adjusted according to their required usage in performing individual tests.

4.2.4 Antiseize tape. The male pipe threads of fittings installed in cylinders during tests shall be wrapped with antiseize tape conforming to A-A-58092 before being installed in the cylinders. The tape shall be applied according to instructions specified in A-A-58092. Tape shall be prevented from entering the inside of the fittings.

4.3 First article inspection. First article inspection shall consist of all the examinations and tests of this specification. Each sample shall be subjected to all the inspections and tests of this specification with the exception of the fragmentation test, the burst test, and the physical properties test as further explained (see 4.3.1).

4.3.1 First article samples. Unless otherwise specified, as soon as practicable after award of a contract or order, the manufacturer shall submit to the first article tests five sample cylinders of each MS part number specified in the contract or order, and four material samples cut from the walls in unaffected areas of four separate cylinders used for the burst and fragmentation tests specified (see 4.5.5 and 4.5.8), respectively. Three sample cylinders shall be used for the fragmentation test and the remaining two cylinders shall be used for the burst test. The samples shall be representative of the construction, workmanship, components, and materials to be used during production. When a contractor is in continuous production of these cylinders from contract to contract, submission of further first article samples on the new contract may be waived at the discretion of the procuring activity. Approval of the first article samples or the waiving of the first article inspection does not preclude the requirements of submitting to the quality conformance inspection. The first article samples shall be tested at a facility approved by the procuring activity (see 6.2). The first article samples shall be plainly identified by securely attached durable tags marked with the following information:

“Sample submitted by (name) (date) for first article inspection in accordance with MIL-DTL-5886 under contract no _____.”

MIL-DTL-5886G

The samples which are used for the first article inspection shall not be considered as part of the quantity to be delivered under contract. The tested samples shall be forwarded as directed by the procuring activity.

4.4 Conformance inspection. The conformance inspection shall consist of the following examinations and tests:

- a. Visual examination (4.5.1)
- b. Dimensions (4.5.1.1)
- c. Cleanliness (4.5.2)
- d. Leakage (4.5.3)
- e. Permanent volumetric expansion (4.5.4)
- f. Burst pressure (4.5.5)
- g. Macrostructure (4.5.6)
- h. Radiographic inspection (4.5.7)
- i. Physical properties (4.5.9)

Any defects detected by these tests may be corrected by rework. However, the macrostructure (see 4.5.6), radiographic inspection (see 4.5.7), and the physical properties (see 4.5.9) tests may reveal defects which are impracticable to rework. If the quantity of cylinders warrants the expense involved, the manufacturer may choose to accomplish the cyclic endurance test (see 4.5.5.1) to the particular cylinder or cylinders which fail (see 4.5.6, 4.5.7 or 4.5.9). Then the results of the failed test along with the results of the cyclic endurance test with appropriate recommendations/remedies shall be submitted to the procuring activity for consideration.

4.4.1 Inspection lot.

4.4.1.1 Cylinder. An inspection lot size shall be expressed in units of cylinders of the same size, made essentially under the same conditions and from the same materials and components. The sample unit shall be one cylinder.

MIL-DTL-5886G

4.4.1.2 Packaged lot. An inspection lot size shall be expressed in units of one fully prepared shipping container, containing cylinders fully prepared for delivery, made from essentially the same materials and components. The sample unit shall be one shipping container, containing cylinders fully prepared for delivery with the exception that it need not be sealed. When a manufacturer is essentially in continuous production, the inspection lot or sample lot quantities shall be considered on a continuous run basis rather than on procurement order quantities. Breaks in production in excess of 1 year will require re-initializing the run or lot.

4.4.2 Sampling.

4.4.2.1 Sampling for test and examinations of cylinders. The sample size, acceptance criteria, tests, and examinations required for the cylinders shall be as specified in Table I. The sampling plan of this specification shall take precedence over the SAE-AMS-STD-2219 sampling plans required for weld or radiographic inspections.

4.4.2.1.1 Alternate sample size procedure. The purpose of this alternate sampling size procedure is to minimize the quantity of cylinders destroyed during quality conformance testing. Except for the determination of the quantity of samples to be tested, all other criteria listed in table I shall still apply. If any units are rejected under this reduced sampling size procedures, the manufacturer shall use table I sampling procedure for the remainder of the cylinders subject to conformance testing. This alternative is mandatory if the previous delivery requirements (see 4.4.2.1.2) have been met, otherwise, the standard sampling plan shall be used. To use the alternate procedure the cylinders must be manufactured under the same processes, from the same materials, be the same size and be manufactured at the same facilities. There is no requirement that production be continuous or that materials shall be delivered from the same lot. For simplicity, the variables shall be defined as follows:

- A4 - the number of cylinders delivered to the Department of Defense in the last 4 years.
- A3 - the number of cylinders delivered to the Department of Defense in the last 3 years.
- A2 - the number of cylinders delivered to the Department of Defense in the last 2 years.
- B - the current order quantity subject to quality conformance testing.
- C4 - the quantity previously tested in the past 4 years.
- C3 - the quantity previously tested in the past 3 years.
- C2 - the quantity previously tested in the past 2 years.
- D - the quantity to be tested on the current order.

Exception: If the procedure of 4.4.2.1.1 would cause more than 2% of the cylinders to be destructively tested (see 4.5.5, 4.5.6 and 4.5.9), then the following procedure shall be used for these 3 tests only:

One out of each 50 cylinders manufactured, regardless of order quantity, the quantity to be delivered or the lot size shall be randomly selected and subjected to these tests (see 4.5.5, 4.5.6 and 4.5.9).

MIL-DTL-5886G

4.4.2.1.2 Computations.

- a. Four year plan. The following formula applies if $A_4+B>500$ cylinders and $A_4>200$ cylinders:

$$\frac{C_4+D}{A_4+B} > 1\%$$

If a value of $D = 0$ causes the number on the left side of the equation to exceed 1%, then 1 cylinder shall be tested. Otherwise D shall be the smallest number that causes the left side of the equation to exceed 1%.

- b. Three year plan. The following formula applies if $A_3+B>90$ cylinders and $A_3>40$ cylinders:

$$\frac{C_3+D}{A_3+B} > 2\%$$

If a value of $D = 0$ causes the number on the left side of the equation to exceed 2%, then 1 cylinder shall be tested. Otherwise D shall be the smallest number that causes the left side of the equation to exceed 2%.

- c. The following formula applies if $A_2+B>25$ cylinders and $A_2>15$ cylinders:

$$\frac{C_2+D}{A_2+B} > 3\%$$

If a value of $D = 0$ causes the number on the left side of the equation to exceed 3%, then 1 cylinder shall be tested. Otherwise D shall be the smallest number that causes the left side of the equation to exceed 3%.

4.5 Methods of inspection.

4.5.1 Visual examination. The cylinders shall be examined to determine conformance to configuration of type specified, internal cleanliness, finish, color markings, and other requirements not covered by specific examinations or tests. Examination of the internal surface shall be accomplished by inserting an inspection light into the cylinder. The defects discovered by examination of product shall be classified in accordance with Table II.

4.5.1.1 Dimensions. The cylinder shall be checked dimensionally to determine conformance to MIL-DTL-5886/1.

4.5.2 Cleaning. Cleaning shall be accomplished in accordance with SAE-ARP1176 (see 3.4.1).

MIL-DTL-5886G

4.5.3 Leakage. The cylinder shall be charged with a test gas (see 4.2.1) to a pressure of 500 psig. With this pressure maintained, the cylinder shall be submerged in water for 2 minutes. All parts of the cylinder shall be covered with at least 1 inch of water. Constraints necessary to hold the cylinder in place shall not cover the welded seams of the pressure vessel. Cylinders with two openings shall be tested after the SAE-AS4863 plug has been installed and properly torqued. The cylinder shall pass the requirements specified (see 3.4.2). This test shall not apply to cylinders greater than 2200 cubic inches.

4.5.4 Permanent volumetric expansion. The permanent volumetric expansion shall be determined by hydrostatically testing the cylinder in a water jacket to a pressure of 750 psig for a period of not less than 1 minute. The expansion shall be determined to an accuracy of 1 percent or 0.1 of a cubic centimeter, and shall be recorded in cubic centimeters. The cylinder shall meet the requirements specified (see 3.4.3).

4.5.5 Burst pressure. The cylinders shall be hydrostatically pressurized for 3 minutes to within 95 percent of the pressure specified (see 3.4.4). Pressure shall be applied at the rate of 25,000 \pm 10,000 psi per minute. The cylinders shall then be tested hydrostatically to destruction and the bursting pressure recorded. The cylinders shall pass the requirements specified (see 3.4.4). At the suppliers option a cylinder tested for cyclic endurance (see 4.5.5.1) may be used for this test.

4.5.5.1 Cyclic endurance. The setup for this test is identical to that used during the burst test (see 4.5.5). The test cylinder shall be hydrostatically pressurized to the pressure specified (see 3.4.4) \pm 50 psi. Pressure shall be applied at a rate of 25,000 \pm 10,000 psi per minute for 1000 cycles. The pressure shall drop below 50 psi each cycle. After completion of this test, the cylinder shall then be subjected to the burst pressure test (see 4.5.5). The cylinder shall pass the requirements (see 3.4.4.1).

4.5.6 Macrostructure (deep acid etch). Longitudinal sections from the cylinder, taken from the burst cylinder (see 4.5.4), shall be etched in an aqueous solution containing 50 percent hydrochloric acid by volume and maintained at a temperature of approximately 160⁰F (71⁰C) for sufficient time to show the presence of defects. The sections shall then be visually examined by a metallographist and shall pass the requirements specified (see 3.4.5).

4.5.7 Welding. The longitudinal and circumferential sections of cylinders shall pass the inspection requirements of SAE-AMS-STD-2219. This shall be done prior to the installation of any strapping which otherwise would cover the weld. The welds of each end fitting (if required) and the welds used to attach reinforcing strapping shall not require radiographic inspection. The welded sections shall pass the requirements specified (see 3.3.1).

4.5.8 Fragmentation resistance. Oxygen shall be the charging gas for oxygen cylinders. Cylinders shall be subjected to gunfire under the following conditions:

- a. The cylinder shall be charged to rated pressure at gun range ambient air temperature.
- b. The cylinder may be supported but not constrained.

MIL-DTL-5886G

- c. The ammunition shall be .50 caliber M-2, armor piercing, with muzzle velocity of 2,800 \pm 100 feet per second (853 + 30 m/s).
- d. The range shall be 50 yards (45.7 m) maximum.
- e. The various cylinders taken for test shall be tested, each progressively, in a different position, as follows:
 - (1) With the longitudinal axis of the cylinder normal to line of fire.
 - (2) With the longitudinal axis of the cylinder 45⁰ degrees (.785 rad) from normal toward the gun position.
 - (3) With the longitudinal axis of the cylinder parallel to the line of fire with inlet port face away from the gun position.
- f. All shots shall be tumbled utilizing the method shown in Figure 1.
- g. The tumbled projectile shall have a minimum velocity of 2,600 ft/sec (792 m/s) at the point of impact with the cylinder.
- h. The minimum size entry hole made by the tumbled projectile shall be 0.50 inch by 1.50 inch (13mm by 39mm).
- i. Verify that the projectile trajectory and tumble are satisfactory. This may be determined by the location and visual appearance of a hole made by the passage of the projectile through vertically suspended sheets of paper at the target area.

The cylinder shall pass the requirements specified (see 3.4.6).

4.5.9 Exterior finish. Paint thickness shall be verified in accordance with ASTM-D1186, method B, to determine the total thickness of the film coating applied to the cylinder. The minimum allowable thickness shall be as specified (see 3.6).

4.5.9.1 Humidity. Humidity resistance shall be verified using ASTM-D2247. Cylinders shall be exposed to 120 \pm 5° F and 100% relative humidity for 7 days before performing the test. The film coating after the test shall be as specified (see 3.6.1).

4.5.9.2 Adhesion. Adhesion shall be verified in accordance with ASTM-D3359, method B, and have a classification of 4B (see 3.6.2).

4.5.10 Physical properties. Material samples taken from burst cylinder (see 4.5.5), as specified (see 4.3.1) and table I shall be tested for tensile strength and elongation in accordance ASTM E8. The samples shall meet the requirements specified (see 3.4.7).

MIL-DTL-5886G

5. PACKAGING.

5.1 Packaging. For acquisition purposes, the packaging requirements shall be as specified in the contract or order (see 6.2). When actual packaging of materiel is to be performed by DoD personnel, these personnel need to contact the responsible packaging activity to ascertain requisite packaging requirements. Packaging requirements are maintained by the Inventory Control Point's packaging activity within the Military Department or Defense Agency, or within the Military Department's System Command. Packaging data retrieval is available from the managing Military Department's or Defense Agency's automated packaging files, CD-ROM products, or by contacting the responsible packaging

6. NOTES

(This section contains information of a general or explanatory nature that may be helpful, but is not mandatory.)

6.1 Intended use. The cylinders covered by this specification are intended for use in storing aviator's breathing oxygen in aircraft having low pressure oxygen systems.

6.2 Acquisition requirements. Acquisition documents must specify the following:

- a. Title, number, and date of this specification.
- b. Issue of DODISS to be cited in the solicitation, and if required, the specific issue of individual documents referenced (see 2.1).
- c. Applicable part number (see 3.3).
- d. Where the samples should be delivered (see 4.3.1).
- e. When first article is required. Cylinders subjected to destructive tests (see Table I) shall not be shipped or considered as part of the contract or order.
- f. Selection of applicable levels of preservation, level A.
- g. Additional marking, **Oxygen Components - All oil, grease, shop residue, or other contaminants have been removed.**

Do not open until ready for use.

MIL-DTL-5886G

6.3 Supersession data. This specification supersedes the following specifications:

MIL-C-5435A, dated 21 May 1951
MIL-C-5436A, dated 21 May 1951
MIL-C-5887 (USAF), dated 21 February 1951
MIL-C-5888 (USAF), dated 21 February 1951
MIL-C-5889 (USAF), dated 21 February 1951
MIL-C-5890 (USAF), dated 21 February 1951
MIL-C-5891 (ASG) dated 10 April 1953

6.4 Subject term (key word)listing.

Burst pressure
Cleanliness
Closures
Cyclic endurance
Forming by pressurization
Fragmentation
Leakage
Macrostructure
Radiographic

6.5 International standardization agreement. Certain provisions of this specification (see 3.8) are the subject of international standardization agreement STANAG 3056. When amendment, revision or cancellation of this specification is proposed which will affect or violate the international agreement concerned, the preparing activity will take appropriate reconciliation action through international standardization channels including departmental standardization offices, if required.

6.6 Changes from previous issue. Marginal notations are not used in this revision to identify changes with respect to the previous issue due to the extensiveness of the changes.

MIL-DTL-5886G

TABLE I. Sample size, acceptance criteria, tests and examination of the cylinders.

Inspection	Method paragraph	Sample size	Acceptance criteria
Visual examination (see classification of defects)	4.5.1	Every cylinder for critical defects. <u>1</u> / Inspection level S-2 for minor defects	Reject all units with any. critical defects. Acceptance number zero, rejection number 1 for minor defects.
Dimensions	4.5.1.2	<u>1</u> / Inspection level S-2	Acceptance number zero, rejection number 1.
Cleanliness	4.5.2	<u>1</u> / Inspection level S-2	Acceptance number zero, rejection number 1
Leakage	4.5.3	Every cylinder	Reject all defective units.
Permanent volumetric expansion	4.5.4	Every cylinder	Reject all defective units.
Burst pressure <u>2</u> /	4.5.5	<u>1</u> / Inspection level S-2	Acceptance number zero, rejection number 1.
Macrostructure	4.5.6	<u>1</u> / Inspection level S-2 <u>3</u> /	Acceptance number zero, rejection number 1.
Radiographic inspection	4.5.7	<u>1</u> / Inspection level S-2	Acceptance number zero, rejection number 1.
Physical properties	4.5.9	<u>1</u> / Inspection level S-2 <u>4</u> /	Acceptance number zero, rejection number 1.

1/ The sample size shall be based only on the applicable sample size code letter corresponding to the specified inspection level of ASQC-Z1.4.

2/ This is a destructive test (see 6.2).

3/ The burst Pressure sample may be used. However, the longitudinal section shall be taken at locations not affected by the burst point.

4/ One sample from unaffected area of burst pressure sample unit.

MIL-DTL-5886G

TABLE II. Classification of defects for visual examination of the cylinder.

Defects	Minor	Critical
Incorrect outlet configuration		X
Incorrect or defective threads		X
Incorrect, incomplete, or faulty finish	X	
Flaw in the material		X
Incorrect or incomplete marking	X	
Incorrect color	X	
Abnormally distorted or nonuniform weld		X
Loose particles inside the cylinder		X
Rust or scale		X
Irregularities in the internal surface greater than 1/16 inch		X
Existence of any foreign material, solid or liquid		X

TABLE III. List of defects for preparation for delivery.

Item	Defects
Exterior and interior markings	Missing, incorrect, incomplete, illegible, improper size, location, sequence; or method of application; markings not the same on the interior and exterior containers.
Packaging and packing materials	Any non-conforming component; any component missing, damaged, or otherwise defective.
Workmanship	Inadequate application of the components such as incomplete closure of the unit package, intermediate package, container flaps, loose strappings, etc.; bulging or distortion of the containers.
Exterior and interior weight or content	Number per container is more or less than required; gross or net weight exceeds the requirements

MIL-DTL-5886G

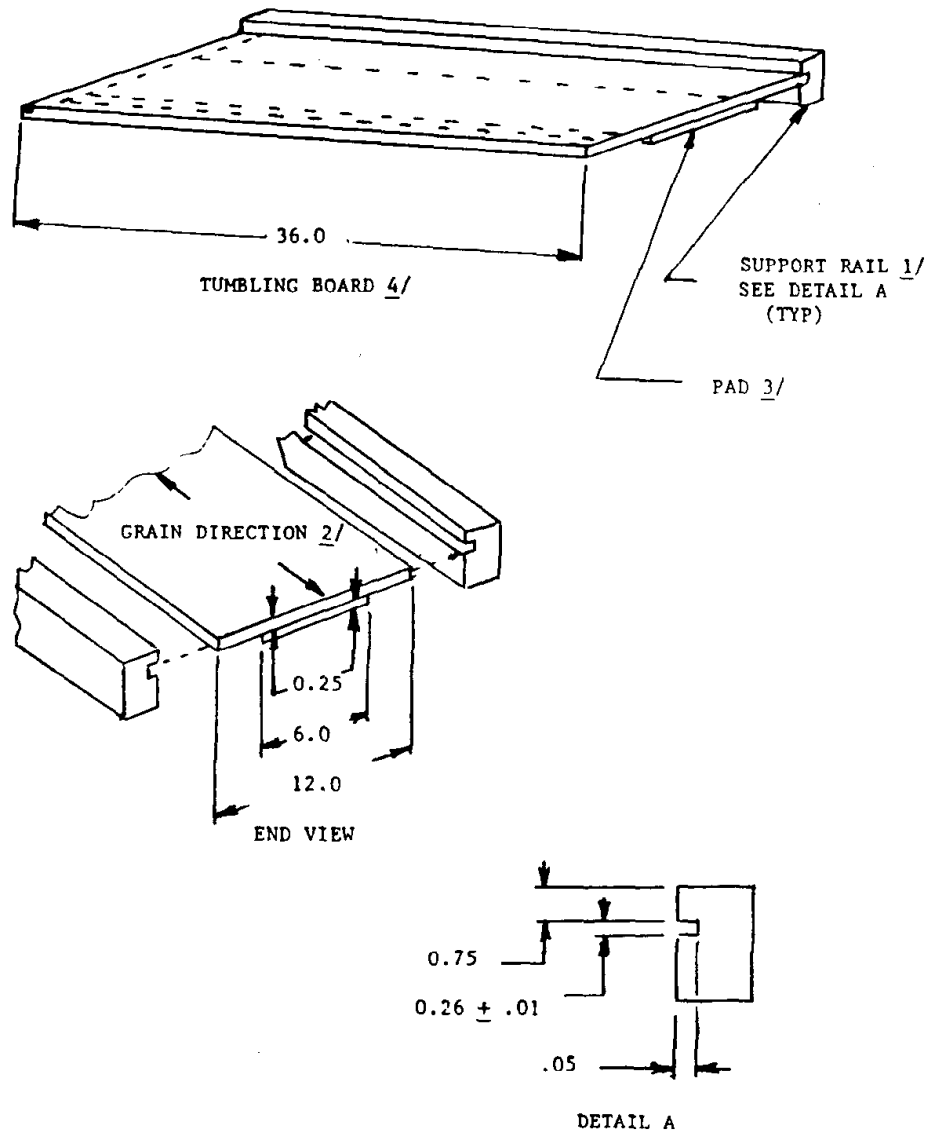
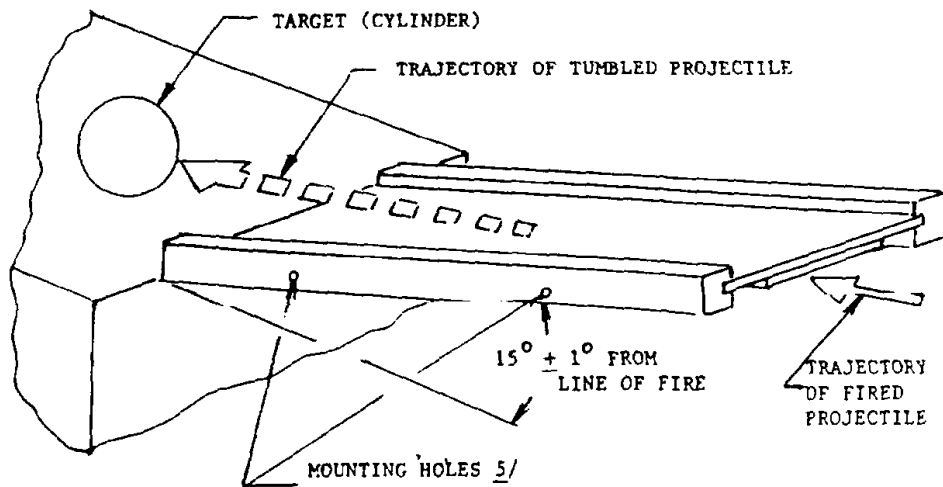

FIGURE 1. Projectile tumbling method

MIL-DTL-5886G



- 1/ Lumber, 2 x 4 - normal size
- 2/ Board, plywood - grade A-A, exterior type, 3 ply.
- 3/ Sheet, rubber-styrene-butadiene (RSB), 55 ± 5 durometer (shore A). Pad shall be cemented to entire length of tumbling board using a commercial contact cement.
- 4/ Tumbling board may be moved in the support rails for repeated firings.
- 5/ Mounting holes may be used to support tumbling board as required to ensure the board is rigidly mounted.

NOTES:

1. Dimensions are in inches.
2. Tolerance: decimals ± 0.1.

FIGURE 1. Projectile tumbling method - Continued

MIL-DTL-5886G

Custodians:

Army - AV

Navy - AS

Air Force - 99

Reviewer activities:

Air Force - 11
0811)

Preparing activity:

Air Force - 71

Agent:

Air Force - 99

(Project No. 1660-

STANDARDIZATION DOCUMENT IMPROVEMENT PROPOSAL

INSTRUCTIONS

1. The preparing activity must complete blocks 1, 2, 3, and 8. In block 1, both the document number and revision letter should be given.
2. The submitter of this form must complete blocks 4, 5, 6, and 7.
3. The preparing activity must provide a reply within 30 days from receipt of the form.

NOTE: This form may not be used to request copies of documents, nor to request waivers, or clarification of requirements on current contracts. Comments submitted on this form do not constitute or imply authorization to waive any portion of the referenced document(s) or to amend contractual requirements.

I RECOMMEND A CHANGE:

1. DOCUMENT NUMBER

MIL-DTL-5886F

2. DOCUMENT DATE (YYMMDD)

950324

3. DOCUMENT TITLE

CYLINDER, AIRCRAFT OXYGEN, LOW PRESSURE, NONSHATTERABLE

4. NATURE OF CHANGE (Identify paragraph number and include proposed rewrite, if possible. Attach extra sheets as needed.)

5. REASON FOR RECOMMENDATION

6. SUBMITTER

a. NAME (Last, First, Middle Initial)

b. ORGANIZATION

c. ADDRESS (Include Zip Code)

d. TELEPHONE (Include Area Code)

7. DATE SUBMITTED

(1) Commercial

(YYMMDD)

(2) AUTOVON

(If applicable)

8. PREPARING ACTIVITY

a. NAME

OC-ALC/LIIRC

b. TELEPHONE (Include Area Code)

(1) Commercial

(2) AUTOVON

c. ADDRESS (Include Zip Code)

3001 STAFF DRIVE
TINKER AFB, OK 73145-5990**IF YOU DO NOT RECEIVE A REPLY WITHIN 45 DAYS, CONTACT:**

Defense Quality and Standardization Office

5203 Leesburg Pike, Suite 1403, Falls Church, VA 22041-3466

Telephone (703) 756-2340 AUTOVON 289-2340