

MIL-DTL-5757M

2.2 Government documents.

2.2.1 Specifications, standards, and handbooks. The following specifications, standards, and handbooks form a part of this document to the extent specified herein. Unless otherwise specified, the issues of these documents are those cited in the solicitation or contract.

DEPARTMENT OF DEFENSE

SPECIFICATIONS

[MIL-DTL-45204](#) - Gold Plating, Electrodeposited.

STANDARDS

[MIL-STD-202](#) - Test Method Standard, Electronic and Electrical Component Parts.
[MIL-STD-202-101](#) - Test Method Standard Method 101, Salt Atmosphere (Corrosion).
[MIL-STD-202-105](#) - Test Method Standard Method 105, Barometric Pressure (Reduced).
[MIL-STD-202-107](#) - Test Method Standard Method 107, Thermal Shock.
[MIL-STD-202-112](#) - Test Method Standard Method 112, Seal.
[MIL-STD-202-204](#) - Test Method Standard Method 204, Vibration, High, Frequency.
[MIL-STD-202-208](#) - Test Method Standard Method 208, Solderability.
[MIL-STD-202-210](#) - Test Method Standard Method 210, Resistance to Soldering Heat.
[MIL-STD-202-211](#) - Test Method Standard Method 211, Terminal Strength.
[MIL-STD-202-212](#) - Test Method Standard Method 212, Acceleration.
[MIL-STD-202-213](#) - Test Method Standard Method 213, Shock (Specified Pulse).
[MIL-STD-202-214](#) - Test Method Standard Method 214, Random Vibration.
[MIL-STD-202-215](#) - Test Method Standard Method 215, Resistance to Solvents.
[MIL-STD-202-301](#) - Test Method Standard Method 301, Dielectric Withstanding Voltage.
[MIL-STD-202-302](#) - Test Method Standard Method 302, Insulation Resistance.
[MIL-STD-202-303](#) - Test Method Standard Method 303, DC Resistance.
[MIL-STD-202-307](#) - Test Method Standard Method 307, Contact Resistance.
[MIL-STD-202-311](#) - Test Method Standard Method 311, Life, Low Level Switching.
[MIL-STD-202-312](#) - Test Method Standard Method 312, Life, Intermediate, Current Switching.
[MIL-STD-883](#) - Method Standard Microelectronics.
[MIL-STD-1285](#) - Marking of Electrical and Electronic Parts.

(See [supplement 1](#) for list of associated specification sheets.)

(Copies of these documents are available online at <http://quicksearch.dla.mil>.)

2.3 Non-Government publications. The following documents form a part of this document to the extent specified herein. Unless otherwise specified, the issues of these documents are those cited in the solicitation or contract.

INSTITUTE of ELECTRICAL and ELECTRONICS ENGINEERS (IEEE)

[IEEE315](#) - Graphic Symbols for Electrical and Electronics Diagrams (including reference designation letters).

(Copies of this document are available online at www.ieee.org.)

INTERNATIONAL STANDARDIZATION ORGANIZATION (ISO)

[ISO10012](#) - Measurement Management Systems - Requirements for Measurement Processes and Measuring Equipment

(Copies of this document are available online at www.ansi.org.)

MIL-DTL-5757M

NATIONAL CONFERENCE of STANDARDS LABORATORIES (NCSL)

[NCSL Z540.3](#) - Calibration of Measuring and Test Equipment, Requirements for

(Copies of this document are available online at www.ncsli.org.)

SOCIETY OF AUTOMOTIVE ENGINEERS (SAE)

[SAE-AMS-QQ-N-290](#) - Nickel Plating (Electrodeposited).

(Copies of this document are available online at www.sae.org.)

MIL-DTL-5757M

2.4 Order of precedence. Unless otherwise noted herein or in the contract, in the event of a conflict between the text of this document and the references cited herein (except for related specification sheets), the text of this document takes precedence. Nothing in this document, however, supersedes applicable laws and regulations unless a specific exemption has been obtained.

3. REQUIREMENTS

3.1 Specification sheets. The individual item requirements shall be as specified herein and in accordance with the applicable specification sheet. In the event of any conflict between the requirements of this specification and the specification sheet, the latter shall govern.

3.2 Qualification. Relays furnished under this specification shall be products which are authorized by the qualifying activity for listing on the applicable Qualified Products List (QPL) at the time of award of contract (see 4.3, 4.4, 4.4.1 and 6.3). The Qualified Products List (QPL) associated with this inactive for new design specification will be maintained until acquisition of the product is no longer required whereupon the specification and QPL will be canceled.

3.2.1 Qualification and maintenance by similarity. Relays furnished under this specification may be qualified and maintained by similarity with other relays in the generic family. Manufacturer's which desire to qualify and maintain products in this same manner shall request this method from the qualifying activity. The manufacturer shall submit their test plans for the qualifying activity to evaluate. The following are examples of items to be included in the request, but are not inclusive.

- a. Difference between relays.
- b. Tests for each relay.
- c. Characteristics of each relay such as:

<u>Contact assembly</u>	<u>Coil assembly</u>	<u>External material</u>
Contact material	Coil wire size	Case material
Contact size	Coil bobbin	Plating
Contact configuration	Ampere turns	Welding process

- d. Any other items that may be affected by the differences in design.

3.3 Materials. Materials shall be as specified herein. However, when a definite material is not specified, a material shall be used which will enable the relays to meet the performance requirements of this specification. Materials used externally shall be fungus inert, self-extinguishing, and shall not support combustion, nor give off noxious gases in harmful quantities. Materials used internally shall not give off gases in quantities sufficient to cause explosion of sealed enclosures, cause contamination of the contacts or other parts of the relay that will adversely affect life or reliability, or form current-carrying tracks when subjected to any of the tests specified herein. Cotton-filled or wood-flour-filled materials shall not be used. Ceramic used for external surfaces shall be glazed. The use of silicone (see 6.8) or silicone compounds for any purpose is prohibited. The selection of materials shall be such as to provide maximum shelf life. Acceptance or approval of any constituent material shall not be construed as a guaranty of the acceptance of the finished product.

3.3.1 Metals. Metals shall be of a corrosion-resistant type or shall be plated or treated to resist corrosion. The use of mercury or mercury compounds is prohibited. The use of magnesium or magnesium alloys is prohibited (not applicable to contacts).

3.3.1.1 Plated finishes.

- a. The use of pure tin, as an underplate or final finish, is prohibited both internally and externally. Tin content of relay and solder shall not exceed 97 percent, by mass. Tin shall be alloyed with a minimum of 3 percent lead, by mass (see 6.5)
- b. Use of zinc plating is prohibited internally and externally.
- c. Use of cadmium plating is prohibited internally and externally.

MIL-DTL-5757M

3.3.1.2 Dissimilar metals. When dissimilar metals are used in intimate contact with each other, protection against electrolysis and corrosion shall be provided. The use of dissimilar metals in contact, which tends toward active electrolytic corrosion (particularly brass, copper, or steel used in contact with aluminum or aluminum alloy), is not acceptable. However, metal spraying or metal plating of dissimilar base metals to provide similar or suitable abutting surfaces is permitted. Dissimilar metals should be as defined in 6.6. In hermetic seals, the 0.25 V difference between the header material and the housing material is not applicable.

3.3.2 Magnet wire. Magnet wire used shall enable the relay to meet the performance requirements of this specification.

3.3.3 Recycled, recovered, environmentally preferable, or biobased materials. Recycles, recovered, environmentally preferable, or biobased materials should be used to the maximum extent possible, provided that the material meets or exceeds the operational and maintenance requirements, and promotes economically advantageous life cycle costs.

3.4 Interface and construction requirements. Relays shall meet the interface and construction requirements as specified (e.g. weight, physical dimensions) (see 3.1).

3.4.1 Case. Unless otherwise specified (see 3.1), the case shall not be electrically connected to the contacts or coil; however, it may be used as part of the magnetic circuit.

3.4.1.1 Case grounding. When specified (see 3.1), a means for connecting the relay case to ground shall be provided.

3.4.2 Sealing process. Relays shall be dried, degassed, backfilled with an atmosphere, and sealed in such a manner that all the requirements of this specification are met. Adjunct sealant (see 6.8), if used, must comply with the following characteristics:

- a. Shall not extend above 20 percent of the length of the exposed terminals above the glass meniscus.
- b. Trace color is permitted if it is a natural result of the sealant process.
- c. Shall form, after curing, a permanent nonconductive, noncracking seal under all relay environments.

3.4.3 Contacts. Contacts shall have load ratings and arrangements as specified (see MIL-STD-1285 and 3.1) and unless otherwise specified (see 3.1), shall be capable of carrying the maximum rated current continuously as well as making and breaking the specified current under all environmental conditions specified herein.

3.4.3.1 Orientation of contact motion (dry reed relays only). The flat surface of the reed contact shall be parallel to two sides at right angles to the relay housing unless otherwise specified (see 3.1).

3.4.3.2 Switch capsules. Unless otherwise specified (see 3.1), switch capsules used in dry reed relays shall be such that the performance requirements of this specification are met. Switch capsule leads shall not be used as terminals.

3.4.4 Coils. Coils shall be adequately insulated electrically from the contacts and the case. The resistance and rated voltage (or current) shall be as specified (see 3.1). Coils shall be designed for continuous operation at maximum rated voltage (or current) and temperature, unless otherwise specified (see 3.1).

3.4.4.1 Terminal identification. When specified (see 3.1), a bead of contrasting color shall be used to designate the X1 (positive, if applicable) terminal (see figure 1 and MIL-STD-1285).

MIL-DTL-5757M

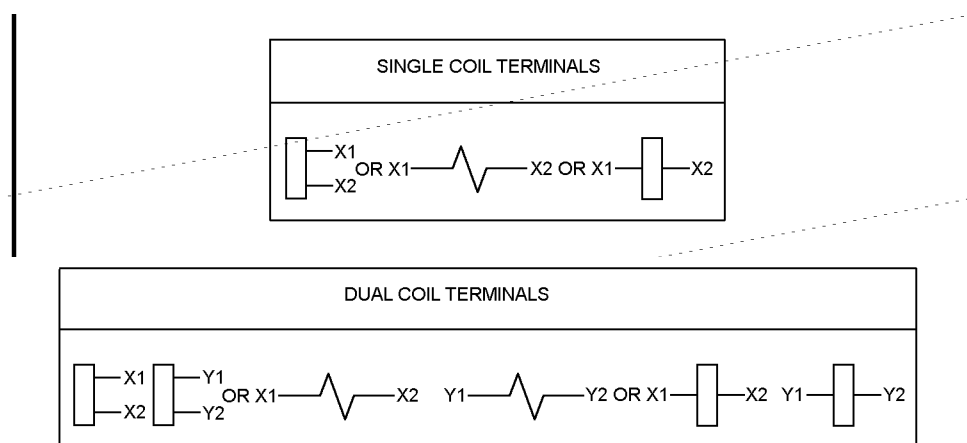

FIGURE 1. Terminal symbols and markings.

MIL-DTL-5757M

3.4.5 Circuit diagram. The circuit diagram as specified (see 3.1), shall be a terminal view. Circuit symbols shall be in accordance with [IEEE315](#). For relays without an orientation tab, the circuit diagram, as specified (see 3.1), shall be oriented so that when the relay is held with the circuit diagram right side up as shown (see 3.1), and rotated away from the viewer about a horizontal axis through the diagram until the header terminals face the viewer, then each terminal shall be in the location shown in the circuit diagram.

3.4.6 Mounting means (see 3.1).

3.4.6.1 Bracket. Mounting brackets shall be an integral part of the relay, securely attached thereto in a manner to prevent any movement between the relay and the mounting bracket.

3.4.7 Terminals (see 3.1). Terminals shall be as specified herein. Manufacturer may supply hot solder dipped terminals provided that the hot solder dipping process has been approved by the qualifying activity and when specified on the individual order (see 6.2.1a). Solder dipped terminals may be .002 inch (0.05 mm) larger than the maximum dimension specified (see 3.1). Icicles are a normal result of the hot solder dip process and shall not be grounds for rejection (see [figure 2](#)).

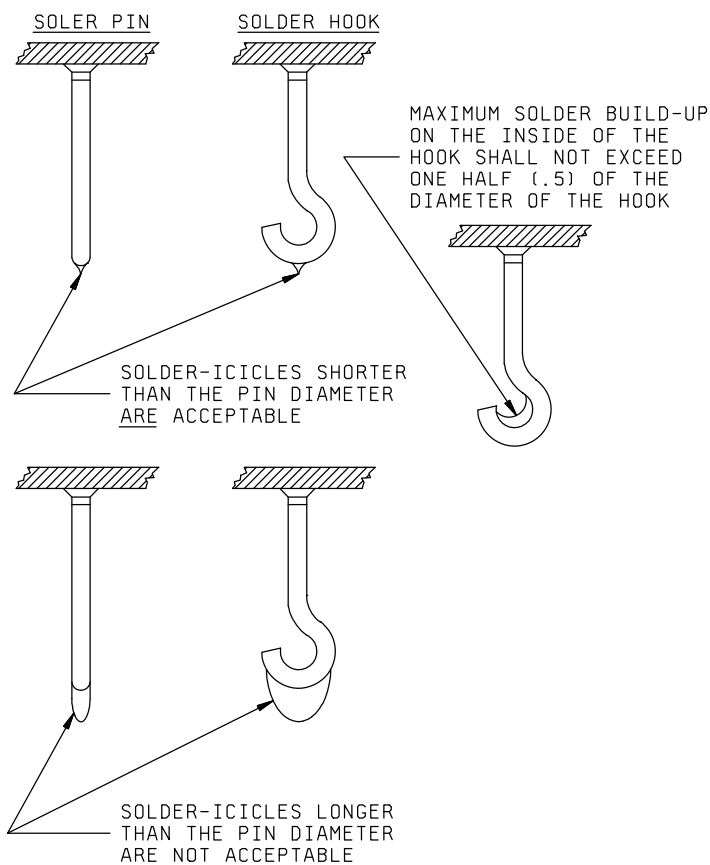

NOTES:

1. No solder is allowed on the header surface. Components (relay terminals) after solder-dip shall be capable of meeting [MIL-STD-202-208](#), solderability requirements.
2. Solder-coat thickness shall be .0001 inch (.003 mm) minimum.

FIGURE 2. Solder-dip acceptability criteria (solder-icicle length limits).

MIL-DTL-5757M

3.4.7.1 Solder lug terminals. Solder lug terminals shall be designed to accommodate two conductors, each rated to carry the maximum rated current of the contact or coil terminated.

3.4.7.2 Wire leads. Wire leads shall be as specified (see 3.1). Optional, shortened wire leads may be supplied when specified on the individual order (see 3.1 and 6.2.1b).

3.4.7.2.1 Wire leads, solder pin (SP). Solder pin wire leads shall be as specified (see 3.1).

3.4.7.3 Wire marks. When plating is used, an underplating of copper may be used to assure good adhesion. A slight exposure of copper underplating or other underplating resulting from wire wrapping necessitated by the plating operation is acceptable (see figure 3).

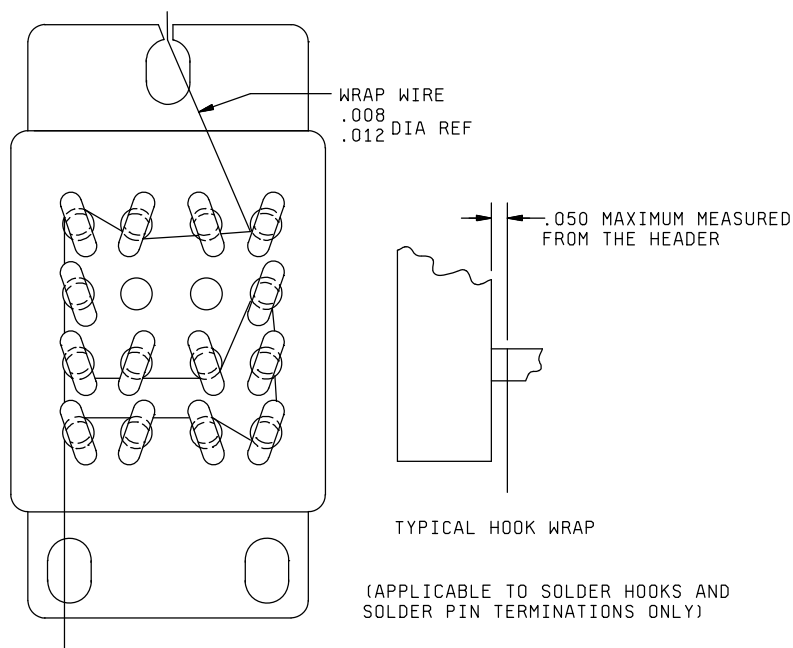

FIGURE 3. Wire marks.

3.4.7.4 Plug-in termination. Plug-in terminations shall conform to the arrangements or dimensions as specified (see 3.1). The mounting arrangement of the relay shall be so designed that the entire weight of the relay will be suspended and the stability of its mounting will be provided by an auxiliary mounting means other than the electrical terminals of a socket (see 3.1). Plug-in terminals shall be gold plated in accordance with MIL-DTL-45204, type II, class I, with a nickel underplating that shall be in accordance with SAE-AMS-QQ-N-290 and 50 microinches to 150 microinches thick.

MIL-DTL-5757M

3.4.7.5 Solder dip (retinning) leads. The manufacturer may solder dip/retin the leads of product supplied to this specification provided the solder dip process has been approved by the qualifying activity.

3.4.7.5.1 Qualifying activity approval. Approval of the solder dip process will be based on one of the following options (NOTE: Solder dip of gold-plated plug-in leads is not allowed.) All visual examination criteria shall be in accordance with MIL-STD-202-208:

- a. The manufacturer shall use a qualifying activity approved solder dip process for retinning.
- b. When the lead originally qualified was not hot solder dip lead finish 52 as prescribed above, approval for the process to be used for solder dip shall be based on the following test procedure:
 - (1) Six samples for each style and lead finish are subjected to the manufacturer's solder dip process. Following the solder dip process, the relays shall be subjected to group A2 and group A4 inspections.
 - (2) Three of the six samples are then subjected to the solderability test (see 3.6). No visual defects are allowed.
 - (3) Remaining three samples are subjected to the resistance to soldering heat test (see 3.19).
 - (4) All six samples shall be subjected to group A2 and group A4 inspections. Minor scratching of the terminals due to insertion into test sockets shall not be cause for rejection.

3.4.7.5.2 Solder dip/retinning options. The manufacturer may solder dip/retin as follows:

- a. After the 100 percent group A1 screening tests and before the group A3 solderability test: Following the solder dip/retinning process, insulation resistance (all terminals to case), seal, and visual/mechanical inspection shall be performed.
- b. As a corrective action: If the lot fails the group A solderability test, insulation resistance (all terminals to case), seal, and visual/mechanical inspection shall be performed.
- c. For relays that have been subjected to and passed group A inspection: Following the solder dip/retinning process, insulation resistance (all terminals to case), seal, and visual/mechanical inspection shall be performed.

3.5 Screening (internal moisture; see 4.6.2; run-in, see 4.6.3). The contact miss detector's monitoring level shall be less than 100 ohms for relays tested during cycling. Unless otherwise specified (see 3.1), any relay shall have a final insulation resistance measurement of 10,000 megohms or greater.

3.6 Solderability (see 4.6.4). The critical (examination) area of solid wire lead and pin terminals shall be at least 95 percent covered with a continuous new solder coating in accordance with MIL-STD-202-208. For solder-lug terminals greater than .045 inch (1.14 mm) in diameter, 95 percent of the total length of fillet, which is between the standard wrap wire and the terminal, shall be tangent to the surface of the terminal being tested, and shall be free of pinholes, voids, etc. A ragged or interrupted line at the point of tangency between the fillet and the terminal under test shall be considered a failure.

3.7 Seal (see 4.6.5) The standard leak rate (L value in Eq. (1) of MIL-STD-883 Method 1014) shall be 1×10^{-6} atm cm³/s of air.

3.7.1 Reed relays. There shall be no evidence of leakage of air.

3.7.2 All other relays. There shall be no leakage in excess of 1×10^{-8} atmospheric cubic centimeters per second of air (atm cm³/s).

3.8 Insulation resistance (see 4.6.6). The insulation resistance shall be 10,000 megohms or more, unless otherwise specified (see 3.1). After the high level life tests, the insulation resistance shall be 1,000 megohms or more.

MIL-DTL-5757M

3.9 Dielectric withstanding voltage (see 4.6.7). There shall be no leakage current in excess of 100 microamperes (μA). After high level tests, the dielectric withstanding voltage measured at atmospheric or reduced barometric pressure shall be at least 75 percent of the initial value (see 3.1).

3.10 Electrical characteristics (see 4.6.8). The following tests as specified in 3.10.1 through 3.10.5 inclusive, shall comprise the electrical characteristics tests. Unless otherwise specified, electrical characteristics shall be 100 percent inspected and performed in the order as shown below.

3.10.1 Static contact resistance or contact voltage drop (see 4.6.8.1.1). Unless otherwise specified (see 3.1), the static contact resistance shall not exceed 0.05 ohm or equivalent contact voltage drop value.

3.10.2 Specified pickup, hold, and dropout values (voltages) (or current);(see 4.6.8.2). The specified pickup, hold, and dropout values (voltages) shall be as specified (see 3.1).

3.10.3 Coil resistance (or coil current) (see 4.6.8.3).

3.10.3.1 Coil resistance (or coil current) (see 4.6.8.3.1). The coil resistance (or coil current) shall be as specified (see 3.1).

3.10.3.2 Coil current (see 4.6.8.3.2). The coil current shall be as specified (see 3.1).

3.10.4 Operate and release time (see 4.6.8.3.3). The operate and release time shall be as specified (see 3.1). In multipole relays, during each of the operate and the release time measurements, the difference between the first moving contact to make and the last moving contact to make shall not exceed 1 millisecond (ms). This shall be exclusive of contact bounce. Release time is not applicable to latching relays.

3.10.4.1 Break before make (see 4.6.8.3.4). Moving contacts within a multipole relay shall show no evidence of any open contact closing before all closed contacts have opened (see 3.1). This applies to either state of the relay.

3.10.5 Contact dynamic characteristics (see 4.6.8.4).

3.10.5.1 Contact bounce (see 4.6.8.4.1). The duration of the contact bounce shall be as specified (see 3.1).

3.11 Thermal shock (see 4.6.9). Insulation resistance (3.8), specified pickup, hold, and dropout values (voltages)(3.10.2), and operate and release time (3.10.4) shall meet the specified requirements at each temperature extreme. Following the temperature excursions, there shall be no cracking, peeling, or flaking of the finish; dielectric withstanding voltage shall meet the requirements of 3.9.

3.12 Shock (specified pulse) (see 4.6.10). Unless otherwise specified (see 3.1), there shall be no opening of closed contacts in excess of 10 microseconds (μs) and there shall be no closure or bridging of open contacts in excess of 1 μs and no evidence of mechanical or electrical damage.

3.13 Vibration (see 4.6.11). Unless otherwise specified (see 3.1), there shall be no opening of closed contacts in excess of 10 μs and there shall be no closure or bridging of open contacts in excess of 1 μs and no evidence of mechanical or electrical damage.

3.14 Acceleration (unless otherwise specified, see 3.1) (see 4.6.12). The contacts of the relay shall remain in the de-energized position with no voltage across the coil and in the energized position when voltage is applied to the coil.

3.15 Terminal strength (see 4.6.13). There shall be no evidence of loosening or breaking of the terminals, nor shall there be any other damage which would adversely affect the normal operation of the relay. Bending of terminals shall not be construed as damage. The glass criteria of 3.28 does not apply here.

3.16 Magnetic interference (when specified, see 3.1) (see 4.6.14). The specified pickup, dropout, and hold values (voltages) shall meet the requirements specified in 3.10.2.

3.17 Contact sticking (when specified; see 3.1 and 4.6.15). When relays are tested as specified, the release time shall be as specified in 3.1.

MIL-DTL-5757M

3.18 Coil life (see [4.6.16](#)). There shall be no evidence of damage.

3.19 Resistance to soldering heat (see [4.6.17](#)). There shall be no damage which would adversely affect normal operation of the relay.

3.20 Salt spray or salt atmosphere (corrosion) (see [4.6.18](#)). There shall be no evidence of breaking, cracking, chipping, or flaking of the finish, nor exposure of the base metal, due to corrosion, which would adversely affect the application or performance characteristics of the relay.

3.21 Overload (applicable to high level relays only) (see [4.6.19](#)). The voltage drop across closed contacts shall be less than or equal to 5 percent of the applied load voltage and the voltage across open contacts shall be 95 percent or more of the applied load voltage. The case-to-ground fuse shall remain electrically continuous.

3.22 Life (see [4.6.20](#)). For low level testing, the contact miss detector's monitoring level shall be less than or equal to 100 ohms (unless otherwise specified, see [3.1](#)). For high level testing, the contact miss detector's monitoring level shall be less than or equal to 5 percent of the applied load voltage and the voltage across open contacts shall be 95 percent or more of the applied load voltage. Unless otherwise specified, the static contact resistance following cycling shall be no greater than twice the initial specified contact resistance requirement. There shall be no mechanical or electrical failure. Welding of contacts, failure to make, carry or break the load, or failure of the fuse connected between case and load system ground or neutral shall constitute a failure. Relays indicating failure, not verified in accordance with a failure verification procedure approved by the Qualifying Activity, may be returned to test. During post life tests, failure of a diode shall constitute a failure.

3.23 Intermediate current (see [4.6.21](#)). During cycling, unless otherwise specified (see [3.1](#)), the resistance of a closed contact shall be less than or equal to 3 ohms and the voltage across an open contact shall be 95 percent or more of applied load voltage. After cycling, the static contact resistance shall be measured at room ambient (+25°C) and shall not exceed the limits as specified (see [3.1](#)). Intermediate current shall not be considered a low level or high level contact load rating (see [6.1.1](#)). There shall be no mechanical or electrical failure. Welding of contacts, failure to make, carry or break the load, or failure of the fuse connected between case and load system ground or neutral shall constitute a failure. Relays indicating failure, not verified in accordance with a failure verification procedure approved by the qualifying activity, may be returned to test.

3.24 Mixed loads (applicable to high level relays only; see [3.1](#) and [4.6.22](#)). During cycling (unless otherwise specified) the dynamic contact resistance of a closed contact shall not exceed the applicable value specified. The voltage across an open contact shall be 95 percent or more of the applied load voltage. After cycling, the closed static contact resistance shall not exceed the limits specified.

3.25 Mechanical life (see [4.6.23](#)). After cycling, the insulation resistance and dielectric withstanding voltage shall not exceed the limits as specified (see [3.1](#)) and the operate and release time shall not exceed 120 percent of the limits specified (see [3.1](#)). There shall be no mechanical or electrical failure during or following cycling. Failure of the fuse connected between case and load system ground or neutral shall constitute a failure. The manufacturer's test system shall have the means to ensure that the required number of test cycles have been performed.

3.26 Resistance to solvents (see [4.6.24](#)). All markings shall remain legible after testing.

3.27 Marking (see [3.1](#) and [6.2](#)). Relays shall be marked in accordance with [MIL-STD-1285](#), with the following:

- a. Part or Identifying Number (PIN) (see [1.2](#)).
- b. Rated coil voltage or current.
- c. Coil resistance (or coil current) (see [3.10.3.1](#)).
- d. Contact rating (the highest dc resistive load rating shall be marked when plural loads are specified (see [3.4.3](#) and [3.1](#)).
- e. Circuit diagram (see [3.4.5](#)).
- f. Terminal identification (see [3.4.4.1](#)).
- g. Commercial and Government and date codes in accordance with [MIL-STD-1285](#).

MIL-DTL-5757M

3.27.1 Interchangeability. All parts having the same military PIN shall be directly and completely interchangeable with each other with respect to installation and performance to the extent specified in the specification sheet (see 3.1).

3.28 Header glass. Header glass may have small irregularities, such as bubbles, chips, and cracks. The acceptability shall be based on figure 4 and the following:

- a. Surface blisters whose diameters do not exceed one-half of the radial distance between the terminal and the corresponding header metal are acceptable (for a cluster of blisters, the overall cluster diameter shall apply).
- b. Circumferential cracks which originate and terminate in the glass and which extend less than 135° are acceptable (see figure 4, reference B).
- c. Radial cracks with lengths not exceeding three-quarters of the distance between the terminal and the surrounding header metal are acceptable (see figure 4, reference C).
- d. Tangential cracks which are confined to a single zone are acceptable (see figure 4, reference D).
- e. Meniscus cracks and chipouts which completely surround the terminal are acceptable if:
 - (1) The meniscus cracks and chipouts do not extend beyond one-half the distance from the terminal to the surrounding header metal, or
 - (2) The meniscus cracks and chipouts do not extend beyond one-quarter of the distance from the terminal to the surrounding header metal and a portion of the meniscus cracks and chipouts does not extend beyond three-quarters of the distance from the terminal to the surrounding header metal if that portion of the meniscus cracks and chipouts does not span more than 180° (see figure 4, reference E).
- f. An internal bubble whose diameter does not exceed one-third the distance between the terminal and the surrounding header metal is acceptable.

Microscopic examination with up to 10X magnification shall be used. In case of dispute, all relays shall meet the applicable insulation resistance, dielectric withstanding voltage, and seal requirements, regardless of the acceptability of the header glass.

The above requirements are not applicable after group B and group C inspections.

3.29 Workmanship. Relays shall be uniform in quality and shall be free of cracked or displaced parts, sharp edges, burrs, and other defects that could affect their life, serviceability, or appearance.

4. VERIFICATION

4.1 Classification of inspections. The inspection requirements specified herein are classified as follows:

- a. Qualification inspection (see 4.3).
- b. Verification of qualification (see 4.4 and 4.4.1).
- c. Conformance and periodic inspections (see 4.5).

4.2 Inspection conditions. Unless otherwise specified, all inspections shall be performed in accordance with the test conditions specified in the "GENERAL REQUIREMENTS" of MIL-STD-202. All inspections may be performed at ambient environmental conditions consistent with industry practice.

4.2.1 Power supply. Unless otherwise specified herein, the power supply shall have no more than 10 percent regulation at 110 percent of the specified test load current. A dc power supply shall have no more than 5 percent ripple voltage. An ac power supply shall be within 1 percent of the specified frequency and shall be sinusoidal with a form factor between 0.95 and 1.25.

MIL-DTL-5757M

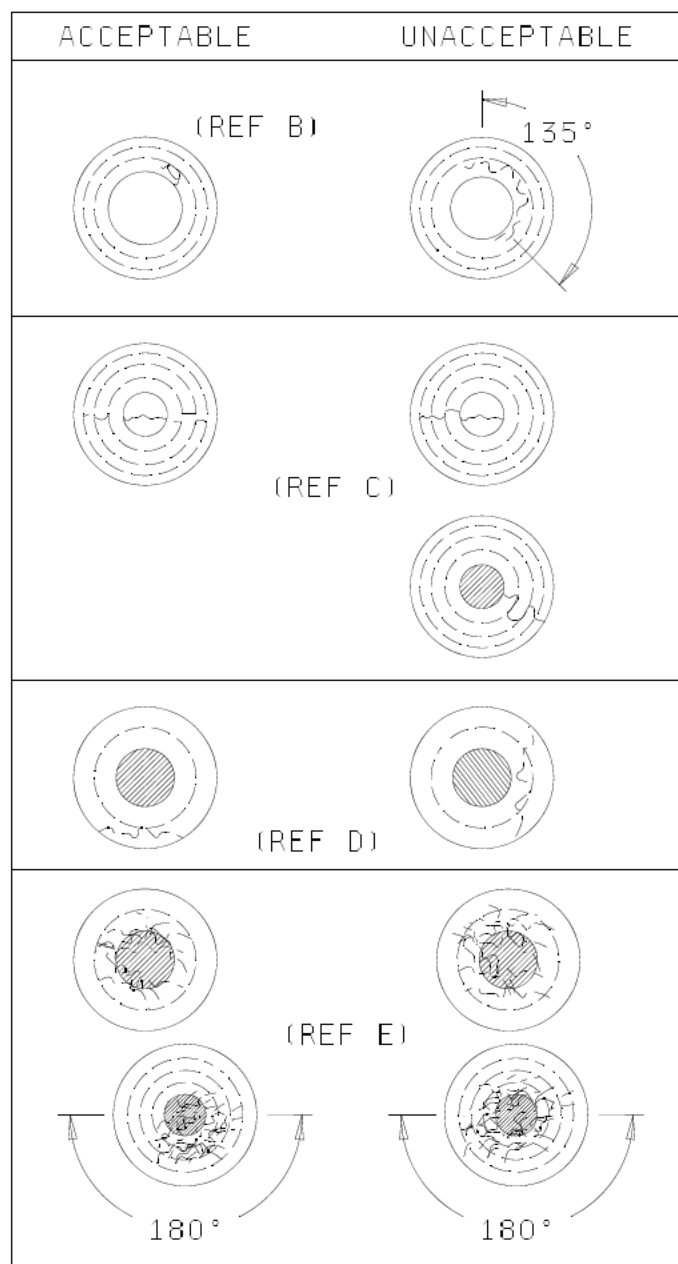

NOTE: The broken lines indicate the division of the radial distance between the terminal and the surrounding header metal into equal parts, thus creating concentric zones around the terminal.

FIGURE 4. Header inspection aid.

MIL-DTL-5757M

4.2.2 Grounding. Unless otherwise specified (see 3.1), the negative side of the dc power supply shall be grounded. One side of single phase ac power supply shall be grounded.

4.2.3 Load conditions during tests. The coil(s) of the relay under test shall have one side connected to the coil power supply ground. All tests during which the contacts are loaded and being cycled, except dielectric withstanding voltage, shall be conducted with the case of the relay connected to the power supply ground or neutral through a normal blow fuse rated at 5 percent of the contact load maximum, but not less than 0.100 ampere. For relays with nongrounded case ratings, tests for isolated-case ratings may be made with the case electrically isolated from the power supply ground.

4.2.4 Testing devices. Devices used in the testing of relays shall not load the contacts above 10 milliamperes (mA) resistive at 6 V dc or peak ac maximum open circuit unless otherwise specified herein.

4.2.5 Mounting relays for ambient temperature tests. When the relays are subjected to the testing specified in 4.6.16 (coil life) and 4.6.22 (mixed loads), they may be mounted on a heat sink in accordance with the following:

- a. Each relay may be attached by its normal mounting means to a .063 inch (1.59 mm) thick minimum, flat aluminum plate heat sink. The heat sink shall be designed to place every relay in the center of its own square space whose total surface area (both sides) is eight times the outside surface area of the relay, excluding mounting. Relays without mounts shall be held to the heat sink with a metal strap .250 inch (6.35 mm) wide by .015 inch (0.38 mm) maximum thickness. The heat sink assembly shall be suspended by twine or other nonheat conducting material. The leads shall not constitute a heat sink.
- b. Chamber temperature shall be controlled to maintain the temperature at the specified ambient extremes (see 3.1).

4.2.6 Methods of examination and test. Application of coil power to relays under test shall be such that plus polarity is applied to the color coded terminal when applicable; or to the lower numbered terminal when color coding is not used.

4.2.7 Tolerances. Unless otherwise specified (see 3.1), all electrical, environmental, and mechanical parameters shall have a tolerance of ± 10 percent.

4.2.8 Alternate test equipment. Test circuits and test equipment herein are intended to provide guidance to the relay manufacturer. Use of any alternate test circuits and/or test equipment shall be approved by the qualifying activity prior to use.

4.2.9 Test equipment and inspection facilities. The manufacturer shall establish and maintain a calibration system in accordance with NCSL Z540.3, ISO-10012, or equivalent system as approved by the qualifying activity.

4.3 Qualification inspection. Qualification inspection shall be performed at a laboratory acceptable to the Government (see 6.3) on sample units produced with equipment and procedures normally used in production.

4.3.1 Qualification. A certification of construction to the materials requirements of 3.3, and the interface and construction requirements of 3.4 shall accompany the submission of qualification inspection results to the qualifying activity.

4.3.1.1 Sample size. The number of relays to be subjected to qualification inspection shall be as specified in table I. The sample shall be selected from a production run and shall be produced with equipment and procedures normally used in production. The qualification sample shall be as defined in table I.

4.3.2 Inspection routine. Sample units shall be subjected to qualification inspection outlined in table I, in the order shown, except that group Q2 through group Q7 inclusive, may be conducted concurrently. All sample units shall be subjected to the inspections of Q1. These sample units shall then be divided into six groups as specified in table I and subjected to the inspection specified for their particular group.

4.3.3 Failures. Failures in excess of those allowed in table I shall be cause for refusal to grant qualification approval.

MIL-DTL-5757M

TABLE I. Qualification inspection.

Inspection	Requirement paragraph	Test method paragraph	Number of sample units to be inspected	Number of failures allowed
<u>Q1</u>				
Visual and mechanical inspection (internal) <u>1/</u>	3.1, 3.27 and 3.28	4.6.1	All sample units	0
Screening	3.5	4.6.2, 4.6.3		
Solderability (3 sample units) <u>2/</u>	3.6	4.6.4		
Dielectric withstanding voltage <u>3/</u>	3.9	4.6.7		
Insulation resistance <u>3/</u>	3.8	4.6.6		
Electrical characteristics <u>3/</u>	3.10	4.6.8		
Visual and mechanical inspection (external) (dimensional check on 2 sample units only)	3.1,3.27, and 3.29	4.6.1		
Seal	3.7	4.6.5		
<u>Q2</u>				
Thermal shock	3.11	4.6.9	4	1
Resistance to solvents	3.26	4.6.24		
Shock (specified pulse)	3.12	4.6.10		
Vibration (sinusoidal)	3.13	4.6.11.1		
Vibration (random)	3.13	4.6.11.2		
Acceleration	3.14	4.6.12		
Terminal strength	3.15	4.6.13		
Dielectric withstanding voltage <u>3/</u>	3.9	4.6.7		
Insulation resistance <u>3/</u>	3.8	4.6.6		
Electrical characteristics <u>3/</u>	3.10	4.6.8		
Seal	3.7	4.6.5		
<u>Q3</u>				
Magnetic interference (when specified)	3.16	4.6.14	4	1
Coil life	3.18	4.6.16		
Resistance to soldering heat	3.19	4.6.17		
Salt atmosphere (corrosion)	3.20	4.6.18		
Dielectric withstanding voltage <u>3/</u>	3.9	4.6.7		
Insulation resistance <u>3/</u>	3.8	4.6.6		
Electrical characteristics <u>3/</u>	3.10	4.6.8		
Seal	3.7	4.6.5		

See footnotes at end of table.

MIL-DTL-5757M

TABLE I. Qualification inspection - Continued.

Inspection	Requirement paragraph	Test method paragraph	Number of sample units to be inspected	Number of failures allowed
<u>Q4</u> Overload (highest dc resistive load) Life (highest rated dc, 50,000 cycles) Dielectric withstanding voltage <u>3/</u> Insulation resistance <u>3/</u> Electrical characteristics <u>3/</u>	3.21 3.22 3.9 3.8 3.10	4.6.19 4.6.20 4.6.7 4.6.6 4.6.8	4	1
<u>Q5</u> Life Dielectric withstanding voltage <u>3/</u> Insulation resistance <u>3/</u> Electrical characteristics <u>3/</u>	3.22 3.9 3.8 3.10	4.6.20 4.6.7 4.6.6 4.6.8	see <u>1/</u>	0
<u>Q6</u> Intermediate current Dielectric withstanding voltage <u>3/</u> Insulation resistance <u>3/</u> Electrical characteristics <u>3/</u>	3.23 3.9 3.8 3.10	4.6.21 4.6.7 4.6.6 4.6.8	4	1
<u>Q7</u> Mechanical life Dielectric withstanding voltage Insulation resistance Operate and release time Visual inspection (external)	3.25 3.9 3.8 3.10.4 3.1, 3.27, 3.28, 3.29	4.6.23 4.6.7 4.6.6 4.6.8.4 4.6.1	4	1

1/ One sample unit remaining unsealed shall be subjected to the internal inspection.

2/ Solderability samples are not subjected to dielectric withstanding voltage, insulation resistance, electrical characteristics, and seal.

3/ Coil resistance (or coil current) may be done prior to dielectric withstanding voltage and insulation resistance. Testing sequence is optional for insulation resistance and dielectric withstanding voltage prior to electrical characteristics.

4/ A minimum of four relays shall be tested for Q5. For relays with more than two contact ratings, two relays per contact rating shall be tested.

MIL-DTL-5757M

4.4 Verification of qualification. The contractor shall forward to the qualifying activity at 12-month intervals a verification of group A inspections and the results of group B tests. At 36-month intervals, a Group C verification shall be provided. The qualifying activity shall establish the initial reporting period. The verification shall consist of:

- a. The results of tests performed for inspection of product for delivery, group A, indicating as a minimum the number of lots that have passed and the number that have failed. The results of the testing of all reworked lots shall be identified and accounted for.
- b. The results of the tests performed for the quarterly inspection, group B, including the number and mode of failures including the results of all quarterly inspection tests performed and completed for the 12-month maintenance period. If, at any time during this period, the test results indicate nonconformance with specification requirements, the manufacturer shall suspend all shipments of the affected product and shall notify the qualifying activity within five working days with a failure mode. Failure to notify the qualifying activity within five working days may result in removal from the QPL.

4.4.1 Failure to provide verification. Should the contractor fail to provide verification within 60 days after the end of each 12-month or 36-month period may result in loss of qualification for that product. In addition, the contractor shall notify, within five working days, the qualifying activity of either of the following conditions:

- a. After the first six months of the 12-month inspection period, the lot rejection for group A inspection exceeds 20 percent or two lots, whichever is greater, or;
- b. During the 12-month and/or 36-month period that the group B or group C inspection indicates failure of the qualified product to meet the requirements of this specification.

If any of the above conditions exist, the manufacturer shall suspend shipment pending acceptance of any failure analysis or corrective action by the qualifying activity.

4.5 Conformance and periodic inspections.

4.5.1 Conformance inspection.

4.5.1.1 Inspection of product for delivery. Inspection of product for delivery shall consist of group A inspection.

4.5.1.1.1 Inspection and production lot.

4.5.1.1.1.1 Inspection lot. An inspection lot shall consist of all the relays of the same specification sheet, and those of similar design and construction, manufactured under essentially the same processes and conditions during a manufacturing period of 1 month maximum. The manufacturer shall define the period for an inspection lot. For purposes of lot formation, all terminal types and mounting configurations may be combined.

4.5.1.1.1.2 Production lot. A production lot shall consist of all relays of the same PIN. Manufacture of all parts in the lot shall have been started, processed, assembled, and tested as a group. Lot identity shall be maintained throughout the manufacturing cycle.

4.5.1.2 Group A inspection. Group A inspection shall consist of the inspections specified in [table II](#).

4.5.1.2.1 A1, A2, and A4 tests. The A1, A2, and A4 tests shall be performed on a production lot basis on 100 percent of the product supplied under this specification, except as noted. Relays that do not meet specification requirements of these groups shall be removed from the lot.

4.5.1.2.1.1 Sampling plan. The tests in A1, A2, and A4 shall be performed on each relay offered for inspection, except as noted.

4.5.1.2.1.2 Rejected lots. Relays that do not meet the requirements of the tests in A1 and A4 shall be rejected and shall be removed from the lot. If more than 5 percent of the relays are discarded during A2 testing, the production lot shall be rejected and not offered for reinspection.

MIL-DTL-5757M

4.5.1.2.2 A3 tests.

4.5.1.2.2.1 Sampling plan. Two samples shall be selected randomly from each inspection lot and subjected to the A3 solderability test. If there are one or more defects, the lot shall be considered to have failed. Relays failing the A2 electrical tests, or rejected for other criteria which will not influence solderability, may be used for solderability testing. All rejected relays used as samples must accompany the acceptable relays through all processing environments. The rejected relays shall be marked in a definite manner in order to preclude mixing with acceptable parts.

4.5.1.2.2.2 Rejected lots. In the event of one or more defects, the inspection lot is rejected. The manufacturer may use one of the following options to rework the lot:

- a. Each production lot that was used to form the failed inspection lot shall be individually submitted to the solderability test as required in 4.6.4. Production lots that pass the solderability test are acceptable for shipment after successful completion of group A4. Production lots failing the solderability test may be reworked as described in 4.5.1.2.2.2b and 4.5.1.2.2.2c.
- b. The manufacturer submits the failed lot to a 100 percent solder dip using an approved solder dip process in accordance with 3.4.7.5. Two additional samples shall be selected and subjected to the solderability test with zero defects allowed. If the lot fails this solderability test, the lot shall be rejected and shall not be furnished against the requirements of this specification.
- c. The manufacturer may submit the failed lot to a strip and replate process followed by a complete group A inspection. The reworked lot shall be considered a new lot for the purpose of the 5 percent requirement of A2. If the lot fails this solderability test, the lot shall be rejected and shall not be furnished against the requirements of this specification.

TABLE II. Group A inspection.

Inspection <u>1/</u>	Requirement paragraph	Test method paragraph	Inspection requirements
<u>A1</u> Screening, internal moisture Screening, run-in	<u>3.5</u> <u>3.5</u>	<u>4.6.2</u> <u>4.6.3</u>	Internal moisture; run-in <u>2/</u>
<u>A2</u> Dielectric withstanding voltage <u>3/</u> Insulation resistance <u>3/</u> Electrical characteristics <u>3/</u>	<u>3.9</u> <u>3.8</u> <u>3.10</u>	<u>4.6.7</u> <u>4.6.6</u> <u>4.6.8</u>	100 percent
<u>A3</u> Solderability	<u>3.6</u>	<u>4.6.4</u>	2 samples
<u>A4</u> Visual and mechanical inspection (external) <u>4/</u> Seal	<u>3.1, 3.27, 3.28</u> <u>3.7</u>	<u>4.6.1</u> <u>4.6.5</u>	100 percent

1/ Except as noted in 3/, tests shall be performed in the order shown.

2/ Thirteen relays shall be tested. If there are any failures, the entire lot shall be tested for internal moisture.

3/ Testing sequence is optional for insulation resistance, dielectric withstanding voltage, and coil resistance/maximum coil current only.

4/ Minor defects, such as marking, may be reworked. A two piece sample from each lot shall be mechanically inspected.

MIL-DTL-5757M

4.5.2 Periodic inspections. Periodic inspections shall consist of group B and group C. Except where the results of these inspections show noncompliance with the applicable requirements, delivery of products which have passed group A shall not be delayed pending the results of these periodic inspections.

4.5.2.1 Group B inspection. Group B inspection shall consist of the tests specified in [table III](#) and shall be made on sample units which have been subjected to and have passed the group A inspection.

4.5.2.1.1 Sampling plan. Four sample units shall be selected every three months from the inspection lots which have passed group A inspection. No failures are allowed.

4.5.2.1.2 Disposition of sample units. Sample units which have been subjected to group B inspection shall not be delivered on the contract or order.

TABLE III. Group B inspection.

Inspection	Requirement paragraph	Test method paragraph
Vibration	3.13	4.6.11
Mixed loads 1/	3.24	4.6.22
Dielectric withstanding voltage 2/	3.9	4.6.7
Insulation resistance 2/	3.8	4.6.6
Electrical characteristics 2/	3.10	4.6.8
Visual inspection (external)	3.1 , 3.27 , 3.29	4.6.1

[1/](#) When intermediate current is not applicable, low level testing, as specified, shall be performed in accordance with the life test (see [3.22](#)), using procedure [4.6.20.4](#) only; otherwise, use procedure [4.6.20.1](#) only for maximum rated resistive current.

[2/](#) Testing sequence is optional for insulation resistance, dielectric withstanding voltage, and coil resistance (or coil current) only.

4.5.2.2 Group C inspection. Group C inspection shall consist of the inspections specified in [table I](#) (qualification table) in the order shown. Group C inspection shall be made on sample units selected from inspection lots which have passed the group A inspection.

4.5.2.2.1 Sampling plan. Every 36 months, the number of sample units specified in [4.3.1.1](#) shall be subjected to the inspections of [table I](#), performed in the order shown. The number of failures allowed shall be as specified in [table I](#).

4.5.2.2.2 Disposition of sample units. Sample units which have been subjected to group C inspection shall not be delivered on the contract or order.

4.5.2.3 Noncompliance. If any sample fails group B, or if the number of group C failures exceeds the number of failures allowed in [table I](#), the manufacturer shall notify the qualifying activity and the cognizant inspection activity of such failure, and shall take corrective action on the materials or processes, or both, as warranted, and on all units of product which can be corrected and which were manufactured with essentially the same materials and processes, and which are considered to be subject to the same failure. Acceptance and shipment of the product shall be discontinued until corrective action acceptable to the qualifying activity has been taken. After the corrective action has been taken, group C inspection shall be repeated on additional sample units (all inspections or the specific inspection which the original sample failed, at the option of the qualifying activity). Group A and group B inspections may be reinstated; however, final acceptance and shipment shall be withheld until the group C inspection has shown that the corrective action was successful. In the event of failure after reinspection, information explaining the failure shall be furnished to the cognizant inspection activity and the qualifying activity.

MIL-DTL-5757M

4.6 Methods of inspection.

4.6.1. Visual and mechanical. Relays shall be examined to verify that the materials (see 3.3), interface and construction (see 3.4), physical dimensions (required only where mechanical inspection is specified), marking (see 3.27), header glass (see 3.28), and workmanship (see 3.29) are in accordance with the applicable requirements. Inspection requirements apply only where indicated (see 3.28).

4.6.2. Internal moisture (when specified; see 3.1, 3.5). Relays (coils de-energized) shall be held at 15°C to 25°C for a minimum of 30 minutes. The insulation resistance of all contact pins, to case only, shall be observed and measured. The relay coil shall be energized with 140 percent of rated voltage (or current) for a period of two and one-half minutes. The insulation resistance of all contact pins, to case only, shall be verified a minimum of once each 30 seconds during this period. The lowest value shall meet the requirements of 3.5.

4.6.3. Run-in (when specified; see 3.1, 3.5). Relays shall be subjected to 5,000 operations.

$$\text{Maximum cycle rate (cycles per second)} = \frac{0.1}{\text{Maximum operate time (seconds)} + \text{Maximum release time (seconds)}}$$

The following conditions apply:

- a. Room ambient temperature (25°C).
- b. The coil shall be energized at rated voltage (or current) (see 3.1).
- c. Each pair of mated contacts shall be monitored for dynamic contact resistance.
- d. The load conditions shall be at low level, unless otherwise specified.

4.6.4. Solderability (see 3.6). Relays shall be tested in accordance with MIL-STD-202-208. The following detail and exception shall apply: All terminations of each part shall be tested.

4.6.5. Seal (see 3.7). Relays shall be tested in accordance with 4.6.5.1, as applicable. In case of dispute, method 1014 of MIL-STD-883, test condition B shall govern.

4.6.5.1. Relays sealed with or without a tracer gas. Relays shall be tested for fine leak and gross leak using one of the fine leak procedures and one of the gross leak procedures in the following table. Fine leak shall be performed prior to gross leak, unless MIL-STD-883 (method 1014) Test Condition B₂/B₁ is used. The standard leak rate (L value in Eq. (1) of MIL-STD-883 Method 1014) shall be 1 X 10⁻⁶ atm cm³/s of air.

Fine Leak
MIL-STD-883 (method 1014) – Test Condition B ₁
MIL-STD-883 (method 1014) – Test Condition A ₂
Gross Leak
MIL-STD-883 (method 1014) – Test Condition B ₂
MIL-STD-202-112 – Test Condition D
MIL-STD-883 (method 1014) – Test Condition C
Fine Leak and Gross Leak Combination
MIL-STD-883 (method 1014) – Test Condition B ₂ /B ₁
When using the radioisotope tests, it is recommended practice to use B ₂ first to remove gross leakers prior to the fine leak test B ₁ , which minimizes the Kr85 entrapped in rejected devices.

MIL-DTL-5757M

4.6.6 Insulation resistance (see 3.8). Relays shall be tested in accordance with MIL-STD-202-302 with the relay in the energized and de-energized (latch/reset) positions. The following details shall apply unless otherwise specified (see 3.1):

- a. Test conditions: A (for relays with coil and contact ratings both below 60 volts) and B (for all other relays).
- b. Points of measurement: As specified in points of application in table IV.
- c. Attributes data is acceptable.

4.6.7 Dielectric withstanding voltage (see 3.9). Relays shall be tested as specified in 4.6.7.1 and 4.6.7.2. Testing in accordance with 4.6.7.2 is not required for group A testing.

4.6.7.1 At atmospheric pressure. Relays shall be tested in accordance with MIL-STD-202-301. The following details shall apply unless otherwise specified (see 3.1):

- a. Points of application and magnitude of test voltage: As shown in table IV.
- b. Maximum leakage current: 100 mA.
- c. Duration of application: Sixty seconds minimum for qualification and group B and group C tests; 5 cycles (60 Hz) minimum for group A tests on test equipment which has an adequate response time to measure the leakage current and is approved by the qualifying activity. For group A tests on other than automatic test equipment (i.e., bench setup), the application time shall be 5 seconds minimum.
- d. Attributes data is acceptable.

TABLE IV. Test details for dielectric withstanding voltage.

Points of application	Test voltage
Between case, frame, or enclosure and between all contacts in the energized and de-energized positions Between case, frame, or enclosure and coil(s) Between all contacts and coil(s) Between open contacts in the energized and de-energized positions Between contact poles in the energized and de-energized positions (applicable to multipole relays)	1,000 percent \pm 5 percent volts ac plus twice rated voltage (or current) or the specified value \pm 5 percent

MIL-DTL-5757M

4.6.7.2 At reduced barometric pressure. Relays shall be tested in accordance with [MIL-STD-202-105](#). The following details shall apply:

- a. Method of mounting: Normal mounting means.
- b. Test condition: C.
- c. Tests during subjection to reduced pressure: As specified in [4.6.7.1](#), except test voltage shall be 350 V rms unless otherwise specified (see [3.1](#)).
- d. Points of application of test voltage: All terminals to case.
- e. Duration of application: 60 seconds minimum for qualification and group B and group C tests.
- f. Attributes data is acceptable.

4.6.8 Electrical characteristics (see [3.10](#)).

4.6.8.1 Static contact resistance or contact voltage drop (see [3.10.1](#)). The static contact resistance or static contact voltage drop shall be required for each pair of contacts. If both contact voltage drop and static contact resistance are specified in the documents the manufacturer has the choice of which to run for the contacts. However, each contact must be tested.

4.6.8.1.1 Static contact resistance (see [3.10.1](#)). Relays shall be tested in accordance with [MIL-STD-202-307](#). The following details and exception shall apply:

- a. Method of connection: The point of measurement shall be on leads external to the case. Suitable jigs and fixtures shall be used.
- b. Test load: Test current shall be 100 mA at a voltage equal to or below rated voltage, except those rated for low level. See [6.1.1](#) for low level voltage rating. For low level, the current shall be 10 mA maximum. (dc or peak ac).
- c. Post test current: Load current and voltage shall be 100 mA maximum at a voltage equal to or below rated voltage, unless life tests are specified in the grouping. When life tests are specified in the grouping, the same current at a maximum of rated voltage as the life test, or 100mA maximum at 28vdc maximum, shall be used.
- d. Points of measurements:
 - (1) Between all normally closed mated contacts.
 - (2) Between all normally open mated contacts, with the coil energized with rated coil voltage (or current) for non-latch type relays, or in the latch/reset position for magnetic latch type relays, with or without coil energized.
- e. Number of activations prior to measurement: During static resistance tests, the number of activation prior to measurement is none.
- f. Number of test activations: Maximum of three activations in each closed contact position for qualification Q1. For all remaining groups in the Qualification table, group A, group B, and group C, one activation in each closed contact position.
- g. Number of measurements per activation: One in each closed contact position. The readings shall be taken after the circuit has stabilized and within a maximum time of 10 seconds after activation.

MIL-DTL-5757M

4.6.8.1.2 Contact voltage drop (see 3.10.1). Relays shall be tested in accordance with [MIL-STD-202-307](#). The following details and exception shall apply:

- a. Method of connection: The point of measurement shall be on leads external to the case. Suitable jigs and fixtures shall be used.
- b. Test load: Test current shall be rated resistive current at rated voltage or less. See [6.1.1](#) for low level voltage rating. If a lower test current is used, the millivolt drop shall be adjusted according to Ohm's law.
- c. Post test loads for intermediate current and life: When intermediate current is specified in the grouping, the same current as intermediate current, or 100 mA, at a voltage equal to or below rated voltage shall be used. When life tests are specified in the grouping, the same current as the high level life test, or 100 mA, at a voltage equal to or below rated voltage shall be used. If a lower test current is used, the millivolt drop shall be adjusted according to Ohm's law.
- d. Points of measurements:
 - (1) Between all normally closed mated contacts.
 - (2) Between all normally open mated contacts, with the coil energized with rated coil voltage (or current) for non-latch type relays, or in the latch/reset position for magnetic latch type relays, with or without coil energized.
- e. Number of activations prior to measurement: During contact voltage drop tests, the number of activation prior to measurement is none.
- f. Number of test activations: Maximum of three activations in each closed contact position for qualification Q1. For all remaining groups in the Qualification table, group A, group B, and group C, one activation in each closed contact position.
- g. Number of measurements per activation: One in each closed contact position. The readings shall be taken after the circuit has stabilized and within a maximum time of 2 seconds after activation.

4.6.8.2 Specified pickup, hold, and dropout values (voltages) (or current) (see 3.10.2). Specified pickup, hold, and dropout values (voltage) shall be measured as specified in [4.6.8.2.1](#), [4.6.8.2.2](#), or [4.6.8.2.3](#). For qualification inspection, the relay shall be mounted in each of three mutually perpendicular planes, unless otherwise specified (see [3.1](#)). For quality conformance inspection, mounting position is optional. A suitable indicating device shall be used to monitor contact position. During the test, all contacts shall not change state (break or remake) when the coil is energized at or above the specified pickup value (voltage); when the coil voltage (or current) is lowered to any value at or above specified hold value (voltage); or when the coil voltage (or current) is reduced from the specified dropout value (voltage) to zero. It is permissible to perform specified pickup, hold, and dropout values (voltages) using step function voltage changes as specified in [4.6.8.2.1](#), [4.6.8.2.2](#), and [4.6.8.2.3](#). Due to the fact that slow ramping will overheat relay coils and vary specified pickup, hold, and dropout values (voltages), the step function method shall be the governing method in cases of dispute.

MIL-DTL-5757M

4.6.8.2.1 Specified pickup value (voltage). The voltage shall be increased from zero until the relay operates, and the specified pickup value (voltage) shall be measured. It is permissible to perform specified pickup value (voltage) using a step function voltage change as follows and as illustrated on [figure 6](#).

- a. Step up to the maximum specified pickup value (voltage), contacts should have transferred and all normally-open contacts should be made.
- b. Increase to rated coil voltage (or current).
- c. Step down to specified hold value (voltage). Normally-open contacts must still be making.
- d. Step down to specified dropout value (voltage), all contacts should have transferred and all normally-closed contacts should be making.
- e. Step down to zero voltage.

4.6.8.2.2 Specified hold value (voltage). Rated voltage (or current) shall be applied to the coil. The voltage shall then be reduced to the specified hold value (voltage) (see [3.1](#) and [6.8](#)). All contacts shall not change state. It is permissible to perform this test using the step function voltage program described in [4.6.8.2.1](#) and [figure 6](#).

4.6.8.2.3 Specified dropout value (voltage). Rated voltage (or current) shall be applied to the coil. The voltage shall then be gradually reduced until all contacts return to the de-energized position and the specified dropout value (voltage) shall be measured. It is permissible to perform this test using the step function voltage program described in [4.6.8.2.1](#) and [figure 6](#).

4.6.8.3 Coil resistance (or coil current) (see [3.10.3](#)).

4.6.8.3.1 Coil resistance (or coil current) (see [3.10.3.1](#)). Relay coils shall be tested in accordance with [MIL-STD-202-303](#).

4.6.8.3.2 Coil current (when specified, see [3.10.3.2](#)). When rated voltage (or current) is applied to the coil terminals, the current must be within the limits as specified (see [3.1](#)). Apply rated voltage (or current) for 5 seconds maximum.

4.6.8.3.3 Operate and release time (see [3.10.4](#)). Operate and release time of all contacts shall be measured using an oscilloscope or other acceptable means approved by the qualifying activity. Rated voltage (or current) shall be applied to the coil. Contact load conditions shall be 6 V dc maximum or peak ac at 10 mA maximum. The circuit shown on [figure 6](#), or equivalent, shall be used. The operate and release time shall be exclusive of contact bounce or contact stabilization time. Timing measurements shall be made on all contact sets. Release time is not applicable to latching relays.

4.6.8.3.4 Break before make (see [3.10.4.1](#)). The circuit shown on [figure 7](#), or an equivalent circuit approved by the qualifying activity shall be used to monitor contact position.

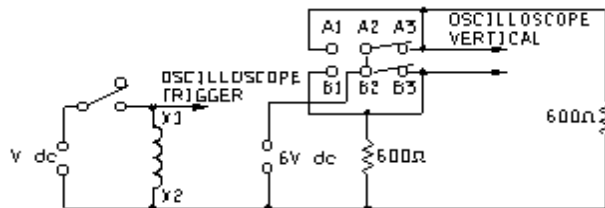

FIGURE 5. Typical break before make test circuits.

MIL-DTL-5757M

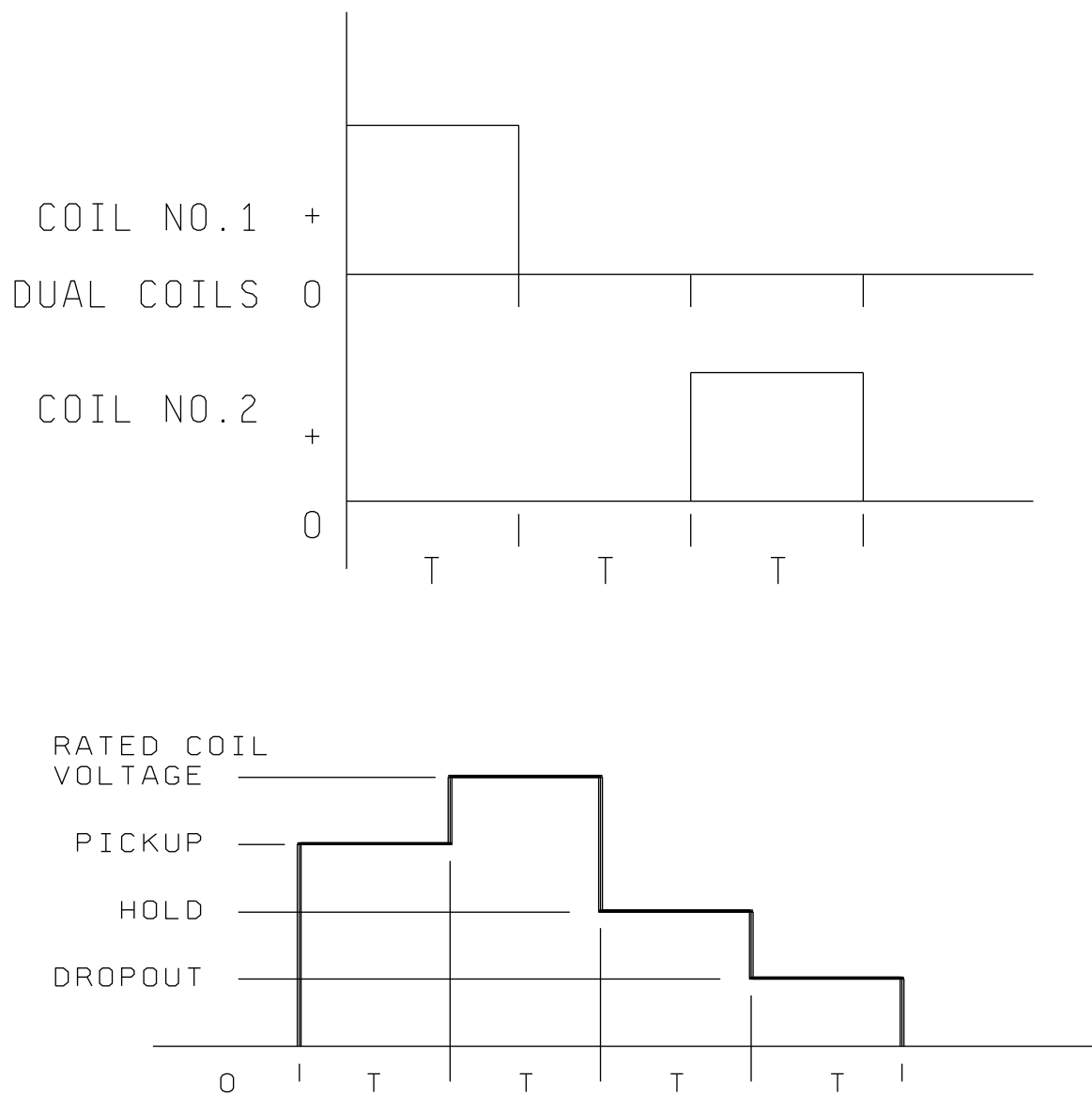

FIGURE 6: Pickup, hold, and dropout sequencing.

MIL-DTL-5757M

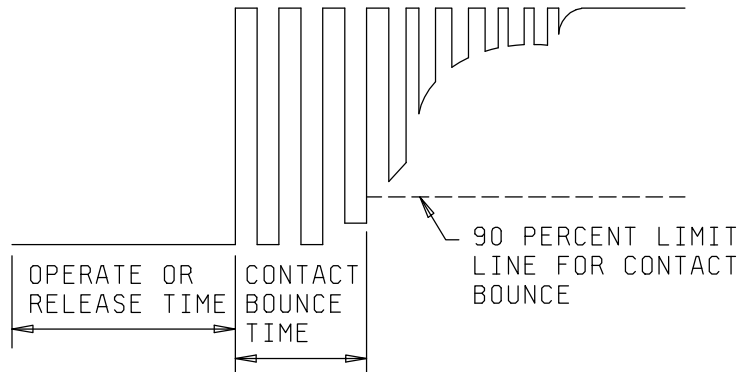
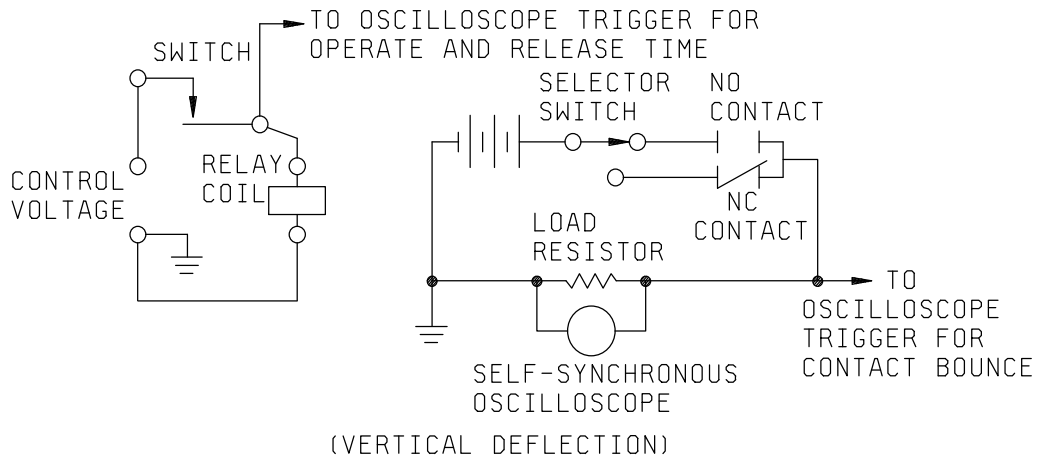

FIGURE 7. Typical circuit for operate and release time, contact bounce, and contact stabilization time with typical traces.

MIL-DTL-5757M

4.6.8.4 Contact dynamic characteristics (see 3.10.5).

4.6.8.4.1 Contact bounce (see 3.10.5.1). Contact bounce shall be measured on each contact set using an oscilloscope or other acceptable means approved by the qualifying activity. The trace shall show contact switching at operate and release and appropriate timing markers when using an oscilloscope. Rated voltage (or current) shall be applied to the coil. Contacts shall be loaded with 6 V dc maximum or peak ac at 10 mA maximum. After high level rated load life and intermediate current tests, contact bounce shall be measured at 100 mA maximum at 28 V dc maximum. A contact bounce shall be considered any occurrence equal to or greater than 90 percent of the open circuit voltage with a pulse width of 10 μ s or greater. The circuit shown on [figure 7](#), or equivalent, shall be used.

4.6.9 Thermal shock (see 3.11). Relays shall be tested in accordance with [MIL-STD-202-107](#). The following details and exceptions shall apply:

- a. Special mounting: Relays shall be suspended in the test chamber by twine, test socket, or other nonheat-conducting material. Test leads may be used for mounting; however, they shall not exceed the diameter or cross section of the device lead. (NOTE: When test sockets are used, the surface of the header shall not directly contact with the surface of the socket and the leads of the socket shall not exceed the diameter or cross section of the device lead).
- b. Test condition: B, except exposure time at temperature extreme during the fifth cycle shall be for 2 hours each.
- c. Measurements at each temperature extreme during step 1 and step 3 of this fifth cycle at the end of each temperature exposure, and with the relays still in the conditioning chamber, the insulation resistance ([4.6.6](#)), specified pickup and dropout values (voltages) ([4.6.8.2](#)), and operate and release time ([4.6.8.4](#)), shall be measured as specified. Specified pickup and dropout values (voltages) shall be measured in any position.
- d. Examination after test: Relays shall be visually examined for cracking, peeling, and flaking of the finish, and the dielectric withstanding voltage shall then be measured as specified in [4.6.7.1](#).

4.6.10 Shock (specified pulse) (see 3.12). Unless otherwise specified (see [3.1](#)), relays shall be tested in accordance with [MIL-STD-202-213](#). The following details and exceptions shall apply:

- a. Mounting method: For relays having flanges or studs, mounting shall be by the flanges or studs; and for relays without flanges, mounting shall be by plugging into sockets, or other suitable means approved by the qualifying activity.
- b. Test condition: A, B, or C, as applicable (see [3.1](#)).
- c. Electrical-load conditions: In each direction of shock, the coil shall be de-energized during two shocks and energized with rated voltage (or current) during one shock.
- d. Measurements during shock: Contacts shall be monitored with an adequate test circuit as approved by the qualifying activity. The test circuit shall verify that no opening of closed contacts in excess of 10 μ s and no false closure or bridging of open contacts occurs in excess of 1 μ s. The contact load shall be 10 mA maximum at 6 V maximum (dc or peak ac).
- e. Examination after test: Relays shall be examined for evidence of structural failure or other damage which might impair the operation of the relay.

MIL-DTL-5757M

4.6.11 Vibration (see 3.13).

4.6.11.1 Vibration (sinusoidal). Unless otherwise specified (see 3.1), relays shall be tested in accordance with MIL-STD-202-204. The following details and exceptions shall apply:

- a. Method of mounting: As specified in 4.6.10a.
- b. Electrical-load conditions: For qualification and group C inspections, relays shall be tested with the coil energized for 2 hours at rated voltage (or current) and with the coil de-energized for 2 hours, in each of the three mutually perpendicular (x, y, and z) directions. Contacts shall be loaded as specified in 4.6.10d.
- c. Test condition: D, except vibration level is the lesser of .195 inch (4.95 mm) double amplitude or 30 G, and frequency range is 10 Hz to 3,000 Hz.
- d. Measurements during vibration: As specified in 4.6.10d.
- e. For group B testing, only one cycle shall be performed over the frequency range of 100 Hz to 3,000 Hz unless otherwise specified (see 3.1). The relay shall be vibrated in the direction of contact motion. At the option of the manufacturer, the relay production lot may be divided in three equal groups and each group shall be tested in one of three mutually perpendicular axes (X, Y, and Z). When relays are tested as specified in the optional procedure, a failure of any relay in any axis shall require 100 percent inspection of all relays in the production lot in each axis. For all contact forms except contact form "A", the cycle shall consist of 3 minutes up with the coil energized with rated voltage (or current) and 3 minutes down with coil de-energized. The cycle for form contact "A" shall consist of 3 minutes up with the coil de-energized and 3 minutes down with the coil energized.
- f. Examination after test: Prior to removal from test fixture and without disturbing the relay, apply maximum over the temperature range pickup voltage value (see 3.1) to the coil, and then verify that relay contacts transfer. Remove coil voltage (or current), and then verify that relay contacts transfer. Failure of relay contacts to transfer shall be cause for rejection. After removal from test fixture, the relays shall then be inspected for evidence of structural failure or other damage which might impair the operation of the relay.

4.6.11.2 Vibration (random). Relays shall be tested in accordance with MIL-STD-202-214. The following details and exceptions shall apply:

- a. Method of mounting: As specified in 4.6.10a.
- b. Electrical-load conditions: For qualification and group C inspections, relays shall be tested with the coil energized at rated voltage (or current) for 15 minutes and with the coil de-energized for 15 minutes, in each of three mutually perpendicular (x, y, and z) directions. When applicable to group A inspection, the test time shall be 3 minutes for each state described above. Contacts shall be monitored as specified in 4.6.11.2d.
- c. Test condition: IG (0.4 G²/Hz, 23.91 rms G).
- d. Tests during vibration: As specified in 4.6.10d.
- e. Examination after test: As specified in 4.6.11.1f.

MIL-DTL-5757M

4.6.12 Acceleration (unless otherwise specified, see 3.1 and 3.14). Relays shall be tested in accordance with MIL-STD-202-212. The following details and exceptions shall apply:

- a. Mounting of specimens: As specified in 4.6.10a.
- b. Test conditions: Test condition A, 17 G's, unless otherwise specified (see 3.1) (acceleration shall be applied in each direction along three mutually perpendicular axes (x, y, and z) of the specimen; one axis shall be in the direction most likely to cause malfunction). In each direction, the coil shall be de-energized for 5 minutes, rated coil voltage (or current) shall be momentarily applied; and the voltage or current shall be reduced to the maximum ambient pickup voltage as specified (see 3.1) for 5 minutes.
- c. Examination after test: As specified in 4.6.10e.

4.6.13 Terminal strength (see 3.15). Relays shall be tested in accordance with MIL-STD-202-211 in accordance with the following, as applicable. Unless otherwise specified herein, two terminals of each discrete design, size, and configuration shall be tested; however, if there is only one of such design, size, and configuration, it shall be tested.

4.6.13.1 Pull test (all terminal types). Terminals shall be tested as specified in test condition A, the force shall be as specified (see 3.1).

4.6.13.2 Bend test (not applicable to plug-in terminals). Terminals shall be tested as specified in test condition letter B (two bends) or C, as applicable. Loads for test condition letter C shall be as specified (see 3.1).

4.6.13.3. Bend test (plug-in terminals of a standard octal base only). The lesser of five or all terminals shall be tested by applying a force of five pounds perpendicular to the axis of the pin within .125 inch (3.17 mm) of the tip of the pin.

4.6.13.4 Twist test (wire lead terminals only). All terminals shall be tested as specified in test condition D, except during application of torsion, each terminal shall be rotated 45 degrees in one direction, then returned to start; rotated in opposite direction 45 degrees, then returned to start. Each terminal shall be subjected to two such rotations and returns. Each terminal shall be held at a point .75 inch (19.0 mm) from the point of emergence from the relay, or terminal end for relays with terminals less than .75 inch (19.0 mm), and in one plane shall be bent 20 degrees \pm 5 degrees in one direction, then returned to start; bent in opposite direction 20 degrees \pm 5 degrees, then returned to start. This procedure shall then be repeated in the perpendicular plane. Following these tests, relays shall be examined for evidence of loosening or breaking of the terminals and other damage that could adversely affect the normal operation of the relay.

4.6.14 Magnetic interference (when specified; see 3.1 and 3.16). Relays shall be tested in accordance with 4.6.14.1 or 4.6.14.2, as specified.

4.6.14.1 Uniform-stray-field. The relay shall be mounted by suitable nonmagnetic means within the central volume of the test coil. The critical axis of the relay shall be aligned with the longitudinal axis of the test coil. Pickup, hold, and dropout voltage (or current) shall be measured as specified in 4.6.8.2 in 0 magnetic field and in 100 gauss magnetic field of both polarities.

4.6.14.2 Adjacent-similar-relay. The relay under test and eight similar relays shall be mounted in the same physical orientation by nonmagnetic means, as shown on figure 8. Unless otherwise specified, grid-spaced relays shall be mounted so that all terminals are positioned in the closest possible grid pattern. The spacing between terminals and the tops of adjacent terminals shall be as shown on figure 8, unless otherwise specified. Pickup, hold, and dropout voltage (or current) shall be measured on the relay under test as specified in 4.6.8.2 with the coils of the eight outer relays energized at rated voltage (or current) (the magnetic polarity of each relay shall be similarly oriented). The measurement shall be repeated with the coils of the eight outer relays de-energized.

4.6.15 Contact sticking (reed relays only; see 3.1 and 3.17). Relays shall be energized for 96 hours with 120 percent of rated voltage (or current) applied to the coil. No load shall be applied to the contacts. At the end of this period, without physically disturbing the relay, the coil shall be de-energized and the release time shall be measured as specified in 4.6.8.4. This test may be performed as a part of the coil life test (see 4.6.16).

MIL-DTL-5757M

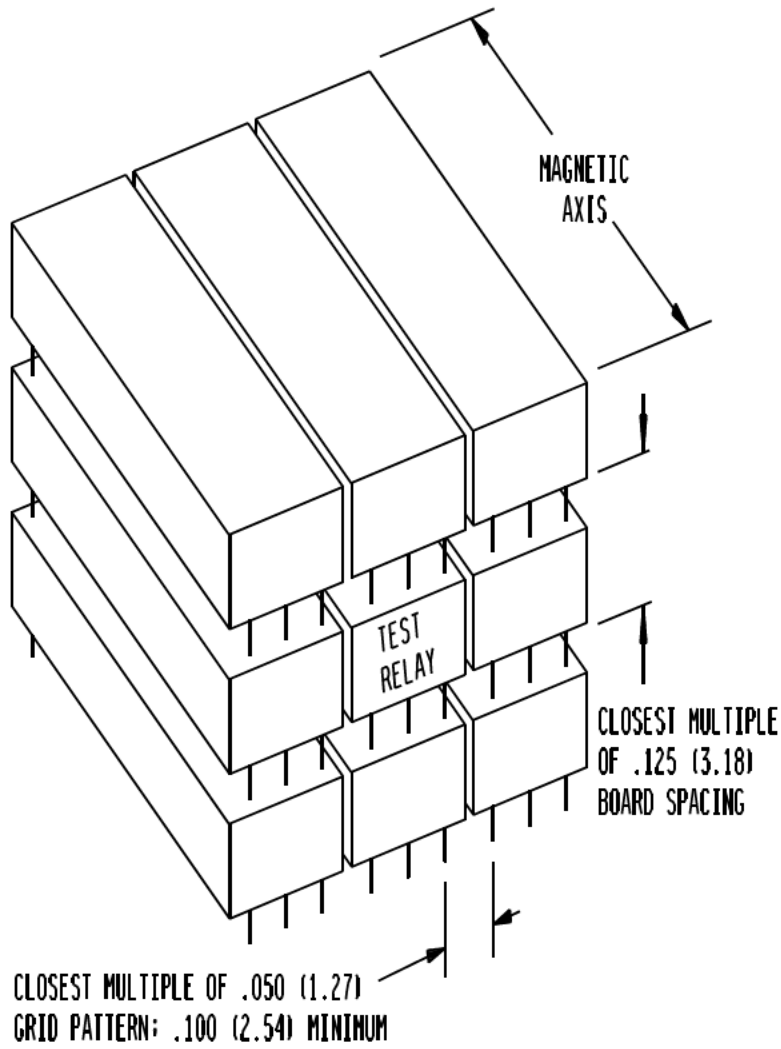

FIGURE 8. Mounting arrays for adjacent similar relays.

MIL-DTL-5757M

4.6.16 Coil life (unless otherwise specified, see 3.1) (see 3.18). Relays shall be tested for 1,000 hours as follows (see figure 9).

- a. Relays may be mounted as specified in 4.2.5. Each contact terminal shall be connected as specified in 4.6.8.1.1a.
- b. During the maximum temperature portion of the test, rated coil voltage (or current) (see 3.1) shall be applied continuously and at least half of the normally open contacts shall carry rated current. During room temperature and minimum temperature exposures, the coil shall be de-energized and contacts shall not be loaded. Ambient temperatures shall be varied as shown on figure 9, with heating and cooling rates not to exceed +1°C per second average. The portion of the cycle run at minimum temperature shall be approximately 10 percent of the test cycle time.
- c. After the first 100 hours, and while still at the low temperature extreme, static contact resistance (or voltage drop) (4.6.8.1.1) and operate and release time (4.6.8.4) shall be measured as specified and the value recorded. Measurements of coil resistance (or coil current as specified, see 3.1 and 4.6.8.3) and static contact resistance (4.6.8.1.1) shall be taken at room temperature initially, then again after 250 hours ±25 hours, 500 hours ±25 hours, and 750 hours ±25 hours and the values shall be recorded. Specified pickup, hold, and dropout values (voltages) measurements shall be made as specified in 4.6.8.2 during the last temperature cycle after allowing the relay to stabilize, de-energized, at each of the temperature extremes, and the values shall be recorded. Measurements of coil resistance (or coil current) as applicable (see 3.1), and static contact resistance as specified in 4.6.8.1.1 shall be taken at room temperature initially, then again after 125 hours ±12.5 hours, 250 hours ±12.5 hours, and 375 hours ±12.5 hours and the values shall be recorded.
- d. After the relay(s) have been subjected to the coil life temperature cycles, measurements shall then be taken at room temperature of dielectric withstanding voltage (4.6.7.1), insulation resistance (4.6.6), static contact resistance (4.6.8.1.1), coil resistance (or coil current) (4.6.8.3), operate and release time (4.6.8.4), and contact bounce (4.6.8.3.3).
- e. Examination after test: As specified in 4.6.10e.

4.6.17 Resistance to soldering heat (see 3.19). Relays shall be tested in accordance with MIL-STD-202-211. The following details and exceptions shall apply:

- a. Depth of immersion in molten solder: Within .060 inch ±.020 inch (1.52 mm ±0.51 mm) of the relay base.
- b. Test condition: B.
- c. Measurements after test: Insulation resistance (4.6.6), static contact resistance (4.6.8.1.1), specified pickup, hold, and dropout values (voltage or current)(4.6.8.2), and coil resistance (or coil current as specified; see 3.1 and 4.6.8.3) shall be measured as specified.
- d. Examination after test: As specified in 4.6.10e.

4.6.18 Salt spray or salt atmosphere (corrosion), MIL-STD-202 (see 3.20). Relays shall be tested in accordance with MIL-STD-202-101 unless otherwise specified (see 3.1). The following details and exceptions shall apply:

- a. Applicable salt solution: 5 percent.
- b. Test condition: B.
- c. Examination after test: Relays shall be examined for evidence of peeling, chipping, blistering of the finish, and exposure of base metal due to corrosion that can adversely affect the operation or performance of the relay.

MIL-DTL-5757M

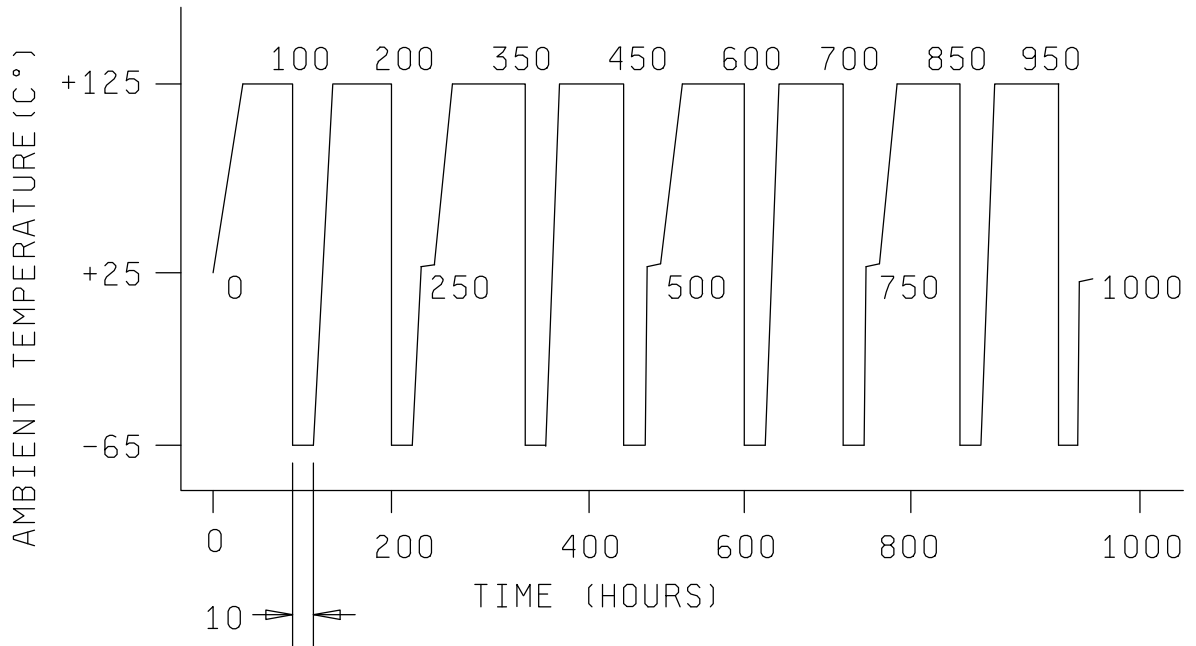
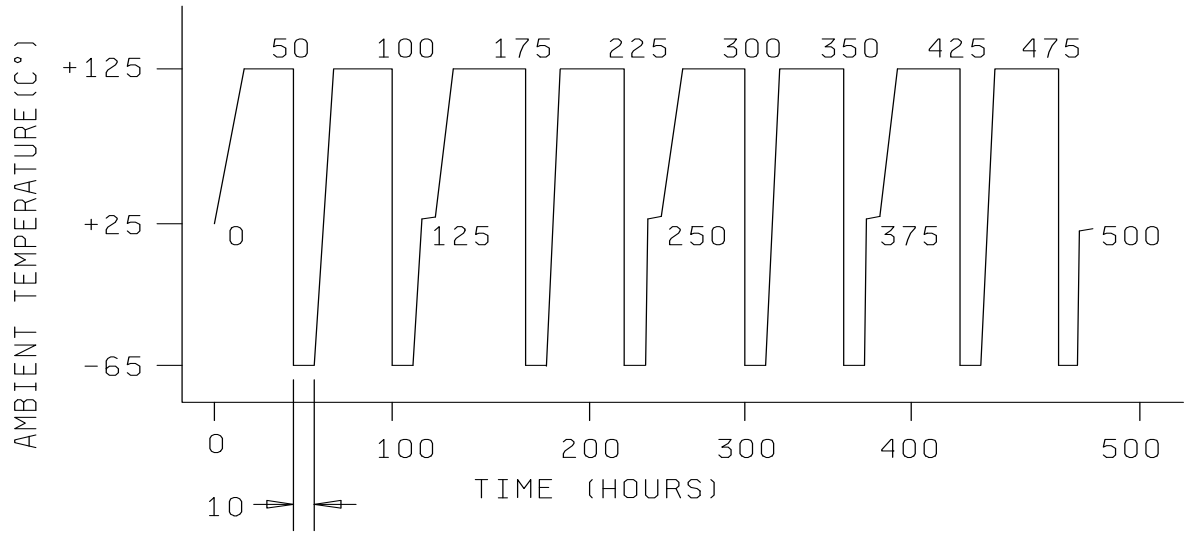

FIGURE 9. Coil life ambient temperatures.

MIL-DTL-5757M

4.6.19 Overload (applicable to high level relays only) (see 3.21). Relay contacts (both normally open and normally closed) shall be subjected to the tests specified in 4.6.19.1 and 4.6.19.2, as applicable. For double-throw relays, separate tests shall be performed for the normally open and the normally closed contacts. Relay coil energization shall be nonsynchronous with the power supply for ac loads. The number of cycles shall be 100 for dc contact loads, and 200 for ac contact loads ("on" and "off" times shall be approximately equal). The coil shall be energized at rated voltage (or current). Overload current shall be twice rated load current. The opening and closing of all contacts under test shall be continuously monitored to detect switching of the contacts. The equipment shall be capable of monitoring 40 percent minimum of the actual opened and closed time of each contact. The equipment shall automatically cut off when a failure occurs, or shall record any failures. The relay case shall be connected to system ground through a normal-blow fuse rated at 5 percent of the test current or 100 mA, whichever is greater. After the test, the fuse shall be tested for electrical continuity.

4.6.19.1 Resistive load. Suitable noninductive resistors shall be used. Cycling rate shall be 20 cycles per minute (cpm) ± 2 cpm.

4.6.19.2 Inductive load. Cycling rate shall be 10 cpm ± 1 cpm. Inductive load testing shall be approved by the qualifying activity (see 6.11).

4.6.19.2.1 Inductive load, dc. Unless otherwise specified (see 3.1), dc inductive loads shall be computed in accordance with the following procedure:

- a. The relay shall be mounted in its normal operating position on a nonmagnetic plate with no immediately adjacent metal.
- b. The load circuit shall be energized through a bounce free contact from a power supply regulated to within 5 percent of the specified rated voltage (or current) as shown on figure 10.
- c. By measuring the time for the current to reach 63 percent of its final value, the dc inductance is calculated as:

$$L = Rt$$

Where:

- L - is the inductance in henries,
- R - is the resistance of the load circuit, and
- t - is the time in seconds for current to reach 63 percent of its final value.

4.6.19.2.2 Inductive load, ac. The load shall consist of inductive and resistive elements with 0.7 lagging power ± 0.05 lagging power factor at the voltage and frequency specified (see 3.1).

4.6.20 Life (see 3.22). Unless otherwise specified (see 3.1), relays shall be operated for 100,000 cycles with contacts loaded in accordance with 4.2.3 and 4.6.20.1 through 4.6.20.4 inclusive, as applicable. Relay coil energization shall be nonsynchronous with the power supply for ac loads. Each relay case shall be connected to system ground through an individual normal-blow fuse rated at the greater of 100 mA or 5 percent of load current. The ambient temperature of the interior of the test chamber shall be +125°C minimum. The contact resistance or voltage drop, as applicable, shall be monitored during 40 percent minimum of each "on" and each "off" period. The monitoring equipment shall automatically hold the relay under test in the state in which the failure occurs (energized or de-energized) and the contact voltage shall be removed. All contacts in each sample unit shall switch identical loads. Following cycling, the electrical continuity of each case-grounding fuse shall be checked.

- a. Level I. Relays shall be subjected to 100,000 operations (unless otherwise specified; see 3.1) at the rate of 20 cycles ± 2 cycles per minute, with "on" and "off" times approximately equal.
- b. Level II. Relays shall be subjected to 50,000 operations (unless otherwise specified; see 3.1) at the rate of 29 seconds ± 3 seconds "on" and one and one-half seconds ± 0.5 second "off".

4.6.20.1 Resistive load. Cycling rate shall be 20 cycles ± 2 cycles per minute. Suitable resistors shall be used. Current shall be rated resistive current as specified (see 3.1).

MIL-DTL-5757M

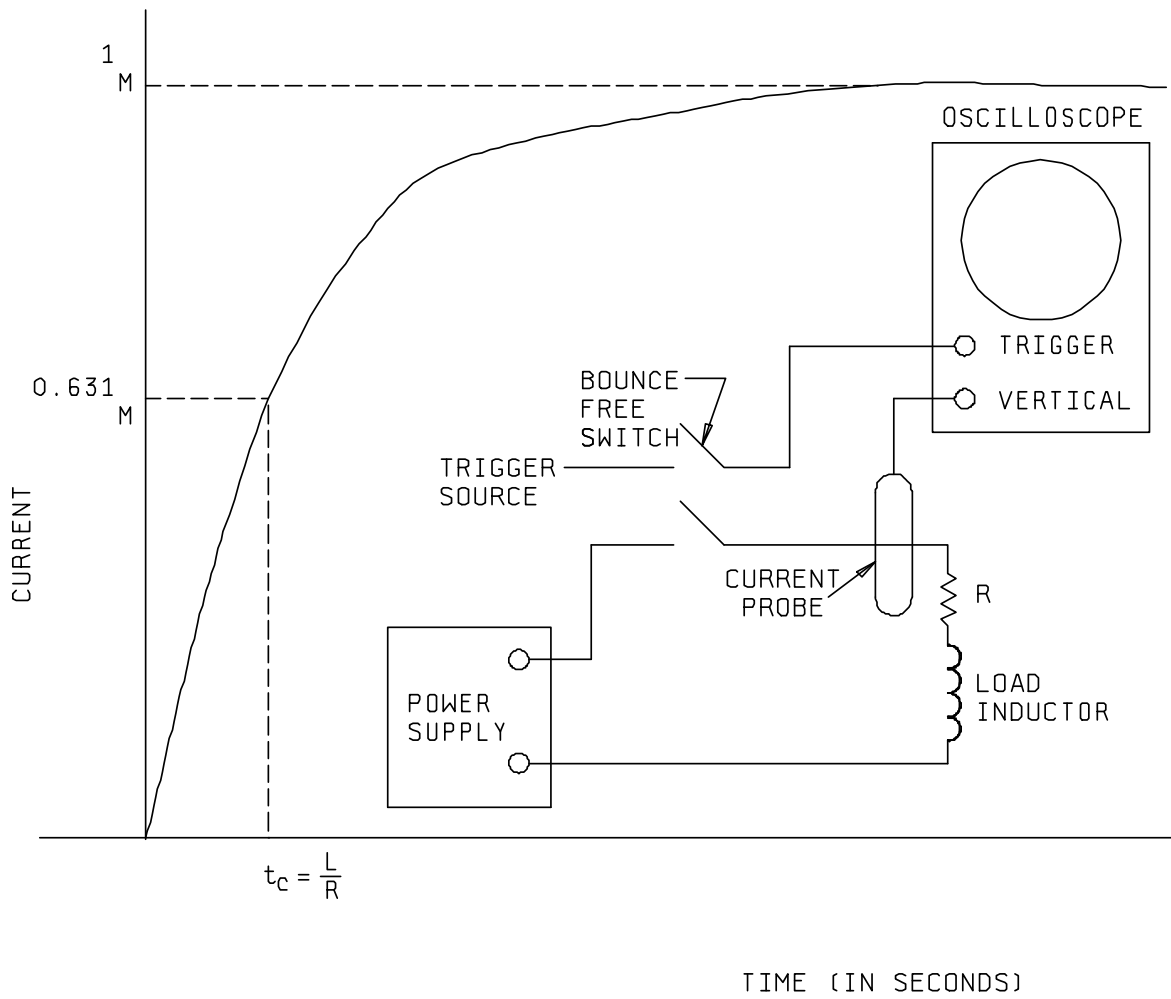

FIGURE 10. DC inductive load (inductive current rise time curve).

MIL-DTL-5757M

4.6.20.2 Inductive load. Cycling rate shall be 10 cycles \pm 1 cycle per minute with approximately equal "on" and "off" periods. Current shall be rated current. Appropriate inductive load components (see 4.6.19.2.1 and 4.6.19.2.2, as applicable) shall be used. A suitable resistor may be placed in the circuit to obtain rated steady-state current flow. Inductive load testing shall be approved by the qualifying activity (see 6.11).

4.6.20.3 Lamp load. Unless otherwise specified, the lamp load shall be performed with a 28 V dc power supply voltage. Either lamps or simulated loads may be used to provide the load as follows:

- a. Simulated loads shall subject the relays to making 12 times the rated lamp load and breaking the rated lamp load. The duration of the 12 times inrush shall be 0.015 second to 0.020 second. The total "on" time shall be 5 seconds \pm 0.05 second and the "off" time shall be 5 seconds \pm 0.05 second.
- b. Lamps shall be screened to verify a minimum initial cold inrush of 12 times the rated lamp load. Only lamps meeting this requirement shall be used to provide load to the relays. The total "on" time shall be 2 seconds \pm 0.05 second and the "off" time shall be 7 seconds \pm 2 seconds.

4.6.20.4 Low level. Relays shall be tested in accordance with MIL-STD-202-311. The following details apply:

- a. Number of misses which will be considered a failure: One.
- b. Maximum contact resistance allowed: See 3.1.
- c. Number of cycles of operation and cycling rate: 100,000 cycles, unless otherwise specified (see 3.1) at the rate of 60 cycles to 300 cycles per minute (c/m).
- d. Contact load: 10 μ A to 50 μ A at 10 mV to 50 mV open circuit (maximum dc or peak ac).
- e. Dry reed contact load: 10 mA maximum at 30 mV open circuit (maximum dc or peak ac).

4.6.21 Intermediate current (see 3.23). Intermediate current shall not be considered a low level or high level contact load rating (see 6.1.1). Relays shall be tested as specified in MIL-STD-202-312. The following details and exceptions shall apply:

- a. Maximum contact resistance: As specified in 3.24.
- b. Coil energizing voltage: Rated voltage (or current) (see 3.1).
- c. Cycling rate: Ten cycles \pm 2 cycles per minute with minimum of 75 percent coil "ON" time.
- d. Contact current/voltage: 100 mA at 28 V dc.
- e. Monitoring: At least 40 percent of the closed time of each contact during each operation shall be monitored for contact resistance.
- f. Number of cycles: 50,000 cycles.
- g. Ambient temperature: +125°C minimum.

MIL-DTL-5757M

4.6.22 Mixed loads (applicable to high level relays only; see 3.24). For qualification inspection, relays shall be tested in accordance with 4.6.20.1 or 4.6.20.2, as specified (see 3.1). Relays shall be mounted as specified in 4.2.5. The ambient temperature of the test chamber shall be the maximum temperature rating of the relay. Unless otherwise specified (see 3.1), coils shall be energized with rated voltage (or current) at the rate specified herein; however, intermittent duty and pulse-operated relays shall be operated as specified (see 3.1). The same type load shall be used for each contact of the same pole. Contacts shall be monitored for dynamic contact resistance at each operation; however, unless otherwise specified (see 3.1), contacts carrying rated resistive load need not be monitored. Unless otherwise specified (see 3.1), contacts shall be loaded as follows; however, if any load specified herein exceeds the contact rating (see 3.1), the load shall be as specified (see 3.1). For group B inspection, relays shall be tested as specified herein, except that the number of operations shall be 10,000. The following details and exceptions apply:

- a. Maximum static contact resistance: As specified in 3.10.1.
- b. Coil energizing voltage: Rated voltage (or current) (see 3.1).
- c. Cycling rate: Ten cycles ± 2 cycles per minute with minimum of 75 percent coil "ON" time.
- d. Contact current/voltage: 100 mA at 28 V dc.
- e. Monitoring: At least 40 percent of the closed time of each contact during each operation shall be monitored for contact resistance.
- f. Number of cycles: 50,000 cycles.
- g. Ambient temperature: +125°C minimum.

Two pole relays shall be tested as follows:

- Sample 1 (pole 1): 0.1 ampere resistive at 28 ± 1 V dc.
(pole 2): rated resistive load at 28 ± 1 V dc.
- Sample 2 (pole 1): 0.3 ampere inductive load (220 mH) at 28 ± 1 V dc.
(pole 2): rated resistive load at 28 ± 1 V dc.
- Sample 3 (pole 1): 0.5 ampere resistive at 28 ± 1 V dc.
(pole 2): rated resistive load at 28 ± 1 V dc.
- Sample 4 (pole 1): 0.1 ampere resistive at 28 ± 1 V dc.
(pole 2): rated resistive load at 28 ± 1 V dc.

Three pole relays shall be tested as follows:

- Sample 1 (pole 1): 0.1 ampere resistive at 28 ± 1 V dc.
(pole 2): 0.3 ampere inductive load (220 mH) at 28 ± 1 V dc.
(pole 3): rated resistive load at 28 ± 1 V dc.
- Sample 2 (pole 1): 0.1 ampere resistive at 28 ± 1 V dc.
(pole 2): 0.5 ampere resistive at 28 ± 1 V dc.
(pole 3): rated resistive load at 28 ± 1 V dc.
- Sample 3 (pole 1): 0.3 ampere inductive load (220 mH) at 28 ± 1 V dc.
(pole 2): 0.5 ampere resistive at 28 ± 1 V dc.
(pole 3): rated resistive load at 28 ± 1 V dc.
- Sample 4 (pole 1): 0.1 ampere resistive at 28 ± 1 V dc.
(pole 2): 0.3 ampere inductive load (220 mH) at 28 ± 1 V dc.
(pole 3): rated resistive load at 28 ± 1 V dc.

MIL-DTL-5757M

Four pole relays shall be tested as follows:

- Samples 1 through 4 (pole 1): 0.1 ampere resistive at 28 ± 1 V dc.
- (pole 2): 0.3 ampere inductive load (220 mH) at 28 ± 1 V dc.
- (pole 3): 0.5 ampere resistive at 28 ± 1 V dc.
- (pole 4): rated resistive load at 28 ± 1 V dc.

Six pole relays shall be tested as follows:

- Samples 1 through 4 (pole 1): 0.1 ampere resistive at 28 ± 1 V dc.
- (pole 2): 0.3 ampere inductive load (220 mH) at 28 ± 1 V dc.
- (pole 3): 0.5 ampere resistive at 28 ± 1 V dc.
- (pole 4): rated resistive load at 28 ± 1 V dc.
- (pole 5): 0.1 ampere resistive at 28 ± 1 V dc.
- (pole 6): rated resistive load at 28 ± 1 V dc.

4.6.23 Mechanical life (see 3.25). Relays shall be cycled one million cycles at room ambient temperature. The cycling rate shall be as specified in 4.6.20.4. Each contact load shall be 10 μ A to 50 μ A at 10 mV to 50 mV (dc or peak ac). The coil shall be energized at rated voltage (or current) during 50 percent \pm 10 percent of each cycle.

4.6.24 Resistance to solvents (see 3.26). Relays shall be tested in accordance with MIL-STD-202-215. The following details and exceptions shall apply:

- a. Portion to be brushed: All marking.
- b. Specimens to be tested: One sample shall be tested with each solvent solution. For qualification inspection, samples in excess of the available number of solvents shall be exempt from test. For group C testing, two additional samples shall be selected. The additional samples may be electrical rejects from group A2.
- c. Examination: Specimens shall be examined for legibility of marking.

5. PACKAGING

5.1 Packaging. For acquisition purposes, the packaging requirements shall be as specified in the contract or order (see 6.2). When packaging of materiel is to be performed by DoD or in-house contractor personnel, these personnel need to contact the responsible packaging activity to ascertain packaging requirements. Packaging requirements are maintained by the Inventory Control Point's packaging activities within the Military Service or Defense Agency, or within the military service's system commands. Packaging data retrieval is available from the managing Military Department's or Defense Agency's automated packaging files, CD-ROM products, or by contacting the responsible packaging activity.

6. NOTES

(This section contains information of a general or explanatory nature that may be helpful, but is not mandatory.)

6.1 Intended use. Relays conforming to this specification are intended for use in electronic and communication equipment. Their principal areas of application are for aircraft, missiles, spacecraft and ground-support electronic and communication equipment. This does not preclude the use of these relays in other military applications. The relays covered by this specification will be able to operate satisfactorily in systems under the following demanding conditions: vibration up to 15 g's shock of 100 g's, and temperature ranges of -65°C to $+125^{\circ}\text{C}$

CAUTION: The use of any coil voltage (or current) less than the rated coil voltage (or current) will compromise the operation of the relay.

MIL-DTL-5757M

6.1.1 Contact rating. The contact ratings of relays covered by this specification are based on load endurance tests which establish the relay capability to switch rated loads. For the purposes of this specification, contact load ratings are defined as follows:

- a. Low level: 10 μ A at 50 mV to 10 mA at 6 V.
- b. Intermediate: 10 mA at 6 V to 100 mA at 28 V.
- c. High level: Above 100 mA at 28 V.

6.2 Acquisition requirements. Acquisition documents must specify the following:

- a. Title, number, and date of the specification, date of the applicable specification sheet, and the PIN.
- b. Packaging requirements (see 5.1).
- c. Special or additional identification marking requirements.

6.2.1 Manufacturer provided services. The manufacturer may provide the following optional value added services when specified in the order:

- a. Hot solder dipping of terminals (see 3.4.7.5).
- b. Shortening of wire leads (see 3.4.7.2).

6.3 Qualification. With respect to products requiring qualification, awards will be made only for products which are, at the time of award of contract, qualified for inclusion in Qualified Products List QPL No. 5757 whether or not such products have actually been so listed by that date. The attention of the contractors is called to these requirements, and manufacturers are urged to arrange to have the products that they propose to offer to the Federal Government tested for qualification in order that they may be eligible to be awarded contracts or orders for the products covered by this specification. Information pertaining to qualification of products may be obtained from (Relays Team, P.O. Box 3990, Columbus, OH 43218-3990, or vqp.kr@dla.mil). An online listing of products qualified to this specification may be found in the Qualified Products Database (QPD) at <https://assist.dla.mil>.

6.3.1 Provisions Governing Qualification SD-6. Copies of "Provisions Governing Qualification SD-6" may be obtained upon application to the Standardization Documents Order Desk, Building 4D, 700 Robbins Avenue, Philadelphia, PA 19111-5094.

6.4 Shelf life. Relays conforming to this specification should be designed for a minimum of 7 years shelf life, following which the relays should be satisfactory for intended use without further conditioning.

6.5 Sealing. The following procedure is suggested as a guide; however, every effort should be made to utilize the most effective procedure consistent with the state of the art.

- a. Evacuate to less than 200 microns.
- b. Heat to maximum rated ambient temperature with continued evacuation (see 3.1).
- c. Maintain heat and vacuum for 12 hours or longer, continuing the treatment until a maximum pressure of 80 microns is reached.
- d. Turn off heaters and maintain pressure for 4 hours.
- e. Close evacuation valve and fill chamber with the desired pressurizing gas.
- f. Seal relay before removing from chamber.

MIL-DTL-5757M

6.6 Intermetallic contact. The finishing of metallic areas to be placed in intimate contact by assembly presents a special problem, since intermetallic contact of dissimilar metals results in electrolytic couples which promote corrosion through galvanic action. To provide the required corrosion protection, intermetallic couples are restricted to those permitted by [MIL-HBK-889](#).

6.7 Tin whisker growth. The use of alloys with tin content greater than 97 percent, by mass, may exhibit tin whisker growth problems after manufacture. Tin whiskers may occur anytime from a day to years after manufacture and can develop under typical operating conditions, on products that use such materials. Conformal coatings applied over top of a whisker-prone surface will not prevent the formation of tin whiskers. Alloys of 3 percent lead, by mass, have shown to inhibit the growth of tin whiskers. For additional information on this matter, refer to [ASTM-B545](#) (Standard Specification for Electrodeposited Coatings of Tin).

6.8 Fixturing losses. It is known that there is inherent resistance in sockets, wiring, etc.. The qualifying activity will evaluate the manufacturer's system to determine conformance to specification requirements.

6.9 Glossary. The definitions listed below are not a complete glossary of relay terminology, but rather are intended as definitions of the technical terms as applied within the specification.

Adjunct sealant: Any hydrocarbon or silicon material used on the exterior of the unit to improve the hermeticity of a hermetically sealed relay.

Bifilar winding: Two or more windings with the wire of each winding alongside the other, matching turn for turn; may be either inductive or noninductive.

Bounce time: The time interval between first make of the contact until the uncontrolled making and breaking of the contact ceases.

Chatter, contact: Externally caused, undesired vibration of mating contacts during which there may or may not be actual physical contact opening. If there is no actual opening but only a change in resistance, it is referred to as dynamic resistance.

Coil: One or more windings on a common form.

Contacts: The current-carrying parts of a relay that open or close electrical circuits.

Contact, bifurcated: A forked or branched, contacting member so formed or arranged, as to provide dual contacting.

Contact, closed: A normally-closed contact with the relay released is a closed contact. A normally-open contact with the relay operated is a closed contact.

Contact, open: A normally-closed contact with the relay operated is an open contact. A normally-open contact with the relay released is an open contact.

Contact arrangement: The combination of contact forms that make up the entire relay switching structure.

Contact bounce: Intermittent opening of contacts after initial closure due to contact impact.

Contact force: The force exerted by a movable contact against a mating contact when the contacts are closed.

Contact gap: The distance between a pair of mating relay contacts when the contacts are open.

Contact weld: A contact failure due to fusing of closed contacts, resulting in their failure to open.

Cycle, relay: A relay cycle is defined as a relay pickup and dropout, (one opening and one closure of a set of contacts). Therefore, a cycle consists of two operations.

Degassing: A process of thermally cleaning a relay (at elevated temperatures) to drive off harmful gasses. Degassing is usually performed using vacuum pumps.

MIL-DTL-5757M

Dropout value (voltage), specified: As the current or voltage on an operated relay is decreased, the value at or above which all relay contacts must restore to their unoperated positions.

Hermetically sealed relay: A relay contained within an enclosure that is sealed by fusion to insure a low rate of gas leakage. This usually refers to metal-to-metal, or metal-to-glass sealing.

Hold value (voltage), specified: As the current or voltage on an operated relay is decreased, the value which must be reached before any contact change occurs.

Miss: Failure to establish the intended circuit conditions (high or low output resistance, as applicable).

Normally closed contacts: Those contacts that are closed with the relay de-energized.

Normally open contacts: Those contacts that are open with the relay de-energized.

Operate time: The interval between the application of a step function input signal and closing of all normally open contacts. Bounce time is not included.

Operation, relay: A relay operation is defined as when a relay changes from an initial condition to the prescribed condition. For example, normally open to closed or vice versa. Therefore, a relay operation is one half of a cycle.

Pickup value (voltage), specified: As the current or voltage on an unoperated relay is increased, the value (voltage) at or below which all contacts must function.

Polarized relay: A relay, the operation of which is primarily dependent upon the direction (polarity) of the energizing current(s) and the resultant magnetic flux. The opposite of neutral relay. Also called "Polar Relay".

Relay: An electric device that is designed to interpret input conditions in a prescribed manner and after specified conditions are met to respond to cause contact operation or similar abrupt change in an associated electric control circuit. **NOTE:** 1) Inputs are usually electric, but may be mechanical, thermal or other quantities. 2) A relay may consist of several units, when responsive to specified inputs, the combination providing the desired performance characteristics..

Relay, differential: A double input relay which is actuated by the polar signal resulting from the algebraic addition of dual inputs.

Relay, null-seeking: A relay of double-throw configuration and a stable centeroff position. Either side of the double-throw contact can be activated by and for the duration of the polar actuating signal.

Relay, sensitive: A relay that operates on low input power commonly defined as 100 milliwatts or less.

Release time: The interval between the trailing edge of a step function input signal and closing of all normally closed contacts. Bounce time is not included.

Saturation: The condition attained in a magnetic material when an increase in magnetizing (coil) current produces no appreciable increase in flux.

Shelf life: A period of time a relay can be stored unused before detrimental changes occur which would cause the item not to properly perform its function within the requirements of this specification.

Silicone: Any of a group of semi-inorganic polymers based on the structural unit R_2SiO , where R is an organic group, characterized by wide range thermal stability, high lubricity, extreme water repellence, and physicochemical inertness, used in adhesives, lubricants, protective coatings, paints, electrical insulation, synthetic rubber, and prosthetic replacements for bodily parts.

Sensitivity: Pickup value expressed in terms of milliwatts (or watts).

Time, contact bounce: The time interval from initial closure of a contact to the end of bounce during pickup and dropout.

MIL-DTL-5757M

Time, operate: The time interval from coil energization to initial closure of the last open contact. Unless otherwise stated, it does not include contact bounce time.

Time, release: The time interval from coil de-energization to initial closure of the last open contact. Unless otherwise stated, it does not include bounce time.

Time, transfer: The time interval between the opening of the closed contact and the closing of the open contact of a break-make-contact combination. For multipole relays, transfer time is defined as the interval between the opening of the last closed contact and the closing of the first open contact of any set.

Voltage, rated coil: The coil voltage (or current) at which the relay is to operate and meet all specified electrical, mechanical and environmental requirements.

6.10 Subject term (key word) listing.

AC coil
 All welded
 Full size crystal can
 Half size crystal can
 Hermetically sealed
 Low level contact rating

6.11 Inductive load testing. Recommendations for performing inductive load testing is discussed in [MIL-HDBK-338](#).

6.12 Environmentally preferable material. Environmentally preferable materials should be used to the maximum extent possible to meet the requirements of this specification. As of the dating of this document, some of the chemicals the U.S. Environmental Protection Agency (EPA) are concentrating on are cadmium, lead, and mercury. Use of these materials should be minimized or eliminated unless needed to meet the requirements specified herein (see [Section 3](#)).

6.13 Changes from previous issue. The margins of this specification are marked with vertical lines to indicate where changes from the previous issue were made. This was done as a convenience only and the Government assumes no liability whatsoever for any inaccuracies in these notations. Bidders and contractors are cautioned to evaluate the requirements of this document based on the entire content irrespective of the marginal notations and relationship to the previous issue.

Custodians:

Army - CR
 Navy - EC
 Air Force - 85
 DLA-CC

Preparing activity:
 DLA - CC

(Project 5945-2016-037)

Review activities:

Army - AT, AV, CR4, MI
 Navy - AS, MC, OS
 Air Force - 99

NOTE: The activities listed above were interested in this document as of the date of this document. Since organizations and responsibilities can change, you should verify the currency of the information above using the ASSIST Online database at <https://assist.dla.mil/>.