

INCH-POUND

MIL-DTL-52618/4E  
26 January 2012  
SUPERSEDING  
MIL-DTL-52618/4D  
25 November 2002

DETAIL SPECIFICATION SHEET

FITTINGS, PIPE, ALUMINUM-ALLOY THREADED, 150-POUND,  
TEES (REDUCING SIZES)

This specification is approved for use by all Departments  
and Agencies of the Department of Defense.

The requirements for acquiring the product described herein shall consist of this specification sheet and MIL-DTL-52618.

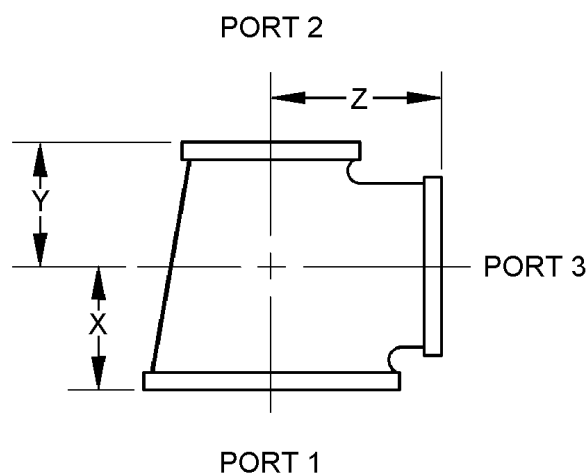

FIGURE 1. Tee reducing.

REQUIREMENTS:

The fittings shall be as specified on figure 1.

The design, dimensions, and tolerances of the reducing tees shall be in accordance with ASME B16.3.

Aluminum shall be in accordance with MIL-DTL-52618.

## MIL-DTL-52618/4E

The size of the largest run opening shall be given first, followed by the size of the opening at the opposite end of the run. The size of the side outlet or branch is given last; see figure 2, and examples:

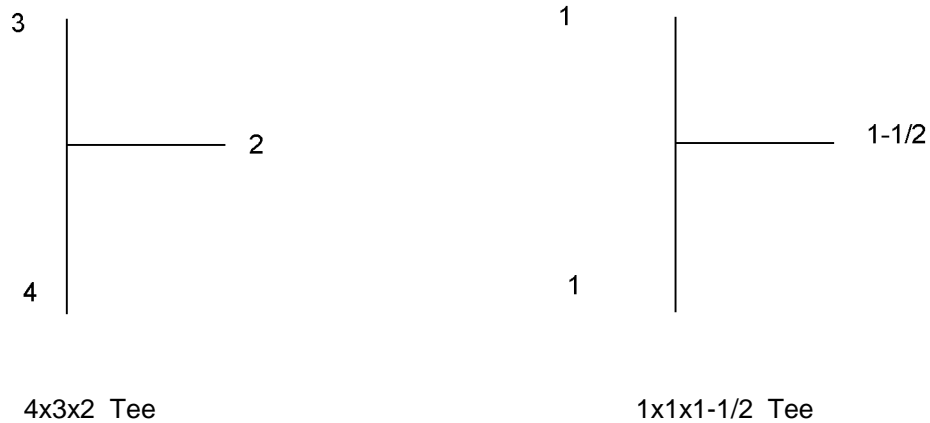
FIGURE 2. Run and branch.

Size code number designators shall be in accordance with table I.

TABLE I. Size code number for reducing tees.

| Size code number | Nominal pipe size<br>(inch) x (inch) x (branch inch) |   |        |   |        |
|------------------|--|---|--------|---|--------|
|                  | Port 1   |   | Port 2 |   | Port 3 |
| 405              | 1/2  | x | 1/2    | x | 3/8    |
| 406              | 1/2  | x | 1/2    | x | 1/4    |
| 410              | 3/4  | x | 3/4    | x | 1/2    |
| 411              | 3/4  | x | 3/4    | x | 3/8    |
| 412              | 3/4  | x | 3/4    | x | 1/4    |
| 413              | 3/4  | x | 1/2    | x | 3/4    |
| 414              | 3/4  | x | 1/2    | x | 1/2    |
| 415              | 1/2  | x | 1/2    | x | 3/4    |
| 416              | 1  | x | 1      | x | 3/4    |
| 417              | 1  | x | 1      | x | 1/2    |
| 418              | 1  | x | 1      | x | 3/8    |
| 419              | 1  | x | 3/4    | x | 1      |
| 420              | 1  | x | 3/4    | x | 3/4    |
| 421              | 1  | x | 3/4    | x | 1/2    |
| 422              | 1  | x | 1/2    | x | 1      |
| 423              | 1  | x | 1/2    | x | 3/4    |
| 424              | 1  | x | 1/2    | x | 1/2    |
| 425              | 1  | x | 3/8    | x | 1      |

## MIL-DTL-52618/4E

TABLE I. Size code number for reducing tees - Continued.

| Size code number | Nominal pipe size<br>(inch) x (inch) x (branch inch) |   |        |   |        |
|------------------|--|---|--------|---|--------|
|                  | Port 1   |   | Port 2 |   | Port 3 |
| 427              | 3/4  | x | 3/4    | x | 1      |
| 428              | 1-1/4  | x | 1-1/4  | x | 1      |
| 429              | 1-1/4  | x | 1-1/4  | x | 3/4    |
| 430              | 1-1/4  | x | 1-1/4  | x | 1/2    |
| 431              | 1-1/4  | x | 1      | x | 1-1/4  |
| 432              | 1-1/4  | x | 1      | x | 1      |
| 433              | 1-1/4  | x | 1      | x | 3/4    |
| 434              | 1-1/4  | x | 1      | x | 1/2    |
| 435              | 1-1/4  | x | 3/4    | x | 1-1/4  |
| 436              | 1-1/4  | x | 3/4    | x | 1      |
| 437              | 1-1/4  | x | 3/4    | x | 3/4    |
| 438              | 1-1/4  | x | 1/2    | x | 1-1/4  |
| 439              | 1-1/4  | x | 1/2    | x | 1      |
| 440              | 1  | x | 1      | x | 1-1/4  |
| 441              | 1-1/2  | x | 1-1/2  | x | 1-1/4  |
| 442              | 1-1/2  | x | 1-1/2  | x | 1      |
| 443              | 1-1/2  | x | 1-1/2  | x | 3/4    |
| 444              | 1-1/2  | x | 1-1/2  | x | 1/2    |
| 445              | 1-1/2  | x | 1-1/4  | x | 1-1/2  |
| 446              | 1-1/2  | x | 1-1/4  | x | 1-1/4  |
| 447              | 1-1/2  | x | 1-1/4  | x | 1      |
| 448              | 1-1/2  | x | 1-1/4  | x | 3/4    |
| 449              | 1-1/2  | x | 1-1/4  | x | 1/2    |
| 450              | 1-1/2  | x | 1      | x | 1-1/2  |
| 451              | 1-1/2  | x | 1      | x | 1-1/4  |
| 452              | 1-1/2  | x | 1      | x | 1      |
| 453              | 1-1/2  | x | 3/4    | x | 1-1/2  |
| 454              | 1-1/2  | x | 3/4    | x | 1-1/4  |
| 455              | 1-1/2  | x | 1/2    | x | 1-1/2  |
| 456              | 1-1/4  | x | 1-1/4  | x | 1-1/2  |
| 457              | 1-1/4  | x | 1      | x | 1-1/2  |
| 458              | 1  | x | 1      | x | 1-1/2  |
| 459              | 2  | x | 2      | x | 1-1/2  |
| 460              | 2  | x | 2      | x | 1-1/4  |
| 461              | 2  | x | 2      | x | 1      |
| 462              | 2  | x | 2      | x | 3/4    |
| 463              | 2  | x | 2      | x | 1/2    |
| 464              | 2  | x | 1-1/2  | x | 2      |
| 465              | 2  | x | 1-1/2  | x | 1-1/2  |
| 466              | 2  | x | 1-1/2  | x | 1-1/4  |
| 467              | 2  | x | 1-1/2  | x | 1      |
| 468              | 2  | x | 1-1/2  | x | 3/4    |
| 469              | 2  | x | 1-1/2  | x | 1/2    |
| 470              | 2  | x | 1-1/4  | x | 2      |

## MIL-DTL-52618/4E

TABLE I. Size code number for reducing tees - Continued.

| Size code number | Nominal pipe size<br>(inch) x (inch) x (branch inch) |   |        |   |        |
|------------------|--|---|--------|---|--------|
|                  | Port 1   |   | Port 2 |   | Port 3 |
| 471              | 2  | x | 1-1/4  | x | 1-1/2  |
| 472              | 2  | x | 1-1/4  | x | 1-1/4  |
| 473              | 2  | x | 1-1/4  | x | 1      |
| 474              | 2  | x | 1      | x | 2      |
| 475              | 2  | x | 1      | x | 1-1/2  |
| 476              | 2  | x | 1      | x | 1-1/4  |
| 477              | 2  | x | 3/4    | x | 2      |
| 478              | 2  | x | 1/2    | x | 2      |
| 479              | 1-1/2  | x | 1      | x | 2      |
| 480              | 1-1/4  | x | 1-1/4  | x | 2      |
| 481              | 1-1/2  | x | 1-1/2  | x | 2      |
| 482              | 1-1/2  | x | 1-1/4  | x | 2      |
| 483              | 2-1/2  | x | 2-1/2  | x | 2      |
| 484              | 2-1/2  | x | 2-1/2  | x | 1-1/2  |
| 485              | 2-1/2  | x | 2-1/2  | x | 1-1/4  |
| 486              | 2-1/2  | x | 2-1/2  | x | 1      |
| 487              | 2-1/2  | x | 2-1/2  | x | 3/4    |
| 488              | 2-1/2  | x | 2-1/2  | x | 1/2    |
| 489              | 2-1/2  | x | 2      | x | 2-1/2  |
| 490              | 2-1/2  | x | 2      | x | 2      |
| 491              | 2-1/2  | x | 2      | x | 1-1/2  |
| 492              | 2-1/2  | x | 2      | x | 1-1/4  |
| 493              | 2-1/2  | x | 2      | x | 1      |
| 494              | 2-1/2  | x | 2      | x | 3/4    |
| 495              | 2-1/2  | x | 2      | x | 1/2    |
| 496              | 2-1/2  | x | 1-1/2  | x | 2-1/2  |
| 497              | 2-1/2  | x | 1-1/2  | x | 2      |
| 498              | 2-1/2  | x | 1-1/2  | x | 1-1/2  |
| 499              | 2-1/2  | x | 1-1/4  | x | 2-1/2  |
| 500              | 2-1/2  | x | 1-1/4  | x | 2      |
| 501              | 2-1/2  | x | 1      | x | 2-1/2  |
| 502              | 2-1/2  | x | 1      | x | 2      |
| 503              | 2-1/2  | x | 3/4    | x | 2-1/2  |
| 504              | 2-1/2  | x | 1/2    | x | 2-1/2  |
| 505              | 2  | x | 2      | x | 2-1/2  |
| 506              | 2  | x | 1-1/2  | x | 2-1/2  |
| 507              | 2  | x | 1-1/4  | x | 2-1/2  |
| 508              | 1-1/2  | x | 1-1/2  | x | 2-1/2  |
| 509              | 3  | x | 3      | x | 2-1/2  |
| 510              | 3  | x | 3      | x | 2      |
| 511              | 3  | x | 3      | x | 1-1/2  |
| 512              | 3  | x | 3      | x | 1-1/4  |
| 514              | 3  | x | 3      | x | 3/4    |
| 515              | 3  | x | 3      | x | 1/2    |
| 516              | 3  | x | 2-1/2  | x | 3      |

## MIL-DTL-52618/4E

TABLE I. Size code number for reducing tees - Continued.

| Size code number | Nominal pipe size<br>(inch) x (inch) x (branch inch) |   |        |   |        |
|------------------|--|---|--------|---|--------|
|                  | Port 1   |   | Port 2 |   | Port 3 |
| 517              | 3  | x | 2-1/2  | x | 2-1/2  |
| 518              | 3  | x | 2-1/2  | x | 2      |
| 519              | 3  | x | 2-1/2  | x | 1-1/2  |
| 520              | 3  | x | 2-1/2  | x | 1-1/4  |
| 521              | 3  | x | 2-1/2  | x | 1      |
| 522              | 3  | x | 2-1/2  | x | 3      |
| 523              | 3  | x | 2      | x | 2-1/2  |
| 524              | 3  | x | 2      | x | 2      |
| 525              | 3  | x | 2      | x | 1-1/2  |
| 526              | 3  | x | 1-1/2  | x | 3      |
| 527              | 3  | x | 1-1/4  | x | 3      |
| 528              | 3  | x | 1      | x | 3      |
| 529              | 3  | x | 3/4    | x | 3      |
| 530              | 2-1/2  | x | 2-1/2  | x | 3      |
| 531              | 2-1/2  | x | 2      | x | 3      |
| 532              | 2  | x | 2      | x | 3      |
| 533              | 3-1/2  | x | 3-1/2  | x | 3      |
| 534              | 3-1/2  | x | 3-1/2  | x | 2-1/2  |
| 535              | 3-1/2  | x | 3-1/2  | x | 2      |
| 536              | 3-1/2  | x | 3-1/2  | x | 1-1/2  |
| 537              | 3-1/2  | x | 3-1/2  | x | 1-1/4  |
| 538              | 3-1/2  | x | 3-1/2  | x | 1      |
| 539              | 3-1/2  | x | 3      | x | 3      |
| 540              | 3-1/2  | x | 3      | x | 2-1/2  |
| 541              | 3-1/2  | x | 3      | x | 2      |
| 542              | 3-1/2  | x | 3      | x | 1-1/2  |
| 543              | 3-1/2  | x | 2-1/2  | x | 3-1/2  |
| 544              | 3-1/2  | x | 2-1/2  | x | 3      |
| 545              | 3-1/2  | x | 2-1/2  | x | 2-1/2  |
| 546              | 3-1/2  | x | 2      | x | 3-1/2  |
| 547              | 3-1/2  | x | 1-1/2  | x | 3-1/2  |
| 548              | 3-1/2  | x | 1-1/4  | x | 3-1/2  |
| 549              | 3-1/2  | x | 1      | x | 3-1/2  |
| 550              | 3  | x | 3      | x | 3-1/2  |
| 551              | 4  | x | 4      | x | 3-1/2  |
| 552              | 4  | x | 4      | x | 3      |
| 553              | 4  | x | 4      | x | 2-1/2  |
| 554              | 4  | x | 4      | x | 2      |
| 555              | 4  | x | 4      | x | 1-1/2  |
| 556              | 4  | x | 4      | x | 1-1/4  |
| 557              | 4  | x | 4      | x | 1      |
| 558              | 4  | x | 4      | x | 3/4    |
| 559              | 4  | x | 3-1/2  | x | 4      |
| 560              | 4  | x | 3-1/2  | x | 3-1/2  |
| 561              | 4  | x | 3-1/2  | x | 3      |

## MIL-DTL-52618/4E

TABLE I. Size code number for reducing tees - Continued.

| Size code number | Nominal pipe size<br>(inch) x (inch) x (branch inch) |   |        |   |        |
|------------------|--|---|--------|---|--------|
|                  | Port 1   |   | Port 2 |   | Port 3 |
| 562              | 4  | x | 3-1/2  | x | 2-1/2  |
| 563              | 4  | x | 3-1/2  | x | 2      |
| 564              | 4  | x | 3-1/2  | x | 1-1/2  |
| 565              | 4  | x | 3-1/2  | x | 1-1/4  |
| 566              | 4  | x | 3      | x | 4      |
| 568              | 4  | x | 3      | x | 2-1/2  |
| 569              | 4  | x | 3      | x | 2      |
| 570              | 4  | x | 2-1/2  | x | 4      |
| 571              | 4  | x | 2-1/2  | x | 3      |
| 572              | 4  | x | 2-1/2  | x | 2-1/2  |
| 573              | 4  | x | 2      | x | 4      |
| 574              | 4  | x | 2      | x | 3      |
| 575              | 4  | x | 2      | x | 2      |
| 576              | 4  | x | 1-1/2  | x | 4      |
| 577              | 4  | x | 1-1/4  | x | 4      |
| 578              | 4  | x | 1      | x | 4      |
| 579              | 3-1/2  | x | 3-1/2  | x | 4      |
| 580              | 3  | x | 3      | x | 4      |
| 581              | 2-1/2  | x | 2-1/2  | x | 4      |
| 582              | 2  | x | 2      | x | 4      |
| 583              | 5  | x | 5      | x | 4      |
| 584              | 5  | x | 5      | x | 3-1/2  |
| 585              | 5  | x | 5      | x | 3      |
| 586              | 5  | x | 5      | x | 2-1/2  |
| 587              | 5  | x | 5      | x | 2      |
| 588              | 5  | x | 5      | x | 1-1/2  |
| 589              | 5  | x | 5      | x | 1-1/4  |
| 590              | 5  | x | 5      | x | 1      |
| 591              | 5  | x | 4      | x | 5      |
| 592              | 5  | x | 1      | x | 4      |
| 593              | 5  | x | 4      | x | 3-1/2  |
| 594              | 5  | x | 4      | x | 3      |
| 595              | 5  | x | 4      | x | 2-1/2  |
| 596              | 5  | x | 4      | x | 2      |
| 597              | 5  | x | 4      | x | 1-1/2  |
| 598              | 5  | x | 3      | x | 5      |
| 599              | 5  | x | 3      | x | 4      |
| 600              | 5  | x | 3      | x | 3      |
| 601              | 5  | x | 2-1/2  | x | 5      |
| 602              | 5  | x | 2      | x | 5      |
| 603              | 4  | x | 4      | x | 5      |
| 604              | 6  | x | 6      | x | 5      |
| 605              | 6  | x | 6      | x | 4      |
| 606              | 6  | x | 6      | x | 3      |
| 607              | 6  | x | 6      | x | 2-1/2  |

## MIL-DTL-52618/4E

TABLE I. Size code number for reducing tees - Continued.

| Size code number | Nominal pipe size<br>(inch) x (inch) x (branch inch) |   |        |   |        |
|------------------|--|---|--------|---|--------|
|                  | Port 1   |   | Port 2 |   | Port 3 |
| 608              | 6  | x | 6      | x | 2      |
| 609              | 6  | x | 6      | x | 1-1/2  |
| 610              | 6  | x | 6      | x | 1-1/4  |
| 611              | 6  | x | 6      | x | 1      |
| 612              | 6  | x | 5      | x | 6      |
| 613              | 6  | x | 5      | x | 5      |
| 615              | 6  | x | 5      | x | 3      |
| 616              | 6  | x | 5      | x | 2-1/2  |
| 617              | 6  | x | 5      | x | 2      |
| 618              | 6  | x | 4      | x | 6      |
| 619              | 6  | x | 4      | x | 5      |
| 620              | 6  | x | 4      | x | 4      |
| 621              | 6  | x | 3      | x | 6      |
| 622              | 6  | x | 3      | x | 3      |
| 623              | 6  | x | 2-1/2  | x | 6      |
| 624              | 6  | x | 2      | x | 6      |
| 625              | 5  | x | 5      | x | 6      |
| 626              | 5  | x | 3      | x | 6      |
| 627              | 4  | x | 4      | x | 6      |
| 628              | 8  | x | 8      | x | 6      |
| 629              | 8  | x | 8      | x | 5      |
| 630              | 8  | x | 8      | x | 4      |
| 631              | 8  | x | 8      | x | 3      |
| 632              | 8  | x | 8      | x | 2-1/2  |
| 633              | 8  | x | 8      | x | 2      |
| 634              | 8  | x | 6      | x | 8      |
| 635              | 8  | x | 6      | x | 6      |
| 636              | 8  | x | 4      | x | 8      |
| 637              | 6  | x | 6      | x | 8      |

Pipe threads shall be in accordance with MIL-DTL-52618.

Pipe thread direction code shall be in accordance with table II.

TABLE II. Thread direction code letter.

| Thread direction code letter | Thread direction     |
|------------------------------|----------------------|
| X                            | Right-hand           |
| Y                            | Left-hand            |
| Z                            | Right- and left-hand |

Finish shall be in accordance with MIL-DTL-52618.

Finish code letter shall be in accordance with table III.

## MIL-DTL-52618/4E

TABLE III. Finish code letter.

| Finish code letter | Finish      |
|--------------------|-------------|
| A                  | As cast     |
| B                  | As extruded |
| C                  | Anodized    |

Part or Identifying Number (PIN). The PIN consists of the letter M, specification sheet number, a dash, configuration code letter, size code numbers, thread direction code letter and finish code letter. PIN's are assigned as follows:

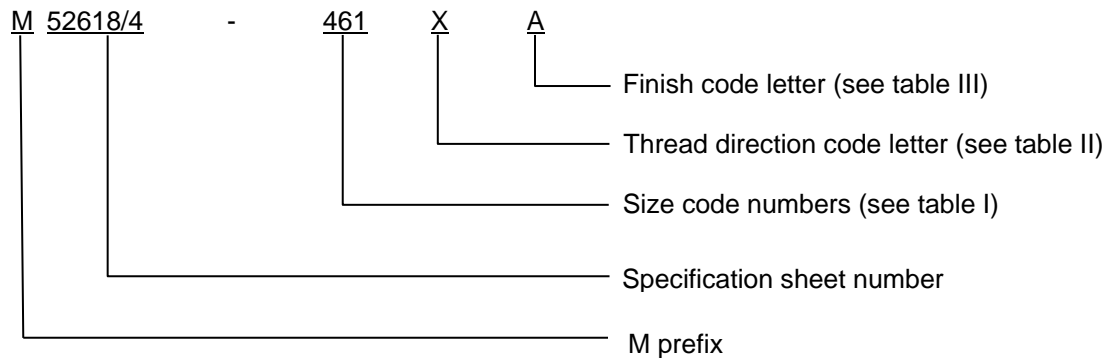

PIN example: M52618/4-461XA indicates a tee 2x2x1, right hand threads, and finish is "as cast".

Changes from previous issue. Marginal notations are not used in this revision to identify changes with respect to the previous issue due to the extent of the changes.

Referenced documents. In addition to MIL-DTL-52618, this document references ASME B16.3.

## CONCLUDING MATERIAL

## Custodians:

Army - AT  
Navy - AS  
DLA - CC

Preparing activity:  
DLA - CC

## Review activities:

Army - CE  
Navy - MC, SA

(Project 4730-2012-013)

NOTE: The activities listed above were interested in this document as of the date of this document. Since organizations and responsibilities can change, you should verify the currency of the information above using the ASSIST Online database at <https://assist.daps.dla.mil>.