

INCH-POUND

MIL-DTL-45913/4B

14 JUNE 2011

SUPERSEDING

MIL-DTL-45913/4A

w/ AMENDMENT 1

2 July 2004

DETAIL SPECIFICATION SHEET

NUT, SELF-LOCKING, HEXAGON

ALL-METAL LOCKING FEATURE, 250°F, UNC/ UNF-3B

This specification is approved for use by all Departments
and Agencies of the Department of Defense.

The requirements for acquiring the product described herein shall consist of this specification sheet and procurement specification MIL-DTL-45913.

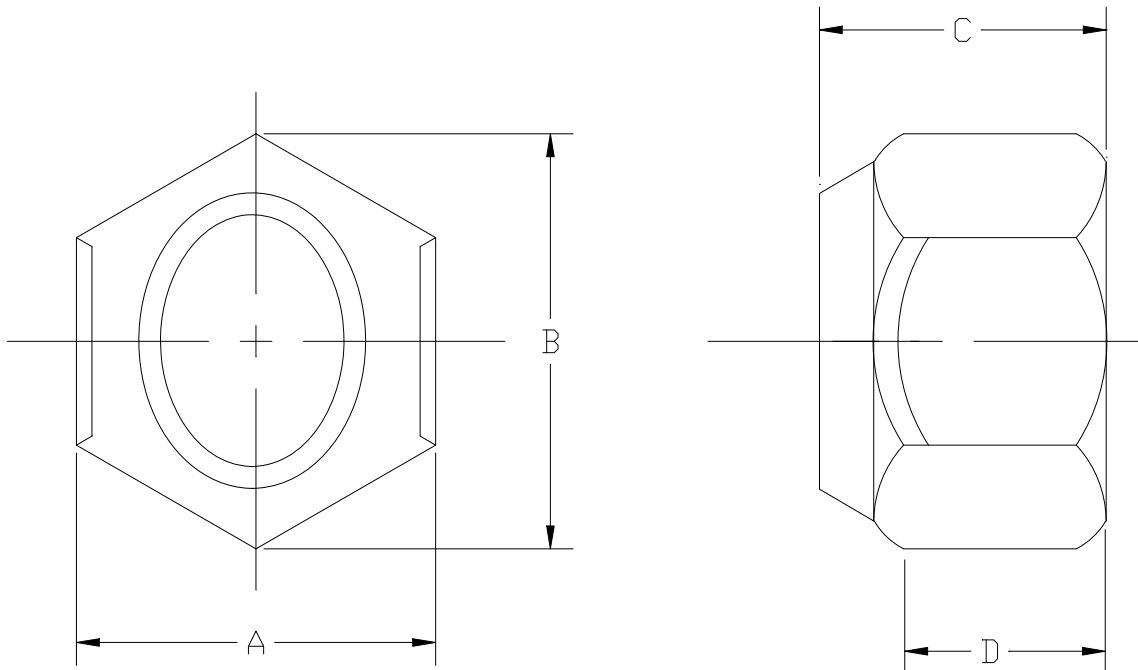

NOTES:

1. All dimensions are in inches.

FIGURE 1. NUT, SELF LOCKING, HEX, ALL-METAL LOCKING FEATURE, UNC/ UNF3B

Comments, suggestions, or questions on this document should be addressed to Defense Supply Center Philadelphia (DSCP), ATTN: DSCP-NASA, 700 Robbins Avenue, Philadelphia, PA 19111-5096 or e-mail to dscpg&ispeccomments@dla.mil. Since contact information can change, you may want to verify the currency of this address information using the ASSIST Online database at <https://assist.daps.dla.mil>.

MIL-DTL-45913/4B

REQUIREMENTS:

1. MATERIAL.

Steel and alloy steel shall be in accordance with SAE J995 grade 5 or 8, as specified in part-number. Corrosion resisting steel (stainless steel) grades 303 and 316, or any alloy in accordance with ASTM F 594, Group 1 or Group 2, shall have a minimum ultimate tensile strength of 70 KSI and shall be non-magnetic. Copper alloy (brass) shall have a minimum ultimate tensile strength of 58 KSI and be of a half hard temper. Aluminum alloy shall have a minimum ultimate tensile strength of 62 KSI.

2. PLATING/FINISH.

Steel and alloy steel locknuts shall be phosphate coated per MIL-DTL-16232 Type Z, Class 2 or cadmium plated per SAE-AMS-QQ-P-416 Type II, Class 2 or 3, or zinc plated per ASTM B633 Type II, Fe/Zn 8 or uncoated plain with a supplementary lubricant which is clean and dry to the touch. Stainless steel locknuts shall be passivated per SAE-AMS 2700, Method 1, Type 6 or 7, Class 1 or black oxide finish per MIL-DTL-13924. Brass locknuts shall be black oxide finished per MIL-F-495, nickel plated per SAE-AMS-QQ-N-290, Class 2, or uncoated plain with a bright finish. Aluminum locknuts shall be anodized clear, no color per MIL-A-8625 (see TABLE II).

3. SURFACE TEXTURE. Shall be 125 microinches Ra in accordance with ASME B46.1.

4. THREADS. Shall be coarse or fine threaded, class 3B, as specified in part-number, in accordance with ASME B1.1.

5. WORKMANSHIP. Parts shall be manufactured and processed with a level of care and workmanship befitting this type of product intended for general purpose military application. Parts shall be free from dirt, grease, loose or deposited foreign materials, sharp edges, burrs, chips, physical malformations or anything that might prevent the part from reliably performing its intended function.

6. PART NUMBER. The part number shall consist of the basic number of this specification sheet, a material code from table II, a dash number from table I, and a finish/plate code (when required) from table II.

EXAMPLE OF PART NUMBER

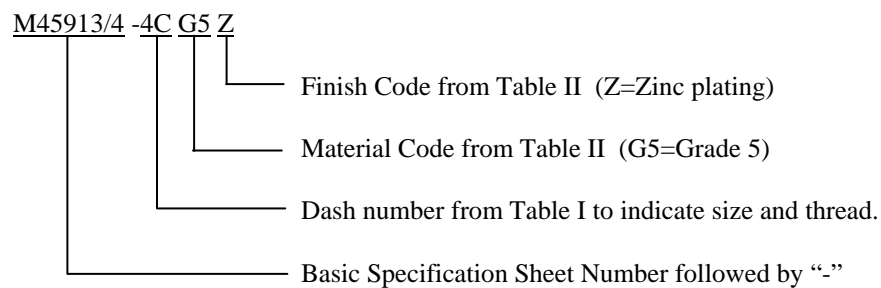

M45913/4-4CG5Z = Nut Self-Locking Hexagon, all-metal locking feature, .250-20 UNC-3B thread, Grade 5 steel, zinc plated.

MIL-DTL-45913/4B

TABLE I. DASH NUMBERS AND DIMENSIONS

Dash No.	Thread Size	A		B	C		D
		Width Across Flats		Corners	Thickness		
		MAX	MIN	REF	MAX	MIN	
00F	.060-80 UNF-3B	.111	.104	.116	.055	.080	.045
01C	.073-64 UNC-3B	.251	.243	.268	.153	.133	.081
01F	.073-72 UNF-3B	.251	.243	.268	.153	.133	.081
02C	.086-56 UNC-3B	.251	.243	.268	.153	.133	.081
02F	.086-64 UNF-3B	.251	.243	.268	.153	.133	.081
03C	.099-48 UNC-3B	.251	.243	.268	.153	.133	.081
03F	.099-56 UNF-3B	.251	.243	.268	.153	.133	.081
04C	.112-40 UNC-3B	.251	.241	.275	.163	.087	.066
04F	.112-48 UNF-3B	.251	.241	.275	.163	.087	.066
05C	.125-40 UNC-3B	.251	.243	.268	.153	.133	.081
05F	.125-44 UNF-3B	.251	.243	.268	.153	.133	.081
06C	.138-32 UNC-3B	.313	.302	.344	.171	.102	.075
06F	.138-40 UNF-3B	.313	.302	.344	.171	.102	.075
08C	.164-32 UNC-3B	.345	.332	.378	.191	.117	.083
08F	.164-36 UNF-3B	.345	.332	.378	.191	.117	.083
010C	.190-24 UNC-3B	.376	.362	.413	.241	.117	.083
010F	.190-32 UNF-3B	.376	.362	.413	.241	.117	.083
012C	.216-24 UNC-3B	.439	.423	.482	.241	.148	.103
012F	.216-28 UNF-3B	.439	.423	.482	.241	.148	.103
4C	.250-20 UNC-3B	.439	.428	.488	.288	.212	.145
4F	.250-28 UNF-3B	.439	.428	.488	.288	.212	.145
5C	.312-18 UNC-3B	.502	.489	.557	.336	.258	.166
5F	.312-24 UNF-3B	.502	.489	.557	.336	.258	.166
6C	.375-16 UNC-3B	.564	.551	.628	.415	.320	.198
6F	.375-24 UNF-3B	.564	.551	.628	.415	.320	.198
7C	.437-14 UNC-3B	.688	.675	.768	.463	.365	.223
7F	.437-20 UNF-3B	.688	.675	.768	.463	.365	.223
8C	.500-13 UNC-3B	.752	.736	.840	.573	.427	.262
8F	.500-20 UNF-3B	.752	.736	.840	.573	.427	.262
9C	.562-12 UNC-3B	.877	.861	.982	.621	.473	.286
9F	.562-18 UNF-3B	.877	.861	.982	.621	.473	.286
10C	.625-11 UNC-3B	.940	.922	1.051	.731	.535	.329
10F	.625-18 UNF-3B	.940	.922	1.051	.731	.535	.329
12C	.750-10 UNC-3B	1.127	1.088	1.240	.827	.617	.382
12F	.750-16 UNF-3B	1.127	1.088	1.240	.827	.617	.382
14C	.875-9UNC-3B	1.314	1.269	1.447	.922	.724	.450
14F	.875-14 UNF-3B	1.314	1.269	1.447	.922	.724	.450
16C	1.000-8UNC-3B	1.502	1.450	1.653	1.018	.831	.513
16F	1.000-12 UNF-3B	1.502	1.450	1.653	1.018	.831	.513
18C	1.125-7UNC-3B	1.689	1.631	1.859	1.176	.939	.576
18F	1.125-12 UNF-3B	1.689	1.631	1.859	1.176	.939	.576
20C	1.250-7UNC-3B	1.877	1.812	2.066	1.272	1.030	.628
20F	1.250-12 UNF-3B	1.877	1.812	2.066	1.272	1.030	.628
22C	1.375-6UNC-3B	2.064	1.994	2.273	1.399	1.138	.681
22F	1.375-12 UNF-3B	2.064	1.994	2.273	1.399	1.138	.681
24C	1.500-6UNC-3B	2.252	2.175	2.480	1.526	1.245	.757
24F	1.500-12 UNF-3B	2.252	2.175	2.480	1.526	1.245	.757

MIL-DTL-45913/4B

TABLE II. MATERIAL AND FINISH CODING

MATERIAL CODE		FINISH CODE	
Steel Grade 5	G5	Cadmium	C
Steel Grade 8	G8	Zinc	Z
Stainless Steel 303	S3	Black Oxide	B
Stainless Steel 316	S6	Nickel	N
Brass	BB	Phosphate	P
Aluminum	AA	Anodized	no code (aluminum only)
		Passivate	no code (stainless only)
		Uncoated	no code

NOTE: See requirement 2 for compatibility of material and finish.

NOTES:

1. Dimensions in inches, unless specified, tolerance: ± 0.016 .
2. Interpret drawing in accordance with ASME Y14.5M.
3. Break all Sharp edged .003 to .005 and remove all burrs and slivers.
4. In the event of a conflict between the text of this document and the references cited herein, the text of this document shall take precedence.
5. Unless otherwise specified, issues of referenced documents are those in effect at the time of solicitation.
6. Changes from previous issue. The margins of this specification are marked with vertical lines to indicate where changes from the previous issue were made. This was done as a convenience only and the Government assumes no liability whatsoever for any inaccuracies in these notations. Bidders and contractors are cautioned to evaluate the requirements of this document based on the entire content irrespective of the marginal notations and relationship to the last previous issue.

Custodians:

Army - AR
Air Force - 99
Navy - OS

Preparing activity
DLA - IS

Review activities:

Army - AT, AV, CR4, EA, GL, MI,
Air Force - 71
Navy - AS, MC

(Project 5310-2011-019)

NOTE: The activities listed above were interested in this document as of the date of this document. Since organizations and responsibilities can change, you should verify the currency of the information above using the ASSIST Online database at <https://assist.daps.dla.mil>.