

INCH-POUND

MIL-DTL-3965H
25 February 2004
SUPERSEDING
MIL-DTL-3965G
9 June 2000

DETAIL SPECIFICATION

CAPACITOR, FIXED ELECTROLYTIC (NONSOLID ELECTROLYTE), TANTALUM,

GENERAL SPECIFICATION FOR

This specification is approved for use by all Departments and Agencies of the Department of Defense.

DO NOT USE FOR NEW DESIGN FOR REPLACEMENT
PURPOSES ONLY AFTER 8 JUNE 1972

1. Scope. This specification covers the general requirements for tantalum, electrolytic (nonsolid electrolyte), fixed capacitors (polarized and nonpolarized), hermetically and nonhermetically sealed (see 1.2.1.7) in metal cases; style CL67 and all tubular-foil styles are insulated (see 6.1). This specification also covers removable counting brackets for use with the CL55-series capacitors.

1.2 Classification.

1.2.1 Part or Identifying Number (PIN). The PIN will be in the following form, and as specified (see 3.1):

CL10	B	C	700	K	P	G
Style (1.2.1.1)	Characteristic (1.2.1.2)	Rated voltage (1.2.1.3)	Capacitance (1.2.1.4)	Capacitance tolerance (1.2.1.5)	Construction (1.2.1.6)	Type of seal (1.2.1.7)

1.2.1.1 Style. The style is identified by the two-letter symbol "CL" followed by a two-digit number, the letters identify tantalum, electrolytic (nonsolid electrolyte), fixed capacitors, and the number identifies a design feature of the capacitor.

1.2.1.2 Characteristic. The characteristic is identified by a single letter "B" that identifies a rated temperature range of -55°C to +85°C. When properly voltage derated (see 3.1), these capacitors will operate up to +125°C.

*

Comments, suggestions, or questions on this document should be addressed to: Defense Supply Center, Columbus, DSCC-VAT, Post Office Box 3990, Columbus, OH 43216-5000 or e-mailed to capacitorfilter@dsc.dla.mil. Since contact information can change, you may want to verify the currency of this address information using the ASSIST Online database at www.dodssp.daps.mil.

MIL-DTL-3965H

1.2.1.3 Rated voltage. The rated voltage is identified by a single letter as shown in table I.

TABLE I. Rated voltage.

Symbol	Rated voltage (-55°C to +85°C)	Symbol	Rated voltage (-55°C to +85°C)
	<u>Volts, dc</u>		<u>Volts, dc</u>
A	3	N	100
B	6	O	250
C	8	P	125
D	10	Q	150
E	15	R	180
F	20	S	270
G	25	T	360
H	30	U	450
I	112	V	540
J	50	W	630
K	60	X	300
L	75	Y	375
M	90	Z	200

1.2.1.4 Capacitance. The nominal capacitance value, expressed in microfarad (μF), is identified by a three-digit number; the first two digits represent significant figures and the last digit specifies the number of zeros to follow. When the nominal capacitance is less than 10 and does not involve fractional values, the first digit will be a zero. When fractional values of a μF , are required, the letter "R" will be used to indicate the decimal point and will be placed where appropriate in the three-digit number. For example: 2R5 represents 2.5 μF , R8 represents 0.8 μF ; and R35 represents 0.35 μF .

1.2.1.5 Capacitance tolerance. The capacitance tolerance is identified by a single letter as shown in table II.

TABLE II. Capacitance tolerance.

Symbol	Capacitance tolerance
	<u>Percent</u>
J	±5
K	±10
L	±15
M	±20
S	+30, -15
T	+50, -15
U	+75, -15

MIL-DTL-3965H

1.2.1.6 Construction. Construction is identified by a single letter as shown in table III.

TABLE III. Construction.

Symbol	Construction
P	Polarized

1.2.1.7 Type of seal. Type of seal is identified by a single letter as shown in table IV.

TABLE IV. Type of seal.

Symbol	Type of seal
G	Hermetic (glass-to-metal)

1.2.2 Type designation of removable mounting brackets. Type designation of removable mounting brackets will be in the following form, and as specified (see 3.1 and 6.2):

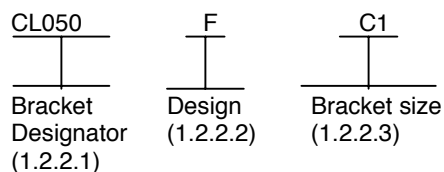

1.2.2.1 Bracket designator. Bracket designator is identified by the two-letter symbol "CL" followed by a three-digit number. The number consists of a zero, followed by two digits applicable to the particular capacitor-case series for which the bracket is intended. For example: CL050 brackets will be used for capacitor style CL55.

1.2.2.2 Design. The bracket design is identified by a single letter "F" for footed bracket and "S" for spade-lug bracket.

1.2.2.3 Bracket size. The bracket size corresponds to the capacitor-case size (see 3.1).

2. APPLICABLE DOCUMENTS

2.1 General. The documents listed in this section are specified in sections 3 and 4 of this specification. This section does not include documents cited in other sections of this specification or recommended for additional information or as examples. While every effort has been made to insure the completeness of this list, document users are cautioned that they must meet all specified requirements of the documents cited in sections 3 and 4 of this specification, whether or not they are listed.

MIL-DTL-3965H

2.2 Government documents.

- * 2.2.1 Specifications, standards, and handbooks. The following specifications, standards, and handbooks form a part of this document to the extent specified herein. Unless otherwise specified, the issues of these documents are those cited in the solicitation or contract (see 6.2).

DEPARTMENT OF DEFENSE

SPECIFICATIONS

- * MIL-DTL-3965/1 - Capacitors, Fixed, Electrolytic (Nonsolid Electrolyte), Tantalum (Polarized, Sintered Slug) - 85°C (Voltage Derated to 125°C) Styles CL14 and CL16.
- * MIL-DTL-3965/19 - Capacitors, Fixed, Electrolytic (Nonsolid Electrolyte), Tantalum (Polarized, Sintered Slug) - 85°C (Voltage Derated to 125°C) Styles CL17 and CL18.
- * MIL-DTL-3965/20 - Capacitors, Fixed, Electrolytic (Nonsolid Electrolyte), Tantalum (Polarized, Sintered Slug) - 85°C (Voltage Derated to 125°C) Styles CL10 and CL13.
- * MIL-DTL-3965/21 - Capacitor, Fixed, Electrolytic (Nonsolid Electrolyte), Tantalum (Polarized, Sintered Slug) - 85°C (Voltage Derated to 125°C) Style CL55.
- * MIL-DTL-3965/24 - Capacitors, Fixed, Electrolytic (Nonsolid Electrolyte), Tantalum (Polarized, Sintered Slug) - 85°C (Voltage Derated to 125°C) Styles CL66 and CL67.
- MIL-PRF-39006 - Capacitor, Fixed, Electrolytic (Nonsolid Electrolyte), Tantalum, Established Reliability, General Specification for.

DEPARTMENT OF DEFENSE

STANDARDS

- * MIL-STD-202 - Standard Electronics and Electrical Component Parts.
- * MIL-STD-810 - Environmental Engineering Considerations and Laboratory Tests.
- * MIL-STD-1276 - Leads for Electronic Component Parts.
- * MIL-STD-1285 - Marking of Electrical and Electronic Parts.
- * (Copies of these documents are available online at <http://assist.daps.dla.mil/quicksearch/> or www.dodssp.daps.mil or from the Standardization Document Order Desk, 700 Robbins Avenue, Building 4D, Philadelphia, PA 19111-5094.)

MIL-DTL-3965H

- * 2.3 Non-Government publications. The following documents form a part of this document to the extent specified herein. Unless otherwise specified, the issues of these documents are those cited in the solicitation or contract.

AMERICAN NATIONAL STANDARDS INSTITUTE (ANSI)

ANSI/NCSL Z540-1 - Calibration Laboratories and Measuring and Test Equipment,
General Requirements for.

- * (Copies of this document may be ordered online at www.ncsli.org or from NCSL International, 1800 30th Street, Suite 305, Boulder, CO 80701-1026)

- * THE INSTITUTE FOR INTERCONNECTING AND PACKAGING ELECTRONIC CIRCUITS INC. (IPC)

J-STD-004 - Soldering Fluxes Requirements for.

- * (Copies of this document can be ordered online at www.ipc.org or from the Institute for Interconnecting and Packaging Electronic Circuits (IPC, INC.), 2215 Sanders Road, Suite 200 south, Northbrook, IL 60062.)

INTERNATIONAL ORGANIZATION FOR STANDARDS (ISO)

ISO 10012-1 - Equipment, Quality Assurance Requirements for Measuring
Part 1: Meteorological Confirmation System for Measuring Equipment.

- * (Copies of this document may be ordered online at <http://webstore.ansi.org/> or from the American National Standards Institute, 11 West 42nd Street, New York, NY 10036-0350.)

2.4 Order of precedence. In the event of a conflict between the text of this document and the references cited herein (except for related associated specifications or specification sheets), the text of this document takes precedence. Nothing in this document, however, supersedes applicable laws and regulations unless a specific exemption has been obtained.

3. REQUIREMENTS

3.1 Specification sheets. The individual item requirements shall be as specified herein and in accordance with the applicable specification sheets. In the event of any conflict between requirements of this specification and the specification sheets, the latter shall govern (see 6.2).

3.2 Qualification. Capacitors and brackets furnished under this specification shall be products which are qualified for listing on the applicable qualified products list at the time set for opening of bids (see 4.4 and 6.3).

3.3 Materials. Materials shall be as specified herein. However, when a definite material is not specified, a material shall be used which will enable the capacitors to meet the performance requirements of this specification. Acceptance or approval of any constituent material shall not be construed as a guaranty of the acceptance of the finished product.

3.3.1 Case. The case shall be of a corrosion-resisting metal or shall be plated or treated to resist corrosion.

3.3.1.1 Sleeving (when applicable). The sleeving shall be of a nonfungus nutrient material. In addition, the material shall not soften, creep, or shrink to a point where any part of the cylindrical portion of the case is left uncovered at any test temperature specified herein.

3.4 Solder and soldering flux. Solder and soldering flux shall be of such quality as to enable the capacitors to meet all of the requirements of this specification.

3.5 Interface and physical dimension requirements. Capacitors shall meet the interface requirements and physical dimensions specified (see 3.1).

MIL-DTL-3965H

3.5.1 Case. Each capacitor shall be enclosed in a hermetically sealed metal case, which will prevent leakage or evaporation of the electrolyte and, in addition, will protect the capacitor element against the entry of contaminants.

3.5.1.1 Sleeving (insulated styles only, (see 3.1)). The sleeving shall extend .016 inch (0.41 mm) minimum, .062 inch (1.57 mm) maximum, beyond each end of the capacitor body; however, if a shrink fitted insulation is used for the sleeving, it shall lap over the ends of the capacitor body.

3.5.2 Terminals.

3.5.2.1 Solder dip (retinning). Only the manufacturer (or his authorized category B distributor) may solder dip/retin the leads of the capacitors supplied to this specification, provided the solder dip process (see appendix C) has been approved by the qualifying activity.

3.5.3 Tin plated finishes. Tin plating is prohibited as a final finish or as an undercoat. Tin-lead (Sn-Pb) finishes are acceptable provided that the minimum lead content is 3 percent (see 6.7).

3.6 Seal. When capacitors are tested as specified in 4.7.2, there shall be no evidence of leakage.

3.7 Dielectric withstanding voltage (style CL55 and insulated styles only, see 3.1).

3.7.1 Style CL55. When capacitors are tested as specified in 4.7.3.1, there shall be no indication of damage or breakdown.

3.7.2 Insulated styles (see 3.1). When capacitors are tested as specified in 4.7.3.2, the sleeving shall withstand the specified potential without breakdown.

3.8 Insulation resistance (style CL55 and insulated styles only, see 3.1). When measured as specified in 4.7.4.1 or 4.7.4.2, the insulation resistance shall be not less than 100 megohms.

3.9 DC leakage. When measured as specified in 4.7.5, the dc leakage shall not exceed the applicable value specified (see 3.1).

3.10 Capacitance. When measured as specified in 4.7.6, the capacitance shall be within tolerance of the nominal value specified (see 3.1).

3.11 Dissipation factor. When determined as specified in 4.7.7, the dissipation factor shall not exceed the applicable percent specified (see 3.1).

3.12 Shock (specified pulse). When capacitors and brackets are tested as specified in 4.7.8, the capacitors shall exhibit no intermittent contacts of 0.5 millisecond or greater duration, or arcing or any open-circuiting or short-circuiting, mechanical damage, or leakage of electrolyte. The brackets shall exhibit no mechanical damage.

3.13 Vibration, high frequency. When capacitors and brackets are tested as specified in 4.7.9, the capacitors shall exhibit no intermittent contacts of 0.5 ms or greater duration, open-circuiting or short-circuiting, mechanical damage, or leakage of electrolyte. The brackets shall exhibit no mechanical damage.

MIL-DTL-3965H

3.14 Thermal shock. When tested as specified in 4.7.10, capacitors and brackets shall meet the following requirements:

a. Capacitors:

DC leakage	Shall not exceed 125 percent of the applicable value specified (see 3.1).
Capacitance	Shall change not more than +5 percent from the initial measured value (see 3.10).
Dissipation factor	Shall not exceed 115 percent of the applicable value specified (see 3.1).
Visual examination	There shall be no evidence of mechanical damage, obliteration of marking, or leakage of electrolyte.

b. Brackets:

Visual examination	There shall be no evidence of mechanical damage or obliteration of marking.
--------------------	---

3.15 Salt atmosphere (for qualification only). When capacitors and brackets are tested as specified in 4.7.11, there shall be no harmful corrosion, and at least 90 percent of any exposed metal surface shall be protected by the finish. There shall be no unwrapping of, or mechanical damage to, the insulating sleeving, when applicable. Marking shall remain legible.

NOTE: Harmful corrosion shall be construed as being any type of corrosion which in any way interferes with the mechanical or electrical performance of the capacitor or mechanical performance of the bracket.

3.16 Solderability (capacitors with axial wire-lead terminals only, see 3.1). When capacitors are tested as specified in 4.7.12, the dipped portion of the terminals shall conform to the solid-wire termination criteria of method 208 of MIL-STD-202.

3.17 Terminal strength. When capacitors are tested as specified in 4.7.13, there shall be no loosening or permanent damage to the terminals, terminal weld or solder, or seal.

3.18 Surge voltage. When capacitors are tested as specified in 4.7.14, there shall be no intermittent contacts, open-circuiting or short-circuiting, mechanical damage, or leakage of electrolyte.

3.19 Moisture resistance. When tested as specified in 4.7.15, capacitors and brackets shall meet the following requirements:

a. Capacitors:

DC leakage	Shall not exceed 125 percent of the applicable value specified (see 3.1).
Capacitance	Shall change not more than the percent specified (see 3.1) from the initial measured value (see 3.10).
Dissipation factor	Shall not exceed 115 percent of the applicable value specified (see 3.1).
Visual examination	There shall be no evidence of harmful corrosion (as defined in 3.15), mechanical damage, obliteration of marking, or leakage of electrolyte.

MIL-DTL-3965H

b. Brackets:

Visual examination	There shall be no evidence of harmful corrosion (as defined in 3.15), mechanical damage, or obliteration of marking.
--------------------	--

3.20 Low temperature (storage). When tested as specified in 4.7.16, capacitors shall meet the following requirements:

DC leakage	Shall not exceed the applicable value specified (see 3.1).
Capacitance	Shall change not more than the percent specified (see 3.1) from the initial measured value (see 3.10).
Dissipation factor	Shall not exceed the applicable value specified (see 3.1).
External examination	There shall be no evidence of leakage of electrolyte.

3.21 Stability at low and high temperatures. When tested as specified in 4.7.17, capacitors shall meet the following requirements:

Step 1 (+25°C):

DC leakage	Shall not exceed the applicable value specified (see 3.1).
Capacitance	Shall be within the applicable tolerance specified (see 3.1).
Dissipation factor	Shall not exceed the applicable value specified (see 3.1).

Step 2 (-55°C):

Impedance	Shall not exceed the applicable value specified (see 3.1).
Capacitance	Shall change not more than the percent specified (see 3.1) from the step 1 measured value.

Step 3 (+25°C):

DC leakage	Shall not exceed the applicable value specified (see 3.1).
Capacitance	Shall change not more than the percent specified (see 3.1) from the step 1 measured value.
Dissipation factor	Shall not exceed the applicable value specified (see 3.1).

Step 4 (+85°C):

DC leakage	Shall not exceed the applicable value specified (see 3.1).
Capacitance	Shall change not more than the percent specified (see 3.1) from the step 1 measured value.
Dissipation factor	Shall not exceed the applicable value specified (see 3.1).

MIL-DTL-3965H

Step 5 (+125°C, see 3.1):

DC leakage	Shall not exceed the applicable value specified (see 3.1).
Capacitance	Shall change not more than the percent specified (see 3.1) from the step 1 measured value.
Dissipation factor	Shall not exceed the applicable value specified (see 3.1).

Step 6 (+25°C):

DC leakage	Shall not exceed the applicable value specified (see 3.1).
Capacitance	Shall change not more than the percent specified (see 3.1) from the step 1 measured value.
Dissipation factor	Shall not exceed the applicable value specified (see 3.1).

3.22 Life at 85°C:

3.22.1 2,000-hour (qualification inspection). When tested as specified in 4.7.18.1, capacitors shall meet the following requirements.

DC leakage	Shall not exceed the applicable value specified (see 3.1).
Capacitance	Shall change not more than the percent specified (see 3.1) from the initial measured value (see 3.10).
Dissipation factor	Shall not exceed the applicable value specified (see 3.1).
Visual examination	There shall be no mechanical damage, obliteration of marking, or leakage of electrolyte.

3.22.2 240-hour (group B inspection). When tested as specified in 4.7.18.2, capacitors shall meet the following requirements:

DC leakage	Shall not exceed the applicable value specified (see 3.1).
Capacitance	Shall change not more than ± 10 percent from the initial measured value (see 3.10).
Dissipation factor	Shall not exceed the applicable value specified (see 3.1).
Visual examination	There shall be no mechanical damage, obliteration of marking, or leakage of electrolyte.

MIL-DTL-3965H

3.22.3 1,760-hour (group C inspection). When tested as specified in 4.7.18.3, capacitors shall meet the requirements specified in 3.23.1.

3.23 Barometric pressure (reduced) (for qualification only). When capacitors are tested as specified in 4.7.19, there shall be no flashover, breakdown, or harmful deformation of the case, and no mechanical damage, obliteration of marking, or leakage of electrolyte.

3.24 Life at 125°C (see 3.1). When tested as specified in 4.7.20, capacitors shall meet the following requirements:

DC leakage (at 125°C and 25°C)	Shall not exceed the applicable value specified (see 3.1).
Capacitance	Shall change not more than the percent specified (see 3.1) from the initial measured value (see 3.10).
Dissipation factor	Shall not exceed the applicable value specified (see 3.1).
Dielectric withstanding voltage (insulated styles only, see 3.1)	Shall be as specified in 3.7.2.
Insulation resistance (insulated styles only, see 3.1)	Shall be as specified in 3.8.
Visual examination of electrolyte.	There shall be no damage, obliteration of marking, or leakage of electrolyte.

3.25 Marking. Unless otherwise specified (see 3.1), capacitors shall be permanently and legibly marked with the type designation, source code, date code, trademark, capacitance (in μF), and rated voltage (at 85°C) as shown in the following example:

Example: CL67BB
 141JPG - Part or Identifying Number (PIN).
 12345 - Source code.
 0340TM - Date code and trademark.
 140 μF 6V - Capacitance and rated voltage (at 85°C).

When applicable, polarity marking shall be as specified (see 3.1). Paper labels shall not be used. Other markings, which in any way interfere with, obscure, or confuse those specified herein, are prohibited. The marking shall remain legible after all tests.

3.25.1 Rated voltage. The rated voltage at 85°C shall be the only voltage marked on the capacitor.

3.25.2 Date and source codes. The date and source codes shall be in accordance with MIL-STD-1285.

3.25.3 Established reliability (ER) marking. An ER part manufactured in accordance with MIL-PRF-39006 may be marked and furnished as a non-ER part to this specification, if produced on the same assembly line or lines and provided it is subjected to and meet all the inspection requirements of the ER part.

3.26 Workmanship. Capacitors and brackets shall be processed in such a manner as to be uniform in quality and shall be free from misaligned welds, cold soldering, harmful corrosion (as defined in 3.15), pits, cracks, dents, rough edges, and other defects that will affect life, serviceability, or appearance.

MIL-DTL-3965H

3.26.1 Solder and soldering flux. Solder and soldering flux shall be of such quality as to enable the capacitors to meet all the requirements of this specification.

3.26.2 Riveting (when applicable). The riveting operation shall be performed carefully to insure that the rivet is tight and satisfactorily headed.

3.26.3 Terminals and end seals. All terminals and end seals shall be free of grease or other foreign material.

3.26.4 Insulating sleeving (when applicable). Insulating sleeving shall fit the container case in such a manner that there are no loose ragged ends.

3.27 AC ripple life at 85°C (when specified, see 3.1). Capacitors shall be tested as specified in 4.7.21, capacitors shall meet the following requirements:

DC leakage (at 125°C and 25°C)	Shall not exceed the applicable value specified (see 3.1).
Capacitance	Shall change not more than the percent specified (see 3.1) from the initial measured value (see 3.10).
Dissipation factor	Shall not exceed the applicable value specified (see 3.1).
Visual examination	There shall be no damage, obliteration of marking, or leakage of electrolyte.

3.28 Recycled, recovered, or environmentally preferable materials. Recycled, recovered, or environmentally preferable materials should be used to the maximum extent possible provided that the material meets or exceeds the operational and maintenance requirements, and promotes economically advantageous life cycle costs.

4. VERIFICATION

4.1 Classification of inspections. The inspections specified herein are classified as follows:

- a. Qualification inspection (see 4.4).
- b. Verification of qualification (see 4.5).
- c. Conformance inspection (see 4.6).
- d. Periodic inspection (see 4.7).

4.2 Test equipment and inspection facilities. Test and measuring equipment and inspection facilities of sufficient accuracy, quality and quantity to permit performance of required inspection shall be established and maintained by the contractor. The establishment and maintenance of a calibration system to control the accuracy of the measuring and test equipment shall be in accordance with ANSI/NCSL Z540-1, ISO 10012-1 or approved equivalent.

4.3 Inspection conditions and methods.

4.3.1 Inspection conditions. Unless otherwise specified herein, all inspections shall be performed in accordance with the test conditions specified in the "GENERAL REQUIREMENTS" of MIL-STD-202.

MIL-DTL-3965H

4.3.2 Methods.

4.3.2.1 AC measurements. AC measurements shall be made at a frequency of 120 \pm 5 hertz (Hz). The magnitude of the ac voltage shall be equal to or less than 1.0 volt root mean square (rms). Except as specified in the following, the dc bias voltage shall be 2.2 +0.0, -1.0 volts for all ac measurements.

- a. At the option of the manufacturer, the dc bias voltage may be 2.2 +0.0, -1.0 V dc or 10 percent of the rated voltage +0.0, -1.0 V dc, whichever is greater, for all styles.

The ratio of ac voltage to dc bias voltage shall be such that no reversal of dc voltage will occur across the capacitor.

4.3.2.2 Reference measurements. When requirements are based on comparative measurements made before and after conditioning, the reference measurement shall be considered the last measurement made at 25°C \pm 5°C prior to conditioning. Unless reference measurements have been made within 30 days prior to the beginning of conditioning, they shall be repeated.

4.3.3 Power supply. The power supply used for life testing shall have a regulation of \pm 2 percent or less of the specified test voltage. The power supply used for dc leakage current measurements shall be stabilized to at least \pm 100 parts per million. No voltage fluctuations shall occur during measurements that would produce a variation in the current measurement.

4.4 Qualification inspection. Qualification inspection shall be performed at a laboratory acceptable to the Government (see 6.3), on sample units produced with equipment and procedures normally used in production.

4.4.1 Sample size. The number of capacitors or brackets to be subjected to qualification inspection shall be as specified in table V or VI as applicable, or in the appendix to this specification.

4.4.2 Inspection routine.

4.4.2.1 Capacitor submission. The sample shall be subjected to the inspections specified in table V, in the order shown. Two sample units shall be subjected to the visual and mechanical examination (internal). The remaining sample units shall be subjected to the subsequent inspections of group I. The sample shall then be divided as specified in table V for groups II to VI inclusive, and subjected to the inspections for their particular group.

4.4.2.2 Bracket submission. Sample units shall be subjected to the qualification inspection specified in table VI, in the order shown. Two sample units of each type represented in a sample shall be subjected to the inspection of group I. The sample units shall then be divided equally into two groups, as specified in table VI and subjected to the inspection for their particular group. Each type of bracket shall be equally represented in each group. Tests on brackets may be performed concurrently with those specified for capacitors in 4.4.2.1.

4.4.3 Failures. Failures in excess of those allowed in table V or VI shall be cause for refusal to grant qualification approval.

MIL-DTL-3965H

TABLE V. Qualification inspection.

Examination or test	Requirement paragraph	Method paragraph	Styles CL14, CL16, CL17, CL18, and CL55		Other styles	
			Number of sample units to be inspected	Number of failures allowed ^{1/}	Number of sample units to be inspected ^{2/}	Number of failures allowed ^{1/}
<u>Group I</u> Visual and mechanical examination (internal) materials, design, construction, and workmanship	--- 3.1, 3.3, 3.5, 3.25, and 3.26	4.7.1	2		2	0
<u>Group I</u> Visual and mechanical examination (internal) materials, design, construction, and workmanship Visual and mechanical examination (external): Physical dimensions, materials, marking ^{3/} , and workmanship	--- 3.1, 3.3, 3.4, 3.25, and 3.26 --- 3.1, 3.3, 3.25, and 3.26	4.7.1 4.7.1	26	0	37	1
Seal ^{1/} Dielectric withstanding voltage (style CL55) Insulation resistance (style CL55) DC leakage Capacitance Dissipation factor	3.6 3.7.1 3.8 3.9 3.10 3.11	4.7.2 4.7.3.1 4.7.4.1 4.7.5 4.7.6 4.7.7				2
<u>Group II</u> Shock (specified pulse) Vibration, high frequency Thermal shock Salt atmosphere	3.12 3.13 3.14 3.15	4.7.8 4.7.9 4.7.10 4.7.11	4		6	1
<u>Group III</u> Solderability (when applicable) Terminal strength Surge voltage Moisture resistance Dielectric withstanding voltage (insulated styles only) Insulation resistance insulated styles only Low temperature (storage)	3.16 3.17 3.18 3.19 3.7.2 3.8 3.20	4.7.12 4.7.13 4.7.14 4.7.15 4.7.3.2 4.7.4.2 4.7.16	4	1	6	1
<u>Group IV</u> Stability at low and high temperatures AC ripple life at 85°C (when specified, see 3.1)	3.21 3.27	4.7.17 4.7.21	4		6	1
<u>Group V</u> Life at 85°C (2,000 hours) Barometric pressure (reduced)	3.22.1 3.23	4.7.18.1 4.7.19	8		12	1
<u>Group VI</u> Life at 125°C	3.24	4.7.20	6	0	6	1

See footnotes at top of next page.

MIL-DTL-3965H

TABLE V. Qualification inspection - Continued.

- 1/ A sample unit having one or more defects shall be considered as a single failure.
 2/ One additional sample unit is included in each sample of 39 units to permit substitution for the failure allowed in group I.
 3/ Marking defects are based on visual examination only and shall be charged only for illegible, incomplete, or incorrect marking.

TABLE VI. Qualification inspection of brackets.

Examination or test	Requirement paragraph	Method paragraph	Number of sample units to be inspected	Number of defectives allowed 1/	
<u>Group I</u> Visual and mechanical examination	3.1, 3.3, 3.5, 3.5.3	4.7.1	2	0	
Material, design, construction, marking and workmanship	3.25.2, 3.25.3, 3.26 and 3.26.2				
<u>Group II</u> Shock (specified pulse) 2/ Vibration, high frequency 2/ Thermal shock Salt atmosphere	3.12 3.13 3.14 3.15	4.7.8 4.7.9 4.7.10 4.7.11	8	1	1
<u>Group III</u> Moisture resistance	3.19	4.7.15	8	1	

1/ A sample unit having one or more defects shall be considered as a single defective.

2/ During shock and vibration tests, one set of each bracket type shall support a capacitor of the same case size with which it is normally used (see 3.1).

4.5 Verification of qualification. The manufacturer shall provide verification to the qualifying activity. Continuation of qualification shall be based on meeting the following requirements:

- a. The capacitor design has not been modified.
- b. Lot rejection for group A inspection does not exceed 10 percent or one lot, whichever is greater.
- c. Periodic group C inspection.
- d. Failure rate levels.

MIL-DTL-3965H

4.6 Conformance inspection.

4.6.1 Inspection of product for delivery. Inspection of product for delivery shall consist of groups A and B inspection (see 4.6.2.1.4).

4.6.1.1 Inspection lot. An inspection lot shall consist of one or more styles of capacitors of either tubular foil, foil package, tubular slug, or slug package construction (see 3.1), produced on the same production line or lines, under essentially the same conditions and offered for inspection during a single work week. The sample selected from a lot shall be representative of the styles and voltages in the lot. Hermetically sealed units shall be kept separate from nonhermetically sealed units. The following style groupings may be used for quality conformance inspection:

Group 1 - CL10, CL13, CL14, CL16, CL17, CL18, and CL55.

Group 2 - CL66 and CL67

4.6.1.2 Group A inspection. Group A inspection shall consist of the examination and tests specified in table VII, in the order shown.

4.6.1.2.1 Sampling plan. The sampling plan for subgroups 1 and 2 shall be as specified in table VII.

TABLE VII. Group A inspection.

Examination or test	Requirement paragraph	Method paragraph	Sampling procedure
<u>Subgroup 1</u>			
DC leakage	3.9	4.7.5	20 samples 0 failures
Capacitance	3.10	4.7.6	
Dissipation factor	3.11	4.7.7	
<u>Subgroup 2</u>			
Visual and mechanical examination (external):	---	4.7.1	13 samples 0 failures
Materials	3.1 and 3.3		
Physical dimensions	3.1		
Marking ^{1/}	3.25		
Workmanship	3.26		
<u>Subgroup 3</u>			
Solderability (when applicable, see 3.1)	3.16	4.7.12	5 samples 0 failures

^{1/} Marking defects shall be based on visual examination only. Any subsequent electrical defects shall not be used as a basis for determining marking defects.

MIL-DTL-3965H

4.6.1.2.2 Rejected lots. The rejected lot shall be segregated from new lots and those lots that have passed inspection. The rejected lot shall be 100 percent inspected for those quality characteristics found defective in the sample and any defective found shall be removed from the lot. A new sample of parts shall then be randomly selected in accordance with table VII. If one or more defects are found in this second sample, the lot shall be rejected and shall not be supplied to this specification.

4.6.1.2.3 Subgroup 3 (solderability).

4.6.1.2.3.1 Sampling plan. Five samples shall be selected randomly from every inspection lot and subjected to the subgroup 3 solderability test. The manufacturer may use electrical rejects from the subgroup 1 screening test for all or part of the samples to be used for solderability testing. If there are one or more defects, the lot shall be considered to have failed.

4.6.1.2.3.2 Rejected lots. In the event of one or more defects, the inspection lot shall be rejected. The manufacturer may use one of the following options to rework the lot:

- a. Each production lot that was used to form the failed inspection lot shall be individually submitted to the solderability test as required in 4.6.1.2.3.1. Production lots that pass the solderability test are available for shipment. Production lots failing the solderability test can be reworked only if submitted to the solder dip procedure in item b.
- b. The manufacturer shall submit the failed lot to a 100 percent solder dip using an approved solder dip process in accordance with 4.7.12. Following the solder dip, the electrical measurements required in group A, subgroup 1 tests shall be repeated on another 20 samples with no defects allowed. Thirteen additional samples shall then be selected and subjected to the solderability test with no defects allowed. If the lot fails this solderability test, the lot shall be considered rejected and shall not be furnished against the requirements of this specification.

4.6.1.2.3.3 Disposition of samples. The solderability test is considered a destructive test and samples submitted to the solderability test shall not be supplied on the contract.

4.6.1.3 Group B inspection. Group B inspection shall consist of the tests specified in table VIII in the order shown, and shall be performed on sample units which have been subjected to and have passed group A inspection.

4.6.1.3.1 Sampling plan. The sampling plan shall be as specified in table VIII.

4.6.1.3.2 Rejected lots. The rejected lot shall be segregated from new lots that have passed inspection. The contractor may rework it to correct the defects, or screen out the defective units, and resubmit for inspection in accordance with table VIII. A new sample of parts shall then be randomly selected in accordance with table VIII. If one or more defects are found in this second sample, the lot shall be rejected and shall not be supplied to this specification. If an inspection lot is rejected under subgroup 3 test, the lot shall not be resubmitted.

4.6.1.3.3 Disposition of sample units. Sample units that have been subjected to subgroup 2 of group B inspection shall not be delivered on the contract or purchase order. Sample units which have been subjected to and have successfully passed subgroups 1 or 3 of group B inspection may be delivered on the contract or purchase order; however, every 12 months ten samples which have successfully passed the test of subgroup 3 shall be tested as specified in 4.6.2.1.

MIL-DTL-3965H

TABLE VIII. Group B inspection.

Test (every 6 months)	Requirement paragraph	Method paragraph	Sampling procedure
Subgroup 1 Dielectric withstanding voltage (Style CL55) Insulation resistance (Style CL55)	 3.7.1 3.8	 4.7.3.1 4.7.4.1	 8 samples 0 failures
Subgroup 2 Stability at low and high temperatures Thermal shock	 3.21 3.14	 4.7.17 4.7.10	 8 samples 0 failures
<u>Subgroup 3</u> Life at +85°C (240 hours)	 3.22.2	 4.7.18.2	 <u>1</u> / 10 samples

1/ One failure allowed.

4.6.2 Qualification verification inspection. Qualification verification inspection shall consist of group C. Except where the results of these inspections show noncompliance with the applicable requirements (see 4.6.2.1.4), delivery of products which have passed groups A and B shall not be delayed pending the results of these qualification verification inspections.

4.6.2.1 Group C inspection. Group C inspection is not required if the manufacturer is qualified to equivalent parts for equivalent established reliability styles in MIL-PRF-39006. Group C inspection shall consist of the tests specified in table IX in the order shown. Group C inspection shall be made on sample units which have passed group A inspection, except that units which are to be subjected to tests of subgroup 5 shall be units which have successfully passed subgroup 3 of table IX (see 4.6.1.3.3).

4.6.2.1.1 Sampling plan. Sample units shall be selected from the first lot and thereafter from every 6 months or every 12 months production as specified in group C inspection table. The voltages selected shall be represented in the sample in the same proportion as the voltages produced during the sampling period. The maximum and minimum case sizes manufactured during the sampling period shall also be represented in the sample in at least the approximate ratio of production.

4.6.2.1.2 Failures. If the number of failures exceeds the number allowed in the group C inspection table IX, the sample shall be considered to have failed.

4.6.2.1.3 Disposition of sample units. Sample units that have been subjected to group C inspection shall not be delivered on the contract or purchase order.

MIL-DTL-3965H

4.6.2.1.4 Noncompliance. If a sample fails to pass group C inspection, the supplier shall take corrective action on the materials or processes, or both, as warranted, and on all units of product which can be corrected and which were manufactured under essentially the same conditions, with essentially the same materials, processes, etc., and which are considered subject to the same failure. Acceptance of the product shall be discontinued until corrective action, acceptable to the Government, has been taken. After the corrective action has been taken, group C inspection shall be repeated on additional sample units (all inspection, or the inspection which the original sample failed, at the option of the Government). Groups A and B inspections may be reinstated; however, final acceptance shall be withheld until the group C reinspection has shown that the corrective action was successful. In the event of failure after reinspection, information concerning the failure and the corrective action taken shall be furnished to the cognizant inspection activity and the qualifying activity.

4.7 Periodic group C inspection.

4.7.1 Visual and mechanical examination. Capacitors shall be examined to verify that the materials, design, construction, physical dimensions, marking, and workmanship are in accordance with the applicable requirements (see 3.1, 3.3, 3.5, 3.26, and 3.27).

CAUTION: CARE SHOULD BE USED IN OPENING AND HANDLING THESE CAPACITORS DURING THE INTERNAL EXAMINATION SINCE SOME OF THE ELECTROLYTES USED ARE DANGEROUS AND MAY CAUSE HARM TO PERSON OR PROPERTY.

4.7.2 Seal (see 3.6). Capacitors shall be tested in accordance with method 112 of MIL-STD-202. When applicable, this test may be performed prior to the addition of the sleeving. The following details shall apply:

- a. Test condition - A or D.
- b. Measurement after test - Not applicable.

4.7.3 Dielectric withstanding voltage (styles CL55 and insulated styles only see 3.1) (see 3.7). Capacitors shall be tested in accordance with method 301 of MIL-STD-202 as specified in 4.7.3.1 or 4.7.3.2.

MIL-DTL-3965H

TABLE IX. Group C inspection.

Test	Requirement paragraph	Test paragraph	Number of sample units to be inspected	Number of failures allowed ^{1/}
<u>Subgroup 1 (every 6 months)</u> Shock (specified pulse) Vibration, high frequency	3.12 3.13	4.7.8 4.7.9 1	12	
<u>Subgroup 2 (every 6 months)</u> Terminal strength Surge voltage Moisture resistance Dielectric withstanding voltage (insulated styles only, see 3.1) Insulation resistance (insulated styles only, see 3.1) Seal (hermetically-sealed styles, (see 3.1)	3.17 3.18 3.19 3.7.2 3.8 3.6	4.7.13 4.7.14 4.7.15 4.7.3 4.7.4.2 4.7.2	12	1
<u>Subgroup 3 (every 6 months)</u> Low temperature (storage) (all styles)	3.20	4.7.16	12	1
<u>Subgroup 4 (every 12 months)</u> Life at 85°C (1,760 hours)	3.22.3	4.7.18.3	10	1
<u>Subgroup 5 (every 12 months)</u> Life at 125°C (see 3.1)	3.24	4.7.20	6	1

^{1/} A sample unit having one or more defects shall be considered as a single failure.

4.7.3.1 Style CL55. The following details and exception shall apply:

- a. Special preparation: The two terminals shall be electrically connected together before application of voltage.
- b. Magnitude of test voltage: 300 volts \pm 10 percent.
- c. Nature of potential: DC.
- d. Points of application of test voltage: Between terminals and case.
- e. Examination after test: Capacitors shall be examined for evidence of damage and breakdown.

4.7.3.2 Insulated styles (see 3.1). The following details and exception shall apply:

- a. Magnitude and nature of test voltage: 2,000 V dc, minimum.
- b. Points of application of test voltage: Between the capacitor case and a V-block in intimate contact with the sleeving.
- c. Examination after test: Insulating sleeving shall be examined for evidence of breakdown.

MIL-DTL-3965H

4.7.4 Insulation resistance (style CL55 and insulated styles only, see 3.1 (see 3.8)). Capacitors shall be tested in accordance with method 302 of MIL-STD-202 as specified in 4.7.4.1 or 4.7.4.2.

4.7.4.1 Style CL55. The following details and exception shall apply:

- a. Test potential: 200 V dc ± 10 percent.
- b. Special preparation: The two terminals shall be electrically connected together before application of voltage and shall remain connected for the insulation resistance measurement.
- c. Points of measurement: Between terminals and case.

4.7.4.2 Insulated style (see 3.1). The following details and exception shall apply:

- a. Test condition: B (500 V dc ± 10 percent).
- b. Points of measurement: Between the capacitor case and a V-block in intimate contact with the sleeving.
- c. Electrification time: 1 minute $+0 -15$ seconds.

4.7.5 DC leakage (see 3.9). DC leakage shall be measured with the dc rated voltage (see 3.1) applied. The electrification period shall be as follows:

- a. For qualification inspection: 5.5 minutes.
- b. For quality conformance inspection: Within 5 minutes.

For nonpolarized capacitors, measurements shall be made in both directions.

NOTE: DC leakage shall always be the first measurement when dc leakage, capacitance, and dissipation factor measurements are made concurrently.

4.7.6 Capacitance (see 3.10). Capacitors shall be tested in accordance with method 305 of MIL-STD-202. The following details shall apply:

- a. Test frequency: As specified in 4.3.2.1
- b. Limit of accuracy: Within 2 percent.
- c. Magnitude of polarizing voltage (bias voltage): As specified in 4.3.2.1.

4.7.7 Dissipation factor (see 3.11). The dissipation factor shall be determined by a polarized bridge. Measurement accuracy shall be within 2 percent.

MIL-DTL-3965H

4.7.8 Shock (specified pulse) (see 3.12). Capacitors and brackets shall be tested in accordance with method 213 of MIL-STD-202. The following details shall apply:

- a. Special mounting means: Capacitors shall be rigidly mounted on a mounting fixture by normal mounting means. 1/ Capacitors with axial wire-lead terminals shall be rigidly mounted on a mounting fixture by the body with their terminals secured to rigidly supported stud-terminals so spaced that the length of each terminal from the capacitor is approximately .375 inch (9.53 mm) when measured from the edge of the supporting stud-terminal. Capacitor terminals shall be within 30 degrees of being parallel. When securing capacitor terminals, care shall be taken to avoid pinching the capacitor terminals.
- b. Test condition: I (100 g's).
- c. Measurement and electrical loading during shock: DC rated voltage (see 3.1) shall be applied to the capacitor during test. Observation shall be made to determine intermittent contact or arcing or open or short-circuiting. Detecting equipment shall be sufficiently sensitive to detect any interruption of 0.5 ms or greater duration.
- d. Examinations after test: Capacitors shall be visually examined for arcing, break down, mechanical damage, and leakage of electrolyte. Brackets shall be visually examined for mechanical damage.

4.7.8.1 Bracket. When brackets alone are being tested, each bracket shall support a capacitor in a case with which it is normally used (see 3.1).

4.7.9 Vibration, high frequency (see 3.13). Capacitors and brackets shall be tested in accordance with method 204 of MIL-STD-202. The following details and exceptions shall apply:

- a. Mounting of specimens: The body of the capacitor shall be rigidly mounted to the vibration-test apparatus. NOTE: The CL50 series capacitors shall be mounted with the appropriate bracket (see 3.1).
- b. Test condition: D (20 g's), with the following exception: For capacitors with axial wirelead terminals, the motion shall be applied for a total of 8 hours (4 hours in each of two mutually perpendicular directions, one parallel and the other perpendicular to the cylindrical axis).
- c. Measurements: During the last 30 minutes of vibration in each direction, an electrical measurement shall be made on the capacitors to determine intermittent contacts or, open or, short-circuiting. Detecting equipment shall be sufficiently sensitive to detect any interruption of 0.5 ms or greater duration.
- d. Examinations after test: Capacitors shall be visually examined for mechanical damage and leakage of electrolyte. Brackets shall be visually examined for mechanical damage.

4.7.9.1 Bracket. When brackets alone are being tested, each bracket shall support a capacitor in a case with which it is normally used (see 3.1).

4.7.10 Thermal shock (see 3.14). Capacitors and brackets shall be tested in accordance with method 107 of MIL-STD-202. The following details and exceptions shall apply:

- a. Conditioning prior to first cycle: 15 minutes at room ambient conditions (see 4.3.1).
- b. Test condition: A, except step 3 shall be +125°C, +7°C, -0°C.
- c. Number of cycles: Capacitors: 30 (see 6.4.2.1).
Brackets: 5
- d. Measurements before cycling: Not applicable.

MIL-DTL-3965H

- e. Measurements after cycling: DC leakage, capacitance, and dissipation factor shall be measured as specified in 4.7.5, 4.7.6, and 4.7.7, respectively. In addition, capacitors shall be externally examined for leakage of electrolyte. Detection of leakage of electrolyte shall be determined by the use of thymol blue or other suitable chemical indicator solution. Brackets shall be visually examined for mechanical damage.

4.7.11 Salt atmosphere (for qualification only) (see 3.15). Capacitors and brackets shall be tested in accordance with method 101 of MIL-STD-202. The following details and exception shall apply:

- a. Applicable salt solution: 5 percent.
- b. Test condition: B (48 hours).
- c. Measurements after test: Not applicable.
- d. Examination after test: After the test, capacitors shall be washed, and then air dried for 24 hours. The capacitors shall then be examined for evidence of harmful corrosion, loss of plating, unwrapping of or mechanical damage to the insulating sleeving (when applicable), and legibility of marking. Brackets shall be visually examined for evidence of harmful corrosion, loss of plating and obliteration of marking.

4.7.12 Solderability (capacitors with axial wire-lead terminals only, see 3.1) (see 3.16). Capacitors shall be tested in accordance with method 208 of MIL-STD-202. The following details shall apply:

- a. Number of terminations of each part to be tested: 2.
- b. Depth of immersion: Terminals shall be immersed up to .062 inch (1.57 mm) of the welded joint or up to .156 inch (3.96 mm) of the body whichever applies.

4.7.13 Terminal strength (see 3.17). All capacitors shall be tested in accordance with 4.7.13.1 and capacitors with solder-lug terminals that show visible bending during this test shall be tested in accordance with 4.7.13.2. Capacitors with screw-thread terminals shall be tested in accordance with 4.7.13.3, and capacitors with axial wire-lead terminals shall be tested in accordance with 4.7.13.4. After the tests, the terminals, terminal weld or solder, and seals shall be examined for loosening or permanent damage.

4.7.13.1 Pull test. Capacitors shall be tested in accordance with method 211 of MIL-STD-202. The following detail and exceptions shall apply:

- a. Test condition: A.
- b. Applied force: 3 pounds +2, -0 ounces for capacitors with axial wire-lead terminals, and 5 pounds +3, -0 ounces for capacitors with solder-lug and screw thread terminals.
- c. Duration of applied force: 30 +5, -0 seconds.

4.7.13.2 Bend test. Capacitors shall be tested in accordance with method 211 of MIL-STD-202. The following detail and exception shall apply:

- a. Test condition: B.
- b. Number of bends: 4.

4.7.13.3 Torque test. Capacitors shall be tested in accordance with method 211 of MIL-STD-202. The following details shall apply:

- a. Test condition: E.
- b. Torque to be applied: 9 pound-inches for No. 6-32 screw-thread terminals, and 20 pound-inches for No. 1/2-20 screw-thread terminals.

MIL-DTL-3965H

4.7.13.4 Wire-lead bend test. The terminal shall be inserted into the hole of the test block fixture and the wingnut shall be tightened (see figure 1). There shall be a minimum of .188 inch (4.78 mm) but not more than .313 inch (7.95 mm) of terminal length between the test block fixture and the end of the case (for terminals with welds more than .188 inch (4.78 mm) from the end of the case, the bottom of the weld shall be flush with the test block fixture). With the fixture firmly supported in a horizontal position, the case shall be forced over in such a manner that the terminal (from end of case to fixture) is maintained in its axial position as closely as practicable while bending the terminal until the end of the case touches the top surface of the fixture. When the case is returned to the starting position, one complete bend will have been completed. The second bend shall be completed in the same manner as the first except that it shall be in the reverse direction. Succeeding bends shall alternate in direction similar to the first and second bends. All terminals shall be subjected to four bends. The rate of bend shall be approximately 5 seconds per bend.

4.7.14 Surge voltage (see 3.18). Capacitors shall be subjected to 1,000 cycles of the applicable dc surge voltage specified (see 3.1). The ambient temperature during cycling shall be 85°C +6°C, -0°C. Each cycle shall consist of a 30 +2, -0 second surge voltage application followed by a 5.5 minute discharge period. Voltage application shall be made through a resistance of 1,000 ±100 ohms including the source in series with the capacitor and the voltage source. Each surge voltage cycle shall be performed in such a manner that the capacitor is discharged through a 1,000 ±100 ohm resistor at the end of the 30 second application. The test shall be terminated on the discharge portion of the cycle. During the test, an electrical measurement shall be made to detect intermittent contacts and open-circuiting and short-circuiting. After the test, capacitors shall be visually examined for mechanical damage and leakage of electrolyte.

4.7.15 Moisture resistance (see 3.19). Capacitors and brackets shall be tested in accordance with method 106 of MIL-STD-202. The following details and exceptions shall apply:

- a. Mounting: Except during examination and measurements, capacitors shall be securely fastened by normal mounting means.
- b. Initial measurements: Not applicable.
- c. Polarization and loading voltage: 6 volts dc or rated voltage, whichever is less.
- d. Step 7b: Vibration is not required during step 7b.
- e. Final measurements: After the final cycle and within 2 to 6 hours after removal of capacitors from the humidity chamber, the dc leakage, capacitance, and dissipation factor shall be measured as specified in 4.7.5, 4.7.6, and 4.7.7, respectively.
- f. Examinations after test: Capacitors shall be visually examined for evidence of harmful corrosion, mechanical damage, obliteration of marking, and leakage of electrolyte. Brackets shall be visually examined for evidence of harmful corrosion, mechanical damage, and obliteration of marking.

4.7.16 Low temperature (storage) (see 3.20). Capacitors shall be tested in accordance with method 502 of MIL-STD-810. The following details and exceptions shall apply:

- a. Pretest data required: DC leakage, capacitance, and dissipation factor measurements obtained from 4.7.5, 4.7.6, and 4.7.7, respectively.
- b. Storage temperature: -62°C +0°C, -3°C.
- c. Exposure time: 72 hours followed by a 1 hour exposure at +125°C, +7°C, -0°C within 24 hours after low temperature storage.
- d. Steps not required: Steps 3, 4, and 5.

MIL-DTL-3965H

- e. Measurements after exposure: Capacitors shall be returned to the inspection conditions specified in 4.3 and within 24 hours after exposure, dc leakage, capacitance, and dissipation factor shall be measured as specified in 4.7.5, 4.7.6, and 4.7.7 respectively.
- f. Examination after test: Capacitors shall be externally examined for leakage of the electrolyte. Detection of leakage of electrolyte shall be determined by the use of thymol blue, or other suitable chemical-indicator solution.

4.7.17 Stability at low and high temperatures (see 3.21). The measurements specified in table X shall be made in the order shown. The capacitors shall be brought to thermal stability before the measurements are made. Thermal stability will have been reached when no further change in capacitance is observed between two successive measurements taken at 15-minute intervals.

4.7.17.1 Impedance. Capacitors shall be conditioned at -55°C $+0^{\circ}\text{C}$, -3°C for a period of not less than 30 minutes or until stable measurements can be obtained. The impedance shall be measured directly or determined from measurements obtained on a bridge. Measurements shall be made at 120 ± 5 Hz. Measurement accuracy shall be within ± 5 percent.

MIL-DTL-3965H

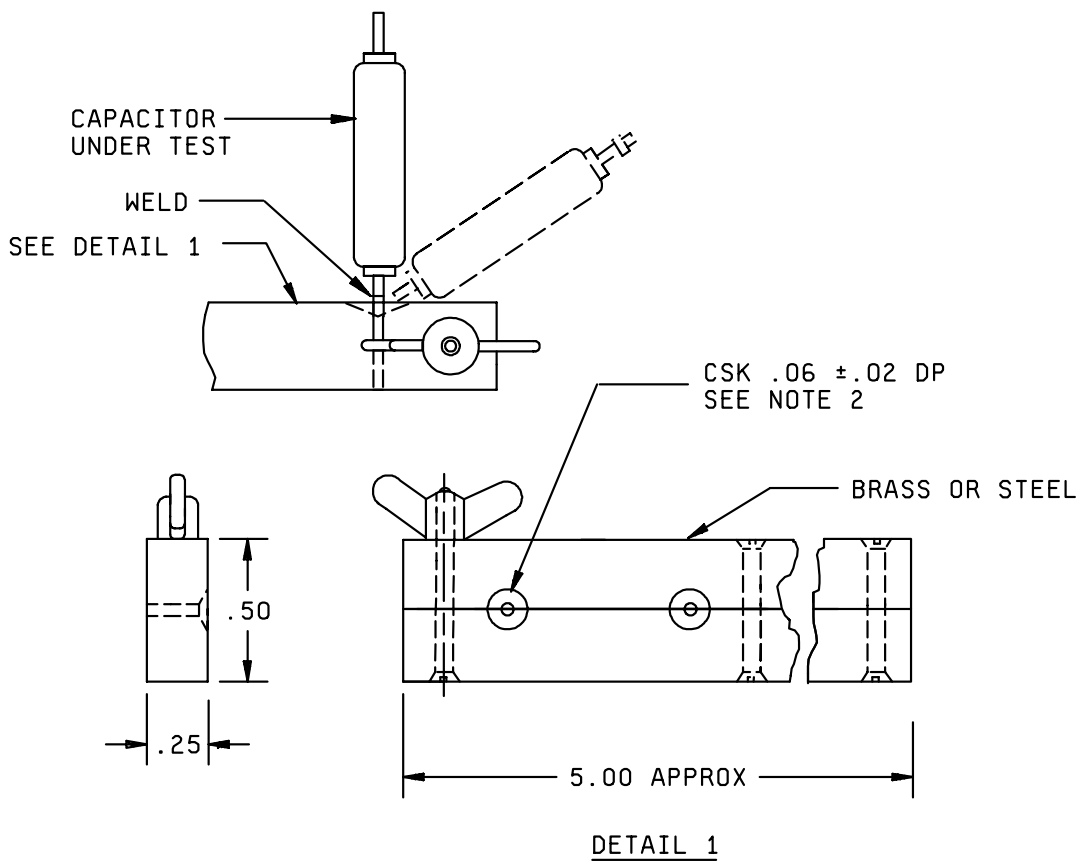

Inches	mm
.02	0.5
.06	1.5
.25	6.4
.50	12.7
5.00	127.0

NOTES:

1. Dimensions are in inches.
2. The diameter of the hole shall be .001 (0.03 mm) less than the diameter of the lead wire (see 3.1).

FIGURE 1. Test block fixture for wire-lead bend test.

MIL-DTL-3965H

TABLE X. Temperature and measurements for stability tests at low and high temperatures.

Step	Temperature	Measurement	Test paragraph
1	+25°C	DC leakage Capacitance Dissipation factor	4.7.5 4.7.6 4.7.7
2	-55°C +0°C, -3°C	Impedance Capacitance	4.7.17.1 4.7.6
3	+25°C	DC leakage Capacitance Dissipation factor	4.7.5 4.7.6 4.7.7
4	+85°C +6°C, -0°C	DC leakage Capacitance Dissipation factor	4.7.5 4.7.6 4.7.7
5	+125°C +7°C, -0°C	DC leakage <u>1/</u> Capacitance Dissipation factor	4.7.5 4.7.6 4.7.7
6	+25°C	DC leakage Capacitance Dissipation factor	4.7.5 4.7.6 4.7.7

1/ During this measurement, derated voltage (see 3.1) shall be applied.

4.7.18 Life at 85°C (see 3.22).

4.7.18.1 2,000-hour (qualification inspection) (see 3.22.1). Capacitors shall be tested in accordance with method 108 of MIL-STD-202. The following details and exceptions shall apply:

- a. Distance of temperature measurements from specimens: Not applicable.
- b. Method of mounting: Wire-lead terminal capacitors shall be mounted by their terminals; all other capacitors shall be mounted by normal mounting means.
- c. Test temperature and tolerance: +85°C +6°C, -0°C.
- d. Operating conditions: DC rated voltage (see 3.1) shall be applied gradually (not to exceed 5 minutes either by a slow build-up of the voltage or through a resistor which shall be shorted out within 5 minutes). Voltage shall be applied continuously except for measurement periods. The impedance of the voltage source, as seen from the terminals of each capacitor, shall not exceed 10 ohms. Storage batteries (or an electronic power supply) capable of supplying at least 100 milliamperes when a capacitor is shorted out shall be used. For nonpolarized capacitors, the voltage shall be reversed every 125 ±10 hours.
- e. Test condition: F (2,000) +72 -0 hours).

MIL-DTL-3965H

- f. Measurements during exposure (at +85°C): DC leakage shall be measured as specified in 4.7.5 during the first hour of exposure and then at 240 +48 -0; 1,000 +48 -0; and 2,000 +72 -0 hours.
- g. Measurements after exposure: Capacitors shall be returned to the inspection conditions specified in 4.3 and dc leakage, capacitance, and dissipation factor shall be measured as specified in 4.7.5, 4.7.6, and 4.7.7, respectively. Capacitors shall then be visually examined for evidence of mechanical damage, obliteration of marking, and leakage of electrolyte.

4.7.18.2 240-hour (group B inspection) (see 3.22.2). Capacitors shall be tested as specified in 4.7.18.1, except that the duration of the test shall be 240 hour.

4.7.18.3 1,760 hours (group C inspection) (see 3.22.3). Capacitors shall be tested as specified in 4.7.18.1, except that the duration of the test shall be 1,760 hours.

4.7.19 Barometric pressure (reduced) (for qualification only (see 3.23)). Capacitors shall be tested in accordance with method 105 of MIL-STD-202. The following details shall apply:

- a. Method of mounting: By normal mounting means.
- b. Test condition: E (150,000 feet).
- c. Test during subjection to reduced pressure: At the end of the conditioning period and with the capacitors still at reduced pressure, the specified voltage (see 3.1) shall be applied for 1 minute \pm 5 seconds.
- d. Test after subjection to reduced pressure: Capacitors shall be visually examined for harmful deformation of the case, mechanical damage, obliteration of marking, leakage of electrolyte, and indications of flashover and breakdown.
- e. Exposure time prior to measurements: 5 minutes (minimum).

4.7.20 Life at +125° C (see 3.1) (see 3.24). Capacitors shall be tested as specified in 4.7.18.1, with the following exceptions:

- a. Test temperature and tolerance: 125°C +7°C -0°C.
- b. Operating conditions: Derated voltage (see 3.1) shall be applied.
- c. Measurements after exposure: Capacitors shall be returned to the inspection conditions specified in 4.3.1, and dc leakage, capacitance, dissipation factor, dielectric withstanding voltage (insulated styles only), and insulation resistance (insulated styles only) shall be measured as specified in 4.7.5, 4.7.6, 4.7.7, 4.7.3.2, and 4.7.4.2, respectively. Capacitors shall then be visually examined for evidence of mechanical damage, obliteration of marking, and leakage of electrolyte.

4.7.21 AC ripple life at 85° C (when specified, see 3.1). Capacitors shall be tested as specified in 4.7.18.1, with the following exceptions:

- a. Operating conditions: Capacitors shall be tested at 40 \pm 2 kHz sinusoidal; current shall be as specified (see 3.1).
- b. Polarizing voltage shall be one-half the rated dc voltage.

MIL-DTL-3965H

5. PACKAGING

- * 5.1 Packaging. For acquisition purposes, the packaging requirements shall be as specified in the contract or order (see 6.2). When packaging of materiel is to be performed by DoD or in-house contractor personnel, these personnel need to contact the responsible packaging activity to ascertain packaging requirements. Packaging requirements are maintained by the Inventory Control Point's packaging activities within the Military Service or Defense Agency, or within the military service's system commands. Packaging data retrieval is available from the managing Military Department's or Defense Agency's automated packaging files, CD-ROM products, or by contacting the responsible packaging activity.

6. NOTES

(This section contains information of a general or explanatory nature that may be helpful, but is not mandatory.)

- * 6.1 Intended use. These capacitors are primarily intended for use in filter, by-pass, and energy storage applications requiring large capacitance values, but where close tolerances are not an important factor and where the alternating current (ac) component of voltage is small compared to the direct current (dc) rated voltage. These capacitors are military unique due to the fact that they must be able to operate satisfactorily in military systems at extreme temperatures of (-55°C to +125°C). These capacitors also are verified under a qualification system. Commercial components are not designed to withstand these military environmental conditions.

6.2 Acquisition documents. Acquisition documents should specify the following:

- a. Title, number, and date of this specification.
- b. Title, number, and date of the applicable specification sheet, and the complete type designation (see 1.2.1 and 3.1).
- c. Required levels of preservation and packing, and special marking (see section 5).

- * 6.3 Qualification. With respect to products requiring qualification, awards will be made only for products that are, at the time of award of contract, qualified for inclusion in Qualified Products List whether or not such products have actually been so listed by that date. The attention of the contractors is called to these requirements, and manufacturers are urged to arrange to have the products that they propose to offer to the Federal Government tested for qualification in order that they may be eligible to be awarded contracts or orders for the products covered by this specification. Information pertaining to qualification of products may be obtained from the Defense Supply Center, Columbus, ATTN: DSCC-VQP, PO Box 3990, Columbus, OH 43216-5000, or by e-mail to vqp.chief@dla.mil.

6.4 Application information.

6.4.1 Life degradation. The life of these capacitors is primarily dependent upon voltage and temperature. When increased life is desired, capacitors may be further derated from the conditions specified in the specification. Under no condition should these capacitors be subjected to voltages above the derated voltage at the maximum rated temperature.

MIL-DTL-3965H

6.4.2 Application information for styles CL10, CL13, CL14, CL16, CL17, and CL18.

6.4.2.1 Thermal shock. When these styles, in application, are not subjected to more than five cycles (see 4.7.10, they may be operated up to 175°C when properly voltage derated (see figure 2).

6.4.2.2 Ripple current. The maximum allowable rms ripple current (in milliamperes) is shown in table XI. The values are for 120 Hz operation over rated temperature (-55°C to +125°C).

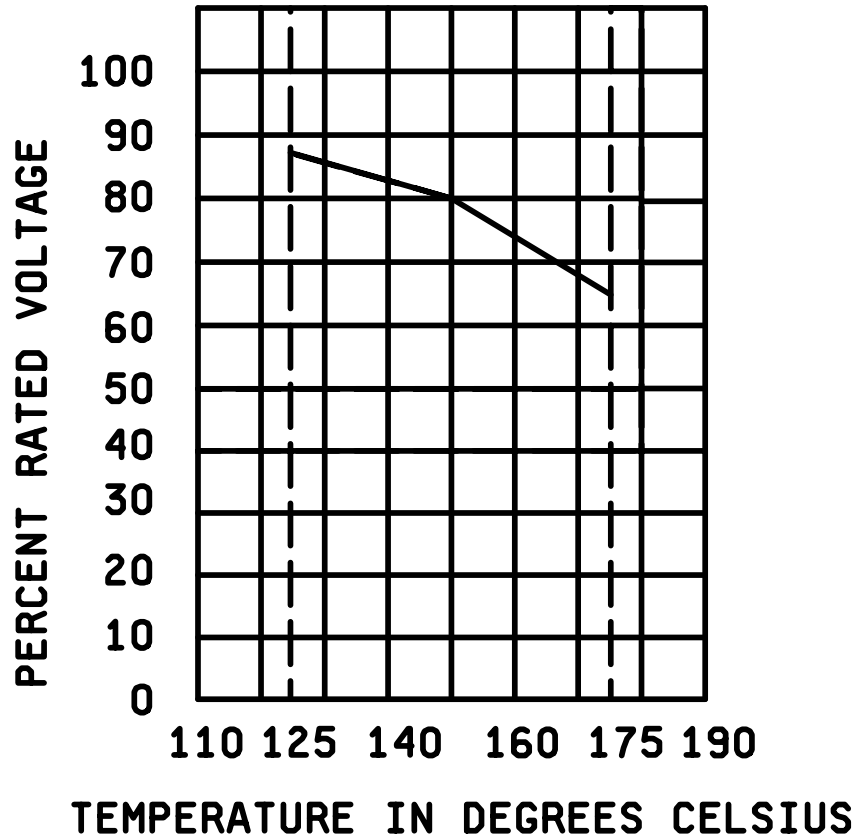

FIGURE 2. Voltage derating with temperature (125°C to 175°C) (styles CL10, CL13, CL14, CL16, CL17, and CL18 only).

MIL-DTL-3965H

TABLE XI. Maximum ripple current.

Style	Rated voltage (85°C)	Capacitance value	Ripple current	Style	Rated voltage (85°C)	Capacitance value	Ripple current
	<u>Volts, dc</u>	<u>μF</u>	<u>mA</u>		<u>Volts, dc</u>	<u>μF</u>	<u>mA</u>
CL10 and CL13	8	70.0	137	CL14 and CL16	450	5.0	252
	8	140.0	213		450	10.0	308
	10	50.0	137		540	4.0	250
	10	100.0	213		540	8.0	308
	20	28.0	137		630	3.5	250
	20	56.0	213		630	7.0	308
	30	20.0	137	CL17 and CL18	30	370.0	550
	30	40.0	213		30	650.0	694
	60	12.0	137		30	1,300.0	694
	60	25.0	213		60	200.0	550
	90	8.0	137		60	350.0	694
	90	16.0	213		60	700.0	694
	180	4.0	117		90	120.0	550
	180	8.0	186		90	220.0	694
	270	2.5	112		90	450.0	694
	270	5.0	179		180	42.0	363
	360	2.0	108		180	60.0	363
360	4.0	175	180		110.0	631	
CL14 and CL16	20	100.0	333		180	230.0	631
	20	200.0	375		270	28.0	339
	30	75.0	333	270	40.0	339	
	30	150.0	375	270	75.0	608	
	60	40.0	333	270	150.0	608	
	60	80.0	375	360	22.0	323	
	90	25.0	333	360	30.0	323	
	90	50.0	375	450	17.0	315	
	180	12.0	282	450	25.0	315	
	180	25.0	341	540	14.0	309	
	270	8.0	266	540	20.0	309	
	270	16.0	320	630	12.0	306	
	360	6.0	258	630	18.0	306	
360	12.0	314					

NOTE: Frequencies other than 120 Hz, the 120 Hz-ripple value should be multiplied by the correction factor as shown on figure 3.

MIL-DTL-3965H

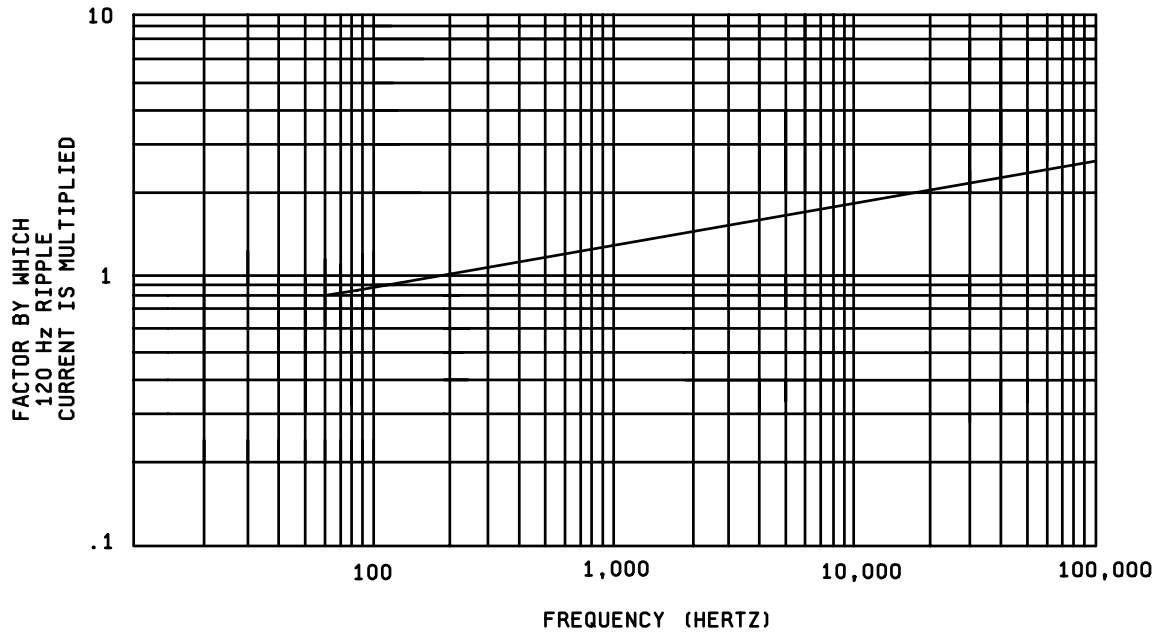

NOTE: A polarizing voltage must be applied to the capacitor which on negative alternations of the ripple voltage will preclude polarity reversal and on positive alternations will not cause the capacitor rated voltage to be exceeded.

FIGURE 3. Ripple current correction factors (styles CL10, CL13, CL14, CL16, CL17 and CL18).

MIL-DTL-3965H

6.5 International Standardization Agreement. Certain provisions of this specification are the subjects of International Standardization Agreement (NEPR No. 16). When amendment, revision, or cancellation of this specification is proposed which will affect or violate the international agreement concerned, the preparing activity will take appropriate reconciliation action through international standardization channels including departmental standardization offices, if required.

6.6 Substitution data. The capacitors specified herein are not for use in new design after the date of this specification. They are authorized for use in design contracts effective on or before the date of this specification, and to support existing military equipment for a cross reference for new design of the substitutability relationship of inactivated styles, see the applicable specification sheet (see 3.1).

6.6.1 Retention of qualification and conformance inspection. For the purpose of retention of qualification and conformance inspection (see 4.5 and 4.6), test data on identical items covered by MIL-PRF-39006 may be used.

6.7 Tin plated finishes. Tin plating is prohibited (see 3.5.4) because it may result in tin whisker growth. Tin whisker growth could adversely affect the operation of electronic equipment systems. For additional information, see ASTM B545, Standard Specification for Electro Deposited Coating of Tin.

6.8 Subject term (key word) listing.

Bracket
Capacitance
Cathode
Tantalum
Vibration

- * 6.9 Environmentally preferable material. Environmentally preferable materials should be used to the maximum extent possible that the material meets or exceeds the operational and maintenance requirements, and promotes economically advantageous life cycle costs. Table VII lists the Environmental Protection Agency (EPA) top seventeen hazardous materials targeted for major usage reduction. If any of these hazardous materials are required, it is recommended that it be used only when other materials cannot meet performance requirements.

TABLE VII. EPA top seventeen hazardous materials.

Benzene	Dichloromethane	Tetrachloroethylene
Cadmium and Compounds	Lead and Compounds	Toluene
Carbon Tetrachloride	Mercury and Compounds	1,1,1 - Trichloroethane
Chloroform	Methyl Ethyl Ketone	Trichloroethylene
Chromium and Compounds	Methyl Isobutyl Ketone	Xylene
Cyanide and Compounds	Nickel and Compounds	

- * 6.10 Changes from previous issues. The margins of this specification are marked with asterisks to indicate where changes from previous issue were made. This was done as a convenience only and the Government assumes no liability whatsoever for any inaccuracies in these notations. Bidders and contractors are cautioned to evaluate the requirements of this document based on the entire content irrespective of the marginal notations and relationship to the last previous issue.

MIL-DTL-3965H

APPENDIX A

QUALIFICATION-SUBMITTAL PLANS

A1 SCOPE

A1.1 Scope. This appendix details the qualification-submittal plans for capacitors and brackets to be subjected to the qualification inspection specified in this specification. These plans specify the sample size, sampling criteria, and limits of coverage for the type of qualification sought. This appendix is a mandatory part of this specification. The information contained herein is intended for compliance.

A2 APPLICABLE DOCUMENTS (This section is not applicable to this appendix.)

A3 SUBMITTAL PLANS

A3.1 Capacitors.

A3.1.1 Single type. The following details apply:

- a. Sample size: As specified in table V.
- b. Sampling criteria: Sample units of the same style, rated voltage, capacitance, capacitance tolerance, seal, and electrolyte.
- c. Limits of coverage: Qualification coverage will be extended to all lower capacitance values and all wider capacitance tolerances than those in the qualified sample, but will not be extended to another style, rated voltage, seal, or electrolyte.

A3.1.2 Voltage-group type. The following details apply:

- a. Sample size: As specified in table XIII.
- b. Sampling criteria: Sample units of (1) the same style, voltage group, capacitance tolerance, seal, electrolyte, and, when applicable, case size, and (2) the highest capacitance value for the lowest rated voltage (see NOTE) and sample units of the highest capacitance value for the highest rated voltage within a single voltage group.

NOTE: For styles CL66 and CL67, voltage group II, low-capacitance series these sample units will be of the highest capacitance value in the voltage group.

- c. Limits of coverage: Qualification coverage will be extended to all intermediate (or lower) voltages in the voltage group, all lower capacitance values, and all wider capacitance tolerances than those in the qualified sample, but will not be extended to another style, voltage group, seal, or electrolyte.

NOTE: When a single rated voltage forms a voltage group, the single-type submittal plan applies.

MIL-DTL-3965H

APPENDIX A

A3.1.3 Combined-style type. The following details apply:

- a. Sample size: As specified in table XIV.
- b. Sampling criteria: Sample units of (1) the same seal, voltage group, and electrolyte, and (2) the combination of styles as specified in table XIV; one style of the highest capacitance value for the lowest rated voltage (see NOTE in A3.1.2b), and the other style of the highest capacitance value for the highest rated voltage within a single voltage group.
- c. Limits of coverage: As specified in A3.2.1c, except that coverage will be extended to both styles.

TABLE XIII. Voltage group submittal data.

Style	Type designation	Sample size	Rated voltage
CL10	CL10BC141TPG	20	8
	CL10BM160TPG	20	90
	CL10BR080TPG	20	180
	CL10BT040TPG	20	360
CL13	CL13BC141TPG	20	8
	CL13BM160TPG	20	90
	CL13BR080TPG	20	180
	CL13BT040TPG	20	360
CL14	CL14BF201UPG	14	20
	CL14BM500UPG	14	90
	CL14BR250UPG	14	180
	CL14BT120UPG	14	360
	CL14BU100UPG	14	450
CL16	CL14BW070UPG	14	630
	CL16BF201UPG	14	20
	CL16BM500UPG	14	90
	CL16BR250UPG	14	180
	CL16BT120UPG	14	360
CL17	CL16BU100UPG	14	450
	CL16BW070UPG	14	640
	CL17BH132MPG	14	30
	CL17BM451MPG	14	90
	CL17BR231MPG	14	180
	CL17BT300MPG	14	360
CL18	CL17BU250MPG	14	450
	CL17BW180MPG	14	630
	CL18BH132MPG	14	30
	CL18BM451MPG	14	90
	CL18BR231MPG	14	180
	CL18BT300MPG	14	360
CL18	CL18BU250MPG	14	450
	CL18BW180MPG	14	630

MIL-DTL-3965H

APPENDIX A

TABLE XIII. Voltage group submittal data - Continued.

Style	Type designation	Sample size	Rated voltage
CL55	CL55BE242MPG	14	15
	CL55BQ181MPG	14	150
CL66 (Low-capacitance series)	CL66BB331JPG	20	6
	CL66BE171JPG	20	15
	CL66BH101JPG	20	30
	CL66BL400JPG	20	75
	CL66BN300JPG	20	100
	CL66BP090JPG	20	125
CL66 (High-capacitance series) ^{1/}	CL66BB561JPG	20	6
	CL66BE271JPG	20	15
	CL66BG181JPG	20	25
	CL66BL560JPG	20	75
	CL66BN430JPG	20	100
	CL66BP250JPG	20	125
CL67 (Low-capacitance series)	CL67BB331JPG	20	6
	CL67BE171JPG	20	15
	CL67BH101JPG	20	30
	CL67BL400JPG	20	75
	CL67BN300JPG	20	100
	CL67BP090JPG	20	125
CL67 (High-capacitance series)	CL67BB561JPG	20	6
	CL67BE271JPG	20	15
	CL67BG181JPG	20	25
	CL67BL560JPG	20	75
	CL67BN430JPG	20	100
	CL67BP250JPG	20	125

1/ Qualification of the high-capacitance series may be the basis for qualification of the low-capacitance series of the same voltage group.

MIL-DTL-3965H

APPENDIX A

TABLE XIV. Combined style submittal data.

Style	Type designation	Sample size	Rated voltage
CL10 and CL13	CL10BC141TPG	20	8
	CL13BM160TPG	20	90
	CL10BR080TPG	20	180
	CL13BT040TPG	20	360
CL14 and CL16	CL14BF201UPG	14	20
	CL16BM500UPG	14	90
	CL14BR250UPG	14	180
	CL16BT120UPG	14	180
	CL14BU100UPG	14	450
	CL16BW070UPG	14	630
CL17 and CL18	CL17BH132MPG	14	30
	CL18BM451MPG	14	90
	CL17BR231MPG	14	180
	CL18BT300MPG	14	360
	CL17BU250MPG	14	450
	CL18BW180MPG	14	630
CL66 and CL67 (Low-capacitance series)	CL66BB331JPG	20	6
	CL67BE171JPG	20	15
	CL66BH101JPG	20	30
	CL67BL400JPG	20	75
	CL66BN300JPG	20	100
	CL67BP090JPG	20	125
CL66 and CL67 (High-capacitance series) 1/	CL66BB561JPG	20	6
	CL67BE271JPG	20	15
	CL66BG181JPG	20	25
	CL67BL560JPG	20	75
	CL66BN430JPG	20	100
	CL67BP250JPG	20	125

1/ Qualification of the high-capacitance series may be the basis for qualification of the low-capacitance series of the same voltage group.

NOTE: When a single rated voltage forms a voltage group, the single-type submittal plan applies.

A3.2 Brackets.

A3.2.1 Single type. The following details apply:

- a. Sample size: As specified in table VI.
- b. Sampling criteria: Sample units of the same type.
- c. Limits of coverage: Qualification coverage will be extended to all smaller brackets of the same basic design, materials and finish.

MIL-DTL-3965H

APPENDIX A

A3.2.2 Combined type. The following details apply:

- a. Sample size: As specified in table IX.
- b. Sampling criteria: Sample units representing a maximum of two types of brackets.
- c. Limits of coverage: Qualification coverage will be extended to all smaller brackets of the same basic design, materials and finish as those in the qualified sample.

TABLE XV. Examples of combined-bracket submission. ^{1/}

Bracket designator	Types to be submitted	Number of sample units
CL050	CL050FC33	9
	CL050SC33	9
	CL050FC33	9
	CL050SD33	9
	CL050SC33	9
	CL050SD33	9

^{1/} This table is set up as a guide; for other combinations, reference is made to the text of this appendix.

MIL-DTL-3965H

APPENDIX B

SOLDER DIP (RETNING) LEADS

B1. SOLDER DIP (RETNING) LEADS

B1.1 Solder dip (retinning). Only the manufacturer (or his authorized category B distributor) may solder dip/retin the leads of the capacitors supplied to this specification, provided the solder dip process (see appendix C) has been approved by the qualifying activity.

B1.2 Solder dip (retinning) leads (axial-wire leads only). Only the manufacturer (or his authorized category B distributor) may solder dip-retin the leads of capacitors supplied to this specification, provided the solder dip process has been approved by the qualifying activity.

B1.3 Qualifying activity approval. Approval of the solder dip process will be based on one of the following options:

- a. When the original lead finish qualified was hot solder dip lead finish 52 of MIL-STD-1276, the manufacturer shall use the same solder dip process for retinning as is used in the original manufacture of the product or one authorized by the manufacturer with approval based on the method outlined in B1.2b.

(NOTE: The 200 microinches maximum thickness requirement is not applicable.)

- b. When the lead finish originally qualified was not hot solder dip lead finish 52 of MIL-STD-1276 as prescribed in 3.5.1.1a, approval for the process to be used for solder dip shall be based on the following test procedure:
 - (1) Thirty samples of the hermetic seal and 30 samples of the nonhermetic seal of any solder process. Following the solder process, the capacitors shall be subjected to the electrical test of group A inspection (including the hermetic seal test if the device is hermetically sealed), with no defects allowed.
 - (2) Ten of the 30 samples shall then be subjected to the solderability test, with no defects allowed.
 - (3) The remaining 20 samples shall be subjected to the resistance to soldering heat test followed by the moisture resistance test (or hermetic seal test if the device is hermetically sealed), with no defects allowed.

B1.4 Solder dip/retinning options. Only the manufacturer (or his authorized category B distributor) may solder dip-retin as follows:

- a. As a corrective action if the lot fails the group A solderability test.
- b. After a group A screening test. Following the solder dip/retinning process, the electrical and seal tests specified in group A, subgroup 1 shall be performed on a 13 piece sample randomly selected from the inspection lot. If there are one or more defects, 100 percent of the lot shall then be subjected to the test(s) from which the defect(s) originated. Following the test(s), the manufacturer shall submit the lot to the group A solderability test as specified in 4.7.12.

MIL-DTL-3965H

Custodians:

Army - CR
Navy - EC
Air Force - 11
DLA - CC

Preparing activity:
DLA - CC

(Project 5910-2237)

Review activities:

Army - AR
Navy - AS, MC, OS, SH
Air Force - 19

* NOTE: The activities listed above were interested in this document as of the date of this document. Since organizations and responsibilities can change, you should verify the currency of the information above using ASSIST Online database at www.dodssp.daps.mil.