

INCH-POUND

MIL-DTL-38449D

09 June 2010

SUPERSEDING

MIL-S-38449C(USAF)

11 June 1976

DETAIL SPECIFICATION

SIGNAL AND SIGNAL/INTERCOMMUNICATION AMPLIFIERS, UNIVERSAL, AERIAL REFUELING

THIS DOCUMENT IS INACTIVE FOR NEW DESIGN

This specification is approved for use by all Departments and Agencies of the Department of Defense.

1. SCOPE

1.1 Scope. This specification covers hydraulic, spring-loaded, normally closed aircraft and missile hydraulic system check valves with operating pressures up to 3,000 pounds per square inch (psi) and operating temperatures from -65° to 450°F.

1.2 Classification. The amplifiers should be of the following classes:

- Class 1 Standard electrical receptacle without intercommunication, PN M38449-1
- Class 2 Miniaturized electrical receptacle without intercommunication, PN M38449-2
- Class 3 Miniaturized electrical receptacle with intercommunication, PN M38449-3
- Class 4 Miniaturized electrical receptacle with intercommunication and push-to-talk, PN M38449-4

Comments, suggestions, or questions on this document should be addressed to Oklahoma City Air Logistics Center/ENSDAA, 3001 Staff Drive, Tinker AFB, OK 73145 or e-mailed to af71@tinker.af.mil. Since contact information can change, you may want to verify the currency of this address information using the ASSIST Online database at <https://assist.daps.dla.mil>.

MIL-DTL-38449D

2. APPLICABLE DOCUMENTS

2.1 General. The documents listed in this section are specified in sections 3, 4, or 5 of this specification. This section does not include documents cited in other sections of this specification or recommended for additional information or as examples. While every effort has been made to ensure the completeness of this list, document users are cautioned that they must meet all specified requirements of documents cited in sections 3, 4, or 5 of this specification, whether or not they are listed.

2.2 Government documents.

2.2.1 Specifications, standards, and handbooks. The following specifications, standards, and handbooks form a part of this document to the extent specified herein. Unless otherwise specified, the issues of these documents are those cited in the solicitation or contract.

FEDERAL SPECIFICATIONS

TT-P-1757 - Primer Coating, Alkyd Base, One Component

DEPARTMENT OF DEFENSE SPECIFICATIONS

MIL-DTL-5541 - Chemical Conversion Coatings on Aluminum and Aluminum Alloys

MIL-R-5757 - Relays, Electromagnetic, General Specification for

MIL-A-8625 - Anodic Coatings for Aluminum and Aluminum Alloys

MIL-DTL-24441/20 - Paint, Epoxy-Polyamide, Green Primer, Formula 150, Type III

MIL-DTL-24441/23 - Paint, Epoxy-Polyamide, Dark Gray R_o1.8, Formula 153, Type III

MIL-R-27521 - Receptacle, Flying Boom, Aerial Refueling General Specification for

MIL-DTL-83723/75 - Connectors, Electrical, (Circular, Environment Resisting), Plug, (Bayonet Coupling, Crimp Socket Contact), (Series III, Classes A, G, K, M, R, T, W and Z)

MIL-DTL-83723/80 - Connectors, Electrical, (Circular, Environment Resisting), Receptacle, (Solder Flange Mount, Bayonet Coupling, Solder Pin Contact), (Series III, Classes H and Y)

DEPARTMENT OF DEFENSE STANDARDS

MIL-STD-130 - Identification Marking of U.S. Military Property

MIL-STD-461 - Requirements for the Control of Electromagnetic Interference Characteristics of Subsystems and Equipment

MIL-STD-704 - Aircraft Electric Power Characteristics

MIL-STD-810 - Environmental Engineering Considerations and Laboratory Tests

MIL-DTL-38449D

MIL-STD-889	-	Dissimilar Metals
MS24266	-	Connectors, Plug, Electrical, Straight, Miniature, Classes E, F, G, and R
MS25231	-	Lamps, Incandescent, Center Contact, Miniature Bayonet Base (T-3-1/4 Bulb)
MS27034	-	Connectors, Receptacle, Electrical, Pin Insert, Cylindrical, Miniature, Hermetic, Solder Mount

DEPARTMENT OF DEFENSE HANDBOOKS

MIL-HDBK-217	-	Reliability Prediction of Electronic Equipment
MIL-HDBK-831	-	Preparation of Test Reports

(Copies of these documents are available online at <https://assist.daps.dla.mil> or from the Standardization Document Order Desk, 700 Robbins Avenue, Building 4D, Philadelphia, PA 19111-5094)

2.3 Non-Government publications. The following documents form a part of this document to the extent specified herein. Unless otherwise specified, the issues of these documents are those cited in the solicitation or contract.

ASME INTERNATIONAL

ASME-Y14.100	-	Engineering Drawing Practices
ASME-Y14.24	-	Types and Applications of Engineering Drawings
ASME-Y14.34M	-	Associated Lists
ASME-Y14.35M	-	Engineering Drawings and Associated Lists

(ASME documents may be obtained online at <http://www.asme.org/> or addressed to ASME International, Three Park Ave., M/S 10E, New York NY 10016-5990.)

ASTM INTERNATIONAL

ASTM-A240/A240M	-	Chromium and Chromium-Nickel Stainless Steel Plate, Sheet, and Strip for Pressure Vessels and for General Applications
ASTM-A666	-	Annealed or Cold-Worked Austenitic Stainless Steel Sheet, Strip, Plate, and Flat Bar
ASTM-B117	-	Salt Spray (Fog) Apparatus, Operating

(ASTM documents may be obtained online at www.astm.org or addressed to American Society for Testing and Material, 100 Barr Harbor Drive, West Conshohocken, PA 19428-2959.)

SAE INTERNATIONAL

SAE-AS31061	-	Connector, Plug, Electric, Straight, Solder Contacts, AN Type
-------------	---	---

MIL-DTL-38449D

SAE-AS117001 THRU AS117040 - Screw – Oval Fillister Head
 SAE-AMS-QQ-A-250 - Aluminum and Aluminum Alloy, Plate and Sheet

(SAE documents may be obtained online at www.sae.org or addressed to the Society of Automotive Engineers, Inc., 400 Commonwealth Drive, Warrendale, PA 15096-0001.)

NATIONAL ELECTRICAL MANUFACTURERS ASSOCIATION (NEMA)

NEMA-HP3 - Electrical and Electronic PTFE (Polytetrafluoroethylene) Insulated High Temperature Hook-Up-Wire; Types ET (250 Volts), E (600 Volts) and EE (1000 Volts)

(NEMA documents may be obtained online at <http://www.nema.org> or addressed to National Electrical Manufacturers Association 1300 North 17th Street, Suite 1847 Rosslyn, Virginia, United States, 22209.)

2.4 Order of precedence. Unless otherwise noted herein or in the contract, in the event of a conflict between the text of this document and the references cited herein the text of this document takes precedence. Nothing in this document, however, supersedes applicable laws and regulations unless a specific exemption has been obtained.

3. REQUIREMENTS

3.1 Qualification. Signal and signal/intercommunication amplifiers furnished under this specification shall be products that are authorized by the qualifying activity for listing on the applicable qualified products list before contract award (see 4.2 and 6.3).

3.2 Recycled, recovered, or environmentally preferable materials. Recycled, recovered, or environmentally preferable materials should be used to the maximum extent possible, provided that the material meets or exceeds the operational and maintenance requirements, and promotes economically advantageous life cycle costs.

3.3 Components. Each class of signal and signal/intercommunication amplifiers (class 1.2.3. or 4) shall comprise a single, assembled unit. The assembled unit, showing maximum dimensions, tolerances, mounting provisions, and electrical receptacle location, is shown on Figure 1.

3.4 Materials. Materials and processes used in the amplifiers shall be of high quality, shall be suitable for the purpose, and shall conform to applicable Government specifications. Mating bearing surfaces of the case and mounting base shall be of corrosion resisting steel, class 301 in accordance with ASTM-A666 and ASTM-A240/A240M or suitably treated to resist corrosion due to fuels, hydraulic fluids, salt fog, or atmospheric conditions likely to be met in storage or service, or these surfaces shall be of hard aluminum alloy in accordance with AMS-QQ-A-250. Heat-treatable aluminum alloys shall not be left in the “0” condition.

MIL-DTL-38449D

3.4.1 Metals. Metals (other than current-carrying parts) shall be of the corrosion-resistant type. The use of any protective coating that will crack or scale with age or extremes of climatic and environmental conditions shall be avoided. Metals shall be inspected in accordance with ASTM-B-117. The use of magnesium or any alloy thereof shall be prohibited.

3.4.1.1 Dissimilar metals. Unless suitably protected against electrolytic corrosion, dissimilar metals shall not be used in intimate contact with each other. Dissimilar metals shall be as defined in MIL-STD-889.

3.5 Design. Each class of amplifier shall perform as an electronically settable three-position switch that advances one position each time an input signal of characteristics specified herein is received and returns to a READY position when power is removed. The three positions are: (1) READY, (2) CONTACT, and (3) DISCONNECT. For each position, electrical circuits of the unit shall provide output power to pin connections as specified in Table I. Valid input signals which advance the unit from READY to CONTACT or CONTACT to DISCONNECT maybe generated by either aircraft. When a valid signal condition occurs, the signal must pass from one aircraft to the other by means of the mated aerial refueling hardware, which contains an electrical link of induction coils and associated air gap. The induction coils transform the electrical signal to a characteristic time voltage function as defined herein. The class 3 and 4 units shall also provide half-duplex voice intercommunication capability between the tanker and receiver aircraft over the same 2-wire circuit used to transmit or receive the READY, CONTACT, and DISCONNECT signals, on a mutually non-interfering basis.

MIL-DTL-38449D

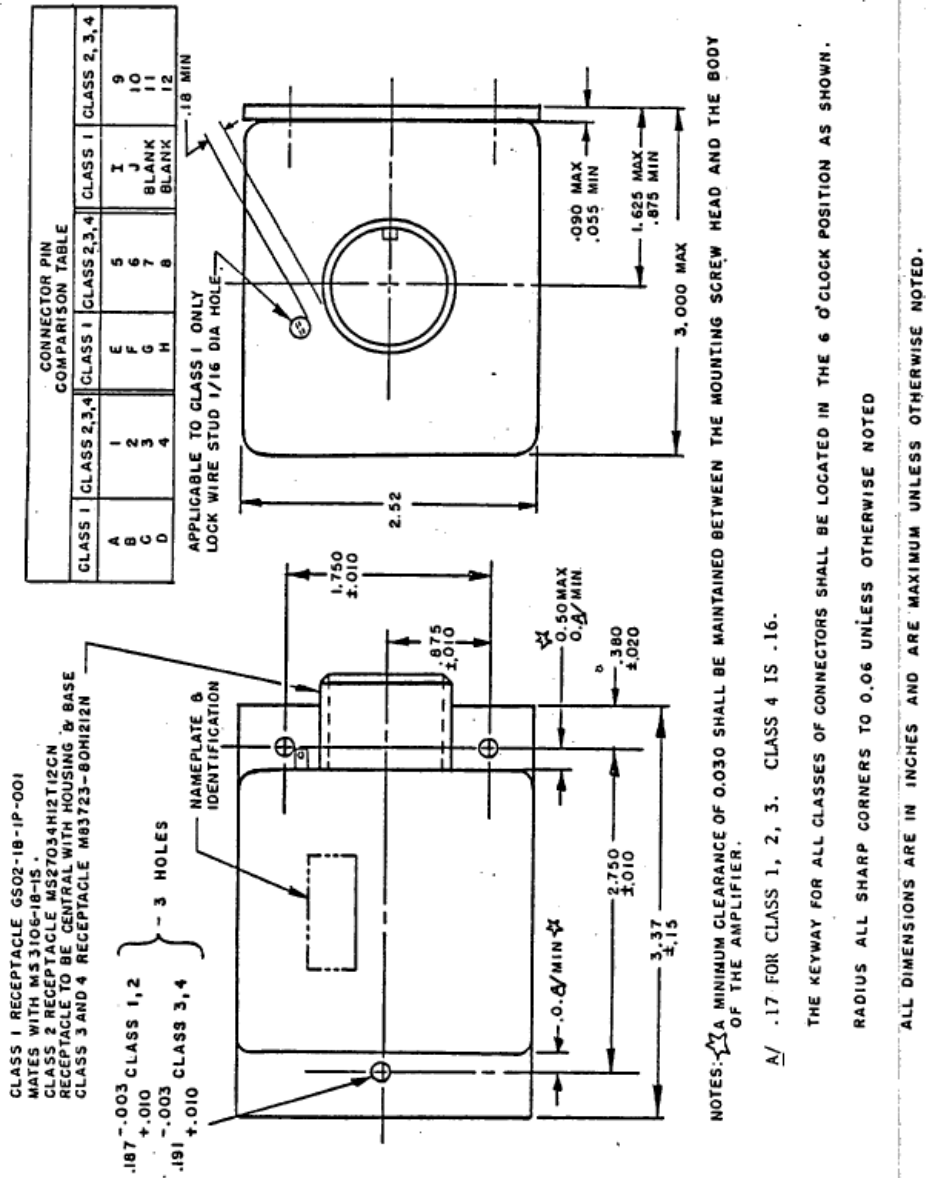

* FIGURE 1. Signal amplifier envelope, mounting and connector.

TABLE I. Pin voltages in the three signal amplifier status.

MIL-DTL-38449D

	Step Sequence		1	2	3	4
	Pin		READY	CONTACT	DISCONNECT	RESET
Pin Function	Class 1	Classes 2, 3 and 4	<u>4/</u>			
Input (pwr)	A	1	28V dc	28V dc	28V dc	0
Ground (Gnd)	B	2	Gnd	Gnd	Gnd	Gnd
Outputs <u>9/</u>	C	3	28V dc	0	0	0
Outputs <u>9/</u>	D	4	0	28V dc	0	0
Outputs <u>9/</u>	E	5	28V dc	0	0	0
Signal input <u>1/</u>	F	6	<u>6/</u> <u>6/ , 7/</u>	<u>6/ , 7/</u>	0	0
Outputs <u>9/</u>	G	7	0	0	28V dc	0
Outputs <u>9/</u>	H	8	28V dc	28V dc	0	0
Outputs <u>2/ 9/</u>	I	9	0	28V dc	28V dc	0
Outputs <u>8/ 9/</u>	J	10	0	28V dc	0	0
Input <u>3/</u>		11	28V dc	28V dc	28V dc	28V dc
Audio(classes 3 and 4 only)		12	Audio Comm	Audio Comm	Audio Comm	Audio Comm

- 1/ In classes 3 and 4, pin 6 also carries the audio intercommunication signals to and from the induction coils.
- 2/ Conditions are for class 1 and 2 units only. Pin 9 is used for the intercommunication (audio) input for the classes 3 and 4.
- 3/ Voltage is applied in the override mode to pin 11 in classes 3 and 4 only.
- 4/ Initial application of power sets the amplifier to READY.
- 5/ Momentary interruption of input power to pin A/1 resets the amplifier to READY.
- 6/ Closing an external circuit between pin F/6 and pin E/5, or applying the first input pulse to pin F/6 shall cause amplifier to go to the CONTACT state.
- 7/ With the amplifier in the CONTACT position, closing an external circuit between pin F/6 and pin D/4 or applying a signal pulse to pin F/6 shall cause the amplifier to go into DISCONNECT.
- 8/ Pin 10 is for push-to-talk for class 4 only (see 3.5.1.8).
- 9/ Reverse voltage protection (diodes) shall be provided internally on all applicable outputs for class 3 and 4. Class 1 and 2 shall use external reverse voltage protection.

3.5.1 Intercommunication amplifier design (classes 3 and 4 only).

MIL-DTL-38449D

3.5.1.1 Signal pulse sensitivity. The signal pulse sensitivity shall be as shown on Figure 2 for the classes 3 and 4 units.

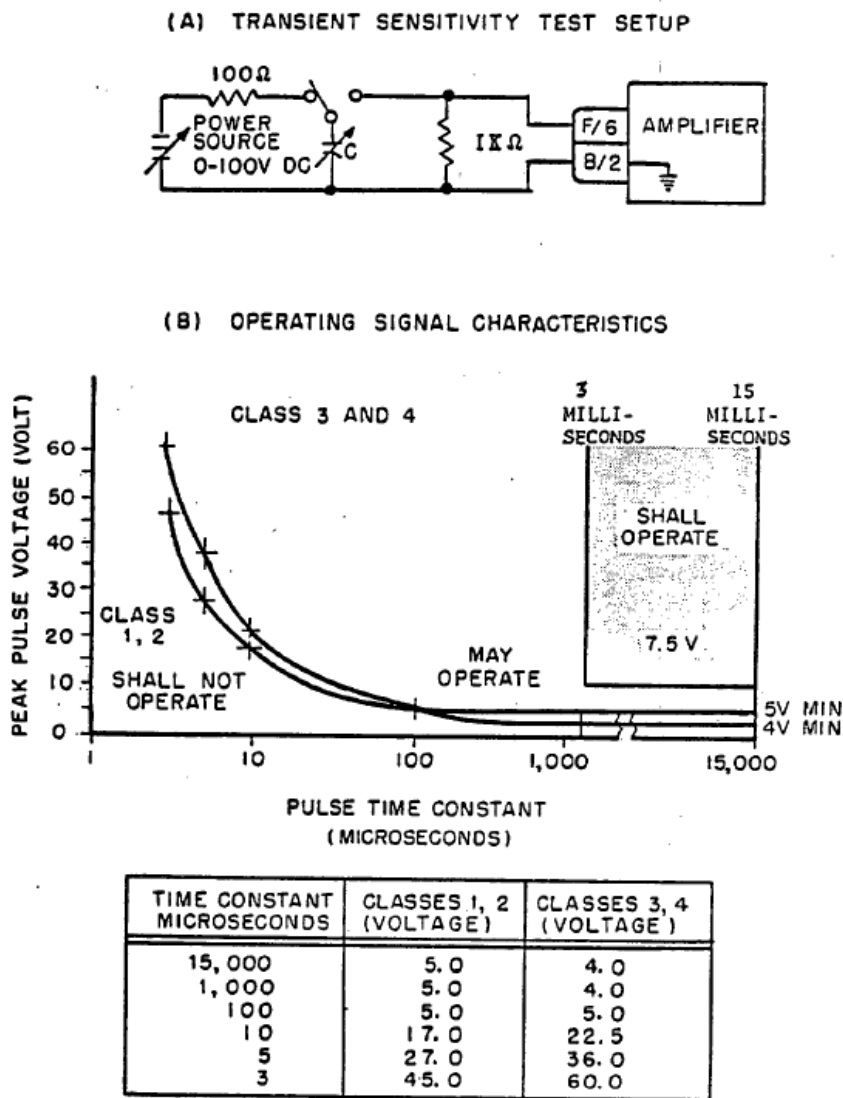

FIGURE 2. Sensitivity test schematic and operating characteristics.

3.5.1.2 Coupling. The intercommunication amplifier circuitry shall be alternating-current coupled to the coil intercommunication circuits to prevent unwanted direct-current bias voltages from appearing in either circuit.

MIL-DTL-38449D

3.5.1.3 Intercom loading. At 1,000 Hz, output pins 9 and 12 (audio and audio common) shall accept any source impedance from 100 ohms to 700 ohms without causing a loading effect on the aircraft intercom of greater than 1 dB.

3.5.1.4 Protection from "talk-off". Design of the intercommunication amplifier shall be such that no intercommunication signal of any amplitude up to 50V peak can cause false switching from the READY to CONTACT, or from the CONTACT to DISCONNECT positions of the signal amplifier.

3.5.1.5 Frequency response. When driving the boom coils or when being driven by another intercommunication amplifier through the boom coils, the intercommunication amplifier frequency response shall be flat to within ± 3 dB over the frequency range of 400 to 3 kHz.

3.5.1.6 Transmitter. The intercom transmitter shall meet the following requirements:

3.5.1.6.1 Attack level. The attack level shall be 0.33V rms, ± 3 dB (-7.4 dBm, ± 3 dB) from 400 Hz to 3 kHz when pin 11 is grounded. With pin 11 connected to 28V dc, the attack level shall be 0.110V rms, ± 3 dB (-16.9 dBm, ± 3 dB).

3.5.1.6.2 Gain. The gain from 400 Hz to 3 kHz shall be as described in Table II.

TABLE II. Transmitter gain.

Condition	Input (Pins 9-12)	Output (Pins 6-12)	Load (Pins 6-12)
Pin 11 to Gnd	0.7 rms (-1 dBm)	0.51V rms, ± 3 dB (-3.6 dBm, ± 3 dB)	100K
Pin 11 to 28V dc	0.25V rms (-10 dBm)	0.575V rms, ± 3 dB (-2.6 dBm, ± 3 dB)	100K

3.5.1.6.3 Transmitter limit level. The transmitter output, when loaded with 100K (pins 6-12), shall be limited to a 3.5V peak with respect to pin 12 (Gnd).

3.5.1.7 Receiver gain. The output at 1,000 Hz under the following conditions shall be 0.26V rms, ± 3 dB (-9.5 dBm, ± 3 dB):

<u>Condition</u>	<u>Input (Pins 6-12)</u>	<u>Load (Pins 9-12)</u>
Pin 11 to Gnd	0.05V rms (-24 dBm)	150 ohms

3.5.1.8 Push-to-talk option. The class 4 amplifier shall have the ability to drive the audio section into either transmit or receive mode by impressing a signal onto pin 10. A positive 28V dc level shall put the amplifier into the receive mode, and a ground shall put the amplifier into the transmit mode. With no signal impressed onto pin 10, the amplifier shall behave as a class 3

MIL-DTL-38449D

unit, except that there will be no output from pin 10. The input impedance at pin 10 shall exceed 10K ohms.

3.5.2 Reliability.

3.5.2.1 Signal pulse amplifier (all classes). The signal pulse amplifier section, which shall be capable of sustaining the cyclic operating conditions specified herein without malfunction or failure, shall have a minimum calculated mean-time-between-failures (MTBF) of 34,000 hours. For purposes of this calculation, the failure rate data of MIL-HDBK-217 shall be used and a component ambient temperature of 70°C shall be assumed.

3.5.2.2 Intercommunication amplifier (classes 3 and 4 only). The intercommunication amplifier section shall have a minimum calculated MTBF of 25,000 hours when the calculation is performed as specified in 3.5.2.1.

3.5.3 Maintainability. No adjustments or maintenance shall be required for the life of either signal pulse or intercommunication amplifier sections.

3.6 Construction. The unit shall be hermetically sealed; all electrical components shall be solid-state where applicable. No vacuum tubes shall be used. Unit construction shall preclude the possibility of any parts working loose in service. The unit shall withstand the strains, jars, vibrations, and other conditions incident to shipping, storage, installation, and service use.

3.6.1 Mounting. The unit shall be mountable in any position to a solid frame. Vibration isolators or shock mounts shall not be used. Three AN117001 screws, oval fillister head, 0.164-32NC-2 (Phillips recess), or commercial equivalent, having a maximum head diameter of 0.27 inch, shall be used for mounting the unit to the airframe. Mounting holes shall be as shown on Figure 1.

3.7 Performance. The amplifiers shall satisfy the following performance requirements:

3.7.1 Function. The unit shall meet the following requirements which shall be demonstrated by tests herein, as required during the qualification testing. The pulse used throughout the functional tests shall be typical of the output pulse of the induction coils. The induction coils necessary for defining this pulse are in accordance with 3.7.2.

3.7.1.1 Input voltages. The unit shall sequence through each position as specified in Table I over any supply voltage from 18.0 to 30.0V dc and with input signal characteristics described in 3.7.1.2, 3.7.1.3, 3.7.1.4, and B of Figure 2.

3.7.1.2 Signal sensitivity (advance). The unit shall advance one position from either READY to CONTACT or from CONTACT to DISCONNECT when a minimum pulse amplitude of 7.5 volts is applied to pin F/6. This pulse shall be applied for not less than 3 milliseconds nor more than 15 milliseconds. (See Figure 2.) The area defined as "May Operate" shall not be used for system design considerations.

MIL-DTL-38449D

3.7.1.3 Signal sensitivity (no advance). A signal input of 5.0V or less (classes 1 and 2) and 4.0V or less (classes 3 and 4) applied to pin F/6 shall not advance the signal pulse amplifier position (see Figure 2).

3.7.1.4 Signal sensitivity (fire thru). The unit shall advance from READY through CONTACT to DISCONNECT with a steady input signal voltage of 7.5V dc or greater on pin F/6.

3.7.1.5 Reset. The amplifier shall be reset whenever the voltage is removed from pin A/1 for 50 milliseconds or longer. The presence of a steady dc voltage of up to 4.5V for classes 1 and 2 or 3.5V for classes 3 and 4 on signal input circuit pin F/6 shall not prevent reset.

3.7.1.6 Response time. Upon receipt of a single input pulse as described in 3.7.1.2, the required change in output (Table 1) shall occur within 50 milliseconds maximum. Upon receipt of a fire-thru signal, the unit shall advance from the READY to DISCONNECT condition in not less than 50 milliseconds and not more than 200 milliseconds under all operating conditions. These time requirements shall be met over the supply voltage range noted in 3.7.1.1. This is demonstrated during the high- and low-voltage functional tests in accordance with 4.4.3.

3.7.1.7 False operation. The unit shall incorporate circuitry in the signal input for damping coupling coil oscillations. The circuit shall prevent multiple sequencing from a single pulse command. Signal output lines (C/3, D/4, E/5, G/7, H/8, and J/10) shall be protected against application of reverse polarity voltages. Protection devices shall be rated at 3 amperes or greater. The signal output diodes shall be tested during production for their proper characteristics (pin 10 has no output for class 4; see 3.5.1.8).

3.7.1.8 Current consumption. A current consumption of 175 milliamperes under no-load conditions shall not be exceeded with the input voltage ranging from 18 to 30V under any of the operating conditions specified herein.

3.7.1.9 Alternate power supply (classes 3 and 4). Circuitry shall be provided so that, when power is removed from pin 1 and applied to pin 11, the intercommunication amplifier shall be energized and the signaling amplifier shall be de-energized.

3.7.2 Compatibility. The units shall function properly when coupled together by induction coils, with maximum misalignments and air gaps as specified by the paragraph entitled, Induction Coil, of MIL-R-27521. Construction of coils shall be as shown on Figure 3 or as approved by the procuring activity.

3.7.3 Interference control. The units shall meet the requirements of MIL-STD-461; however, the relays shall be exempt from the requirements.

(A) TANKER COIL DESIGN

1. The coil shall be made of 2,300 turns #38 B and S Formex magnetic wire or equivalent with the resistance of 333 to 432 ohms.

MIL-DTL-38449D

2. Laminations shall be 0.01 thick commercial quality transformer steel with core loss not exceeding 0.72 watt per pound. The minimum lamination cross-sectional area shall be 0.09 in.² with the pole face dimensions as shown below.

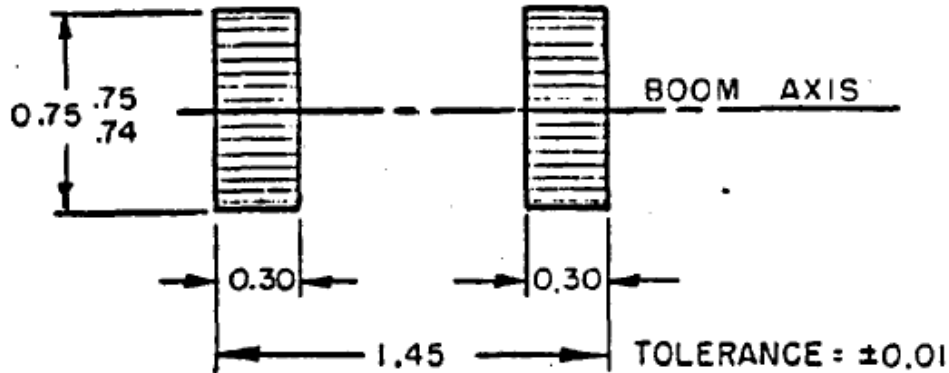

(B) RECEIVER COIL DESIGN

1. The coil shall be made of 2,300 turns #36 B and S Formex magnetic wire or equivalent with a resistance of 396 to 484 ohms.

2. Laminations shall be 0.01 thick commercial quality transformer steel with core loss not exceeding 0.72 watt per pound. The minimum laminations cross-sectional area shall be 0.204 in.² with the pole face dimensions as shown below.

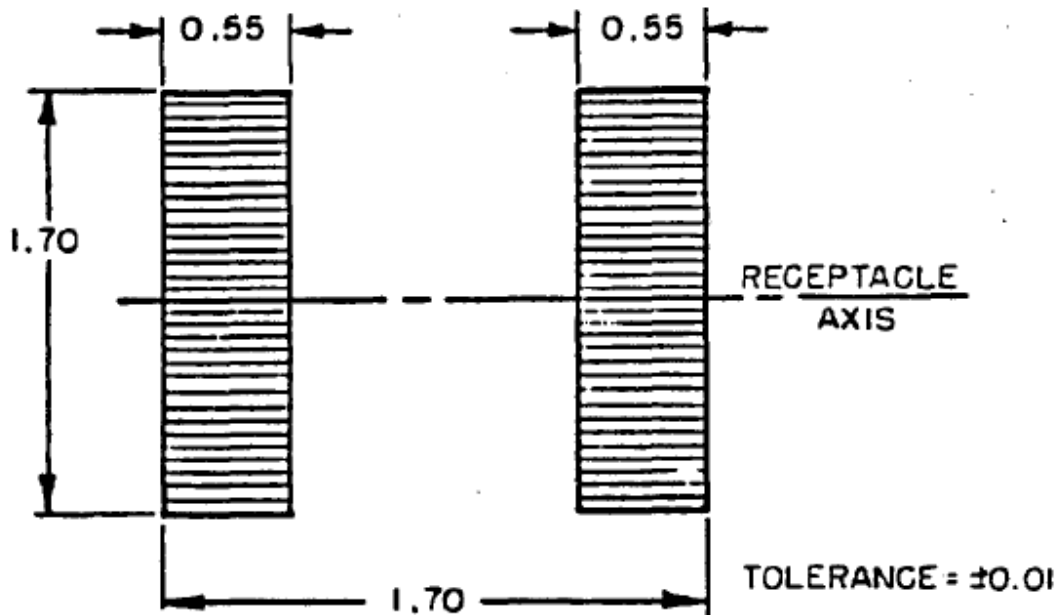

FIGURE 3. Tanker/Receiver coil design.

3.7.4 Dielectric strength. During manufacture and prior to connecting circuit ground to the chassis, the units shall be capable of withstanding application of 1,000V ac (rms) 60 Hz between

MIL-DTL-38449D

all pins (tied together) and the case for a period of 1 minute. Leakage current of 500 microampere or greater shall constitute failure.

3.7.5 Transients and high frequency noise susceptibility.

3.7.5.1 Transients. The units shall be capable of withstanding voltage transients in accordance with the paragraph entitled, Voltage Transients, and Figure entitled, Transient Surge DC Voltage Step Function Loci Limits for Category C Equipment, of MIL-STD-704. The transient may consist of a positive pulse applied to the power input terminals of 80V dc for a duration of 0.04 second, or an equivalent voltage and time function, and as specified herein.

3.7.5.2 Transient sensitivity. The units shall not advance from READY to CONTACT or from CONTACT to DISCONNECT when subjected to voltage and corresponding time factors in the “shall not operate” range of Figure 2.

3.7.5.3 High frequency noise susceptibility. The units shall not advance from READY to CONTACT or from CONTACT to DISCONNECT when the power and signal leads are subjected to high-frequency noise bursts (broad band RF) for a maximum time duration of 1 millisecond and a minimum voltage amplitude of 200V peak-to-peak. These bursts are generally associated with the actuation of reactive solenoids.

3.7.6 Ripple. The units shall be capable of proper operation as specified herein when subjected to the ripple specified in MIL-STD-704, paragraph entitled, Ripple.

3.7.7 Life. The unit shall be capable of being cycled 50,000 times in accordance with 4.4.8 without malfunction or failure of any type.

3.7.8 Environmental. The amplifier shall withstand the following environmental conditions as specified in Section 4 and MIL-STD-810 with no deterioration, deformation, leakage, corrosion, or malfunction:

- a. High temperature
- b. Low temperature
- c. Fungus
- d. Salt fog
- e. Humidity
- f. Shock
- g. Immersion (leakage)
- h. Vibration.

3.7.9 Operating conditions.

MIL-DTL-38449D

3.7.9.1 Temperature altitude conditions. The following are the operating conditions under which the amplifier must function:

- a. Temperature -54° to +71°C
- b. Altitude 0 to 50,000 feet.

3.7.9.2 Non-operating conditions. The following are non-operating conditions which the amplifier shall withstand with no evidence of adverse effects or malfunctions:

- a. Temperature ambient air -62° to +130°C
- b. Altitude 0 to 100,000 feet.

3.8 Electrical components and material.

3.8.1 Receptacle, electrical. The electrical receptacles shall meet the following requirements:

- a. Class 1 – The electrical receptacle shall mate with an MS3106-18-1S connector. Connector and keyway shall be located as shown on Figure 1.
- b. Class 2 – The miniature receptacle shall be in accordance with MS27034H12T12CN. Connector and keyway shall be located as shown on Figure 1 and mate with MS24266R12T12SN.
- c. Classes 3 and 4 - The miniature receptacle shall be in accordance with M83723-80H1212N and shall mate with M83723-75R1212N or MS24266R12T12SN (see 6.1. 1c). The connector and keyway shall be located as shown on Figure 1.

3.8.2 Semiconductors. All semiconductors shall be of a silicon material. Use of nonstandard semiconductor components shall be specifically approved by the procuring activity.

3.8.3 Wiring. All internal wire shall be No. 22 AWG (minimum cross-sectional) in accordance with NEMH-HP3, type E.

3.8.4 Relays. The relays shall be hermetically sealed, balanced armature, crystal can type in accordance with MIL-R-5757, and listed on the associated QPL-5757. Relay contacts shall be rated at 5 amperes resistive and 2.5 amperes inductive.

3.8.5 Input resistance. The unit shall have an input resistance greater than 85K ohms for positive voltages on pin F/6 for all classes.

3.9 Part numbering of interchangeable parts. All parts having the same manufacturer's part number shall be functionally and dimensionally interchangeable. The item identification and part number requirements of ASME-Y14.100, ASME-Y14.24, ASME-Y14.34M, and ASME-Y14.35M shall govern the manufacturer's part numbers and changes thereto.

MIL-DTL-38449D

3.9.1 Interchangeability. The amplifier shall be functionally interchangeable with in-service, tube-type single amplifiers.

3.10 Weight. The total weight of the amplifier shall be not greater than 1 pound.

3.11 Identification of product. The unit shall be marked for identification in accordance with MIL-STD-130. The identification shall be permanent and shall not peel off, crack, or loosen with age and environmental conditions.

3.12 Finish.

3.12.1 Anodizing. All aluminum alloy parts not otherwise protected by suitable plating or painting shall be anodized in accordance with MIL-DTL-5541 or MIL-A-8625.

3.12.2 Paint. The unit shall be primed with one coat of epoxy primer in accordance with MIL-DTL-24441/20 and painted with one coat of black epoxy in accordance with MIL-DTL-24441/23.

3.13 Workmanship. All details of workmanship shall be of sufficiently high grade to insure satisfactory operation and service life. Particular attention shall be given to neatness and thoroughness of soldering, brazing, welding, wire routing that prevents chafing; wiring in accordance with schematic; freedom from blemishes, defects, burrs, sharp edges, loose chips, dirt, or other foreign matter; alignment of parts; and tightness of wire routing, screws, bolts, etcetera.

4. VERIFICATION

4.1 Classification of inspections. The inspection requirements specified herein are classified as follows:

- a. Qualification inspection (see 4.2)
- b. Conformance inspection (see 4.3)

4.2 Qualification inspection (see 6.3).

4.2.1 Test samples. The test samples shall consist of four amplifiers of the particular class being tested. The samples shall be identified with the manufacturer's part number and information as required by the qualifying activity.

4.2.2 Test report and test samples. When tests are conducted at a location other than the laboratory of the qualifying activity, the following shall be furnished to that activity in accordance with contract requirements (see 6.2):

- a. Test report – A report in accordance with MIL-HDBK-831

MIL-DTL-38449D

- b. Test samples – The samples that were tested
- c. Drawings – Two complete sets of outline and electrical schematics identifying all electrical components and values, such as resistor, 2 ohms, etcetera.

4.2.3 Qualification examinations and tests. A qualification test outline, as well as procedures and test setups, shall be submitted to the qualifying activity for the amplifier being tested. Upon receipt of written approval from the qualifying activity, the manufacturer may then proceed with the testing portion of qualification. The qualification inspection shall consist of all the examinations and tests described under 4.4 and shall be conducted in the sequence listed below (see 6.3):

Amplifier Unit No. 1

- a. Examination of product (see 4.4.1).
- b. Dielectric strength (see 4.4.2).
- c. Functional test (see 4.4.3).
- d. Ripple test (see 4.4.4).
- e. Transient sensitivity (see 4.4.5).
- f. Transient and noise susceptibility (see 4.4.6).
- g. High temperature (see 4.4.7.1).
- h. Low temperature altitude (see 4.4.7.2).
- i. Fungus (see 4.4.7.3).
- j. Salt fog (see 4.4.7.4).
- k. Humidity (see 4.4.7.5).
- l. Shock (see 4.4.7.6).
- m. Immersion (leakage) (see 4.4.7.7).

Amplifier Unit No. 2

- a. Examination or product (see 4.4.1).
- b. Dielectric strength (see 4.4.2).

MIL-DTL-38449D

- c. Functional test (4.4.3).
- d. Ripple test (see 4.4.4).
- e. Transient sensitivity (see 4.4.5).
- f. Transient and noise susceptibility (see 4.4.6).
- g. Vibration (see 4.4.7.8).
- h. Life (see 4.4.8).
- i. Radio frequency interference (see 4.4.9).

Amplifier units No. 3 and No. 4 shall be provided to the qualifying activity for flight evaluation as specified in 4.5. Units No. 3 and No. 4, prior to submission, shall have successfully completed the individual inspections as specified in 4.3.1.

4.3 Quality conformance inspection. Quality conformance inspection shall consist of the individual inspections described below:

4.3.1 Individual inspections. Each amplifier shall be subjected to the following examination and tests as described under 4.4:

- a. Examination of product (see 4.4.1).
- b. Dielectric strength (see 4.4.2).
- c. The following functions tests of 4.4.3 as specified in Table III:
 - (1) High voltage – steps 1 through 8 only.
 - (2) Low voltage – steps 1 through 8 only of the high voltage test.
 - (3) False operation (diode) test.
 - (4) Current consumption.
 - (5) Transmitter tests (classes 3 and 4 at 1,000 Hz only).
 - (6) Receiver test (classes 3 and 4 at 1,000 Hz only).
 - (7) Intercom loading (classes 3 and 4 at 1,000 Hz only).
- d. Noise susceptibility (see 4.4.6.2).

MIL-DTL-38449D

e. Immersion (leakage) (see 4.4.7.7).

TABLE III. Functional test.

Test	Control or Switch Positions	Observation <u>1/</u> <u>2/</u>
HIGH VOLTAGE	Set power supply to 30 +0, -.5V dc S5 in DC position S6 in OFF position	
1. READY Condition	No switches activated	Lamps A, C, E, & H ON -- All others OFF
2. CONTACT Condition	Momentarily close S1	Lamps A, D, H, I, & J ON -- All others OFF
3. DISCONNECT Connection	Momentarily close S2	Lamps A, G, & I ON -- All others OFF
4. RESET	Momentarily open S3	Lamps A, C, E, & H ON -- All others OFF
5. FIRE THRU	Momentarily close S4	Lamps A, G, & I ON -- All others OFF
6. RESET	Momentarily close S3	Lamps A, C, E, & H ON -- All others OFF
7. SENSITIVITY (NO ADVANCE)	Set S5 to PULSE position and signal level control to 5.0 +0, -.1V (classes 1 and 2); 4.0 +0, -.1V (classes 3 and 4)	
(a) Steady signal	Close S6 and reopen	Lamps A, C, E, & H remain ON -- All others OFF

MIL-DTL-38449D

TABLE III. Functional test – Continued.

Test	Control or Switch Positions	Observations <u>1/</u> <u>2/</u>
8. SENSITIVITY (ADVANCED)	Set signal level control to 0V	
(a) Steady signal	Close S6 and slowly increase voltage	Unit shall fire thru (Lamps A, G, & I ON) between 5.1 & 7.5V (classes 1 and 2); 4.1 & 7.5V (classes 3 and 4) Record value.
	Adjust control for signal level of 4.5 +.1, -0V (classes 1 and 2); 3.5 -.1, -0V (classes 3 and 4) Reset using S3	Lamps A, C, E, & H ON
(b) Pulse, 3 ms	Open S6 and set control for 7.5 +0, -.1V Close S7 momentarily Close S7 Momentarily again	Lamps A, D, H, I, & J ON Lamps A, G, & I ON
(c) Pulse, 15 ms	Reset using S3 Close S8 momentarily Close S8 momentarily again RESET	Lamps A, C, E, & H ON Lamps A, D, H, I, & J ON Lamps A, G, & I ON
9. RESPONSE TIME	Set S5 to DC position Connect timer or counter with start input on TP 1 and stop input on TP 2. With unit in RESET condition, momentarily close S1.	Timer shall indicate less than 50 ms response time between input (start) signal on TP 1 and output at TP 2. (Pin J)
10. DELAY TIME	Connect timer or counter with start input on TP 1 and stop input on TP 3. With unit in RESET condition momentarily close S4. RESET	Timer shall indicate a duration of from 50 to 200 ms. Lamps A, G, & I ON Lamps A, C, E, & H ON
LOW VOLTAGE	Set power supply to 18 +.5, -0V S5 in DC position S6 on OFF position Repeat steps 1 through 10 of High Voltage Test in this table.	Results and limits are identical to High Voltage test.

MIL-DTL-38449D

TABLE III. Functional test – Continued.

Test	Control or Switch Positions	Observations <u>1/</u> <u>2/</u>
FALSE OPERATION	Insulate amplifier from bench ground. Adjust supply 30 ±0. -5V with unit in RESET condition operate S9.	Observe and measure the voltage across lamp G to be greater than 20 dc
CURRENT CONSUMPTION	Actuate S13 and measure and record the no-load of READY, CONTACT, and DISCONNECT current consumption of the unit at room temperature unless otherwise specified. Adjust the supply voltage to 18 +.5, -0V and hold for 2 seconds minimum Repeat for a supply voltage of 30 +0, -5V	Current draw shall not exceed 150 milliamperes for either relay position (classes 1 and 2); 175 milliamperes (classes 3 and 4)
TRANSMITTER TEST (Classes 3 and 4)	See 4.4.6.3.1.	See 3.5.1.6.
RECEIVER TEST (Classes 3 and 4)	See 4.4.6.3.2.	See 3.5.1.7.
INTERCOM LOADING (Classes 3 and 4)	See 4.4.6.3.3.	See 3.5.1.3.

1/ Lamp I does not come ON when testing a class 3 or 4 unit.

2/ Lamp J does not exist for class 4 units.

4.4 Inspection methods.

4.4.1 Examination of product. Each amplifier shall be subjected to inspection for dimensional requirements as shown on Figure 1 and shall be examined to determine conformance to the requirements of this specification with respect to materials, design, interchangeability, weight, finish, identification, workmanship, construction, and the electrical receptacle. The above shall be noted and recorded.

4.4.2 Dielectric strength. The dielectric strength test shall be conducted prior to, sealing the unit. The ground connection between the case of the unit and circuit ground (Pin B/2), including radio frequency interference bypass components if applicable, shall be opened. One thousand volts ac, 60 Hz shall be applied between all pins (tied together) and the case of the unit for a period of 1 minute. Evidence of breakdown, arc-over, or current flow that is transient, fluctuating, steadily increasing, or evidence of leakage current of 500 microamperes or more shall constitute failure.

MIL-DTL-38449D

4.4.3 Functional test. The tests of Table III shall be performed when required during qualification testing as specified and at the conclusion of the tests of 4.4.6.1, 4.4.7.1, 4.4.7.2, 4.4.7.8, 4.4.8, 4.4.7.3, 4.4.7.4, 4.4.7.7, 4.4.7.6, and 4.4.7.5. The test shall be conducted using a test circuit similar to that shown on Figure 4 and as specified in 3.7.1. Instrument accuracy shall be demonstrated by repeating instrument readouts per test. All tests results shall be recorded.

4.4.4 Ripple test. This test shall be conducted in accordance with the paragraph entitled, Ripple, and Figure entitled, Frequency Characteristics of Ripple in 28 Volt DC Electric System, of MIL-STD-704. The specified voltage levels and frequencies shall be inductively coupled in series with the positive power input terminals. The unit shall be functionally tested as specified in 4.4.3 during application of the specified ripple voltages.

4.4.5 Transient sensitivity. Transient sensitivity shall be performed as shown on Figure2(A). Capacitor C shall be charged to the supply voltage and switched to the amplifier input. The supply voltage shall be varied, and the minimum peak voltage required to trigger the amplifier shall be determined. The minimum voltage at each of the following time constants shall be plotted. Figure 2(B) depicts the minimum allowable voltage the unit shall operate in the “may operate range” and the “shall operate” range.

- a. 3 microseconds (usec)
- b. 5 usec
- c. 10 usec
- d. 100 usec
- e. 1,000 usec
- f. 15,000 usec

4.4.6 Transient and noise susceptibility tests.

4.4.6.1 Transient test. This test shall be in accordance with the paragraph entitled, Voltage Transients, and Figure entitled, Transient Surge DC Voltage of Step Function Loci Limits for Category C Equipment, of MIL-STD-704. A rectangular pulse, 0.04 second in duration, rising from 24V to 80V dc shall be applied h the input power terminals. The functional test specified in 4.4.3 shall be conducted during application of transients.

4.4.6.2 Noise susceptibility. The unit shall be subjected to a test in accordance with the steps outlined below and Figure 5, or an equivalent test meeting the requirements set forth in 3.7.5.3:

- a. Power supply shall be set for 28V dc.
- b. Switch S2 shall be closed, and amplifier shall come ON in READY position, with DS1 lighted.

MIL-DTL-38449D

- a. Replace the system simulator with a 100K-ohm fixed carbon resistor connected, in parallel with a vacuum tube voltmeter (VTVM), or equivalent, between pins 6 and 12.
- b. An audio oscillator operating at 1 kHz shall be connected across pins 9 and 12, and its output set to less than 25 millivolts rms (-30 dBm).
- c. With pin 11 grounded to pin 2, oscillator output shall be slowly increased until the VTVM provides an indication.
- d. The VTVM shall be disconnected from pins 6 and 2 and connected across the oscillator. The indicated voltage level shall be recorded as the attack level (0.33V rms, ± 3 dB; -7.4 dBm, ± 3 dB).
- e. Oscillator output shall be set to 0.7V rms (-1 dBm, 1,000 Hz), and the output voltage across pins 6 and 2 (0.5 IV rms, ± 3 dB; -3.6 dBm, ± 3 dB) shall be checked. This shall be repeated at frequencies of 400 Hz and 3,000 Hz. The output across pins 6 and 2 shall be within 3 dB of the 1,000 Hz level.
- f. Steps a through e shall be repeated with pin 11 connected to 28V dc except that:
 - (1) Attack level shall be 0.11V rms ± 3 dB (-16.9 dBm, ± 3 dB).
 - (2) Oscillator output shall be set to 0.25V rms (-10 dBm).
 - (3) Output noted across pins 6 and 2 shall be 0.575V rms, ± 3 dB (-2.6 dBm, ± 3 dB).
- g. With pin 11 connected to 28V dc, oscillator output shall be increased to 4V rms. Using an oscilloscope the peak output across pins 6 and 2 shall be checked and shall be less than 3.5V.

4.4.6.3.2 Receive gain. The unit shall be checked as follows:

- a. Pin 11 shall be connected to 28V dc, and a 150-ohm fixed carbon resistor shall be connected across pins 9 and 12.
- b. An audio oscillator operating at 1 kHz shall be connected to a system simulator and the voltage between pins 6 and 2 set to 0.05V rms (-24 dBm).
- c. The voltage at pins 9 and 12 (0.26V rms, ± 3 dB; -9.5 dBm, ± 3 dB) shall be measured.
- d. Without changing the voltage level output of the oscillator, repeat step c at output frequencies of 400 Hz and 3,000 Hz from the oscillator.

MIL-DTL-38449D

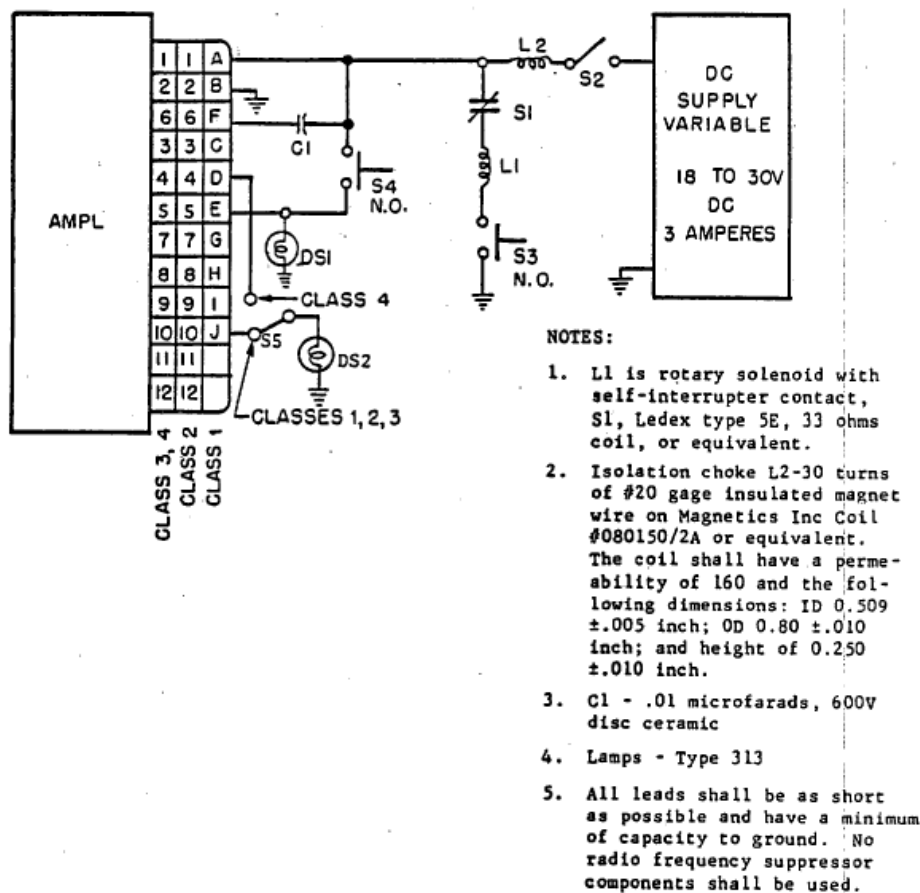
FIGURE 5. High frequency noise susceptibility test schematic.

4.4.6.3.3 Intercom loading. The output of an oscillator (600-ohm source impedance) shall be adjusted for an open-circuit voltage of 0.7V rms (0 dBm). Terminated with the intercom (pins 9 and 12), output shall change by no more than 1 dB.

4.4.6.3.4 Push-to-talk function (class 4 only). With SW15 in the class 4 position, move SW14 to the (REC), (OFF), and (TRANS) positions. In each position confirm proper operation of the audio section.

4.4.7 Environmental tests.

4.4.7.1 High temperature. This test shall be conducted in accordance with MIL-STD-810, Method 501.1, procedure I except that, at the conclusion of the functional test at 71°C and with the unit non-operating, the internal temperature of the chamber shall be raised from 71°C to 130°C and stabilized at 130°C. Upon conclusion of the 15-minute period, the temperature shall be returned to room temperature and the unit shall be functionally tested in accordance with

MIL-DTL-38449D

4.4.3. The unit shall then be temperature cycled for a 24-cycle period, each cycle consisting of the following:

a. The unit shall be placed in the chamber which has previously been stabilized at 130°C; the unit shall remain in the chamber at 130°C for 15 minutes (unit non-operating).

b. The unit shall be removed from the chamber and allowed to remain at room temperature for 15 minutes.

c. The functional test as specified in 4.4.3 shall be performed after 8, 16, and 24 temperature cycles.

4.4.7.2 Low temperature altitude. This test shall be conducted in accordance with MIL STD-810, Method 502.1, procedure I, except that the chamber pressure shall be reduced to that equivalent to 50,000 feet altitude during the last 21 hours of the test. The unit shall be functionally test as specified in 4.4.3. An altitude at 100,000 feet shall be demonstrated or adequately proven under non-operating conditions, the remaining 12 hours of the above 24 hour test may be substituted by a 100,000 foot-altitude equivalent pressure and conducting the functional test (4.4.3) upon returning pressure to sea level.

4.4.7.3 Fungus. The unit shall be tested in accordance with MIL-STD-810, Method 508.1. This test may be omitted if the parts and materials of the unit contain no nutrients for fungus growth.

4.4.7.4 Salt fog. The unit shall be tested in accordance with MIL-STD-810, Method 509.1.

4.4.7.5 Humidity. The unit shall be tested in accordance with MIL-STD-810, Method 507.1, procedure I.

4.4.7.6 Shock. The unit should be tested in accordance with MIL-STD-810, Method 516.2, procedure I using a terminal-peak-sawtooth pulse configuration with a peak value of 20g for a duration of 11 milliseconds. During the shock test, normally closed contacts shall be monitored for momentary opening; an opening time of 0.5 milliseconds or greater shall constitute failure of the unit.

4.4.7.7 Leakage (immersion). The unit shall be subjected to the leakage test in accordance with MIL-STD-810, Method 512.1, procedure I.

4.4.7.8 Vibration. The vibration test shall be performed in accordance with MIL-STD-810, Method 514.2, procedure I, curve D except that the 10g acceleration shall be extended to 1,000 Hz.

a. Each resonant and cycling period shall be divided into four equal parts; the first part being conducted at -54°C, the second part at room temperature, the third part at 71°C, and the fourth at -54°C (non-operating).

MIL-DTL-38449D

b. During the vibration, the unit shall be load cycled using a 3-ampere load and sequencing described in the life test (4.4.8) except at -54°C in the fourth part the unit shall be in a non-operating condition.

c. During vibration; the normally closed relay contacts shall be monitored for momentary opening. An opening time of 0.5 millisecond or greater shall constitute failure of the unit. The device used to detect opening of a closed contact for more than the specified time shall lock in an alarm condition. When a fault occurs, the alarm shall sound and shall not cease if the fault ceases. Manual reset shall be the only way to clear the alarm.

d. The test unit shall be functionally tested (4.4.3) at intervals of 500 load cycles. The number of load cycles shall be recorded and may apply toward the life test completion.

e. During the fourth part at -54°C, the vibration levels shall be as follows:

10-50 Hz	±0.050 inch DA (double-amplitude)
50-80 Hz	±6g
80-105 Hz	±0.018 inch DA
105-190 Hz	±10g
190-270 Hz	±0.0054 inch DA
270-2,000 Hz	±20g

4.4.8 Life. The unit shall be load cycled at room temperature connected in the test circuit of Figure 6 or a circuit approved by the qualifying activity. The unit shall be functionally tested as specified in 4.4.3 at intervals of 5,000 load cycles. The number of load cycles accumulated during vibration testing maybe added to the number of cycles required during life test, to total 50,000 cycles. One cycle shall consist of:

a. READY for 1 ±0.1 second. 28V dc shall be applied to pin A/1 and returned to pin B/2.

b. CONTACT for 1 ±0.1 second. Unit shall be placed in CONTACT by applying a 28V dc to 30V dc, 3- to 15-millisecond pulse to pin F/6.

c. DISCONNECT for 1 ±0.1 second. The unit shall be placed in DISCONNECT by applying a second 28V dc to 30V dc, 3- to 15-millisecond pulse to pin F/6.

d. OFF for 1 ±0.1 second. Power shall be removed from pin A/1.

e. In addition for classes 3 and 4 amplifiers only, an oscillator (set to -1 dBm, 1 kHz) shall be connected to pins 9 and 12; output pins 6 and 2 shall be terminated with 2.4K-ohm load.

4.4.9 Radio frequency interference. The amplifier shall be subjected to the following tests in accordance with MIL-STD-461. Noise resulting from actuation of the relay contacts shall be excluded from the measurements.

MIL-DTL-38449D

- Conducted interference (30 Hz to 14 kHz)
- Conducted interference (14 kHz to 100 MHz)
- Radiated interference (14 kHz to 400 MHz)
- Conducted susceptibility (30 Hz to 150 kHz)
- Conducted susceptibility (150 kHz to 400 MHz)

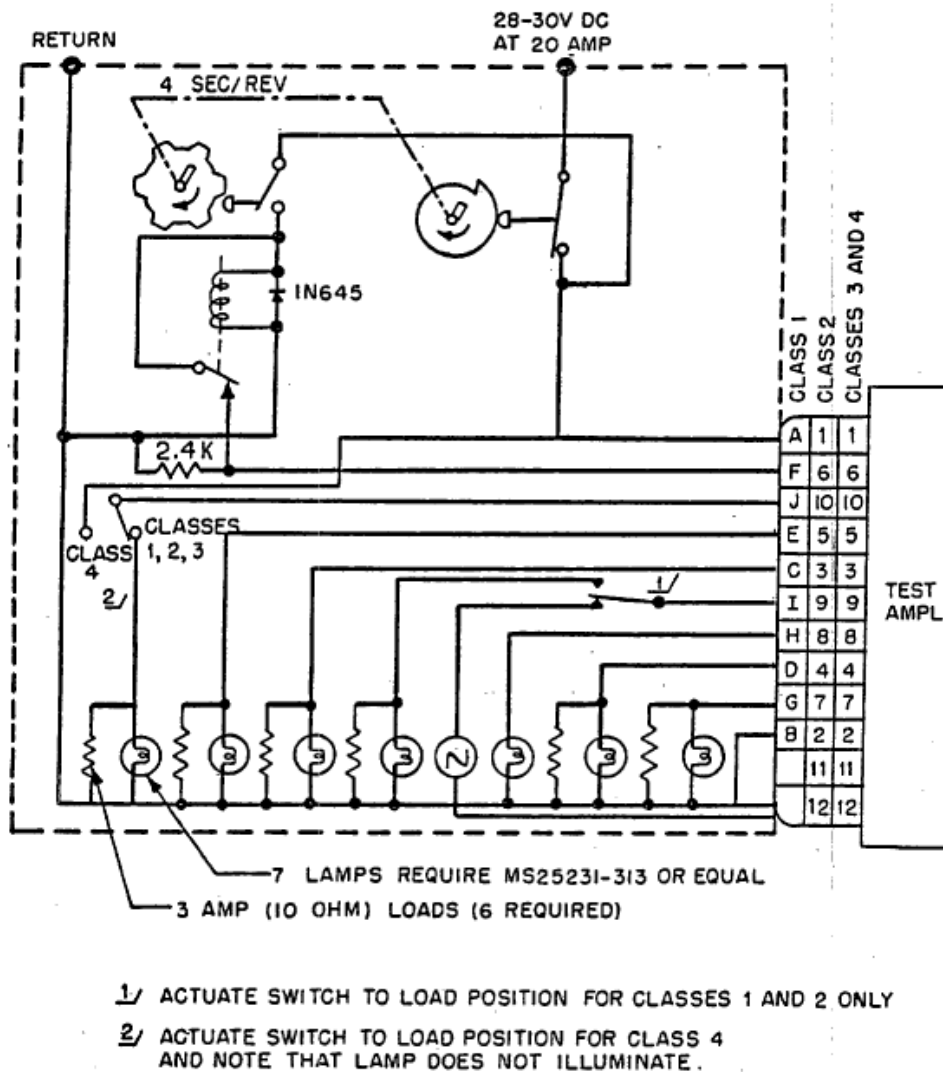

FIGURE 6. Life test schematic.

MIL-DTL-38449D

- f. Spike susceptibility 1/
- g. Radiated susceptibility (14 kHz to 10 GHz) 1/
- h. Radiated susceptibility, induction field.

1/ Spike susceptibility and radiated susceptibility may be omitted provided adequate proof of more severe tests can be shown or adequate proof that the amplifier is not affected by the tests.

4.5 Flight test. Ground or flight tests may be conducted by the qualifying activity to demonstrate compatibility of the unit with the aircraft system it is being incorporated into and the associated tanker or receiver aircraft as applicable. A minimum of 25 hookups shall be required for any combination of aircraft or amplifiers. A malfunction of the test unit shall be considered a failure.

4.5.1 Reliability. Satisfactory compliance with all tests specified herein and a Table citing failure rate data calculations for all components of the amplifier, stating quantity, stress level failure rate, and total parts failures resulting in an MTBF of 34,000 hours or greater (25,000 hours or greater for the intercom section of the classes 3 and 4 amplifiers) will demonstrate satisfactory reliability. Failure rate data will be obtained as specified in 3.5.2.1.

5. PACKAGING

5.1 Packaging. For acquisition purposes, the packaging requirements shall be as specified in the contract or order (see 6.2). When packaging of materiel is to be performed by DoD or in-house contractor personnel, these personnel need to contact the responsible packaging activity to ascertain packaging requirements. Packaging requirements are maintained by the Inventory Control Point's packaging activities within the Military Service or Defense Agency, or within the military service's system commands. Packaging data retrieval is available from the managing Military Department's or Defense Agency's automated packaging files, CD-ROM products, or by contacting the responsible packaging activity.

6. NOTES

(This section contains information of a general or explanatory nature that may be helpful, but is not mandatory.)

6.1 Intended use. The signal and signal intercommunication amplifiers covered by this specification will be used in receiver and tanker aircraft employing aerial refueling boom or receptacle equipment and in the ground support equipment necessary for these applications. Care should be taken to insure the use of the proper class of unit in a given installation.

6.1.1 Installation instructions (general). The following are general installation instructions:

- a. Mounting interface

MIL-DTL-38449D

(1) To replace a D7A/B signal amplifier with an M38449-1, -2, -3, or -4, remove the D7A/B and drill three holes in the electrical connector end of the mount base (MT70) in accordance with Figure 1 herein and the applicable technical orders. The electrical connectors of the M38449-1, -2, -3, or -4 should be oriented in the same direction as the D7A/B connector and should be centered on the base within 0.75 inch from the connector end of the base.

(2) To replace an A20-1A/B signal amplifier with an M38449-1, -2, -3, or -4 remove the A20-1A/B and mount tray (base) and install the replacement signal amplifier using the same three mounting holes and screws.

NOTE: The M38449-1, -2, -3, and -4 amplifiers are directly interchangeable with the exception of the electrical connector (see b.(2) below).

b. Electrical connector interface

(1) D7A/B and A20-1A/B signal amplifiers are directly interchangeable with the M38449-1.

(2) Replacing D7A/B and A20-1A/B signal amplifiers with M38449-2, -3 or -4 units requires changing the aircraft connector plug to a M83723-75R1212N, or using an adapter supplied with the signal amplifier.

c. Air vehicle intercom interface (For Information Only)

(1) Replacing D7A/B, A20-1A/B, M38449-1, or M38449-2 signal amplifiers with an M38449-3 or -4 unit requires connecting pin 9 to the audio portion of the aircraft intercom system and, when the aircraft is so equipped, pin 12 to audio common. Pin 11 should be connected to 28V dc for tanker-receiver intercom operation when the signal amplifier override mode of operation is used. For aircraft not having an override mode, check the appropriate technical orders for termination of pin 11. CAUTION: Once an M38449-3 or -4 signal amplifier has been installed, it must not be replaced with an M38449-1 or -2- without disconnecting pin 9. If this is not done, 28V dc will be applied to the aircraft intercom system since this is a normal output from pin I/9 of M38449-1 and -2 signal amplifiers during the contact and disconnect modes. In addition, pin 10 on class 4 units provide a push-to-talk feature. This pin should be connected to the push-to-talk microphone switch directly for push-to-talk operation only, or through a diode for both push-to-talk and voice operated switching operation. This information does not constitute authorization to perform a modification to an aircraft. Authorization should be made only by technical orders or contract directive.

NOTE: All diodes contained in the aerial refueling signal circuitry external to the signal amplifier must be removed prior to M38449-3 and -4 installation since the M38449-3 and -4 amplifier is equipped with a special diode for voice communications. M38449-1 and -2 amplifiers also contain standard diodes and do not require external aircraft-mounted diodes to protect the signal circuitry.

MIL-DTL-38449D

6.2 Acquisition requirements. Acquisition documents must specify the following:

- a. Title, number, and date of this specification.
- b. Class required (see 1.2).
- c. Packaging requirements (see 5.1).
- d. Data requirements (DD 1423)
- e. Delivery requirements.

6.3 Qualification. With respect to products requiring qualification, awards will be made only for products which are at the time set for opening of bids qualified for inclusion in the applicable Qualified Products List, whether or not such products have actually been so listed by that date. The attention of the suppliers is called to this requirement, and manufacturers are urged to arrange to have the products that they propose to offer to the Federal Government tested for qualification in order that they may be eligible to be awarded contracts or orders for the products covered by this specification. The activity responsible for the Qualified Products List is the Oklahoma City Air Logistics Center/ENSDDA, 3001 Staff Drive, Tinker AFB, OK 73145 af71@tinker.af.mil and information pertaining to qualification of products may be obtained from that activity.

6.4 Definitions.

6.4.1 Contact. Contact is the second amplifier relay position. This position may also be referred to as “latched”, however, the word “latched” more accurately describes the tanker and receiver aerial refueling hardware in the mated and locked position.

6.4.2 D7A/B. This series of signal amplifiers were very early versions which perform the same function as the M38449 series of amplifiers but are very large volume and are equipped with vacuum tubes and telegraph relays. This amplifier is not equipped with signal circuitry diodes.

6.4.3 A20-1A/B. This series of signal amplifiers is a later version of the D7A/B with the same function, but a smaller envelope and is a hermetically sealed unit. The /B version is equipped with an internal diode to protect the unit from misfiring due to stray signal voltages.

6.5 Subject term (key word) listing.

Communications
Signal Amp
UARRSI

6.6 Changes from previous issue. Marginal notations are not used in this revision to identify changes with respect to the previous issue due to the extent of the changes.

MIL-DTL-38449D

Custodian:
Air Force – 71

Preparing activity:
Air Force – 71

Reviewing activity:
Air Force – 84
Air Force – 99
DLA – GS

(Project 1680-2010-003)

NOTE: The activities listed above were interested in this document as of the date of this document. Since organizations and responsibilities can change, you should verify the currency of the information above using the ASSIST Online database at <https://assist.daps.dla.mil>.