

INCH-POUND

MIL-DTL-3661D
 19 November 2013
 SUPERSEDING
 MIL-DTL-3661C
 10 JUNE 2003

DETAIL SPECIFICATION

LAMP HOLDERS, INDICATOR LIGHTS, INDICATOR LIGHT HOUSINGS, AND INDICATOR LIGHT LENSES, GENERAL SPECIFICATION FOR

This specification is approved for use by all Departments and Agencies of the Department of Defense.

1. SCOPE

1.1 Scope. This specification covers the general requirements for lampholders, indicator lights, indicator-light housings, and indicator-light lenses including display and integral lamp driver network types and associated hardware. For the purpose of this specification, an indicator-light housing is an indicator light without a lens (see [6.5](#)).

1.2 Classification.

1.2.1 Type designation of lampholders and indicator-light housings. The type designation of lampholders and indicator-light housings will be in the following form, and as specified (see [3.2](#) and [6.2](#)):

<u>LH79</u>	<u>/1</u>
Style	Type
(1.2.1.1)	(1.2.1.2)

1.2.1.1 Style. The style is identified by a two-letter symbol "LH" followed by a two digit number.

1.2.1.2 Type. The applicable types based on circuit or mechanical parameters are identified by one or more digit numbers. The numbers will follow and be separated from the style number by a slash mark.

Comments, suggestions, or questions on this document shall be addressed to Defense Logistics Agency - Aviation, ATTN: DLA-Aviation VEB, 8000 Jefferson Davis Highway, Richmond, VA 23297-5616 or e-mailed to stdznmgt@dla.mil. Since contact information can change, you may want to verify the currency of this address information using the ASSIST database at <https://assist.dla.mil/>.

MIL-DTL-3661D

1.2.2 Type designation of lenses. The type designation of lenses will be in the following form, and as specified (see [3.2](#) and [6.2](#)):

<u>LC23</u>	<u>B</u>	<u>D</u>	<u>3</u>
Style	Color	Transmittance	Lens material
(1.2.2.1)	(1.2.2.2)	(1.2.2.3)	(1.2.2.4)

1.2.2.1 Style. The style is identified by a two-letter symbol "LC" followed by a two digit number.

1.2.2.2 Color. The color of the lens will be identified by a single letter in accordance with table I (see [3.4.9.2](#)).

TABLE I. Color.

Symbol	Color
B ¹	Blue
C	Colorless (clear) (D and N transmittance only).
G ¹	Green (identification).
R	Red (identification).
E	Red (aviation).
W	White (aviation) (T transmittance only).
Y	Yellow (aviation).
D	Black (opaque).
S	Gray (opaque).

¹Not recommended for used with neon lamps.

1.2.2.3 Transmittance. The lens transmittance will be identified by a single letter in accordance with table II.

TABLE II. Transmittance.

Symbol	Transmittance
D ¹	Diffusing ²
N	Nondiffusing
T ¹	Translucent ³
O ¹	Opaque ⁴
B ¹	Translucent/black overlay ⁵

¹Not recommended for used with neon lamps.

²In these lenses diffusion will be accomplished only by the surface closest to the lamp.

³In these lenses the diffusing media will be dispersed throughout the transmitting plastic material.

⁴In these lenses no light will be transmitted or reflected.

⁵Lens, prior to black overlay, will be translucent. Exterior viewing portion of the lens excluding any legend(s) will be covered with a black lusterless finish.

MIL-DTL-3661D

1.2.2.4 Material. The lens material will be identified by a one-digit number in accordance with table III (see [3.2](#)).

TABLE III. Lens Material.

Symbol	Material
2	Plastic (-55°C. to +71°C.)
3	Plastic (-55°C. to +125°C.)

1.2.3 Type designation of indicator lights (non-replaceable lens type). The type designation for indicator lights with non-removable lens and nomenclature display types will be in the following form and as specified (see [3.2](#) and [6.2](#)):

<u>LHC82</u>	<u>/1</u>	<u>BT2</u>
Style (1.2.3.1)	Type (1.2.1.2)	(1.2.2.2 To 1.2.2.4)

1.2.3.1 Style. The style is identified by a three-letter symbol “LHC” followed by a two-digit number.

2. APPLICABLE DOCUMENTS

2.1 General. The documents listed in this section are specified in sections 3 and 4 of this specification. This section does not include documents in other sections of this specification or recommended for additional information or as examples. While every effort has been made to ensure the completeness of this list, document users are cautioned that they must meet all specified requirements documents cited in sections 3 and 4 of this specification, whether or not they are listed.

2.2 Government documents.

2.2.1 Specifications, standards and handbooks. The following specifications, standards and handbooks form a part of this document to the extent specified herein. Unless otherwise specified, the issues of these documents are those listed in the issue of the Department of Defense Index of Specifications and Standards (DODISS) and supplement thereto, cited in the solicitation (see [6.2](#)).

INTERNATIONAL ORGANIZATION FOR STANDARDIZATION (ISO)

ISO10012 – Measurement management systems –
Requirements for measurement processes and measuring Equipment – First
Edition

AENOR UNE-EN ISO/IEC 17025 – Conformity assessment. General requirements for the
competence of testing and calibration laboratories

(Copy of this document is available from www.iso.org or the International Organization for Standardization American National Standards Institute, 11 West 42nd Street, 13th Floor, New York, NY 10036, United States.)

FEDERAL STANDARDS

FED-STD-3 - Colors, Aeronautical Lighting
FED-STD-595/36231 – Gray, Flat or Lusterless
FED-STD-595/37038 – Black, Flat or Lusterless

(Copies of these documents are available online at <http://quicksearch.dla.mil/>)

COMMERCIAL ITEM DESCRIPTION

MIL-DTL-3661D

A-A-59588 – Rubber, Silicone

DEPARTMENT OF DEFENSE SPECIFICATION

MIL-DTL-5541 – Chemical Conversion Coatings on Aluminum and Aluminum Alloys

MIL-A-8625 - Anodic Coatings for Aluminum and Aluminum Alloys
MS18235 - Lamp, Cartridge, Short Cylindrical, Plug-In, Incandescent,
Plastic (Flat Lens Type)
MS18236 - Lamp, Cartridge, Stovepipe, Plug In, Neon, Plastic (Curved
Lens Type)
MS18237 - Lamp, Cartridge, Long Cylindrical, Plug-In, Neon, Plastic
(Flat Lens Type)
MS18238 - Lamp, Cartridge, Short Cylindrical, Plug-In, Incandescent,
Glass (Flat Type)

DEPARTMENT OF DEFENSE STANDARDS

MIL-STD-108 - Definitions of and Basic Requirements for Enclosures for
Electric and Electronic Equipment
MIL-STD-130 - Identification Marking of U.S. Military Property
MIL-STD-202 – Test Method Standard Electronic and Electrical Component Parts
MIL-STD-1285 - Marking of Electrical and Electronic Parts
MIL-STD-1916 - DoD Preferred Methods for Acceptance of Product

(Copies of these documents are available online at <http://quicksearch.dla.mil/>)

2.3 Non-Government publications. The following document forms a part of this specification to the extent specified herein. Unless otherwise specified, the issues of the documents which are DoD adopted are those listed in the issue of the DODISS specified in the solicitation. Unless otherwise specified, the issues of documents not listed in the DODISS are the issues of the documents cited in the solicitation or contract. (see [6.2](#)).

AMERICAN SOCIETY FOR TESTING AND MATERIALS (ASTM)

ASTM B121/B121M - Standard Specification for Leaded Brass Plate, Sheet, Strip, and Rolled Bar
ASTM D635 - Standard Test Method for Rate of Burning and /or Extent and Time of Burning of
Plastics in a Horizontal Position
ASTM D4066 - Standard Classification System for Nylon Injection and Extrusion Materials (PA)

(Copies of these documents are available from www.astm.org or the American Society for Testing and Materials, 100 Barr Harbor Drive, W. Conshohocken, PA 19428-2959.)

SOCIETY OF AUTOMOTIVE ENGINEERS (SAE)

SAE-AS18012 - Markings for Aircrew Station Displays, Design and Configuration of

SAE-AS25050 - Colors, Aeronautical Lights and Lighting Equipment, General Requirements For

(Application for copies should be addressed to the Society of Automotive Engineers, Inc., 400 Commonwealth Drive, Warrendale, PA 15096-0001.)

2.4 Order of precedence. Unless otherwise noted herein or in the contract, in the event of a conflict between the text of this document and the references cited herein (except for related specification sheets), the text of

MIL-DTL-3661D

this document takes precedence. Nothing in this document, however, supersedes applicable laws and regulations unless a specific exemption has been obtained.

3. REQUIREMENTS

3.1 First Article. When specified (see [6.2](#)), a sample shall be subjected to first article inspection in accordance with [4.3](#).

3.2 Specification sheets. The individual lampholders, indicator lights, indicator-light housings and lens requirements shall be as specified herein and in accordance with the applicable specification sheets. In the event of any conflict between the requirements of this specification and the applicable specification sheets, the latter shall govern.

3.3 Materials.

3.3.1 General Requirements. Materials used in the manufacture of lampholders, indicator lights, indicator-light housings and lenses, shall be as specified herein and in the applicable specification sheet. However, when a definite material is not specified, a material shall be used which will enable the aforementioned items to meet the performance requirements of this specification. Acceptance or approval of any constituent material shall not be construed as a guarantee of the acceptance of the finished product.

3.3.2 Recycled, recovered, environmentally preferable, or biobased materials. Recycled, recovered, environmentally preferable, or biobased materials should be used to the maximum extent possible, provided that the material meets or exceeds the operational and maintenance requirements, and promotes economically advantageous life cycle costs.

3.3.3 Metal and finishes.

3.3.3.1 Metals. All metal parts, other than current-carrying parts, shall be of a corrosion-resistant material or shall be suitably plated to resist corrosion.

MIL-DTL-3661D

3.3.3.2 Finishes.

3.3.3.2.1 Exterior. The exterior surfaces, designed to be exposed at the front of the panel after assembly, shall have a black lusterless finish.

3.3.3.2.2 Aluminum (only). Unless otherwise specified (see [3.2](#)), all external aluminum parts shall be anodized in accordance with MIL-A-8625 and all internal aluminum parts shall be chemically treated in accordance with MIL-DTL-5541.

3.3.4 Dissimilar metals. When dissimilar metals are used in intimate contact with each other, protection against electrolysis and corrosion shall be provided. The use of dissimilar metals in contact, which tend toward active electrolytic corrosion (particularly brass, copper, or steel used in contact with aluminum or aluminum alloy), is not acceptable. However, metal plating or metal spraying of dissimilar base metals to provide similar or suitable abutting surfaces is permitted. The use of dissimilar metals separated by a suitable insulating material is also permitted. Dissimilar metals are defined in [6.3](#).

3.3.5 Plastic material (not applicable for lenses). Cotton base laminations, cotton, or cellulose-filled molding material shall not be used.

3.3.5.1 Thermoplastics. Unless otherwise specified (see [3.2](#)), thermoplastics shall not be used for fabricating indicator light housings and lampholder bases. When used for internal insulation the thermoplastic material shall be in accordance with Group 02 of ASTM D4066, or shall be of a high temperature polycarbonate material which is self-extinguishing when tested in accordance with ASTM D635.

3.3.6 Silicone rubber. Silicone rubber shall be in accordance with A-A-59588 when used as an "O" ring for external sealing devices.

3.4 Design and construction. Lampholders, indicator lights, indicator-light housings and lenses shall be so constructed as to insure proper operation when mounted in any position and shall conform to the design, construction, and physical dimensions as specified (see [3.2](#)).

3.4.1 Mounting hardware. All mounting hardware shall be as specified (see [3.2](#)) and need not be assembled when being furnished for inclusion in production equipment. For direct Government procurement, all mounting hardware shall be assembled to the lampholder in the order specified (see [3.2](#)) or, shall be included in the unit package with the lampholder.

3.4.2 Terminals. The terminal design shall be as specified (see [3.2](#)).

3.4.2.1 Solder terminals (when applicable). Solder terminals shall be designed to accept two wire leads, AWG #20, per terminal unless otherwise specified (see [3.2](#)) and shall be treated to facilitate soldering.

3.4.2.2 Screw terminals (when applicable). Screw terminals shall be provided with hardware, as specified (see [3.2](#)).

3.4.2.3 Terminal identification. Lampholders, indicator lights and indicator-light housings, designed to accommodate neon lamps, shall be marked with a plus (+) sign at the terminal which is electrically connected to the center contact of the lamp used.

MIL-DTL-3661D

3.4.3 Screw threads. Screw threads on externally threaded parts, or parts subject to replacement or removal, shall be in accordance with Handbook H28. Threading of non-metallic parts will not be permitted unless otherwise specified on the specification sheet (see [3.2](#)).

3.4.4 Anti-rotational means. Lampholders, indicator lights and indicator-light housings shall be designed with an anti-rotational mounting means.

3.4.5 Panel accommodation. Unless otherwise specified (see [3.2](#)), indicator lights and indicator-light housings shall be designed to accommodate panels up to .187-inch in thickness using applicable mounting hardware furnished. Mounting flanges shall be of the fixed type.

3.4.6 Current-limiting resistors. Current-limiting resistors used for neon indicator lights and housings shall have a tolerance not to exceed ± 20 percent and the applicable ohmic value shall be as specified (see [3.2](#)). The resistor shall be physically located internally to the indicator light or indicator-light housing.

3.4.7 Press-to-test operation. When specified (see [3.2](#)), the light shall be such that the lamp may be tested by pressing on the lens of the assembly. When the pressure is released, the test circuit to the lamp shall be opened and the lens assembly shall return to its normal position.

3.4.8 Lamp circuitry. Lampholders, indicator lights, and indicator-light housings shall be designed with an electrically isolated lamp circuit.

3.4.8.1 Lamp accommodation (not applicable to non-removable lens assemblies). Panel mounted indicator lights and indicator-light housings shall be designed so that the lamp(s) can be replaced from the front of the panel. No tools of any type shall be required to replace the lamp (s).

3.4.8.2 Plug-in cartridge type lamps. Indicator-light housings using cylindrical plug-in lamps shall be designed to accommodate lamps in accordance with MS18235, MS18236, MS18237 and MS18238. Current limiting resistors required for neon lamps shall be built into the lamp cartridges.

3.4.9 Lenses.

3.4.9.1 Lens fabrication. The lens viewing area (window) shall be secured to a threaded metal bushing, as applicable (see [3.2](#)).

3.4.9.2 Color. The lens color shall be in accordance with FED-STD-3 or SAE-AS25050, unless otherwise specified (see [3.2](#)), and as follows:

3.4.9.2.1 Symbol C (colorless). Colorless is defined as a lens which does not change the color coordinates (± 0.1) of the calibrating lamp when measured from the front of the lens.

3.4.9.2.2 Symbol B (blue). The blue color shall be within the boundary formed by the interconnection of the points shown for the chromaticity coordinates.

Point	X - Axis	Y - Axis
1	.065	.220
2	.082	.268
3	.154	.220
4	.165	.270

3.4.9.2.3 Symbol W (white), symbol Y (yellow), symbol E (red aviation). White, yellow and red aviation colors shall be in accordance with category I (aviation colors).

3.4.9.2.4 Symbol G (green), symbol R (red). Green and red colors shall be in accordance with category II (identification colors).

MIL-DTL-3661D

3.4.9.2.5 Symbol S (gray). Gray color shall be in accordance with FED-STD-595, number 36231.

3.4.9.2.6 Symbol D (black). Black color shall be in accordance with FED-STD-595, number 37038.

3.4.9.3 Mounting. Lenses shall be so designed that when they are repeatedly removed and installed to their applicable mating holder (that is indicator-light housing etc.) that no physical contact will be imposed on the lamp envelope.

3.4.9.4 Lamp retention. Lenses, designed to accommodate midget flange base lamps, shall include a lamp retainer means.

3.4.9.5 Marking. When specified (see 6.2), symbols and legend to be displayed on lenses shall conform to SAE-AS18012. Corners and ends of character strokes may exhibit radii.

3.4.10 Lamp contacts.

3.4.10.1 Contact and spring material. Lamp contacts shall be of a copper base alloy and shall be suitably plated. Lamp contact springs shall be beryllium copper suitably plated or shall be of a corrosion-resistant steel. When the contact and contact spring are combined as an integral part (one piece of metal) copper beryllium alloy or phosphor bronze, suitably plated, shall be used.

3.4.10.1.1 Moving contacts (bayonet locking holders). The distance between the top of the moving contacts and the top of the locking slot shall be .047 inch minimum, .156-inch maximum for miniature lamp sockets, and .187 inch minimum, .234 inch maximum for candelabra lamp sockets (see [figure 1](#)).

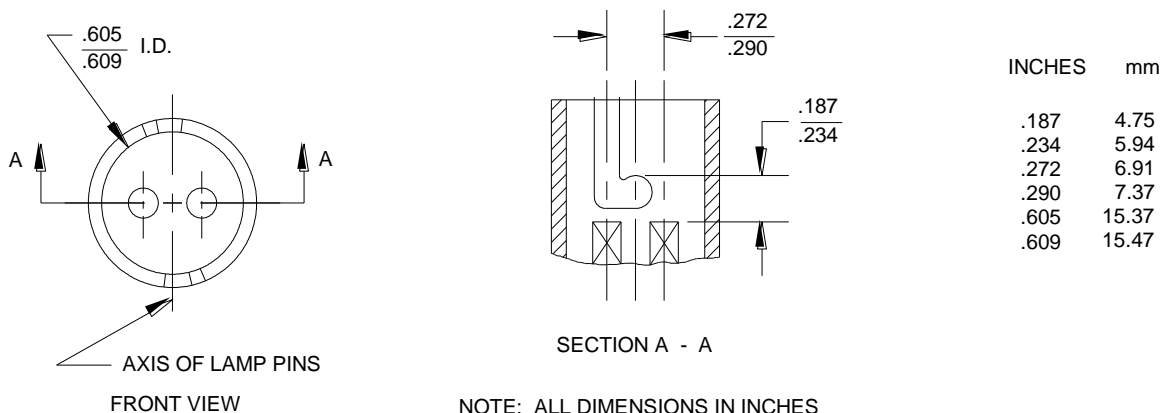

NOTE: ALL DIMENSIONS IN INCHES
 CANDELABRA BAYONET LAMP SOCKETS

FIGURE 1. Moving contacts.

MIL-DTL-3661D

3.4.11 Electromagnetic interference (see 3.2). When required, lens designed for electromagnetic interference capability shall include an integral metal mesh. An electrical continuity shall exist between lens and housing.

3.5 Performance.

3.5.1 Dielectric withstanding voltage. Lampholders, indicator lights, and indicator-light housings shall withstand the voltage specified in [4.6.2](#) without arcing, flashover, or current flow in excess of 1 milliamper. The item shall be electrically operative after the test.

3.5.2 Terminal strength. When lampholders, indicator lights, and indicator-light housings are tested as specified in [4.6.3](#), there shall be no mechanical or electrical damage.

3.5.3 Solderability. Lampholders, indicator lights, and indicator-light housings shall be tested in accordance with [4.6.4](#). The soldered area shall show at least 95 percent coverage after the application of the dip-coated process.

3.5.4 Temperature cycling. When lampholders, indicator lights, indicator-light housings and lenses are tested as specified in [4.6.5](#), there shall be no mechanical or electrical damage, as applicable. The lens shall show no visual color degradation after the test.

3.5.5 Sand and dust. When specified (see [3.2](#)), indicator lights shall be tested as specified in [4.6.6](#), there shall be no evidence of any dust inside the lamp assembly. The item shall be electrically operative after the test. The press-to-test unit shall be mechanically and electrically operative.

3.5.6 Circuit continuity. When indicator lights are tested as specified in [4.6.7](#), the indicator light continuity shall conform to the applicable circuitry (see [3.2](#)).

3.5.7 Contact resistance (not applicable to non-removable lens type indicator lights, or to lamp housings with integral resistor).

3.5.7.1 Moving type contact. The contact resistance of lampholders, indicator lights and indicator-light housings, employing spring-loaded contact assemblies, shall not be more than 1 ohm when tested as specified in [4.6.8](#) and [4.6.8.1](#).

3.5.7.2 Static type contacts (for cylindrical plug-in lamps). The contact resistance of static type lampholders, indicator lights, and indicator-light housings shall not be more than 50 milliohms when tested as specified in [4.6.8](#) and [4.6.8.2](#).

3.5.8 Contact spring pressure (not applicable for non-removable lens type indicator lights). The contact spring pressure for the following type lamps shall be within the specified range for the applicable type lamp socket when tested as specified in [4.6.9](#).

- (a) Single contact T-3-1/4, lamps, 24-72 ounces.
- (b) Double contact candelabra bayonet base lamps, 48-144 ounces.
- (c) Midget flange base lamps, 12-36 ounces.
- (d) Submidget flange base lamps, 6-9 ounces.

MIL-DTL-3661D

3.5.9 Torque.

3.5.9.1 Socket shell torques (applicable only to lampholders and indicator-light housings that are designed to accept bayonet base lamps). When lampholders and indicator-light housings are tested as specified in [4.6.10.1](#), the socket shell shall withstand the applied torque with no resultant permanent damage.

3.5.9.2 Lens torque. The lens when tested as specified in [4.6.10.2](#), shall withstand the specified torque without any mechanical damage to the lens assembly or mating holder.

3.5.9.3 Busing torque. Indicator-lights and indicator-light torque housings, that are bushing mounted, shall withstand the specified torque when tested in accordance with [4.6.10.3](#), without any mechanical or electrical damage.

3.5.9.4 Dimmer torque. Lenses, incorporating dimmer designs, shall withstand the specified torque when tested in accordance with [4.6.10.4](#). No mechanical damage shall occur.

3.5.10 Sealing. When specified (see [3.2](#)), indicator lights shall be tested as specified in [4.6.11](#). There shall be no evidence of water leakage around the test enclosure opening.

3.5.11 Salt spray (corrosion). When lampholders, indicator lights, indicator-light housings and lenses are tested as specified in [4.6.12](#), there shall be no evidence of excessive corrosion. Excessive corrosion is defined as that which interferes with the electrical or mechanical performance, or in the case of plated metals, corrosion which has passed through the plating and attacked the base metal. There shall be no warping, cracking, or other damage and the lenses shall show no color degradation.

3.5.12 Life.

3.5.12.1 Electrical. When lampholders and indicator lights are tested as specified in [4.6.13](#) and [4.6.14](#), there shall be no light intermittency noted during the test and the applicable lens shall have an even color distribution over the viewing area after the test.

3.5.12.2 Mechanical (applicable to dimmer type indicator lights). The light dimmer cover shall be capable of operation from extreme dim to extreme bright positions, without failure as specified in [4.6.15](#).

3.5.13 Vibration. When lampholders, indicator lights, indicator-light housings and lenses are tested as specified in [4.6.16](#), the contact-spring pressure shall be as specified in [3.5.8](#), and there shall be no chipping, cracking, or crazing of materials, or loosening, bending, warping, or distortion of parts, and the orientation of rotatable indicator-light lenses shall not change.

3.5.14 Shock. When lampholders, indicator lights, indicator-light housings and lenses are tested as specified in [4.6.17](#), the contact-spring pressure shall be as specified in [3.5.8](#), and there shall be no chipping, cracking, or crazing of materials, or loosening, bending, warping, or distortion of parts.

3.5.15 Moisture resistance. When lampholders, indicator lights, indicator-light housings and lenses are tested as specified in [4.6.18](#), the insulation resistance shall be not less than 25 megohms, and the dielectric withstanding voltage shall be as specified in [3.5.1](#). There shall be no corrosion, the black finish (see [3.3.3.2.2.1](#)) shall not be removed, and there shall be no decomposition, leaching out, or spreading of constituent materials, or other defect detrimental to the intended function of the lampholder, indicator light, indicator-light housing or lens, and no loss of color or discoloration.

3.5.16 Luminance. Indicator lights shall be tested in accordance with [4.6.19](#) and the brightness level shall be in accordance with [3.2](#), when specified.

MIL-DTL-3661D

3.6 Marking. Marking shall be in accordance with MIL-STD-130. Marking shall include the manufacturer's name or trademark, or code symbol (in addition, electronically controlled devices shall include date code) in accordance with MIL-STD-1285 and the following:

3.6.1 Lampholders and indicator – light housings. Unless otherwise specified in the contract or order, the lampholders and indicator-light housings shall be marked with the type designation (see [3.2](#)).

3.6.2 Indicator lights. For indicator lights that have a non-removable lens design, the complete type designation shall be marked on the indicator light body unless otherwise specified (see [3.2](#)).

3.6.3 Lens. The type designation for lenses (see [3.2](#)) shall be marked on the unit package.

3.7 Workmanship. Lampholders, indicator lights, indicator-light housings and lenses shall be free from defects that will affect life, serviceability, or appearance and the following:

(a) Indicator-light housings.

- (1) No sharp edges shall be noticed on threaded and body parts.
- (2) Terminals shall not be bent out of regular designed position.
- (3) No solder splattering shall be noticed in the socket cavity or around the terminal header design.

(b) Lenses.

- (1) No visual crazing or color degradation shall be noted.
- (2) When illuminated under diffused light source, color dispersement shall be uniform.

4. VERIFICATION

4.1 Classification of inspections. The inspection requirements specified herein are classified as follows:

- a. First Article Inspection (see [4.4](#)).
- b. Conformance inspection (see [4.5](#)).

4.2 Component and materials inspection. In accordance with 4.1, components and materials shall be inspected in accordance with all the requirements of referenced documents, unless otherwise excluded, amended, modified, or qualified in this specification or applicable document.

4.3 Inspection conditions. Unless otherwise specified (see [3.2](#)), all inspection shall be conducted at the ambient temperature, pressure, and humidity conditions specified in the “General Requirements” of MIL-STD-202.

4.3.1 Test equipment and inspection facilities. Test equipment and inspection facilities shall be of sufficient accuracy, quality, and quantity to permit performance of the required inspection. The supplier shall establish calibration of inspection equipment to the satisfaction of the Government. Calibration of standards which control the accuracy of the inspection equipment shall comply with the requirements of ISO 10012 or ISO/IEC 17025.

MIL-DTL-3661D

4.4 First Article Inspection. When specified (see [3.1](#) and [6.2 d](#)), it shall be tested for the characteristics specified in [table IV](#).

4.4.1 Samples for first article. All test units shall be tested with the lenses assembled to the units.

4.4.1.1 Single submission. Twelve sample lampholders, indicator lights, or basic indicator-light housings and at least one lens of each style, color, and transmittance shall be submitted for first article inspection. As many different lens styles, colors, and transmittances as possible should be tested with each basic indicator-light housing sample to give the broadest representative sample used with each indicator light.

4.4.1.2 Group submission (when applicable). Samples shall be submitted as specified (see [3.2](#)).

4.4.2 Test routine. All sample units shall be subjected to the inspection of group I, [table IV](#). The sample units shall then be divided as specified in [table IV](#) for groups II to [V](#) inclusive, and subjected to the group inspection for their particular group, in the order shown.

4.4.3 Failures.

4.4.3.1 Removable lens type failure. Failure in any of the applicable examinations or tests of [table IV](#) shall be cause for refusal. Lamp failure will not be cause for failure of any parts tested, provided the test at which failure of lamp is noted, is stopped immediately and a new lamp is installed and the lamp immediately lights. The test shall then be continued.

4.4.3.2 Non-removable lens type failure (excluding nomenclature display types). Failure in any of the examinations or tests of [table V](#), with the following exceptions, shall be cause for refusal¹:

- (a) [Table IV](#), group II, temperature cycling.
- (b) [Table IV](#), group III, vibration and shock.

¹ If one indicator fails any of the tests specified in 4.4.3.2(a) or (b), it may be replaced by 6 of the same type indicators and the testing in that group resumed. Any further failure shall be cause for refusal.

MIL-DTL-3661D

TABLE IV. First Article Tests.

Examination and tests	Requirement paragraph	Method paragraph
Group I (All 12 sample units) Visual and mechanical examination Contact resistance Luminance Circuit continuity	3.3 to 3.4.11 incl., 3.6 and 3.7 3.5.7 3.5.16 3.5.6	4.6.1 4.6.8.1 ¹ and 4.6.8.2 ¹ 4.6.19 ² 4.6.7
Group II (3 sample units from group I) Bushings torque Temperature cycling Solderability Sand and dust Terminal strength Lens torque Dimmer torque Socket shell torque Contact resistance Dielectric withstanding voltage	3.5.9.3 3.5.4 3.5.3 3.5.5 3.5.2 3.5.9.2 3.5.9.4 3.5.9.1 3.5.7 3.5.1	4.6.10.3 ¹ 4.6.5 4.6.4 4.6.6 ² 4.6.3 4.6.10.2 ¹ 4.6.10.4 ¹ 4.6.10.1 ¹ 4.6.8.1 ¹ and 4.6.8.2 ¹ 4.6.2.1 and 4.6.2.2 ²
Group III (3 sample units from group I) Bushings torque Terminal strength Vibration Shock (method I or II as specified) Contact resistance Dimmer torque Lens torque Dielectric withstanding voltage	3.5.9.3 3.5.2 3.5.13 3.5.14 3.5.7 3.5.9.4 3.5.9.2 3.5.1	4.6.10.3 ¹ 4.6.3 4.6.16 4.6.17 4.6.8.1 ¹ and 4.6.8.2 ¹ 4.6.10.4 ¹ 4.6.10.2 ¹ 4.6.2.1 and 4.6.2.2 ²
Group IV (3 sample units from group I) Contact spring pressure Life (mechanical) Life (electrical) Press-to-test operation Sealing Contact resistance Lens torque Dimmer torque Dielectric withstanding voltage Salt spray (corrosion)	3.5.8 3.5.12.2 3.5.12.1 3.5.12.1 3.5.10 3.5.7 3.5.9.2 3.5.9.4 3.5.1 3.5.11	4.6.9 ¹ 4.6.15 ¹ 4.6.13 4.6.14 ¹ 4.6.11 4.6.8.1 ¹ and 4.6.8.2 ¹ 4.6.10.2 ¹ 4.6.10.4 ¹ 4.6.2.1 and 4.6.2.2 ² 4.6.12
Group V (3 sample units from group I) Moisture resistance Sealing Dielectric withstanding voltage	3.5.15 3.5.10 3.5.1	4.6.18 4.6.11 ² 4.6.2.1 and 4.6.2.2 ²

¹ As applicable.² When specified (see [3.2](#)).

MIL-DTL-3661D

4.5 Conformance inspection. Conformance inspection shall consist of groups A and B, and group C inspection, as applicable, as specified in 4.5.1 through [4.5.4.1.1](#).

4.5.1 Inspection lot. An inspection lot, far as practicable as, shall consist of all lampholders, indicator-light housings, lenses, or indicator lights shown on the same specification sheet, produced under essentially the same conditions and offered for inspection at one time.

4.5.2 Group A inspection. Group A inspection shall consist of the examination and tests specified in Table V, in the order shown.

4.5.2.1 Sampling plan. Statistical sampling and inspection shall be in accordance with MIL-STD-1916 for ordinary inspection.

TABLE V. Group A inspection.

Examination and tests	Requirement paragraph	Method paragraph
Visual and mechanical examination	3.2 , 3.4 to 3.4.10.1.1 incl., 3.6 and 3.7	4.6.1
Contact resistance	3.5.7	4.6.8.1 ¹ and 4.6.8.2 ¹
Circuit continuity (Units with non-replaceable lenses)	3.5.6	4.6.7
Dielectric withstanding voltage	3.5.1	4.6.2.1 and 4.6.2.2 ²

¹ As applicable.

² When specified (see [3.2](#)).

4.5.3 Group B inspection. Group B inspection shall consist of a sealing test as required by [3.5.10](#) and performed in accordance with [4.6.11](#). This test shall be performed every six months, utilizing 12 samples chosen at random from a current lot of material. No failures shall be allowed for group B inspection.

4.5.3.1 Disposition of group B sample units. Sample units subjected to group B inspection may be delivered as a part of the lot under the contract or order.

4.5.4 Group C inspection. Group C inspection shall consist of the tests specified in table VI, in the order shown. The sampling shall be as specified in [4.5.4.1](#). No failures shall be allowed for group C inspection except for non-removable units as defined in [4.4.3.2](#). Shipment of lots will not be held up pending completion of group C inspection.

MIL-DTL-3661D

TABLE VI. Group C inspection.

Tests	Requirement paragraph	Method paragraph
Group 1 (3 sample units)		
Contact spring pressure	3.5.8	4.6.9 ¹
Temperature cycling	3.5.4	4.6.5
Solderability	3.5.3	4.6.4
Sand and dust	3.5.5	4.6.6 ²
Luminance	3.5.16	4.6.19
Terminal strength	3.5.2	4.6.3
Bushing torque	3.5.9.3	4.6.10.3 ¹
Vibration	3.5.13	4.6.16
Shock (method I or II, as specified)	3.5.14	4.6.17
Dielectric withstanding voltage	3.5.1	4.6.2.1 and 4.6.2.2 ²
Group II (3 sample units)		
Moisture resistance	3.5.15	4.6.18
Dielectric withstanding voltage	3.5.1	4.6.2.1 and 4.6.2.2 ²
Group III (3 sample units)		
Salt spray (corrosion)	3.5.11	4.6.12
Group IV (3 sample units)		
Life (mechanical)	3.5.12.2	4.6.15 ¹
Life (electrical)	3.5.12.1	4.6.13
Press-to-test operation	3.5.12.1	4.6.14 ¹
Contact resistance	3.5.7	4.6.8.1 ¹ and 4.6.8.2 ¹
Lens torque	3.5.9.2	4.6.10.2 ¹
Dimmer torque	3.5.9.4	4.6.10.4 ¹
Socket shell torque	3.5.9.1	4.6.10.1 ¹
Dielectric withstanding voltage	3.5.1	4.6.2.1 and 4.6.2.2 ²

¹ As applicable.² When specified (see [3.2](#)).

4.5.4.1 Sampling for group C inspection. Twelve sample units of lampholders, indicator lights, or indicator-light housings of each style and at least one lens of each style, color and transmittance shall be selected once a year or after 100,000 units have been produced whichever comes first. Thereafter, twelve sample units shall be selected after 100,000 lampholders and so forth of each style have been produced or after three years, whichever comes first.

4.5.4.1.1 Disposition of group C sample units. Sample units subjected to group C inspection shall not be delivered as part of the lot under the contract or order.

MIL-DTL-3661D

4.5.4.2 Noncompliance. If a sample fails to pass group C inspection, the manufacturer shall take corrective action on the process and on all units of product which can be corrected and which were manufactured with the same conditions, materials, and processes, and are considered subject to the same test failure. Conformance inspection shall be discontinued until corrective action has been taken. After the corrective action, sample units shall be subjected to the necessary group C inspection (all inspections, or the failed inspections, at the option of the Government). Groups A and B inspection may be reinstated; however, final acceptance shall be withheld until the group C inspection has shown that the corrective action was successful.

4.6 Methods of examination and test.

4.6.1 Visual and mechanical examination. Lampholders, indicator lights, indicator-light housings and lenses shall be examined to verify that the materials, design, construction, physical dimensions, marking, and workmanship are in accordance with the requirements of this specification and the applicable specification sheet.

4.6.2 Dielectric withstanding voltage (see 3.5.1). Lampholders, indicator lights and indicator-light housings shall be tested in accordance with 4.6.2.1, and when specified, in accordance with 4.6.2.2 (see 3.2).

4.6.2.1 At atmospheric pressure. Lampholders, indicator lights and indicator-light housings shall be tested in accordance with method 301 of MIL-STD-202. The following details shall apply:

- (a) Test voltage: 1,000 volts, unless otherwise specified (see 3.2).
- (b) Nature of potential: A.C.
- (c) Duration of application: One minute for qualification and group C inspection, 5 seconds for other tests.
- (d) Points of application (with specimen properly mounted on a metal panel with all associated hardware) :

- (1) Between all unground, terminals and ground (with dummy lamp) .¹
- (2) Between lamp circuit terminals (with no lamp) .²

4.6.2.2 At reduced barometric pressure. Lampholders, indicator lights and indicator-light housings, designed for operation above 10,000 feet shall be tested as specified in 4.6.2.1 and in accordance with method 105 of MIL-STD-202. The following details and exceptions shall apply:

- (a) Test voltage : 250 volts, unless otherwise specified (see 3.2).
- (b) Test-condition letter - - -C.

4.6.3 Terminal strength (see 3.5.2). Lampholders, indicator lights and indicator-light housings shall be tested in accordance with method 211 of MIL-STD-202 and 4.6.3.1 or 4.6.3.2, as applicable.

4.6.3.1 Solder and screw terminals. Lampholders, indicator lights and indicator-light housings shall be tested as follows:

- (a) Test-Condition letter:
 - (1) Solder terminals - A.
 - (2) Screw terminals - E.
- (b) Applied force: Solder: 2 pounds.

¹ Dummy lamp means no filament.

² For non-removable lens type design and electronically controlled indicator lights, the point of application shall be from each terminal to ground.

MIL-DTL-3661D

4.6.3.2 Wire - lead terminals. Indicator lights having permanently set wire-lead terminations shall be tested as specified in [4.6.3.1](#) with the following exception:

- (a) Test-condition letter - C.
- (b) Load: 2-1/2 pounds.

4.6.4 Solderability (see [3.5.3](#)). Lampholders, indicator lights and indicator-light housings shall be tested in accordance with method 208 of MIL-STD-202. The following detail shall apply:

- (a) Number of terminals to be tested:
Minimum of two terminals per unit.

4.6.5 Temperature cycling (see [3.5.4](#)). Lampholders, indicator lights and indicator-light housings mated with an applicable lens shall be subjected to the temperature cycling test in accordance with method 102 of MIL-STD-202. The following details and exceptions shall apply:

- (a) Test-condition letter-D.
 - (1) Steps 2 and 4 shall be omitted.
 - (2) Test conducted with lamp installed but not energized.
 - (3) Lenses shall be tested separately at the temperature specified (see [3.2](#)), if the lens temperature exceeds that of the applicable lampholder or indicator-light housing.
- (b) Measurement after test - with an appropriate lamp installed when applicable. The specimens shall be energized and observed for any visual electrical malfunction; that is, low light output or intermittency. The lens shall be observed for any visual color discrepancy ; that is, lack of color uniformity, hot spots, or faded coloring (washout).
- (c) Examination-After the test, lenses shall be examined for looseness of parts, chipping and cracking of material, discoloration, and other damage.

4.6.6 Sand and dust (see [3.5.5](#)). Indicator lights shall be tested in accordance with Method 110, test condition A, of MIL-STD-202 and as follows:

- (a) The indicator light shall be mounted on a rigid metal panel in such a way that the sand will not impinge directly on it.
- (b) During the test the indicator light shall not be energized.

4.6.7 Circuit continuity (see [3.5.6](#)). Indicator lights shall be tested to determine conformance of the actual circuit.

4.6.8 Contact resistance (see [3.5.7](#)). The contact resistance of the lamp electrical circuit shall be tested in accordance with method 307 of MIL-STD-202 as applicable (see [4.6.8.1](#) and [4.6.8.2](#)).

MIL-DTL-3661D

4.6.8.1 Moving type contacts (not applicable to non-removable lens designs or to lamp housings with integral resistor). The contact resistance of lampholders, indicator lights and indicator-light housings, accommodating T-1-submidget flange base lamps, and T-1-3/4 midget flange base lamps, T-3-1/4 bayonet base lamps and double contact candelabra base lamps, shall be tested in accordance with 4.6.8 and as follows:

- (a) Preparation for test - An applicable test plug (see figures 2, 3, and 4) shall be inserted into the lens or socket of lampholder or indicator-light housing. If plug (figure 2) is inserted into the lens, the lens shall then be tightened by hand in the indicator-light housing.
- (b) Method of connection - Between two lamp terminals.
- (c) Test current-0.1 ampere at 6 volts d.c. open circuit voltage.
- (d) Number of lamp insertions-3.
- (e) Number of measurements per insertion-one measurement. (The average of three readings shall be the contact resistance).

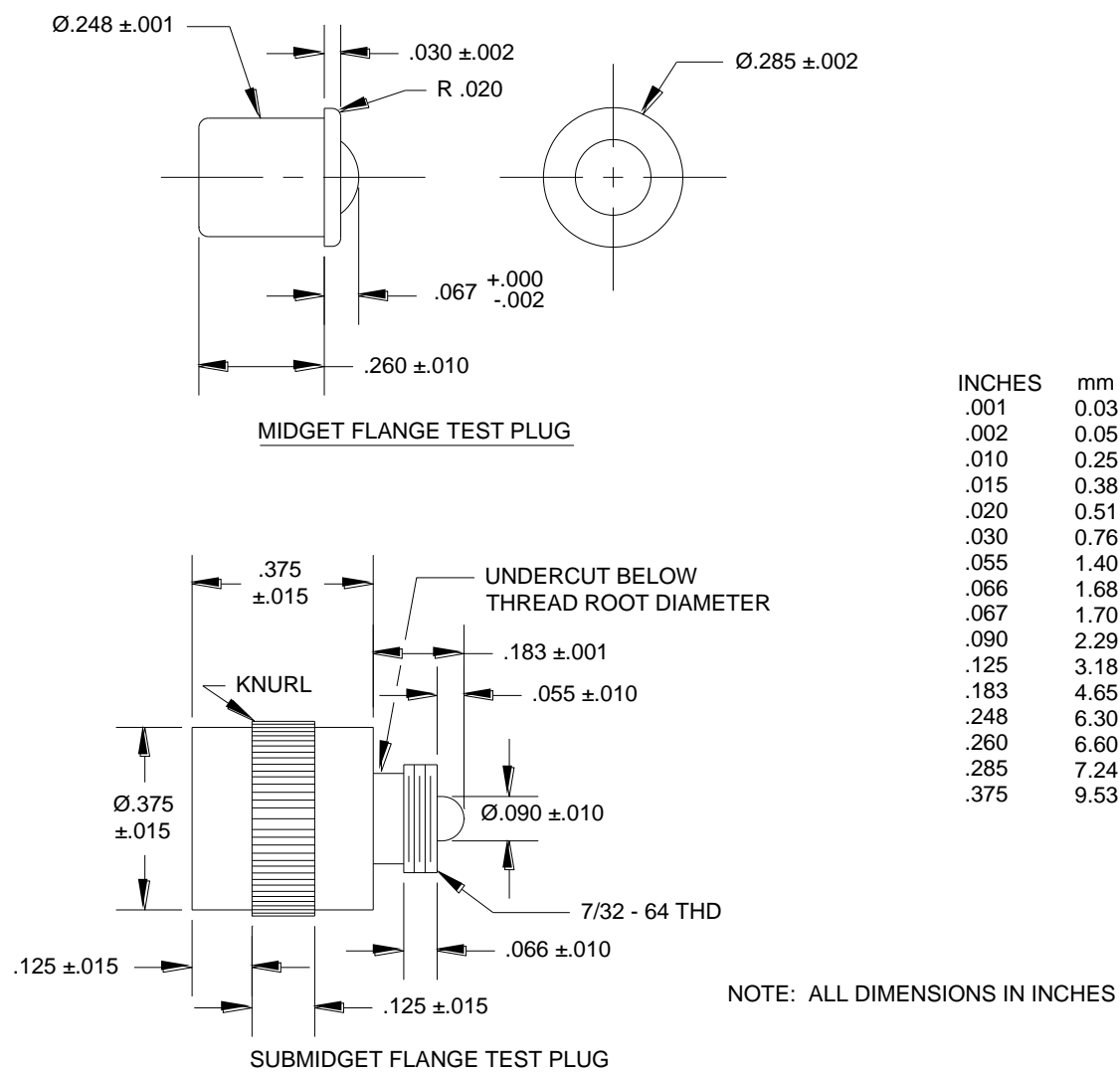

FIGURE 2. Midget and submidget flange base test plugs.

MIL-DTL-3661D

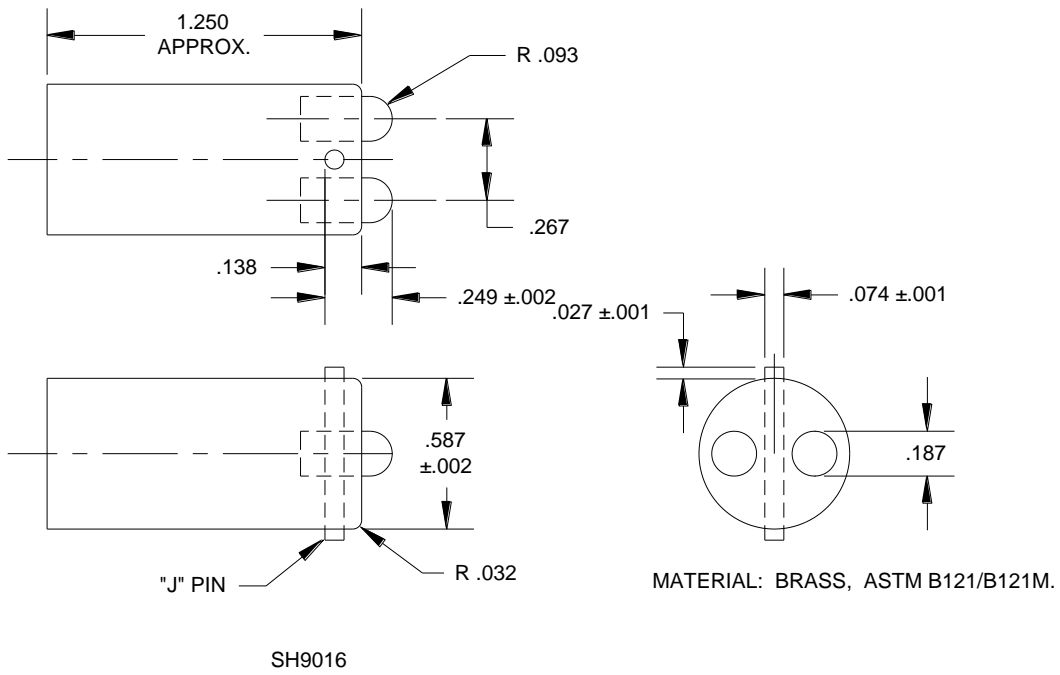

FIGURE 3. Double contact candelabra bayonet test plug.

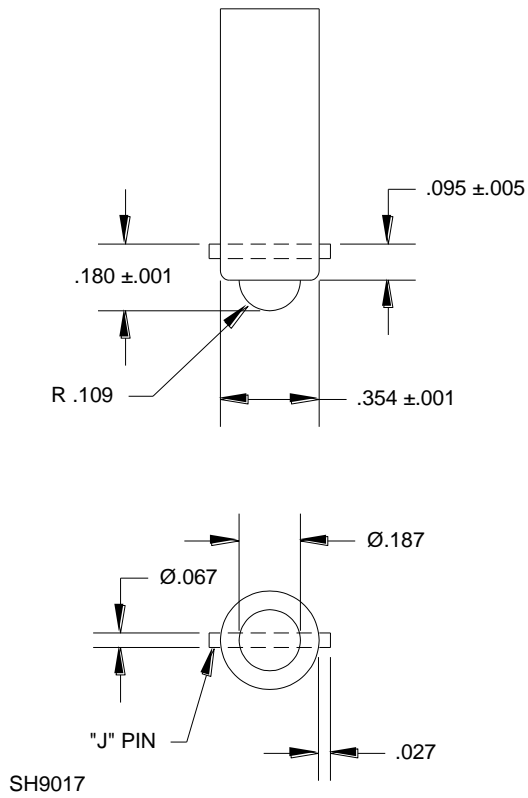

FIGURE 4. Miniature bayonet base test plug.

MIL-DTL-3661D

4.6.8.2 Static type contacts. The contact resistance of lampholders, indicator lights, and indicator-light housings accommodating cylindrical plug-in cartridge type lamps shall be tested in accordance with 4.6.8 and as follows:

- (a) Preparation for test—An applicable test plug (see [figure 5](#)) shall be completely inserted and withdrawn a minimum of twenty times into the applicable indicator-light housing, indicator light or lampholder.
- (b) Method of connection – Between two lamp terminals.
- (c) Test current - 0.1 ampere at 6 volts d.c. open circuit voltage.

4.6.9 Contact-spring pressure (see 3.5.8). Lampholder, indicator-light housings and indicator lights, as applicable, employing spring loaded lamp contact assemblies shall be firmly mounted with their associated hardware and tested as specified in 4.6.9.1 or 4.6.9.2 as applicable.

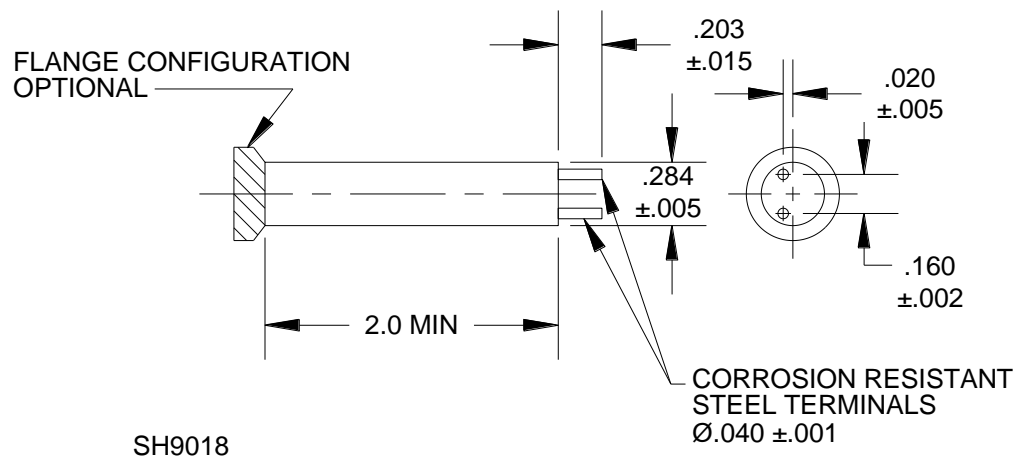
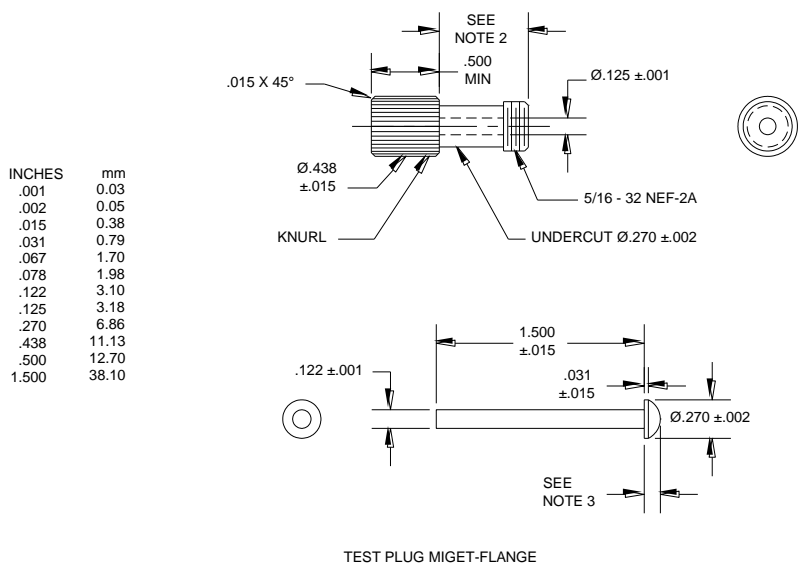
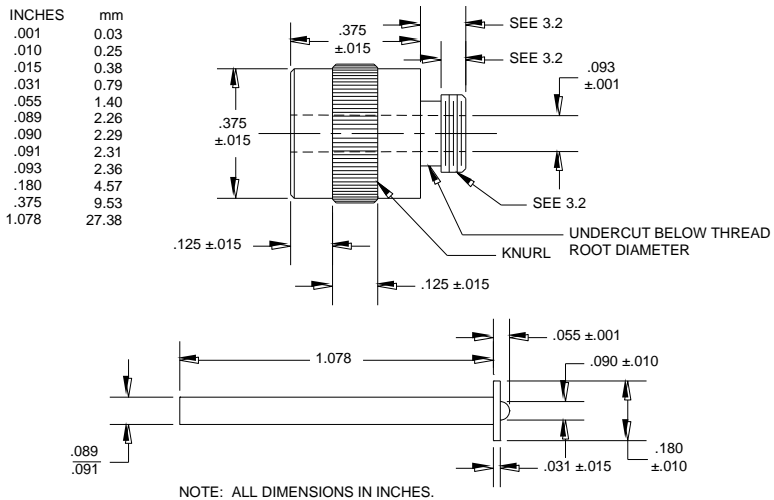

FIGURE 5. Cylindrical test plug.

MIL-DTL-3661D



NOTES:
 1. ALL DIMENSIONS IN INCHES.
 2. THE SHANK LENGTH SHALL BE AS REQUIRED (SEE 3.2).
 3. FOR INCANDESCENT A = .067 +.000
 -.002
 FOR NEON A = .078 +.000
 -.002



TEST PLUG FOR SUBMIGET-FLANGE-BASE-INDICATOR-LIGHT HOUSINGS

FIGURE 6. Test plugs for midget and submidget-flange-base-indicator-light housings (contact-spring-pressure test).

MIL-DTL-3661D

4.6.9.1 Flange base holders.

4.6.9.1.1 Midget flange base holders. For midget flange base holders, a test plug and test plug plunger (see [figure 6](#)) shall be assembled (such that the shoulder of the plunger seats on the threaded end of the plug) and the test plug shall be inserted to maximum engagement (minimum depressed position). The spring force shall then be measured and shall be within the minimum spring pressure specified. The test plug plunger shall be depressed $0.032 \pm .002$ and the spring force shall again be measured and shall not exceed the maximum spring pressure specified. Lampholder springs shall then be subjected to a minimum of 500 cycles of operation from the minimum depressed position to $.032 \pm .002$ past the minimum depressed position. Following the 500 cycles, minimum spring force shall again be measured and shall be as specified.

4.6.9.1.2 Submidget flange base holders. For submidget flange base holders, a test plug and test plug plunger (see [figure 6](#)) shall be assembled (such that the shoulder of the plunger seats on the threaded end of the plug) and the test plug shall be inserted to maximum engagement (minimum depressed position). The spring force shall then be measured and shall be within the minimum spring pressure specified. The test plug plunger shall then be depressed $0.030 \pm .002$ for incandescent bulb units; the spring force shall again be measured and shall not exceed the maximum spring pressure specified. Lampholder springs shall then be subjected to a minimum of 500 cycles of operation from the minimum depressed position to $0.030 \pm .002$ past the minimum depressed position. Following the 500 cycles, minimum spring force shall again be measured and shall be as specified.

4.6.9.2 Bayonet type holders. For bayonet base holders, the applicable test plug ([figure 3](#) or [4](#)), shall be inserted but not locked in the lamp socket. A force shall then be applied gradually to the test plug until there is sufficient pressure on the contact spring to permit the plug to be turned freely into the locking position. The contact spring force shall be measured and be as specified. Remove the "J" locking pins from the applicable test plug ([figure 3](#) or [4](#)), or make a duplicate plug without "J" pins. Insert the test plug to a depth of 0.255 inch for miniature, or 0.316 inch for candelabra types below the hook in the "J" slot (see [figure 7](#)). Then withdraw the plug until the contact reaches its fully extended positions. Repeat this operation a minimum of 500 cycles. At end of test, measure the contact spring pressure and value shall be within the limits specified.

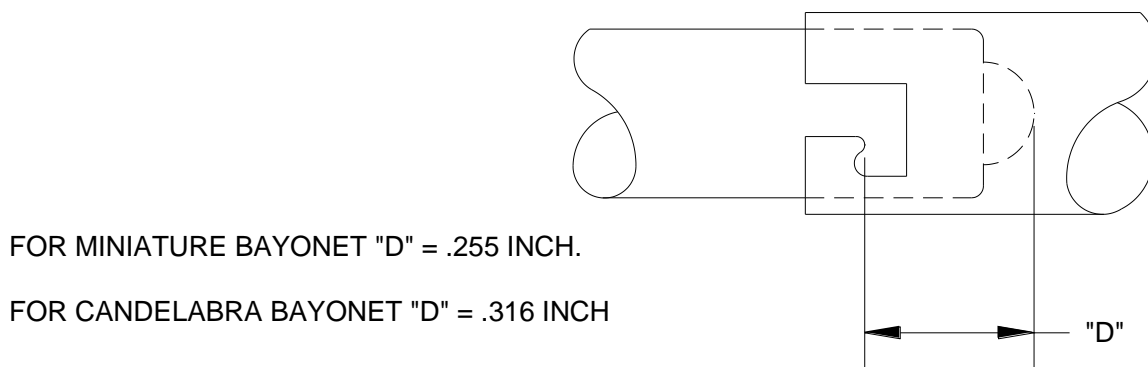

SH9020

FIGURE 7. Bayonet base - "J" locking engagement.

MIL-DTL-3661D

4.6.10 Torque (see 3.5.9).

4.6.10.1 Socket shell torque (applicable to bayonet base type sockets only). Lampholders and indicator-light housings shall be mounted by their normal mounting means. An applicable bayonet locking plug shall be inserted and locked in the socket. A torque of $4 +0/-1$; pound-inches shall be applied for one minute to the test plug at the end nearest the socket in a plane perpendicular to the centerline of the socket and in a clockwise direction. The plug shall then be released and fully engaged and released five times by normal hand pressure. The specimen shall then be lamped and energized to denote any electrical failure. The specimen shall be examined for evidence of mechanical damage as noted by any abnormal movement of the socket shell (see [3.5.9.1](#)).

4.6.10.2 Lens Torque (not applicable to non-removable lens type indicator lights (see 3.5.9.2)). The lampholder or indicator-light housing shall be mounted in its normal manner and the lens shall be fully engaged into its mating holder. A torque of 3 pound-inches shall be applied to the lens in the direction of tightening unless otherwise specified (see [3.2](#)).

4.6.10.3 Bushing torque (when applicable) (see 3.5.9.3). Lampholders and indicator-light housings shall be mounted on a rigid metal panel by their normal mounting means with its associated hardware. A torque of 20 pound-inches, unless otherwise specified (see [3.2](#)), shall be applied to the mounting nut.

4.6.10.4 Dimmer torque (applicable to lenses incorporating iris or other- dimming means) (see 3.5.9.4). Dimmer torque shall be tested as follows:

- (a) Method of mounting-The lens shall be fitted on its appropriate mating holder.
- (b) Direction of torque-With the lens securely mounted, a torque of 10 pound-inches, unless otherwise specified (see [3.2](#)), shall be applied to the dimmer portion in both clockwise and counterclockwise direction.
- (c) Measurement-The torque required to move the dimmer over the limit of its travel in both clock-wise and counterclockwise direction shall not exceed 2 pound-inches nor be less than 2 ounce-inches and the movement shall be smooth.

4.6.11 Sealing (see 3.5.10).

4.6.11.1 Watertight. Before conducting this test, all gaskets which normally can be replaced in service without disassembly of the indicator light proper, shall be disassembled from the indicator light and then reassembled with the indicator light. The indicator light shall be mounted on a test enclosure (see [figure 8](#)) by its normal mounting means, submerged in water to a depth of 6 ± 2 inches and subjected to a gradually increasing pressure at the rate of 1 pound per square inch gauge (psig) every 2 minutes, until a pressure of 15psig is reached. This pressure shall be maintained for 30 minutes. During this period of maximum pressure, shutter-type lens design indicators shall be operated for 25 cycles of complete clockwise and counterclockwise operations while submerged, for press-to-test units, the unit shall be operated for 25 cycles of complete switching actuations while submerged. During the test, the indicator light shall be observed for evidence of water leakage (see [figure 8](#)).

MIL-DTL-3661D

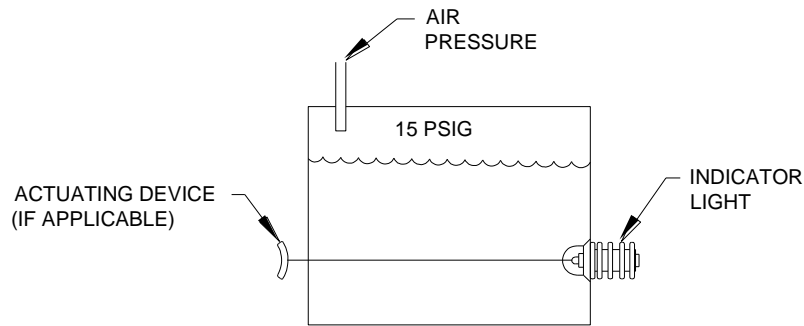

SH9021 NOTE: ENCLOSED INDICATOR LIGHTS SHALL HAVE AN OPENING IN THE BODY TO OBSERVE IF LEAKAGE OCCURS AROUND THE SEALED SHAFT AND BUSHING.

FIGURE 8. Seal test enclosure.

4.6.11.2 Dripproof. Specimens shall be subjected to the dripproof test of MIL-STD-108 with a five-gallon quantity of water flowing over the specimen for a period of five minutes duration. The water stream shall be directed within 12 inches above the test specimen.

4.6.12 Salt spray (corrosion) (see [3.5.11](#)). Lampholders, indicator lights, indicator-light housings and lenses shall be tested in accordance with method 101 of MIL-STD-202. The following details shall apply:

- (a) Test-condition letter-A.
- (b) All lampholders, indicator-light housings and lenses shall be tested individually with lamps installed in either the lampholder or lens, whichever is applicable.
 - (1) Lampholders shall be suspended by the terminals so the open end of the holder is down.
- (c) All indicator lights shall be tested with an applicable mating lens and a lamp installed. The indicator lights shall be suspended in a horizontal position.
- (d) After the test, the following examinations shall be made:
 - (1) All units shall be examined for corrosion of the base metal.
 - (2) Lenses shall be examined for visual discoloration.
 - (3) Lamps shall be removed from the specimens tested in [4.6.12](#) (b) and the inside of the socket or lens shank shall be examined for corrosion.
 - (4) Lenses shall be capable of mating with the appropriate indicator-light housing.
 - (5) Specimens tested in [4.6.12](#) (c) shall be disassembled, relamped and assembled.

MIL-DTL-3661D

4.6.13 Life (see 3.5.12.1). Indicator lights with removable lenses shall be mounted on a .125 inch aluminum panel and shall be subjected to 1,000 hours of continuous operation with the lamp of the highest wattage, operated at its maximum voltage, the holder will accommodate. Ambient temperature shall be $55 \pm 2^{\circ}\text{C}$. Non-removable lens type assemblies shall be subjected to the same test for 2,000 hours. On completion of test, the specimens shall be allowed to return to normal temperature, then subjected to the following tests:

- (a) Visual and mechanical examination.
- (b) Visual color check of lens.
- (c) Seal (if applicable to the test specimen).

For multi-lamp assemblies, all lamps that are lighted in any normal mode of operation shall be lighted during this test.

4.6.14 Press-to-test operation (when applicable) (see 3.5.12.1). The lampholder (with lamp and appropriate lens installed) shall be mounted on a rigid metal panel. A 15-pound force shall be applied directly in line with the lens until the lens traverses at least one-half its overtravel. The force shall then be reduced until the lens regains its initial position. The force shall be applied and released linearly at a rate of not more than 10 cycles per minute with a lamp duty cycle of 1 second on and 5 seconds off. Three thousand (3,000) cycles so defined shall be performed. A suitable monitoring circuit shall be used to denote proper electrical operation during this test. The following detail shall apply:

- (a) Circuit-The circuits in the lights shall be such that the indicating circuit will be open before and during the time the test circuit is closed, and the test circuit will be open before and during the time the indicating circuit is closed.

4.6.15 Life (mechanical) (see 3.5.12.2). The dimmer covers on dimming lights shall be subject to 5,000 cycles of operation from the extreme dim to the extreme bright position and return to the extreme dim position. Lamps shall not be operated during this test, but shall be energized for approximately one minute after the test to indicate whether the units are electrically operable.

4.6.16 Vibration (see 3.5.13). Lampholders, indicator-light housings and lenses shall be tested in accordance with method 204 of MIL-STD-202. The following details shall apply:

- (a) Method of mounting – Specimens shall be mounted on a rigid metal panel which is secured to a suitable base plate. Two of the specimens shall contain the highest voltage lamps that the holders can accommodate and the other specimen shall be tested with no lamp installed. All units shall have lens installed as applicable.
- (b) Specimens with lamps shall be energized at rated lamp voltage during the tests.¹
- (c) Test-condition letter-A. Unless otherwise specified (see 3.2).
- (d) During the tests the specimens with the lamps installed shall be observed for any visual light intermittency. There shall be no rotation of lens or missorientation of legend in rotatable indicator-light lenses.
- (e) After the tests, the lampholders or indicator lights that did not have a lamp installed, shall be tested for proper operation by installing a lamp and applying an appropriate voltage across the terminals. If the lampholder has a press-to-test-feature, the press-to-test-feature shall be tested for proper operation. If the lampholder has a dimmer feature, the dimmer shall be tested for proper operation,

¹ If a lamp fails, the test shall be stopped immediately and a new lamp installed. If the new lamp lights, the test shall be resumed.

MIL-DTL-3661D

4.6.17 Shock (see [3.5.14](#)). Lampholders, indicator lights, and indicator-light housings, each with appropriate lenses shall be tested as specified in 4.6.17.1 or, when specified (see [3.2](#)) in accordance with 4.6.17.2.

4.6.17.1 Method I. Specimens shall be tested in accordance with method 213 of MIL-STD-202. The following details shall apply:

- (a) Mounting method - By normal mounting means. During this test, each specimen shall carry a suitable lamp, not energized, and shall be fitted with its appropriate lens.
- (b) Test-condition--B
- (c) Number of blows-Three blows in each direction of the three principal axes (total of 18 blows).
- (d) Measurement after shock (when applicable) contact spring pressure and contact resistance shall be measured as specified in [4.6.8](#) and [4.6.9](#).
- (e) Examination - After the test, lampholders, indicator lights, indicator light housings and lenses shall be examined for chipping and cracking of materials, and loosening, bending, warping, and distortion of parts. The lampholder shall be energized immediately after the test.

4.6.17.2 Method II. Specimens shall be tested in accordance with method 207 of MIL-STD-202. The following details shall apply:

- (a) Mounting method - By normal mounting means. During this test each specimen shall carry a suitable lamp, not energized, and shall be fitted with the appropriate lens.
- (b) Measurements after shock – The specimen shall be energized immediately after the test.
- (c) Examination-After the test, lampholders, indicator lights, indicator-light housings and lenses shall be examined for chipping and cracking of materials, loosening, bending, warping, distortion of parts and satisfactory operation.

4.6.18 Moisture resistance (see [3.5.15](#)). Lampholders, indicator lights, indicator-light housings and lenses shall be tested in accordance with method 106 of MIL-STD-202, except that steps 7a and 7b shall not be performed. The following details shall apply:

- (a) Mounting-Lampholders, indicator lights, and indicator-light housings shall be mounted by normal mounting means on a noncorrosive panel positioned 15 degrees from the vertical, with the terminal end of the lampholder, indicator light, or indicator-light housing higher than the lens end. No lens or cap shall be installed on lampholders, indicator lights or indicator-light housings for this test. Lenses shall be suspended by a nylon or wax string.
- (b) Final measurements - Upon completion of a 24-hour drying period following step 6 of the final cycle, the following measurement shall be made on lampholders, indicator lights, and indicator-light housings:

(1) Dielectric withstanding voltage in accordance with paragraph [4.6.2](#).

- (c) Examination-After the test, lampholders, indicator lights, indicator-light housings and lenses shall be examined for corrosion, removal of any material finish, decomposition, leaching out, and spreading of constituent materials, and other defects.

4.6.19 Luminance (see [3.5.16](#)). Indicator lights shall be tested under dark conditions using aged and selected lamps with a $0.34 \pm .02$ mean spherical candlepower. An average of three readings shall be made across the face of the lens when the unit is illuminated, except for nomenclature display types, a minimum of 10 readings shall be taken.

MIL-DTL-3661D

5. PACKAGING

5.1 Packaging. For acquisition purposes, the packaging requirements shall be as specified in the contract or order (see [6.2](#)). When actual packaging of material is to be performed by DoD personnel, these personnel need to contact the responsible packaging activity to ascertain requisite packaging requirements. Packaging requirements are maintained by the Inventory Control Point's packaging activity within the Military Department or Defense Agency, or within the Military Department's System Command. Packaging data retrieval is available from the managing Military Department's or Defense Agency's automated packaging files, CD-ROM products, or by contacting the responsible packaging activity.

6. NOTES

(This section contains information of a general or explanatory nature that may be helpful, but is not mandatory.)

6.1 Intended use. The lampholders, indicator lights, indicator-light housings and lenses covered by this specification are intended for use as panel display and indicating functions on electrical, electronic, and communication equipment.

6.2 Acquisition Requirements. Acquisition documents should specify the following:

- a. Title, number and date of this specification.
- b. Title, number, and date of the applicable specification sheet, and the complete type designation (see [1.2](#) and [3.2](#)).
- c. Whether lens is to be marked with symbols and legend (see [3.4.9.5](#)).
- d. Whether lamps are to be furnished, and if so, indicate lamp number and whether to be installed.
- e. When a first article is required (see [3.1](#), [4.4](#) and [6.3](#)).
- f. Packaging requirements (see [5.1](#)).

6.2.1 Indicator lights. Indicator lights with removable lens designs (excluding nomenclature display type units), may be procured by combining the type designation of the indicator-light housing and the indicator-light lens; for example LH76/1-LC16BN.

6.3 First article. When a first article inspection is requested, it should be inspected and approved under the appropriate provisions of Federal Acquisition Regulation (FAR) 52.209. The first article should be pre-production sample. The contracting officer should specify the appropriate type of first article and the number of units to be furnished. The contracting officer should include specific instructions in all acquisition documents regarding arrangements for selection, inspection, and approval of the first article.

6.4 Dissimilar metals. Dissimilar metals are defined in [table VII](#).

- (a) Contact between a member of any one group and another member of the same group is considered as contact of similar metals. Contact between a member of one group and a member of any other group is considered as contact of dissimilar metals, except for zinc, tin, and cadmium, as listed in groups II and III, and for stainless steel as listed in groups II, III, and IV.
- (b) Unless specifically indicated by the procuring activity, all other metals are considered dissimilar with respect to each other and with respect to any of the materials listed in [table VII](#).
- (c) Where reference is made to a metal in a particular group, the reference applies to the metal on the surface of the part; that is, zinc means zinc castings, as well as zinc electroplate, zinc hot dip, or zinc metal spray.

MIL-DTL-3661D

- (d) Different metals in contact, even though similar, should be employed in assemblies in such a manner that the smaller part is cathodic or protected and the larger part is anodic or corroded, if any corrosion takes place.

TABLE VII. Grouping of metals.

Group I	Group II	Group III	Group IV
Magnesium alloys (most anodic)	Anodized aluminum Aluminum Aluminum alloys Zinc Cadmium Tin Stainless steel	Zinc Cadmium Steel Lead Tin Stainless steel	Copper and its alloys Nickel and its alloys Chromium Stainless steel Gold Silver (most cathodic)

6.5 Definitions. For the purpose of this specification, the following definitions apply:

6.5.1 Lampholder. A lampholder is an electrical device which accommodates a lamp both electrically and mechanically, but does not provide for the use of an indicator-light lens.

6.5.2 Indicator light. An indicator light is an indicator-light housing and indicator-light lens assembled as a unit.

6.5.3 Indicator-light housing. An indicator-light housing is an electrical device which accommodates a lamp both electrically and mechanically, and provides for the use of an indicator-light lens.

6.5.4 Indicator-light lens. An indicator-light lens is a device having a mounting means and a glass or plastic window through which light is transmitted.

6.6 Usable lamps. The usable lamps (see [3.2](#)) may be purchased under MIL-DTL-6363 (Lamp, Incandescent, Aircraft Service, General Specification for) or MIL-DTL-15098 (Lamps, Glow, General Specification for), as applicable.

6.7 Subject term (keyword) listing.

Lamp
Plug-in
Press-to-test

6.8 Changes from previous issue. The margins of this specification are marked with vertical lines to indicate where changes from the previous issue were made. This was done as a convenience only and the Government assumes no liability whatsoever for any inaccuracies in these notations. Bidders and contractors are cautioned to evaluate the requirements of this document based on the entire content irrespective of the marginal notations and relationship to the previous issue.

MIL-DTL-3661D

Custodians:

Army - CR
Navy - AS
Air Force - 99

Preparing activity:

DLA-GS2

(Project Number – 6210-2014-001)

Review activities:

Army – AR, CR4, EA, MI
Navy – MC, OS, SH
Air Force - 7

NOTE: The activities listed above were interested in this document as of the date of this document. Since organizations and responsibilities can change, you should verify the currency of the information above using the ASSIST database at <https://assist.dla.mil/>.