

INCH-POUND

MIL-DTL-32385/2

14 July 2011

SUPERSEDING

MS90335D

5 January 1996

DETAIL SPECIFICATION SHEET

CONTACT, RECEPTACLE, CENTER SCREW CONTACT POSITIVE, PANEL GROUND TYPE

This specification is approved for use by all Departments and Agencies of the Department of Defense.

The requirements for acquiring the product described herein shall consist of this specification sheet, MIL-DTL-32385, and QPL-32385.

INTENDED USE:

1. The connectors covered by this specification sheet are intended for use on control and instrument panels for aircraft, ground, and shipboard applications.

REQUIREMENTS:

1. Material: Material shall be in accordance with MIL-DTL-32385.
2. Finish: Finish shall be in accordance with MIL-DTL-32385.
3. Design: Design shall be in accordance with MIL-DTL-32385.

MIL-DTL-32385/2

NOTES:

1. The part or identifying number (PIN) consists of the letters MS, the specification number, and the dash number taken from table 1.

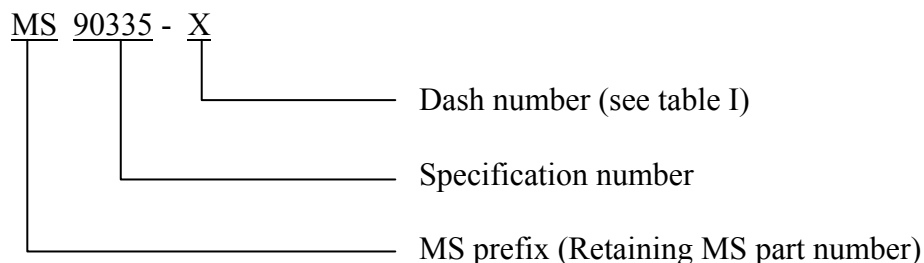

TABLE I. Dash number PIN cross-reference data.

Dash number ¹	MS90335D PIN	MIL-DTL-32385/2 PIN
-3	MS90335-3	MS90335-3
-4	MS90335-4	MS90335-4

¹ See figure 1.

2. Interpret figure in accordance with ASME Y14.5.
3. Female center contact fingers closed down uniformly to meet 4 ounce minimum withdrawal force with 0.079 diameter pin before and after 3 insertions of a 0.082 diameter pin.
4. When mated with MIL-DTL-32385/5, or /6 plug that has been inserted to a depth of 0.140 ± 0.005 inch, the connector shall have a minimum withdrawal force of 3 pounds of force (lbf) and a maximum withdraw force of 10 lbf.
5. The manufacturer's identification mark shall be permanently stamped in the metal part of the connectors.
6. The current capability loading of the connectors is limited to the current-carrying capacity of the wire used in the associated interconnecting cabling.
7. In the event of a conflict between the text of this document and the references cited herein, the text of this document takes precedence.
8. Unless otherwise specified, issues of reference documents are those in effect at the time of solicitation.
9. Interchangeability relationship: MS90335-3 and MIL-DTL-32385/2-3 parts are universally, functionally and dimensionally interchangeable. MS90335-4 and MIL-DTL-32385/2-4 parts are universally, functionally and dimensionally interchangeable.

MIL-DTL-32385/2

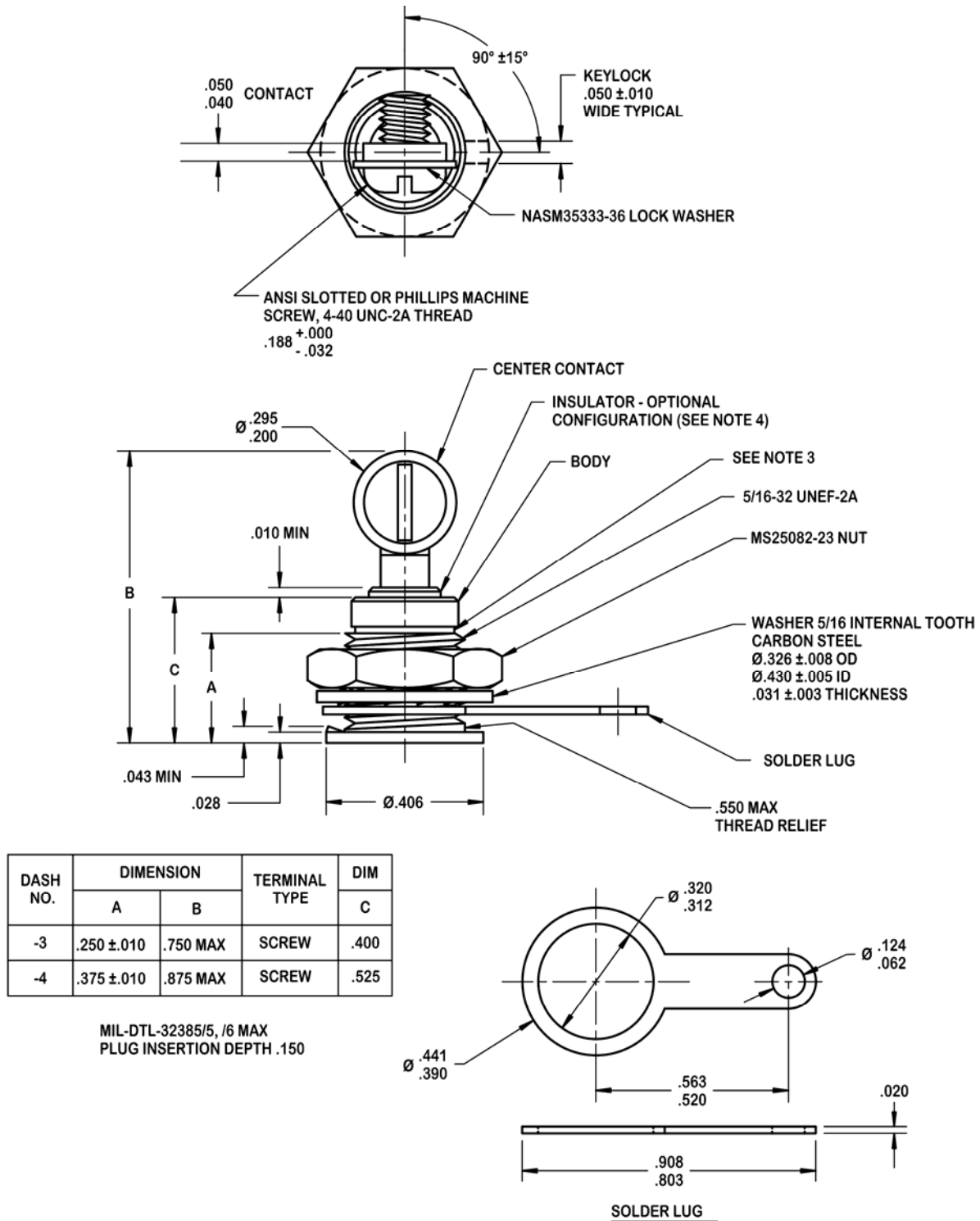

NOTES:

- All dimensions are in inches.
- Tolerances: Dimensions ± 0.005 unless otherwise specified.
- Captivation of insulator and center contact will maintain 12 lbf when applied from interface end.
- Insulator shall not exceed diameter of body.

FIGURE 1. Connector, receptacle, center screw contact positive, panel ground type.

MIL-DTL-32385/2

Custodians:

Army - AV
Navy - AS
Air Force - 85
DLA - GS

Preparing Activity:

DLA - GS2

(Project 5935-2011-032)

Review Activities:

Navy - MC, SH

NOTE: The activities listed above were interested in this document as of the date of this document. Since organizations and responsibilities can change, you should verify the currency of the information above using the ASSIST database at <https://assist.daps.dla.mil/>.