

INCH-POUND

MIL-DTL-27422D
30 January 2007
SUPERSEDING
MIL-DTL-27422C
14 January 2002

DETAIL SPECIFICATION
FOR THE
TANK, FUEL, CRASH-RESISTANT, BALLISTIC-TOLERANT, AIRCRAFT

This specification is approved for use by all Departments and Agencies of the Department of Defense.

1. SCOPE

1.1 Scope. This specification covers the requirements and verification testing for crash-resistant, ballistic-tolerant fuel cell for use in rotorcraft and tilt rotorcraft. Exact design criteria such as fuel cell dimensions, total weight, and interface requirements will be dependent upon the intended aircraft specified in the contract or purchase order.

1.2 Classification. Crash-resistant, ballistic-tolerant, fuel cells will be of the following types and classes:

1.2.1 Class.

Class A - Flexible fuel cell construction

Class B - Semi-rigid or self-supporting fuel cell construction

Beneficial comments (recommendations, additions, deletions) and any pertinent data which may be of use in improving this document should be addressed to: U.S. Army Aviation and Missile Command, Attn: AMSAM-RD-SE-TD-ST by using the Standardization Document Improvement Proposal (DD Form 1426) appearing at the end of this document or by letter.

MIL-DTL-27422D

1.2.2 Type. (see 6.1)

Type I - Self-sealing or partially self-sealing

Type II - Non-self-sealing

1.2.3 Protection level.

Level A - Cell is completely self-sealing against .50 caliber and 20 mm (entry wound only for 20 mm).

Level B - Part of the cell is non-self-sealing and part is self-sealing against .50 caliber and 20 mm (entry wound only for 20 mm).

Level C - Part of the cell is self-sealing against .50 caliber and part of the cell is self-sealing against 14.5 mm.

Level D - Cell is completely self-sealing against 14.5 mm and 20 mm (entry wound only for 20 mm).

Level E - Part of the cell is self-sealing against 14.5 mm and 20 mm (entry wound only for 20 mm) and part of the cell is non-self-sealing.

2. APPLICABLE DOCUMENTS

2.1 General. The documents listed in this section are specified in sections 3 and 4 of this specification. This section does not include documents cited in other sections of this specification or recommended for additional information or as examples. While every effort has been made to ensure the completeness of this list, document users are cautioned that they must meet all specified requirements documents cited in sections 3 and 4 of this specification, whether or not they are listed.

2.2. Government documents.

2.2.1 Specifications, standards, and handbooks. The following specifications, standards, and handbooks form a part of this document to the extent specified herein. Unless otherwise specified, the issues of these documents are those listed in the issue of the Department of Defense Index of Specifications and Standards (DoDISS) and supplement thereto, cited in the solicitation (see 6.2(b)).

SPECIFICATIONS

DEPARTMENT OF DEFENSE

MIL-DTL-5624

Detail Specification Turbine Fuel,
Aviation, Grades JP-4, JP-5 and JP-
5/JP-8 ST

MIL-DTL-27422D

MIL-DTL-83133

Detail Specification Turbine Fuel,
Aviation Kerosene Types, NATO F-34
(JP-8), NATO F-35, and JP-8+100

STANDARDS

FEDERAL

FED-STD-191

Textile Test Methods

FED-STD-601

Rubber, Sampling and Testing

FED-STD-791

Lubricants, Liquid Fuels, and Related
Products; Methods of Testing

DEPARTMENT OF DEFENSE

MIL-STD-129

Military Marking

MIL-STD-130

Identification Marking of US Military
Property

MIL-STD-662

V₅₀ Ballistic Test for Armor

MIL-STD- 801

Inspection and Acceptance
Standards for Fuel Cells and Fittings

(Unless otherwise indicated, copies of the above specifications, standards, and handbooks are available from the Standardization Document Order Desk, 700 Robbins Avenue, Building 4D, Philadelphia, PA 19111-5094.)

2.2.2 Non-Government publications. The following documents form a part of this document to the extent specified herein. Unless otherwise specified, the issues of the documents which are DoD adopted are those listed in the issue of the DoDISS cited in the solicitation. Unless otherwise specified herein, the issues of documents not listed in the DoDISS are the issues of the documents cited in the solicitation (see 6.2).

AMERICAN SOCIETY FOR TESTING AND MATERIALS (ASTM)

ASTM D381

Standard Test Method for Gum Content
in Fuels by Jet Evaporation

ASTM D413

Standard Test Methods for Rubber
Property – Adhesion to Flexible
Substrate

MIL-DTL-27422D

ASTM D471	Standard Test Method for Ref. B Rubber Property – Effect of Liquids
ASTM D910	Standard Specification for Aviation Gasolines

(Application for copies should be addressed to the American Society for Testing and Materials (ASTM), 100 Barr Harbor Drive, West Conshohocken, PA 19429-2959).

2.4 Order of precedence. In the event of a conflict between the text of this document and the references cited herein, the text of this document takes precedence. Nothing in this document, however, supersedes applicable laws and regulations unless a specific exemption has been obtained.

3. REQUIREMENTS

3.1 Application. The requirements of this specification apply only to fuel cells that are to be installed within the aircraft, or as specified by the Procuring Activity. A tank is defined as a single fuel cell or group of fuel cells interconnected, and the components attached thereto.

3.2 Materials. Materials conforming to industry or contractor's (see 6.4(a)) specifications may be used provided those specifications contain provisions for verification tests. However, the use of magnesium is prohibited and cadmium-plated parts shall not be used when those parts will be exposed to fuel.

3.3 Design criteria.

3.3.1 Classification requirements. The fuel cell shall be designed for the class, type, and protection level described below in order to meet the applicable aircraft requirements as stated in the contract or purchase order:

3.3.1.1 Class. (see 4.5.8.4)

3.3.1.1.1 Class A. The Class A fuel cell shall have flexible construction.

3.3.1.1.2 Class B. The Class B fuel cell shall have semi-rigid or self-supporting fuel cell construction.

3.3.1.2 Type. (see 4.5.8.4)

3.3.1.2.1. Type I. A Type I fuel cell shall be self-sealing or partially self-sealing.

3.3.1.2.2. Type II. A Type II fuel cell shall be non-self-sealing.

3.3.1.3 Protection level. (see 4.5.8.4)

MIL-DTL-27422D

3.3.1.3.1 Level A. The fuel cell designed for Level A protection shall be completely self-sealing against .50 caliber and 20 mm (entry wound only for 20 mm).

3.3.1.3.2 Level B. Part of the fuel cell designed for Level B protection shall be non-self sealing and part of the cell shall be self-sealing against .50 caliber and 20 mm (entry wound only for 20 mm).

3.3.1.3.3 Level C. Part of the fuel cell designed for Level C protection shall be self-sealing against .50 caliber and part of the cell shall be self-sealing against 14.5 mm.

3.3.1.3.4 Level D. The fuel cell designed for Level D protection shall be completely self-sealing against 14.5 mm and 20 mm (entry wound only for 20 mm).

3.3.1.3.5 Level E. Part of the cell designed for Level E protection shall be self-sealing against 14.5 mm and 20 mm (entry wound only for 20 mm) and part of the cell shall be non self-sealing.

3.3.1.4 Type specification. For Type I fuel cells requiring levels B and E protection, the portions of the cells to be self-sealing and non-self-sealing shall be as specified by the Procuring Activity. The non-self-sealing portions shall conform to the requirements for Type II cells. For Type I cells of level C protection, the portions of the cell to be protected against .50 caliber and 14.5 mm shall be as specified by the Procuring Activity. (see 4.5.9.1 and 4.5.9.3)

3.3.2 Dimensions. (see 4.6.2.1.2)

3.3.2.1 Class A cell dimensions. All outside dimensions of a Class A fuel cell (including attachment points) shall be no less than the corresponding dimensions of the fuel cell cavity given in the applicable aircraft documentation specified by the contract or purchase order. The amount of oversize between attachment points and between any attachment point and the nearest edge shall not exceed 0.250 inch. The fuel cells shall be designed so that they can be installed by hand, without the need of forcing tools. Additionally, the fuel cells shall be designed so that there will be no evidence of wrinkles caused by stress following installation of the cell.

3.3.2.2 Class B cell dimensions. All outside dimensions of the Class B fuel cell (including attachment points) shall be no less than the corresponding dimensions of the fuel cell cavity given in the applicable aircraft documentation specified by the contract or purchase order.

3.3.3 Capacity.

3.3.3.1 Class A cell capacity. The capacity of the Class A fuel cell shall be as stated in the applicable aircraft documentation specified by the contract or purchase order.

3.3.3.2 Class B cell capacity. The capacity of the Class B cell shall be according to the applicable aircraft documentation specified by the contract or purchase order.

MIL-DTL-27422D

However, the fuel level versus volume curve on production cells shall be within 1.5 percent to the average fuel level versus volume curve. (see 4.3.3.2.1 and 4.7.4)

3.4 Construction.

3.4.1 Inner layer ply. For Type I cells the inner layer ply and barrier shall prevent sealant activation. For either Type I or Type II cells the diffusion rate of fuel shall be no greater than .025 fluid ounce per square foot within a 24-hour period. (see 4.4.5.2)

3.4.2 Fabric ply. The edges of material in the lap seams of any ply in a fuel cell shall not be superimposed on parallel seams of an adjacent ply. (see 4.4.5.3)

3.4.3 Sealant. The Type I fuel cell shall include a sealant to ensure the cell meets the requirements of 3.3.1.1.1 and 3.3.1.1.2 for either Class A or B, as specified in the contract or purchase order. (see 4.5.8.4 and 4.7.12)

3.4.4 Fittings. Fuel cell fittings shall not leak. Additionally, fittings for fuel cells shall conform to the best commercial practices consistent with meeting the design guidance and requirements in this specification, unless otherwise specified in the applicable aircraft documentation cited in the contract or purchase order. Single plane fittings shall be used wherever practicable. The use of through-bolts is prohibited where a bolt head seal is required. (see 4.7.1)

3.4.5 Screw thread. MIL-S-8879 may be used as guidance relative to screw thread requirements. The use of pipe threads is prohibited. (see 4.7.1)

3.5 Performance.

3.5.1 Fuel types. Fuel cells designed using this specification shall be compatible with all commercial and military type fuels. Primary military fuels are those meeting the requirements of ASTM-D910, MIL-DTL-5624 and MIL-DTL-83133. (see 4.3.3)

3.5.2 Fuel cell strength. The fuel cell, when installed in the aircraft for which it is designed, shall withstand:(see 4.4.3 and 4.4.4)

- (a) Flexing resulting from vibration caused by the aircraft
- (b) Impact loads incident to takeoff, taxiing, and landing (including catapulting and arresting)
- (c) Hydraulic surge of fuel incident to dynamic conditions of flight
- (d) Hydraulic surge of fuel incident to gunfire

- (e) Pressure loads resulting from hydrostatic head of fuel during level flight or maneuvers, and resulting from neutral gases used to pressurize fuel tanks

- (f) Crash loads as specified in the applicable aircraft documentation.

3.5.3 Leaking and tearing following gunfire.

MIL-DTL-27422D

3.5.3.1 Type I fuel cell. (see 4.5.9.1)3.5.3.1.1 Leaking.

3.5.3.1.1.1 Ambient temperature A Type I fuel cell shall dry or damp seal (6.4(d) and 6.4(c)) within 2 minutes in ambient temperature (Phases I and II).

3.5.3.1.1.2 Low temperature. A Type I fuel cell shall dry or damp seal (see 6.4(d) and 6.4(c)) within 4 minutes or less following gunfire in temperatures as low as -40° F (Phase I only).

3.5.3.1.2 Tearing. A Type I fuel cell shall withstand gunfire without tearing in ambient temperatures and only sustain cracking of the inner liner when gunfire is encountered in low temperatures.

3.5.3.2 Type II fuel cell. A Type II fuel cell tear shall be: (see 4.5.9.3)

(a) Not larger than 4 inches measured radially from the edge of the wound at each entry and exit point, in low temperatures, or

(b) Not larger than 3 inches measured radially from the edge of the wound at each entry and exit point in ambient temperatures.

(c) One that radiates from the bullet hole as a direct result of shrapnel or structure damage.

3.5.4 Operating temperature. Types I and II fuel cells shall operate throughout an ambient temperature range of -65° to +160° F and fuel temperature range of -65° to +135° F. (see 4.7.9)

3.5.5 Weight. The weight of fuel cells designed using this specification shall be in accordance with the applicable aircraft documentation specified by the contract or purchase order. The weight of production fuel cells shall be within 5 percent of the average weight of the first 10 production fuel cells. (see 4.6.2.1.3)

3.6 Finish.

3.6.1 External surfaces. The external surfaces of cells shall be protected against the action of ozone, ultraviolet light, and hydrocarbon fuels. All external surfaces of cells shall limit diffusion of fuel sufficiently to prevent sealant activation when tested in accordance with 4.5.8.1, or when specified by the Procuring Activity. When specified by the Procuring Activity, the resistance to mechanical damage shall be protected against impact and abrasion (see 4.5.6 and 4.5.7).

3.6.2 Steel parts. Any steel parts of the fuel cell shall not corrode when subjected to routine uses as specified in the applicable aircraft document. (see 4.6.2.1)

MIL-DTL-27422D

3.6.3 Aluminum-alloy parts. Aluminum-alloy parts for the fuel cell shall not corrode when subjected to routine uses as specified in the applicable aircraft document. (see 4.6.2.1)

3.7 Markings. (see 4.6.2.1)

3.7.1 Access door covers. The exterior surface of all access door covers of the fuel cell shall be legibly marked "OUTSIDE."

3.7.2 Durable markings. Marking for the exterior surface of all access door covers of the fuel cell shall be legible for the life cycle of the fuel cell.

3.7.3 Torque value marking. The torque value required to assemble the fittings and accessories to the fuel cell shall be legibly marked:

- (a) On or adjacent to each fitting and accessory
- (b) For the life cycle of the fuel cell.

3.7.4 Preformed packing. Where "O" rings are required to seal fuel cell fittings, the part number of the applicable "O" ring shall be marked adjacent to or on the fitting where it can be easily read.

3.7.5 Fuel cell and assembly markings.

3.7.5.1 Identification. The fuel cell, assemblies, and parts designed using this specification shall be marked for identification in accordance with MIL-STD-130. Unless otherwise specified by the contract or purchase order, the following markings shall be added:

- (a) Aircraft contractor (see 6.4(a))
- (b) Aircraft model(s) and fuel cell location
- (c) Specification MIL-DTL-27422C, Type _____ Protection level _____
Class _____
- (d) Month and year of manufacture
- (e) Construction number

3.7.5.2 Location of identification. Identification (e.g., nameplate, stencil, etc.) shall be readily visible after removal of aircraft access panels, deck doors, etc.

3.8 Workmanship. Workmanship shall be in accordance with commercial manufacturing practices covering this type of equipment. MIL-STD-801 may be used as a guide. (see 4.6.2.1.4)

3.9 Vulcanized sealant. The vulcanized sealant shall be free of foreign matter and the thickness shall agree with the approved construction within the established commercial manufacturing tolerances, as described in the fuel cell manufacturer's (see 6.4(g)) specification. (see 4.4.5.1)

MIL-DTL-27422D

3.10 Fuel cell cleaning. The fuel cells shall be thoroughly cleaned of rubber particles, dirt, sand, metal chips, welding flux, or other foreign material while being assembled and following final assembly. (see 4.6.2.1)

3.11 Stability. The fuel cell shall be not more than two years old from the date of initial cure to the date of delivery of the cell, as determined by the contract or purchase order.

3.12 Service life. It is desired that the service life of a fuel cell covered by this specification be equivalent to that of the aircraft life in which they are installed.

4. VERIFICATION

4.1 Classifications of verification tests. Verification requirement tests specified herein are classified as follows:

- (a) Phase I test samples (4.3)
- (b) Phase I tests (4.4)
- (c) Phase I construction tests (4.5)
- (d) Phase II product conformance tests (4.6.1)
- (e) Phase II tests (4.7)

4.2 Phase I design verification tests. Phase I design verification tests are those tests accomplished on samples of the materials and construction (including fittings and methods of attachment) to be used in the manufacture of crash-resistant, ballistic-tolerant, aircraft fuel cells. All fuel cells supplied using this specification shall be tested using the test methods identified in Table I to verify that the fuel cells meet the requirements given in section 3.

TABLE I. Phase I design verification tests.

Test	Paragraph
Materials	
Non-volatile gum residue	4.4.1
Stoved gum residue	4.4.2
Inner liner strength	4.4.3 or 4.4.4

MIL-DTL-27422D

TABLE I. Phase I design verification tests - Continued.

Test	Paragraph
Materials	
Permeability	4.4.5
Seam adhesion	4.4.5.3
Slit resistance	4.4.5.5
Inner liner adhesion	4.4.5.6 (Type I cells only)
Stress aging	4.4.5.7
Constant rate tear	4.5.1
Impact penetration	4.5.2
Impact tear	4.5.3
Panel strength calibration	4.5.4
Fitting strength	4.5.5
**Impact resistance	4.5.6
**Abrasion resistance	4.5.7
Test Cubes	
Cube 1	
Fuel resistance	4.5.8.1
Slosh resistance (Phase I)	4.5.8.3
Stand test (Phase I)	4.5.11
Cube 2	
Crash impact (Phase I)	4.5.8.2
Cube 3	
Low temperature gunfire	4.5.8.4.2
Fuel aging	4.5.10
Cube 4	
Normal temperature gunfire	4.5.8.4.3
Fuel aging	4.5.10

** When specified by the Procuring Activity.

4.3 Phase I test samples.

4.3.1.1 Test samples. Phase I test samples shall include the following:

(a) Four test cubes, to fit the metal container shown in Figure 1. Each test cube shall contain a fitting centered on the top surface of the cube. The fitting shall be at least a 10-inch by 16-inch oval of sufficient strength to pass the drop test (see 4.5.8.2). If a non-crash resistant fitting is used for the drop test it may be reinforced with a fabric collar extending 3 inches beyond the flange tip. For Type I cells, protection levels B and

MIL-DTL-27422D

E, the non-sealing portion of the test cube shall be fabricated from a material meeting the requirements of this specification for Type I cells. The self-sealing portion of these cubes shall be fabricated using the applicable protection level. For Type I cells the samples required by (d), (e), (f), (g), and (h) are to be from the self-sealing construction.

(b) Eight metal side panels in accordance with sheet 5 of Figure 1.

(c) Eight sheets of backing material 27 by 30 inches and two sheets of backing material 30 by 30 inches.

(d) Two 12 by 12-inch samples of complete fuel cell construction.

(e) Twenty samples of complete fuel cell construction, dimensionally in accordance with Figure 4. The samples shall be cut in such a manner that five have the 7-inch dimension parallel to the warp threads of the exterior ply, five have the 7-inch dimension at 90° to the right of the warp threads of the exterior ply, and five have the 7-inch dimension at 45° to the left of the warp threads of the exterior ply, and five have the 7-inch dimension at 45° to the right of the warp threads of the exterior ply.

(f) Twenty samples of complete fuel cell construction, in accordance with Figure 5.

(g) Twenty samples of complete fuel cell construction, dimensionally in accordance with Figure 6. Figure 6 samples shall be cut in the same manner as Figure 4.

(h) One sample of inner layer ply, without barrier, approximately 900 square inches in area with seam. This sample is required only for constructions having inner layer ply seams.

(i) One sample of inner layer ply, with barrier, approximately 900 square inches in area without a seam.

(j) One sample 6 by 6 by 0.075 to 0.125-inch inner layer material, without barrier.

(k) Four samples of complete construction to fit the clamping flange of Figure 8 with a centrally mounted 4-inch fitting. Samples shall not be pre-plasticized with fluid prior to submission.

(l) Six samples of complete construction as required to fit the clamping flange of Figure 7.

4.3.2 Test conditions. In addition to the test conditions set forth in specific tests, the conditions specified herein shall apply.

4.3.2.1 Test fluid. Test fluids used in the design verification process shall include, but not be limited to, test fluids described in ASTM D471 (Ref Fuel A and B), and JP-5 aviation fuel, and JP-8 aviation fuel.

MIL-DTL-27422D

4.3.2.2 Temperature tolerances. Unless otherwise specified, the following temperature tolerance shall be maintained:

<u>Specified temperature</u>	<u>Tolerance</u>
Above 100° F	±10° F
Below 100° F	±5° F

4.3.2.3 Special environment. When the test methods specified herein do not represent the cell environment, for example, temperatures resulting from aerodynamic heating of 160° F, the test method should be modified as agreed upon by the contractor (see 6.4(a)) and the Procuring Activity to simulate operation conditions.

4.3.3 Stand test (sampling).

4.3.3.1 Exterior fuel resistance test. When specified by the Procuring Activity, prior to the stand test, Type I fuel cells shall be subjected to the fuel resistance of exterior surface test specified in 4.5.8.1. Fuel cells shall be tested in accordance with the time cycle listed below. An alternate procedure for conducting this 60-day test may be used if approved by the Procuring Activity. Upon completion of this test, the outside surface of the fuel cell shall be dried with a cloth, and the fuel cell shall be stored in an airtight bag or immediately installed in the cavity used for the stand test.

4.3.3.2 Interior fuel resistance test.

4.3.3.2.1 Time cycle. Class A fuel cells shall be collapsed and held strapped for 30 minutes in a position comparable to that encountered prior to installation in its respective aircraft cavity, then released, and adequately supported. Both Class A and Class B fuel cells shall be filled with fluid per ASTM D471 (Ref B Fuel) or JP-5 aviation fuel/JP-8 aviation fuel containing a minimum of 25 percent aromatics. During the filling process, the capacity test (see 4.7.4) shall be conducted on Class B cells to determine conformance with 3.3.3.2. Fuel cells shall then be tested in accordance with the following time cycle:

(a) First fuel cell selected	30 days
(b) Second fuel cell	30 days
(c) Third fuel cell	30 days

4.3.3.2.2 Additional interior fuel resistance tests. The time cycle in 4.3.3.2.1 shall be repeated for additional fuel cells chosen in accordance with 4.6.3.2 for the duration of the contract. Upon completion of the test and at the intermediate inspections, the fuel cells shall be carefully examined for any evidence of swelling, separation, blistering, dissolution or activation of the sealant material.

4.3.4 Dissection. The sectioned portion of each fuel cell selected in 4.6.3.3 shall be examined. MIL-STD-8016 may be used as a guide.

MIL-DTL-27422D

4.4 Phase I tests.

4.4.1 Non-volatile gum residue. A 5-gram sample of the inner layer, up to the barrier, shall be cut into approximately 0.062 inch squares and placed in a flask containing 250 ml. of ASTM D471 Ref Fuel B test fluid and allowed to stand for 48 hours at $77^{\circ} \pm 5^{\circ}$ F. The contaminated test fluid shall be decanted off, and the nonvolatile gum residue shall be determined by Method 3302 of FED-STD-791 (ASTM D381-64) except that the total evaporation time shall be 45 minutes. The nonvolatile material shall not exceed 60 mg. per 100 ml. of contaminated fluid.

4.4.2 Stoved gum residue. The beakers containing the nonvolatile material shall be placed in an appropriate bath maintained constantly at a temperature of $572^{\circ} \pm 9^{\circ}$ F for 30 minutes. After cooling in a closed container, the beakers shall be weighed. The stoved gum residue shall not exceed 20 mg. per 100 ml. of the contaminated fluid.

4.4.3 Gum inner liner strength. The tensile strength of the gum inner layer ply, without barrier, shall be determined in accordance with FED-STD-601, Method 4111, before and after immersion in ASTM D471 Ref Fuel B test fluid for 72 hours at a temperature of $135^{\circ} \pm 3^{\circ}$ F. The tensile strength shall also be determined before and after immersion in a solution of 25 percent inhibitor and 75 percent water, by volume, for 72 hours at a temperature of $135^{\circ} \pm 3^{\circ}$ F. The tensile strength reduction shall be reported to the Procuring Activity. The tensile strength shall not be reduced more than 50 percent for fuel immersion and 20 percent for water immersion calculated on the basis of the original cross-sectional area.

4.4.4 Fabric inner liner strength. The tensile strength of the fabric inner layer ply, without barrier, shall be determined in accordance with FED-STD-191, Method 5100 before and after immersion in ASTM D471 Ref Fuel B test fluid for 72 hours at a temperature of $135^{\circ} \pm 3^{\circ}$ F. The tensile strength shall also be determined before and after immersion in a solution of 25 percent inhibitor and 75 percent water, by volume, for 72 hours at a temperature of $135^{\circ} \pm 3^{\circ}$ F. The tensile strength shall not be reduced more than 20 percent for fuel immersion and 50 percent for water immersion calculated on the basis of the original cross-sectional area.

4.4.5 Permeability.

4.4.5.1 Preparation of test specimens. For fuel cells employing vulcanized inner liners, the uncured inner liner shall be applied to a 10 by 10-inch piece of corrugated fiberboard coated on one side with a suitable water-soluble breakaway agent. The exposed surface of the inner liner shall be coated with prime cement and barrier resin (if required) that conform to the manufacturer's (see 6.4(g)) specifications. The assembly shall then be wrapped with fuel cellophane and covered with a suitable waterproof bag. The assembly shall be vulcanized by the method used in regular production. After vulcanization, the waterproof bag and cellophane shall be removed. The inner liner shall then be removed from the fiberboard. The free moisture shall then be wiped from the assembly, and the assembly shall be conditioned for 24 hours at a temperature of 77° F and a relative humidity of 50 to 65 percent. For fuel cells using non-vulcanized,

MIL-DTL-27422D

continuous inner liners, the inner liner shall be applied by production methods on a 10 by 10-inch piece of corrugated fiberboard coated on one side with a suitable release agent. The exposed surface of the inner liner shall be coated with barrier material that conforms to manufacturer's specifications. The assembly shall then be cured or otherwise processed by the method used in regular production. The inner liner shall then be removed from the fiberboard. The assembly shall be conditioned for 24 hours at a temperature of 77° F and a relative humidity of 50 to 65 percent. After the conditioning, two discs 2.5 inches in diameter shall be cut from the panel prepared above. One hundred ml. of ASTM D471 Ref Fuel B test fluid shall be placed in a cup conforming to Figure 3. A suitable nylon solution shall be applied to the face of the cup flange covering the area inside the bolt circle. When the nylon solution is almost dry, the test disc shall be applied to the cup with the barrier, if any, facing outward. Other sealing materials may be used if approved by the Procuring Activity. The assembly shall be completed by attaching the bolting ring shown on Figure 3 and tightening the bolts in accordance with the following:

<u>Inner liner type</u>	<u>Bolt torque in pound inches</u>
Gum stocks	5 to 10
Coated fabrics	15 to 20
Unsupported plastic films	20 to 25

4.4.5.2 Conduct of test. The cups, prepared as specified 4.4.5.1, shall be placed in a suitable rack and maintained at a temperature of 77° F and a relative humidity of 50 to 65 percent for a 1-hour equilibration period. The cup shall be weighed to the nearest 0.005 gram and placed in the rack with the face of the cup facing upward. The cup shall be maintained at a temperature of 77° ±5° F and a relative humidity of 50 to 65 percent for a 24-hour period. The cup shall then be weighed to check for the integrity of the seal. The cup shall be inverted (test disc down) in a rack that permits free access of air to the test disc. The cups shall be weighed at the end of the third, fifth, and eighth day after inverting. Defective films or leaks resulting from faulty assembly will usually be found when weighing on the third day. The diffusion rate calculation shall be made on the fifth to the eighth day period and expressed as fluid ounces per square foot per 24 hours. The permeability shall be less than 0.025 fluid ounces per square foot per 24 hours.

NOTE: Diffusion expressed in fluid ounces per square foot per 24 hours equals the gram loss of the test specimen per 24 hours multiplied by a factor K, which is defined as follows:

$$K = \frac{144}{(\text{Sp. gr.}) (29.573) (3.142) (R)^2}$$

Where: Sp. gr. = specific gravity of test fluid at 77° F

R = inside radius of the test cup in inches

4.4.5.3 Seam adhesion. The seam adhesion of the inner layer ply to itself before and after immersion in ASTM D471 Ref Fuel B test fluid, for 72 hours at a temperature of 135° ±3° F (57° ±2° C), shall be tested within 4 hours along the length of the seam by

MIL-DTL-27422D

the strip-back method, using a jaw separation rate of 2 inches per minute in accordance with FED-STD-601, Method 8011 (ASTM D413-76). Where the adhesion of the seam is less than the strength of the material, the adhesion shall be a minimum of 6 pounds per inch. This test is not required for fuel cell constructions that do not employ seams in the inner layer ply.

4.4.5.4 Seam adhesion (alternate procedure). As an alternate procedure to the above, the seam adhesions of the inner layer ply to itself may be tested by cutting a strip of inner layer material 1 inch wide, having a seam made in the same manner as is used in the cells submitted under 4.3. This seam shall be perpendicular to and midway in the length of the strip. When a tensile load has been applied parallel to the length of the strip of sufficient magnitude to break the strip, there shall be no failure of the seam.

4.4.5.5 Slit resistance. A section of the complete fuel cell construction sample shall be selected. A slit of the inner layer ply, 1 inch long to the depth of the sealant, shall be cut parallel to the calendar grain, if present, or to the direction of minimum tear resistance. The test section shall be 5 inches long with width sufficient to clamp in a vise, with the jaws of the vise 1 inch from the slit when the test section is bent 180 degrees. The slit shall be parallel to the vise jaws and on the outside of the bend. The sample shall be held in this folded condition for 1 hour and the increase in length of the slit noted. The slit shall not increase more than 0.25 inch.

4.4.5.6 Inner liner adhesion (Type I fuel cells). The adhesion of the inner layer ply, with barrier when used, to the sealant shall be tested by the strip back method, using a jaw separation rate of 2 inches per minute in accordance with FED-STD-601, Method 8011. The adhesion shall be a minimum of six pounds per inch. For fuel cell constructions that do not employ an inner layer ply, adhesion shall be determined between the inner layer ply and the next adjacent layer.

4.4.5.7 Stress aging. Ten samples of the inner layer ply 4 inches square shall be double folded with the point of double fold located in the center of the sample. The material shall be held in the folded position by means of a spring clip, or equivalent, located 0.5 inch from the double folded edge. Folded samples shall be soaked in ASTM D471 Ref Fuel B test fluid for 7 days at 160° F and air-dried for 7 days at 160° F. There shall be no evidence of blistering, cracking, separation, or other material failure.

4.5 Phase I construction tests.

4.5.1 Constant rate tear. Twenty of the complete fuel cell construction samples in accordance with Figure 4 shall be conditioned at 77° ±5° F and a relative humidity of 50 to 65 percent for 24 hours. At the end of the conditioning period, the samples shall be tested at a jaw separation rate of 20 inches per minute until complete separation occurs. A plot of force versus jaw separation shall be made. The minimum energy for complete separation shall be 400-foot-pound as determined by the area under the force versus jaw separation curve.

MIL-DTL-27422D

4.5.2 Impact penetration. Twenty of the complete fuel cell construction samples in accordance with Figure 5 shall be conditioned at $77^{\circ} \pm 5^{\circ}$ F and a relative humidity of 50 to 65 percent for 24 hours. At the end of the conditioning period, five of the samples shall be impacted from a height of 15 feet with the 5-pound chisel parallel to the warp direction of the exterior ply, five with the chisel at 90° to the warp direction on the exterior ply, five with the chisel at 45° to the right of the warp direction of the exterior ply and five with the chisel at 45° to the left of the warp direction of the exterior ply. All samples shall be impacted on the exterior of the construction. After impact, the interior side of the sample shall be pressurized to 5-psi air. There shall be no evidence of leakage when checked with a soap solution on 18 of the 20 samples tested.

4.5.3 Impact tear. Twenty of the complete fuel cell construction samples in accordance with Figure 6 shall be conditioned at $77^{\circ} \pm 5^{\circ}$ F and a relative humidity of 50 to 65 percent for 24 hours. At the end of the conditioning period, the samples shall be impacted from a height of 10 feet with a 5-pound chisel. The length of tear shall not exceed 0.5 inch on 18 of the 20 samples tested.

4.5.4 Panel strength calibration. Six samples of the complete construction shall be evaluated. Each sample shall be held firmly in a clamping flange as shown on Figure 7, three oriented with the inner liner up and three with the inner liner down. The 4-inch diameter plunger shall be forced into the center of the panel at a rate of 20 inches per minute until failure occurs.

4.5.5 Fitting strength. Four test samples, each containing 4-inch outside diameter fittings shall be fabricated of the complete construction using the same fitting material and attaching methods that will be used on full size production fuel cells. A total weight of 225 ± 5 pounds shall be attached to the fittings as shown on Figure 8. A force transducer shall be located between the fitting and the weight and located as close to the fitting as possible. The test sample shall be attached to a rigid drop cage and dropped from a height of 20 feet and decelerated in a distance of 9 inches or less. Two samples shall be oriented with the inner liner up and two with the inner liner down. The lowest recorded load of the samples tested shall be in excess of 80 percent of the average of the three highest failure loads attained in the panel strength test of 4.5.4, but need not exceed 30,000 pounds, whichever is lower.

4.5.6 Impact resistance. When specified by the Procuring Activity, six test samples (see 4.3.1.1.f) shall be subjected to a test to determine resistance to impact damage (three on the internal surface and three on the external surface). Each test sample shall be installed in a test fixture as shown in Figure 12. The projectile assembly shall weigh between 1 and 1.1 pounds. The projectile assembly shall be dropped from a height of 75 inches for the internal surface test, and 50 inches for the external surface test, and shall impact as shown in Figure 12. The impact area of the specimens shall then be exposed to a 36-inch head of fuel for 15 days. There shall be no evidence of sealant activation at the end of the 15-day period to any of the test samples.

4.5.7 Abrasion resistance. When specified by Procuring Activity, six test samples shall be subjected to a test to determine resistance to abrasion damage (three on the internal surface and three on the external surface). Each test sample shall be installed

MIL-DTL-27422D

in the test fixture as shown in Figure 11. A force of 60 pounds shall be applied at the abrasion chisel, Figure 13. The test sample shall be moved across the abrasion chisel at the rate of two (2) inches per second for a distance of six inches (see Figure 13). The abraded area on the specimen shall then be exposed to a 36-inch head of fuel for 15 days. There shall be no evidence of sealant activation at the end of the 15-day period.

4.5.8 Test Cubes. The Phase I design verification test cubes shall be subjected to the following tests.

4.5.8.1 Fuel resistance test. When specified by the Procuring Activity, the No. 1 test cube shall be filled to capacity after being placed in a container sufficiently large enough to permit immersion of the bottom half of the cube. The cube shall be filled with, and immersed in, one of the test fluids noted in 4.3.2.1 for a period of 60 days at ambient temperature or as specified by the Procuring Activity. After 30 days the test cube shall be carefully examined for any evidence of failure. If no signs of failure are evident, the test cube shall be placed in the container, filled and immersed in the test fluid until the end of the 60-day period. The cube shall then be drained, removed from immersion container and examined. Both the internal and external surfaces of the cube shall show no swelling, separation, blistering, or dissolution, and there shall be no evidence of activation of the sealant material.

4.5.8.2 Crash impact test. The No. 2 test cube with cover plate attached to the fitting and filled with 770 pounds of water (no air in the cube), held loosely with a sling made of webbing similar to Figure 9, or a platform in accordance with Figure 10, shall be lifted to a height of 65 feet measured from the bottom of the cube. With the bottom of the cube in a horizontal position, the cube shall be dropped freely on a non-deforming surface. There shall be no leakage.

4.5.8.3 Slosh resistance test. The No. 1 test cube shall be tested for slosh resistance by mounting on a suitable rocker assembly and rocking the fuel cell through an angle of 15 degrees on each side of the level position (total 30 degrees) at a rate of 18 ± 2 cycles per minute. The fuel cell shall be two-thirds full of ASTM D471 Ref Fuel B test fluid and shall be tested for a period of 25 hours. Class A fuel cells shall be installed in a test structure in accordance with Figure 1. The fluid shall be maintained at a temperature of 110° F throughout the test for Type I fuel cells and 135° F for Type II fuel cells. Brown paper or another leakage detection method shall be used for Type II fuel cells. There shall be no evidence of leakage or failure of any kind during, or as a result, of this test.

4.5.8.4 Gunfire resistance test on test cubes. Class A fuel cells shall be installed in a metal structure as shown on Figure 1. Class B fuel cells shall be tested without auxiliary support. The temperature shall be measured by a thermometer or thermocouple immersed in the fluid. Test cubes shall be mounted 75 feet from the gun. All ammunition shall be standard United States Army stock rounds and shall be fired into the fuel cell space occupied by the fluid a minimum of 6" below the fuel level. A nonmetallic yaw plate or modified gun barrels shall be used to impart tumbling when required by Table III. The firing distance for tumbled rounds can be adjusted to attain

MIL-DTL-27422D

the required tumble, but shall not exceed 75 feet. All rounds shall be fired at service velocity in accordance with MIL-STD-662, Table I.

4.5.8.4.1 Firing schedule. The firing schedule as shown in Table II shall be conducted at low temperature on test cube No. 3. It shall then be repeated at normal temperature on test cube No. 4.

4.5.8.4.2 Low temperature gunfire. As specified by the Procuring Activity, the No. 3 test cube shall be conditioned for gunfire testing by filling three-quarters full of Type I fluid or JP-5 turbine fuel/JP-8 turbine fuel for a period of 24 hours. The fluid used in the conditioning shall remain in the cube during the gunfire test. The conditioning shall be at a temperature of 50° to 100° F. The fuel cell shall then be cooled, and at the time of firing, the temperature of the fluid and fuel cell shall have been maintained at -40° F for a minimum of 4 days.

4.5.8.4.3 Normal temperature gunfire. The No. 4 test cube shall be filled three-quarters full of Type I fluid or JP-5 turbine fuel/JP-8 turbine fuel. The temperature of the fluid at the time of the test shall be 50° to 100° F.

4.5.8.4.4 Gunfire testing. All fuel cells shall be gunfire tested in accordance with 4.5.8.4 and Table II. As specified by the contract or purchase order, one 40 mm highly explosive round, statically detonated 24 inches from the outside of the cell, may be required.

TABLE II. Phase I gunfire schedules.

Round number	Type I, protection level A, and Type II fuel cells	Type I, protection level B	Type I, protection level C and D	Type I, protection level E
1	One .50 caliber projectile 90° to the fuel cell surface and with exit	One .50 caliber projectile 90° to the fuel cell surface into the self-sealing portion of the fuel cell with entrance within 1 inch of transition seam and with exit wherever it occurs	One 14.5 mm AP projectile 90° to the fuel cell surface and with exit	One 14.5 mm AP projectile 90° to the fuel cell surface into the self-sealing portion of the fuel cell with entrance within 1 inch of transition seam and with exit wherever it occurs

MIL-DTL-27422D

TABLE II. Phase I gunfire schedules – Continued.

Round number	Type I, protection level A, and Type II fuel cells	Type I, protection level B	Type I, protection level C and D	Type I, protection level E
2 and 3	One .50 caliber projectile 90° to the fuel cell surface three-quarters to full tumbled entrance	One .50 caliber projectile 90° to the fuel cell surface into the self-sealing portion of the fuel cell with three-quarter to full tumbled entrance	One 14.5 mm AP projectile 90° to the fuel cell surface three-quarters to full tumbled entrance	One 14.5 mm AP projectile 90° to the fuel cell surface into the self-sealing portion of the fuel cell with three-quarter to full tumbled entrance
4	One .50 caliber projectile 45° to the fuel cell surface and with exit	One .50 caliber projectile 45° to the fuel cell surface into self-sealing portion of the fuel cell with exit wherever it occurs	One 14.5 mm AP projectile 45° to the fuel cell surface and with exit	One 14.5 mm AP projectile 45° to the fuel cell surface into self-sealing portion of the fuel cell with exit wherever it occurs
5	One 20 mm AP (M55A1) ^{/1} projectile 90° to the fuel cell surface (not for protection level C)	One 20 mm AP (M55A1) projectile 90° to the fuel cell surface into the self-sealing portion of fuel cell within 3 inches of the transition seam	One 20 mm AP (M55A1) projectile 90° to the fuel cell surface (not for protection level C)	One 20 mm AP (M55A1) projectile 90° to the fuel cell surface into the self-sealing portion of fuel cell within 3 inches of the transition seam
6		One 20 mm AP (M55A1) projectile 90° to the fuel cell surface into non-self-sealing portion of fuel cell within 3 inches of the transition seam		One 20 mm AP (M55A1) projectile 90° to the fuel cell surface into non-self-sealing portion of fuel cell within 3 inches of the transition seam ^{/2}

MIL-DTL-27422D

NOTE ^{/1}: As an alternate to M55A1, a PGU-27/B projectile or other 20 mm projectile may be used as specified by the Procuring Activity.

NOTE ^{/2}: The 20 mm exits to be described in the test report are for information only.

4.5.9 Evaluation following gunfire tests. Following gunfire tests, fuel cells shall be examined to ensure the fuel cells meet the requirements of 3.5.3. When the gunfire wound cannot be seen from the cell exterior, fuel leaking from the cavity drain(s) or from the surrounding structure may be the only way to determine whether or not a wound is leaking.

4.5.9.1 Type I fuel cells. Type I fuel cells shall be examined for the following:

(a) Quantity of fuel leakage

- (1) slow seep (see 6.4(k))
- (2) medium seep (see 6.4(i))
- (3) fast seep (see 6.4(f))
- (4) slow leak (see 6.4(j))
- (5) medium leak (see 6.4(h))
- (6) fast leak (see 6.4(e))

(b) Time required to affect a damp seal (see 6.4(c)). Unless otherwise specified by the Procuring Activity, wounds shall seal within two minutes at ambient temperature and within four minutes at -40° F, if low temperature gunfire is required.

(c) Integrity of inner layer ply, seams, and joints. (Cracking of the inner liner will be permitted under low temperature test of 4.5.8.4.2.)

(d) Integrity of fittings

(e) Deformation of supporting structure

(f) Support for sealant throughout the test

(g) Healing, knitting, or breaching over the gunfire wound

(h) Resistance of non-self-sealing materials to tearing and integrity of transition seam (protection level B).

4.5.9.2 Shots exempt from evaluation. Shots striking as noted below, shall not be considered in verifying the cell performance.

(a) Slicing shots wherein a projectile slices parallel to the fuel cell wall instead of piercing

(b) Striking of fuel cell fittings by the projectile

(c) Shots where the wounds overlap or run together

(d) Shots that strike within 3 inches of test cube corners

(e) Shots where the projectile remains imbedded in the construction

(f) Shots where metallic fingers project into wounds (flowering) and in a mechanical manner prevent the sealant from functioning

(g) Shots where coring is present (see 6.4(b))

4.5.9.3 Type II fuel cells. To ensure Type II fuel cells meet the requirements of 3.5.3, entrance and exit wounds, with the exception of the 20 mm AP exit wounds, shall be examined using the following criteria:

MIL-DTL-27422D

(a) The low temperature gunfire test shall produce no tear longer than 4 inches measured radially from the edge of the wound at each entry and exit point.

(b) The normal temperature gunfire test shall produce no tear longer than 3 inches measured radially from the edge of the wound at each entry and exit point.

(c) All tears not radiating from the bullet hole shall be accounted for by shrapnel or structure.

4.5.10 Aging following gunfire resistance test. After the gunfire resistance test, the cubes shall be emptied and inspected, and any wounds which failed to seal (but did not disqualify the fuel cell) shall be plugged and the fuel cell refilled with ASTM D471 Ref Fuel B test fluid. After 24 hours the fuel cell shall be emptied, and the wounds shall be carefully examined. There shall be no evidence of deterioration of the inner-layer ply or sealant for Type II fuel cells.

4.5.11 Stand test (phase I test cubes). Following the slosh test (see 4.5.8.3) the No. 1 test cube shall be completely filled with ASTM D471 Ref Fuel B test fluid and allowed to stand for 90 days. The fuel cell shall be carefully examined every 30 days for any evidence of failure. For this test, the cube shall be supported in the same manner as for the slosh test. Brown paper or another leakage detection method shall be used for Type II fuel cells.

4.6 Conformance tests.

4.6.1 Phase II product conformance tests. Product conformance test samples shall consist of at least three of each fuel cell to be tested and the supporting structure, or jig, or both, equipped with all applicable fuel cell components. The fuel cells shall be of the same materials and construction as used in the test cubes submitted and approved through the design verification tests. Product conformance verification tests identified in Table III are those tests accomplished on complete full-scale cells or portions thereof.

TABLE III. Product conformance tests.

Test Sample	Test <u>1/</u>	Paragraph
I, II, And III	Inspection test methods	4.6.2.1
I	Installation	4.7.1
	Capacity	4.7.4 (Class B only)
	Pressure	4.7.5
	Slosh or slosh and vibration resistance	4.7.6
	Aging and low temperature leakage	4.7.9
	Dissection	4.7.10

MIL-DTL-27422D

TABLE III. Product conformance tests – Continued.

Test Sample	Test <u>1/</u>	Paragraph
II	Accelerated load resistance <u>2/</u>	4.7.11
	Gunfire resistance on cell installation	4.7.12
III	Crash impact test on full sized design verification test fuel cells	4.7.18

NOTE: 1/ Test on each sample should be conducted in the order listed above.
2/ An additional sample may be used for this test.

4.6.2 Types of product conformance tests. Product conformance testing shall consist of:

- (a) Inspection test methods (4.6.2.1)
- (b) Sampling tests (4.6.3)

4.6.2.1 Inspection test methods.

4.6.2.1.1 Examination. Each fuel cell shall be carefully examined to determine conformance to all the requirements of this specification for which no specific tests are described and to determine conformance with approved manufacturer's (see 6.4(g)) material, fabrication, and inspection specification, and applicable drawings.

4.6.2.1.2 Dimensional. A check shall be made on each fuel cell to insure that all dimensions critical to the installation are within the dimensional tolerances established by the Procuring Activity. The fuel cell tolerances specified for this test shall not conflict with the capacity requirements specified in 3.3.3.

4.6.2.1.3 Weight. The weight of each finished cell shall be checked to determine compliance with 3.5.5.

4.6.2.1.4 Workmanship. Each fuel cell shall be inspected to determine that the workmanship meets the requirements given in 3.8.

4.6.3 Sampling tests. The samples specified in paragraphs 4.6.3.2, 4.6.3.3, and 4.6.3.4 shall be selected from fuel cells produced at a particular plant for a specific aircraft and approved under the same verification test and identified with the manufacturer's (see 6.4(g)) same construction number. The random samples selected shall be representative of fuel cells submitted by the manufacturer for acceptance with respect to quality of workmanship and the number and type of repairs.

MIL-DTL-27422D

4.6.3.1 Capacity check samples (Class B cells only). Each of the first 10 production fuel cells shall be checked for capacity in accordance with 4.7.4. An average fuel level versus volume curve shall be constructed from these tests. Material tests may be conducted in any order. Tests on each individual test cell shall be conducted in the order listed.

4.6.3.2 Stand test samples. As required by the Procuring Activity, fuel cells selected at random shall be subjected to the stand test described in 4.3.3. The following schedule shall be used as guidance to establish sampling requirements.

<u>Number of samples</u>	<u>Number of units produced</u>
1	1-50
1	1 every 90 days or 1 out of each additional 500 fuel cells, whichever occurs first

4.6.3.3 Dissection test samples. As required by the Procuring Activity, fuel cells selected at random shall be dissected as shown in Figure 2, and subjected to the dissection test of 4.3.4. The following schedule shall be used as guidance to establish sampling requirements.

<u>Number of samples</u>	<u>Number of units produced</u>
2	1-50
1	1 out of each additional 90 days' production or 1 out of each additional 50 units produced, whichever occurs latest. However, the maximum time between tests shall not exceed 180 days.

4.6.3.4 Crash impact test samples. As required by the Procuring Activity, fuel cells selected at random shall be subjected to the crash impact tests described in 4.7.18.

<u>Number of samples</u>	<u>Number of units produced</u>
1	Every 250 th fuel cell produced or
1	Every 365 days, whichever comes first.

MIL-DTL-27422D

4.7 Phase II tests.

4.7.1 Installation. For this test, the aircraft, or a section thereof, or a fixture described in 4.7.2 shall be used. The installation test shall be performed prior to the pressure test described in 4.7.5. The installation test shall consist of removing and installing the cell in the test structure three times. Applicable servicing procedures shall be followed in cell installation and removal. All cell fittings shall be fastened to corresponding structure fittings and interconnect fittings of each installation. The cell shall be in a satisfactory condition on the completion of this test.

4.7.2 Tank mounting structure. As required by the Procuring Activity, the fuel cell shall be tested in a manufacturer-constructed tank mounting structure that simulates the shape, dimensions, and material of the cell supporting structure in the aircraft, including the necessary stops, cushions, pads, and hangers. The test cell shall be mounted in the test structure in a manner that duplicates the actual installation. In addition, all lines attached to the cell in the actual installation shall be included in this structure. The length and configuration of these lines shall be the same as the actual installation.

4.7.3 Cell support fixture. The support fixture, if required, shall be suitable for carrying the mounted sample cell and designed for bolting to the vibrator and rocker assembly. The fixture framework shall be sufficiently rigid to prevent the possibility of unrealistic stresses being imposed on the mounted cell.

4.7.4 Capacity (Class B cells only). The fuel cell, supported in the same manner as in the aircraft, shall be filled to capacity with ASTM D471 Ref Fuel B test fluid, or as specified by the Procuring Activity. The volume in gallons and the fuel level in inches shall be recorded at a sufficient number of points during the filling to construct a fuel level versus volume curve.

4.7.5 Pressure. For this test, the cell shall be mounted in the product verification slosh test structure (see 4.7.2). All openings in the cell shall be sealed during the pressure test. Cells shall be subjected to a pressure equivalent to the normal fuel level measured at the bottom of the cell multiplied by a factor of 1.5. The fuel cells shall be pressure tested for 15 minutes. No change in pressure shall occur.

4.7.6 Slosh or slosh and vibration resistance. For this test, an actual section of the aircraft structure or a structure that simulates the shape, dimensions, and material to the tank supporting structure in the aircraft shall be secured to the fixture described in 4.7.3. As specified by the Procuring Activity, internal plumbing and components shall be installed. All fitting and non-self-sealing areas in the interior of each fuel cell compartment shall be lined with brown paper held in place with a suitable adhesive. The test specimen shall be slosh or slosh and vibration tested (see 4.7.7 and 4.7.8) with the tank two-thirds full of ASTM D471 Ref Fuel B test fluid containing a staining agent at a temperature of 110° F for Type I fuel cells and 13° F for Type II fuel cells. All slosh or slosh and vibration resistance tests shall be conducted with the cell subjected to a pressure equivalent to the maximum stabilized vapor pressure encountered in any prescribed stabilized level flight conditions. The cell shall be mounted in such a manner

MIL-DTL-27422D

as to simulate pitching in the actual aircraft. Special fixtures, such as baffles, shall also be tested, if applicable, by mounting the aircraft structure on the rocker in another position for a portion of the test time. The pressure test (see 4.7.5) shall be repeated. There shall be no evidence of leakage or failure of the fuel cell or the attachment of its components during this test.

4.7.7 Rotorcraft or tilt rotorcraft. Tests of rotorcraft and tilt rotorcraft cells, shall be conducted on a manufacturer-proposed/Procuring Activity-approved vibration and rocker assembly and shall conform to the following requirements:

(a) Class A cells or portions thereof, except those with fuel tanks containing suspension or supporting arrangements which may be subject to failure due to vibration shall be slosh tested.

Test conditions:

Time: 40 hours

Rock: Total of 30°, approximately 15° on either side of the horizontal position

Cycles per minute: 10 to 20

(b) Class A cells or portions thereof, with fuel tanks containing supporting or suspension arrangements which may be subject to failure due to vibration, and Class B cells shall be slosh and vibration tested.

Test conditions:

Time: 25 hours simultaneous slosh and vibration and 15 hours additional slosh

Rock: Total 30°, approximately 15° on either side of the horizontal position

Cycles per minute: 10 to 20

Displacement: The throw of the two eccentric weights on the vibration machine shall be in the same direction and shall be adjusted to produce a total displacement of 0.032 inch, +0.010 inch, -0.000 inch measured at points of inherent rigidity on the tank.

Speed: Tanks for piston-powered aircraft shall be 90 percent of normal rated crankshaft speed and tanks for turbine-powered aircraft shall be 2,000 ±100 rpm.

(c) Remove fuel cell from structure and examine for evidence of damage or failure.

4.7.8 Alternate vibration frequency and displacement. Where the above frequencies and displacements are not applicable, the cell shall be vibrated at a frequency and displacement agreed upon by the contractor (see 6.4(a)) and the Procuring Activity.

4.7.9 Aging and low temperature leakage. As required by the Procuring Activity, the cell shall be mounted in a structure for which it is designed, or a simulated test sample incorporating identical cell fitting installations may be used. The interior of the test structure around fitting areas shall be lined with brown paper or other suitable means for detecting leakage. The cell with fittings assembled shall be subjected to a 7-day soak with ASTM D471 Ref Fuel B test fluid at a fluid temperature of 135° F. Following the hot fuel soak, the cell shall be emptied and air-dried for a period of 7 days at a temperature of 160° F. On completion of the 7-day period of air-drying, the cell shall be filled with

MIL-DTL-27422D

JP-5, JP-8, or ASTM D471 Ref Fuel A test fluid containing a staining agent and placed in a cold box for a period of 3 days. The cold box shall be maintained at a temperature of -65° F for the 3-day period. At the end of this 3-day period, the cell shall be removed from the cold box, drained, and examined for any indications of leakage. The cell shall then be filled with ASTM D471 Ref Fuel A test fluid containing a staining agent and allowed to stand at ambient temperature for a period of 80 days. At the end of the 80 days, the fluid shall be drained and the cell examined for any unsatisfactory condition or indication of fuel leakage or activation of the cell sealant (Type I cells). Any repeat testing of the fuel cell for aging and low temperature leakage may be simulated in other than a full-scale cell.

4.7.10 Dissection. After completion of the test described in 4.7.9, the fuel cell shall be dissected as shown on Figure 2. The sectioned portion of each fuel cell shall be examined. MIL-STD-801 may be used as a guide.

4.7.11 Accelerated load. As requested by the Procuring Activity, the tank assembly shall be mounted in a test jig that provides support equivalent to the aircraft structure for which it is designed and subjected to a load test as mutually agreed upon between the fuel cell manufacturer (see 6.4(g)) and the Procuring Activity. Unless otherwise specified by the Procuring Activity, all tank assembly components shall be installed during the test. This test shall be conducted to determine the suitability of the cell installation under aircraft design accelerations, including the appropriate dynamic magnification factors. The tank shall be filled to operational capacity as determined in 4.7.4 with JP-5, JP-8, or ASTM D471 Ref Fuel A test fluid at a fluid temperature of 50° to 100° F. Tanks of pressurized systems shall be subjected to normal operating pressures during this test, except where unpressurized conditions are considered to be more critical. There shall be no structural failure of any components of the tank during this test. When measured, deflection of the cell shall not interfere with the functional operation of the aircraft components. All tanks shall be tested dynamically.

4.7.12 Gunfire resistance test on cell installation (Type I and II). For this test, the cell shall be mounted in an actual section of the aircraft structure containing the backing board that will be used in the specific application. The cell for this test need not include accessories. The cell shall be filled two-thirds full with JP-5, JP-8, or ASTM D471 Ref Fuel A test fluid. All gunfire testing shall be conducted with the cell subjected to an internal pressure equivalent to the maximum stabilized vapor pressure encountered during any prescribed stabilized level flight conditions. The cell shall be subjected to the gunfire test in accordance with the capacity of each cell. The number of rounds of .50 caliber AP ammunition to be fired shall be determined on the basis of one round for each 15 gallons of cell capacity up to a maximum of 10 rounds. All shots shall simulate the aircraft installation and the combat utility of the aircraft. Unless otherwise specified by the Procuring Activity, all shots shall be at least six inches below the fluid level, and the distribution of shots in elevation shall encompass the minimum to maximum fuel level. Tumbled .50 caliber AP rounds shall be utilized to simulate shrapnel. No bursts shall be fired, and the test shall be conducted at ambient temperature. All rounds shall be fired at service velocity IAW MIL-STD-662, Table I. The same conditions that are cause for rejection of the phase I test fuel cell shall apply to this test.

MIL-DTL-27422D

4.7.13 Type I, Protection level A and B test. In addition to the .50 caliber gunfire, one round of 20 mm AP ammunition (M55A1) or PGU-27/B projectile shall be fired into the self-sealing portion of the fuel cell. A seal is required for the entrance wound only.

4.7.14 Type I, Protection level B and E test. At least two rounds of .50 caliber shall be fired into the non-self-sealing portion of the fuel cell.

4.7.15 Type I, Protection level C, D, and E test. The 14.5 mm AP rounds will be counted in the total number of rounds required. Four of the rounds shall be 14.5 mm AP, of which two rounds shall be three-quarter to full tumbled and two be unyawed, all to be fired at 0 degrees obliquity to the fuel cell surface.

4.7.16 Type I, Protection level D test. In addition to the 14.5 mm AP rounds, one round of 20 mm AP ammunition (M55A1) or PGU-27/B projectile shall be fired. A seal is required for the entrance wound only.

4.7.17 Type I, Protection level E test. In addition to the 14.5 mm AP rounds, two rounds of 20 mm AP ammunition (M55A1) or PGU-27/B projectiles shall be fired; one into the self-sealing portion of the fuel cell and one into the non-self-sealing portion of the fuel cell. A seal is required for the entrance wound only.

4.7.18 Full-sized product crash impact test. Each full-sized fuel cell shall be tested using a fixture as described in Figure 10.

4.7.19 Drop test with rotary wing type aircraft. The fuel cell, with all openings suitably closed, shall be filled to normal capacity with water and the air removed. The fuel cell shall then be placed upon the platform and raised to a height of 65 feet, measured from the bottom of the fuel cell. The platform shall be released and allowed to drop freely onto a non-deforming surface so that the fuel cell shall impact in a horizontal position $\pm 10^\circ$. After the drop test there shall be no leakage. A lightweight cord or other lightweight device acceptable to the Procuring Activity may be used to support the fuel cell in its proper attitude.

5. PACKAGING.

5.1 Packaging. For acquisition purposes, the packaging requirements shall be as specified in the contract or order. When actual packaging of materiel is to be performed by DoD personnel, these personnel need to contact the responsible packaging activity to ascertain requisite packaging requirements. Packaging requirements are maintained by the Inventory Control Point's packaging activity within the Military Department or Defense Agency, or within the Military Department's System Command. Packaging data retrieval is available from the managing Military Department's or Defense Agency's automated packaging files, CD-ROM products, or by contacting the responsible packaging activity.

MIL-DTL-27422D

6. NOTES

(This section contains information of a general or explanatory nature that may be helpful, but is not mandatory.)

6.1 Intended use. Self-sealing and non-self-sealing fuel cells manufactured under this specification are intended for use in rotorcraft and tilt rotorcraft as a means for carrying aircraft fuel (including aromatic constituents) under all prescribed operating conditions. Additionally, fuel cells manufactured under this specification will be used to prevent, under the gunfire conditions specified herein, an excessive loss of fuel and provide a significant reduction in post crash fires. (It is desired that the service life of a fuel cell covered by this specification be equivalent to that of the aircraft life in which they are installed.)

6.2 Acquisition requirements. Acquisition documents must specify the following:

(a) Title, number, and date of the specification.

(b). Issue of DoDISS to be cited in the solicitation, and if required, the specific issue of individual documents referenced (see 2.2.1).

(c) Packaging requirements (see 5.1).

6.3 Government inspections. The Government reserves the right to perform any of the inspections set forth in section 4 of this specification where such inspections are deemed necessary to assure supplies and services conform to prescribed requirements.

6.4 Definitions.

(a) Contractor. The term contractor refers to the airframe manufacturer. (see 3.2)

(b) Coring. Core shots are strikes, which result in removal of fuel cell wall material outside a circle with a diameter that is 10 percent greater than the diameter of the projectile. (see 4.5.9.2.g)

(c) Damp seal. Evidence of fluid surrounding the hole, but no accumulation. (see 3.5.3.1.1.1)

(d) Dry seal. No visible fluid surrounding the hole. (see 3.5.3.1.1.1)

(e) Fast leak. Fluid escapes with sufficient force to separate from fuel cell wall; stream is greater than one-quarter inch in diameter. (see 4.5.9.1(a)(6))

(f) Fast seep. Fluid escapes through the hole at a significant rate and flows in contact with the fuel cell wall. (see 4.5.9.1(a)(3))

MIL-DTL-27422D

(g) Manufacturer. For purposes of this specification, the term manufacturer refers to the manufacturer of the fuel cells. (see 3.9)

(h) Medium leak. Fluid escapes with sufficient force to separate from the fuel cell wall; stream is greater than one-eighth inch, but less than one-quarter inch in diameter. (see 4.5.9.1(a)(5))

(i) Medium seep. Fluid escapes through the hole at an easily discernable rate and flows in contact with the fuel cell wall. (see 4.5.9.1(a)(2))

(j) Slow leak. Fluid escapes with sufficient force to separate from the fuel cell wall; stream is less than one-eighth inch in diameter. (see 4.5.9.1(a)(4))

(k) Slow seep. Fluid escapes through the hole at a barely discernable rate and flows in contact with the fuel cell wall. (see 4.5.9.1(a)(1))

6.5 Failure due to coring. A failure due to coring of the cell will not be cause for rejection, except that coring on any type of shot (i.e., tumbling oblique entry or straight entry) will not exceed 20 percent of the total number of rounds fired for the particular type test. If coring is present, the extent of such coring will be quantitatively described as a percentage of the projectile diameter.

6.6 Subject term (key word) listing.

Cell
Flexible
Non self-sealing
Self-sealing
Semi-rigid

6.7 Changes from previous issue. This specification was revised to change the cited reference MIL-HDBK-806 (which was canceled) to MIL-STD-801 and to ensure the format and content meet the requirements of MIL-STD-961E.

MIL-DTL-27422D

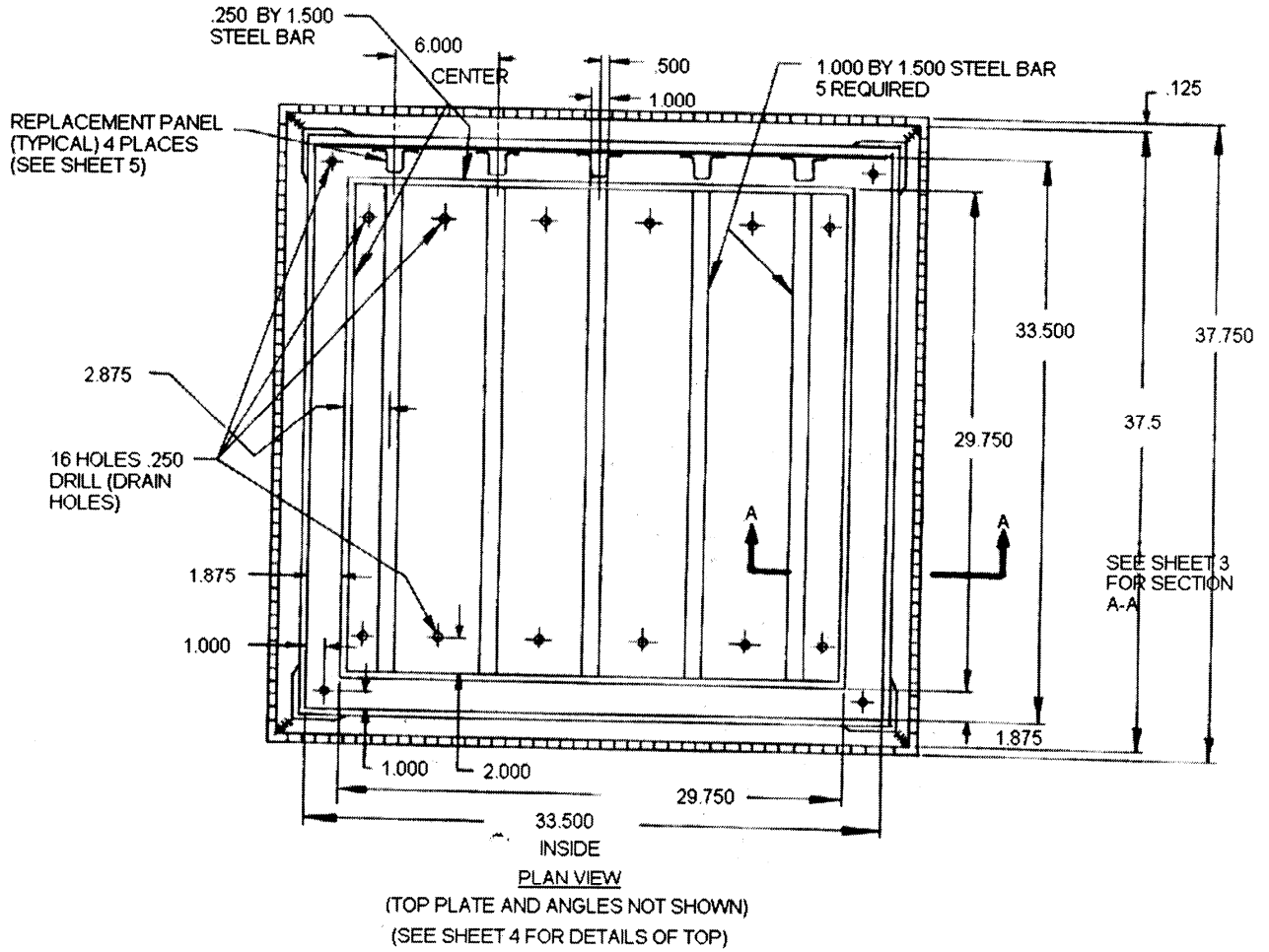

DIMENSIONS IN INCHES. TOLERANCES: DECIMALS +/- .016.

FIGURE 1. Mounting structure for Phase I verification test.

Sheet 1 of 5

MIL-DTL-27422D

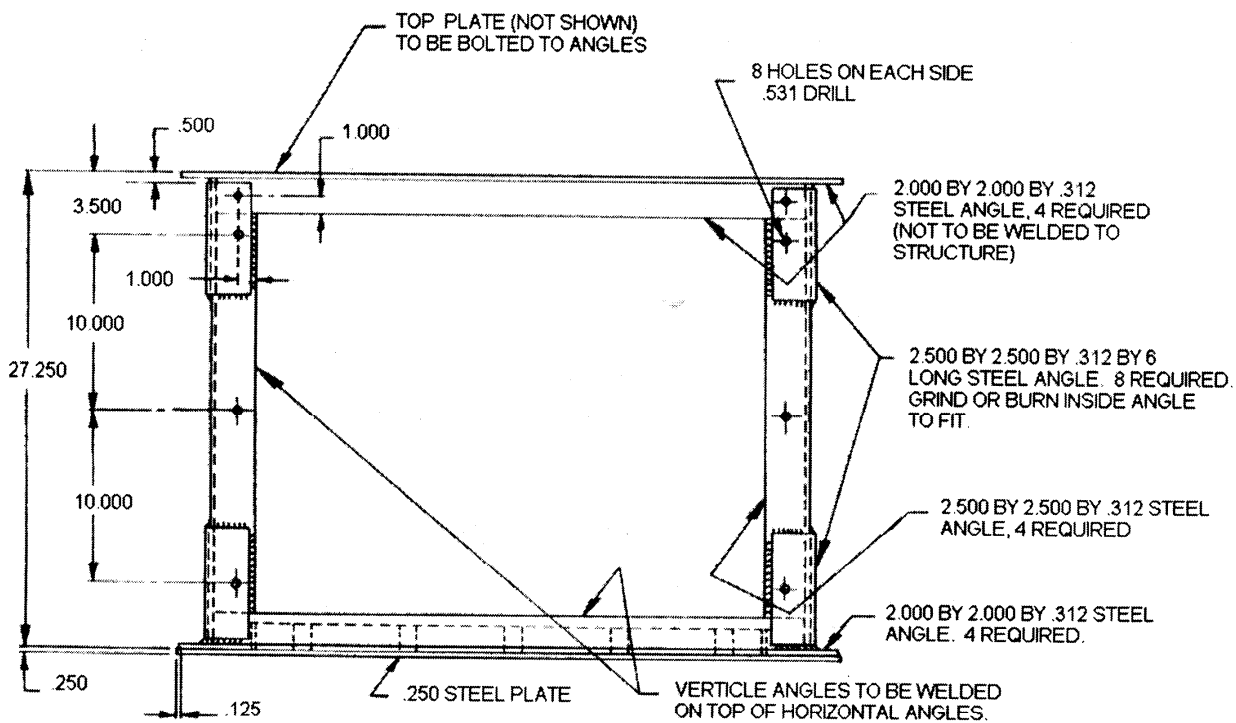

DIMENSIONS IN INCHES, TOLERANCES: DECIMALS +/- .016.

FIGURE 1 (continued). Mounting structure for Phase I verification test.

Sheet 2 of 5

MIL-DTL-27422D

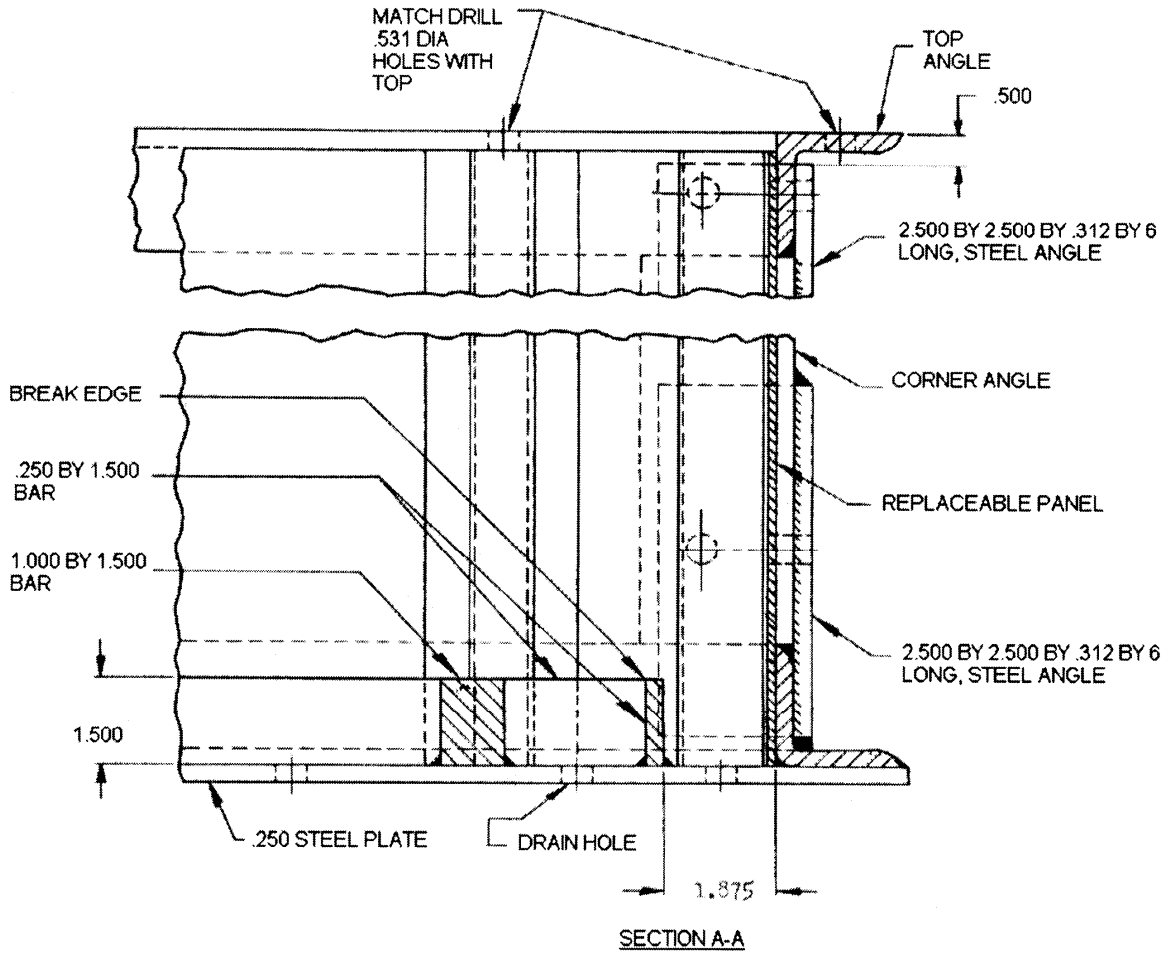

DIMENSIONS IN INCHES. TOLERANCES: DECIMALS +/- .016.

FIGURE 1(continued). Mounting structure for Phase I verification test.

MIL-DTL-27422D

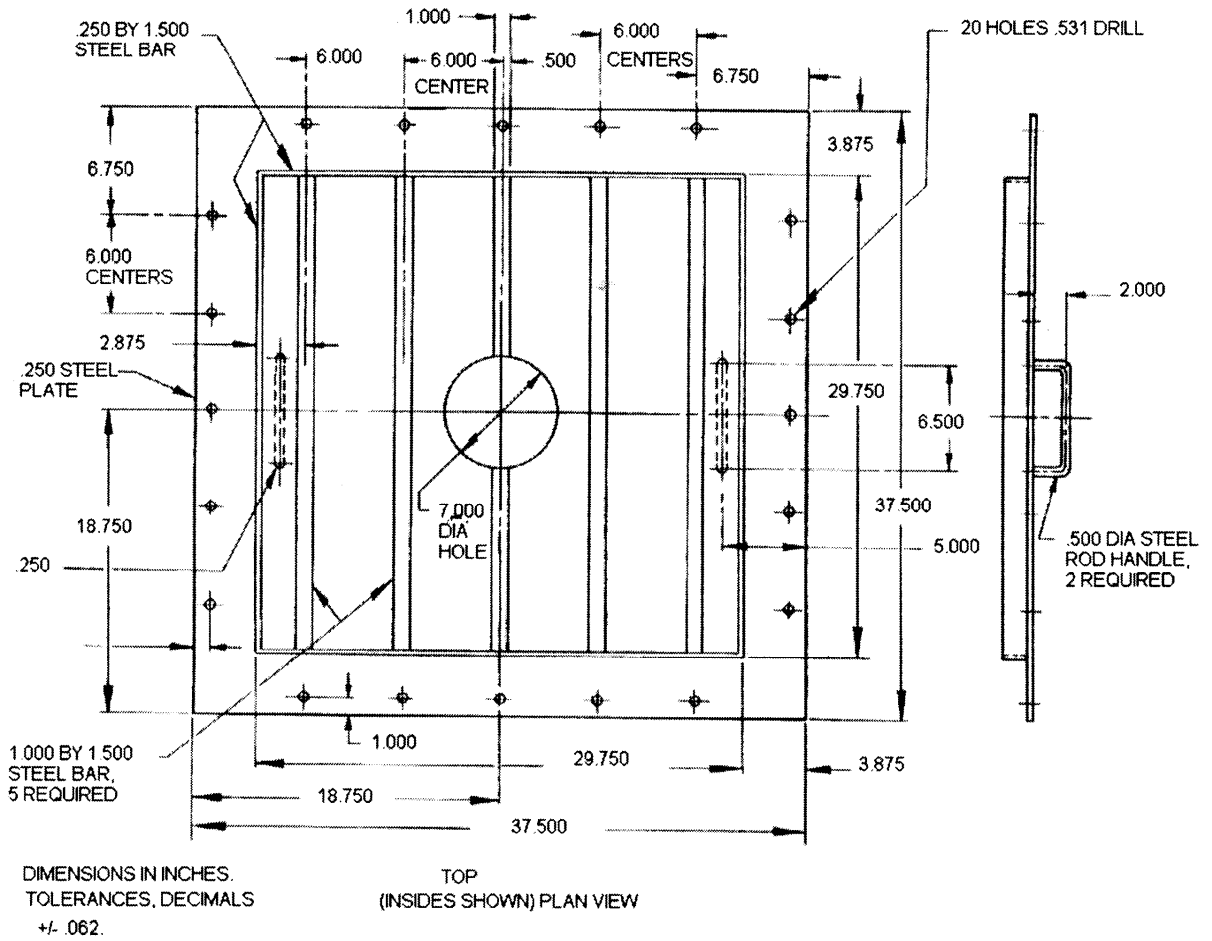
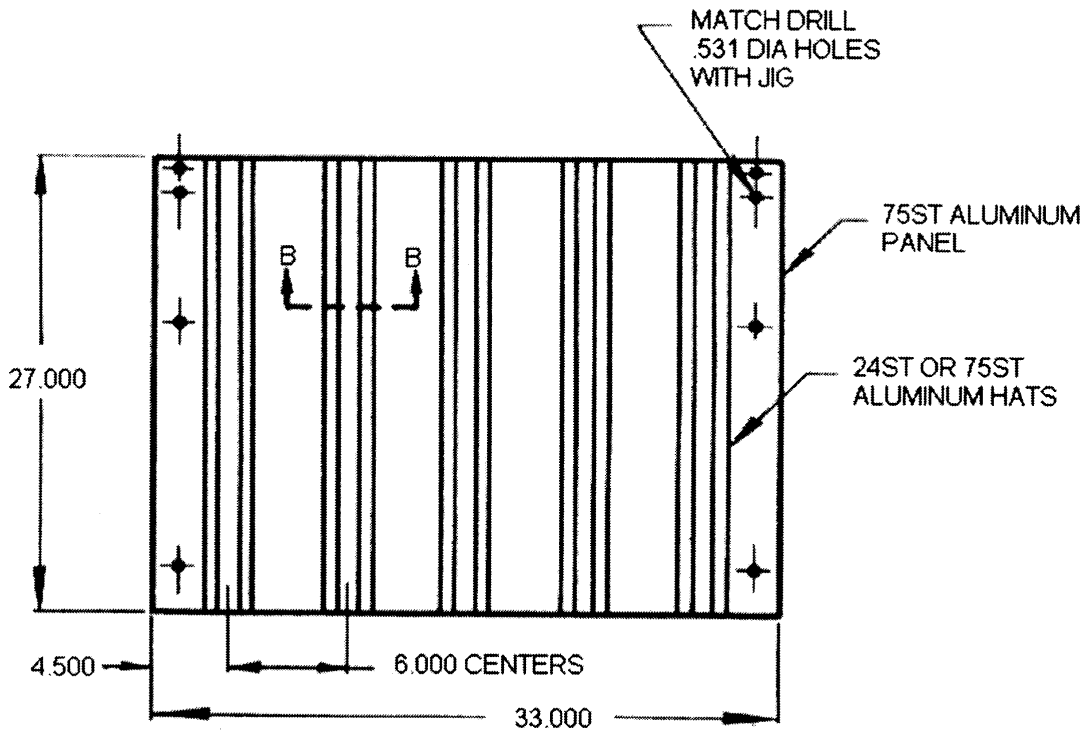
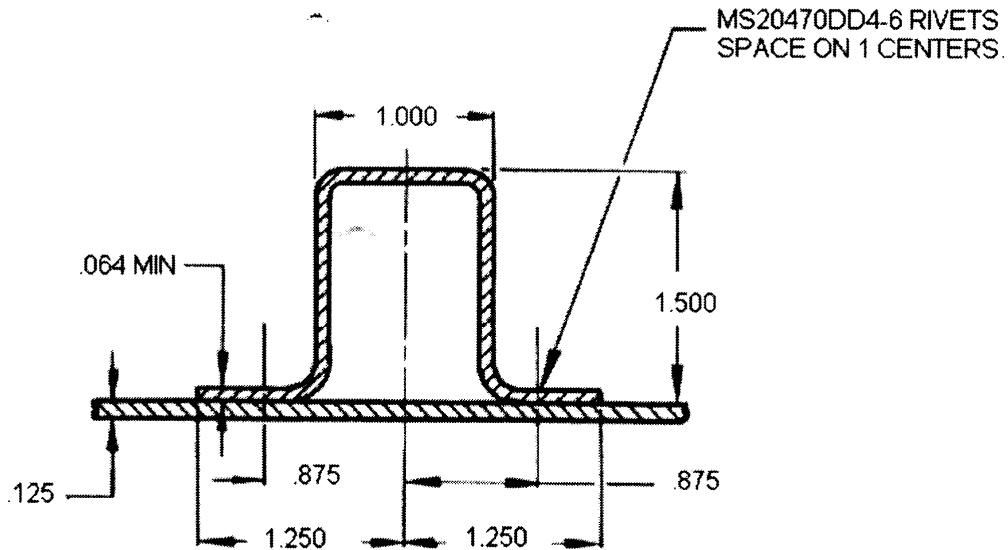

FIGURE 1(continued). Mounting structure for Phase I verification test.

MIL-DTL-27422D



REPLACEABLE PANEL -- 4 REQUIRED PER STRUCTURE



SECTION B-B

DIMENSIONS IN INCHES. TOLERANCES: DECIMALS +/- .062.

FIGURE 1(continued). Mounting structure for Phase I verification test.

MIL-DTL-27422D

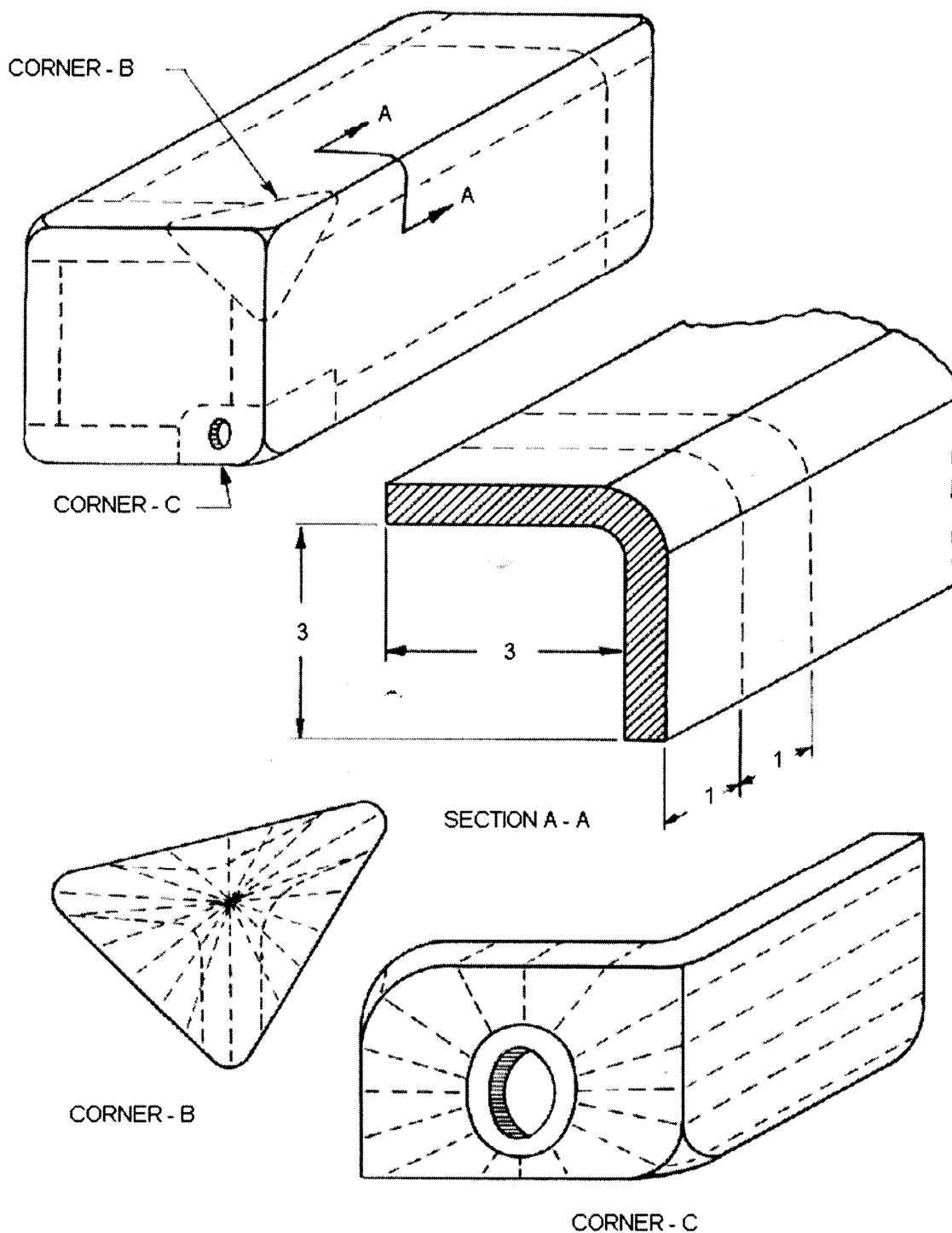

DIMENSIONS IN INCHES
CUT ON DOTTED LINES

FIGURE 2. Location of cuts for dissection sample.

MIL-DTL-27422D

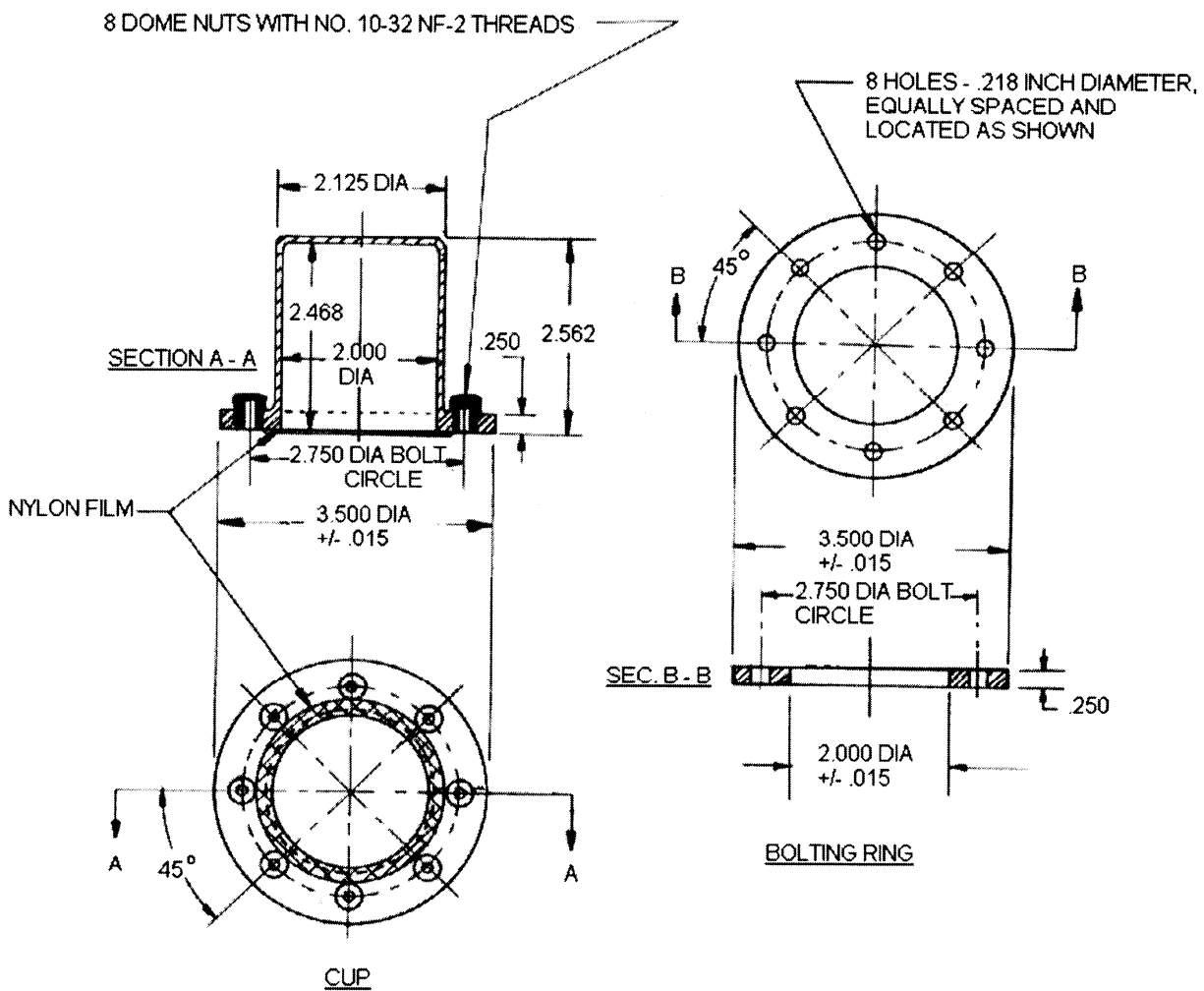

BREAK ALL EDGES .031 RAD, MAX
ALL FILLETS .031 RAD, MAX

MATERIAL: 17ST ALUMINUM ALLOY BAR STOCK OR EQUAL

DIMENSIONS IN INCHES. UNLESS OTHERWISE SPECIFIED, TOLERANCES: +/- .010

FIGURE 3. Cup for permeability test.

MIL-DTL-27422D

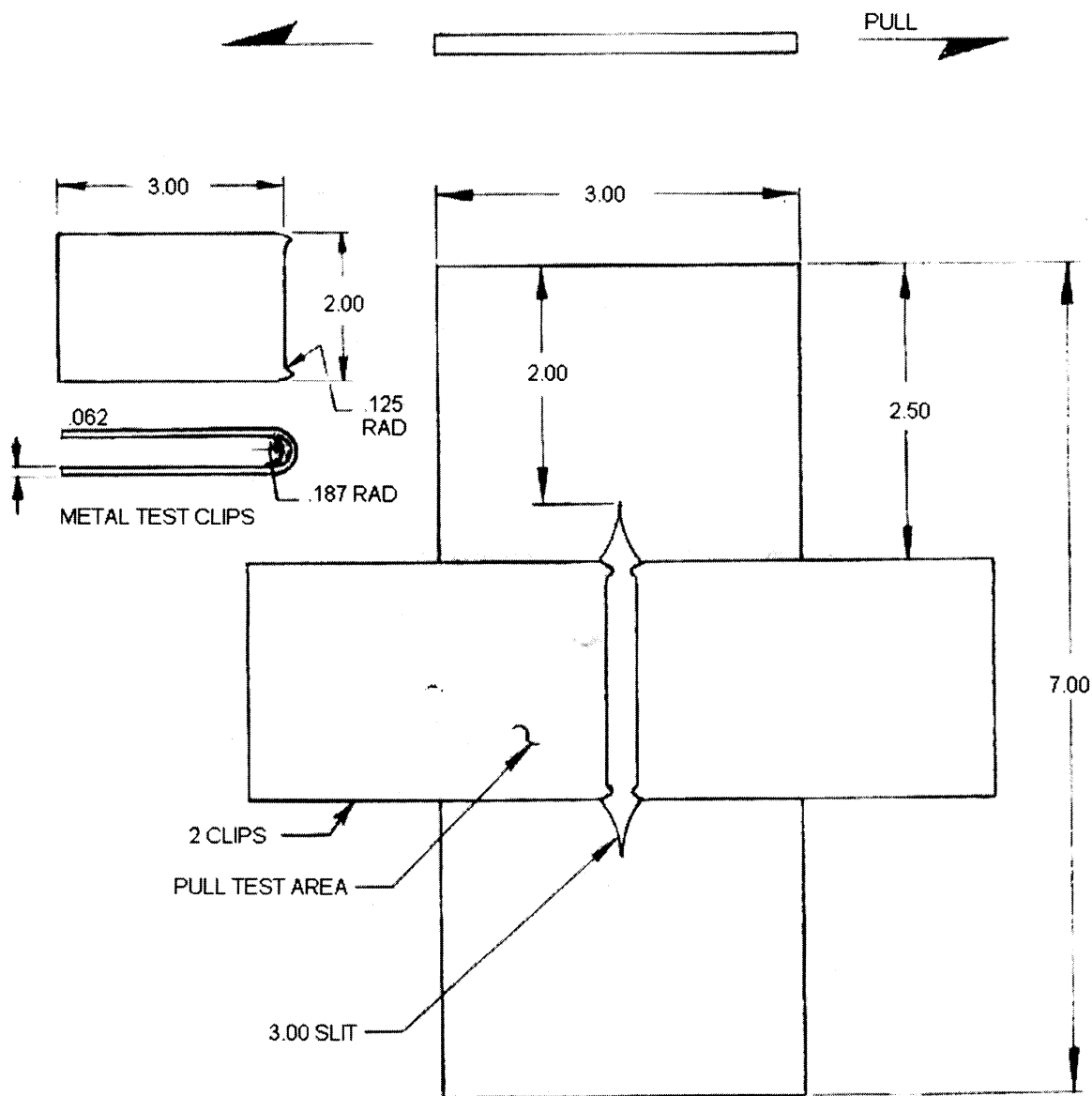

SAMPLES SHALL BE CUT IN ACCORDANCE WITH 4.3.1.1 (e) ✓

DIMENSIONS IN INCHES. UNLESS OTHERWISE SPECIFIED, TOLERANCES: $\pm .032$

FIGURE 4. Constant rate tear test sample.

MIL-DTL-27422D

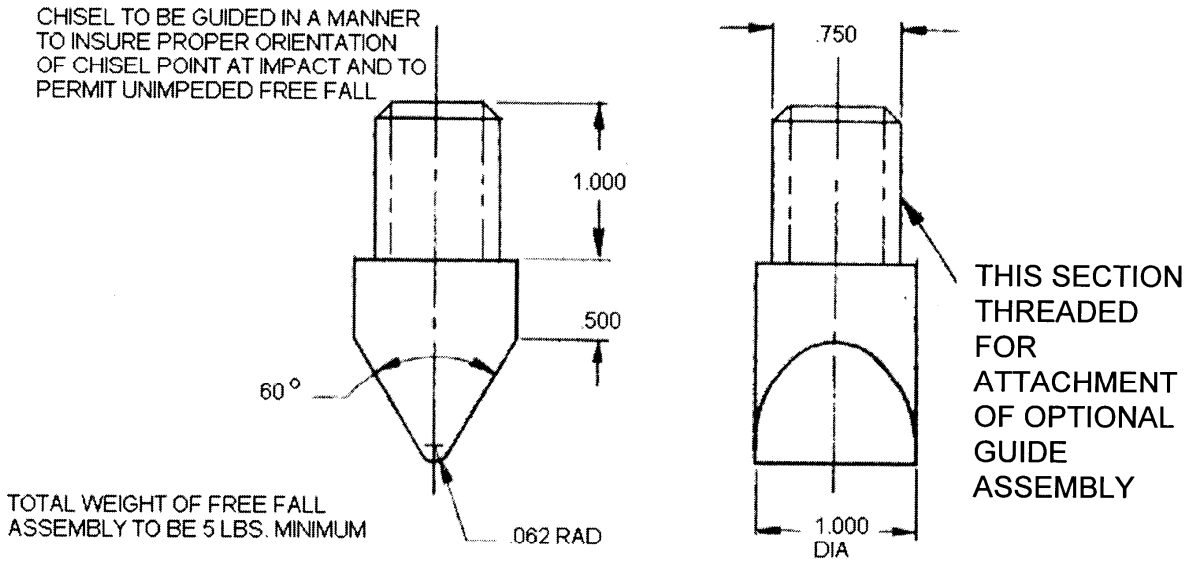

TEST SAMPLE SIZE 10.000 DIAMETER
8 - .750 HOLES EQUALLY SPACED ON 7.50 B.C.

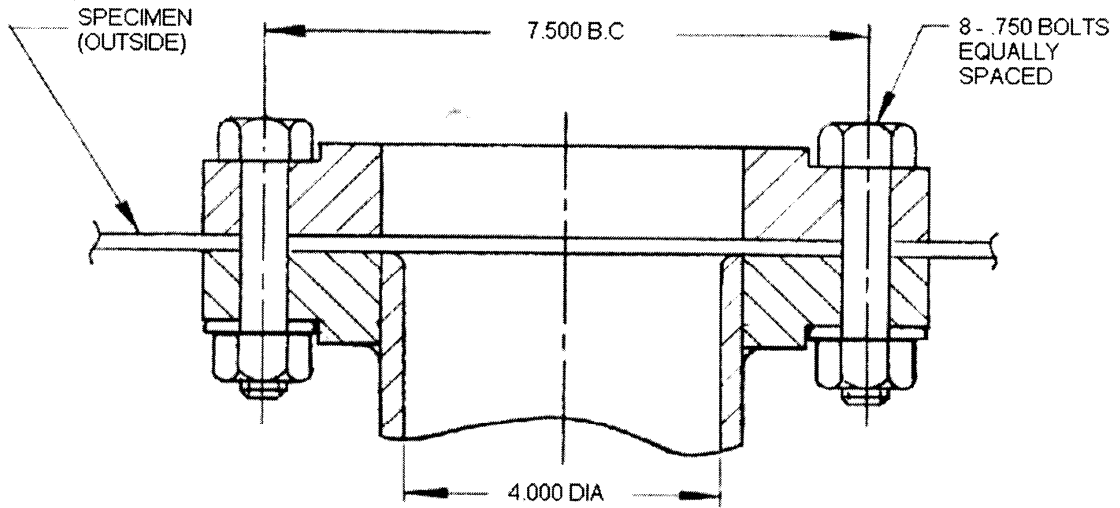

MATERIAL: CARBON STEEL
DIMENSIONS IN INCHES. UNLESS OTHERWISE SPECIFIED, TOLERANCES +/- .016

FIGURE 5. Impact penetration test.

MIL-DTL-27422D

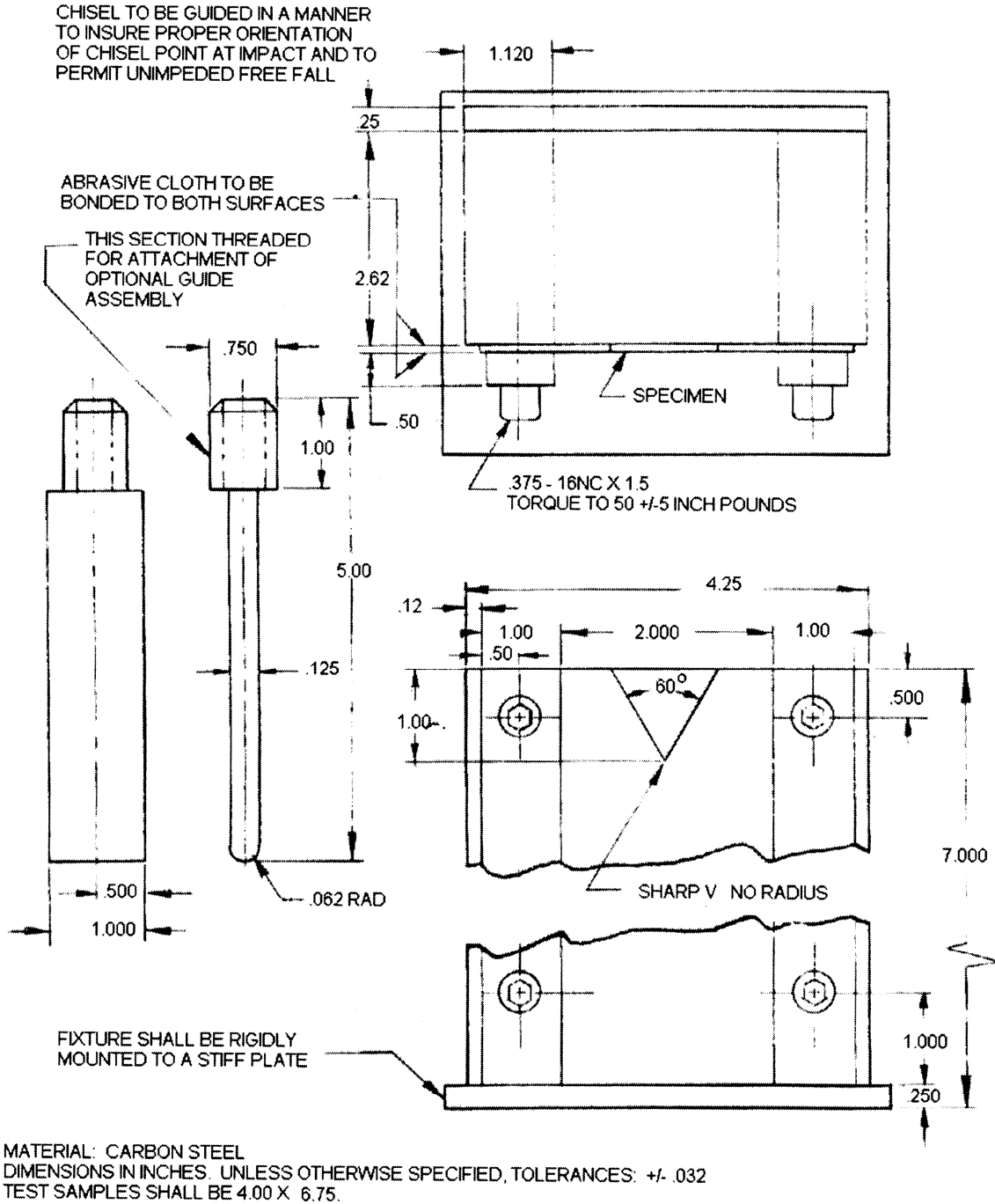
FIGURE 6. Impact tear test.

MIL-DTL-27422D

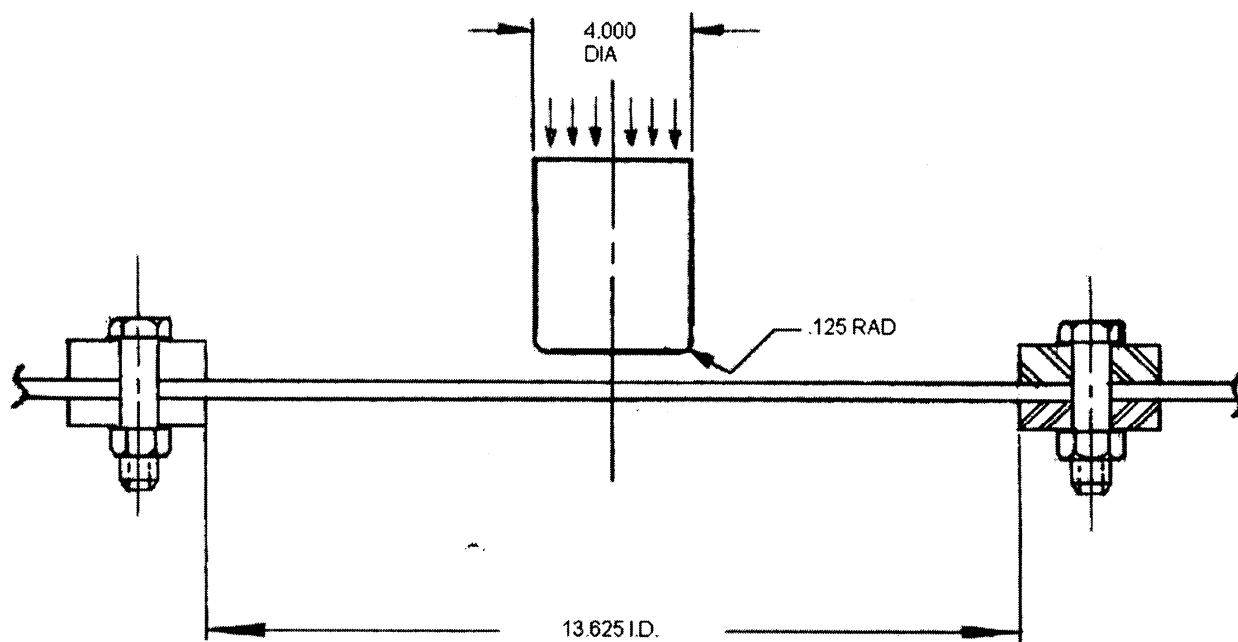

THE CLAMPING RING SHALL BE DESIGNED SO THAT SAMPLING FAILURE DOES NOT OCCUR AT THE CLAMPING RING.

MINIMUM TEST SAMPLE SIZE 16.75 DIAMETER

DIMENSION IN INCHES. UNLESS OTHERWISE SPECIFIED, TOLERANCES: +/- .032

FIGURE 7. Panel strength test.

MIL-DTL-27422D

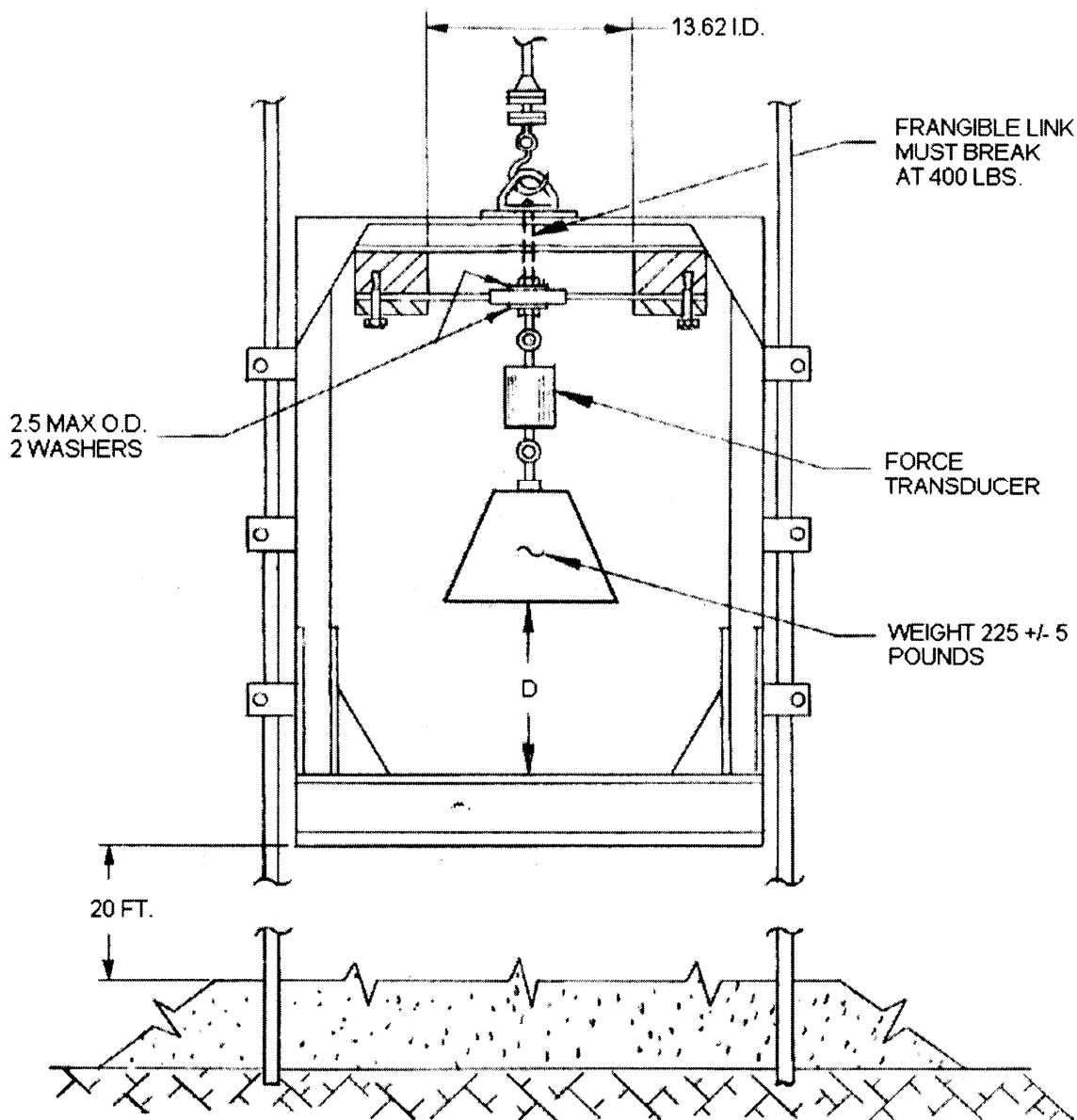

D - THIS DISTANCE SHALL BE SUFFICIENT TO PREVENT BOTTOMING OUT PRIOR TO FITTING PULLOUT

MINIMUM SIZE OF TEST SAMPLE 21.50 DIAMETER

DIMENSIONS IN INCHES.

FIGURE 8. Fitting pull out test setup.

MIL-DTL-27422D

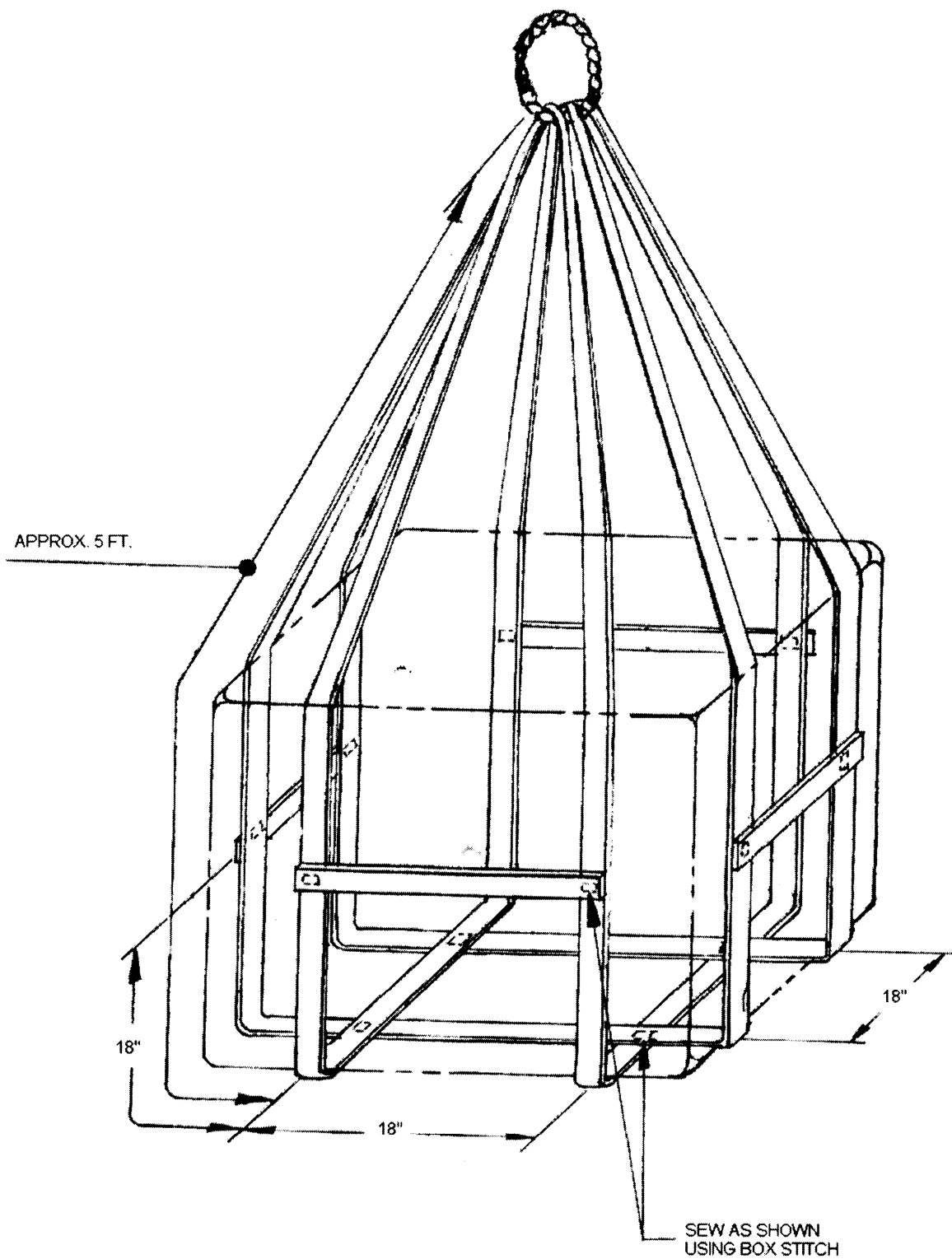
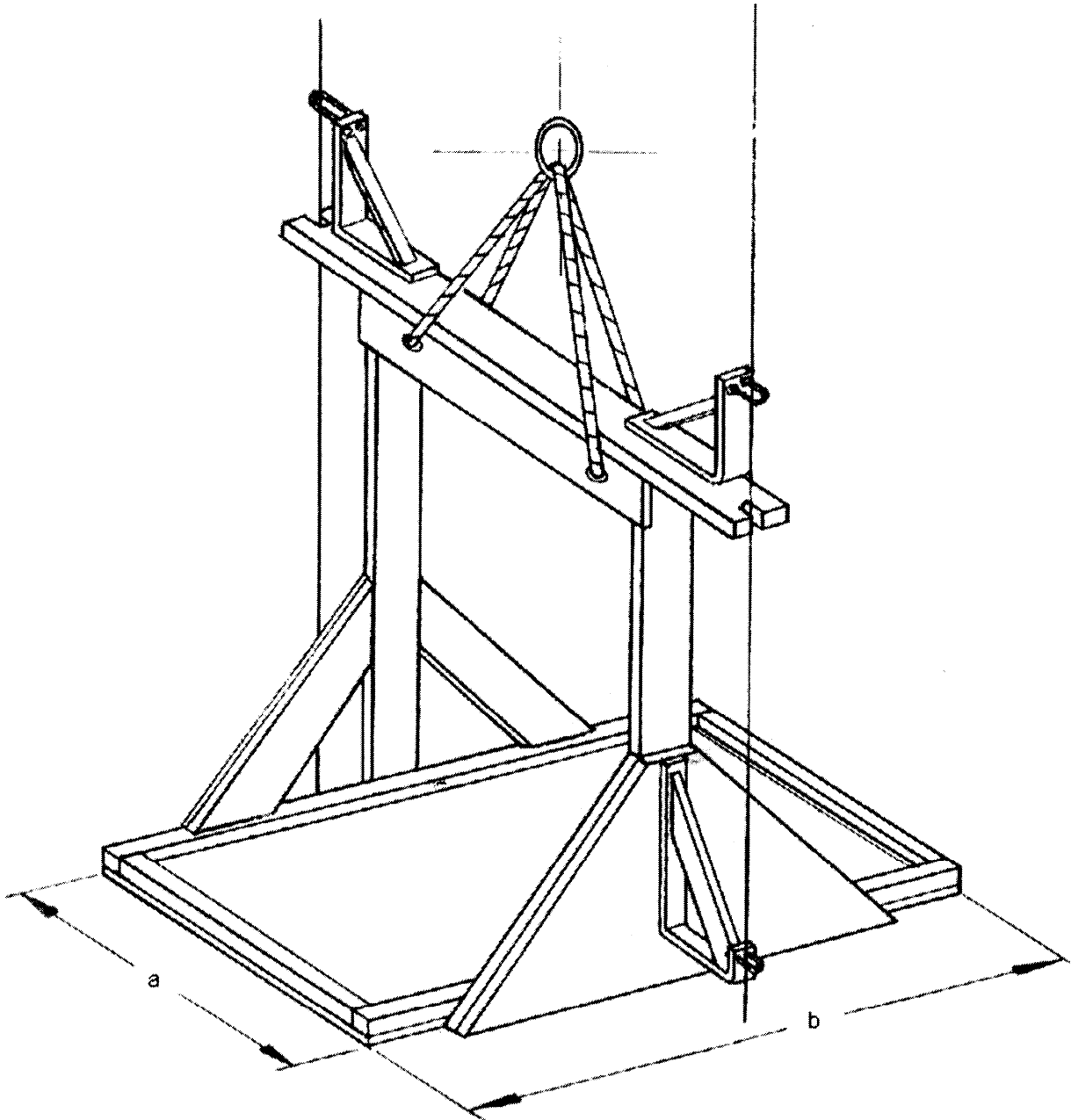

FIGURE 9. Phase I impact test sling.

MIL-DTL-27422D



DIMENSIONS a AND b SHALL NOT EXCEED CELL DIMENSIONS (WHEN THE LOADED CELL IS IN PLACE FOR TEST) BY MORE THAN 12 INCHES IN EITHER DIRECTION.

FIGURE 10. Crash impact test fixture.

MIL-DTL-27422D

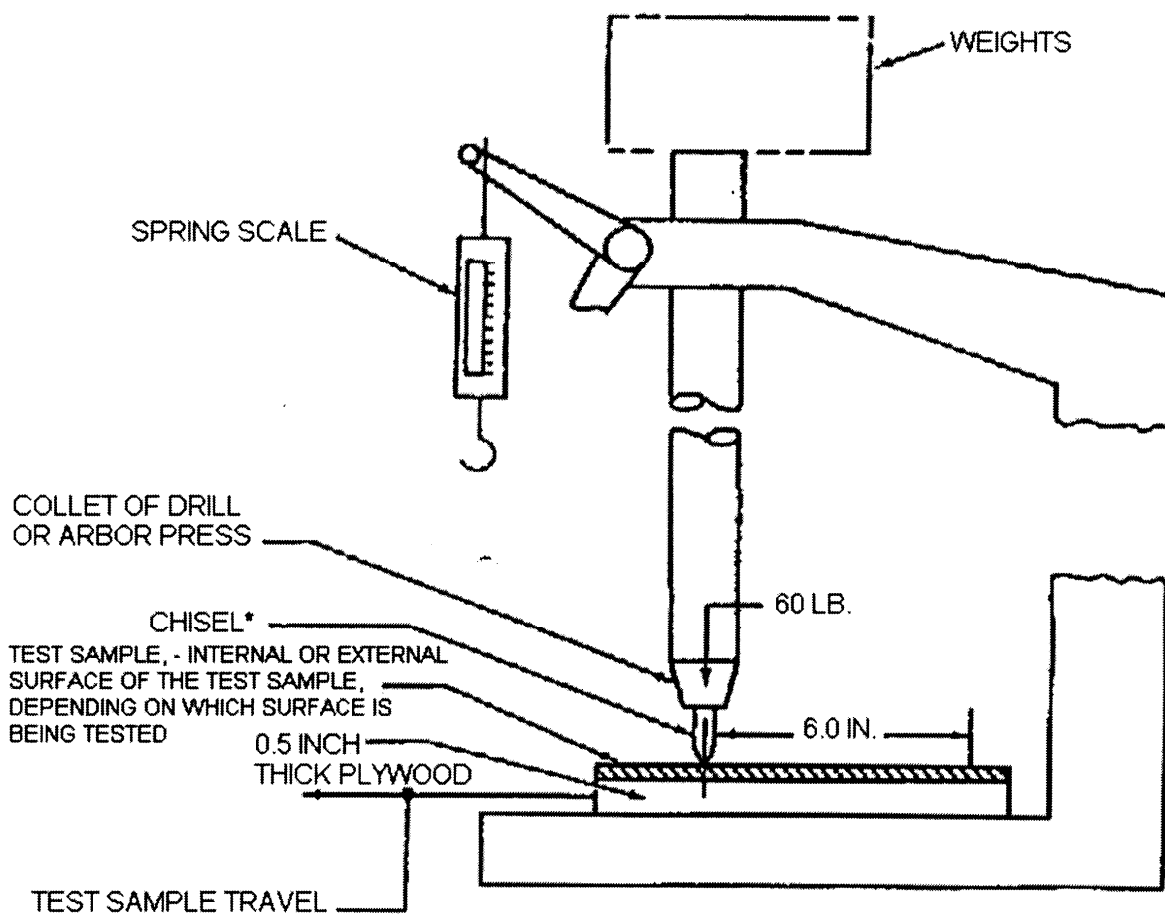

* AS SHOWN IN FIGURE 13

DIMENSIONS ARE IN INCHES.

FIGURE 11. Abrasion test.

MIL-DTL-27422D

IMPACT CHISEL - MATERIAL: STEEL BAR -- 4130 PER SAE-AMS-S-6758.
CONDITION F OR EQUIVALENT

TOLERANCES +/- .010 EXCEPT WHERE SPECIFIED

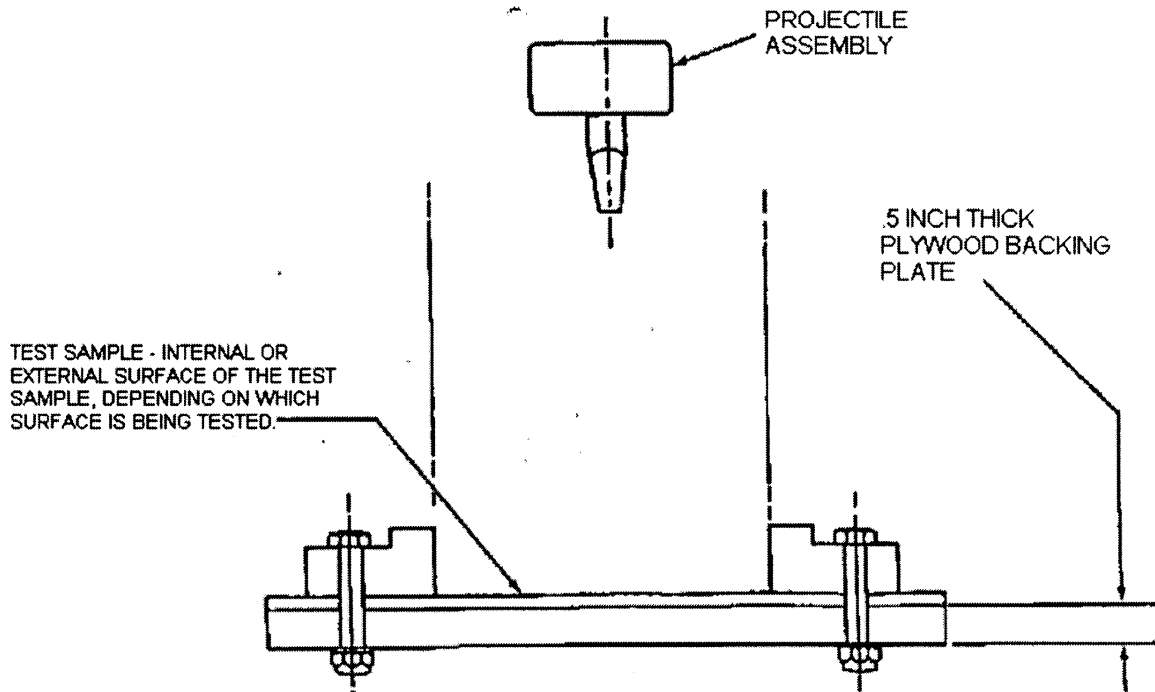
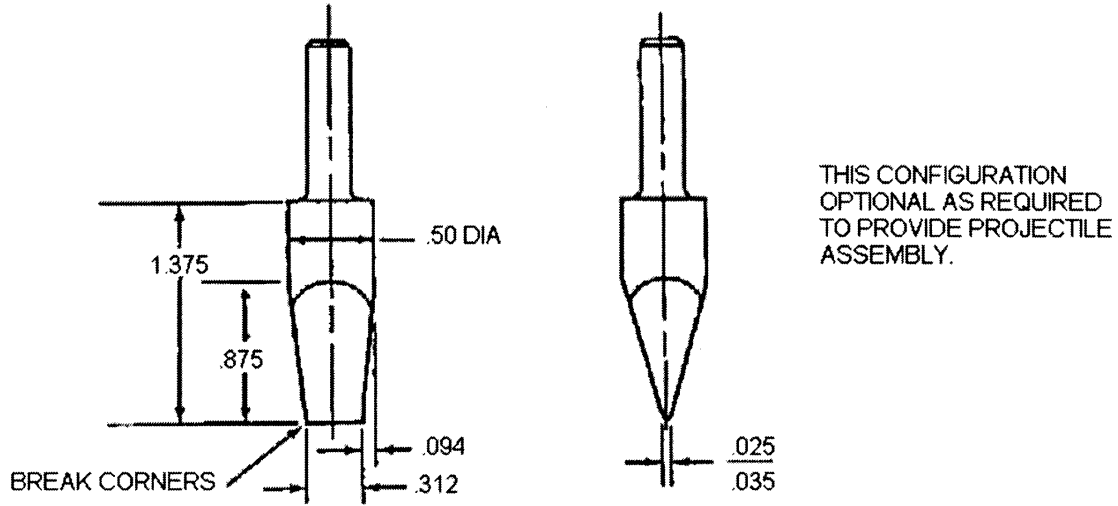

DIMENSIONS ARE IN INCHES.

FIGURE 12. Impact chisel.

MIL-DTL-27422D

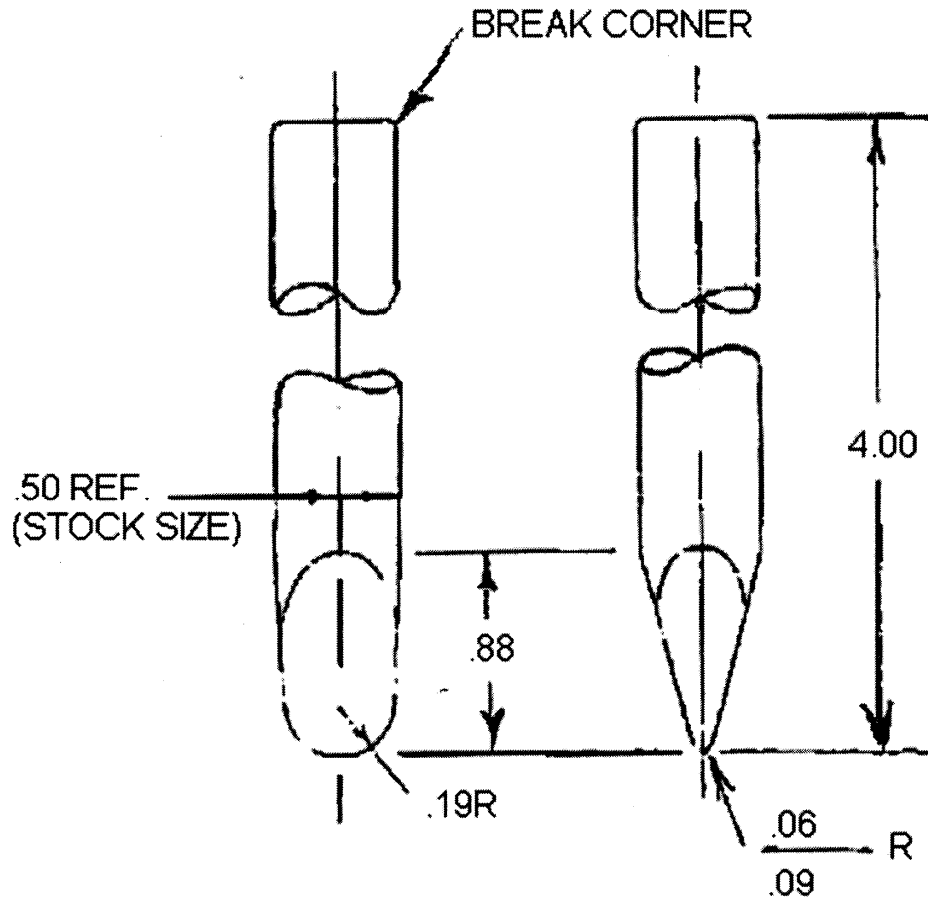

TOLERANCES $\pm .03$ EXCEPT AS NOTED.

MATERIAL: 1/2 INCH DIAMETER STEEL BAR 4130 PER SAE-AMS-S-6758 CONDITION "F" OR EQUIVALENT.

DIMENSIONS ARE IN INCHES.

FIGURE 13. Abrasion chisel.

MIL-DTL-27422D

Custodians:

Army - AV
Navy - AS

Preparing activity:

Army - AV
(Project 1560-2007-001)

NOTE: The activities listed above were interested in this document as of the date of this document. Since organizations and responsibilities can change, you should verify the currency of the information above using the ASSIST Online database at www.assist.daps.dla.mil.