

INCH-POUND

MIL-DTL-25879E  
 18 February 2000  
 SUPERSEDING  
 MIL-PRF-25879D(USAF)  
 11 October 1996

## DETAIL SPECIFICATION

SWITCH, RADIO FREQUENCY TRANSMISSION LINE,  
 COAXIAL TYPE SA-521A/A

This specification is approved for use by all Departments and Agencies of the Department of Defense.

## 1. SCOPE

1.1 Scope. This specification covers the requirements for one type of radio frequency (R. F.) switch, intended specifically for use in switching coaxial lines between multiple communication and navigation antennas.

## 2. APPLICABLE DOCUMENTS

2.1 Government documents.

2.1.1 Specifications and standards. The following specifications and standards form a part of this document to the extent specified herein. Unless otherwise specified, the issues of these documents are those listed in the issue of the Department of Defense Index of Specifications and Standards (DODISS) and supplement thereto, cited in the solicitation (see 6.2).

## SPECIFICATIONS

## DEPARTMENT OF DEFENSE

- |                 |   |  |
|-----------------|---|--|
| MIL-PRF-39012   | - | Connectors, Coaxial, Radio Frequency, General Specification For.   |
| MIL-PRF-39012/1 | - | Connectors, Plug, Electrical, Coaxial, Radio Frequency (Series N (Cabled), Pin Contact, Class 2).                                      |
| MIL-PRF-39012/2 | - | Connectors, Plugs and Receptacles, Electrical, Coaxial, Radio Frequency, (Series N (Cabled), Flange Mounted, Socket Contact, Class 2). |
| MIL-DTL-32054   | - | Mounting MT-1995/A for Coaxial Type SA-521A/A Radio Frequency Transmission Line Switch.  |

## STANDARDS

## DEPARTMENT OF DEFENSE

- |             |   |  |
|-------------|---|--|
| MIL-STD-202 | - | Test Method Standard Electronic and Electrical Component Parts.                            |
| MIL-STD-461 | - | Requirements for the Control of Electromagnetic Interference Emissions and Susceptibility. |
| MS3456      | - | Connectors, Plug, Electrical, Rear Release, Crimp Contact, AN Type.                        |

(Unless otherwise indicated, copies of federal and military specifications, standards, and handbooks are available from the Defense Automated Printing Service, Building 4D (Customer Service), 700 Robbins Avenue, Philadelphia, PA 19111-5094.)

Beneficial comments (recommendations, additions, deletions) and pertinent data of use in improving this document should be addressed to: Defense Supply Center Columbus, ATTN: DSCC-VAT, P.O. Box 3990, Columbus, OH 43216-5000, by using the Standardization Document Improvement Proposal (DD Form 1426) appearing at the end of this document or by letter.

AMSC N/A

DISTRIBUTION STATEMENT A. Approved for public release; distribution is unlimited.

FSC 5985

MIL-DTL-25879E

2.2 Non-Government publications. The following documents form a part of this document to the extent specified herein. Unless otherwise specified, the issues of the documents which are DoD adopted are those listed in the issue of the DODISS cited in the solicitation. Unless otherwise specified, the issues of documents not listed in the DODISS are the issues of the documents cited in the solicitation (see 6.2).

AMERICAN SOCIETY FOR TESTING AND MATERIALS (ASTM)

ASTM-B108 - Aluminum-Alloy Permanent Mold Castings (DoD adopted).

(Application for copies should be addressed to the American Society for Testing and Materials, 1916 Race Street, Philadelphia, PA 19103.)

AMERICAN NATIONAL STANDARDS INSTITUTE (ANSI)

ANSI-Z540.1 - Laboratories, Calibration, and Measuring and Test Equipment (DoD adopted).

(Application for copies should be addressed to the American National Standards Institute, 11 West 42nd Street, New York, NY 10036.)

2.3 Order of precedence. In the event of a conflict between the text of this document and the references cited herein, the text of this document takes precedence. Nothing in this document, however, supersedes applicable laws and regulations unless a specific exemption has been obtained.

3. REQUIREMENTS

3.1 First article approval. Coaxial switches furnished under this specification shall be a product which meets requirements for first article approval (see 4.4 and 6.3). The switch, SA-521A/A, and mounting, MT-1995/A (see MIL-DTL-32054), shall be first article approved together and at the same time (see figure 1).

3.1.1 Classification. The SA-521A/A switch shall be designed for 70,000 ft. altitude and continuous sea level operation over the temperature range of -54° to +71°C (+95° intermittent operation), with exceptions as specified herein.

3.1.2 Materials. Materials shall be used that will enable the switches to meet the requirements of this specification. Acceptance or approval of any constituent material shall not be construed as a guaranty of the acceptance of the finished product (see 4.2).

3.1.2.1 Dissimilar metals. Unless suitably protected against electrolytic corrosion, dissimilar metals shall not be used in intimate contact with each other. Dissimilar metals are defined as metal specimens that are in contact or otherwise electrically connected to each other in a conductive solution and that generate an electric current.

3.1.2.2 Fungus. Materials used in the construction of switches shall be fungus inert. Fungus inert material is defined as a material which, in all modified states and grades, is not a nutrient to fungi.

3.1.2.3 Finish. If the body of a switch is painted, it shall be painted with a semi-gloss or dull enamel finish. Unless otherwise specified, all aluminum not intended to make electrical contact shall be treated. For guidance on finishes see 6.6.

3.1.3 Maintainability. Provisions shall be made for rapid checkouts of the equipment using standard test equipment only. Mounting provisions shall ensure that a minimal amount of maintenance time and effort is required for removal and replacement, using standard tools only.

MIL-DTL-25879E

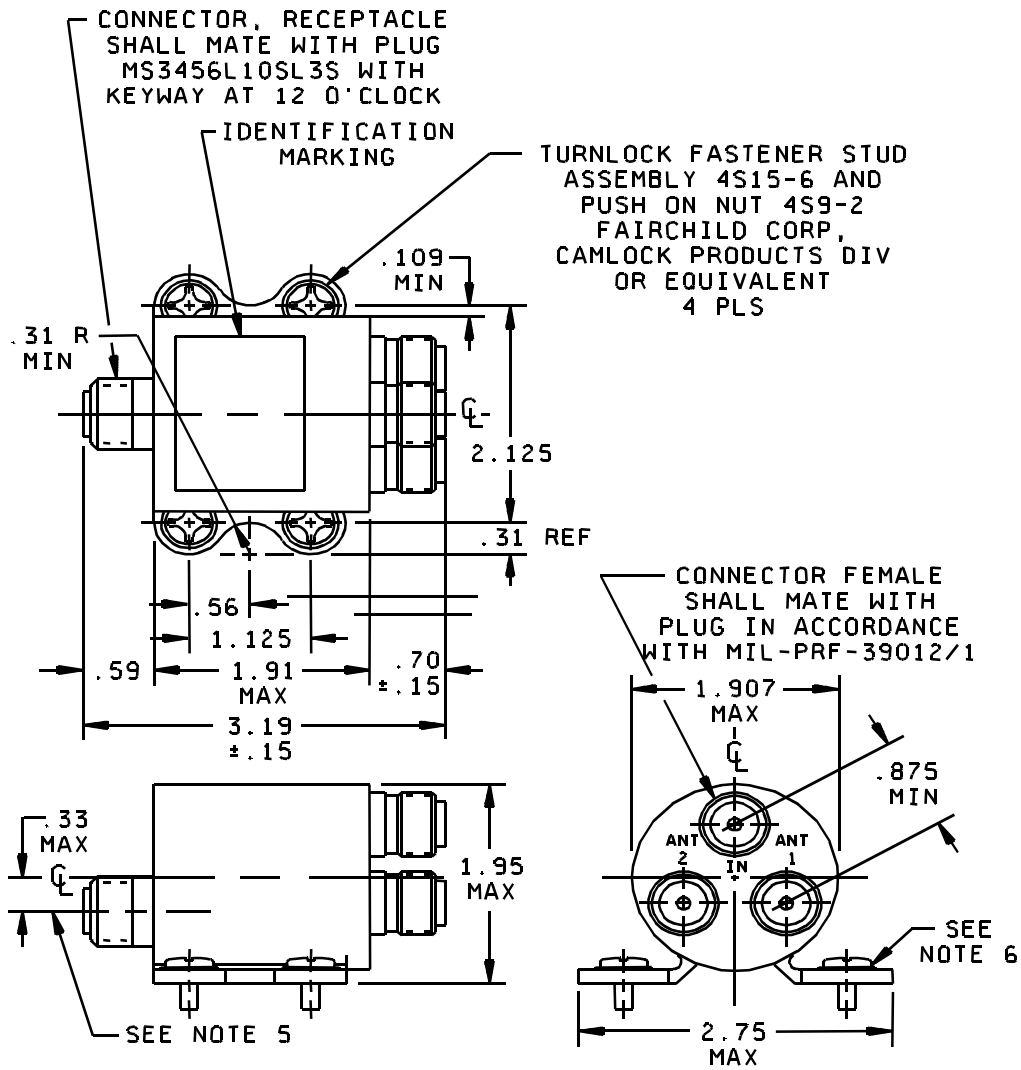
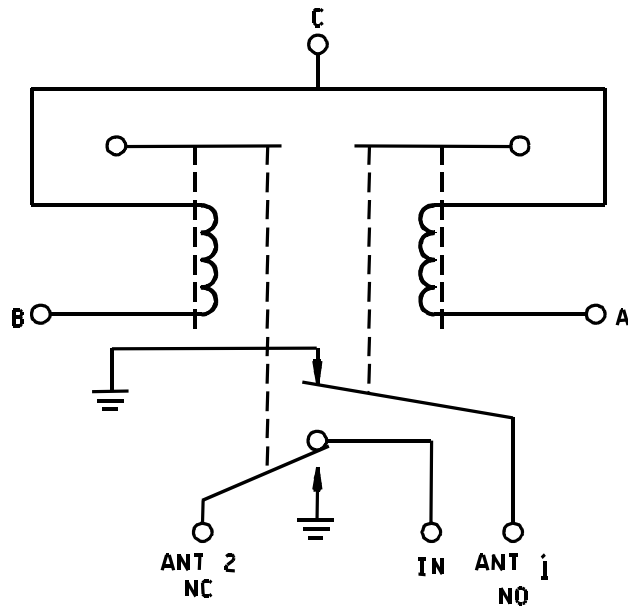

FIGURE 1. Outline and dimensions of switch type SA-521A/A.

MIL-DTL-25879E



SCHEMATIC  
SHOWN IN  
DEENERGIZED CONDITION

Inches	Millimeters	Inches	Millimeters
.125	3.18	1.875	47.62
.33	8.38	1.91	48.51
.56	14.22	1.95	49.53
.72	18.29	2.125	53.98
.885	22.48	2.75	69.85
1.125	28.58	3.19	81.03

## NOTES:

1. Dimensions are in inches.
2. Metric equivalents (to the nearest 0.01 mm) are given for general information only and are based upon 1 inch = 25.4 mm.
3. Unless otherwise specified, tolerances are  $\pm 0.010$  inch (0.25 mm) for three place decimals and  $\pm 0.03$  inch (0.76 mm) for two place decimals.
4. Keyway of power connector to be at 12 o'clock position.
5. The centerline of the power connector shall be no higher than the centerline of the switch body.
6. Positive electrical continuity between the switch unit and the individual fasteners shall be assured.

FIGURE 1. Outline and dimensions of switch type SA-521A/A - Continued.

## MIL-DTL-25879E

3.2 Design and construction. The R.F. transmission switch SA-521A/A shall be designed to operate as a single-pole double-throw coaxial switch. When the switch is deenergized, the internal R. F. connection shall return to a normally closed condition with the common terminal connected to terminal number 2. Separate functions shall be provided to permit both outputs to be connected to the common terminal at once and for both outputs to be disconnected at once when specially energized. The switch shall employ make-before-break contact arrangements for switching from position 1 to position 2, and from position 2 to position 1.

3.2.1 Drawings and procedures. The original design and construction drawings and production procedures as approved by first article testing shall remain available for the inspection by the cognizant government inspector. No changes or waivers shall be allowed without approval of the preparing activity (see 6.3).

3.2.2 General. Any military specification, standard, or handbook referred to in this specification may be replaced by an equivalent commercial standard as determined by the preparing activity (see 6.3).

3.2.3 Frequency. The R.F. switch shall be designed to operate at any frequency up to and including 1.250 GHz.

3.2.4 Nominal impedance. Nominal impedance of the switch shall be 50  $\Omega$ .

3.2.5 Mounting provisions. The R.F. switch shall mate with mounting MT-1995/A (see MIL-DTL-32054). Positive electrical continuity between the switch unit and the individual fasteners shall be assured.

3.2.6 Connectors.

3.2.6.1 Power connector. The power connector shall be sealed, and shall mate with connector MS3456L10SL3S. The pin arrangement shall be as follows:

- a. When pins A and C are connected to a 28 V dc source, the switch shall present a parallel connection of both outputs to the input.
- b. When pins B and C are connected to a 28 V dc source, the switch shall present an open circuit between both outputs and the input.
- c. When pins A and B are parallel and connected with pin C to a 28 V dc source, the switch shall change over from antenna number 2 position to antenna number 1 position.
- d. When the switch is deenergized, the input shall be connected to antenna 2.
- e. Pin C shall be considered to be the common terminal and shall not be grounded internally.

3.2.6.2 R. F. connectors. The R. F. switch shall be equipped with a receptacle connector meeting the mating dimensions of MIL-PRF-39012/2 to mate with "N" series connector (M39012/01-0002 or M39012/01-0005) in accordance with MIL-PRF-39012/1. The input shall be labeled "IN"; the outputs shall be labeled as shown on figure 1.

3.2.6.3 Connector caps. All connectors shall be supplied with push-on caps to prevent connector damage and the entrance of moisture and foreign material during storage.

3.2.7 R. F. contact construction. The R. F. contacts of the switch shall be constructed to provide a wiping action during operation.

3.2.8 Housing. The housing shall be immersion-proof (see 3.4.2 and 4.7.15).

3.2.9 Retention devices. All screws and other hardware shall be adequately equipped with retaining devices to prevent loosening from vibration or shock over the life of the switch.

3.2.10 R. F. interference. R.F. interference control requirements shall be in accordance with MIL-STD-461.

3.2.11 Weight. The weight of the switch shall not exceed 1 pound.

3.3 Performance (electrical).

## MIL-DTL-25879E

3.3.1 Operating voltage. When tested as specified in 4.7.2, the switch shall operate properly within the limits and conditions specified.

3.3.2 Operating current. When tested as specified in 4.7.3, the operating current shall not exceed one ampere.

3.3.3 Switching rate. When tested as specified in 4.7.4, the switch shall operate properly up to 140 operations per minute.

3.3.4 Switching time. When tested as specified in 4.7.5, the switching time shall not exceed 20 ms.

3.3.5 Voltage standing wave ratio (VSWR). When tested as specified in 4.7.6, the VSWR shall not exceed 1.2:1.

3.3.6 Insertion loss. When tested as specified in 4.7.7, the insertion loss shall not exceed 0.20 dB.

3.3.7 Isolation. When tested as specified in 4.7.8, the isolation shall be not less than 40 dB.

3.3.8 Insulation resistance (R. F.). When tested as specified in 4.7.9, the insulation resistance shall be not less than 10 M $\Omega$ .

3.3.9 Dielectric withstanding voltage. When tested as specified in 4.7.10, all current carrying portions of the switch shall successfully withstand the application of 1,000 V rms at 60 Hz.

3.3.10 R. F. power handling capability. When tested as specified in 4.7.11, the switch shall be capable of switching 4.5 kW peak power at 0.1 percent duty cycle (4.5 W average) and carry 100 W average power in a steady-state condition.

3.3.11 Internal R. F. contact resistance. When tested as specified in 4.7.12, the switch contact resistance shall not exceed 0.025  $\Omega$  at 1 A.

3.3.12 Connector torque. When tested as specified in 4.7.13, the power and R. F. connectors shall withstand 45 foot-pounds of torque.

#### 3.4 Performance (environmental).

3.4.1 Thermal shock. When tested as specified in 4.7.14, the switch shall meet the original parameters for switching time, VSWR, and dielectric withstanding voltage.

3.4.2 Immersion. When tested as specified in 4.7.15, the switch shall show no evidence of leaking.

3.4.3 Shock. When tested as specified in 4.7.16, the switch shall meet the original parameters for switching time and VSWR.

3.4.4 Random vibration. When tested as specified in 4.7.17, continuity of the R. F. contacts shall remain stable in each of all possible positions. After completion of the vibration test, the switching time and VSWR shall meet the original parameters.

3.4.5 Humidity. When tested as specified in 4.7.18, the switch shall show no visible evidence of deterioration and the dielectric withstanding voltage test shall meet the original parameters.

3.4.6 Salt spray. When tested as specified in 4.7.19, the switch shall show no evidence of external deterioration and the VSWR, switching time, and dielectric withstanding voltage test values shall meet the original parameters.

3.5 Reliability. When tested as specified in 4.7.20, the switch shall provide a minimum acceptance mean time between failures (MTBF) of 1,000 hours.

3.6 Marking (see 3.1). Switches shall be marked in a legible and permanent manner with the following information.

- a. The R. F. connections shall be identified as shown on figure 1.
- b. Minimum marking shall include the following:
  - (1) Name: Switch, R. F. transmission line.
    - (a) Part or Identifying Number (PIN): Type SA-521A/A.

## MIL-DTL-25879E

- (b) Voltage: 28 V dc maximum.
- (c) Serial number: Taken from a block assigned by Defense Supply Center Columbus, Code VQE.
- (d) Contract number: As assigned by acquiring agency.
- (e) Manufacturer CAGE code.

The marking shall remain legible after completing all environmental tests.

3.7 Workmanship. Switches shall be manufactured and processed in a careful and workmanlike manner, in accordance with good design and sound engineering practice, and to the requirements of this specification. For guidance on workmanship see 6.7.

#### 4. VERIFICATION

4.1 Classification of inspections. The inspections specified herein are classified as follows:

- a. Materials inspection (see 4.2).
- b. First article inspection (see 4.4).
- c. Conformance inspection (see 4.5).

4.2 Materials inspection. Materials inspection shall consist of certification supported by verifying data (see 6.3) that the materials listed in table I, used in fabricating the switches, are in accordance with the applicable specifications or requirements prior to such fabrication.

TABLE I. Materials inspection.

Material	Requirement paragraph
Dissimilar metals -----	3.1.2.1
Fungus -----	3.1.2.2
Finishes -----	3.1.2.3
Connectors -----	3.2.6

4.3 Inspection conditions. Unless otherwise specified herein, all inspections shall be performed in accordance with the test conditions specified in the "GENERAL REQUIREMENTS" of MIL-STD-202.

4.4 First article inspection (see 3.1). First article inspection shall be performed at a laboratory acceptable to the Government (see 6.3) on sample units produced with equipment and procedures normally used in production.

4.4.1 Sample size. Twelve switches shall be subjected to first article inspection tests specified herein.

4.4.2 Inspection routine. The sample shall be subjected to the inspections specified in table II, in the order shown. All sample units shall be subjected to the inspections of group I. The sample shall then be divided into two groups of 6 units each. The sample units shall then be subjected only to the inspections indicated for their particular group.

## MIL-DTL-25879E

TABLE II. First article inspection.

Examination or test	Requirement paragraph	Test paragraph
<u>Group I (all samples)</u>		
Visual and mechanical	3.2	4.7.1
Marking	3.6	4.7.1
Workmanship	3.7	4.7.1
Weight	3.2.11	4.7.1
Operating voltage	3.3.1	4.7.2
Operating current	3.3.2	4.7.3
Switching rate	3.3.3	4.7.4
Switching time	3.3.4	4.7.5
VSWR	3.3.5	4.7.6
Insertion loss	3.3.6	4.7.7
Isolation	3.3.7	4.7.8
R. F. power handling capability	3.3.10	4.7.11
Internal R. F. contact resistance	3.3.11	4.7.12
Thermal shock	3.4.1	4.7.14
Humidity	3.4.5	4.7.18
Salt spray	3.4.6	4.7.19
<u>Group II (6 samples)</u>		
Shock	3.4.3	4.7.16
Random vibration	3.4.4	4.7.17
Connector torque	3.3.12	4.7.13
Immersion	3.4.2	4.7.15
Insulation resistance	3.3.8	4.7.9
Dielectric withstanding voltage	3.3.9	4.7.10
<u>Group III (6 samples)</u>		
Reliability	3.5	4.7.20

4.4.3 Failures. No failures shall be allowed for first article inspection; a failure shall be anything that does not meet the requirements of the specification.

#### 4.5 Conformance inspection.

4.5.1 Inspection of product for delivery. Inspection of product for delivery shall consist of group A.

4.5.1.1 Inspection lot. An inspection lot shall consist of all switches produced under essentially the same conditions, and offered for inspection at one time. The lot size shall not exceed 200.

4.5.1.2 Group A inspection. Group A inspection shall consist of the examinations and tests specified in table III, in the order shown.

4.5.1.2.1 Inspection plans. The specification utilizes an accept on zero defect ( $c = 0$ ) sampling plan. Sampling shall be in accordance with table III. Sample categories indicated in table III shall be cross referenced to the appropriate sample sizes in table IV.



## MIL-DTL-25879E

TABLE III. Group A inspection.

Examination or test	Requirement paragraph	Test paragraph	Sample category
<u>Subgroup I</u>			
Visual and mechanical	3.2	4.7.1	A
Marking	3.6	4.7.1	B
Workmanship	3.7	4.7.1	B
Weight	3.2.11	4.7.1	A
Operating voltage	3.3.1	4.7.2	B
Switching rate	3.3.3	4.7.4	B
Switching time	3.3.4	4.7.5	B
VSWR	3.3.5	4.7.6	B
Internal R. F. contact resistance	3.3.11	4.7.12	A
Dielectric withstanding voltage	3.3.9	4.7.10	A
Insulation resistance	3.3.8	4.7.9	A
<u>Subgroup II</u>			
Operating current	3.3.2	4.7.3	<u>1/</u>
Reliability	3.5	4.7.20	<u>1/</u>

1/ Monthly sample size shall be a minimum of 3 per lot.

TABLE IV. Sampling plans.

Sample category	Sample size		
	A	B	C
<u>Lot size</u>			
2 to 8	all	all	all
9 to 15	all	all	all
16 to 25	all	16	all
26 to 50	all	20	26
51 to 90	all	20	32
91 to 150	all	20	32
151 to 200	all	20	32

4.5.1.3 Tightened inspection. If a lot fails, sample size C per table IV shall be used in place of sample size B for group A inspection until at least 3 consecutive lots have passed.

4.5.1.4 Rejected lots. If an inspection lot is rejected, the supplier may rework it to correct the defects, or screen out the defective units, and resubmit for reinspection. Resubmitted lots shall be inspected using tightened inspection. Such lots shall be separate from new lots, and shall be clearly identified as reinspected lots.

4.5.1.5 Disposition of sample units. Sample units which have been subjected to group A, subgroup II inspection shall not be delivered on the contract or purchase order.

4.5.2 Group B inspection. Group B inspection shall consist of the tests specified in table V, in the order shown. Group B inspection shall be made on sample units which have passed group A subgroup I inspection. Except where the results of these inspections show noncompliance with the applicable requirements, delivery of products which have passed group A shall not be delayed pending the results of these verification inspections.

## MIL-DTL-25879E

TABLE V. Group B inspection. 1/

Test	Requirement paragraph	Test paragraph	Number of sample units to be inspected
R. F. power handling capability -----	3.3.10	4.7.11	6
Thermal shock -----	3.4.1	4.7.14	
Random vibration -----	3.4.4	4.7.17	
Shock -----	3.4.3	4.7.16	
Connector torque -----	3.3.12	4.7.13	
Immersion -----	3.4.2	4.7.15	

1/ Inspection for each test shall be performed on a sample of 6 units. No failures shall be allowed. A sample unit having one or more defects shall be considered as a single failure.

4.5.2.1 Post tests. The manufacturer, at his option, need not perform the post tests described after each environmental performance test as referenced in 3.4 until after all the environmental performance tests are completed. The requirements for each post test referenced must be met at this time.

4.5.2.2 Failures. If there are any failures, the sample shall be considered to have failed.

4.5.2.3 Disposition of sample units. Sample units which have been subjected to group B inspection shall not be delivered on the contract or purchase order.

4.6 Test equipment and inspection facilities. Test and measuring equipment and inspection facilities of sufficient accuracy, quality, and quantity to permit performance of the required inspection shall be established and maintained by the supplier. The establishment and maintenance of a calibrated system to control the accuracy of the measuring and test equipment shall be in accordance with ANSI-Z540.1. The instruments used in making the first article approval electrical tests shall have been compared with the secondary standards within thirty days of the beginning of the first article approval tests.

4.7 Methods of examination and test.

4.7.1 Visual and mechanical examination (see 3.1.2, 3.1.2.1, 3.1.2.3, 3.2, 3.2.5, 3.2.9, 3.2.11, 3.6, and 3.7). Switches shall be examined to verify that the materials, size, mounting, weight, design, construction, finish, marking, and workmanship are in accordance with the applicable requirements.

4.7.2 Operating voltage test (see 3.3.1). The voltage necessary for positive operation of the switch shall be measured using a calibrated voltmeter. The pull-in voltage shall be considered to be the voltage required to operate the switch in 0.1 second or less, after closing the primary power circuit. Satisfactory operation shall be accomplished under the following conditions:

<u>Voltage limit</u>	<u>Temperature</u>
24 V to 29 V	-55°C
19 V to 29 V	+20°C

4.7.3 Operating current (see 3.3.2). The operating current at +20°C (±5°C) shall not exceed .5 A dc at 25 V for one solenoid and 1 A dc for both solenoids simultaneously. The switch shall be designed to permit the negative side of the power input source to be grounded externally.

4.7.4 Switching rate (see 3.3.3). The switch shall provide the performance specified herein when switching at rates up to 140 times per minute.

## MIL-DTL-25879E

4.7.5 Switching time (see 3.3.4). Switching time shall be measured using an oscilloscope or other acceptable means approved by the preparing activity (see 6.3). The trace shall show contact switching at operate and release and appropriate timing markers. Rated voltage shall be applied to the coil. High level contacts shall be loaded at 100 mA at 28 Vdc. Contact bounce shall be measured at 100 mA at 28 Vdc. A contact bounce shall be considered any occurrence equal to or greater than 90 percent of the open circuit voltage with a pulse width of 10  $\mu$ s or greater. Switching time shall be the operate and release time inclusive of contact bounce. The circuit shown in figure 2, or equivalent, shall be used. The test shall be run at +20°C ( $\pm$ 5°C) and at -55°C ( $\pm$ 5°C). The switching times at +20°C ( $\pm$ 5°C) for the following positions shall not exceed 20 ms.

- a. Position 1 to position 2.
- b. Position 2 to position 1.
- c. Either position to both ON.
- d. Either position to both OFF.

For each of the operations specified above, at -55°C ( $\pm$ 5°C), the switching time shall not exceed 25 ms.

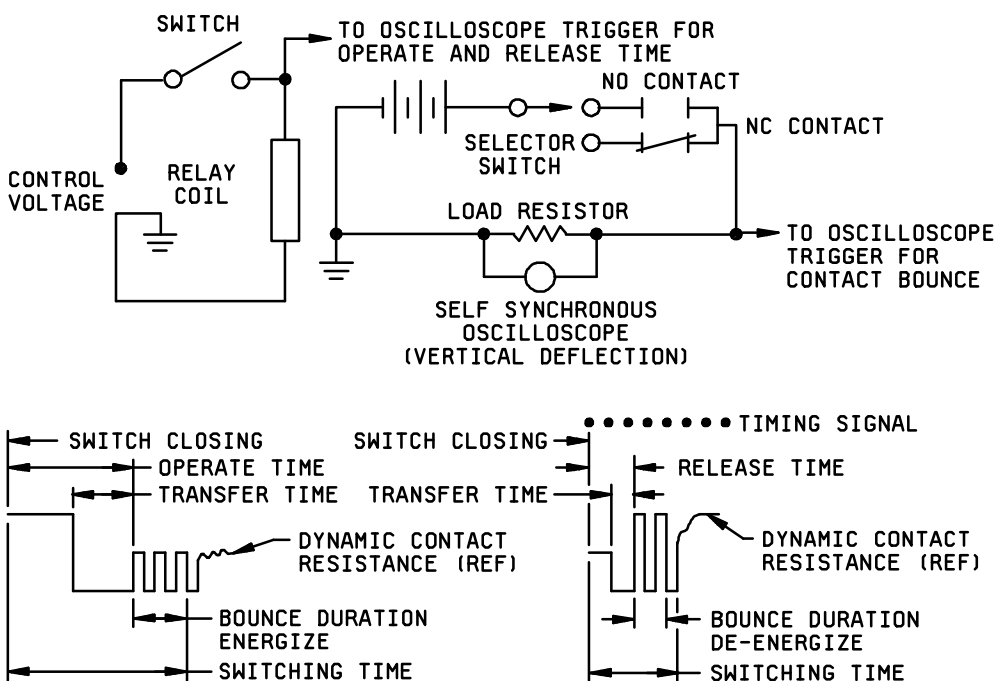

NOTE: The horizontal scan rate of the oscilloscope shall show the required pertinent data.

FIGURE 2. Typical circuit for switching time with typical traces.

## MIL-DTL-25879E

4.7.6 VSWR (see 3.3.5). The VSWR increase caused by the insertion of the R. F. switch in a 50  $\Omega$  transmission line and terminated in a 50  $\Omega$  resistive load shall not exceed 1.2:1. Conventional slotted lines using tuned bolometer detecting attachment or sweep frequency techniques may be used. The use of crystal detectors is prohibited. The loads used for termination shall be measured separately at the test frequencies. As a minimum requirement, tests shall be made at .250, .325, .400, .950, 1.025, 1.100, 1.175, and 1.250 GHz and the measurements shall be recorded. The above shall apply when the switch is positioned so that the input connects only to antenna 1 and again when the input connects only to antenna 2.

4.7.7 Insertion loss (see 3.3.6). The attenuation caused by insertion of the R. F. switch in a 50  $\Omega$  transmission line shall not exceed 0.2 dB at 1.250 GHz when the line is terminated in a 50  $\Omega$  resistive load and the switch circuit is completed. The measurement shall be made using conventional measurement techniques. Care shall be exercised in measurement since small errors can result in large deviations in final results. The average of three test runs shall be used as a final result.

4.7.8 Isolation (see 3.3.7). The switch shall be so inserted between the signal generator and the slotted line that they are connected by the switch and shall terminate in a resistive load equal to the characteristic impedance. The termination resistor shall be adjusted for minimum standing wave ratio. The output of the signal generator shall be adjusted to give a large reading on the decibel meter of the tuned amplifier. This reading shall be recorded. Without changing the position of the switch contacts, the signal generator shall be connected to the other unused connector of the switch. An additional terminating resistor equivalent to the characteristic impedance shall be connected to the connector from which the signal generator was previously disconnected. Without disturbing any of the adjustments made previously, a reading of the decibel meter shall be recorded. This reading should be much smaller than the one recorded previously. The difference between these two readings is the attenuation between used and unused channels of the switch. This measurement should be repeated for all other combinations of the connectors in the switch. The attenuation, measured to the opposite terminal in either an energized or a deenergized condition, shall be at least 40 dB. The signal source shall be a signal generator operating at 1.250 GHz and having a 4.5 kW peak power source at a 0.1 percent duty cycle.

4.7.9 Insulation resistance (see 3.3.8). The insulation resistance shall be tested in accordance with method 302 of MIL-STD-202, test condition C. The test voltage shall be applied to the center contact of each R. F. connector in turn (with solenoids in both deenergized and energized positions). The insulation resistance shall be not less than 10 M $\Omega$ .

4.7.10 Dielectric withstanding voltage (see 3.3.9). All current carrying portions of the switch shall be suitably insulated for the intended purpose and shall withstand the application of 1,000 V rms, 60 Hz between switching circuits (not mutually connected), circuits and coils, circuits and enclosure, and coils and enclosure. Each application shall be conducted for one minute. There shall be no evidence of momentary or intermittent arcing or other indication of breakdown, nor shall there be any visible evidence of breakdown.

4.7.11 R. F. power handling capability (see 3.3.10). Both output (antenna) terminals shall be terminated in 50  $\Omega$  resistance loads. In a steady-state condition, the switch shall be capable of handling 100 W average power, at 2 MHz or higher frequency, for a minimum of 30 minutes in each switching position, with no appreciable heating or increase in R. F. contact resistance. In addition, with applied R. F. power of 4.5 kW at 0.1 percent duty cycle at 1.250 GHz, the switch shall be operated at 140 operations per minute for at least 50 hours. The contact resistance shall not exceed 0.025  $\Omega$  at 1 ampere at the end of the test (50 hours cumulative operation).

4.7.12 Internal R. F. contact resistance (see 3.3.11). Both output (antenna) terminals shall be terminated in 50  $\Omega$  resistive loads. Apply 4.5 W average power at 240 MHz to the input terminal. The switch shall be operated at a rate of 140 operations per minute, in such a sequence that the input never sees an open circuit, for a cumulative period of 10 hours. Acceptance shall be based on zero failures. Test limits are shown below:

	<u>Cumulative operating time (hours)</u>	<u>R. F. contact resistance Ohms (maximum)</u>
First article testing	10	.025 $\Omega$ at 1 A
Acceptance testing	3 or 10	1/

1/ If after 3 hours of testing, the contact resistance is less than .010  $\Omega$  (at 1 A) for less than 10 percent of the lot, the manufacturer may, at his option, terminate the test. However, if 10 percent or more of the lot fails to meet the .010  $\Omega$  maximum limit at the end of 3 hours of testing, the testing shall be continued for the 10 hour duration. If the manufacturer accepts the option, units having contact resistance of .010  $\Omega$  or greater will be either rejected or tested for the 10 hour duration and shall meet the .025  $\Omega$  limit to be accepted.

## MIL-DTL-25879E

4.7.13 Connector torque (see 3.3.12). Each connector shall be subjected to 45 foot-pounds of torque, the procedure of which shall be prepared by the contractor and approved by the design activity (see 6.3). The switch shall pass the immersion test after application of the torque test to each of the connectors.

4.7.14 Thermal shock (see 3.4.1). The switch shall be tested in accordance with method 107 of MIL-STD-202, test condition A, except the minimum temperature shall be -40°C. At the conclusion of the test, the switch shall be removed from the test chamber; returned to standard temperatures; and within a period of 1 hour, operated and tested. Switching time shall meet the original requirements.

4.7.15 Immersion (see 3.4.2). The switch shall be tested in accordance with method 104 of MIL-STD-202, test condition B. The insulation resistance and dielectric withstanding voltage test measurements shall meet the original requirements.

4.7.16 Shock (see 3.4.3). The switch shall be tested in accordance with method 213 of MIL-STD-202, test condition J. The test pulse duration shall be 11 ms. After completion of the test, the VSWR and switching time shall meet the original requirements. There shall be no visible evidence of loosening of parts.

4.7.17 Random vibration (see 3.4.4). The switch shall be tested in accordance with method 214 of MIL-STD-202, test condition I, letter A. The test duration shall be specified as 1.5 hours. The switch contact continuity shall be monitored in each position and shall show no evidence of discontinuity during the test.

4.7.18 Humidity (see 3.4.5). The switch shall be tested in accordance with method 103 of MIL-STD-202, test condition A. After completion of the test, visual inspection shall show no signs of visible deterioration. The dielectric withstanding voltage and insulation resistance test values shall meet the original parameters.

4.7.19 Salt spray (see 3.4.6). The switch shall be tested in accordance with method 101 of MIL-STD-202, test condition A. After completion of the test, the dielectric withstanding voltage, insulation resistance, and switching time shall meet the original parameters.

4.7.20 Reliability (see 3.5). Reliability testing shall be in accordance the manufacturers reliability assurance program, with the following additions and exceptions:

- a. Temperature range: The temperature range shall be -54°C to +85°C.
- b. On-off cycling: On-off cycling shall be 1 hour at -54°C with no electrical operation and 3 hours at +85°C with continual electrical cycling.
- c. Electrical cycling: During the operating period, the switch shall be operated at least 140 times per minute. The contact resistance shall be measured at regular intervals for approximately 100,000 cycles of operation.

## 5. PACKAGING

5.1 Packaging. For acquisition purposes, the packaging requirements shall be as specified in the contract or order (see 6.2). When actual packaging of material is to be performed by DoD personnel, these personnel need to contact the responsible packaging activity to ascertain requisite packaging requirements. Packaging requirements are maintained by the Inventory Control Point's packaging activity within the Military Department or Defense Agency, or within the Military Department's System Command. Packaging data retrieval is available from the managing Military Department's or Defense Agency's automated packaging files, CD-ROM products, or by contacting the responsible packaging activity.

## 6. NOTES

(This section contains information of a general or explanatory nature that may be helpful, but is not mandatory.)

6.1 Intended use. The SA-521A/A switch covered by this specification is intended for use in coupling two antennas to an equipment.

## MIL-DTL-25879E

6.2 Acquisition requirements. Acquisition documents should specify the following:

- a. Title, number, and date of the specification.
- b. Issue of DODISS to be cited in the solicitation, and if required, the specific issue of individual documents referenced (see 2.1.1 and 2.2).
- c. Packaging requirements and levels of preservation: packaging and packing required (see 5.1).
- d. Part number: The switch should normally be ordered without the mounting. If the mounting is required, it should be ordered separately.

6.3 First article approval. The activity responsible for the first article approval of products is Defense Supply Center Columbus, Code VQE, P.O. Box 3990, Columbus, OH 43216-5000, and information pertaining to first article approval of products may be obtained from this activity.

6.4 Substitution data. The switch covered by this specification is substitutable for the following items.

<u>Manufacturer's code</u>	<u>Manufacturer's type or PIN</u>
74868	300 - 10099
26512	GS839L2
82152	50010
72152	13-50-04010
72152	CS-319A, B, D
81349	SA-521A

6.5 Subject term (key word) listing.

Antenna	Dissimilar metals	VSWR
Communication	Finish	
Connector torque	Immersion	
Coupling	Navigation	

6.6 Finish.

6.6.1 Painted finish. Based on past experience, painted finish in accordance with MIL-F-14072, type II, has been used successfully to meet the requirements of this specification.

6.6.2 Chemical conversion coating. Based on past experience, treatment of aluminum in accordance with MIL-C-5541, class 3, has been used successfully to meet the requirements of this specification.

6.7 Workmanship.

6.7.1 Cleaning. After fabrication, parts and assembled equipment should be cleaned of smudges; loose, spattered, or excess solder; weld metal; metal chips and mold release agents; or any other foreign material which might detract from the intended operation, function, or appearance of the switch.

6.7.2 Threaded parts or devices. Screws, nuts and bolts should show no evidence of cross threading, mutilation, or detrimental or hazardous burrs, and should be firmly secured.

6.7.3 Wiring. Wires and cables should be positioned or protected to avoid contact with rough or irregular surfaces and sharp edges and to avoid damage to conductors or adjacent parts.

6.7.4 Shielding. Shielding on wires and cables should be secured in a manner that will prevent it from contacting or shorting exposed current-carrying parts. The ends of the shielding or braid should be secured to prevent fraying.

6.7.5 Containment. The harness and cable form containment means should be neat in appearance, uniformly applied, and positioned to retain critical form factors and breakout locations. The containment means (lacing, ties, tiedown straps, etc.) should not cause the wire or cable insulation to deform so that performance characteristics are adversely affected.

MIL-DTL-25879E

6.7.6 Insulation. There should be no evidence of burns, abrading, or pinch marks in the insulation that could cause short circuits or leakage.

6.7.7 Clearance. The clearance between wires or cables and heat generating parts should be sufficient to minimize deterioration of the wires or cables.

6.8 Changes from previous issue. Marginal notations are not used in this revision to identify changes with respect to the previous issue due to the extensiveness of the changes.

Custodians:  
Air Force - 11  
DLA - CC

Preparing activity:  
DLA - CC

Review activities:  
Air Force - 99

(Project 5985-F647)

<b>STANDARDIZATION DOCUMENT IMPROVEMENT PROPOSAL</b>		
<b><u>INSTRUCTIONS</u></b>		
<p>1. The preparing activity must complete blocks 1, 2, 3, and 8. In block 1, both the document number and revision letter should be given.</p> <p>2. The submitter of this form must complete blocks 4, 5, 6, and 7.</p> <p>3. The preparing activity must provide a reply within 30 days from receipt of the form.</p> <p>NOTE: This form may not be used to request copies of documents, nor to request waivers, or clarification of requirements on current contracts. Comments submitted on this form do not constitute or imply authorization to waive any portion of the referenced document(s) or to amend contractual requirements.</p>		
<b>I RECOMMEND A CHANGE:</b>	<b>1. DOCUMENT NUMBER</b> MIL-DTL-25879E	<b>2. DOCUMENT DATE</b> 18 February 2000
<b>3. DOCUMENT TITLE</b> SWITCH, RADIO FREQUENCY TRANSMISSION LINE, COAXIAL TYPE SA-521A/A		
<b>4. NATURE OF CHANGE</b> <i>(Identify paragraph number and include proposed rewrite, if possible. Attach extra sheets as needed.)</i>		
<b>5. REASON FOR RECOMMENDATION</b>		
<b>6. SUBMITTER</b>		
a. NAME (Last, First, Middle initial)	b. ORGANIZATION	
c. ADDRESS (Include Zip Code)	d. TELEPHONE (Include Area Code) Commercial DSN FAX EMAIL	7. DATE SUBMITTED
<b>8. PREPARING ACTIVITY</b>		
a. Point of Contact ATTN: DSCC-VAT	b. TELEPHONE Commercial      DSN      FAX      EMAIL 614-692-0506    850-0506    614-692-6941    david_ars@dsccl.dla.mil	
c. ADDRESS Defense Supply Center Columbus P.O. Box 3990 Columbus, OH 43216-5000	<b>IF YOU DO NOT RECEIVE A REPLY WITHIN 45 DAYS, CONTACT:</b> Defense Standardization Program Office (DLSC -LM) 8725 John J. Kingman Road, Suite 2533 Fort Belvoir, Virginia 22060-6221 Telephone (703) 767-6888    DSN 427-6888	